

# Service Manual

**CIRCUIT DESCRIPTIONS  
REPAIR & ADJUSTMENTS**



**ORDER NO.  
ART-698-0**

**STEREO TURNTABLE**

# PL-X50

**MODEL PL-X50 COMES IN FIVE VERSIONS DISTINGUISHED AS FOLLOWS:**

Type	Voltage	Remarks
HE	220V and 240V (Switchable)	Europe model
HB	220V and 240V (Switchable)	U.K. model
S	110V, 120V, 220V, 240V (Switchable)	General export model
S/G	110V, 120V, 220V, 240V (Switchable)	U.S. military model
KU	120V only	U.S.A. model

- This is the service manual for model PL-X50/HE, HB. For servicing of the other types, please refer to the additional service manual.
- Ce manuel d'instruction se réfère au mode de réglage, en français.
- Este manual de servicio trata del método de ajuste escrito en español.

# CONTENTS

1. SPECIFICATIONS . . . . .	2	8. ELECTRICAL PARTS LIST . . . . .	37
2. FRONT PANEL FACILITIES . . . . .	3	9. P.C. BOARDS CONNECTION DIAGRAM . . . . .	39
3. BLOCK DIAGRAM . . . . .	4	10. SCHEMATIC DIAGRAM . . . . .	41
4. CIRCUIT DESCRIPTIONS . . . . .	5	11. EXPLODED VIEWS . . . . .	43
5. MAJOR COMPONENT ASSEMBLY/ DISASSEMBLY . . . . .	17	12. ADJUSTMENTS . . . . .	49
6. OPERATIONAL DESCRIPTION . . . . .	22	RÉGLAGE . . . . .	51
7. TROUBLESHOOTING . . . . .	29	AJUSTE . . . . .	53
		13. PACKING . . . . .	55

## 1. SPECIFICATIONS

### Motor and Turntable

Drive System . . . . . Belt-drive  
 Motor . . . . . DC servo motor  
 Speeds . . . . . 33-1/3 and 45rpm  
 Wow and Flutter . . . . . Less than 0.045%(WRMS)  
 Signal-to-Noise Ratio . . . . . More than 70dB (DIN-B)  
 (with Pioneer cartridge model PC-3MC)

### Tonearm

Type . . . . . Integrated straight pipe arm

### PC-3MC Specifications

Type . . . . . Moving coil type  
 Stylus . . . . . 0.5 mil diamond (PN-3MC)  
 Output Voltage . . . . . 2.5mV  
 (1kHz, 50mm/s Peak velocity, LAT)  
 Tracking Force . . . . . 1.7g to 2.3g (proper 2g)  
 Frequency Response . . . . . 10 to 32,000Hz  
 Recommended Load . . . . . 50kΩ  
 Weight . . . . . 3.1g

### Subroutines

Fully automatic operation with separate tonearm motor  
 Automatic record size selector (17cm, 30cm)  
 Cueing device  
 Built-in anti-skating mechanism

### Miscellaneous

Power Requirements . . . . . AC 220/240V~(switchable) 50, 60Hz  
 Power Consumption . . . . . 9W  
 HB model . . . . .  
 Dimensions . . . . . 320(W) x 98(H) x 210(D)mm  
 12-5/8(W) x 3-7/8(H) x 8-1/4(D)in  
 Weight . . . . . 5.5kg/12lb 2oz

### Accessories

EP Adaptor . . . . . 1  
 Output cable . . . . . 1  
 Operating instructions . . . . . 1

*NOTE:*  
 Specifications and design subject to possible modification without notice, due to improvements.

## 2. FRONT PANEL FACILITIES

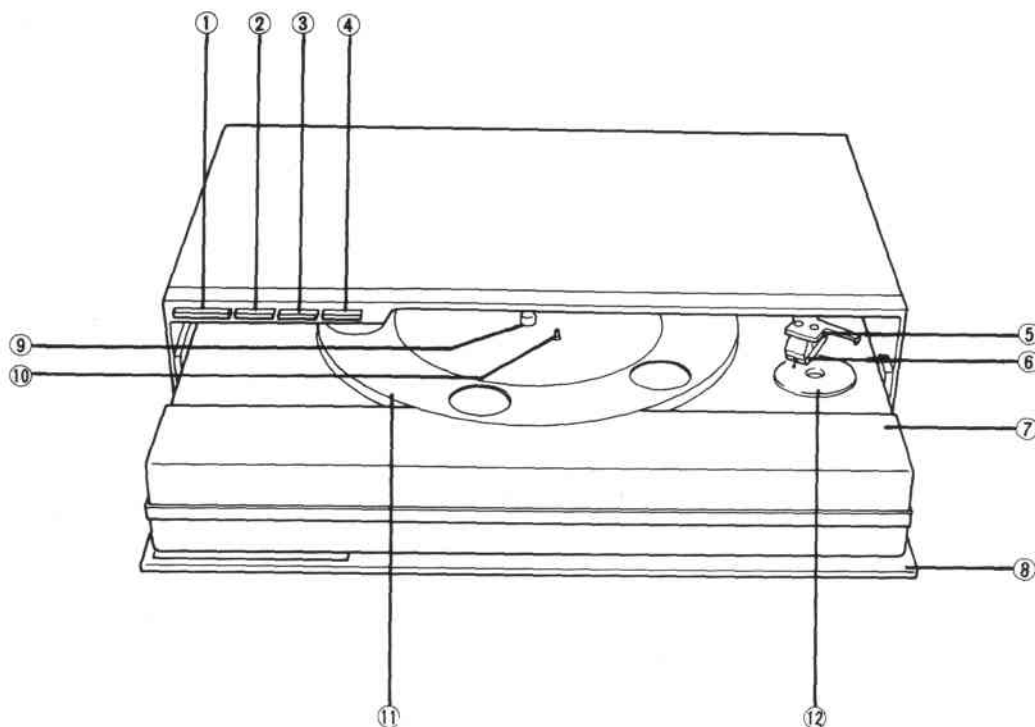

**NOTE:**

The headshell ⑤ and cartridge ⑥ have been drawn so that they are visible for the purpose of explanation only. They can not be seen as shown above during normal operations.

① **PLAYBACK START/STOP SWITCH (PLAY/STOP)**

This switch is depressed to start or stop playback.

② **ARM ELEVATION SWITCH (ARM)**

This switch is used to start playback in the middle of a record or to temporarily stop playback in the middle of a record

Switch depressed [  (up) ] – raises tonearm

Switch released [  (down) ] – lowers tonearm

③ **REPEAT PLAYBACK SWITCH (REPEAT OFF/ON)**

Depressing this switch will cause the turntable to play the record repeatedly.

④ **SPEED SELECTOR SWITCH (SPEED)**

This switch is used to select turntable speed.

Switch depressed (  ) – 45 rpm

Switch released (  ) – 33 1/3 rpm

⑤ **HEADSHELL**

⑥ **CARTRIDGE (PC-3MC)**

⑦ **TURNTABLE**

⑧ **CABINET DOOR**

⑨ **CENTER SHAFT**

⑩ **RECORD SENSING PIN**

This sensor functions to detect whether a record is placed on the platter or not. This turntable will not operate unless a record is placed on the platter. If you attempt to start the turntable before placing a record on the platter, the record sensing pin will detect that there is no record and hold the tonearm in place. This prevents the possibility of the stylus being damaged by coming into direct contact with the turntable platter.

⑪ **PLATTER**

⑫ **EP ADAPTOR**

Use the EP adaptor by placing it on the center shaft when playing back an EP record.

**NOTE:**

Use only this EP adaptor with this turntable.

If a different EP adaptor is used, the stylus may come in contact with the EP adaptor and be damaged.

## 4. CIRCUIT DESCRIPTIONS

The circuit description is based on the operation of the system while playing a 30cm record disc at 33 rpm.

### 4.1 LOADING OUT

1. Sliding the door out causes the power switch S10 to turn ON.
2. Pressing the START/STOP button (switch S6) causes the number 13 pin of IC2 to go from L to H, and this causes the number 15 pin to go to H. When the number 15 pin goes to H, the number 3 (number 8) pin of IC3 also goes to H, and the slide base drive motor (mechanism motor) starts rotating in a CW direction (causing the turntable to come out).
3. As the mechanism motor rotates, the slide base travels from its housed position to its out position. When the slide base reaches the record-load position opening attachment switch S2, the number 3 (number 8) pin of IC3 again goes L, stopping the mechanism motor.

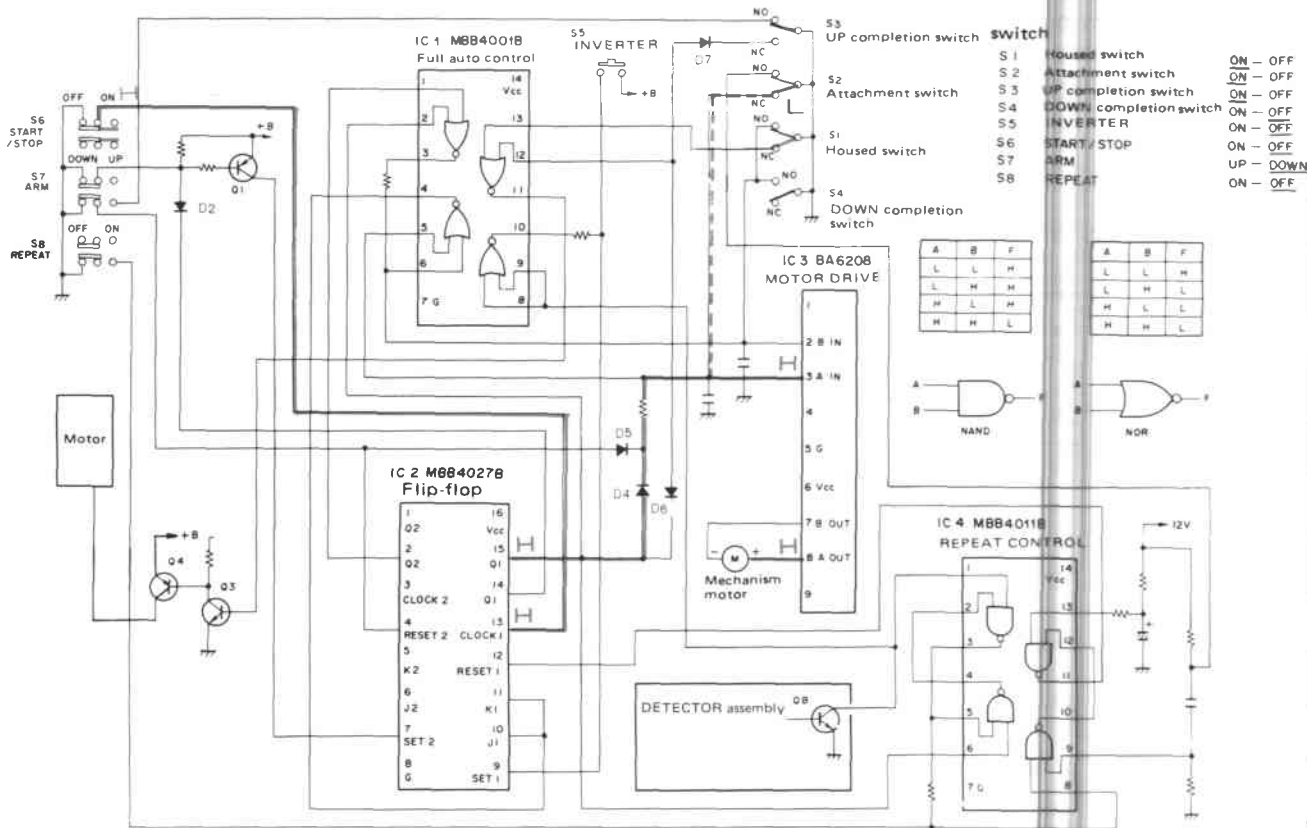

Fig. 4-1 Loading out

### 4.4 AUTO RETURN

1. After record playback is completed and the tonearm stylus moves from the record groove into the lead out groove, the amount of movement of the tonearm causes the collector voltage of transistor Q5 to rise. This causes the base voltage of Q8 to rise, turning the transistor ON (figure 4-4).
2. When Q8 goes ON, the number 8 and 9 pin of IC1 goes L, and the number 10 pin goes H. This causes the number 9 pin of IC2 to go H, resulting in the number 15 pin also going H.
3. Then, since the number 3 pin (number 8 pin) of IC3 goes H, the mechanism motor starts turning CW, starting the UP operation of the tonearm.
4. When the UP operation of the tonearm is completed (rack gear presses the UP completion switch S3), the number 12 pin of IC1 goes H causing the number 11 pin to go L, lowering the base voltage of transistor 3 and turning it OFF. Since Q4 also goes OFF, rotation of the turntable motor is stopped.
5. After UP operation has been completed, movement of the rack gear causes the tonearm to return to the armrest. The slide base then

moves to the OUT position and stops at the record-load position following the same operational procedure as listed in item 3 of loading out.

### ■ END SENSOR CIRCUIT

1. The construction of the end sensor circuit is shown in figure 4-5. When the tonearm reaches a point approximately 120mm from the center shaft, the shutter attached to the tonearm shaft passes between the lamp and CdS sensor blocking the light.
2. This causes the resistance value of CdS sensor to gradually rise, boosting the collector voltage of transistor Q5 (base potential fixed), and generates voltage between TP3 and TP4.

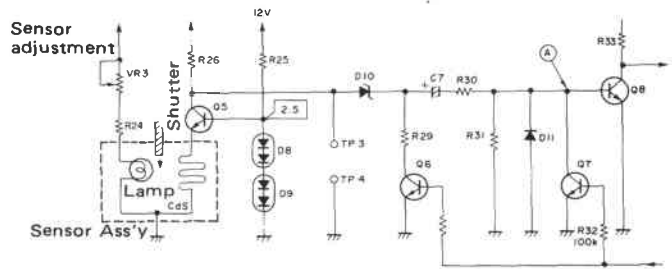

Fig. 4-5 End sensor circuit

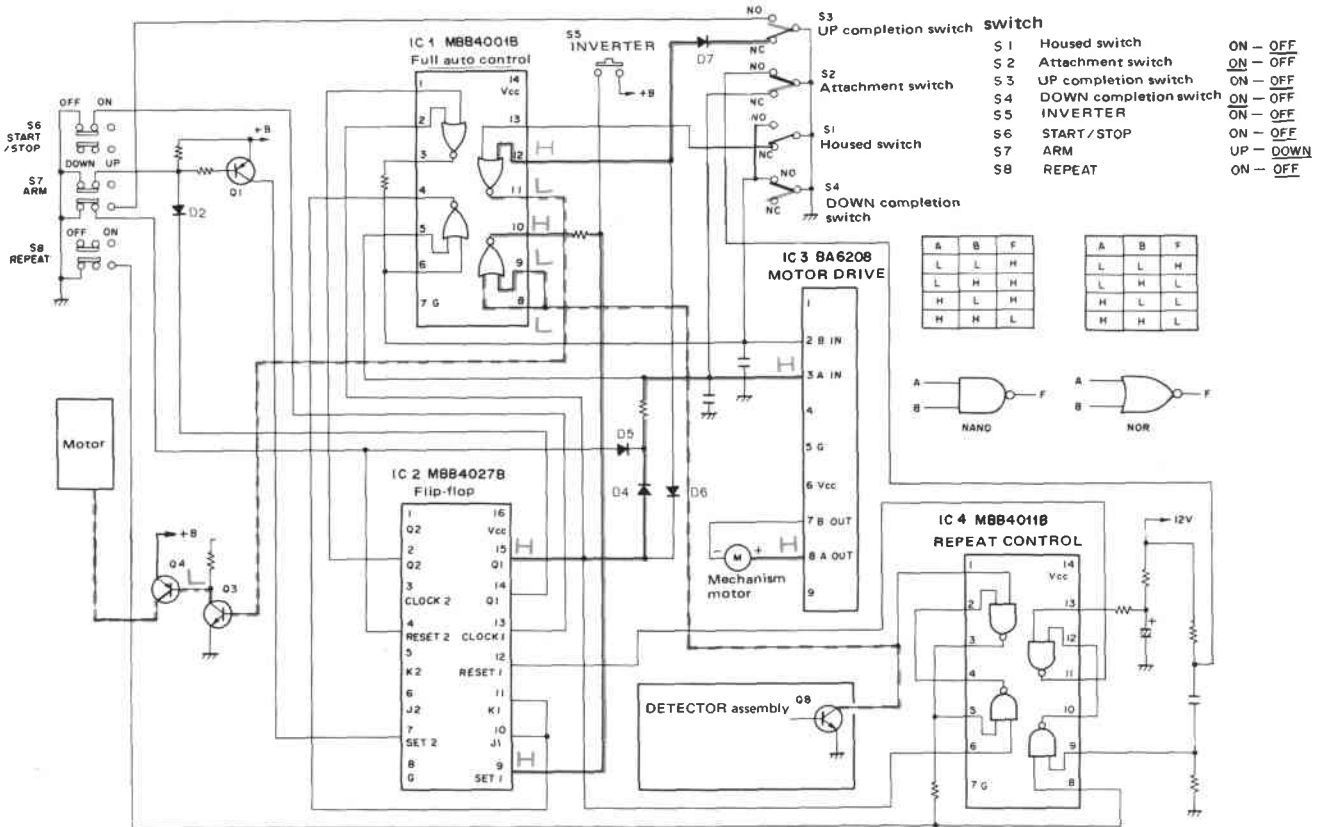

Fig. 4-4 Auto return

### 4.2 AUTO LEAD IN

1. Pressing the START/STOP button (switch S6) causes the number 13 pin of IC2 to change from L to H. When the number 13 pin goes to H, the number 15 pin will go to L, causing the number 2 pin of IC1 to go L.
2. The number 2 pin of IC1 going to L causes the number 3 pin to go to H. This in turn causes the number 2 pin (number 7 pin) of IC3 to go to H, and the mechanism motor starts rotating CCW, moving the turntable back in slightly.
3. Also, since the number 15 pin of IC2 is L, the number 12 pin of IC1 will go L through diode D6. When the number 12 pin goes L, the number 11 pin will go H, turning transistor Q3 ON.
4. Q3 going ON causes Q4 to also turn ON starting the turntable motor to rotating.
5. As the mechanism motor rotates CCW, the slide base starts moving from its record-load position inward. At this time, the record disc is pressing down on the sensing pin, inverting the record sensing plate and causing the slide base to stop when it reaches the playback position. At this point, the rack gear moves, rotating the driving plate. The tone arm then starts its lead in (refer to mechanism operation).
6. When the tonearm reaches the record disc size (30cm) position it stops. However, the rack gear continues moving, lowering the elevation shaft and pressing the down completion switch S4.
7. When the down completion switch S4 is pressed, the number 2 pin (number 7 pin) of IC3 goes L stopping the mechanism motor. This puts PL-X50 in a playback status.

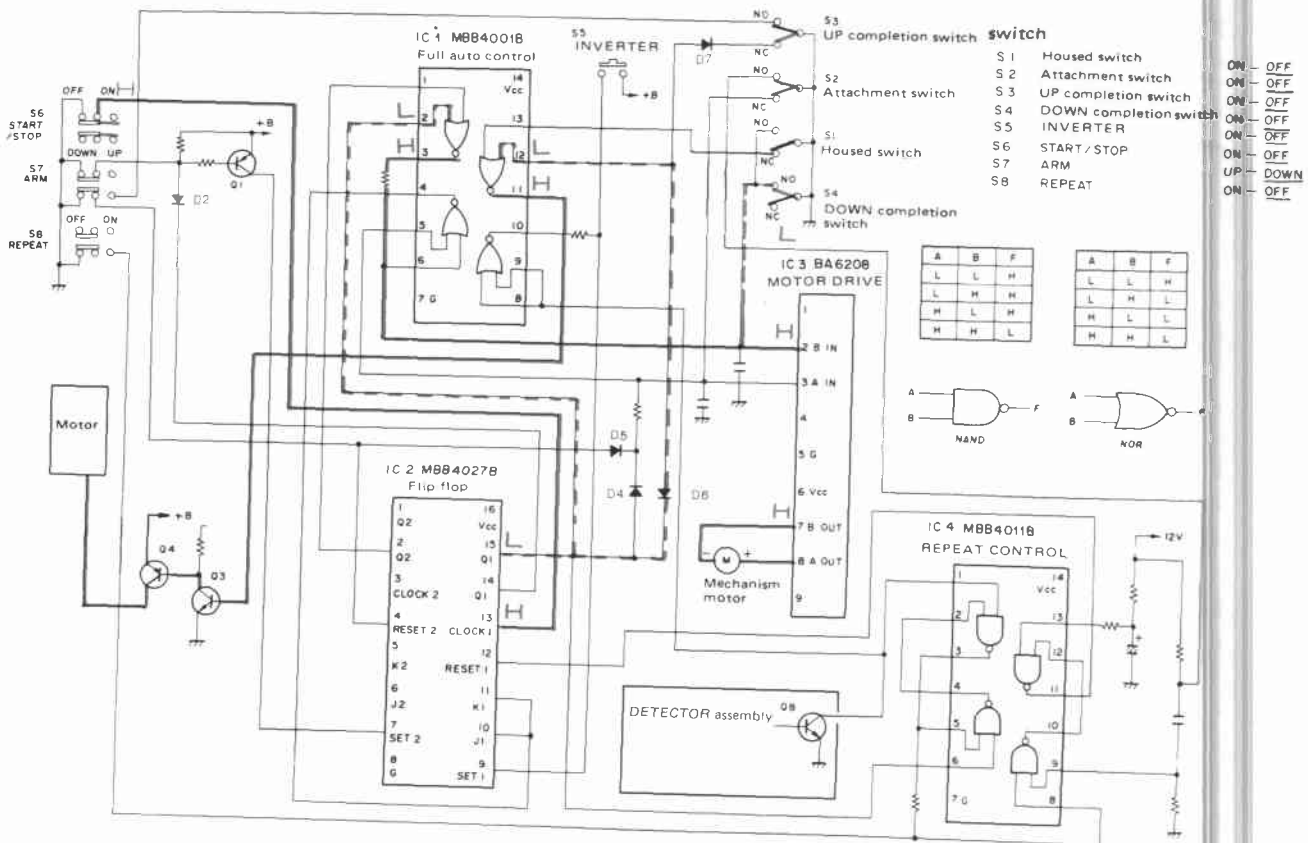

Fig. 4-2 Auto lead in

### 4.3 ARM ELEVATION UP/DOWN

1. If the ARM button (switch S7) is pressed during record playback (UP position), transistor Q1 goes OFF. With Q1 OFF, the number 7 pin of IC2 goes L. Also, since the number 4 of IC2 goes H, the number 2 pin also goes H.
2. When the number 2 pin of IC2 goes H, the number 1 pin of IC1 also goes H, and the number 3 pin goes L. This causes the number 2 pin (number 7 pin) of IC3 to go L. On the other hand, since the number 4 pin of IC2 is H, the number 3 pin (number 8 pin) of IC3 also goes H, starting the mechanism motor to rotating in a CW direction.
3. As the mechanism motor rotates, movement of the rack gear rotates the driving plate, raising the elevation shaft.
4. Then as the rack gear depresses the UP completion switch S3, the number 4 pin of IC2 goes L, causing the number 3 pin (number 8 pin) of IC3 to also go L, stopping the mechanism motor.
5. As the ARM button (switch S7) is pressed (DOWN position), transistor Q1 goes ON, and the number 7 pin of IC2 goes H, and the number 2 pin goes L. Since this causes the number 1 pin of IC1 to go L, the number 3 pin goes H.
6. When the number 2 pin (number 7 pin) of IC3 goes H, the mechanism motor turns CCW. Operation hereafter is the same as item 5 and 6 in the auto lead in section until DOWN operation is completed and playback status is entered.
7. If the ARM button (switch S7) is placed in the DOWN or UP position during UP or DOWN operation, the specified DOWN or UP operation will immediately be entered.

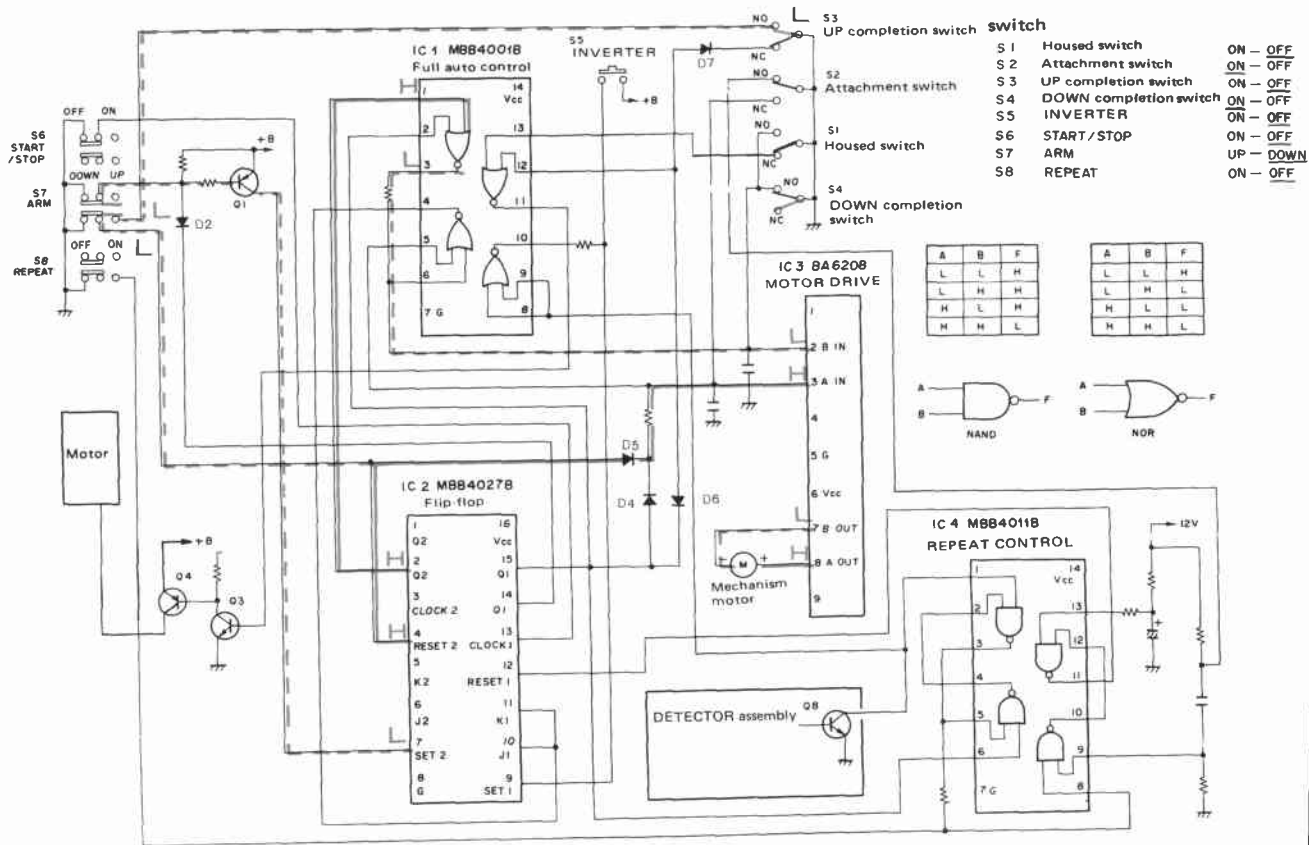

Fig. 4-3 Arm elevation UP/DOWN

### 4.3 ARM ELEVATION UP/DOWN

1. If the ARM button (switch S7) is pressed during record playback (UP position), transistor Q1 goes OFF. With Q1 OFF, the number 7 pin of IC2 goes L. Also, since the number 4 of IC2 goes H, the number 2 pin also goes H.
2. When the number 2 pin of IC2 goes H, the number 1 pin of IC1 also goes H, and the number 3 pin goes L. This causes the number 2 pin (number 7 pin) of IC3 to go L. On the other hand, since the number 4 pin of IC2 is H, the number 3 pin (number 8 pin) of IC3 also goes H, starting the mechanism motor to rotating in a CW direction.
3. As the mechanism motor rotates, movement of the rack gear rotates the driving plate, raising the elevation shaft.
4. Then as the rack gear depresses the UP completion switch S3, the number 4 pin of IC2 goes L, causing the number 3 pin (number 8 pin) of IC3 to also go L, stopping the mechanism motor.
5. As the ARM button (switch S7) is pressed (DOWN position), transistor Q1 goes ON, and the number 7 pin of IC2 goes H, and the number 2 pin goes L. Since this causes the number 1 pin of IC1 to go L, the number 3 pin goes H.
6. When the number 2 pin (number 7 pin) of IC3 goes H, the mechanism motor turns CCW. Operation hereafter is the same as item 5 and 6 in the auto lead in section until DOWN operation is completed and playback status is entered.
7. If the ARM button (switch S7) is placed in the DOWN or UP position during UP or DOWN operation, the specified DOWN or UP operation will immediately be entered.

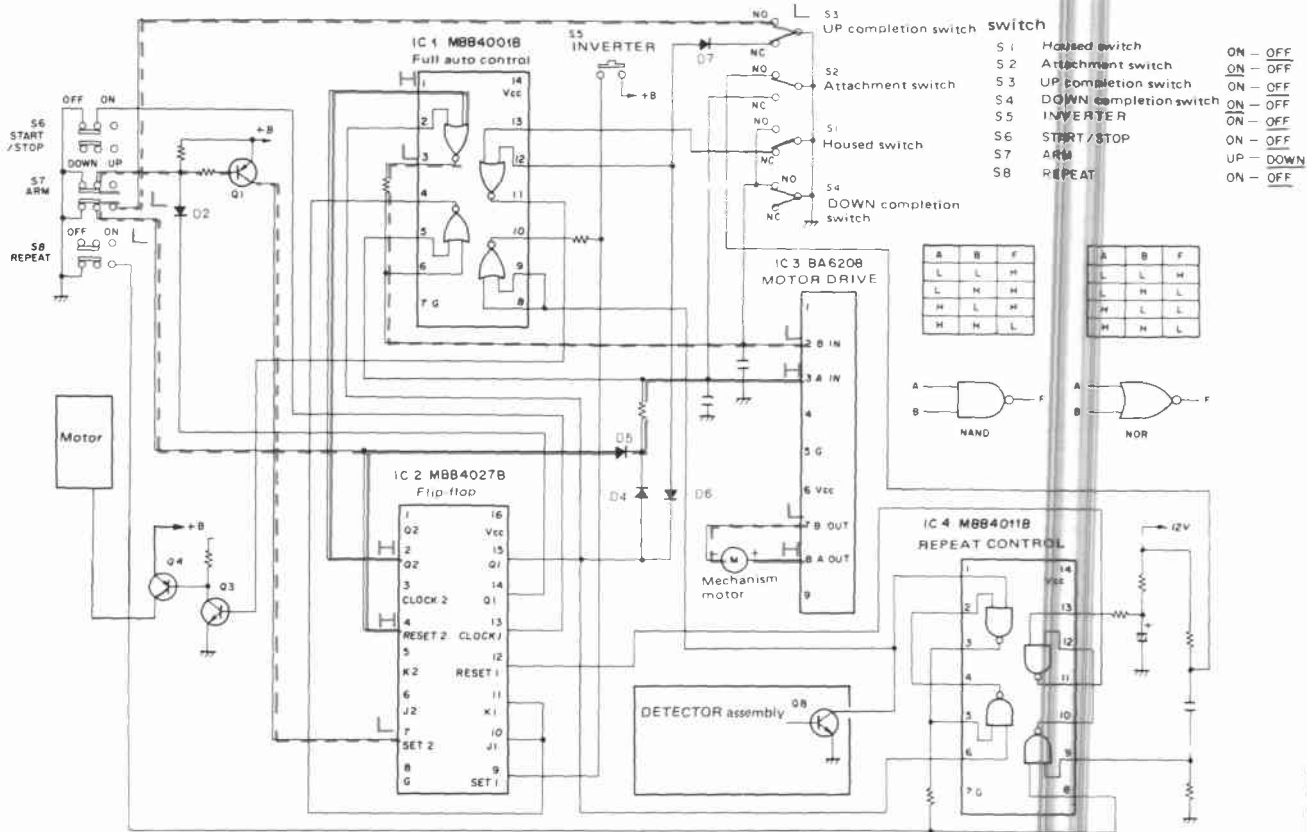

Fig. 4-3 Arm elevation UP/DOWN



### 4.2 AUTO LEAD IN

1. Pressing the START/STOP button (switch S6) causes the number 13 pin of IC2 to change from L to H. When the number 13 pin goes to H, the number 15 pin will go to L, causing the number 2 pin of IC1 to go L.
2. The number 2 pin of IC1 going to L causes the number 3 pin to go to H. This in turn causes the number 2 pin (number 7 pin) of IC3 to go to H, and the mechanism motor starts rotating CCW, moving the turntable back in slightly.
3. Also, since the number 15 pin of IC2 is L, the number 12 pin of IC1 will go L through diode D6. When the number 12 pin goes L, the number 11 pin will go H, turning transistor Q3 ON.
4. Q3 going ON causes Q4 to also turn ON starting the turntable motor to rotating.
5. As the mechanism motor rotates CCW, the slide base starts moving from its record-load position inward. At this time, the record disc is pressing down on the sensing pin, inverting the record sensing plate and causing the slide base to stop when it reaches the playback position. At this point, the rack gear moves, rotating the driving plate. The tone arm then starts its lead in (refer to mechanism operation).
6. When the tonearm reaches the record disc size (30cm) position it stops. However, the rack gear continues moving, lowering the elevation shaft and pressing the down completion switch S4.
7. When the down completion switch S4 is pressed, the number 2 pin (number 7 pin) of IC3 goes L stopping the mechanism motor. This puts PL-X50 in a playback status.

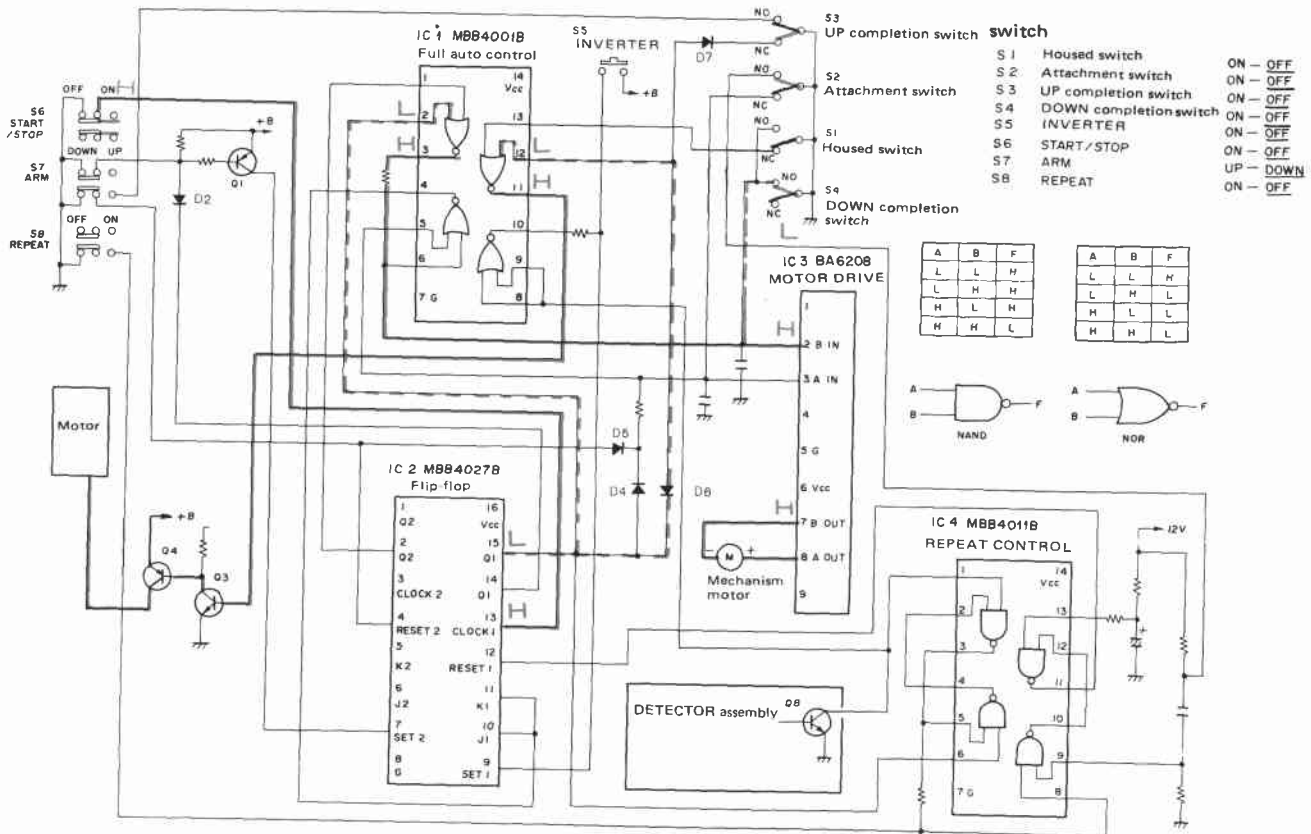

Fig. 4-2 Auto lead in

- This signal passes through D10 (peak hold diode), and is applied to the differential circuit consisting of C7, R30, and R31. This differential circuit serves to convert the tonearm position signal into a speed signal.

- Peak hold diode

Serves to prevent misoperation due to eccentricity in the record disc.

- As the tonearm stylus moves into the record disc lead-out groove, its movement becomes faster, and when the potential at point A rises above approximately 0.6V, Q8 comes ON, dropping the potential of the collector side. This serves as an end sensor signal sending the number 8 and 9 pin of IC1 L.
- When the tonearm is UP, transistor Q6 and Q7 prevent transistor Q8 from turning ON.

#### 4.5 AUTO STOP

- When the START/STOP button (switch S6) is pressed during record playback, the number 13 pin of IC2 goes from L to H, and the number 15 pin goes H.
- When the number 15 pin goes H, the number 3 pin (number 8 pin) of IC3 also goes H, starting the mechanism motor in the CW direction and

entering UP operations.

- After UP operations are completed, the tonearm returns to the armrest following the operations listed in items 4 and 5 of the auto return section, and the slide base stops at the record-load position.

With the ARM button (switch S7) in the UP position and transistor Q1 in an OFF status, the number 7 pin of IC2 is L, and the number 2 pin is H, and the number 1 pin of IC1 is H. In this status, the number 3 pin is held L no matter whether the signal input to the number 2 pin of IC1 is L or H, thereby making it impossible for the number 2 pin (number 7 pin) of IC3 to go H. The mechanism motor therefore cannot turn CCW. At this point, when the START/STOP button (switch S6) is switched to the ON position and the number 13 and number 15 pin of IC2 goes H, the number 14 pin will go L turning transistor Q1 ON and changing the number 7 pin of IC2 to H, the number 2 pin to L, and the number 1 pin of IC1 to L.

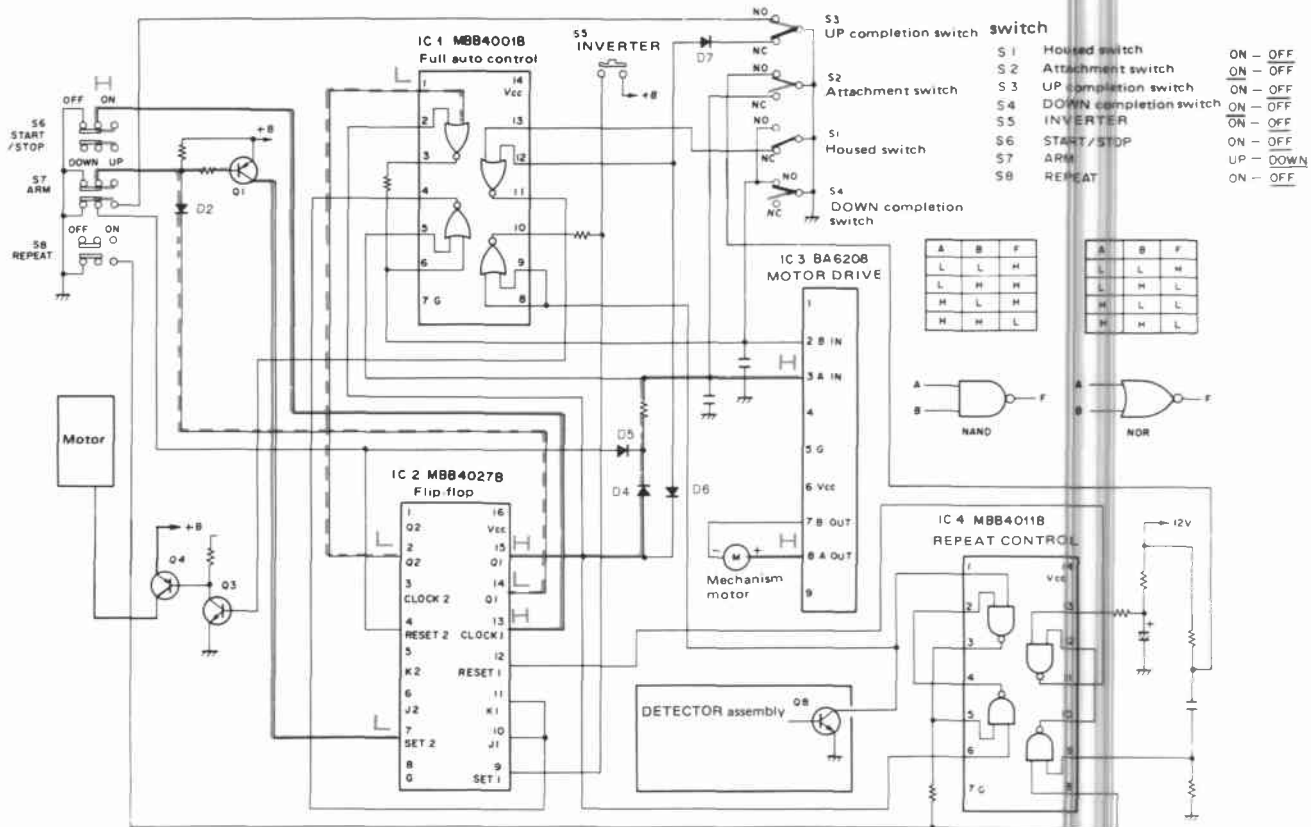

Fig. 4-6 Auto stop

4.6 AUTO REPEAT

1. When the REPEAT button (switch S8) is pressed, switch S7 goes to the ON position, and the number 8 pin of IC4 is opened to L, making it the same logic level as pin number 3.
2. With switch S8 in the ON position (auto repeat status), operating auto return causes the end sensor circuit (transistor Q8) to come ON, and the number 1 pin of IC4 to go L. The number 3 pin and number 8 pin go H (in auto return, when the number 15 pin of IC2 is H, the number 6 pin of IC4 is H. When the number 3 pin is L, the number 1 and number 2 pin are L, and the number 3 pin is H).
3. After the tonearm has completed lead-out and returned to the armrest, the slide base moves, opening attachment switch S2, and the number 9 pin of IC4 is held H for the duration of the charging of capacitor C6. This causes the number 10 and number 12 pin to momentarily go L.
4. When the number 11 pin of IC4 goes H, and the number 12 pin of IC2 goes H, the number 15 pin will go L to execute lead-in. Operations thereafter are the same as auto lead-in.

When the START/STOP button (switch S6) is pressed placing the unit in an auto stop status, the repeat status cannot be entered even though the REPEAT button (switch S8) is depressed.

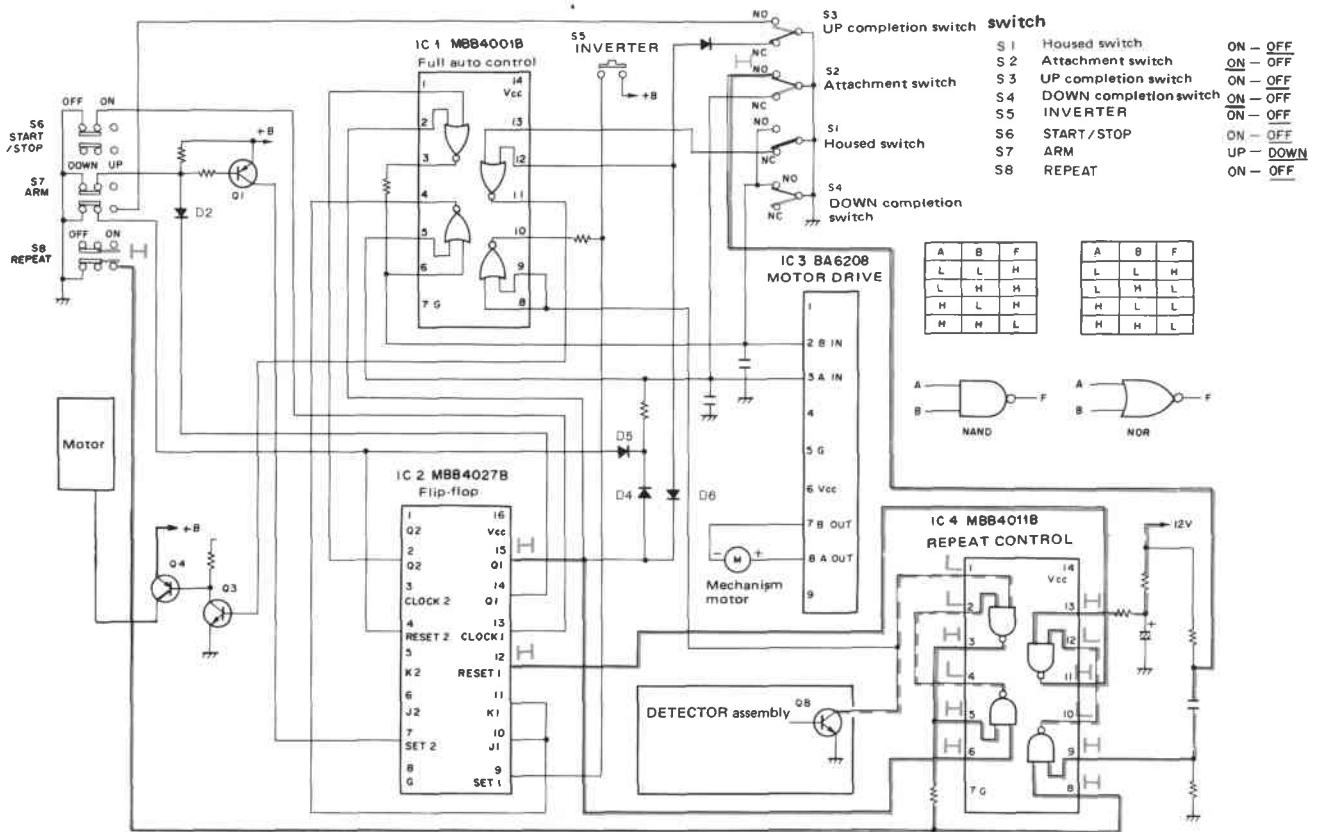
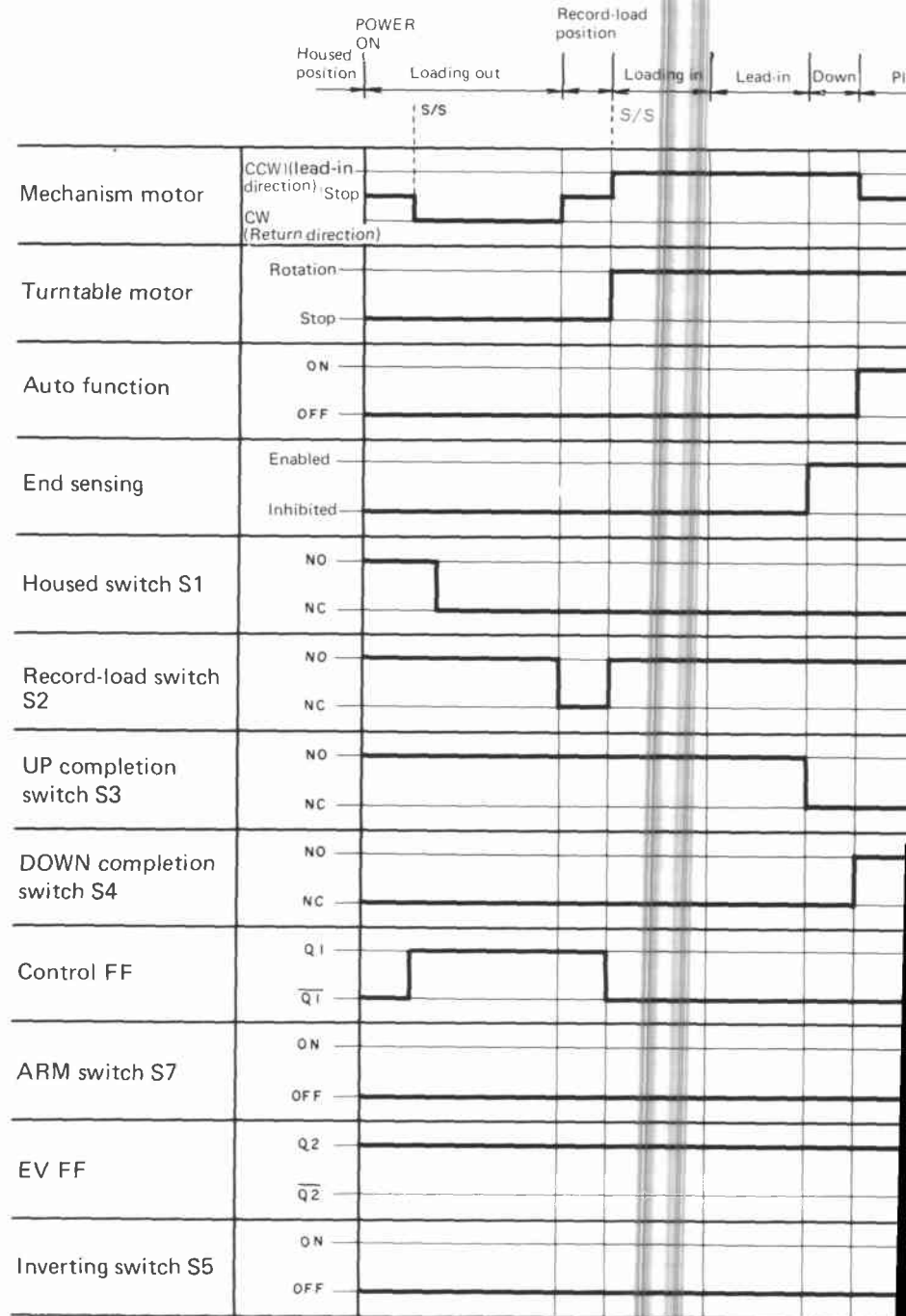

Fig. 4-7 Auto repeat

4.9 TIMING CHART 1 (REPEAT SWITCH OFF)



Notes:

- S/S indicates pressing the START/STOP button.
- Indicates the direction of rotation of the mechanism motor.
- S1 ~ S4 indicates the direction of switch connection.
- FF shows whether the H signal is from Q or Q-bar.
- Auto function indicates the output status.
- Loading out and other operational status are shown in Figure 4-10.

- a : Loading out
- b : Loading in
- c : Lead-in
- d : Lead-out

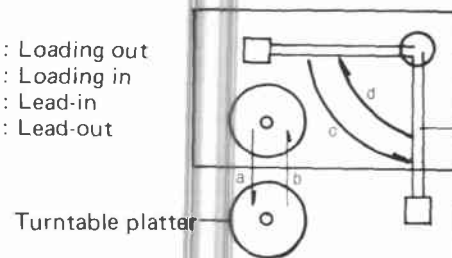
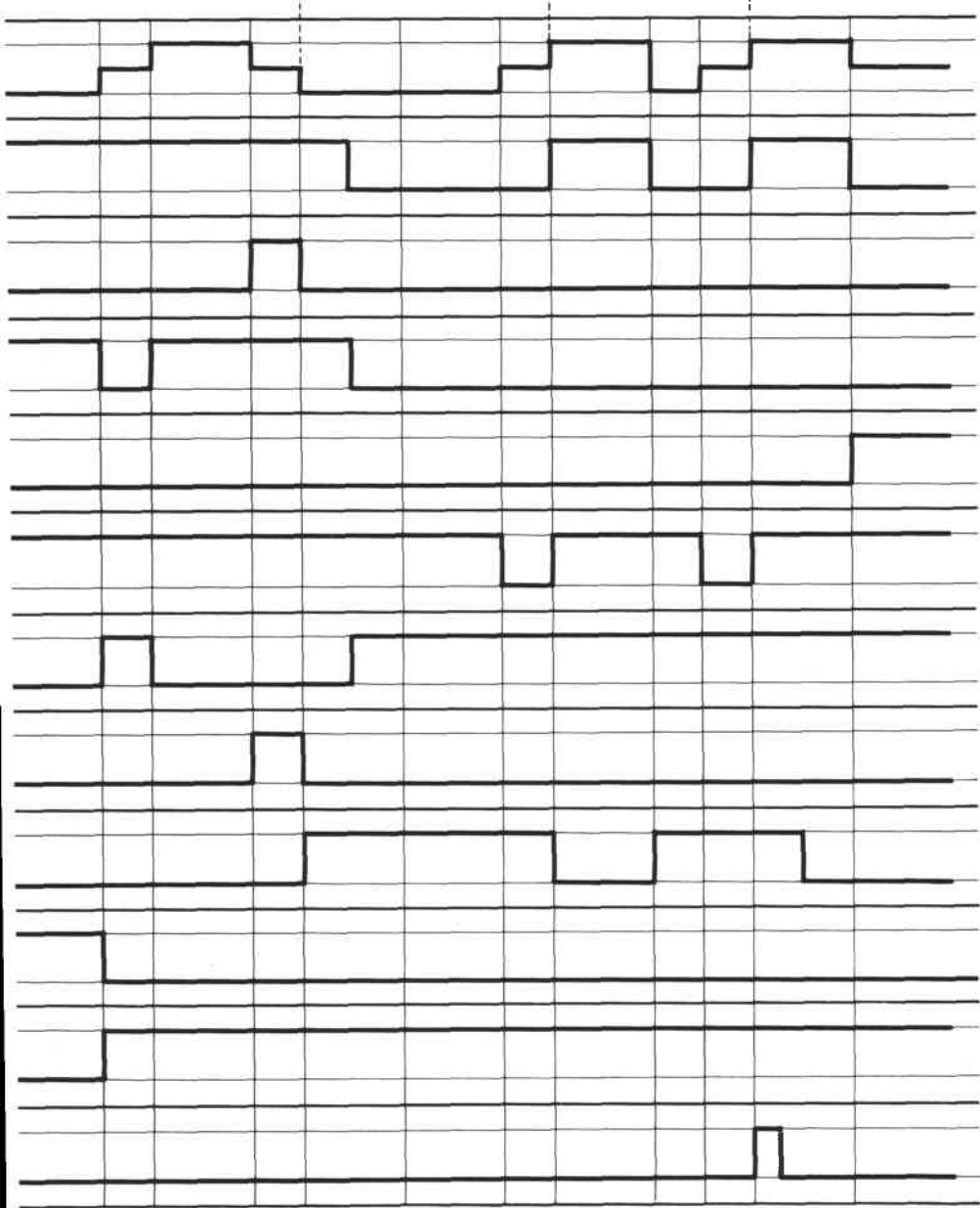
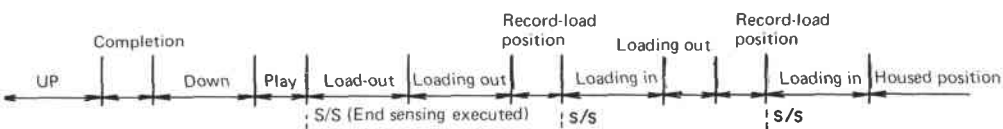

Fig. 4-10 Turntable position



earn

#### 4.7 LOADING IN

1. When the START/STOP button (switch S6) is pressed while the unit is at the record-load position (throwing switch S6 to the ON side), the number 13 pin of IC2 changes from L to H.
2. When the number 13 pin of IC2 goes to H, the number 1 and 2 pin of IC1 goes to L, and the 3 pin goes to H. The number 2 pin (number 7 pin) of IC3 goes to H, starting the mechanism motor to rotating CCW.

Since the number 12 pin of IC1 goes L, the number 11 pin goes H, and transistor Q3 and Q4 turn ON for turntable motor rotation.

3. As the mechanism motor rotates, the slide base moves from the record-load position toward the housed position. When the slide base reaches the housed position, it presses the housed switch S1, causing pin number 2 (pin number 7) of IC3 to go L, thereby stopping the mechanism motor.

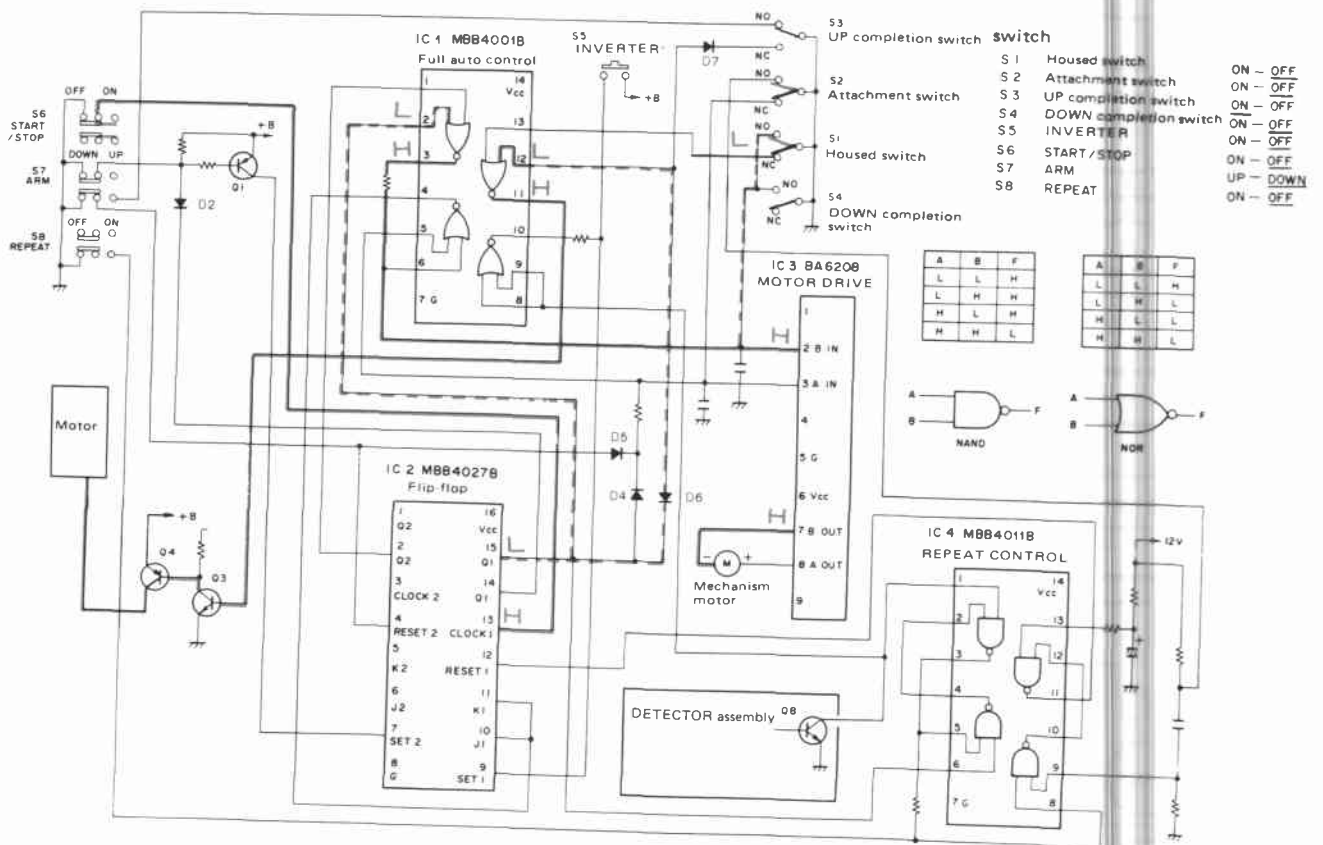

Fig. 4-8 Loading in

### 4.8 RECORD DISC PROTECTION SWITCH

1. The inverting switch S5 is attached to the back side of PL-X50. If the loading in status (lead-in not executed) is entered with a 30cm record disc placed on the platter, either the record disc or the turntable unit will be damaged. Switch S5 serves to guard against this.
2. When the record disc is pressing switch S5, the number 9 and number 15 pin of IC2 are held H. This causes the number 3 pin (number 8 pin) of IC3 to remain H, causing the mechanism motor to rotate CW.

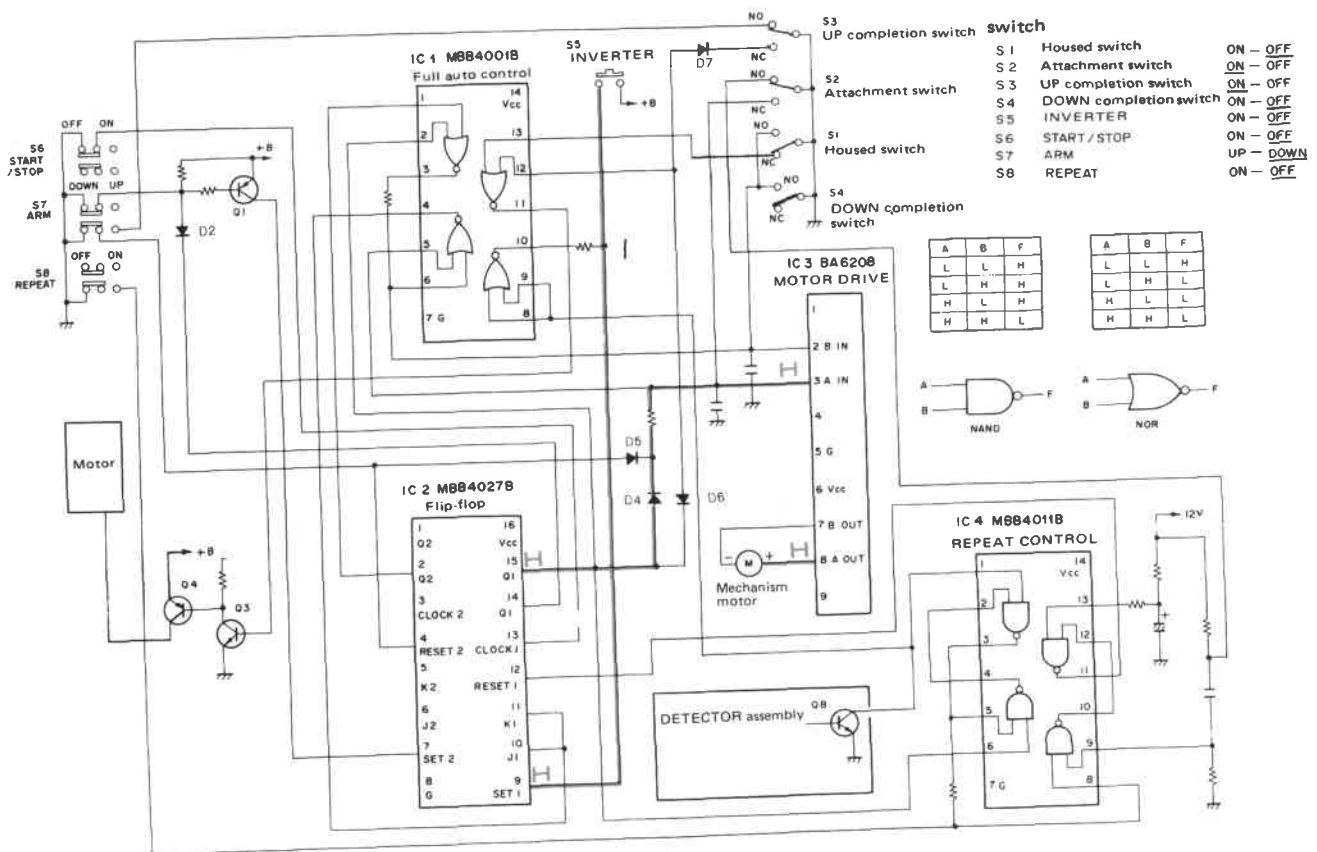

Fig. 4-9 Record disc protection switch

# 5. MAJOR COMPONENT ASSEMBLY/DISASSEMBLY

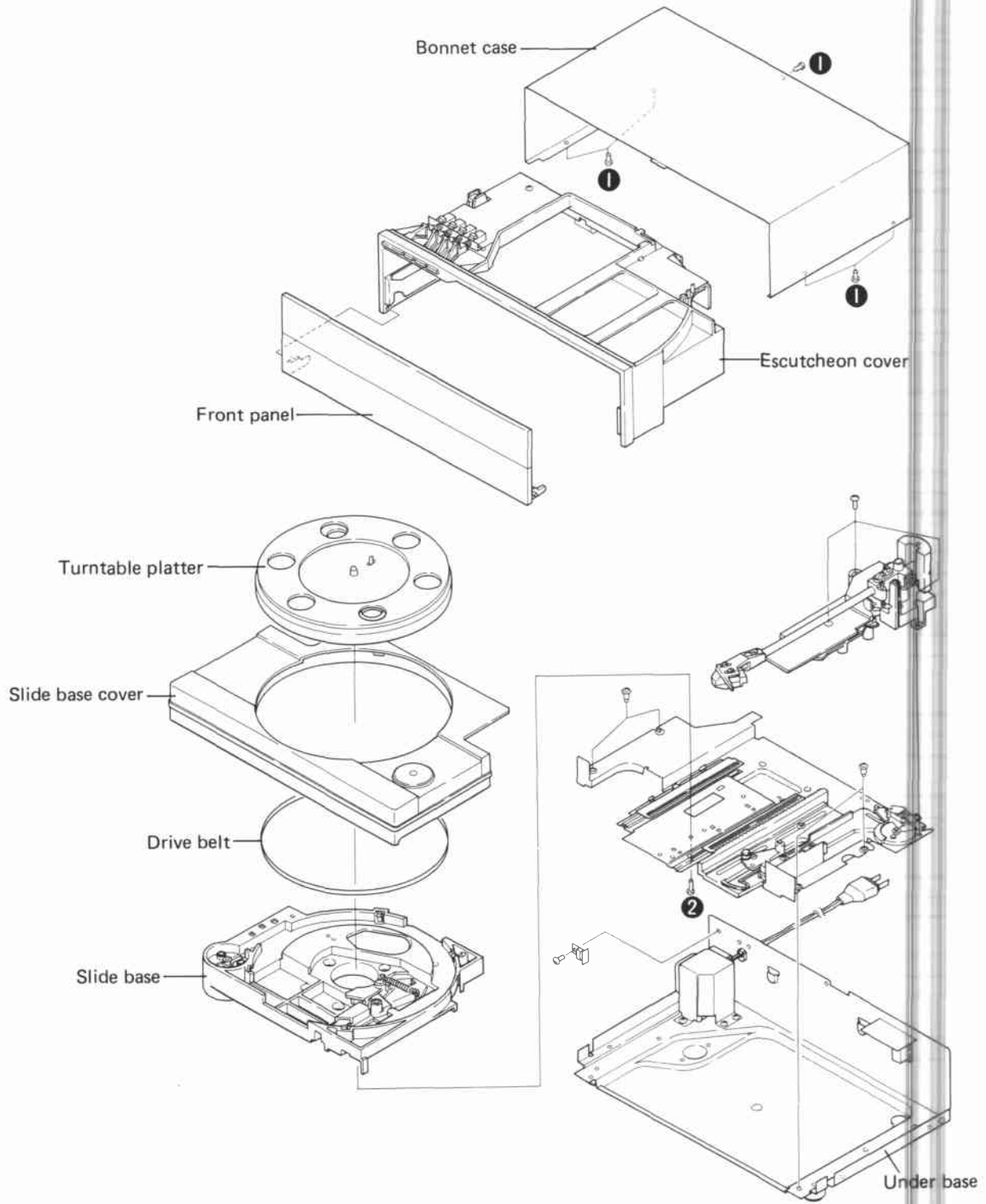

Fig. 5-1 Disassembly



1. Depress the START/STOP button to bring the turntable unit out, and unplug the line cord from the receptacle.
2. Remove the bonnet case (hood) by loosening screw ①.

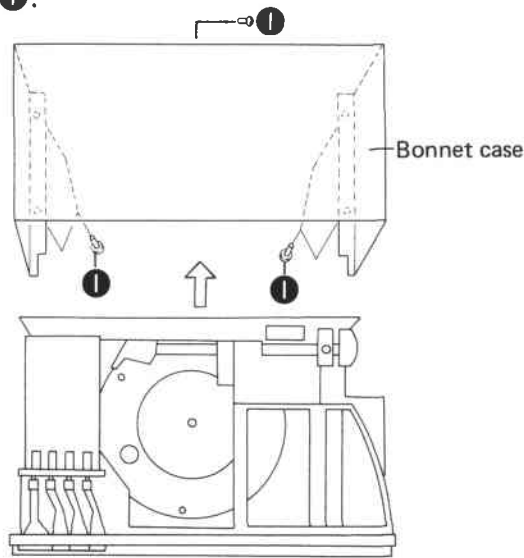

Fig. 5-2 Bonnet case remove

3. The escutcheon cover is inserted in the base of the main unit. First, pull out on the front side of the escutcheon cover and remove the front panel.
4. Wiring from the transformer, tonearm, and auto function is located on the rear side of the escutcheon cover. Remove these wires by desoldering. Also remove the end sensor connector (Figure 5-3).

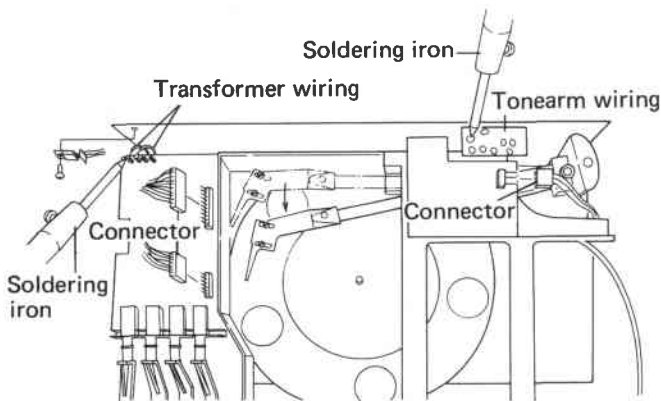

Fig. 5-3 Escutcheon cover removal

#### FRONT PANEL ATTACHMENT

Insert the front panel into the escutcheon cover and insert the whole unit into the base. Hook latches are located at two points (left and right) in the front and two points

in the rear. Opening and closing of the front panel turns the power switch ON/OFF. To set the power switch, after the front panel has been attached, with the panel closed, place your thumb over the pivot of the power switch lever, and while applying pressure rotate the lever toward the microswitch (in the direction of the arrow) until a click is heard. This operation is performed with the slide base in the housed position (Figure 5-4).

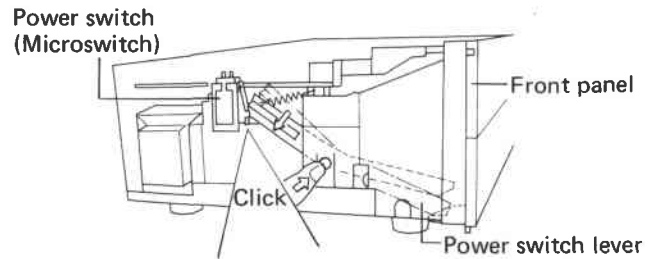

Fig. 5-4 Power switch attachment

5. When the escutcheon cover is removed for operational checks, etc., disconnecting the end sensor connector and bringing it out to the front of the escutcheon cover and then rotating it 180 degrees to the rear of the unit will make the check easier.

#### Note:

Since opening and closing of the front panel of PL-X50 turns the power switch ON/OFF (through the power switch lever), always place the power switch to the ON position for operational checks. (Use a screwdriver to depress the microswitch actuator.)

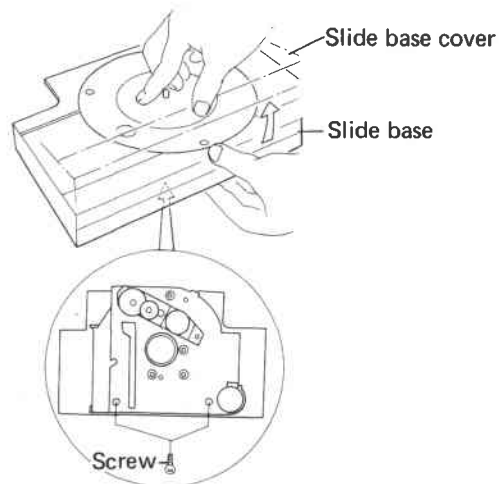
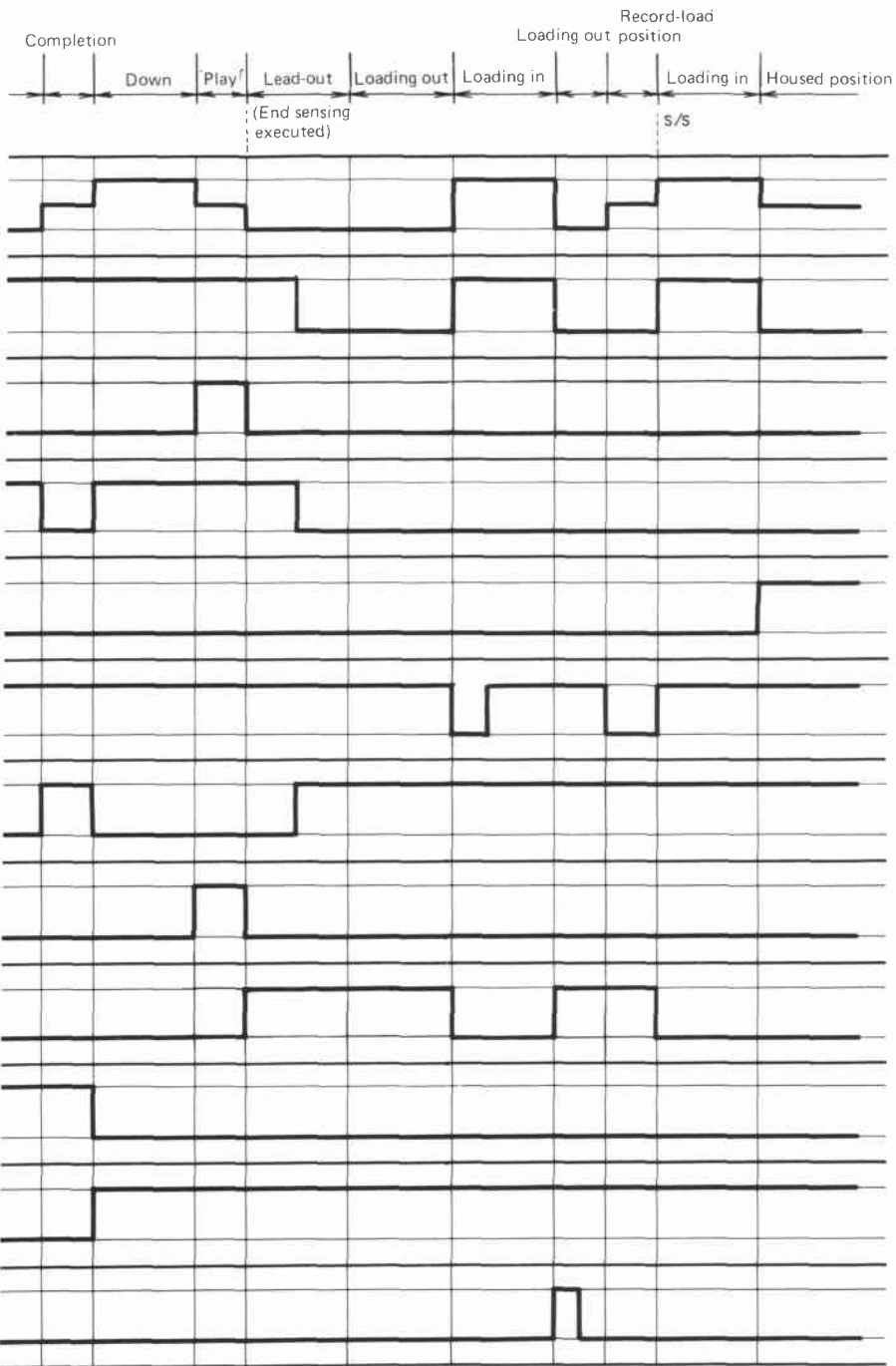

Fig. 5-5 Slide base remove





6. The slide base cover is held by hooks in the slide base. The front section is secured by screws in two places. The screws are loosened as shown in Figure 5-5, and the slide base cover is lifted up from the forward side of the slide base while holding the platter to prevent it from coming off.
7. The turntable is not easily separated from its bearing assembly with the PL-X50. For removal, the slide base must be in the record-load position (record disc loading position), and screw ② removed from the bottom side of the slide rail. The bearing assembly and platter will come off together. Since the drive belt is still attached to the platter, be careful not to damage the belt.

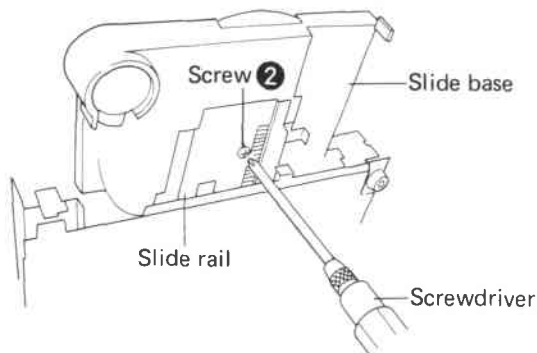

Fig. 5-6 Turntable platter remove

**ATTACHING THE TURNTABLE PLATTER (WITH BEARING ASSEMBLY)**

Place the unit on the slide rail and insert the bearing assembly in the opening in the center of the slide base. Lightly secure screw ② from the bottom side of the slide rail. Then with a small screwdriver inserted between the turntable platter and the slide rail, gently tap the projection on the outer circumference of the attachment flange while

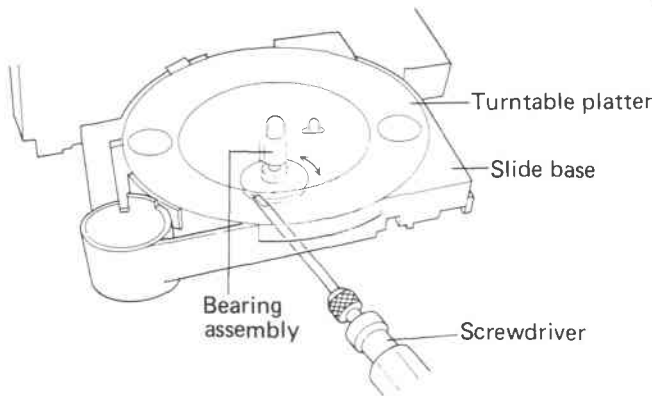

Fig. 5-7 Turntable platter attachment

rotating the bearing assembly. (This is to seat the projection in the slot to prevent the bearing assembly from rotating.) After the bearing assembly is firmly seated and will not rotate, securely tighten screw 2 on the bottom of the slide rail (Figure 5-7). After the turntable platter (bearing assembly) is secured, replace the drive belt.

8. The slide base can be removed by loosening screw ③ (Figure 5-8).

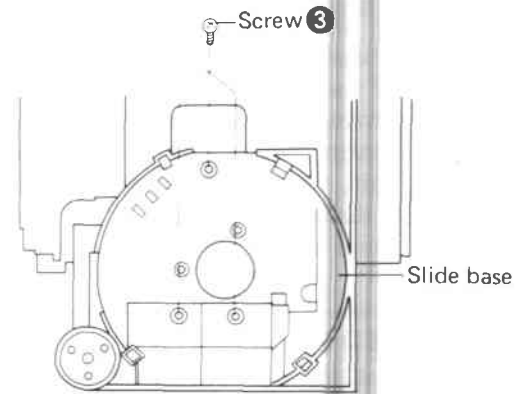

Fig. 5-8 Slide base remove

**SLIDE BASE ATTACHMENT**

Position the slide rail approximately 20mm inward from the record-load position, and line the slide base up with the positioning hole of the slide rail. At this time, the lock lever assembly should be attached, but disengaged from the rack (the lock lever assembly is pressed toward the slide base side by the lock lever reset plate) (Figure 5-9). Now, manually rotate the slide base drive motor pulley CCW to return the slide base to its record-load position. Finally, set the record-load detection plate and record-load detection reset plate to the record-load setting (Figure 5-10).

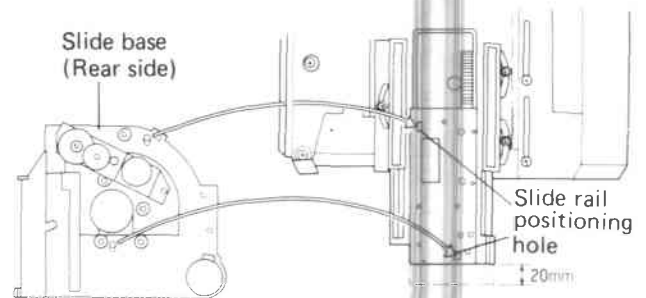

Fig. 5-9 Slide base attachment 1

## 6. OPERATIONAL DESCRIPTION

### 6.1 BASIC OPERATION OF THE SLIDE BASE

With the PL-X50, the turntable platter and tonearm is normally inside the bonnet cover (hood). Thus, record playback is not immediately possible.

1. Opening the door (front panel) presses the power switch lever and causes the power switch to come ON.
2. When the START/STOP button is pressed, the turntable moves to an OUT position. A 30cm or 17cm record disc is then loaded.
3. After the record disc is loaded and the START/STOP button is pressed again, the platter starts rotating and the unit retreats approximately 60mm inward. The tonearm then operates to start playback.

Housed position

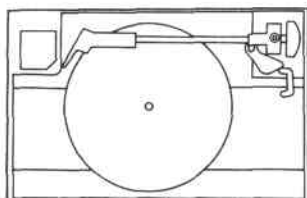

START/STOP button ON

Record-load position  
(record disc)

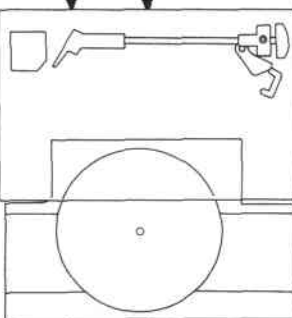

START/STOP button ON



Playback position

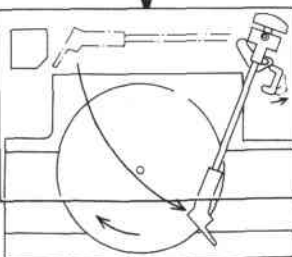

START/STOP button ON  
(End sensing)

After arm return, slide base moves forward.

The slide base moves through the differential operation of the reduction gear and rack gear. Operation of the rack gear moves the tonearm when a record disc is sensed.

The presence or absence of a record disc is sensed by the record disc sensing pin, and playback position or housed position is selected accordingly.

The index cam determines whether a 30cm disc or 17cm disc is loaded.

*Note: Turntable platter rotation is noted by the heavy black line.*

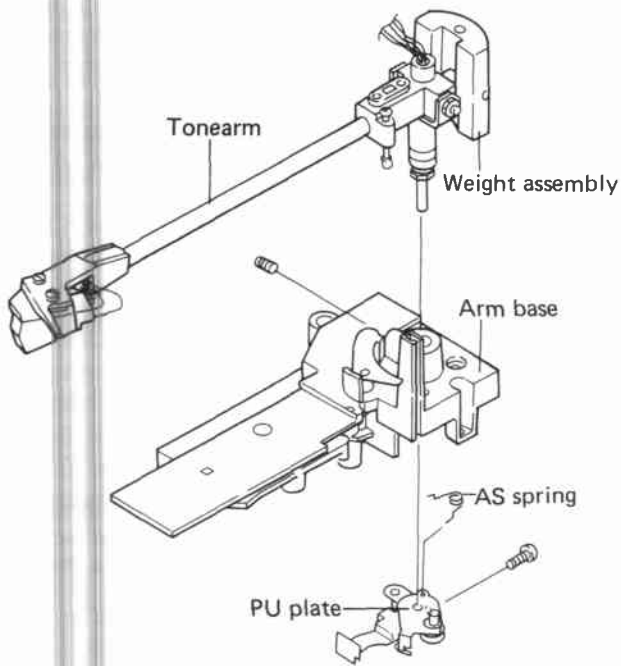

Fig. 5-15 Tonearm remove 1

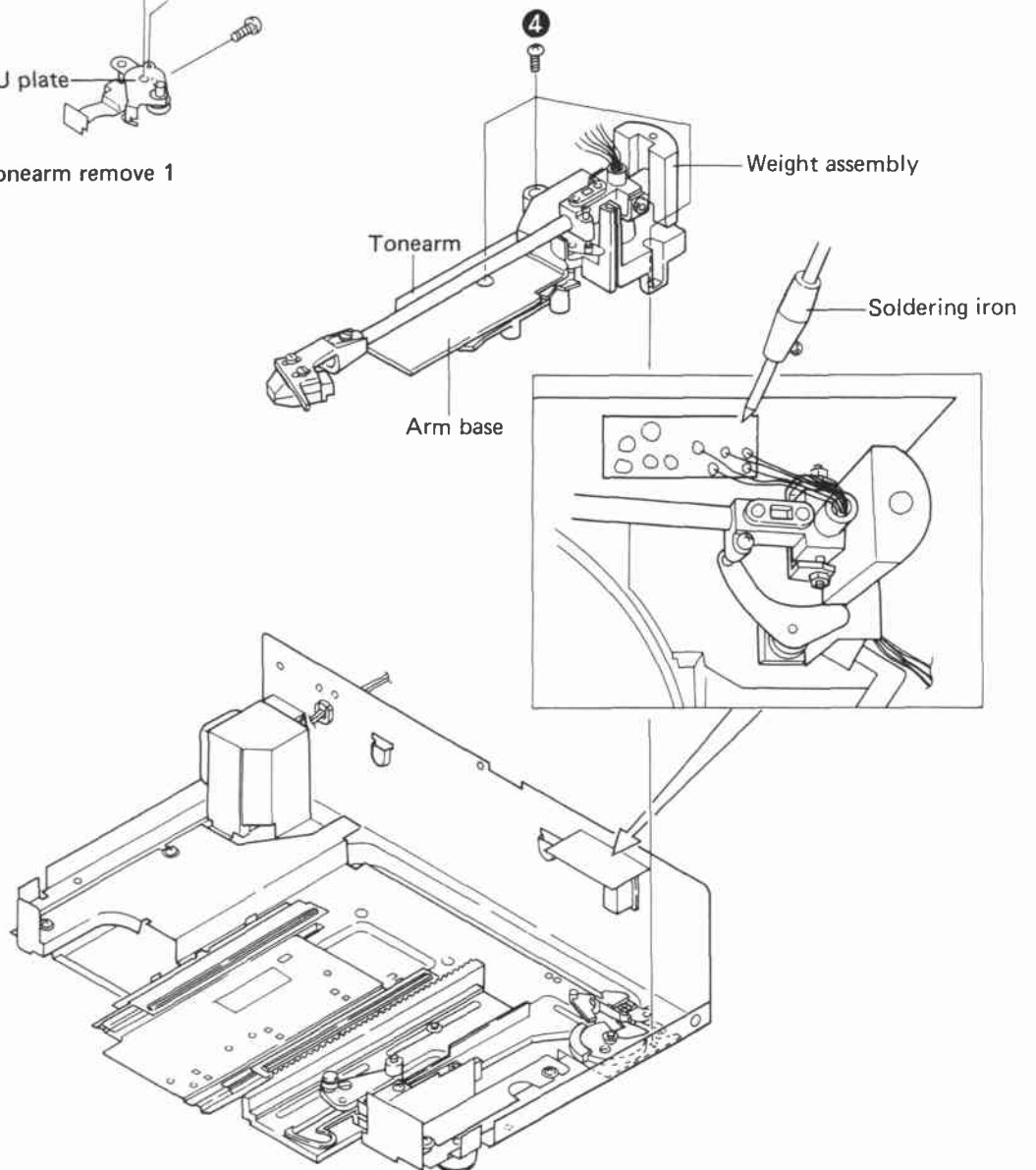

Fig. 5-16 Tonearm remove 2

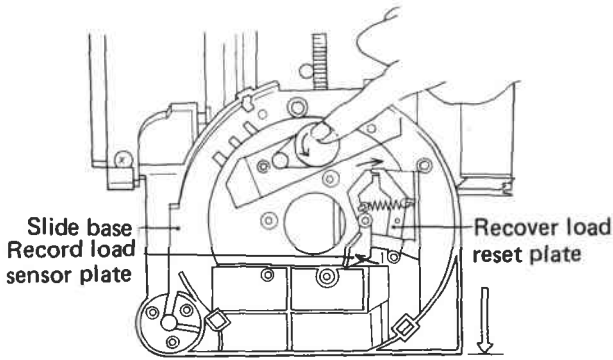

Fig. 5-10 Slide base attachment 2

- 9. The slide base drive motor is attached to the rear side of the slide base.
- 10. When removing the slide rail, be careful not to lose the bearings (when the bearings are in the retainer unit, they are held in by pressure and not easily dislodged, however, it is possible to dislodge them when inserting the unit into the slide rail).

**HALF-SPEED GEAR ASSEMBLY**

When assembling the half-speed gear, apply heavy torque grease to the area where the retainer unit is to be attached, and insert the half-speed gear. Line the slide rail hole up with the under base and retainer unit for assembly. Also, the half-speed gear is assembled in the housed position. After assembly, make certain the slide rail moves smoothly (amount of movement should exceed 120mm).

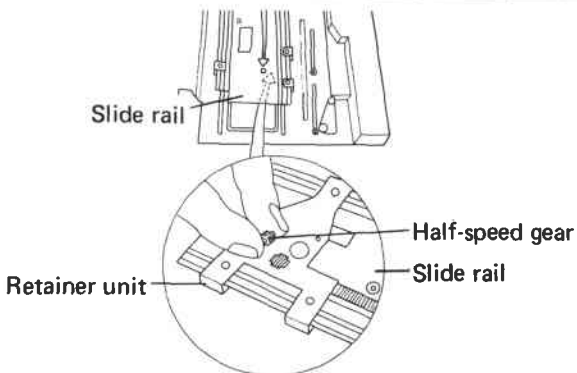

Fig. 5-11 Half-speed gear assembly

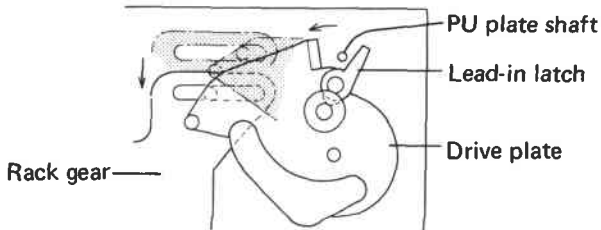

Fig. 5-12 Tone arm attachment

- 11. The tonearm section may be removed by loosening screw 4.
- 12. The tonearm section is assembled prior to assembling to the slide base. Also, attach the PU plate shaft positioned between the drive plate and the lead-in latch (slide the rack gear slightly forward and hold the lead-in latch in an open position during assembly. After assembly, return the rack to its back position) (Figure 5-12).

**PU PLATE ATTACHMENT**

The PU plate assembly should be assembled with the tonearm pipe parallel to the arm base. Both ends of the AS spring should be attached to the arm base and PU plate. Secure the plate when it is pushed all the way back to the tonearm pivot shaft. At this point, the adjustment cam should be positioned at the center of its rotation (Figure 5-14). At the same time, the (B) section of the PU plate assembled should be lined up with the 30cm lowering position of the index cam when it is secured (Figure 5-14).

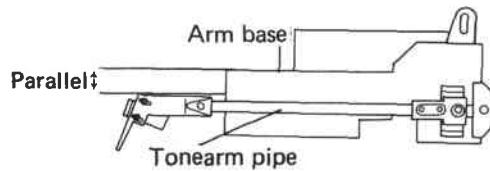

Fig. 5-13 PU plate attachment 1

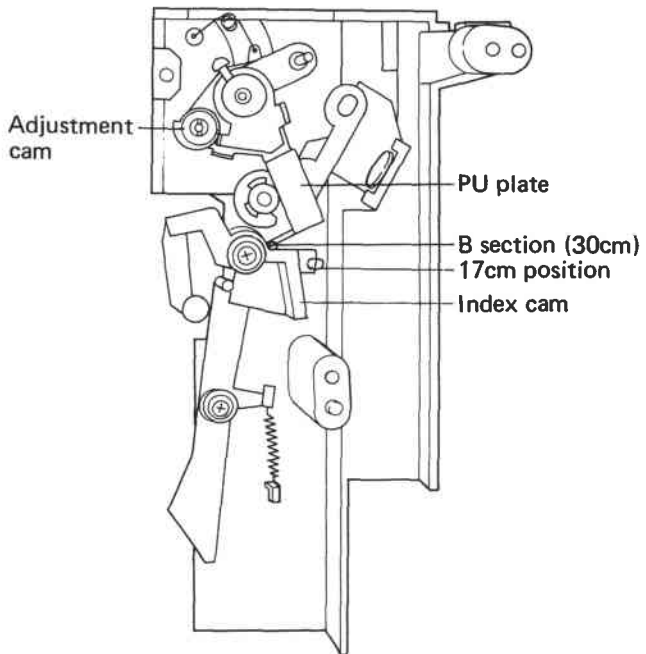

Fig. 5-14 PU plate attachment 2

The arm elevation button is normally left in the down position. Playback will not be automatic when this button is in the up position. Also, if the stylus has a cover on it, remove the cover in the up position, then return the button to the down position. The REPEAT button should be left in the OFF position.

5. When the record disc is removed, and the START/STOP button is depressed, the turntable platter will retreat to the housed position. Closing the door will complete all operations by turning off the power switch.

In item 4, if the record disc is changed and the START/STOP button is depressed, the turntable platter will move inward approximately 60mm and repeat the playback operation listed in item 3.

4. When record playback is completed, or when the START/STOP button is depressed during playback, the tonearm elevates and moves back (housed position) and the turntable platter moves to the out position.

6.2 MECHANISM FUNCTIONS DURING BASIC OPERATIONS

■ Operation of the Basic Components F (Flow Chart)

Red line (Record disc is loaded) →

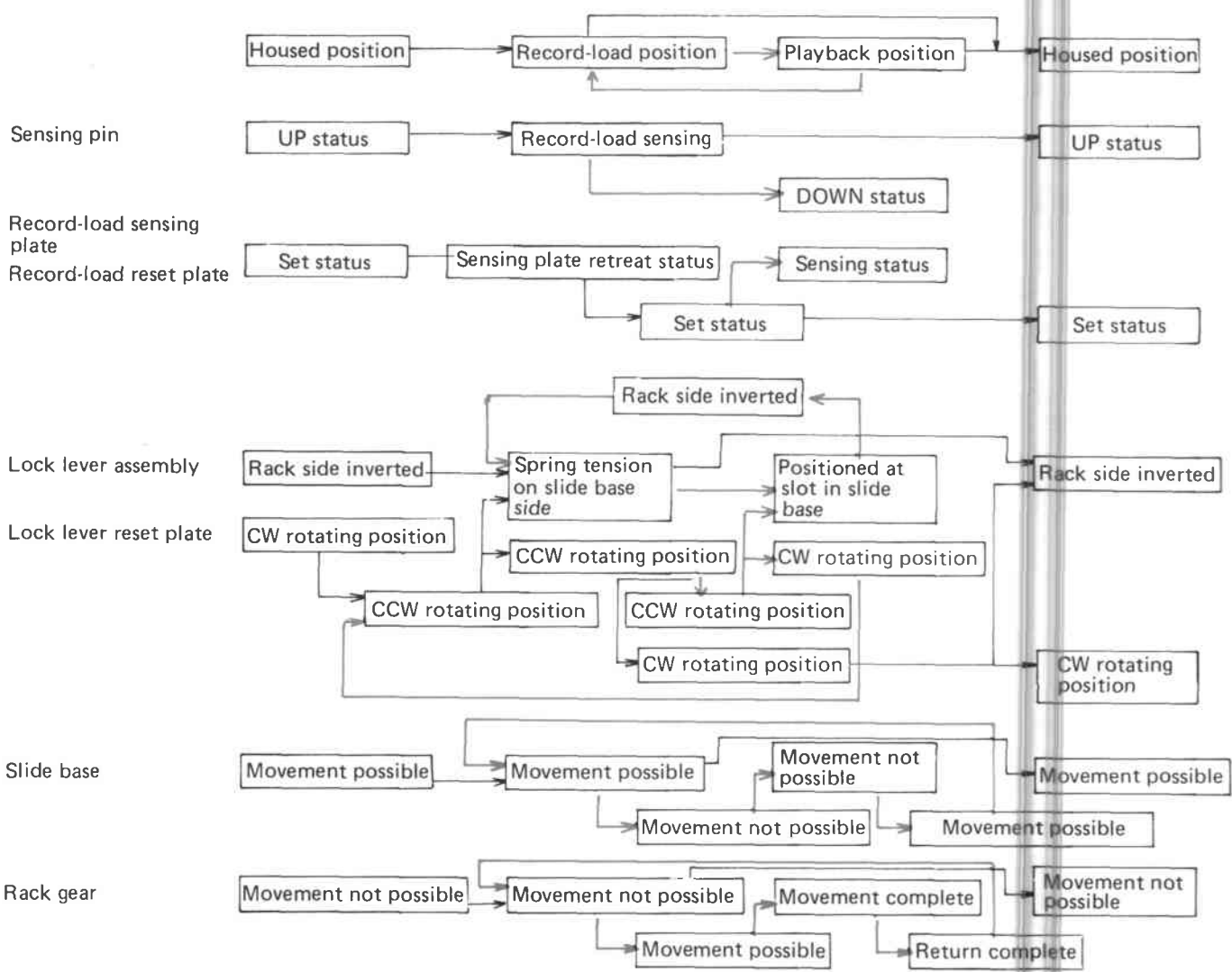



■ Operation Bringing the Slide Base (turntable platter) forward

1. The power switch on the PL-X50 is turned ON by opening the door (front panel). Pressing the START/STOP button causes the slide base drive motor to start rotating in a forward direction (refer to the circuit description).
2. The belt coupling the rotating motor with gear (A) causes the gear train consisting of (A), (B), and (C) to start rotating. Gear (C) is engaged with the rack gear.
3. The slide base is fixed to the slide rail, and will move in a forward and backward direction (if the lock lever assembly is disengaged from the rack gear). Additionally, if the lock lever assembly is disengaged from the rack gear, it will also move back and forth.
4. At the point operation is started, roller section A of the lock lever assembly engages in the depression of the rack gear, preventing it from moving.
5. Since the rack gear is immovable, the rotational force of the motor causes gear (C) to move along the rack gear thereby moving the

slide base (turntable platter) in a forward direction.

6. When the slide base has moved out approximately 120mm projection (A) on the slide base presses the attachment switch actuator and turns it OFF. This serves to stop the slide base drive motor from rotating (refer to the circuit description), and the slide base is left fully extended.

In this condition, if the START/STOP button is pressed again without a record disc loaded on the platter, the slide base drive motor starts rotating in a reverse direction (refer to the circuit description) moving the slide base back toward the housed position. When the fully housed position is reached, projection (B) on the slide base presses the housed switch actuator and turns it OFF. This stops the rotation of the slide base drive motor, and the slide base returns to its original position, also, as the slide base moves back, the turntable platter also starts rotating.

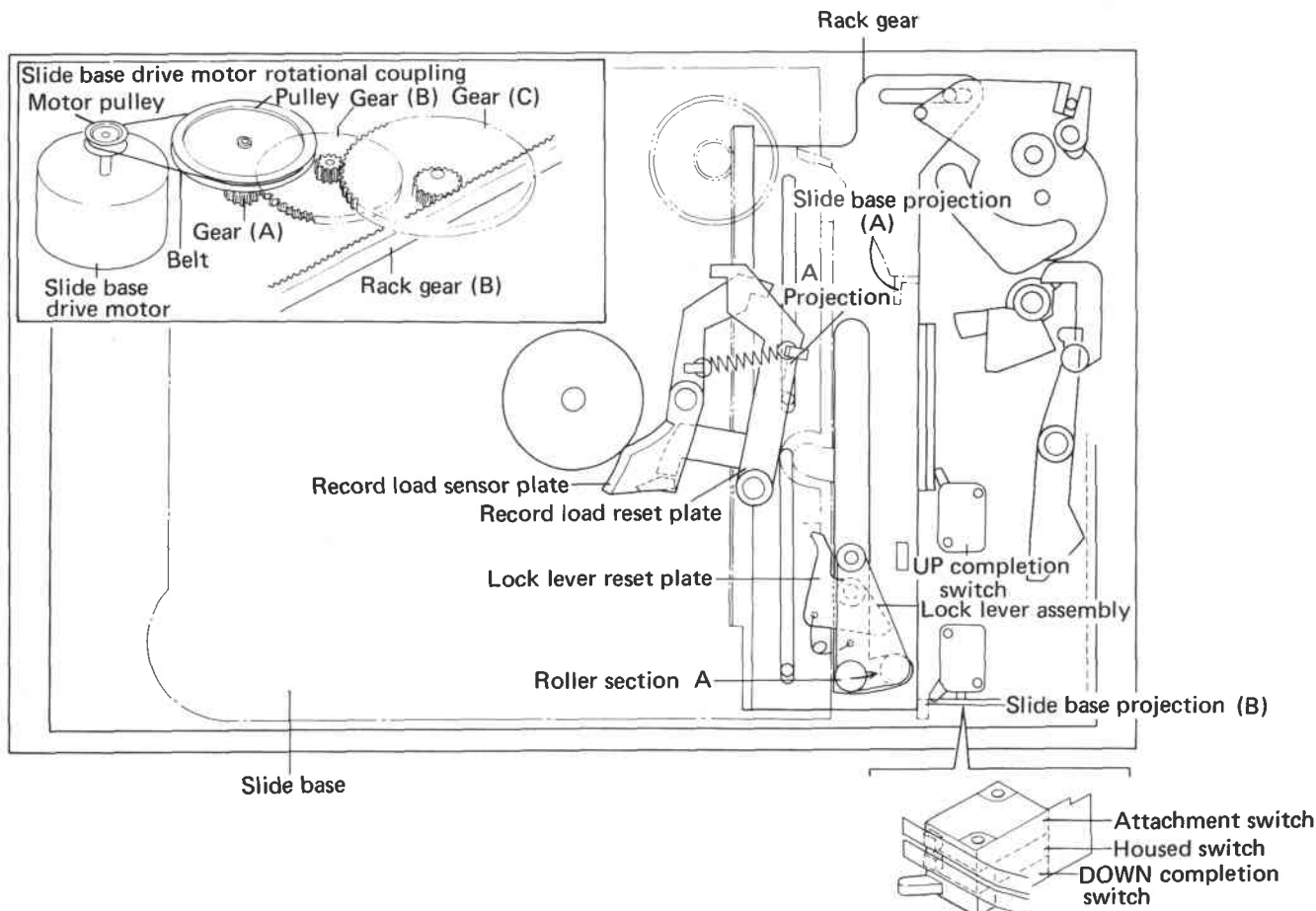

Fig. 6-1 Mechanism in the housed position

starting playback. At the same time, the rack gear turns the DOWN completion switch ON and stops the slide base drive motor (refer to the circuit description).

- At this time, the lock lever reset plate is pressed by the projection on the rack gear, transmitting rotational force to the lock lever assembly to release it from the slide base. In this case, since the rack gear is in an out position, the roller contacts the elongated hole section of the rack gear and stops.

■ Index Cam Assembly Retreat

When a 30cm record disc is played back, the roller section of the index cam assembly cannot be allowed to contact the record disc. The following steps explain the retreat of the index cam assembly during playback.

- As explained in the section on slide base operation until playback, the slide base moves toward the housed position while the turntable is rotating. The slide base cover also moves in conjunction with this operation.
- As this occurs, the side surface of the right hand side of the slide base cover moves the reset lever and sets it in a retreat position in relation to the index cam assembly.
- In conjunction with the forward movement of the rack, the index cam assembly is pushed to a retreat position by the driving plate index cam reset pin.

■ Mechanism Operation Accompanying Arm Elevation Switch UP/DOWN Settings

Refer to the circuit description during the explanation of this operation.

- The positioning of the switches for the various slide base positions is as shown in the table below.

Slide base position Switch	Housed position	Record-load position	Playback position	Record-load position
Housed switch	① ON	OFF	OFF	OFF
Attachment switch	ON	② OFF	ON	OFF
UP completion switch	ON	ON	OFF	ON
DOWN completion switch	OFF	OFF	ON	OFF

NOTES:

- ON indicates switch depressed.
- OFF indicates switch released.

- Projection (A) of the slide base presses the upper side actuator (leaf spring) ON.
- Projection (B) of the slide base presses the lower side actuator (leaf spring) OFF.

- In accordance with the various switch positions shown in the table, the arm elevation switch operation, through the instructions from the PL-X50 control IC, specifies the forward or reverse rotation of the slide base drive motor, and through the movement of the rack gear, travels up and down the slope of the driving plate to raise or lower the tonearm.
- Also, the operation of the arm elevation switch is dependent on whether the slide base is in the housed position or record-load position.
- At the playback position, the UP or DOWN operation is shown in Fig. 6-4. When the UP completion switch is ON, and the DOWN completion switch is OFF, elevation is in an UP status. In this status, when the arm elevation switch is pressed DOWN, the slide base drive motor rotates in a forward direction.

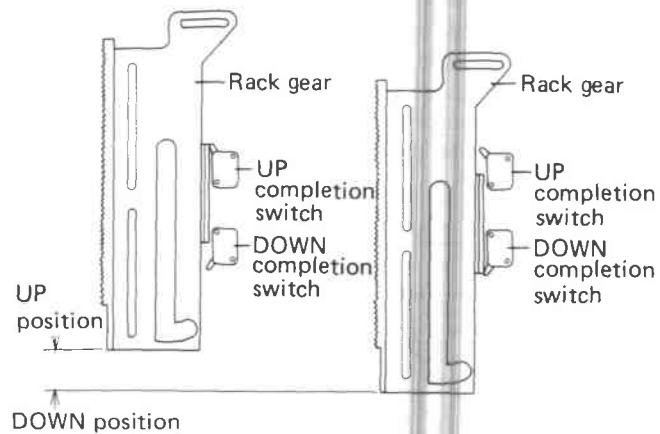

Fig. 6-4 Rack gear position

- As the rack gear moves in a forward direction, the slope section of the driving plate lowers the elevation. This causes the UP completion switch to go OFF, and the DOWN completion switch to go ON, turning the slide base drive motor OFF.
- When the UP completion switch is in an OFF position and the DOWN completion switch is ON, if the arm elevation switch is pressed to the UP position the slide base drive motor will rotate in reverse.
- The rack gear then moves in a backward direction causing the driving plate to rotate in a reverse direction and the slope section raises elevation. Then when the UP completion switch goes ON, and the DOWN completion switch goes OFF the slide base drive motor is stopped.

■ **Tone Arm And Slide Base Operation After Completion of Playback**

1. After record playback is completed and the end sensor operates (refer to the circuit description), or if the START/STOP button is depressed during playback, the slide base drive motor rotates in a reverse direction, moving the rack gear back. At the same time, turntable platter rotation stops.
2. Operation thereafter is the reverse procedure of that explained in the tonearm operation section. The arm elevation shaft goes UP, and the driving plate moves the PU plate shaft to return the tonearm to its original position.
3. Also, immediately prior to the driving plate stopping rotating, the lead-in latch contacts the cut-out in the front base and is overted, holding the PU plate shaft.
4. The rack gear, as explained in the tonearm operation section is prevented from moving by the roller section of the lock lever assembly engaging the rack gear detent.
5. When the rack gear can no longer move, the slide base moves outward and projection (A) on the slide base presses the attachment switch actuator, turning it OFF.
6. At the same time, one side of the slide base reset inverts the lock lever reset plate. When this happens, it is possible for the lock lever assembly to rotate CW, however, since it is butted up against the slide base side, the rack is held in a locked position.
7. In this status, if the record disc is changed and the START/STOP button pressed again, the operations as listed in the tonearm operation section are repeated.
8. If a record disc is not loaded on the turntable platter and the START/STOP button is pressed, the slide base drive motor rotates in a forward direction moving the slide base back. At the housed position, projection (B) on the slide base presses the housed switch actuator turning it OFF.
9. Simultaneously, as the slide base moves in a backward direction the projection on the record load sensing reset plate contacts the lock lever reset plate, inverting it in a CW direction. Accomplishing this, the lock lever assembly is forced into the cut-out portion on the side of the rack making it possible to bypass the cut-out section on the slide base and travel to the housed position.
10. Here the slide base driving motor stops rotating, completing the playback mode of operation. Closing the door will cut off the power switch.

■ **Tone Arm Operation**

1. The driving plate is installed back of the rack gear. Forward movement of the rack gear allows the driving plate to start rotating.
2. The PU plate shaft is scissored between the driving plate and lead-in latch. The PU plate shaft is fixed to the PU plate, and the PU plate is attached to the tonearm pivot by screws.
3. Forward movement of the rack gear causes the driving plate to rotate, this in turn rotating the tonearm (bringing the tonearm to the playback position).

PU plate rotates, the projection on the PU plate bypasses the large lobe and continues rotating until it contacts the small lobe (for 30cm records).

3. When the roller section is not pressed, the plate remains in the back position and the projection on the PU plate strikes the large lobe (17cm records).

4. As the driving plate rotates, the record size is sensed by the record disc size sensing mechanism, and the projection on the PU plate strikes the index cam assembly.
5. The PU plate shaft is scissored between the driving plate and the lead-in latch. Thus, the PU plate is prevented from moving by the index cam assembly.
6. However, the driving plate continues to rotate, and the PU plate shaft pushes the lead-in latch to the opposite side. This allows the tonearm to come to the playback position. The driving plate continues to rotate, and the arm elevation shaft lowers down the sloped section of the driving plate. The tonearm is thus lowered,

■ **Record Size Sensing Mechanism**

1. Automatic playback of 17cm or 30cm records is possible with the PL-X50. When 30cm records are played, the roller section of the index cam assembly is pressed. The roller section is not pressed when 17cm records are played.
2. Pressing the roller section of the index cam assembly causes the plate attached to the index cam assembly on the opposite side of the roller to be brought to a forward position. Thus, when the

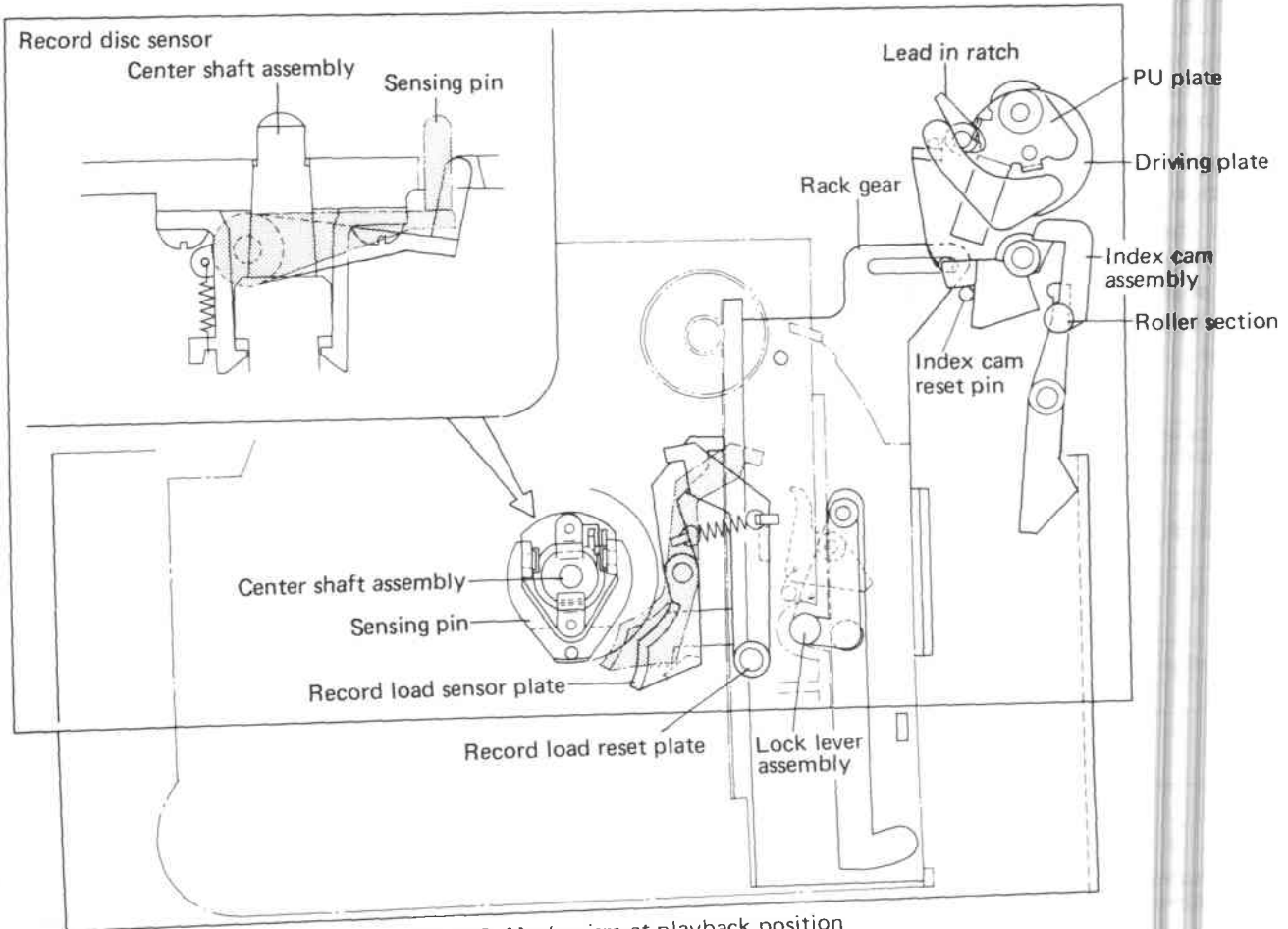

Fig. 6-3 Mechanism at playback position

■ Slide Base Operation Until the Playback Point

1. When the slide base (turntable platter) is in a fully extended status, if a record disc is loaded on the turntable platter, the sensing pin located near the center shaft assembly will be depressed by the weight of the record.
2. When the START/STOP button is depressed again, the turntable platter will start rotating and the slide base will move back.
3. Rotation of the turntable platter causes the sensing pin depressed by the weight of the record to bump the record load sensing disc. In turn, the movement of the record load sensing disc bumps into the record load reset disc and sets it to the side indicating a record is present.
4. A projection is built into the record load reset plate, and as the slide base moves in a backward direction, this projection passes by the left side of the lock lever reset plate.
5. Since the lock lever reset plate stays in a status indicating a record is loaded, it enables the lock lever assembly to rotate toward the slide base side and one of the end rollers is engaged in the rack gear. The disengaged roller on the opposite end is pressed up against the side of the slide base by the force of the spring.
6. The slide base then continues to move further back. Finally, when the slide base is approximately 60mm out from its original position, the roller of the lock lever assembly enters the depression of the slide base and prevents it from moving.
7. When the slide base can no longer move, gear (C) and the rack gear are engaged. Since the rack gear is now released from the lock lever assembly it can move in a forward direction. Also, this position is the playback position for the slide base.

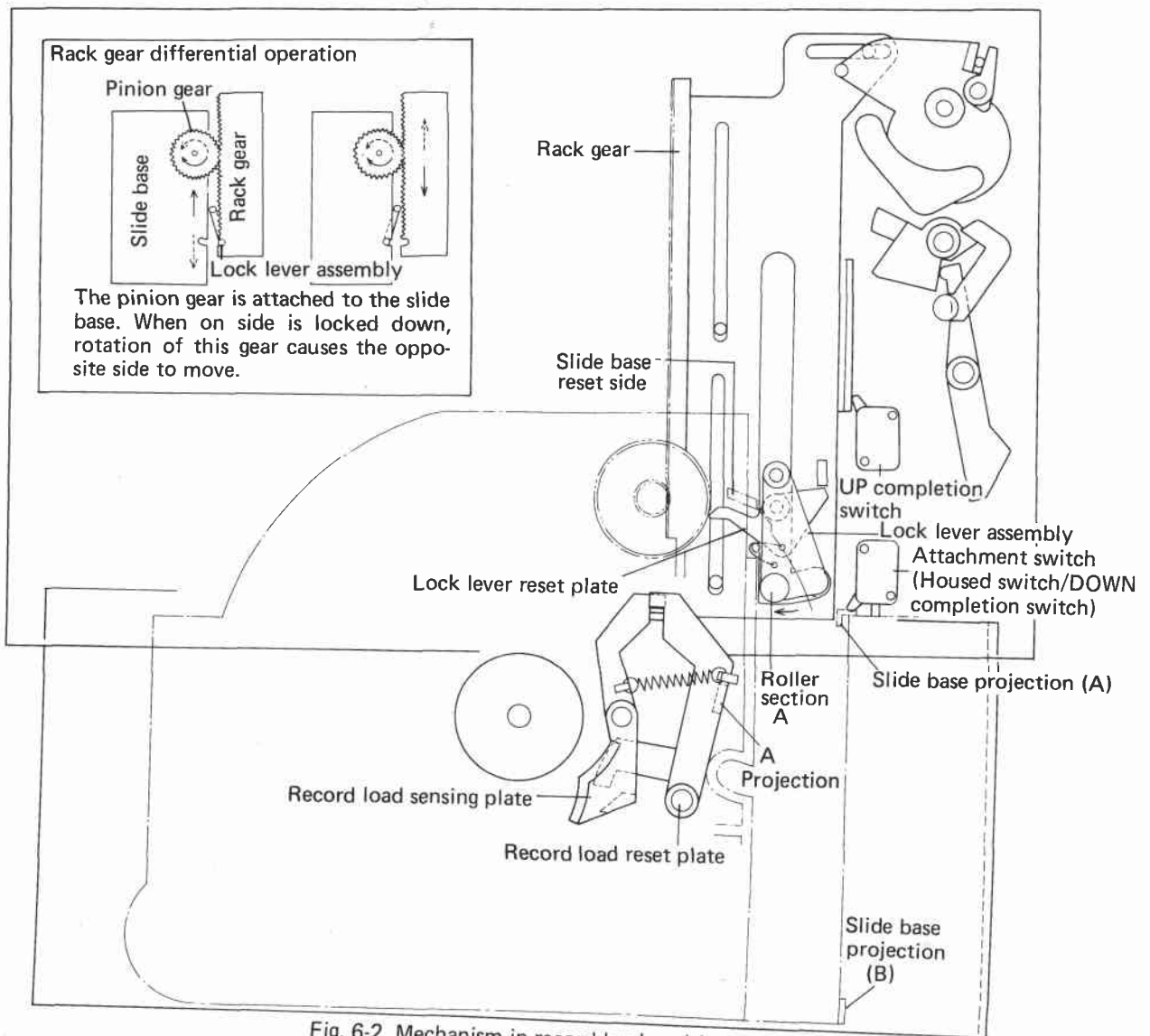
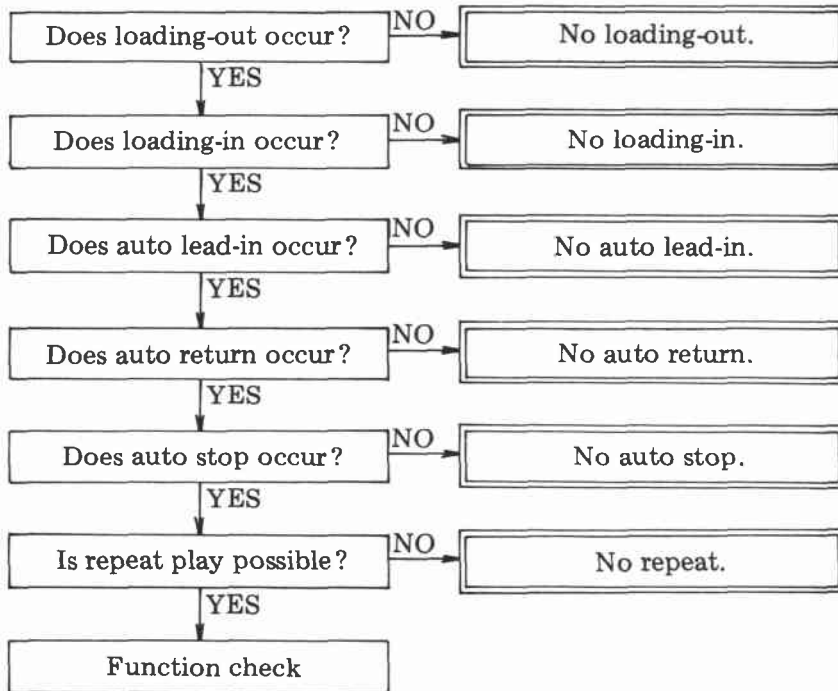

Fig. 6-2 Mechanism in record-load position

## 7. TROUBLESHOOTING

- When making repair to the PL-X50, first isolate the problem area by performing an operational check. After the general malfunction is located, refer to the detailed flowchart for further analysis. Items in the double lined blocks are further detailed later in this section.

### ■ AUTOMATIC OPERATION CHECK



### ■ FUNCTION CHECK

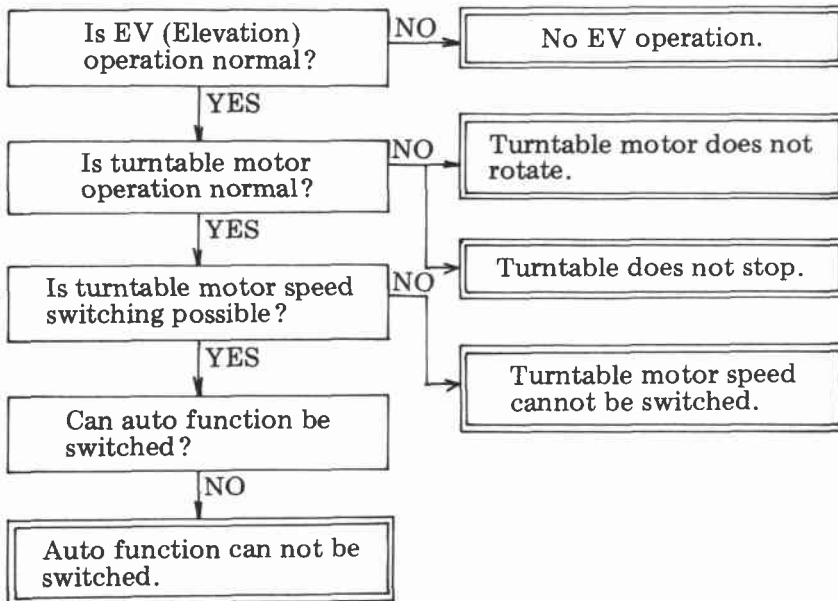

■ NO AUTO LEAD-IN

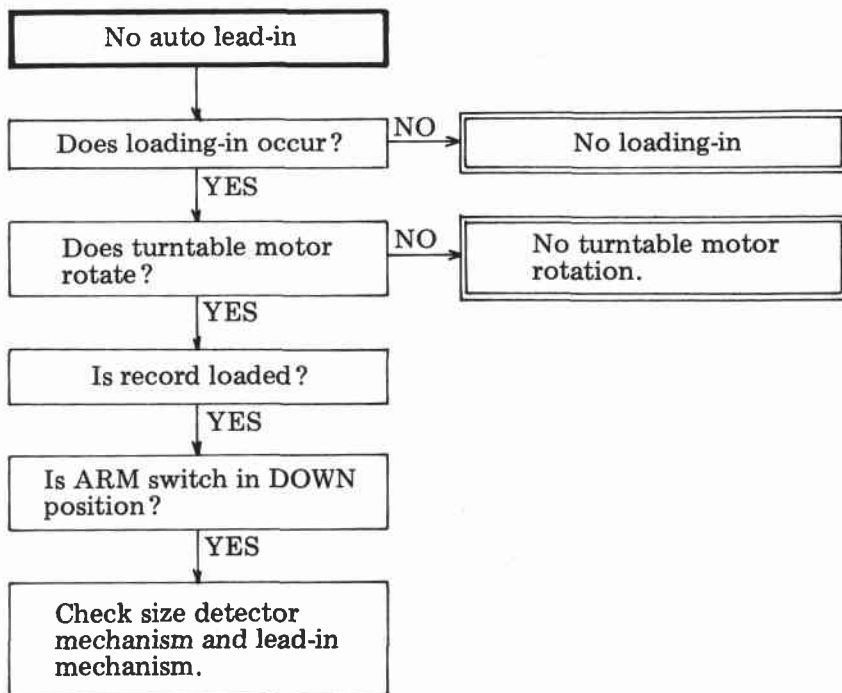

■ TURNTABLE MOTOR WILL NOT STOP

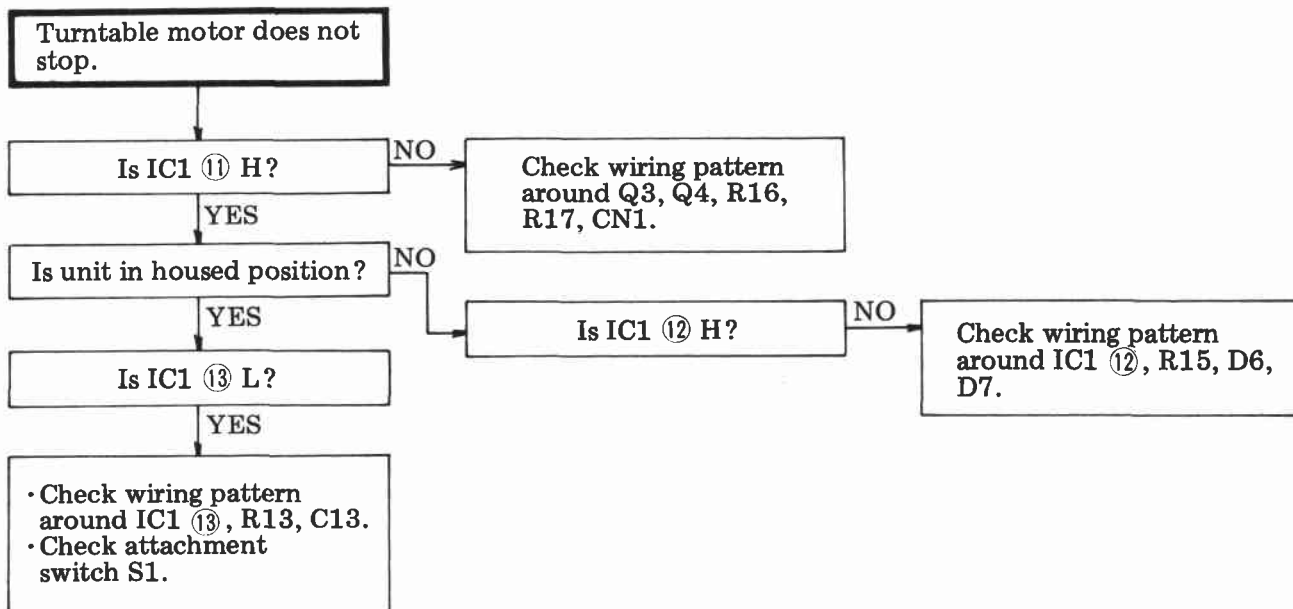

*Note:*  
Perform check at housed position or record load position.

■ NO LOADING-IN

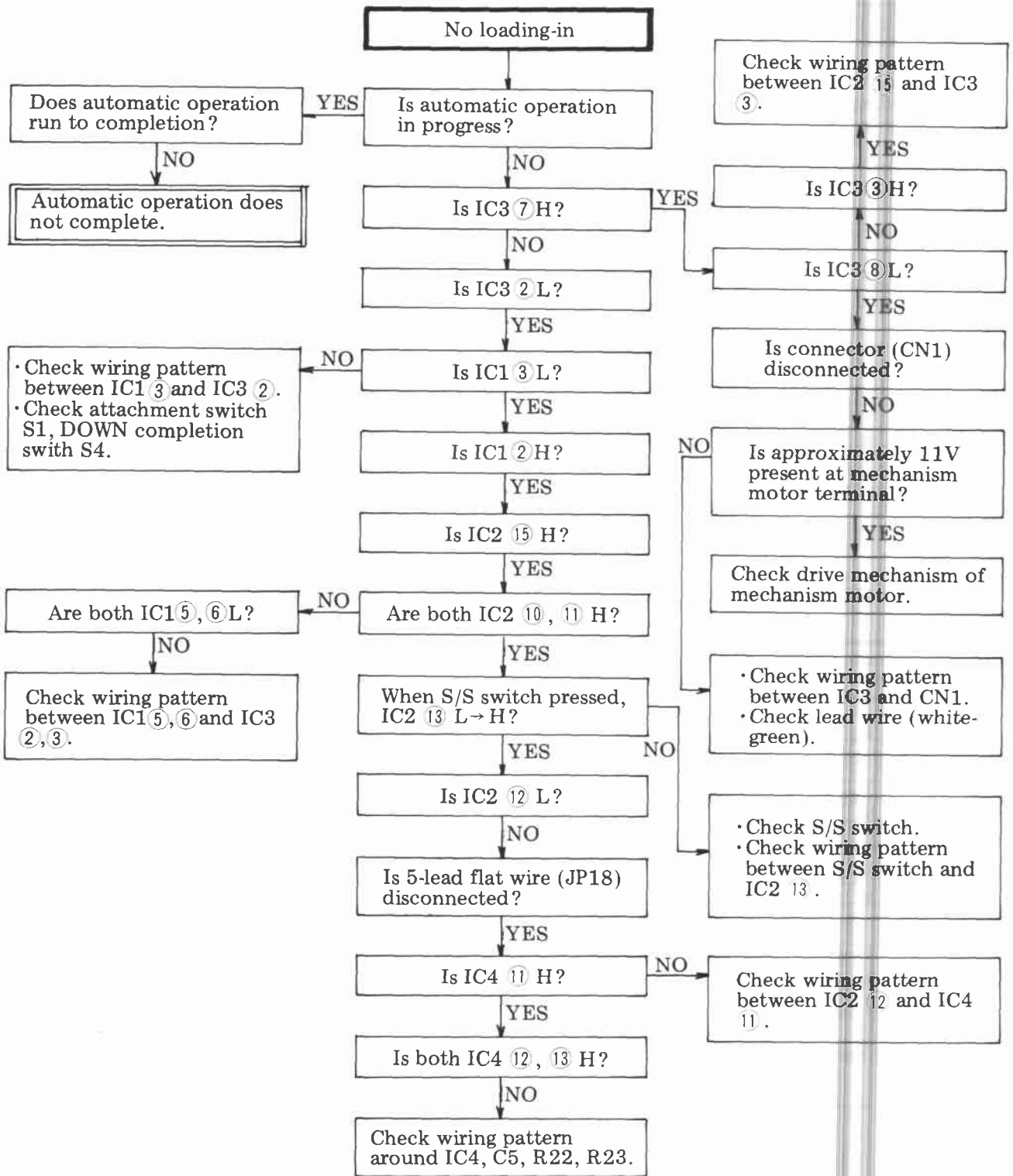



■ NO LOADING OUT—NO AUTO STOP

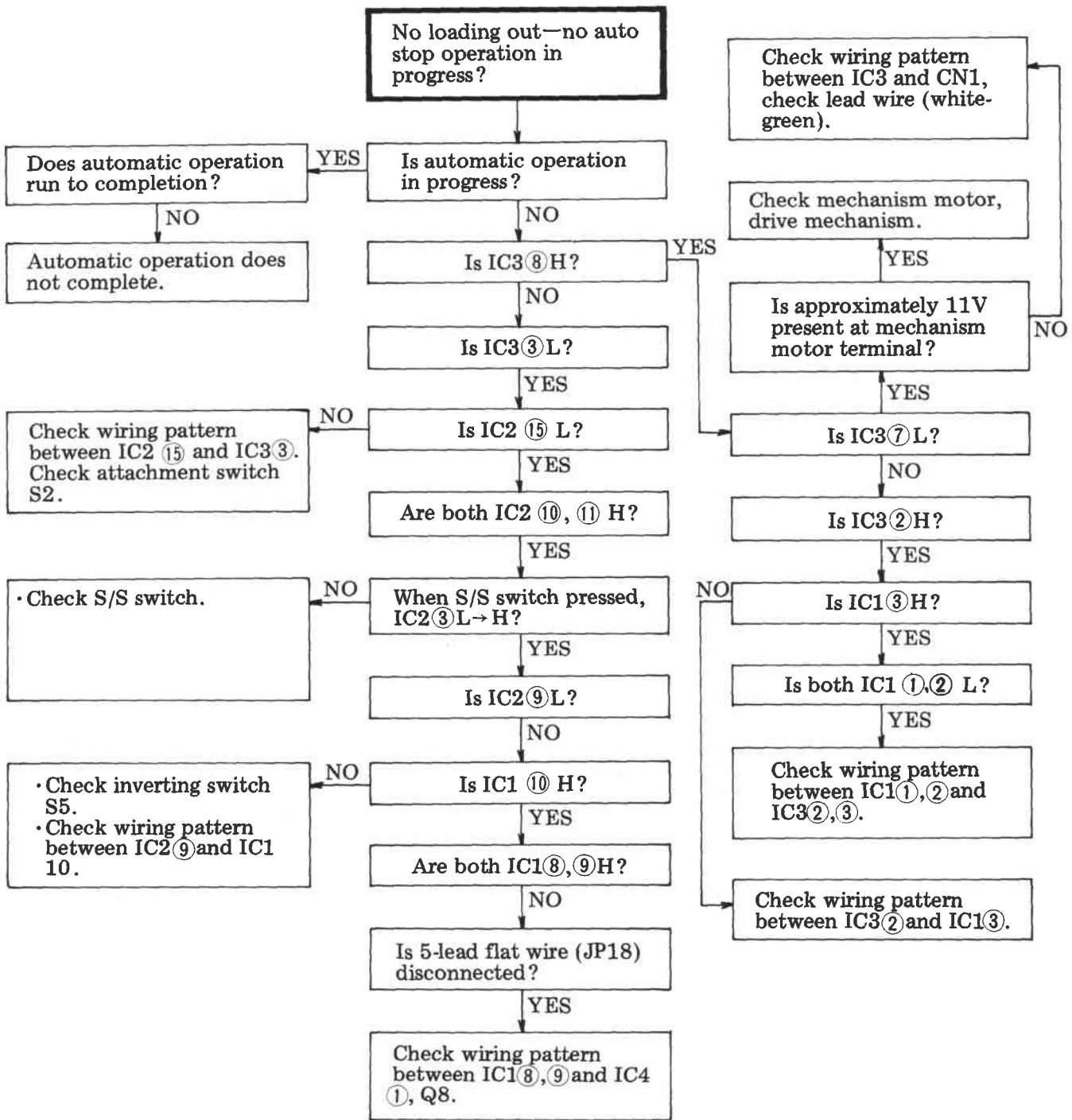

Note:  
S/S abbreviation for START/STOP switch.

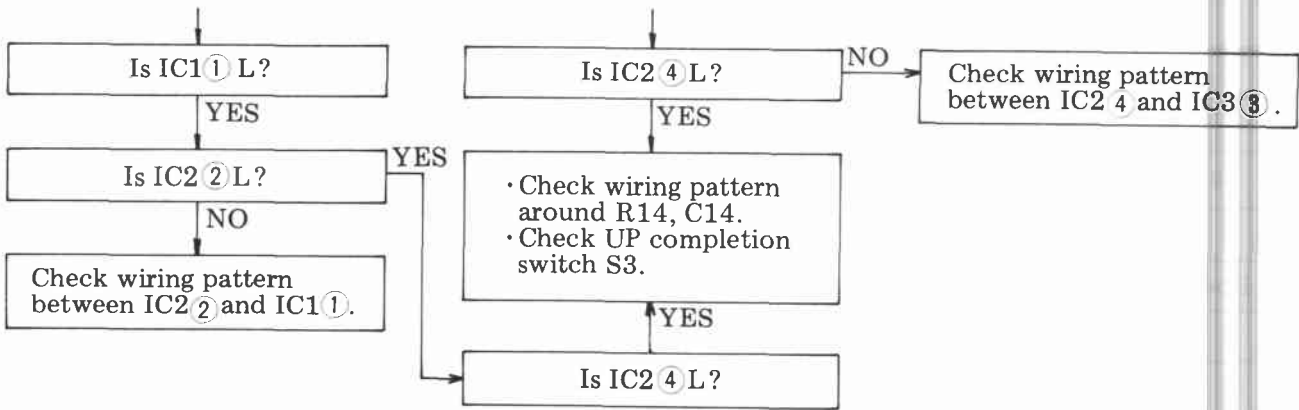

■ AUTO OPERATION WILL NOT COMPLETE

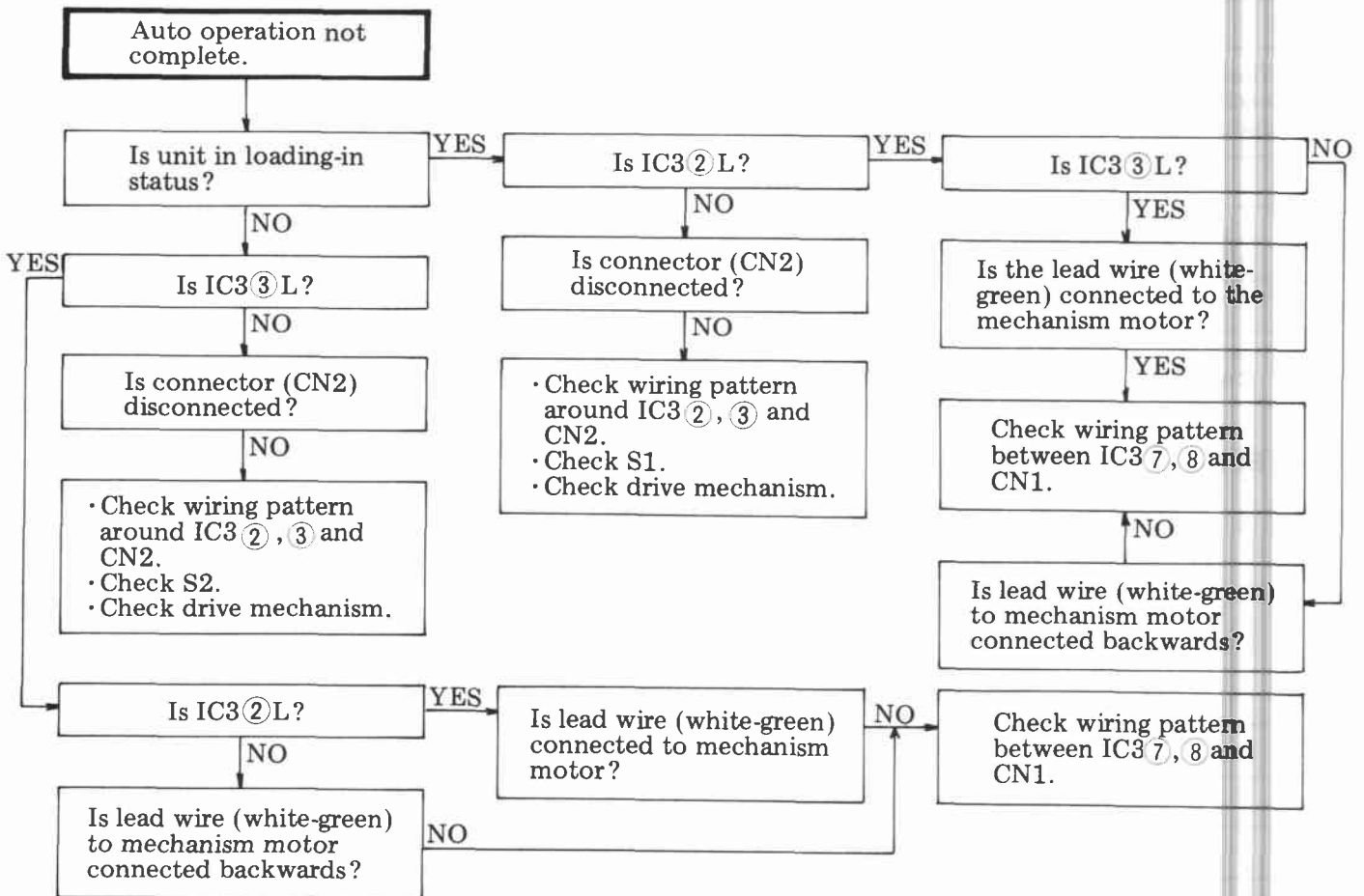

■ TURNTABLE MOTOR DOES NOT ROTATE

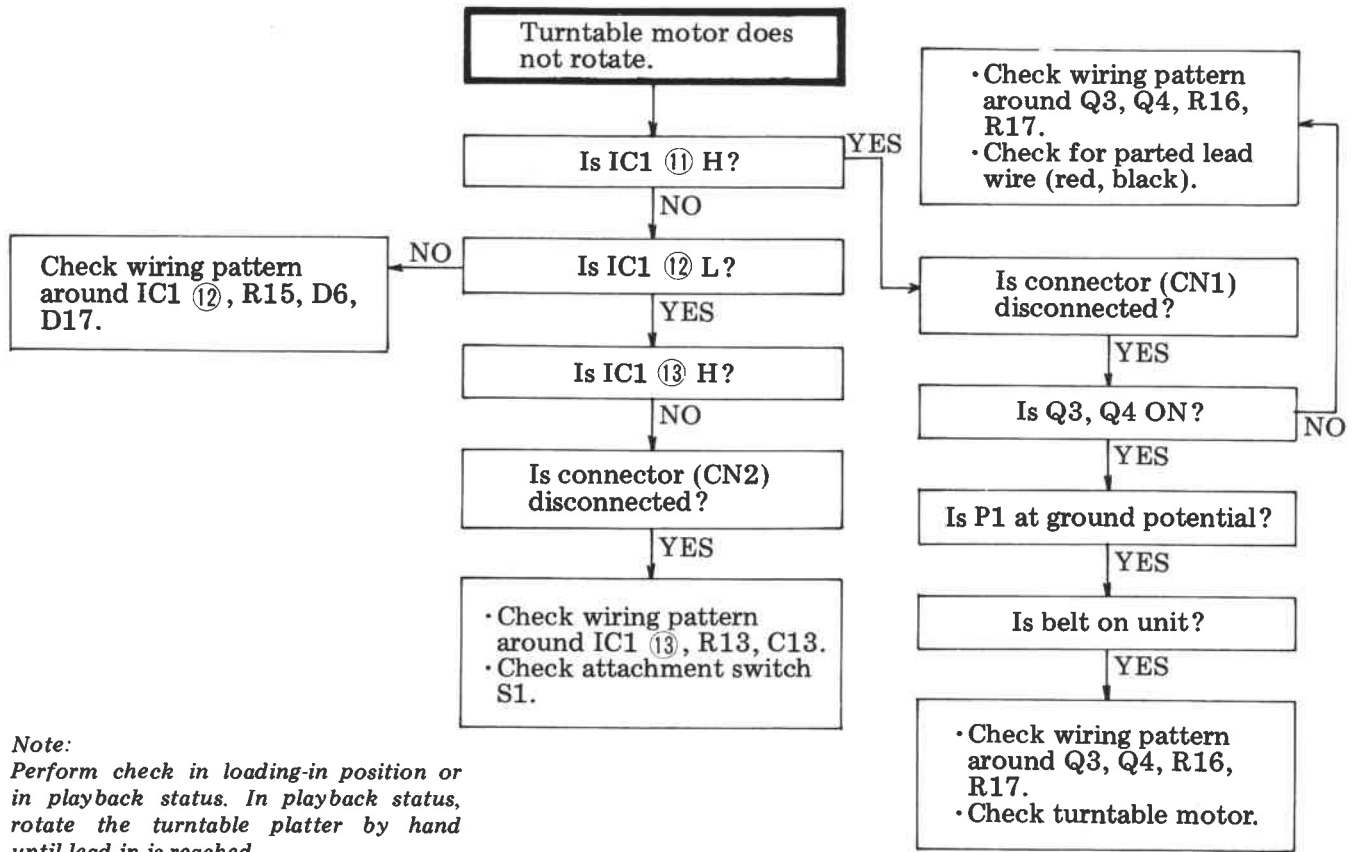

■ AUTO FUNCTION WILL NOT SWITCH

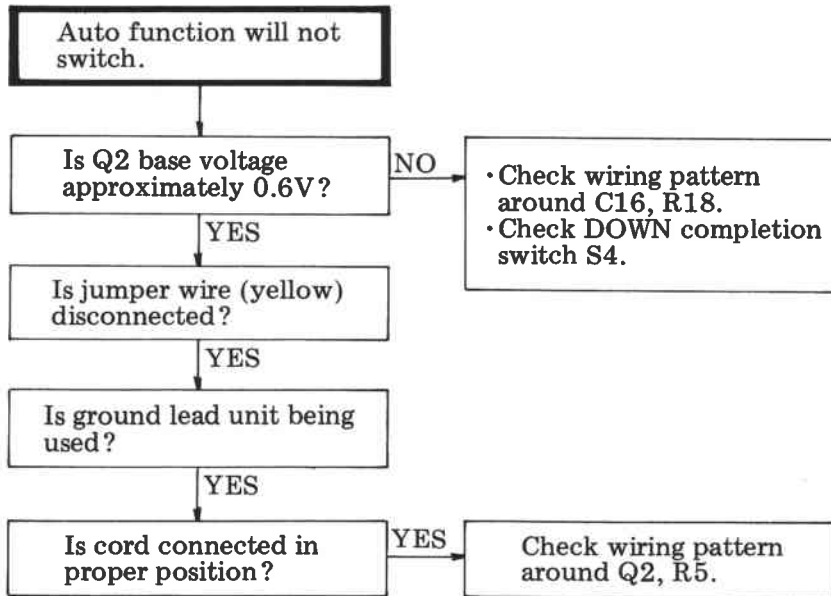

■ NO AUTO RETURN

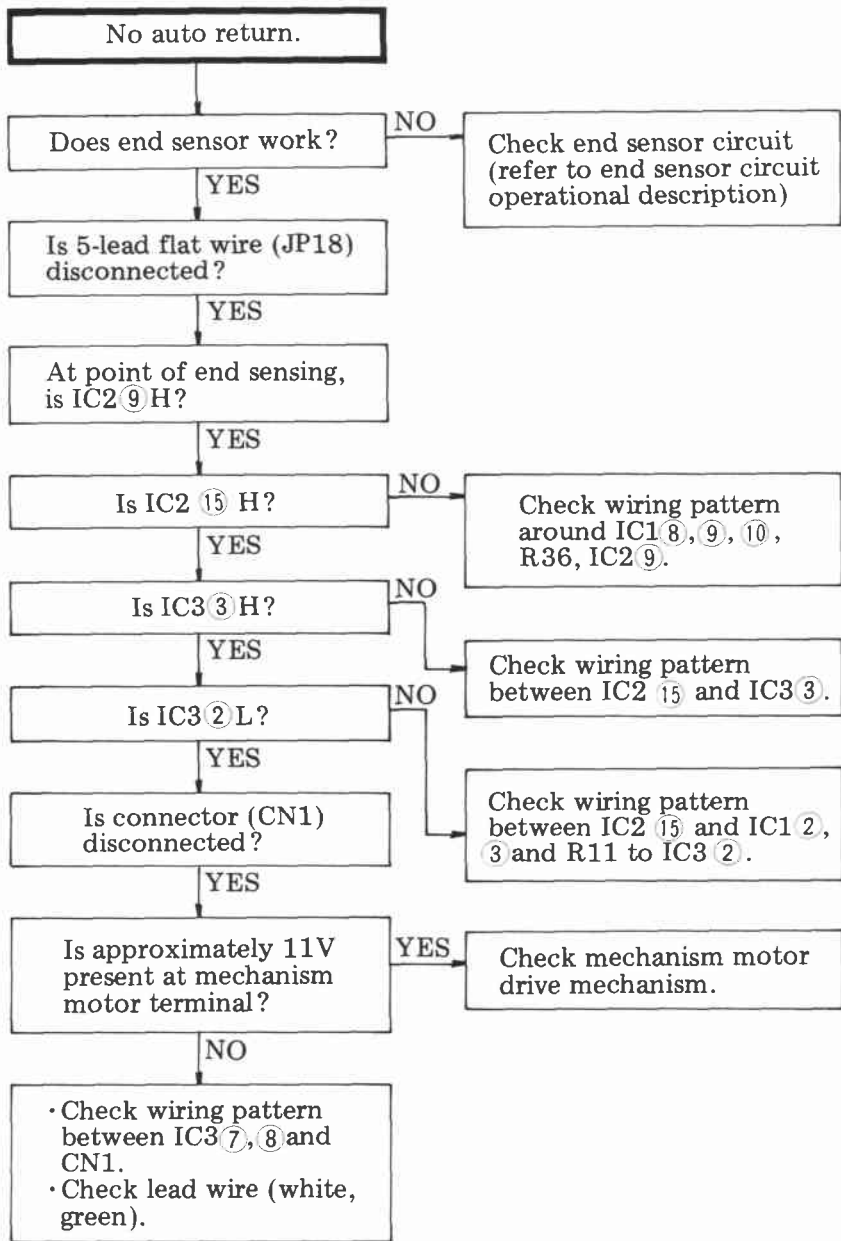

■ TURNTABLE MOTOR SPEED WILL NOT SWITCH

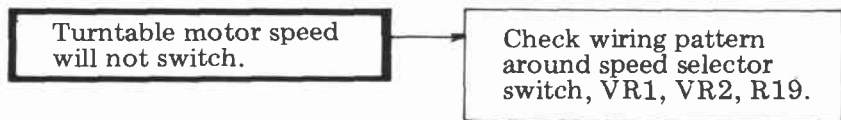

■ NO REPEAT PLAY

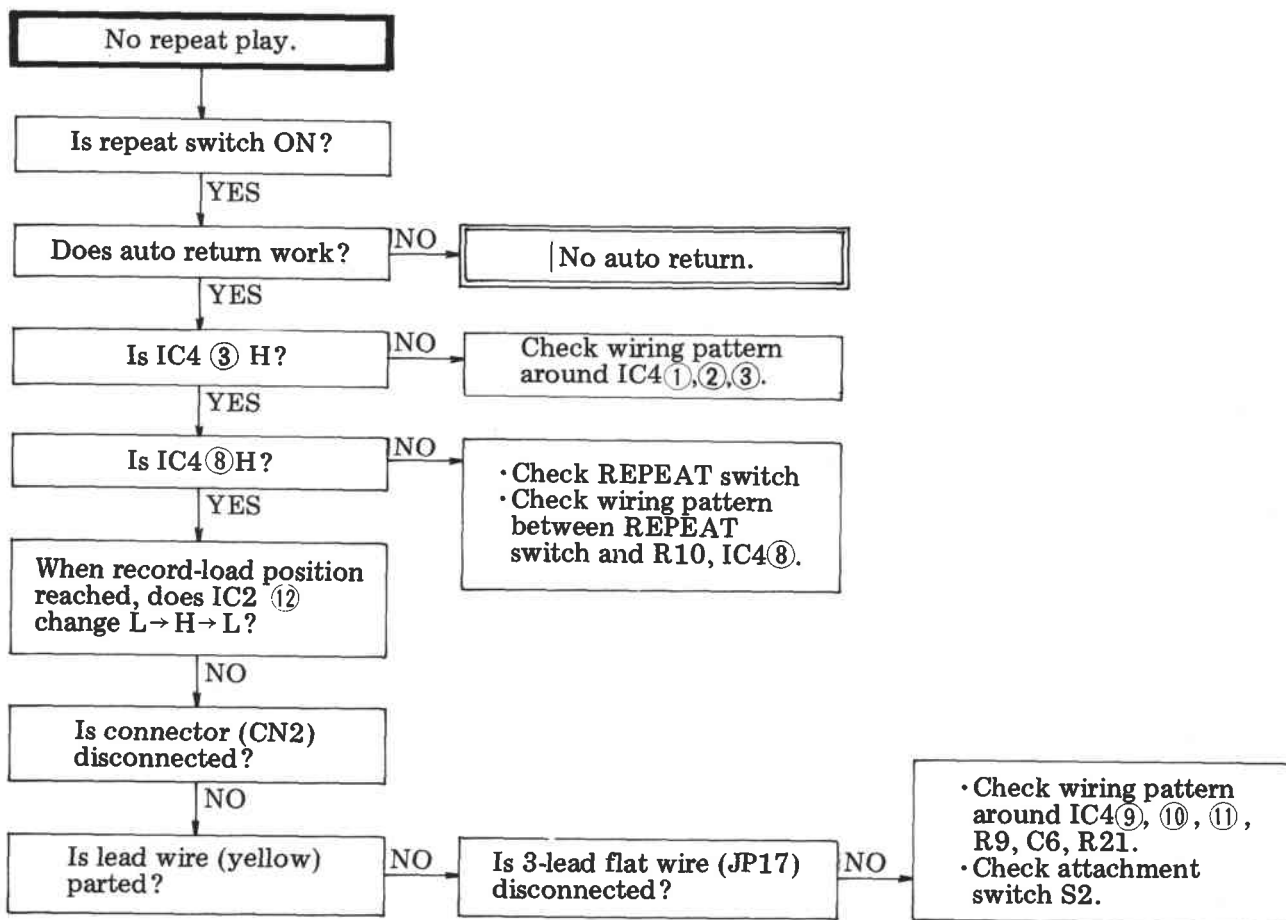

■ NO ELEVATION OPERATION

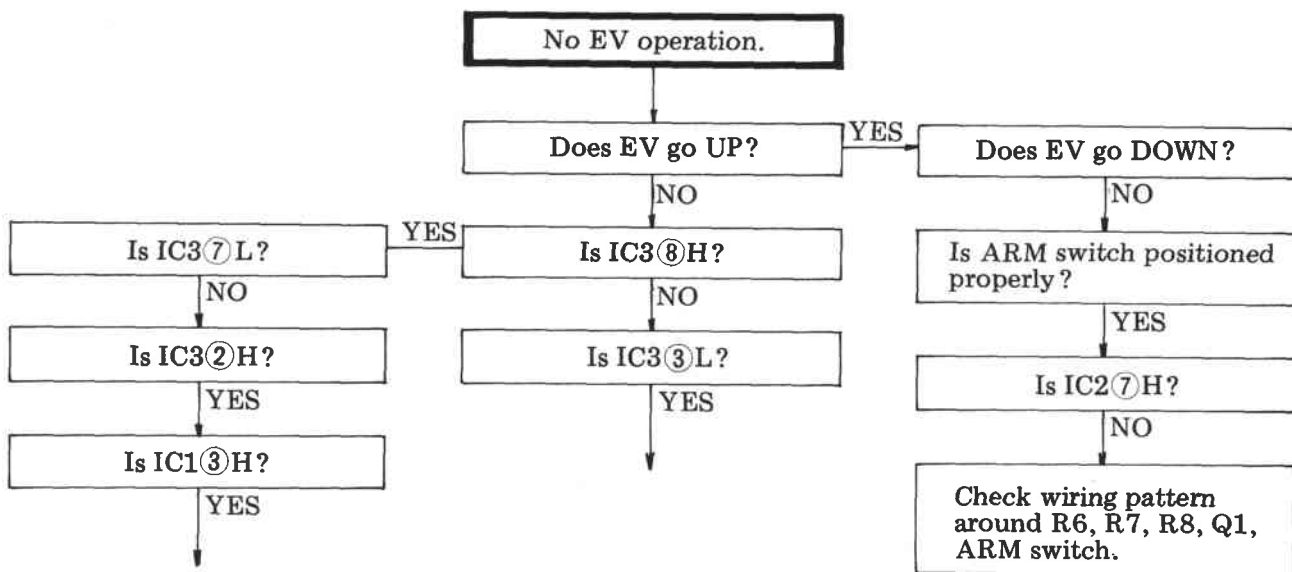

— Continued to page 36 —

# 9. P.C. BOARD CONNECTION DIAGRAM

A

B

C

D

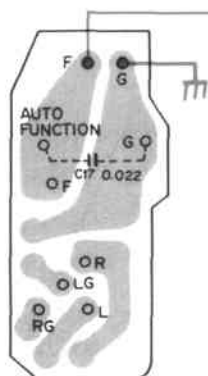

PIN JACK Ass'y  
XWX-070

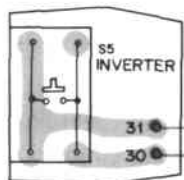

SWITCH Ass'y (B)  
XWS-013

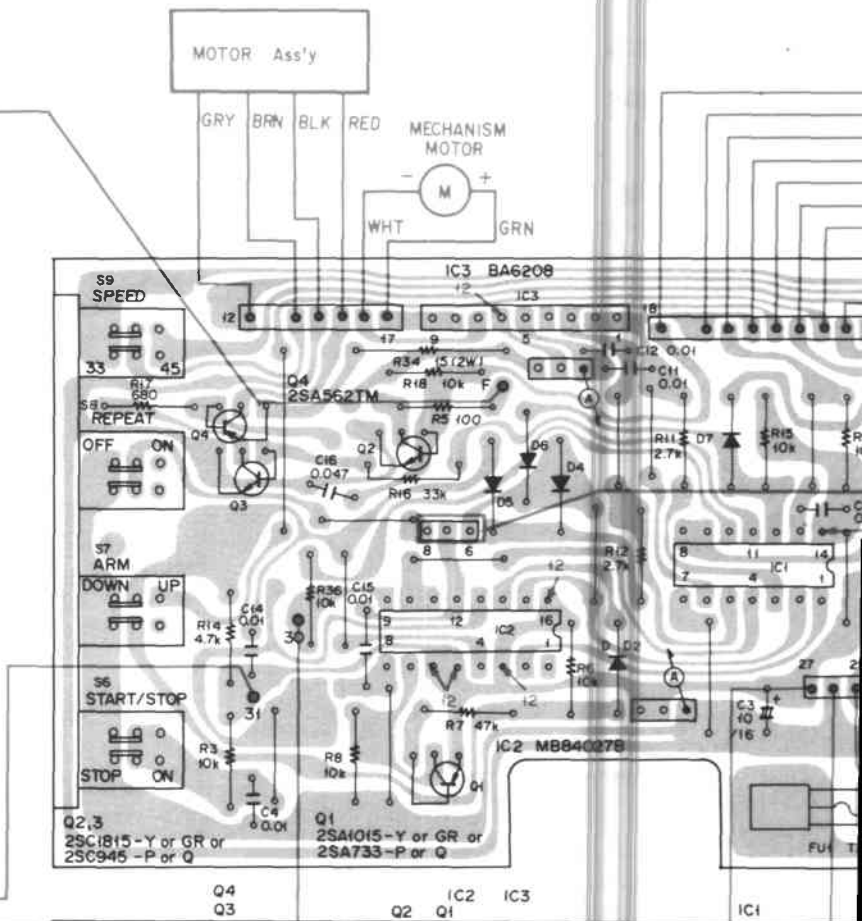

CONTROL Ass'y  
XWM-073

IC Ass'y  
XWX-069

WITCH Ass'y (A)  
XWS-012

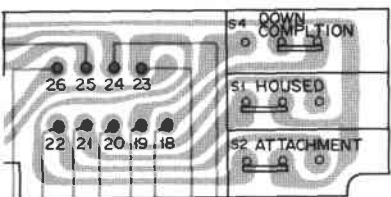

DETECTOR Ass'y  
XWX-068

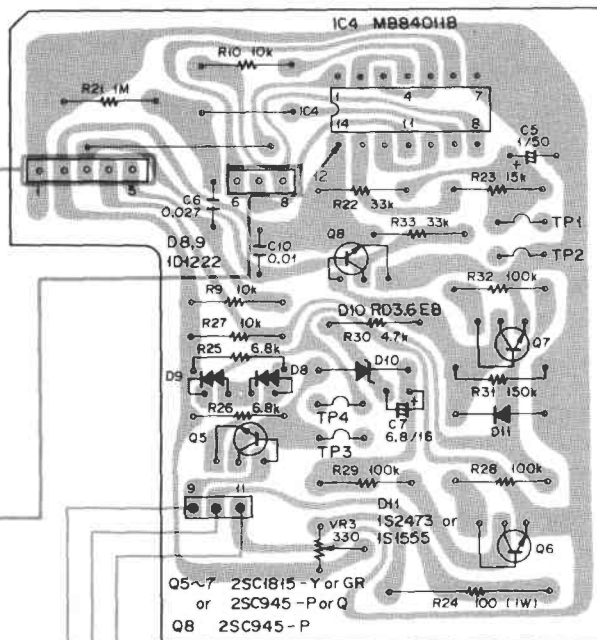

Q5 Q8 IC4 Q7  
VR3 Q6

SENER Ass'y  
XWX-071

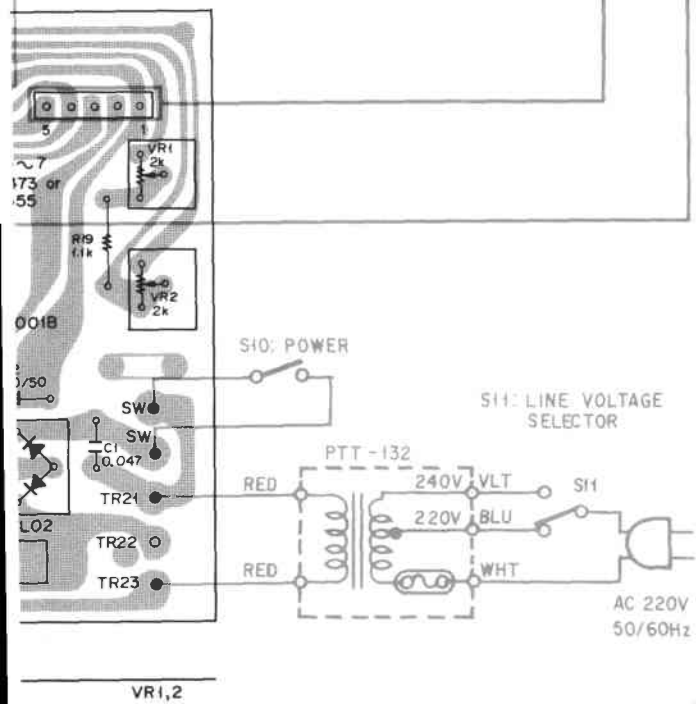
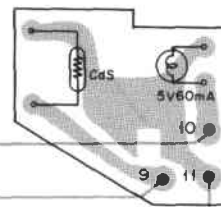

A

B

C

D

## 8. ELECTRICAL PARTS LIST

### NOTES:

- When ordering resistors, first convert resistance values into code form as shown in the following examples.

Ex. 1 When there are 2 effective digits (any digit apart from 0), such as 560 ohm and 47k ohm (tolerance is shown by J = 5%, and K = 10%).

560Ω	56 × 10 <sup>1</sup>	561	RD¼PS	561J
47kΩ	47 × 10 <sup>3</sup>	473	RD¼PS	473J
0.5Ω	0R5		RN2H	05K
1Ω	010		RS1P	010K

Ex. 2 When there are 3 effective digits (such as in high precision metal film resistors).

5.62kΩ	562 × 100	5621	RN¼SR	5621F
--------	-----------	------	-------	-------

- The **3** mark found on some component parts indicates the importance of the safety factor of the part. Therefore, when replacing, be sure to use parts of identical designation.
- For your Parts Stock Control, the fast moving items are indicated with the marks **★★** and **★**.  
**★★ GENERALLY MOVES FASTER THAN ★.**  
This classification shall be adjusted by each distributor because it depends on model number, temperature, humidity, etc.

### CONTROL ASSEMBLY (XWM-073)

#### CAPACITORS

Mark	Part No.	Symbol & Description
	CKDYF 103Z 50	C4, C11-C15
	CEA 471M 50L	C2
	CEA 100M 16L	C3
	(CEA 100M 25L)	
	CKDYF 473Z 50	C1, C16
	CKDYF 223Z 50	C17

#### RESISTORS

Note: When ordering resistors, convert the resistance value into code form, and then rewrite the part no. as before.

Mark	Part No.	Symbol & Description
★	PCP-067 (PCP-068)	VR1, VR2 Semi-fixed
	RD¼PM □□□ J	R3, R5-R8, R11-R19, R35-R37
	RS2HSBF220JL	R34

#### SEMICONDUCTORS

Mark	Part No.	Symbol & Description
★★	MB84001B (TC4001BP)	IC1
★★	MB84027B (TC4027BP)	IC2
★★	BA6208	IC3
★★	2SA1015 (2SA733)	Q1
★★	2SC1815 (2SC945)	Q2, Q3
★★	2SA562TM	Q4
★	WL02	D1
★	1S2473 (1S1555)	D2, D4-D7

### SWITCH ASSEMBLY (B) (XWS-013)

Mark	Part No.	Symbol & Description
★★	PSG-025	S5 Tact switch

#### SWITCH

Mark	Part No.	Symbol & Description
★★	PSG-034	Function switch

#### FUSE

Mark	Part No.	Symbol & Description
▲★★	KEK-008	Fuse T315mA

### IC Assembly (XWX-069)

Mark	Part No.	Symbol & Description
★★	μPC78M12H	IC5

### PIN JACK ASSEMBLY (XWX-070)

Mark	Part No.	Symbol & Description
	PKB-002	Pin jack

### SENSOR ASSEMBLY (XWX-071)

Mark	Part No.	Symbol & Description
	PDE-104	Connector
★	PCX-031	Cds
★★	PEL-048	Lamp
	PNX-302	Lamp holder



## SENSING ASSEMBLY (XWX-068)

## CAPACITORS

Mark	Part No.	Symbol & Description
	CEA 1R0M 50L	C5
	CQMA 273K 50	C6
	CSZA 6R8K 16	C7
	CKDYF 103Z 50	C10

## RESISTORS

*Note: When ordering resistors, convert the resistance value into code form, and then rewrite the part no. as before.*

Mark	Part No.	Symbol & Description
★	PCP-044	VR3 Semi-fixed
	RD¼PM □□□ J	R9, R10, R21, R22, R23, R25-R30, R32, R33
	RN¼PR 1503F	R31
	RS1PF 101J	R24

## SEMICONDUCTORS

Mark	Part No.	Symbol & Description
★★	MB84011B (TC4011BP)	IC4
★★	2SC1815 (2SC945)	Q5-Q7
★★	2SC945	Q8
★	VD1222	D8, D9
★	RD3.6EB	D10
★	1S2473 (1S1555)	D11

## SWITCH ASSEMBLY (A) (XWS-012)

Mark	Part No.	Symbol & Description
★★	PSH-005	S1, S2 Switch
★★	PSH-006	S3, S4 Switch
	PDE-105	Connector assembly

# 11. EXPLODED VIEW

## 11.1 EXTERIOR

A

B

C

D

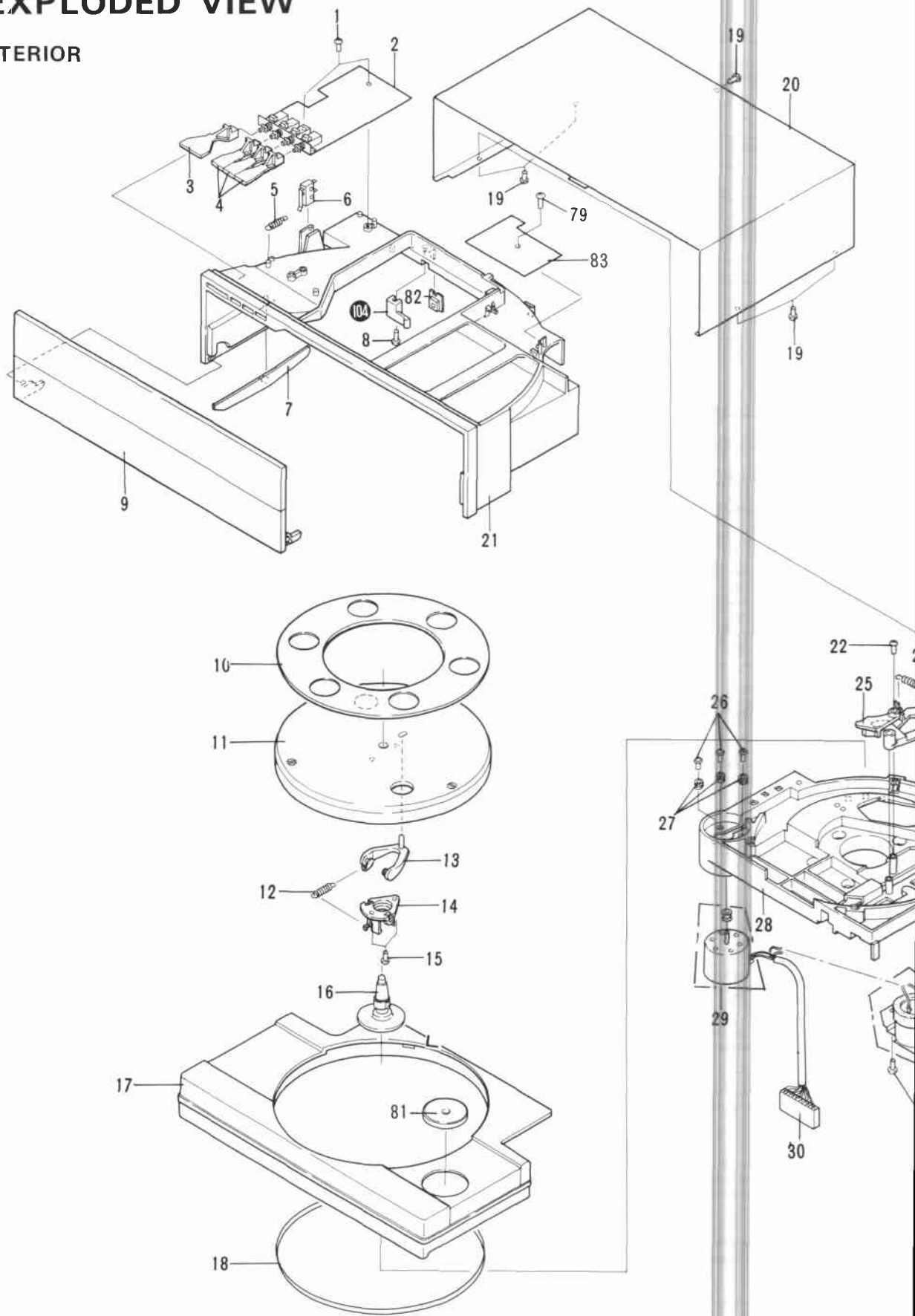

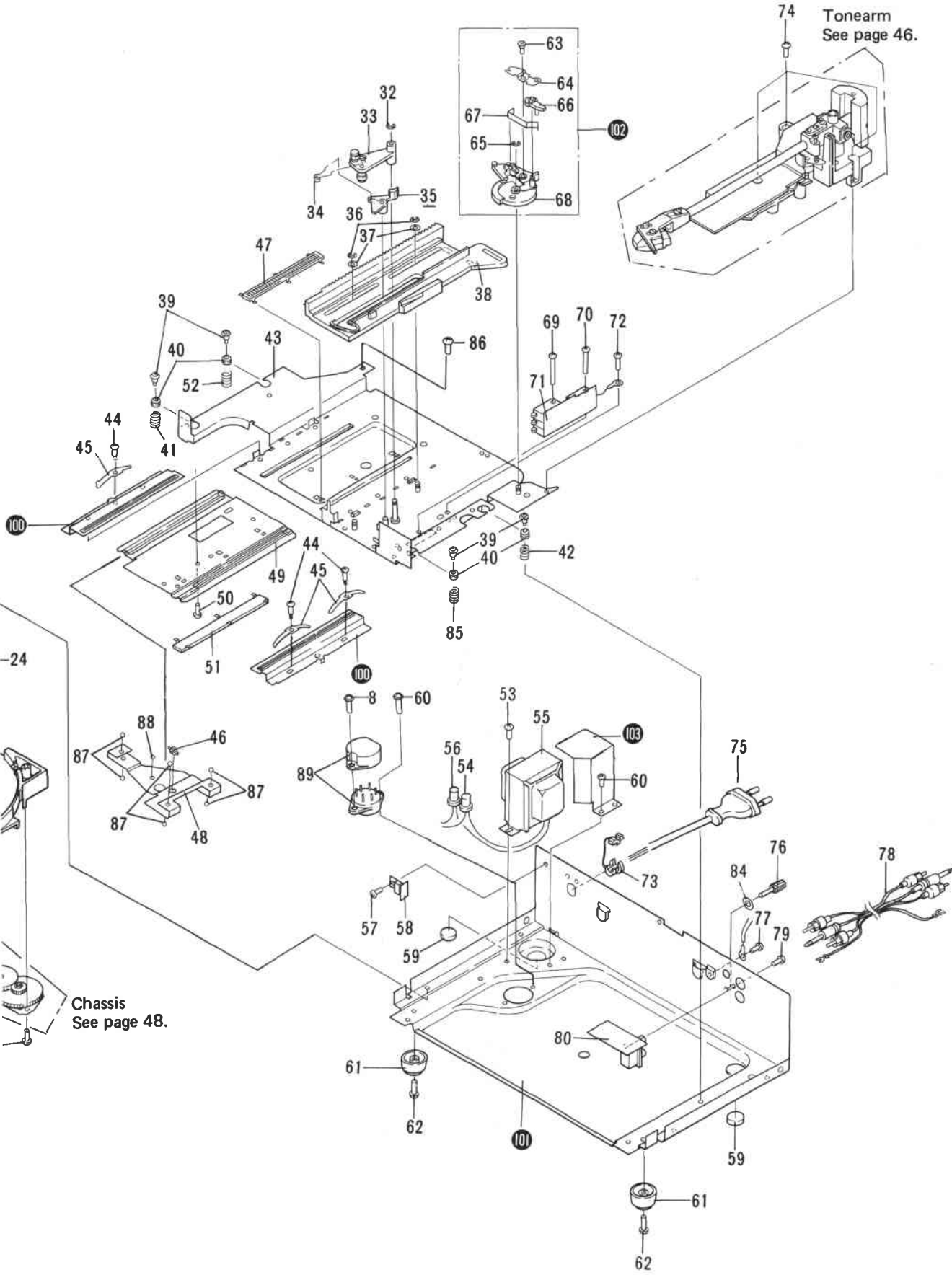

A

B

C

D

**NOTE:**

The indicated semiconductors are representative ones only. Other alternative semiconductors may be used and are listed in the parts list.

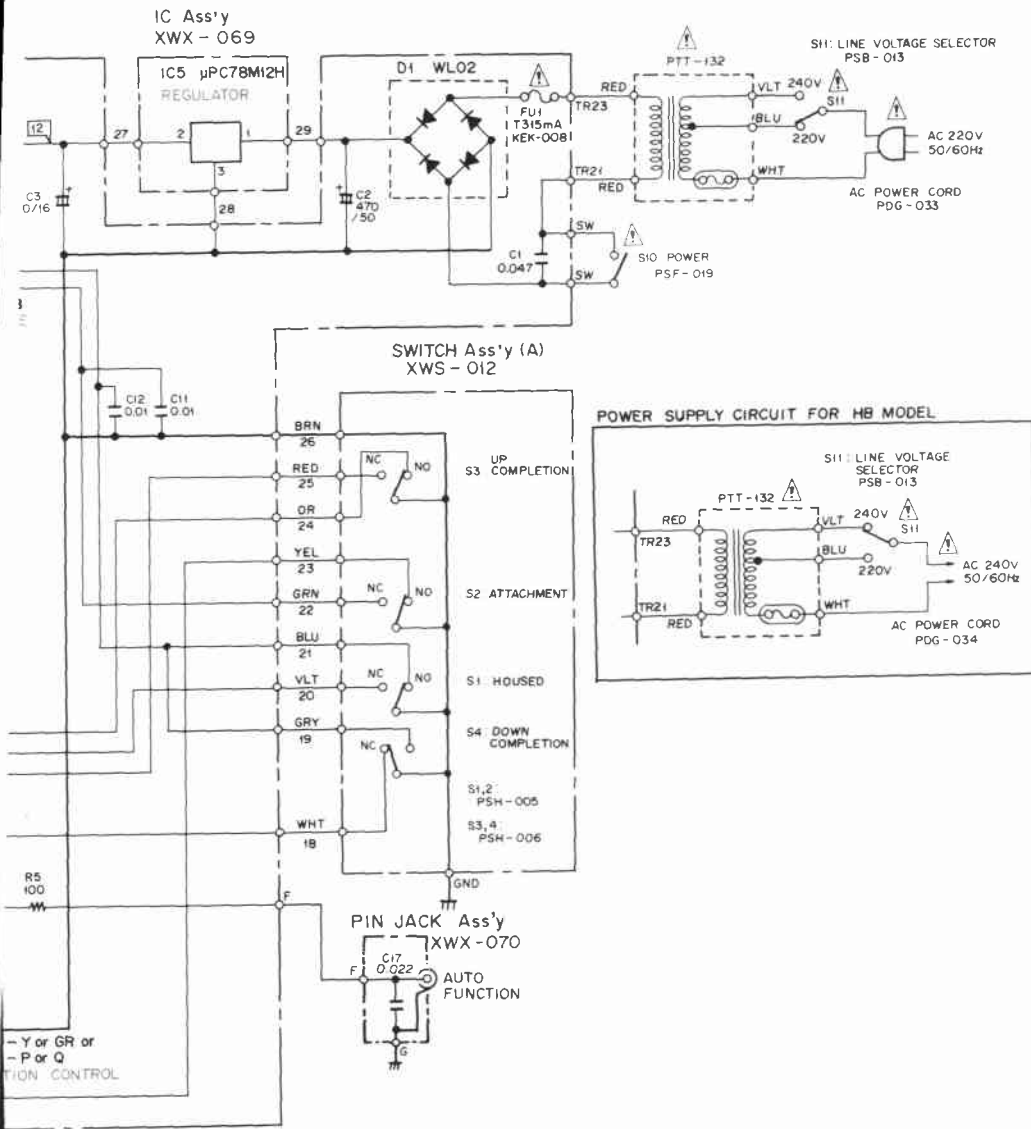

**1. RESISTORS:**

Indicated in  $\Omega$ ,  $\frac{1}{2}W$ ,  $\pm 5\%$  tolerance unless otherwise noted k : k $\Omega$ , M : M $\Omega$ , (F) :  $\pm 1\%$ , (G) :  $\pm 2\%$ , (K) :  $\pm 10\%$ , (M) :  $\pm 20\%$  tolerance

**2. CAPACITORS:**

Indicated in capacity ( $\mu F$ )/voltage (V) unless otherwise noted p : pF Indication without voltage is 50V except electrolytic capacitor.

**3. VOLTAGE, CURRENT:**

$\square$  : DC voltage (V) at no input signal  
 $\leftarrow$  mA : DC current at no input signal

**4. OTHERS:**

$\odot$  : Adjusting point.  
 The  $\triangle$  mark found on some component parts indicates the importance of the safety factor of the part. Therefore, when replacing, be sure to use parts of identical designation.

**SWITCHES:**

- S1 HOUSED ON - OFF
- S2 ATTACHMENT ON - OFF
- S3 UP COMPLETION ON - OFF
- S4 DOWN COMPLETION ON - OFF
- S5 INVERTER ON - OFF
- S6 START/STOP ON - OFF
- S7 ARM UP - DOWN
- S8 REPEAT ON - OFF
- S9 SPEED 33 1/3rpm - 45rpm
- S10 POWER ON - OFF
- S11: LINE VOLTAGE SELECTOR 220V - 240V

The underlined indicates the switch position.

A

B

C

D

# 10. SCHEMATIC DIAGRAM

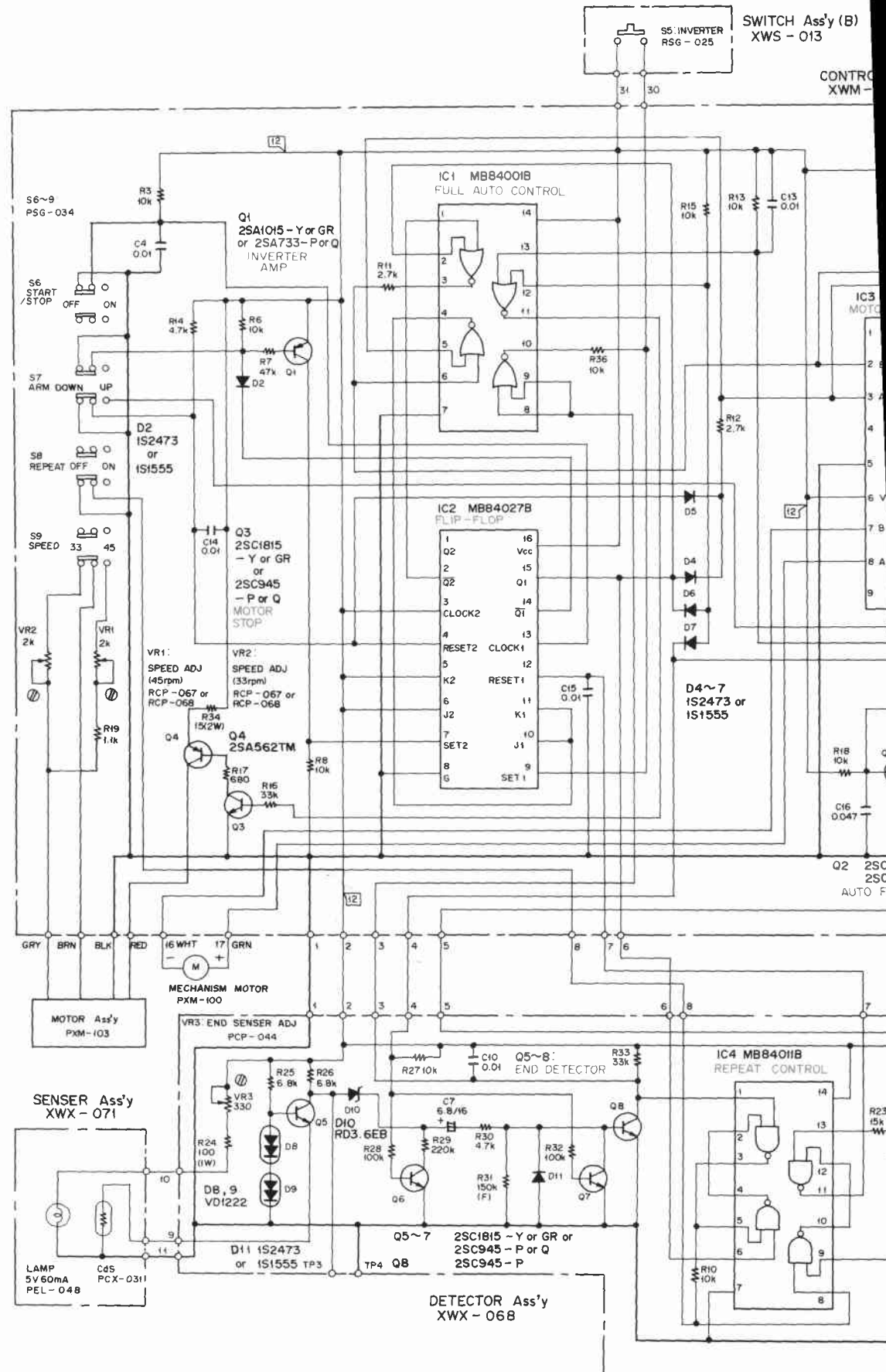

A

B

C

D

1

2

3

# 10. SCHEMATIC DIAGRAM

1

2

3

A

B

C

D

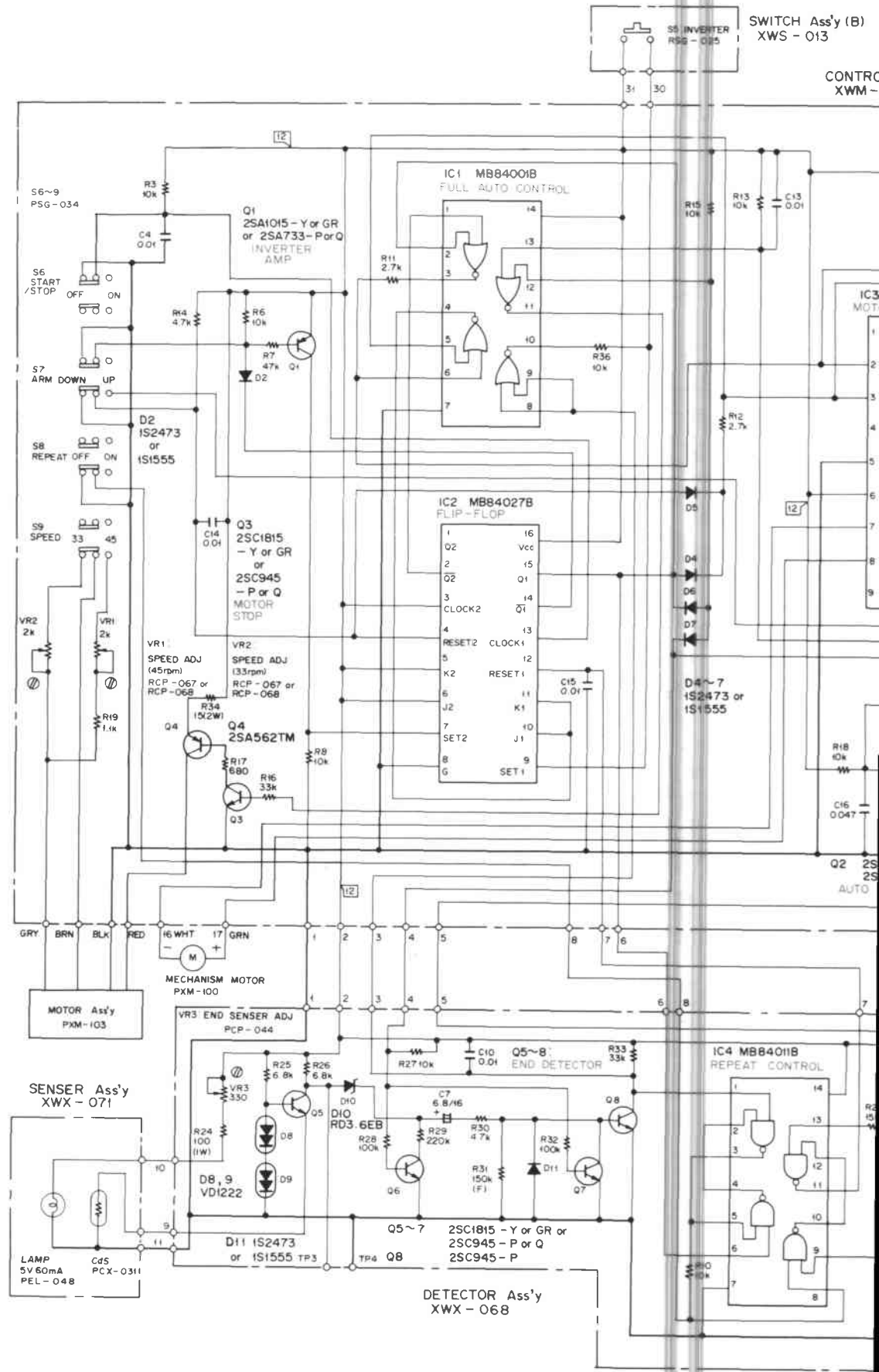

1

2

3

**NOTE:**

The indicated semiconductors are representative ones only. Other alternative semiconductors may be used and are listed in the parts list.

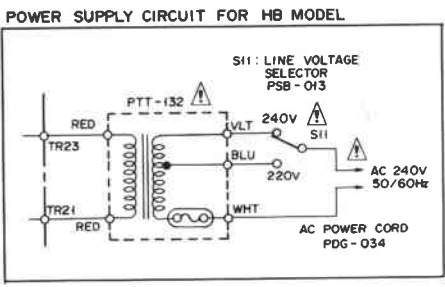
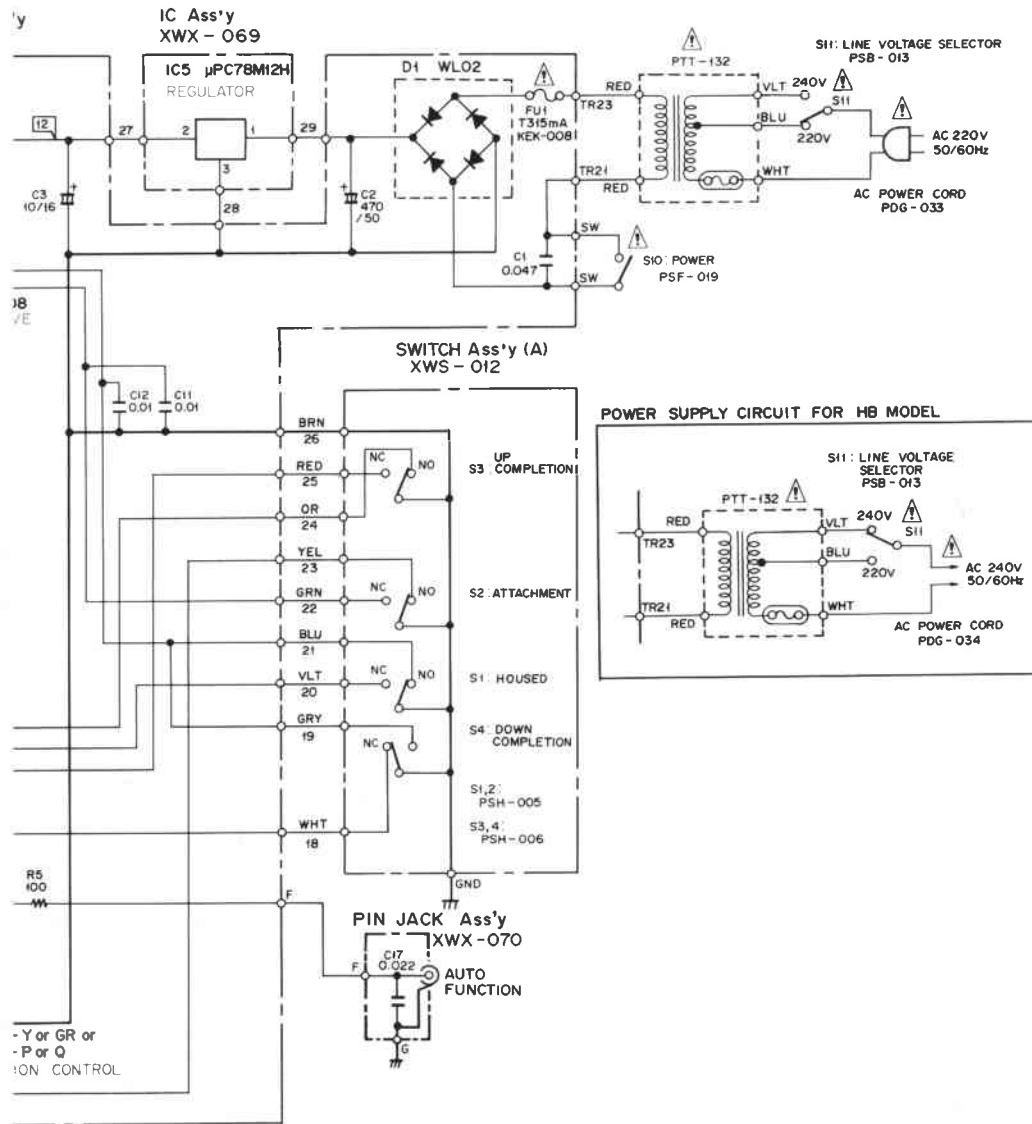

**1. RESISTORS:**

Indicated in Ω, ¼W, ±5% tolerance unless otherwise noted k : kΩ, M : MΩ, (F) : ±1%, (G) : ±2%, (K) : ±10%, (M) : ±20 % tolerance

**2. CAPACITORS:**

Indicated in capacity (μF)/voltage (V) unless otherwise noted p : pF Indication without voltage is 50V except electrolytic capacitor.

**3. VOLTAGE, CURRENT:**

⊖ : DC voltage (V) at no input signal  
 ↶ mA : DC current at no input signal

**4. OTHERS:**

⊗ : Adjusting point.  
 The ⚠ mark found on some component parts indicates the importance of the safety factor of the part. Therefore, when replacing, be sure to use parts of identical designation.

**SWITCHES:**

- S1 HOUSED ON - OFF
- S2 ATTACHMENT ON - OFF
- S3 UP COMPLETION ON - OFF
- S4 DOWN COMPLETION ON - OFF
- S5 INVERTER ON - OFF
- S6 START/STOP ON - OFF
- S7 ARM UP - DOWN
- S8 REPEAT ON - OFF
- S9 SPEED 33 1/3rpm - 45rpm
- S10 POWER ON - OFF
- S11 LINE VOLTAGE SELECTOR 220V - 240V

The underlined indicates the switch position.

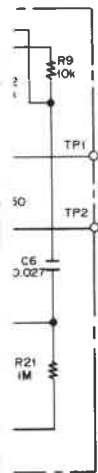

This is the basic schematic diagram, but the actual circuit may vary due to improvements in design.

A

B









C

D

## NOTES:

- Parts without part number cannot be supplied.
- The  mark found on some component parts indicates the importance of the safety factor of the part. Therefore, when replacing, be sure to use parts of identical designation.
- For your Parts Stock Control, the fast moving items are indicated with the marks **★★** and **★**.  
**★★ GENERALLY MOVES FASTER THAN ★.**  
This classification shall be adjusted by each distributor because it depends on model number, temperature, humidity, etc.

## Parts List

Mark	No.	Part No.	Description	Mark	No.	Part No.	Description	
	1.	PPZ30P080FMC	Screw		46.	PNX-231	Gear	
	2.	XWM-073	Control assembly		47.	PNX-232	Slide rail jack	
	3.	PAC-069	Button (B)		48.	PNX-230	Retainer	
	4.	PAC-068	Button (A)		49.	PNC-228	Slide rail	
	5.	PBH-303	Switch lever spring		50.	LMZ30P080FMC	Screw	
★★	6.	PSF-019	Microswitch		51.	PNX-232	Slide rail jack	
	7.	PNX-225	Power switch lever		52.	PBH-318	Spring (C)	
	8.	PPZ30P080FMC	Screw		53.	PMA40P050FMC	Screw	
	9.	PNX-330	Front panel		54.	PBM-008	Wire nut	
	10.	PEA-053	Rubber mat assembly		★	55.	PTT-132	Power transformer (240-220V)
	11.	PXB-225	Turntable platter assembly		56.	PBM-008	Wire nut	
	12.	PBH-298	Sensing pin spring		57.	PDZ30P060FZK	Screw	
	13.	PNX-226	Sensing pin		58.	XWX-069	IC assembly	
	14.	PNX-227	Sensing pin holder		59.	PEC-073	Stopper	
	15.	PMB30P080FMC	Screw		60.	PDZ30P060FMC	Screw	
	16.	PXB-236	Shaft assembly		61.	PEC-072	Foot	
	17.	PNX-222	Slide base cover		62.	VTZ30P080FMC	Screw	
★★	18.	PEB-183	Belt 		63.	PPZ30P050FMC	Screw	
	19.	VTZ30P050FZK	Screw		64.	PNC-198	Holder	
	20.	PNA-159	Bonnet		65.	YE30S	Washer	
	21.	PNX-220	Escutcheon cover		66.	PNX-237	Lead in ratch	
	22.	IPZ30P080FMC	Screw		67.	PBK-051	Plate spring	
	23.	PBH-300	Spring		68.	PNX-236	Driving plate	
	24.	PNX-239	Reset plate		69.	PMZ26P100FMC	Screw	
	25.	PNX-238	Record load sensor plate		70.	PMZ26P220FMC	Screw	
	26.	PBA-112	Screw		71.	XWS-012	Switch assembly	
	27.	PEB-172	Rubber cushion		72.	PDZ30P060FMC	Screw	
	28.	PNX-221	Slide base		73.	PEC-048	Strain relief	
★★	29.	PYY-105	Motor assembly 		74.	VDZ30P060FMC		
	30.	PDE-101	Connector assembly (M)		75.	PDG-033	Power cord (HE)	
	31.	VTZ30P060FMC	Screw		75.	PDG-034	Power cord (HB)	
	32.	YE30S	Washer		76.	PKE-001	Screw	
	33.	PXB-238	Lock lever assembly		77.	IDZ30P060FZK	Screw	
	34.	PBH-301	Spring		78.	PDE-100	PU cord	
	35.	PNX-234	Lock lever reset plate		79.	PPZ30P080FZK	Screw	
	36.	YE30S	Washer		80.	XWX-070	Pin jack assembly	
	37.	WA41D065D025	Screw		81.	PNX-242	EP adaptor	
	38.	PNX-233	Lack gear		82.	XWS-013	Switch assembly (B)	
	39.	PBA-121	Screw		83.	XWX-068	Sensing assembly	
	40.	PEB-186	Damper rubber		84.	WA35F100N080	Washer	
	41.	PBH-317	Spring (B)		85.	PBH-323	Spring (D)	
	42.	PBH-310	Spring (A)		86.	PBA-129	Screw	
	43.	PXT-466	Base unit		87.	PBT-001	Steel ball 4φ	
	44.	PBA-120	Screw		88.	PBT-002	Steel ball 5.5φ	
	45.	PBK-050	Plate spring		★★	89.	PNX-331	Line voltage selector



11.3 CHASSIS

Parts List

Mark	No.	Part No.	Description
	1.	PXT-455	Chassis unit
	2.	PLB-127	Gear A shaft
	3.	PNC-199	Shield plate
★★	4.	PXM-100	Motor
	5.	PNX-240	Gear A
	6.	YE30S	Washer
	7.	PNX-241	Gear B
	8.	.....	.....
	9.	PNX-306	Gear C
	10.	PEB-184	Damper rubber
	11.	PBA-125	Screw
	12.	PLM-006	Motor pulley
★★	13.	PEB-185	Belt
	14.	PNX-308	Pulley

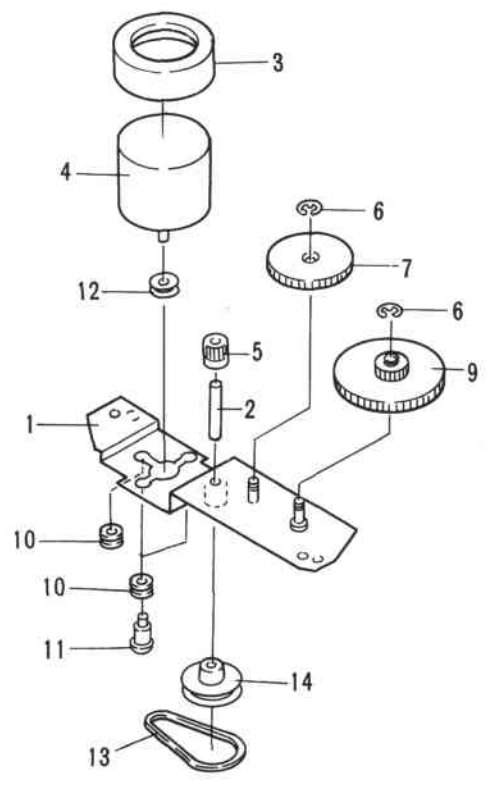

1

2

3

A

B

C

D

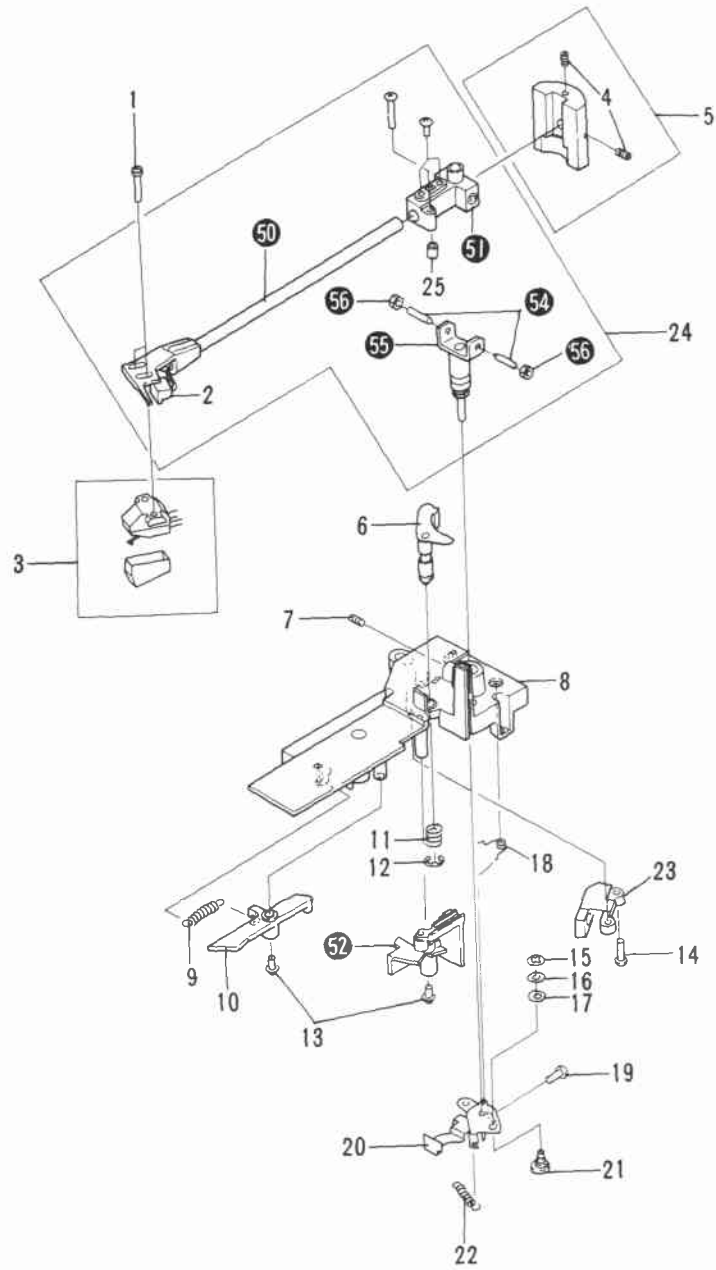

1

2

3

Mark	No.	Part No.	Description
	100.		Rail cover
	101.		Under base
	102.		Driving plate assembly
	103.		Transformer shield plate
	104.		Plate

## 11.2 TONEARM

### Parts List

Mark	No.	Part No.	Description
	1.	KBA-043	Cartridge mounting screw
	2.	PXA-888	Cartridge connector assembly
	3.	PPB-933	Cartridge assembly (PC3MC)
	4.	ZMK40H100FBT	Screw
★	5.	PNR-524	Weight
	6.	PXT-449	EV sheet unit
	7.	ZM040H100FZK	Screw
	8.	PNX-223	Tonearm base
	9.	PBH-300	Reset lever spring
	10.	PNX-229	Reset lever
	11.	PBH-237	EV spring
	12.	YE70S	Washer
	13.	IPZ30P080FMC	Screw
	14.	PPZ30P080FMC	Screw
	15.	YS40S	Washer
	16.	WC40FMC	Washer
	17.	PNC-227	PU spring washer
	18.	PBH-297	AS spring
	19.	ZMD40H060FMC	Screw
	20.	PXB-251	PU plate assembly
	21.	PNX-228	Cam
	22.	PBH-299	PU plate spring
	23.	XWX-071	Sensor assembly
★	24.	PPD-614	Tonearm assembly
	25.	PNW-702	EV chip
	50.		Tonearm pipe assembly
	51.		Pipe holder assembly
	52.		Index cam assembly
	53.		.....
	54.		Pivot
	55.		Holder assembly
	56.		Nut

## 12. RÉGLAGE

### 12.1 RÉGLAGE DE LA POSITION DE DESCENTE DE LA POINTE DE LECTURE

Régler la position de descente de la pointe de lecture en suivant les instructions indiquées ci-dessous lorsque la pointe de lecture ne se pose pas sur le disque à l'endroit approprié. Prendre soin de ne pas abîmer le disque pendant le réglage.

1. Appuyer sur la touche START/STOP et commencer la lecture.
2. Déterminer la marge d'erreur et la direction de la pointe de lecture.
3. Placer le commutateur d'élévation du bras de lecture sur la position (▼).
4. Tourner la vis de réglage en suivant les instructions indiquées dans les chapitres ci-dessous à l'aide d'un petit tournevis plat (appuyer doucement sur le tournevis en tournant).
  - Un demi tour de la vis de réglage change la position de descente de la pointe de lecture d'environ 10mm.
  - Si la pointe de lecture descend trop vers l'extérieur, tourner la vis dans le sens des aiguilles d'une montre (comme indiqué ci-dessus).
  - Si la pointe de lecture descend trop vers l'intérieur, tourner la vis dans le sens contraire (comme indiqué ci-dessus).
5. Vérifier de nouveau les réglages.

Après avoir effectué le réglage, appuyer doucement sur la fiche dans la direction de la flèche et s'assurer que la pointe de lecture se pose sur le sillon de début du disque (le bras est réglé sur le mode de lecture jusqu'à l'arrêt.)

#### Précautions à prendre pendant le réglage

- Ne pas trop pencher et pas retourner la platine pendant le réglage.
- Ne pas exercer de pression trop forte en tournant la vis de réglage avec le tournevis.

Position de l'orifice de réglage vue du dessous de l'appareil.

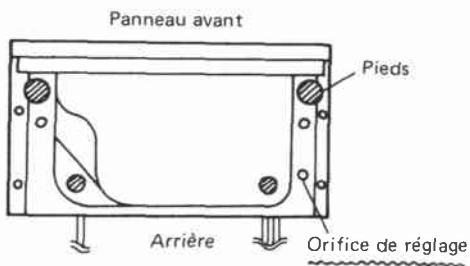

Fig. 12-1 Réglage de la position de descente de la pointe de lecture

### 12.2 RÉGLAGE DE LA HAUTEUR D'ÉLEVATION DU BRAS DE LECTURE

Tourner la vis de réglage comme indiqué sur la Fig. 12-2. pour effectuer le réglage de la hauteur d'élévation du bras de lecture. Tourner la vis dans la direction CW pour diminuer la hauteur et tourner la vis dans la direction CCW pour augmenter la hauteur. La hauteur doit être réglée de manière que la pointe de lecture soit à  $7 \pm 2$ mm de la surface du disque. La pointe de lecture peut éventuellement frotter sur le disque lorsque le bras revient sur sa position de départ si la hauteur au dessus du disque est trop faible. En général, ce réglage n'est pas nécessaire mais il doit être effectué avant le réglage de la position de descente de la pointe de lecture en cas de nécessité de réglage.

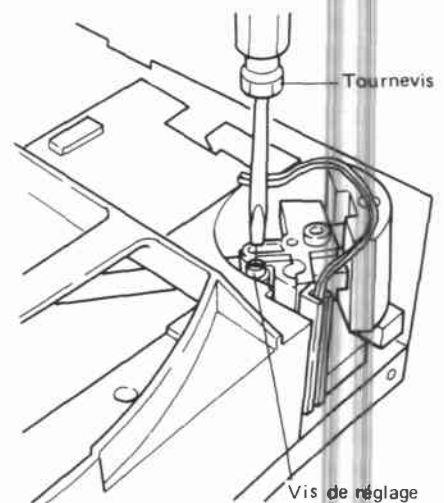
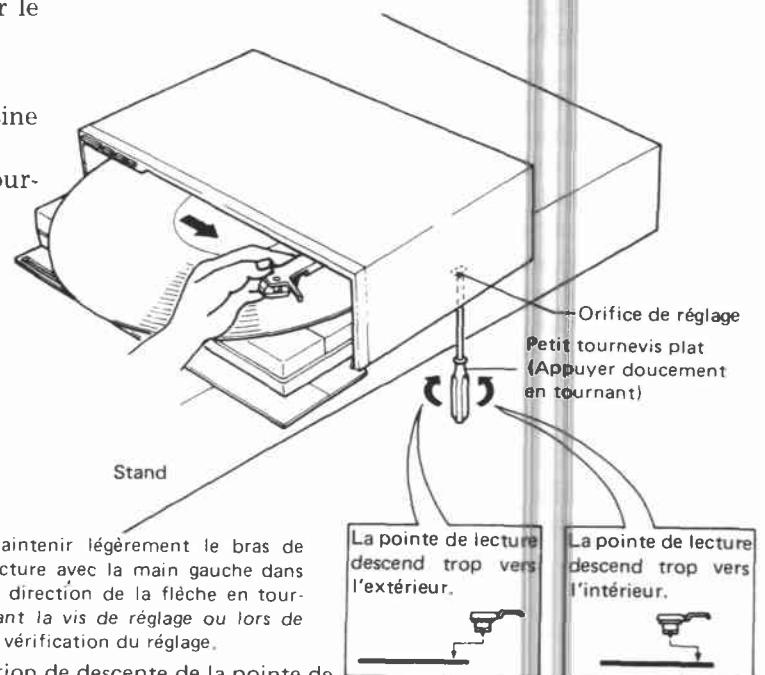

Fig. 12-2 Réglage de la hauteur d'élévation du bras



### 12.3 RÉGLAGE DU CIRCUIT DU SENSEUR DE POINTE

1. Toujours effectuer le réglage de la position de descente de la pointe de lecture avant le réglage du circuit du senseur de tête. Enlever également le couvercle de l'appareil pour effectuer ce réglage.
2. Régler l'appareil sur le mode de lecture et couper l'alimentation électrique. Débrancher ensuite le raccord (CN) de la plaquette de circuit afin de s'assurer que le moteur d'entraînement et le moteur de la platine ne tournent pas.
3. Raccorder un voltmètre CC entre TP3 et TP4 (GND) comme indiqué sur la Fig. 12-3. Mettre l'appareil sous tension et régler la position de la pointe de lecture du bras sur 47,5mm à partir de l'axe central. Noter la tension indiquée sur le voltmètre sur cette position. (Fig. 12-4)
4. Régler ensuite la pointe de lecture sur 57,5mm à partir de l'axe central et régler VR3 afin que le voltmètre indique  $5,6V \pm 0,2V$  de moins que l'indication précédente.

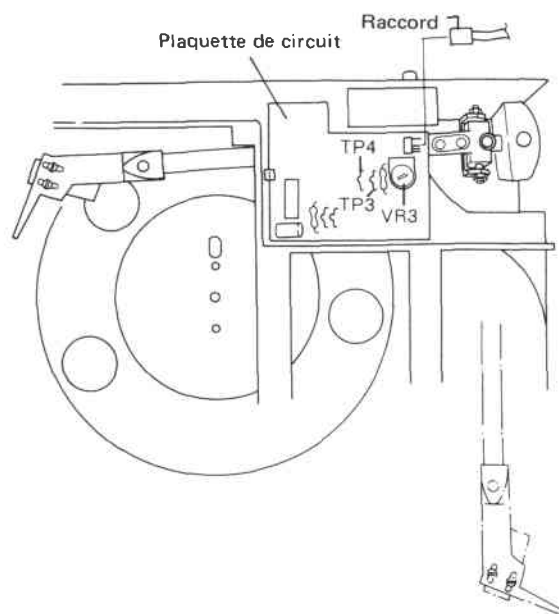

Fig. 12-3 Réglage du senseur de pointe (1)

### 12.4 RÉGLAGE DE LA VITESSE DU MOTEUR DE LA PLATINE

1. Placer un stroboscope sur le plateau de la platine et mettre l'appareil sous tension.
2. Régler VR pour le réglage de vitesse situé sur le panneau arrière de l'appareil. La vitesse de rotation est altérée si VR et le couvercle entrent en contact lors du réglage VR. Lorsqu'un tournevis métallique est utilisé pour ce réglage, toujours enrouler la tige du tournevis de ruban isolant et essayer d'éviter tout contact avec le couvercle (Fig. 12-5).

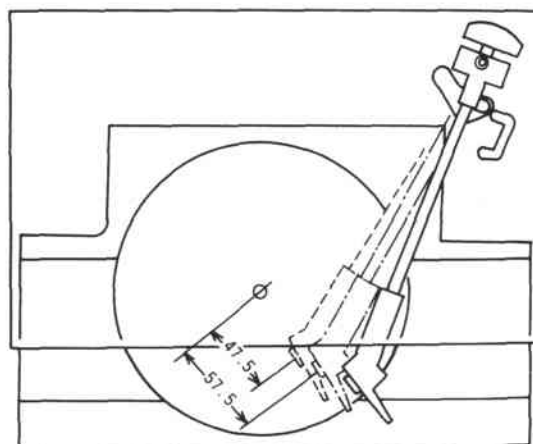

Fig. 12-4 Réglage du senseur de pointe(2)

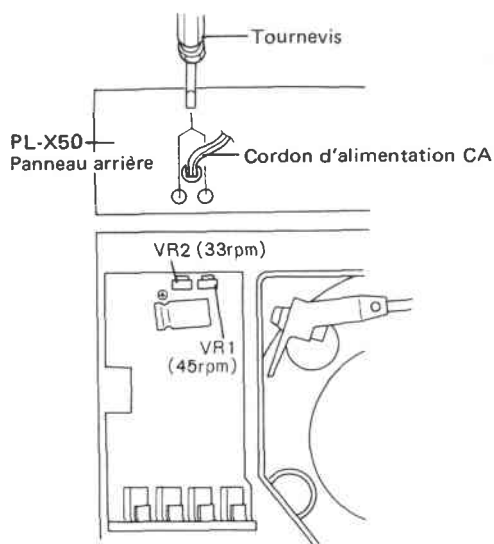

Fig. 12-5 Réglage de la vitesse du moteur de la platine

## 12.2 ARM ELEVATION HEIGHT ADJUSTMENT

The elevation seat height adjustment is performed by turning the adjustment screw as shown in Fig. 12-2. Turning the screw in a CW direction lowers the height, and turning CCW raises it. The height should be adjusted so the stylus is  $7 \pm 2\text{mm}$  above the record disc. If the height is too low, the stylus could possibly drag on the record during its return movement. This adjustment is not normally required, however, it should be made prior to adjusting the stylus lowering position when necessary.

## 12.3 END SENSOR CIRCUIT ADJUSTMENT

1. Always perform the stylus lowering position adjustment prior to adjusting the end sensor circuit. Also, remove the bonnet case (hood) from the unit to make this adjustment.
2. With the unit in playback status, turn off the power switch. Then, disconnect the connector (CN) from the circuit board assembly to make sure the mechanism motor and turntable motor does not move.
3. Connect a DC voltage meter between TP3 and TP4 (GND) as shown in Fig. 12-3 Turn the power switch on, and position the stylus of the tonearm 47.5mm from the center shaft. Read the voltage from the voltage meter at this position. (Fig. 12-4).
4. Next, position the stylus 57.5mm from the center shaft and adjust VR3 to where the voltage meter reads  $5.6\text{V} \pm 0.2\text{V}$  less than the last reading.

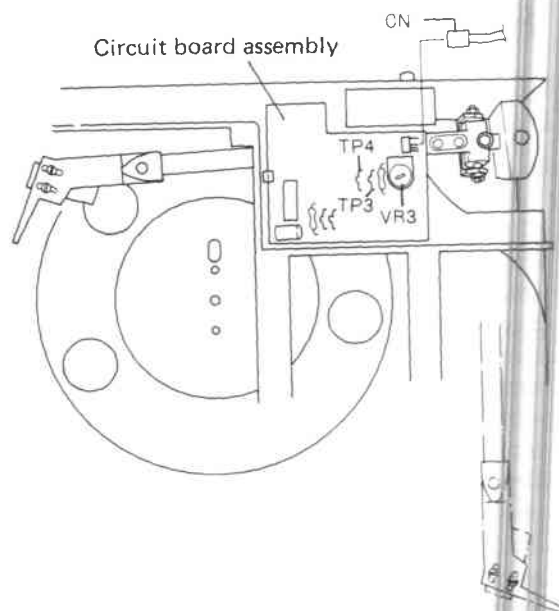

Fig. 12-3 End sensor adjustment 1

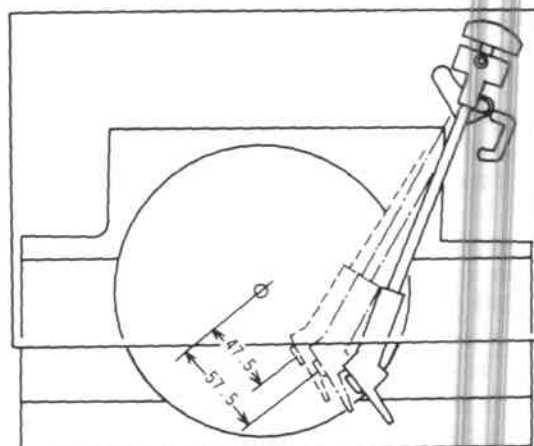

Fig. 12-4 End sensor adjustment 2

## 12.4 TURNTABLE MOTOR SPEED ADJUSTMENT

1. Place a stroboscope on the turntable platter and turn the power switch on.
2. Adjust the speed adjustment VR on the rear panel of the unit. When adjusting this VR, if contact is made between the bonnet and the VR, rotational speed will be affected. When using a metal screwdriver to make this adjustment, always wrap tape around the shank of the screwdriver and try not to make contact with the bonnet (Fig. 12-5).

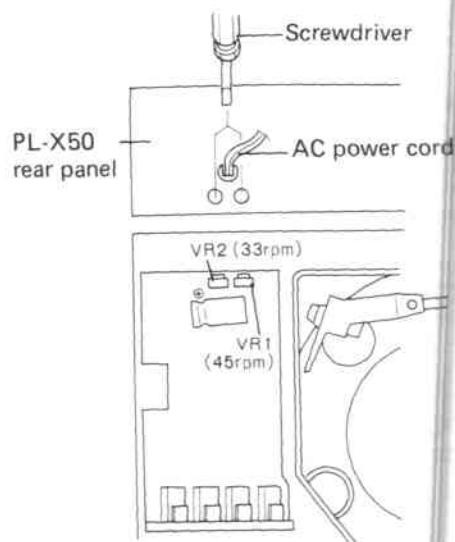

Fig. 12-5 Turntable motor speed adjustment

## 12. ADJUSTMENTS

### 12.1 ADJUSTING STYLUS LOWERING POSITION

If the stylus does not lower to the proper position on the record disc during playback, adjust it following the steps listed below. Take care not to damage the record during the adjustment procedure.

1. Depress the START/STOP button and start playback.
2. Determine the direction and amount in which the stylus is off.
3. Place the arm elevation switch in the (▼) position.
4. Using a small flat-blade screwdriver, turn the adjustment screw as listed in the steps below (press down lightly with the screwdriver as you are turning it).
  - Turning the adjustment screw one-half turn will change the lowering position of the stylus by approximately 10mm.
  - If the stylus lowers too far toward the outside...  
Turn the screw clockwise (as seen from above).
  - If the stylus lowers too far toward the inside...  
Turn the screw counterclockwise (as seen from above).

5. Recheck the adjustments.

After the adjustment is completed, gently push the headshell in the direction of the arrow, and make certain the stylus stops at the lead-in groove position on the outer circumference of the record disc (the tonearm should be in the playback mode until the stop position).

#### Adjustment Precautions

- Do not tilt the turntable excessively or turn it upside-down during adjustment.
- When turning the adjustment screw, do not use excessive force in pressing down with the screwdriver.

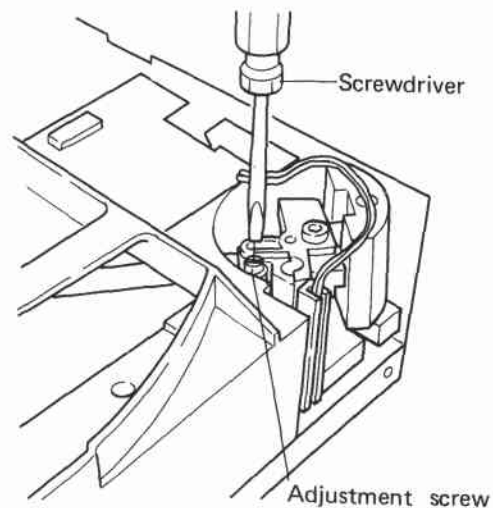

Fig. 12-2 Arm elevation height adjustment

Adjustment hole position  
(Viewed from the bottom of the unit)  
Front side

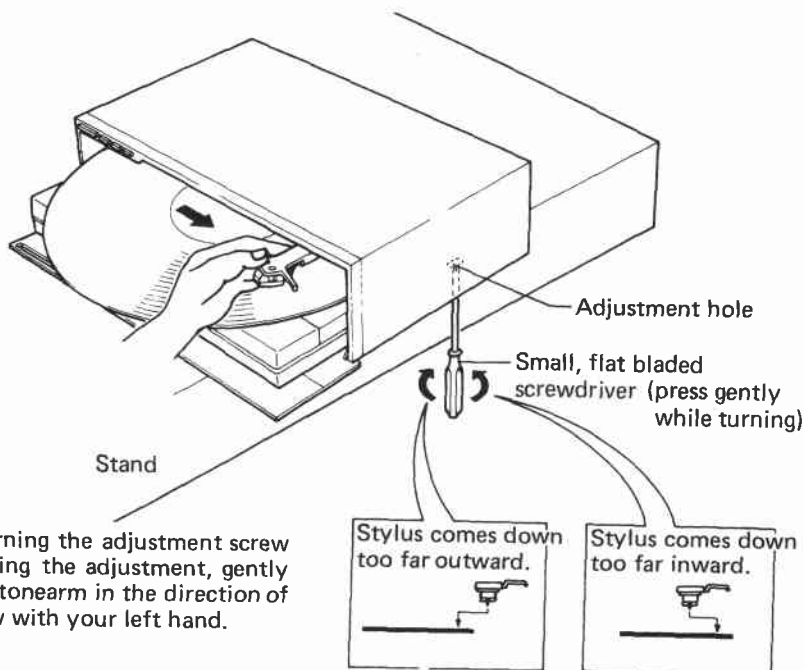
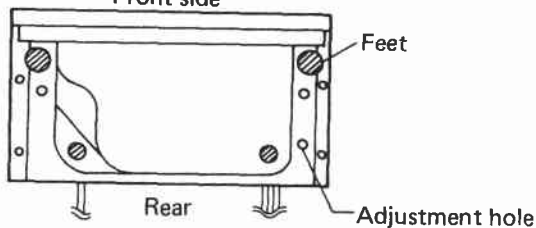

Fig. 12-1 Adjusting the stylus lowering position

## 12. RÉGLAGE

### 12.1 RÉGLAGE DE LA POSITION DE DESCENTE DE LA POINTE DE LECTURE

Régler la position de descente de la pointe de lecture en suivant les instructions indiquées ci-dessous lorsque la pointe de lecture ne se pose pas sur le disque à l'endroit approprié. Prendre soin de ne pas abîmer le disque pendant le réglage.

1. Appuyer sur la touche START/STOP et commencer la lecture.
2. Déterminer la marge d'erreur et la direction de la pointe de lecture.
3. Placer le commutateur d'élévation du bras de lecture sur la position (▼).
4. Tourner la vis de réglage en suivant les instructions indiquées dans les chapitres ci-dessous à l'aide d'un petit tournevis plat (appuyer doucement sur le tournevis en tournant).
  - Un demi tour de la vis de réglage change la position de descente de la pointe de lecture d'environ 10mm.
  - Si la pointe de lecture descend trop vers l'extérieur, tourner la vis dans le sens des aiguilles d'une montre (comme indiqué ci-dessus).
  - Si la pointe de lecture descend trop vers l'intérieur, tourner la vis dans le sens contraire (comme indiqué ci-dessus).
5. Vérifier de nouveau les réglages.

Après avoir effectué le réglage, appuyer doucement sur la fiche dans la direction de la flèche et s'assurer que la pointe de lecture se pose sur le sillon de début du disque (le bras est réglé sur le mode de lecture jusqu'à l'arrêt.)

#### Précautions à prendre pendant le réglage

- Ne pas trop pencher et pas retourner la platine pendant le réglage.
- Ne pas exercer de pression trop forte en tournant la vis de réglage avec le tournevis.

Position de l'orifice de réglage vue du dessous de l'appareil.

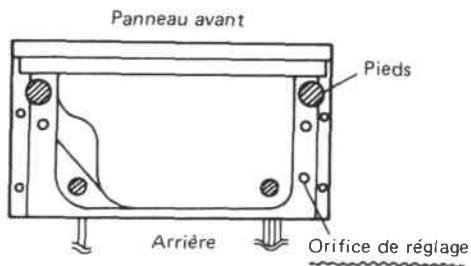

Fig. 12-1 Réglage de la position de descente de la pointe de lecture

### 12.2 RÉGLAGE DE LA HAUTEUR D'ÉLEVATION DU BRAS DE LECTURE

Tourner la vis de réglage comme indiqué sur la Fig. 12-2. pour effectuer le réglage de la hauteur d'élévation du bras de lecture. Tourner la vis dans la direction CW pour diminuer la hauteur et tourner la vis dans la direction CCW pour augmenter la hauteur. La hauteur doit être réglée de manière que la pointe de lecture soit à  $7 \pm 2\text{mm}$  de la surface du disque. La pointe de lecture peut éventuellement frotter sur le disque lorsque le bras revient sur sa position de départ si la hauteur au dessus du disque est trop faible. En général, ce réglage n'est pas nécessaire mais il doit être effectué avant le réglage de la position de descente de la pointe de lecture en cas de nécessité de réglage.

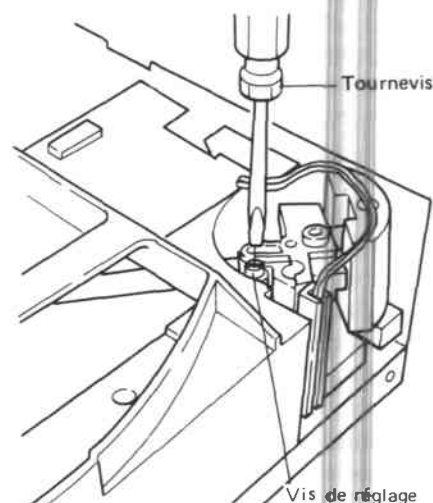
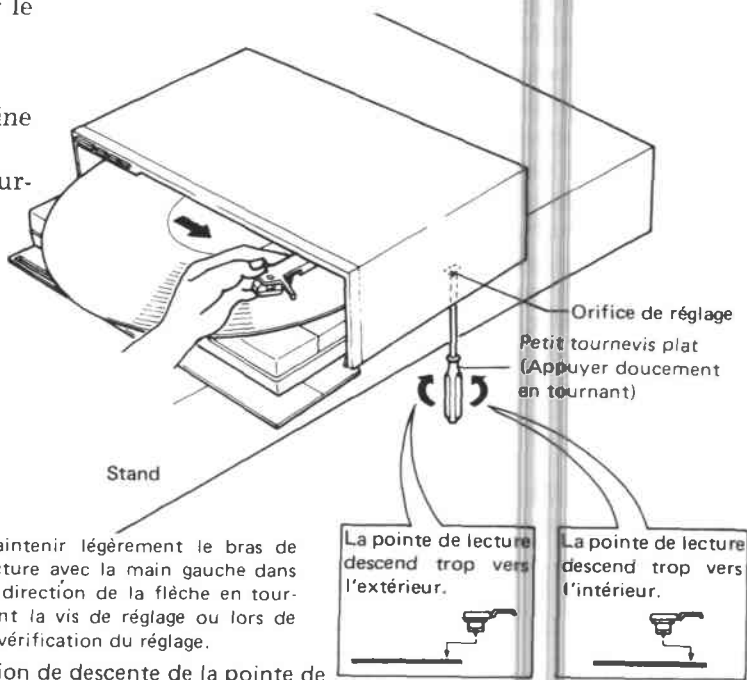

Fig. 12-2 Réglage de la hauteur d'élévation du bras





### 12.3 RÉGLAGE DU CIRCUIT DU SENSEUR DE POINTE

1. Toujours effectuer le réglage de la position de descente de la pointe de lecture avant le réglage du circuit du senseur de tête. Enlever également le couvercle de l'appareil pour effectuer ce réglage.
2. Régler l'appareil sur le mode de lecture et couper l'alimentation électrique. Débrancher ensuite le raccord (CN) de la plaquette de circuit afin de s'assurer que le moteur d'entraînement et le moteur de la platine ne tournent pas.
3. Raccorder un voltmètre CC entre TP3 et TP4 (GND) comme indiqué sur la Fig. 12-3. Mettre l'appareil sous tension et régler la position de la pointe de lecture du bras sur 47,5mm à partir de l'axe central. Noter la tension indiquée sur le voltmètre sur cette position. (Fig. 12-4)
4. Régler ensuite la pointe de lecture sur 57,5mm à partir de l'axe central et régler VR3 afin que le voltmètre indique  $5,6V \pm 0,2V$  de moins que l'indication précédente.

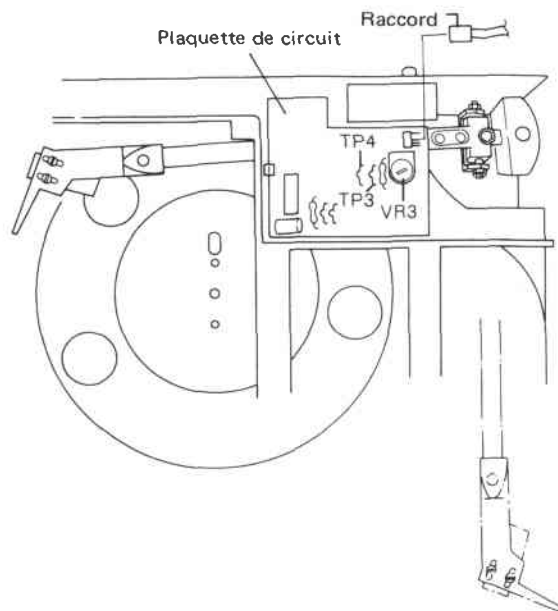

Fig. 12-3 Réglage du senseur de pointe (1)

### 12.4 RÉGLAGE DE LA VITESSE DU MOTEUR DE LA PLATINE

1. Placer un stroboscope sur le plateau de la platine et mettre l'appareil sous tension.
2. Régler VR pour le réglage de vitesse situé sur le panneau arrière de l'appareil. La vitesse de rotation est altérée si VR et le couvercle entrent en contact lors du réglage VR. Lorsqu'un tournevis métallique est utilisé pour ce réglage, toujours enrouler la tige du tournevis de ruban isolant et essayer d'éviter tout contact avec le couvercle (Fig. 12-5).

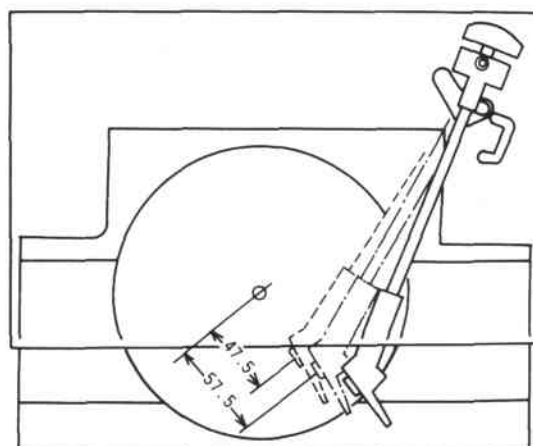

Fig. 12-4 Réglage du senseur de pointe(2)

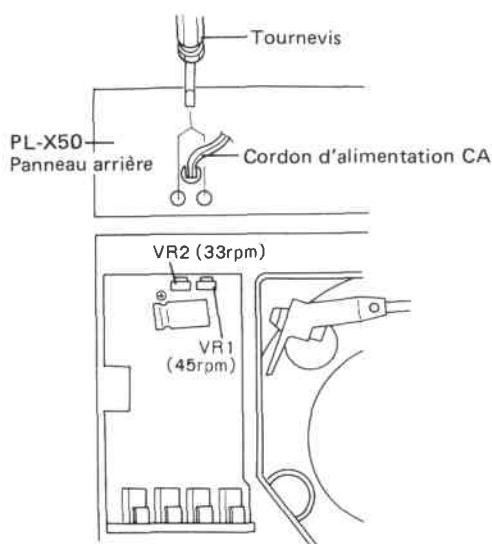
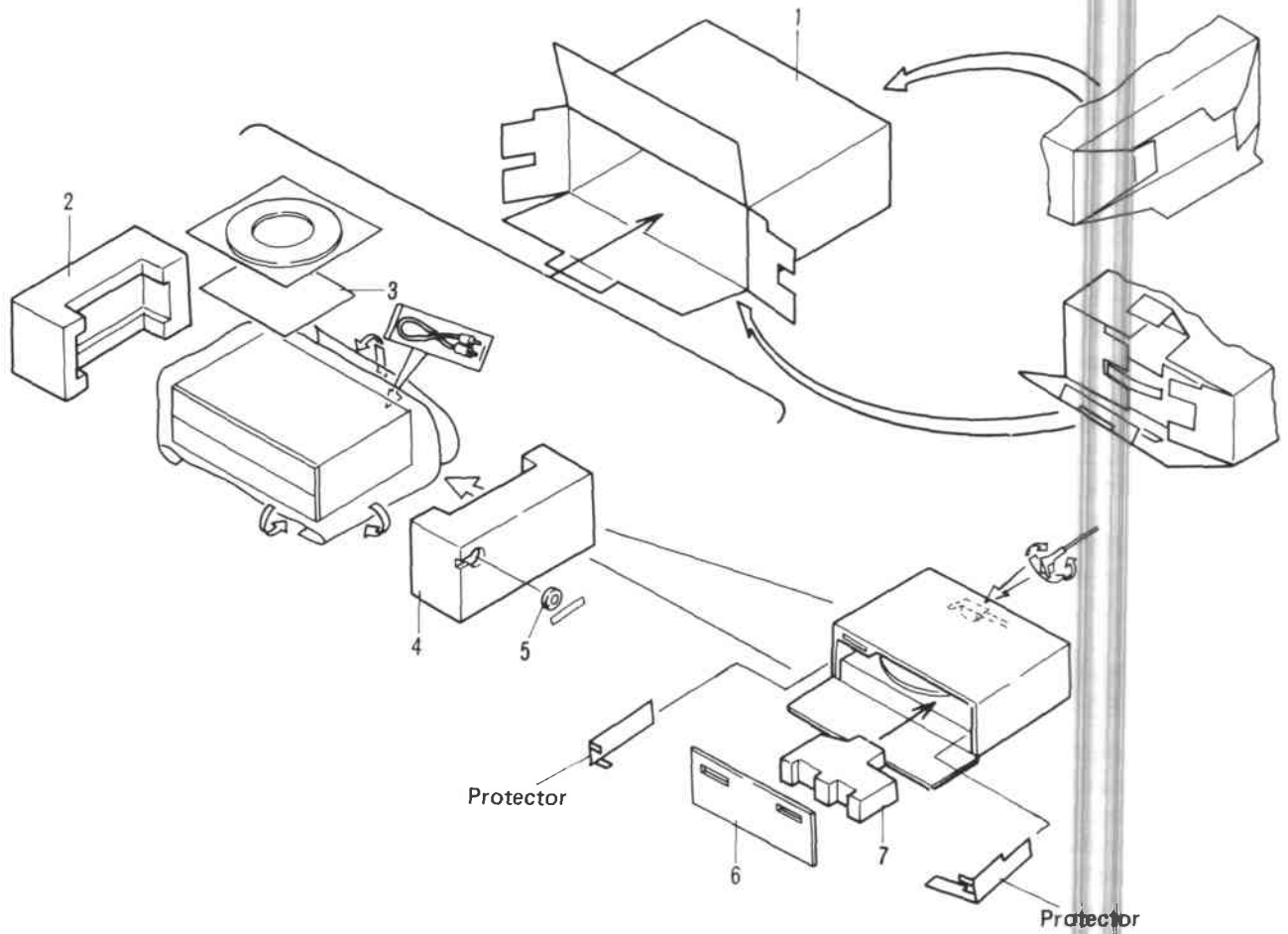

Fig. 12-5 Réglage de la vitesse du moteur de la platine

### 13. PACKING



#### Parts List

Mark	No.	Part No.	Description
	1.	PHG-468	Packing case (HE)
		PHG-470	Packing case (HB)
	2.	PHA-129	Protector (L)
	3.	PRD-069	Operating instructions (HE)
		PRB-199	Operating instructions (HB)
	4.	PHA-130	Protector (R)
	5.	PNX-242	EP adaptor
	6.	PHC-083	Spacer
	7.	PHA-134	Turntable packing

# 12. AJUSTE

## 12.1 AJUSTE DE LA POSICIÓN DE DESCENSO DE LA AGUJA

Si la aguja no desciende en la posición correcta sobre el disco durante la reproducción, ajustar la siguiente los pasos que se describen a continuación. Tener cuidado de no dañar el disco durante el procedimiento de ajuste.

1. Presionar el botón de START/STOP y iniciar la reproducción.
2. Determinar la dirección y cantidad de des-centración de la aguja.
3. Poner el conmutador de elevación del brazo en la posición (▼).
4. Utilizando un pequeño destornillador de cabeza plana, girar el tornillo de ajuste como se describe en los pasos siguientes (presionar ligeramente el destornillador a medida que se vaya girando).
  - Al girar el tornillo de ajuste media vuelta se cambia la posición de descenso de la aguja aproximadamente 10mm.
  - Si la aguja desciende muy hacia afuera. Gire el tornillo en sentido de las agujas del reloj (como se observa anteriormente).
  - Si la aguja desciende muy hacia adentro. Gire el tornillo en el sentido contrario a las agujas del reloj (como se observa anteriormente).
5. Volver a comprobar los ajustes

Una vez completado el ajuste, presionar ligeramente la cabeza fonocaptora en el sentido de la flecha, y cerciorarse de que la aguja para en la posición del surco de inicio de la circunferencia exterior del disco (el brazo fonocaptor deberá estar en el modo de reproducción hasta la posición de parada).

### Precauciones en el ajuste

- No inclinar excesivamente el giradiscos ni ponerlo al revés durante el ajuste.
- Al girar el tornillo de ajuste, no aplicar demasiada fuerza al presionar el destornillador.

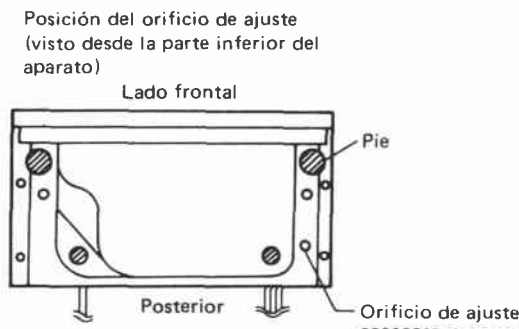

Fig. 12-1 Ajuste de la posición de descenso de la aguja

## 12.2 AJUSTE DE LA ALTURA DE ELEVACIÓN DEL BRAZO

El ajuste de la altura del asiento de elevación se realiza girando el tornillo de ajuste como se muestra en la Fig. 12-2. Girando el tornillo hacia la derecha se hace descender la altura, y girándolo hacia la izquierda se eleva. La altura deberá ajustarse de modo que la aguja esté  $7 \pm 2\text{mm}$  sobre el disco. Si la altura es demasiado baja, la aguja puede marcar el disco durante el movimiento de retorno. Generalmente no se requiere este ajuste, sin embargo, deberá realizarse antes de ajustar la posición de descenso de la aguja cuando éste resulte necesario.

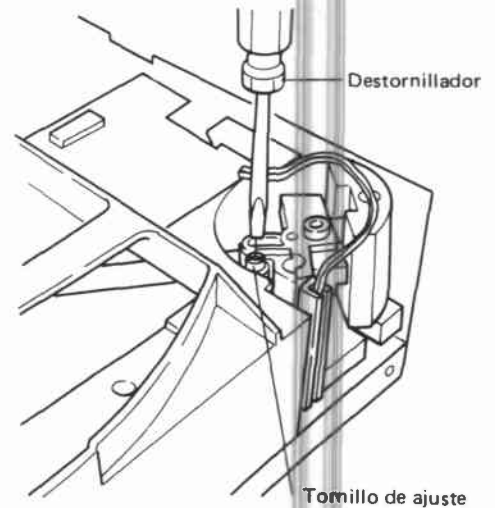
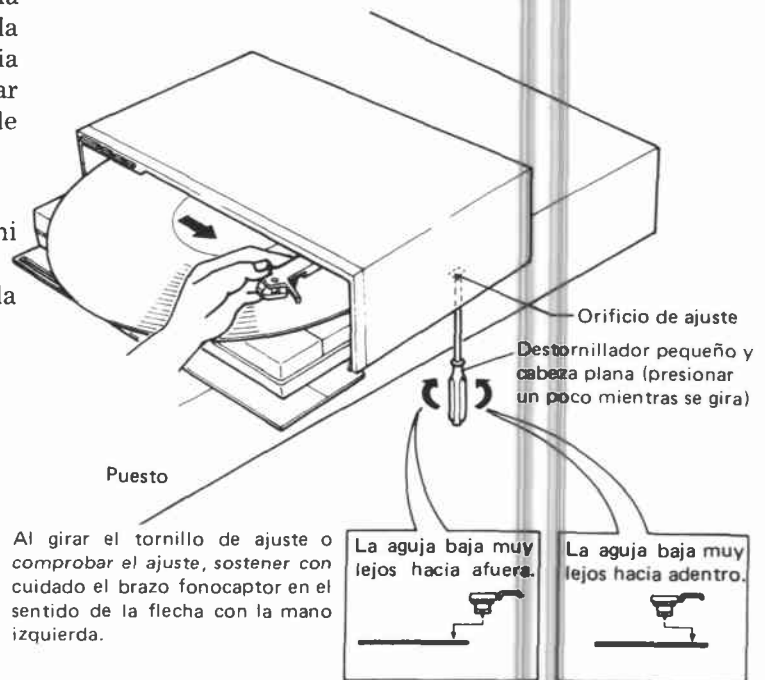

Fig. 12-2 Ajuste de la altura de elevación del brazo



### 12.3 AJUSTE DEL CIRCUITO SENSOR DE FINALIZACIÓN

1. Realizar siempre el ajuste de la posición de descenso de la aguja antes del ajuste del circuito sensor de finalización. También, extraer la cubierta del aparato para realizar este ajuste.
2. Con el aparato en el modo de reproducción, desconectar el interruptor de la alimentación. Luego desconectar el conector (CN) del conjunto de la tablilla del circuito para cerciorarse de que el motor del mecanismo y el motor del giradiscos no se mueven.
3. Conectar un voltímetro de CC entre el TP3 y TP4 (GND) como se muestra en la Fig. 12-3. Conectar el interruptor de la alimentación y poner la aguja del brazo fonocaptor 47,5mm del eje central. Leer la tensión del voltímetro en esta posición (Fig. 12-4).
4. Luego, poner la aguja 57,5mm del eje central y ajustar el VR3 en el punto donde se indique la tensión de  $5,6V \pm 0,2V$  menos que la de la última lectura.

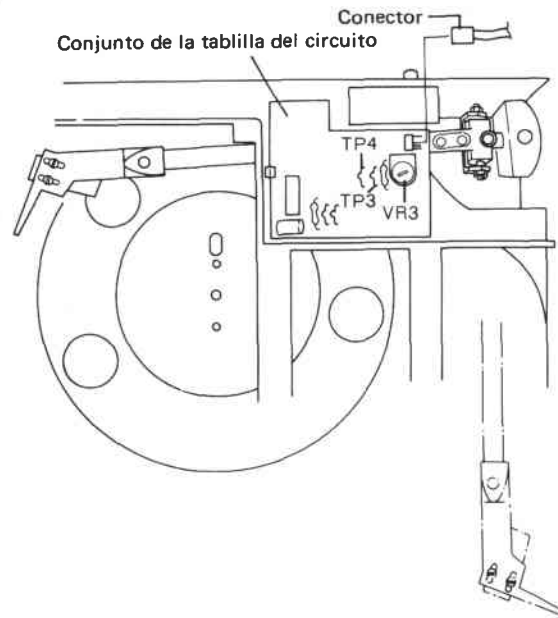

Fig. 12-3 Ajuste 1 del sensor de finalización

### 12.4 AJUSTE DE LA VELOCIDAD DEL MOTOR DEL GIRADISCOS

1. Poner un estroboscopio en el plato del giradiscos y conectar el interruptor de la alimentación.
2. Ajustar el VR de ajuste de la velocidad, de la parte posterior del aparato. Al ajustar este VR, si hay contacto entre la cubierta y el VR, se afectará la velocidad de rotación. Cuando se utilice un destornillador metálico para realizar este ajuste, enropear siempre en torno al mango del destornillador y intentar no hacer contacto con la cubierta (Fig. 12-5).

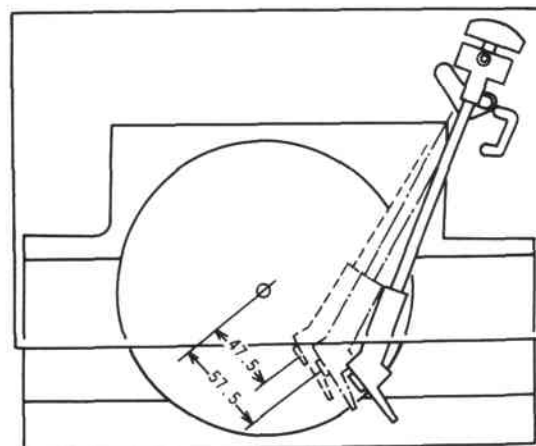

Fig.12-4 Ajuste 2 del sensor de finalización

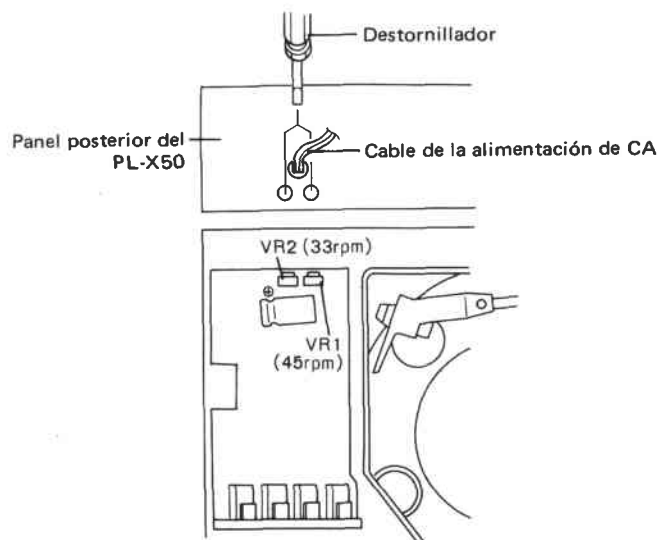

Fig. 12-5 Ajuste de la velocidad del motor del giradiscos