

Stereo Cassette Deck

Operating Instructions

TC-WR635S/MR535

WARNING

to prevent fire or shock hazard, do not expose the unit to rain or moisture.



CAUTION
RISK OF ELECTRIC SHOCK
DO NOT OPEN



CAUTION: TO REDUCE THE RISK OF ELECTRIC SHOCK,
DO NOT REMOVE COVER (OR BACK).
NO USER-SERVICEABLE PARTS INSIDE.
REFER SERVICING TO QUALIFIED SERVICE PERSONNEL.



This symbol is intended to alert the user to the presence of uninsulated "dangerous voltage" within the product's enclosure that may be of sufficient magnitude to constitute a risk of electric shock to persons.



This symbol is intended to alert the user to the presence of important operating and maintenance (servicing) instructions in the literature accompanying the appliance.

Owner's Record

The model and serial numbers are located on the rear of the unit. Record the serial number in the space provided below. Refer to them whenever you call upon your Sony dealer regarding this product.

Model No. _____ Serial No. _____

INFORMATION

This equipment has been tested and found to comply with the limits for a Class B digital device, pursuant to Part 15 of the FCC Rules. These limits are designed to provide reasonable protection against harmful interference in a residential installation. This equipment generates, uses, and can radiate radio frequency energy and, if not installed and used in accordance with the instructions, may cause harmful interference to radio communications. However, there is no guarantee that interference will not occur in a particular installation. If this equipment does cause harmful interference to radio or television reception, which can be determined by turning the equipment off and on, the user is encouraged to try to correct the interference by one or more of the following measures:

- Reorient or relocate the receiving antenna.
- Increase the separation between the equipment and receiver.
- Connect the equipment into an outlet on a circuit different from that to which the receiver is connected.
- Consult the dealer or an experienced radio/TV technician for help.

CAUTION

You are cautioned that any change or modifications not expressly approved in this manual could void your authority to operate this equipment.

For the customers in Canada



CAUTION

TO PREVENT ELECTRIC SHOCK, DO NOT USE THIS POLARIZED AC PLUG WITH AN EXTENSION CORD, RECEPTACLE OR OTHER OUTLET UNLESS THE BLADES CAN BE FULLY INSERTED TO PREVENT BLADE EXPOSURE.

This apparatus complies with the Class B limits for radio noise emissions set out in Radio Interference Regulations.

NOTICE FOR THE CUSTOMERS IN THE UNITED KINGDOM

A moulded plug complying with BS 1363 is fitted to this equipment for your safety and convenience.

Should the fuse in the plug supplied need to be replaced, a 5 AMP fuse approved by ASTA or BSI to BS 1362, (i.e. marked with  or  mark) must be used.

If the plug supplied with this equipment has a detachable fuse cover, be sure to attach the fuse cover after you change the fuse. Never use the plug without the fuse cover. If you should lose the fuse cover, please contact your nearest Sony service station.

IMPORTANT

If the plug supplied is not suitable for the socket outlets in your home, it should be cut off and an appropriate plug fitted in accordance with the following instructions.

The wires in this mains lead are coloured in accordance with the following code:

Blue: Neutral

Brown: Live

As the colours of the wires in the mains lead of this apparatus may not correspond with the coloured markings identifying the terminals in your plug, proceed as follows: The wire which is coloured blue must be connected to the terminal which is marked with the letter N or coloured black. The wire which is coloured brown must be connected to the terminal which is marked with the letter L or coloured red. Do not connect either wire to the earth terminal in the plug which is marked by the letter E or by the safety earth symbol  or coloured green or green and yellow.

WARNING

To prevent shock hazard, do not insert the plug cut off from the mains lead into a socket outlet. This plug cannot be used and should be destroyed.

Table of Contents

Chapter 1 Getting Started	
Features	3
Precautions	4
Unpacking	4
Checking the supplied accessories	4
Notes on installation	4
Checking the operating voltage	4
Hooking up the system	5
Before you begin	5
Hook-up example	5
Identifying the parts	6
Front panel	6
Chapter 2 Playback	
Playing back	7
Playing back both decks in succession — Relay Play	8
Locating a selection	
— Multi-AMS (Automatic Music Sensor)	9
Playing back automatically after rewinding — Auto Play	10
Locating a desired position using the counter	
— Memory Play (TC-WR635S only)	10
Chapter 3 Recording	
Recording (Only on deck B)	12
Adjusting the recording level	13
Recording FM broadcasts with the Dolby NR system ...	13
What is the Dolby HX PRO system?	14
To protect a recording	14
Making an optimum recording	15
Inserting a blank space during recording	
— Record Muting	16
Chapter 4 Other Operations	
Dubbing a tape	17
Dubbing only desired portions	18
Chapter 5 Additional Information	
Maintenance	19
Cleaning the heads and tape path	19
Demagnetizing the heads	19
Cleaning the cabinet	19
Specifications	20
Troubleshooting guide	21

Chapter 1 Getting Started

Features

For higher quality recording/playback

- **B, C and S (TC-WR635S only) type Dolby NR⁺ systems** which reduce tape noise.
- **The Dolby HX PRO⁺ system** which improves the linearity of the tape's high-range response during recording.
- **Automatic calibration** which ensures optimum recording conditions to bring out the best in every tape.

For your convenience

- **Automatic tape type detection** during playback and recording.
- **A relay function** for long playback.
- **Synchronized dubbing** at normal or high speed.
- **The Multi-AMS and Memory Play (TC-WR635S only) functions** which provide easy access to a desired selection.

For easier operation

- **Twin easy-to read digital counters** which show the elapsed recording or playing time on each deck.

* Dolby noise reduction and HX Pro headroom extension manufactured under license from Dolby Laboratories Licensing Corporation. HX Pro originated by Bang & Olufsen.
"DOLBY", the double-D symbol  and "HX PRO" are trademarks of Dolby Laboratories Licensing Corporation.

Differences between the models

This instruction manual covers the TC-WR635S and TC-WR535. The TC-WR635S has the following features which are not found in the TC-WR535.

- The Dolby S NR system
- Memory Play function

Note: All illustrations in this manual show the TC-WR635S.

Precautions

On safety

- Should any solid object or liquid fall into the cabinet, unplug the unit and have it checked by qualified personnel before operating it any further.
- Unplug the unit from the wall outlet if it will not be used for a long time. To disconnect the cord, pull it out by grasping the plug. Never pull the cord itself.
- The unit is not disconnected from the AC power source (mains) as long as it is connected to the wall outlet, even if the unit itself has been turned off.

On operation

- When the unit is not used, turn the power off to conserve energy and to extend the useful life of your unit.
- Because of a safety mechanism, the function buttons will not operate if the cassette holder is not completely closed, if there is no cassette in the cassette holder, or if a cassette has been incorrectly inserted into the cassette holder.

On head cleaning

The head and tape path should be cleaned after every ten hours of operation. Dirty heads and a dirty tape path may cause:

- loss of high-frequency response
- loss of sound volume
- sound drop-out

If you have any questions or problems concerning your unit, please contact your nearest Sony dealer.

For the customers in the U. S. A.

For detailed safety precautions, see the leaflet "IMPORTANT SAFEGUARDS".

Unpacking

Checking the Supplied Accessories

Make sure that the following supplied accessories are included with your unit.

- Audio connecting cords (2)

Notes on Installation

- Place the unit with the front panel facing you in a location with adequate air circulation to prevent overheating of the unit.
- Do not place the unit:
 - near heat sources such as radiators or air ducts.
 - in places subject to direct sunlight, excessive dust, mechanical vibration or shock.
 - in an inclined position.
 - on a rug or other soft surfaces that would block the ventilation holes on the bottom of the unit.

Do not throw away the carton and the packing material They will come in handy when transporting the unit or shipping it for servicing.

Checking the Operating Voltage

- Operate the unit only on 120 V AC, 60 Hz (U.S.A. and Canada model) or 240 V AC, 50 Hz (U.K. model).
- Before operating the unit, be sure that the operating voltage of your unit is identical with that of your local power supply.

Hooking Up the System

Before You Begin

- Turn off the power to all equipment to be connected before making any connection.
- Note that the red plug of the supplied connecting cord is for right-channel (R) connection and the white plug for left-channel (L) connection.
- The connecting cords should be fully inserted into the jacks. A loose connection may cause hum pickup.

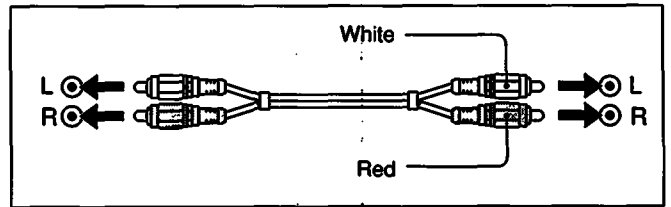

Hook-up Example

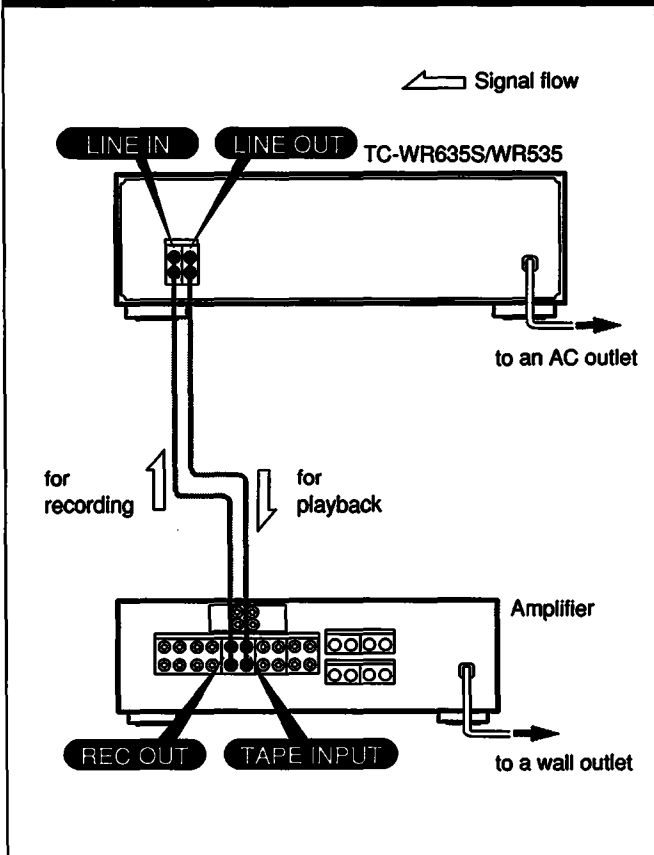

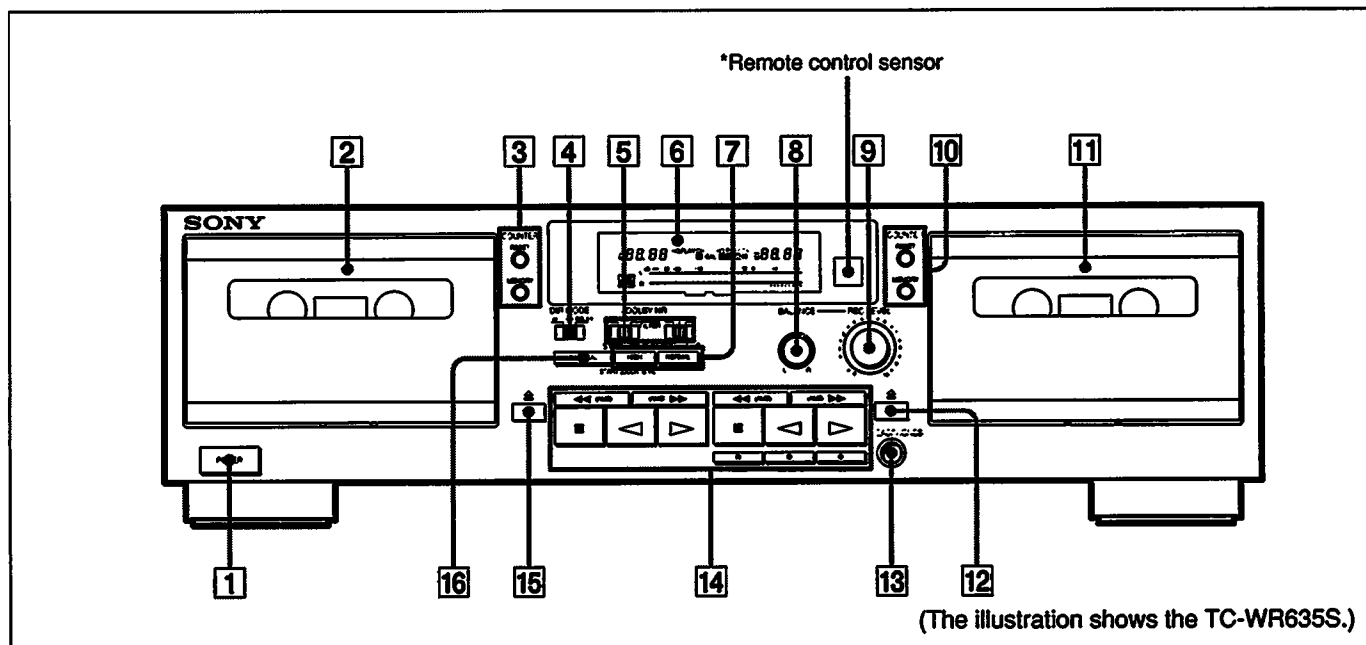

Identifying the Parts

Front Panel



For details, refer to the page number(s) indicated in parentheses.

- | | |
|---|--|
| <p>1 POWER switch</p> <p>2 Deck A</p> <p>3 COUNTER buttons (deck A) (page 10)
RESET button
MEMORY button (TC-WR635S only)</p> <p>4 DIR (direction) MODE switch (pages 7, 8, 12 and 17)</p> <p>5 DOLBY NR (Dolby noise reduction) switches
OFF/ON/FILTER ON switch
B/C switch (TC-WR535)
B/C/S switch (TC-WR635S) (pages 7, 12 and 13)</p> <p>6 Display panel</p> <p>7 SYNCHRO DUBBING buttons (page 17)
HIGH button
NORMAL button</p> <p>8 BALANCE control (page 12)</p> <p>9 REC (recording) LEVEL control (pages 12 and 13)</p> <p>10 COUNTER buttons (deck B) (page 10)
RESET button
MEMORY button (TC-WR635S only)</p> <p>11 Deck B</p> <p>12 ▲ (eject) button (deck B)</p> | <p>13 HEADPHONES jack (stereo phone jack)</p> <p>14 Tape operation buttons
◀◀ (leftward fast winding) (Multi-AMS**) button
▶▶ (rightward fast winding) (Multi-AMS**) button
■ (stop) button
◀ (reverse play) button
▶ (forward play) button
 PAUSE button (deck B only)
○ REC MUTE (record muting) button (deck B only) (page 16)
● REC (recording) button (deck B only)</p> <p>15 ▲ (eject) button (deck A)</p> <p>16 AUTO CAL button (page 15)</p> <p>*Remote control sensor
You can remotely control this cassette deck with:
— A remote commander that came with a Sony amplifier or receiver if it has the  mark and cassette deck control capability.
— Any optional Sony remote commander with the  mark and cassette deck control capability.</p> <p>** AMS is an abbreviation for Automatic Music Sensor.</p> |
|---|--|

Playing Back

Follow the procedure below to play back a cassette on deck A or B.

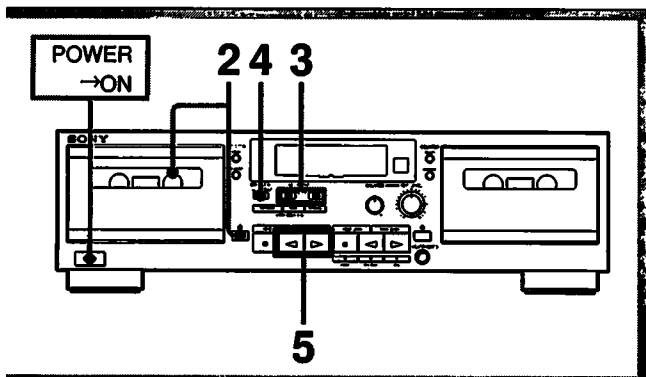

1 Turn on the amplifier and select the tape function.

2 Insert a cassette.

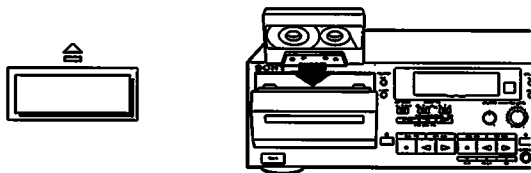

3 Set DOLBY NR to the same position that was used when the cassette was recorded.

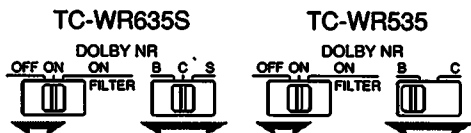

4 Set DIR MODE.

To play back to the end of one side only	
To play back both sides continuously*	

* After playing back five times, the deck automatically stops.

5 Press ◀ or ▶ to start playback.

To play back from the front side, press ▶.

To play back from the reverse side, press ◀.

The tape direction lights up to show the side you are listening.

To stop playback, press the ■ button.

To stop playback momentarily, press the ||| button (only on deck B).

To restart play, press the |||, ◀ or ▶ button.

To fastwind a tape rightward, press the ▶▶ button in stop mode.

To fastwind a tape leftward, press the ◀◀ button in stop mode.

Is it necessary to set the tape type being used?

No. The deck has an automatic tape type detection system.

To change to recording mode during playback

Keeping the ◀ or ▶ button pressed, press the ● button.

The unit immediately switches from playback to recording without stopping the tape. This is useful when editing previously recorded material.

When decks A and B are in playback mode

Only playback from deck A will be audible.

What is the Dolby NR system?

The Dolby NR (noise reduction) system reduces tape hiss noise in low-level, high-frequency signals by boosting the signals during recording and lowering them during playback. The Dolby S NR system provides the highest reduction in tape hiss noise in both low and high frequencies (TC-WR635S only).

Note

The Dolby HX PRO system is effective only during recording, not during playback.

Playing Back Both Decks in Succession — Relay Play

The Relay Play function plays back cassettes in deck A and deck B continuously and in consecutive order.

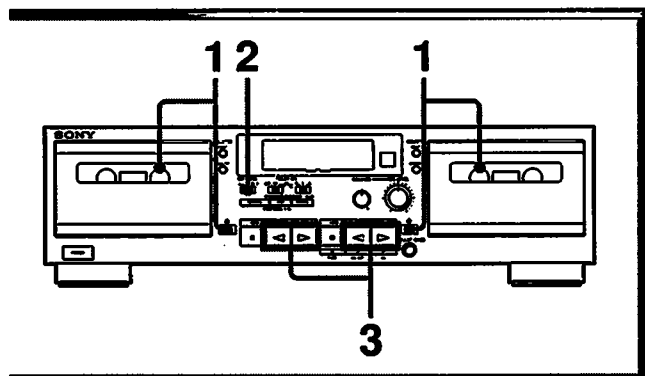

1 Insert cassettes into both decks.

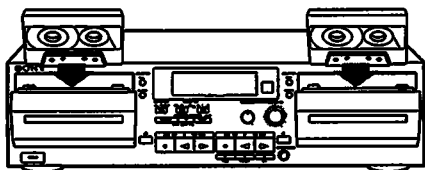

2 Set DIR MODE to RELAY.



3 Press ◀ or ▶ to start playback of the cassette to be listened to first.

To play back from the front side, press ▶.

To play back from the reverse side, press ◀.

Playback sequence of Relay Play

Relay Play always follows the sequence below regardless of where playback starts.

After playing back five times, Relay Play automatically stops.

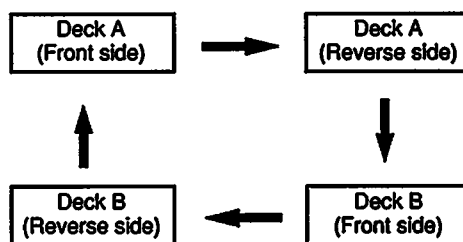

Playing back more than two cassettes in succession

Replacing cassettes that have finished playing with new ones allows you to play back two or more cassettes alternately on each deck.

To stop Relay Play

Press the ■ button of the deck playing.

Locating a Selection — Multi-AMS (Automatic Music Sensor)

By detecting the blank space between selections, the Multi-AMS function allows you to skip up to 30 selections during fast forwarding or reversing to locate the beginning of a selection.

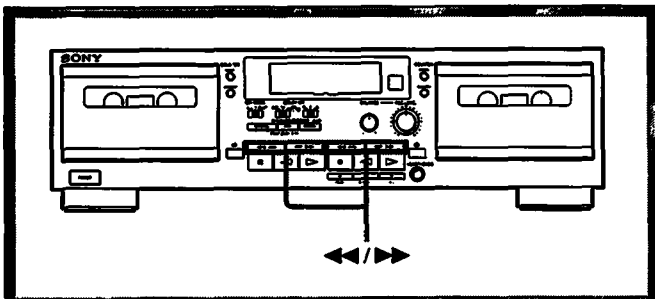

During playback, press ◀◀ or ▶▶ as many times as the number of selections to be skipped.

Playback direction indicator	To locate a selection after the current one	To locate a selection before the current one*
▶	▶▶	◀◀
◀	◀◀	▶▶

* Pressing ◀◀ or ▶▶ once locates the beginning of the current selection.

Tape direction indicator: ▷

↓ : Beginning of selection

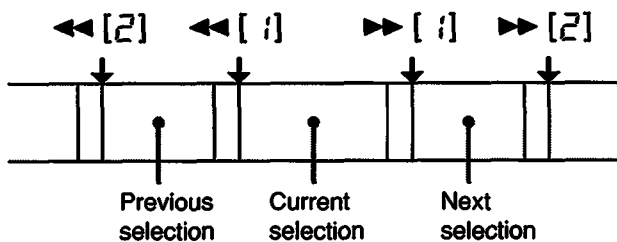

- The number of selections to be skipped, which replaces the counter indication, decreases by one each time a blank space is detected.
- The PLAY indicator flashes during Multi-AMS operation.
- When the beginning of the desired selection is reached, the counter indication returns and playback automatically restarts.

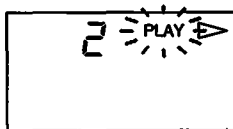

Modifying the indicated number of selections to be skipped

The number of selections to be skipped may be modified by pressing the ◀◀ or ▶▶ button at any time, even during Multi-AMS operation.

Regarding changes in the indicated number

The indicated number of selections to be skipped may change even as it is being set due to the detection of blank spaces during fastwinding of the unit.

The Multi-AMS may skip a selection in the following cases:

- If the ▶▶ (or ◀◀) button is pressed immediately before the following selection.
- If there is noise in the space between selections.
- If the space is less than four seconds long.

The Multi-AMS will treat the following as blanks:

- a long pause in the music
- a passage of low frequencies or very low volume
- a gradual increase or decrease in volume

The Multi-AMS does not function on both decks simultaneously

The Multi-AMS is disabled on one deck whenever the other deck is in playback or pause mode (with the exception of recording pause mode).

Note

Even if the DIR MODE switch is set to ⇄, the Multi-AMS function does not extend to the other side, but stops when the first side comes to an end.

Playing Back Automatically After Rewinding — Auto Play

The Auto Play function automatically starts playing back a cassette after fast winding it to the beginning.

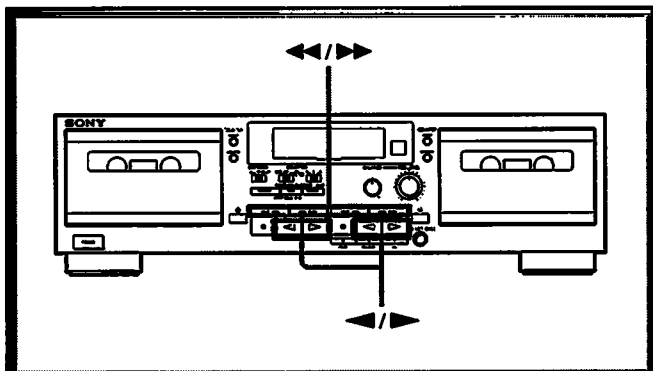

While pressing ► or ◀, press ◀◀ or ►►.

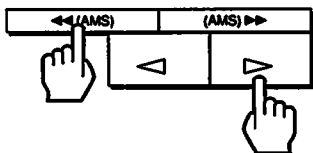

From the beginning of...	While pressing...
front side	►, press ◀◀.
reverse side	◀, press ►►.

Locating a Desired Position Using the Counter — Memory Play (TC-WR635S Only)

The Memory Play function allows you to use the counter to record a desired position on a cassette for fast relocation and automatic playback later.

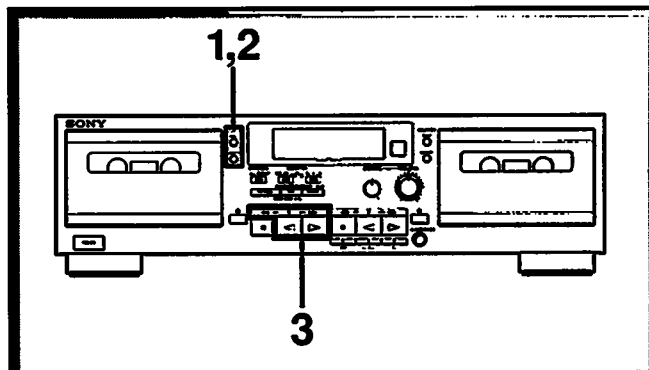

- 1** Press MEMORY to activate the Memory Play function of the deck to be used.

MEMORY

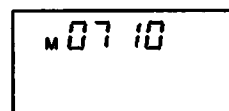

- 2** Press RESET to reset the counter at the desired position. The desired position is memorized.

RESET



- 3** To return to the desired position Check the direction indicator and press the respective buttons shown below.

Direction Indicator	While pressing...
PLAY ►	►, press ◀◀.
◀ PLAY	◀, press ►►.

Returning to the memorized position in stop mode — Memory Stop

If you press only the ◀◀ or ▶▶ button when the M (memory) indicator is on in the stop mode, the tape rewinds and the unit stops when the counter reaches 0000.

Be sure to first stop playback before activating the Memory Stop function, otherwise the Multi-AMS function will activate.

To deactivate the Memory Play function

Press the MEMORY button, turning off the M (memory) indicator.

Note on Memory Play/Stop

In actuality, the tape is rewound to slightly short of 0000.

Do not turn off the power while using the counter

Turning the power off, then on again resets both counters to 0000.

Recording (Only on Deck B)

Follow this procedure to record a source on a cassette (deck B only).

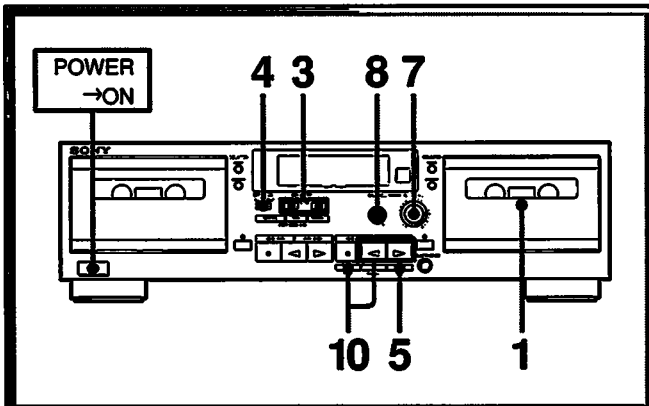

- 1** Insert a cassette into deck B. Wind the tape to the desired starting position if necessary.



- 2** Perform automatic calibration, if desired (see page 15). If not, go to step 3.

- 3** Set DOLBY NR.

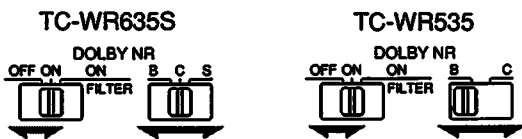

- 4** Select the side(s) to be recorded.

To record on one side	
To record on both sides	

Note
Even at the ⇄ position, recording automatically stops when the tape reaches the end of reverse side.

- 5** Press ● to enter the recording pause mode.

Note

The direction indicator for the side opposite the specified one will flash for three seconds to indicate that recording is possible on that side also. If, however, the tab for that side has been removed to prevent recording, the indicator will not flash.

If the tab has been removed from either side A or B, recording is impossible on the side(s). To record a cassette for recording, cover the respective slot with tape. See "To Protect a Recording" on page 14.



- 6** Play the program source to be recorded.

- 7** Turn REC LEVEL to adjust the recording level.

See "Adjusting the Recording Level" on page 13.



- 8** Turn BALANCE to adjust the balance.



- 9** Restart the program source, if required.

10 Start recording.

To record on the front side of the cassette	
When ▷ is on	Press ▶ once or .
When ◁ is on	Press ▶ twice.

To record on the reverse side of the cassette	
When ◁ is on	Press ◀ once or .
When ▷ is on	Press ◀ twice.

Note

Pressing ◀ or ▶ twice will cause the unit first to change tape direction and then start recording in that direction.

To stop recording
Press the ■ button.

Adjusting the Recording Level

The optimum recording level, which differs according to the tape type, is indicated on the PEAK LEVEL METER for each tape type.

Adjust the REC LEVEL control as high as possible without exceeding the recommended range for the tape type being used.

PEAK LEVEL METER readings by tape type

Recommended maximum PEAK LEVEL METER readings.

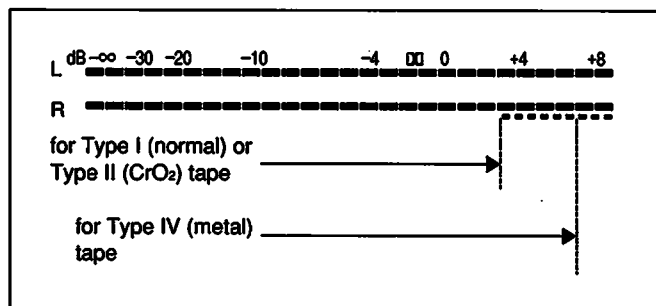

Tips on recording level adjustment

Setting the recording level too low will produce a hissing sound, while setting it too high will produce distortion. Generally, the optimum recording level for high and low frequencies is lower than that for middle frequencies. Therefore, when recording program sources with many high and low frequencies, you should set the level to a relatively low position. For even better results, check the recording results with your own ears.

Recording FM Broadcasts With the Dolby NR System

When recording FM broadcasts with Dolby NR system, set the respective DOLBY NR switch to FILTER ON. The multiplex filter eliminates remnants of the 19 kHz stereo carrier and 38 kHz subcarrier signals which may impair the operation of the Dolby NR system. Be sure to set the respective DOLBY NR switch to FILTER ON when using the Dolby NR system. During recording with the Dolby NR system, use this switch only if the tuner is not equipped with its own multiplex filter or the equipped filter does not function effectively.

Recording (Only on Deck B)

What is the Dolby HX PRO System?

The Dolby HX PRO system provides linearity in high-range frequency response during recording. Tapes recorded with this system retain the same high quality even when played back on other tape decks.

As shown below, characteristics such as output level and distortion differ widely according to the bias (high-frequency) current.

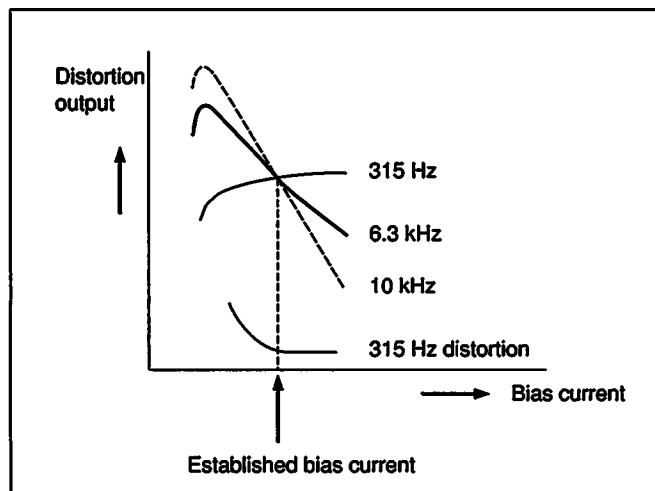

In conventional systems (see diagram below), the bias current is susceptible to variations in certain recording signals which may cause fluctuations in frequency response, distortion, or other unwanted characteristics.

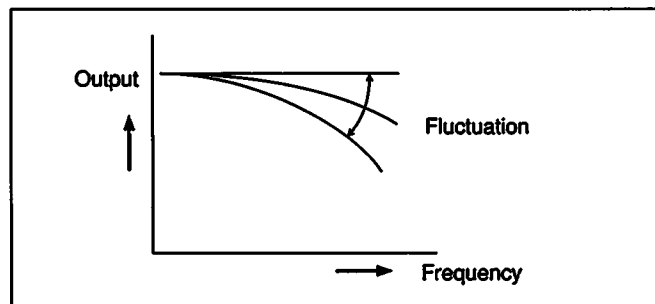

With the Dolby HX PRO system, the effective bias amount added to the bias current is controlled in millisecond units to greatly reduce distortion, improving linearity in high-range response and ensuring high-intensity recording with minimal distortion and noise.

To Protect a Recording

To protect a recording on side A or B
Break out the respective tab.

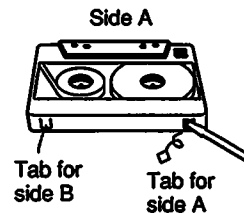

To recover a cassette for recording
Cover the respective slot with tape.

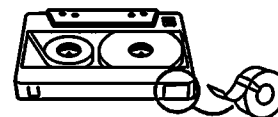

When using Type II (CrO₂) or Type IV (metal) cassettes
Be careful not to cover the detector slots which are necessary for automatic tape type detection.

Type II (CrO₂) cassette

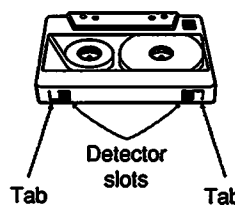

Type IV (metal) cassette

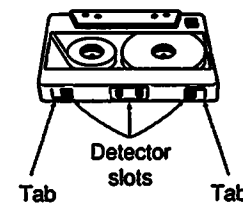

Cassette Care

- Avoid touching the tape surface of a cassette to prevent contamination of the heads by dirt, dust, or oil on the skin.
- Keep cassettes away from equipment with magnets, such as speakers and amplifiers, as erasure or distortion of the recorded tape could occur.
- Do not expose cassettes to direct sunlight, extremely cold temperatures, or moisture.

Note on cassettes longer than 90 minutes

The use of cassettes longer than 90 minutes is not recommended except for long continuous playback.

Making an Optimum Recording

Cassettes are available in several types, each with varying magnetic properties. In addition to the Automatic Tape Selection (ATS) system which sets the appropriate equalization characteristics, bias current and recording level for each tape type, the automatic calibration function can be used to obtain more optimum recording conditions for your tape, especially in conjunction with the Dolby NR system.

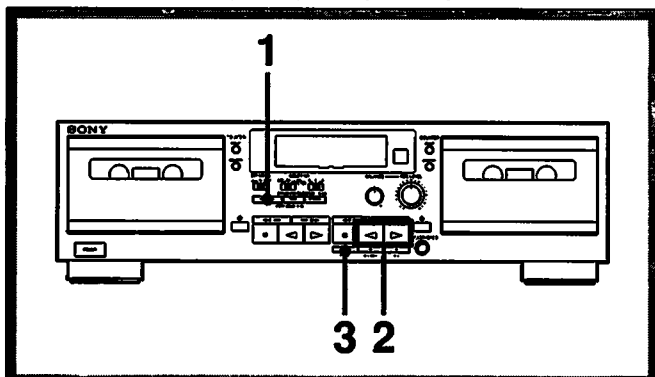

1 Press AUTO CAL.

The CAL indicator on the display panel lights up, CAL appears on the counter and the unit enters recording pause mode.

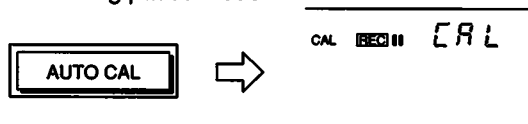

2 Press ► or ◀ to select the side to be recorded.

To select the front side, press ►.
To select the reverse side, press ◀.

See "If the cassette is record protected" on this page.

3 Press ■.

The unit fastwinds a short distance, the counter begins counting down from 9 to 0 and the unit performs recording, rewinding and playback as part of the calibration process.

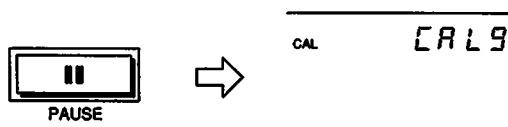

After automatic calibration is completed, the tape rewinds to the original position, the counter returns to normal and the unit enters stop mode.

4 Continue with step 3 on page 12 to record a source.

To cancel the automatic calibration function
Press the ■ button.

Notes on recalibration

As long as the unit remains on, all generated calibration data are saved and applied by the system whenever a cassette of the same type (I, II or IV) is inserted.

The CAL indicator lights up when previous calibration data are being applied. However, since cassettes of the same type also vary in their characteristics, recalibration is recommended each time a new cassette is inserted.

To recalibrate:

- 1 Insert the new cassette for recording.
The CAL indicator lights up.
- 2 Press AUTO CAL.
The CAL indicator goes off and the previous calibration data for that tape type are temporarily restored.
- 3 Continue from step 1 of the automatic calibration procedure.

Notes

- Since a test tone is recorded on the tape during automatic calibration, previously recorded material is erased where the test tone is recorded.
- Relatively new tape and clean heads are recommended for best calibration results. Excessively worn tape or dirty heads may result in incorrect calibration values.
- All calibration data saved in the system are lost when the unit is turned off.
- The automatic calibration function works only when both decks are stopped.
Playback on deck A is disabled during automatic calibration on deck B.
- It is unnecessary to select the Dolby NR system when performing automatic calibration since the calibration results are the same regardless of the Dolby NR system.

The CAL indicator flashes continuously

The automatic calibration process has been interrupted by:

- The end of the tape. Reverse the tape direction or fastwind to a new position that allows recording of the test tone.
- Damaged tape or dirty heads. Change the cassette or clean and demagnetize the heads.

If the cassette is record protected

- If both tabs have been removed (see page 14), the CAL indicator flashes three times and automatic calibration cannot be performed.
- If only the current side is protected, the direction indicator for the other side flashes and calibration is possible only in that direction.
- If an attempt is made to change from an unprotected to a protected side in step 2, the unit will not respond and automatic calibration is possible only in the current direction.

Inserting a Blank Space During Recording — Record Muting

The Record Muting function allows you to insert a four-second blank or replace unwanted input with a blank of any desired length.

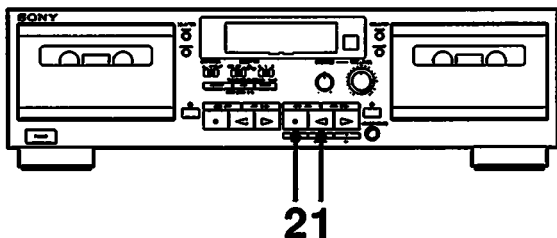

- 1 While recording, press  and release it immediately.**

The REC indicator starts to flash. During this time, no incoming signals are recorded on the tape.





After four seconds, the  indicator lights up and the unit enters recording pause mode.



- 2 Press  to resume recording.**



To create a blank longer than four seconds

Press the  button for the desired length of time. After four seconds, the REC indicator flashes with greater rapidity. When you release the  button, the  indicator lights up and the unit goes into recording pause mode. Press the  button to resume recording.

Dubbing a Tape

Use the dubbing function to copy a tape in deck A to a tape in deck B. High-speed dubbing is convenient for dubbing entire tapes while normal-speed dubbing is handy for tape editing.

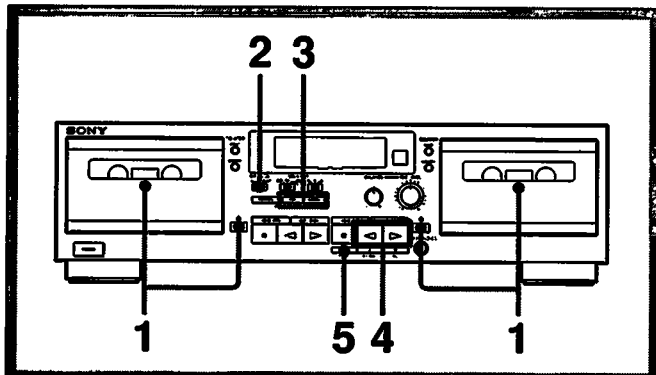

1 Insert cassettes into both tape decks.

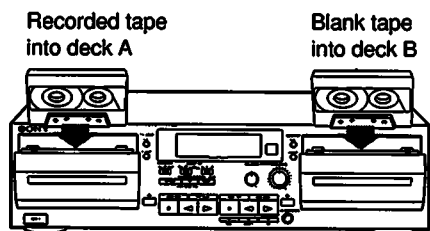

2 Select the direction mode.

One side	
Both sides	<p>Dubbing of the reverse side starts independently of deck A.</p>
	<p>Dubbing of the reverse side starts simultaneously with deck A.</p>

3 Press HIGH or NORMAL to select the dubbing speed.

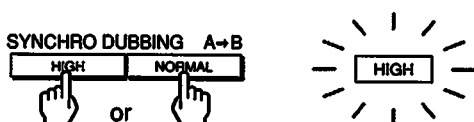

4 Select the side on which to start dubbing.

To dub from the front side, press ►.

To dub from the reverse side, press ◄.

5 Press II on deck B to start dubbing.



To stop dubbing

During normal-speed dubbing, press the ■ button on deck B. During high-speed dubbing, press the ■ button on either deck A or B.

During high-speed dubbing
Only the ■ button is operative.

If the NORM or HIGH speed indicator flashes three times
Either one or both tabs of the cassette inserted into deck B have been removed, making dubbing impossible for that side. Cover the slot(s) with tape (see page 14).

Is it necessary to adjust the recording level and select the Dolby NR system?

It is unnecessary since the tape in deck B is automatically recorded with the same recording level and Dolby noise reduction system as the original in deck A. The Dolby system must, however, be set to match the tape in deck A when the sound is monitored during normal-speed dubbing.

Note on tape dubbing

If the sound is affected by the proximity of a television set during high-speed dubbing, turn the television set off or move it away from the deck.

Dubbing Only Desired Portions

Follow this procedure to dub only desired portions of selections. Note that this is only possible in the normal-speed dubbing mode.

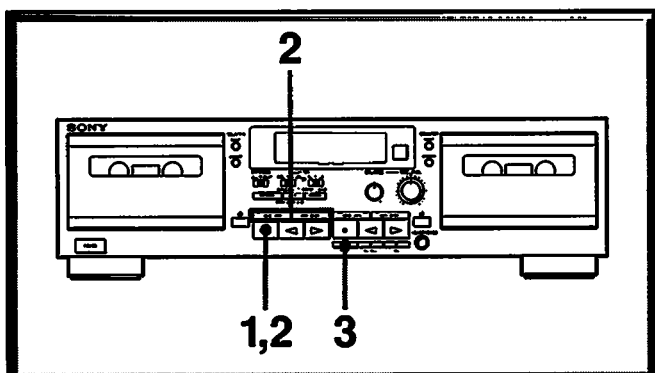

- 1** Press ■ on deck A at the start of a selection to be skipped.

Deck A enters the stop mode and deck B enters the recording pause mode.



- 2** Locate the desired portion on deck A.

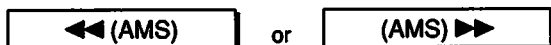

- 3** Press || on deck B to resume dubbing.



PAUSE

Maintenance

Cleaning the Heads and Tape Path

Clean all surfaces over which the tape travels after every ten hours of operation to guard against:

- low-quality sound
- a decrease in sound level
- excessive wow, flutter or drop-out
- incomplete erasure
- impairment of recording function

To obtain high-quality recorded sound, cleaning before every recording is recommended.

- 1 Press \blacktriangle to open the cassette holder. Grasp the front holder on both sides and gently lift to remove it.**
- 2 With the unit turned off, wipe the heads, the pinch rollers and the capstans with a cotton swab slightly moistened with alcohol or a commercially available cleaning fluid for tape decks.**
- 3 Replace the cassette holder.**

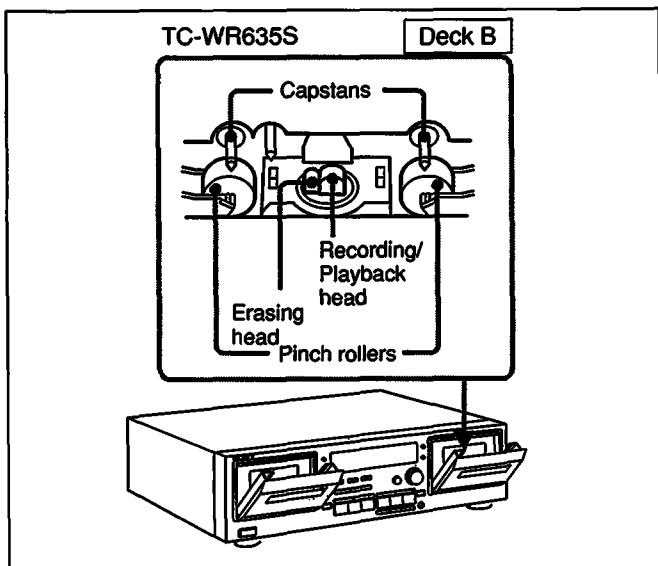

Do not insert a cassette until the cleaned areas are completely dry.

Demagnetizing the Heads

After 20 to 30 hours of use, or when you notice hiss and/or loss of high frequencies, the residual magnetism built up on the heads should be removed.

- 1 Turn off the power.**
- 2 Demagnetize the heads with any commercially available demagnetizer. Refer to the instruction manual of the demagnetizer for detailed instructions.**

Cleaning the Cabinet

Clean the cabinet, panel and controls with a soft cloth slightly moistened with a mild detergent solution.

Do not use any type of abrasive pad, scouring powder or solvents such as alcohol or benzine.

Specifications

Recording system 4-track 2-channel stereo
 Fast winding time Approx. 90 sec. (with Sony C-60 cassette)
 Bias AC bias
 Signal-to-noise ratio (at peak level and weighted)

Cassette (Dolby NR off)	Type IV	Type II	Type I
	58 dB	57 dB	55 dB

S/N ratio improvement (approximate values)
 With Dolby B NR on: 5 dB at 1 kHz; 10 dB at 5 kHz
 With Dolby C NR on: 15 dB at 500 Hz; 20 dB at 1 kHz
 With Dolby S NR on: 10 dB at 100 Hz; 24 dB at 1 kHz (TC-WR635S only)

Harmonic distortion
 0.4% (with Type I, 160 nWb/m, 315 Hz, 3rd H.D.)
 1.8% (with Type IV, 250 nWb/m, 315 Hz, 3rd H.D.)

Frequency response (Dolby NR off)

Cassette Model	Type IV cassette	Type II cassette	Type I cassette
TC-WR635S/ WR535	30 - 18,000 Hz (±3 dB, IEC) 30 - 13,000 Hz [±3 dB (-4 dB) recording]	30 - 17,000 Hz (±3 dB, IEC)	30 - 15,000 Hz (±3 dB, IEC)

Type IV : Sony ES-IV
 Type II : Sony UX-S or UX
 Type I : Sony HF-S

Wow and flutter
 TC-WR535
 ±0.14% W.Peak (IEC)
 0.08% W.RMS (NAB)
 ±0.19% W.Peak (DIN)
 TC-WR635S
 ±0.13% W.Peak (IEC)
 0.07% W.RMS (NAB)
 ±0.18% W.Peak (DIN)

Inputs

Line inputs (phono jacks)	Sensitivity	0.16 V
	Input impedance	47 k ohms

Outputs

Line outputs (phono jacks)	Rated output level	0.5 V at a load impedance of 47 k ohms
	Load impedance	Over 10 k ohms
Headphones (stereo phone jack)	Output level	1 mW at a load impedance of 32 ohms

General

Power requirements Model for U.S.A. and Canada:
120 V AC, 60 Hz
Model for the United Kingdom:
240 V AC, 50/60 Hz

Power consumption 25 W
 Dimensions Approx. 430 × 123 × 310 mm (w/h/d)
 (17 × 4 7/8 × 12 1/4 inches) including projecting parts and controls
 Mass Approx. 4.5 kg (9 lbs 15 oz)

Supplied accessories

Audio connecting cords (2)

Note

This appliance conforms with EEC Directive 87/308 EEC regarding interference suppression.

Design and specifications are subject to change without notice.

Troubleshooting Guide

The following trouble checks will help you correct the most common problems encountered with your tape deck. Should any problems persist after you have made these checks, consult your nearest Sony dealer.

Before proceeding with these trouble checks, verify that:

- The power cord is firmly connected.
- Amplifier connections are firmly made.
- Heads, capstans and pinch rollers are clean.
- The amplifier controls and switches are set correctly.

Function Buttons and Tape Transport Problems

Symptom	Cause	Remedy
The function buttons do not activate.	The cassette holder is not fully closed.	Close the holder completely.
	The cassette is not properly inserted.	Insert cassette correctly.
	Button was pressed immediately after power was turned on.	Wait until the ■■ indicator stops flashing.
The ● button does not activate.	There is no cassette in the holder.	Insert a cassette.
	A tab has been removed from the cassette.	Cover the slot with tape (page 14).
Automatic shut-off mechanism activates before the tape comes to its end.	The tape is slack.	Take up the tape slack.
	The cassette shell is deformed.	Use another cassette.
Excessively loud tape transport noise during fast winding.	This noise is caused by the cassette and does not signify a mechanical problem.	—
The ▲ button does not function.	This occurs when the unit is playing back or recording.	Press the ■ or ■■ button to stop playing back or recording first.

(Continued on next page.)

Troubleshooting Guide

(Continued from previous page.)

Recording and Playback Problems

Symptom	Cause	Remedy
Recording or playback cannot be made or there is a decrease in sound level.	The recording/playback and erasing heads are either dirty or magnetized.	Clean or demagnetize the heads.
	Improper connection.	Make connections properly (page 5).
	Improper setting of the amplifier controls.	Set the amplifier controls to the appropriate positions
Excessive wow, flutter or dropout.	The head, capstan or pinch roller is dirty.	Clean in accordance with instructions (page 19).
Incomplete erasure.	The erasing head is dirty.	Clean the erasing head.
Increased noise or poor reproduction in high frequencies.	The head is magnetized.	Demagnetize the head.
Unbalanced tone in high frequencies.	Improper setting of the DOLBY NR switches.	During playing back, set the switches to the same position used in recording.
	The unit is placed near a television set.	Move the deck away from the television set.
The desired selection cannot be located even if you activate the Multi-AMS.	There is noise in the space between selections.	Rerecord the tape if you can, and insert a blank space of four seconds using the O button.
	The space is less than four seconds long.	
	The ▶▶ (or ◀◀) button was pressed immediately before the beginning of the following selection.	
Playback begins in the middle of a selection when the Multi-AMS function is activated.	The selection contains one of the following: <ul style="list-style-type: none"> — a long pause in the music — a passage of low frequencies or very low volume — a gradual increase or decrease in volume 	While the tape is playing, press the ◀◀ or ▶▶ button again.

Noise

Symptom	Cause	Remedy
Hum noise.	The unit is stacked on or under the amplifier.	Separate the unit.
Noise is recorded.	The recording was made near equipment such as a television set or a color monitor, and interference has affected the recording on the tape and the Dolby NR system.	Move the unit away from the television set or color monitor.