

Picture Tubes 1975/76

6370/3012 E

Components **ITT**

Right to change reserved
Printed in Germany

Picture Tubes 1975/76

ITT Components Group Europe

Standard Elektrik Lorenz AG
Unternehmensgruppe Bauelemente
D-7300 Esslingen
P. O. Box 807 · Fritz-Müller-Strasse 112
Telephone (07 11) 35 14-1 · Telex 7 256 545

Index

Black and White Picture Tubes

Technical Survey

3

Picture Tubes for New Sets

Type	Characteristic	
A 31-19 W	Tension Band	12
A 31-120 W	Tension Band	14
A 31-121 W	Tension Band	14
A 31-191 W	Tension Band	12
A 31-250 W	Tension Band	16
A 31-251 W	Tension Band	16
A 37-110 W	SELBOND®	18
A 44-13 W/3	SELBOND®	20
A 44-13 W/3a	Tension Band	20
A 44-280 W	SELBOND®	24
A 44-281 W	SELBOND®	24
A 51-10 W	SELBOND®	26
A 61-120 W/2	SELBOND®	28

Picture Tubes for Replacements

Type	Characteristic	
AW 17-69	Industrial Television	30
M 17-18 W	Monitor Tube	32
A 28-13 W	Tension Band	34
A 31-15 W	Tension Band	36
A 41-10 W	SELBOND®	38
A 47-27 W/2	SELBOND®	40
A 59-22 W	SELBOND®	42
AW 59-91	Without Steel Reinforcement	44
A 65-13 W	SELBOND®	46

Colour Picture Tubes

Technical Survey

49

Picture Tubes for New Sets

Type	Characteristic	
A 66-120 X	Shadow Mask Tube	70
A 66-140 X	Shadow Mask Tube	74
A 66-410 X	Shadow Mask Tube	74
A 67-150 X	Shadow Mask Tube	78
A 67-510 X	Shadow Mask Tube	78

Picture Tubes for Replacements

Type	Characteristic	
A 55-14 X	Shadow Mask Tube	82
A 56-120 X	Shadow Mask Tube	86
A 63-11 X	Shadow Mask Tube	90
A 63-200 X	Shadow Mask Tube	90

Black and White Picture Tubes

Technical Survey

1. General Hints on the Handling of Black and White Tubes

1.1 Hazards

A television picture tube is basically a thick-walled evacuated bulb. To operate the tube, a high tension is required for the anode and the metal coating on the inner surface of the screen. This involves some hazards, described briefly below:

When the bulb is broken, glass will fly in all directions with tremendous force. This is called an implosion and is described in more detail in together with the respective safety procedures under chapter 2.

The high-voltage smoothing capacitor formed by the inner aluminium coating and the external graphite coating will remain charged for a considerable time even after the tube has been switched off. In order to avoid an electrical shock if the anode contact is accidentally touched, it is recommended to discharge the anode contact and the external conductive coating by means of a grounded shorting strap before work is started on the equipment and the tube.

A dangerous X-ray hazard does not exist when the equipment is properly operated. It is true that during the operation of the tube weak X-ray and ultraviolet radiation is excited inside the tube, but most of this radiation is converted into visible light and heat on the screen. Moreover, the thick faceplate absorbs a considerable portion of the remaining radiation. Measurements have shown that a picture tube in operation produces only about 1/40 of the background radiation acting on the human organism. The X-ray energy produced by the tube is indeed less than that produced by the luminous dial of a wrist watch. Any fear of a detrimental effect of the radiation on the health of the viewer is absolutely unfounded.

1.2 Packing

When handling large tubes (heavy weight), it must be borne in mind that the bulb can be damaged by blows and scratches. The bulb is of a high pressure resistant design, so not every scratch will result in the immediate destruction of the tube, though it may reduce the thermal and mechanical strength of the bulb. Also, damages to the faceplate (screen) will be detrimental to picture quality. For this reason the ITT packing for picture tubes is so designed that damage to the bulb during packing, unpacking, storage and transport is impossible. Considering weight and volume, of large television picture tubes in particular, manual handling is only possible in single unit packing. Preferred for transporting large quantities is bulk packing, which can only be moved on pallets by means of fork lifts.

1.3 Storage and transport

Normally the picture tubes are stored and transported packed in cartons. For handling unpacked tubes, special racks or transport carts with individual tube holders are used. High stacks of cartons are subdivided on pallets, which give the stack a firm stand and enable fork trucks to be used. Pallets are also employed for truck and rail transport.

1.4 Installation and removal

When installing or removing a tube, care should be taken not to damage the fragile bulb. Grasp the tube diagonally, so that the weight is approximately balanced and the tube neck can always be seen. Do not pick up a picture tube by the neck, since the glass is very thin at this point and breaks easily.

When placing the tube face down on a level surface, rest it on a support with four soft projections. When the tube is

Black and White Picture Tubes

Technical Survey

placed down on the panel skirt, the neck has to be supported separately to prevent damage to the base pins or to the tubulation.

The picture tube is installed in the television receiver with the screen in a vertical position. This is normally achieved by a resilient rubber tape slipped over the panel skirt or by an elastic tightening strap with a soft intermediate layer to prevent the contacting glass surfaces from being scratched. When installing the tube make sure that the pressure is distributed uniformly over the supporting area and that it is not excessive.

Steel band reinforced picture tubes are bolted in place by means of the mounting lugs. The deflection yoke is slipped over the tube neck and must sit against the funnel. The deflection yoke is not provided for supporting the tube. The socket provided with flexible leads is also plugged into the tube base and is supported by it. Finally the high tension lead is connected to the anode contact.

1.5 Thermal stress

All parts of the tube are subjected to higher thermal stresses during manufacture than those encountered during normal operation. The tube withstands these stresses without damage, since heating and cooling is performed within a well proven and automatically controlled temperature cycle. The tube is designed to operate under both extreme arctic and tropical conditions. However cracks may occur when the tube is not operated properly, in particular in the case of excessive local temperature differences.

1.6 Contamination

When the tube is brought from a cold room into a heated room, the water vapour in the air will condense on the cold surfaces, which may result in leakage currents or flashovers at the tube base

or the anode contact. The anode area is protected against humidity by water-repellent paint, which ensures a high degree of resistance against flashovers. In spite of this it is recommended to switch the tube on only after the temperature is approximately at equilibrium.

When the picture tube has been in use for a longer period of time, dust will settle on the surfaces of the tube due to electrostatic charges. Together with the humidity mentioned above the dust forms a film on the glass surfaces, which may likewise result in leakage currents and flashovers. On the screen it will also lower picture quality. On the neck it reduces heat radiation, thus causing considerable temperature differences, especially in the glass. Therefore we recommend cleaning the tube at regular intervals or whenever the need arises, together with the receiver if possible.

1.7 Functional troubles

The highly automated production process with many intermediate inspections and a 100% final test by means of automatic test equipment ensure trouble-free operation and long life for ITT picture tubes. If, in spite of this, a tube should fail due to a material or manufacturing defect, replacement will be made free of charge during the first 12 months of service.

The life of a tube ends when, after several thousand hours of operation, there is a marked decrease in the cathode emission together with a reduction in the sharpness and brightness of the picture.

2. Implosion Protection

2.1 Purpose of the implosion protection

Since the television picture tubes are evacuated, a high pressure takes effect upon the bulb. The weight acting on an area of the bulb with a diameter of approx. 50 cm (19³/₄"") amounts to 2 tons. This extreme pressure has already been taken into consideration during manufacture through special precautions. Those parts of the bulb subject to very high stresses are provided with thicker walls. This prevents the bulb from being destroyed under normal conditions. In some isolated cases however — whether due to improper handling or adverse external influences — the bulb may be damaged. Fine fissures or checks as may be caused by shock or impact will then eventually result in the destruction of the picture tube due to the high difference in pressure. This is called an implosion, and the glass will fly in all directions with tremendous force. An **implosion** is the inward collapse of an evacuated container due to a sudden compensation of the pressure difference. From the above it is seen that a gradual compensation of pressure caused by a fine crack in the glass is not an implosion. Based on this concept, numerous techniques have been developed, all serving the same purpose, namely to prevent an implosion caused by defects in the glass and to protect the viewer and technician from the effects of such a sudden destruction of the bulb.

VDE Standard (Association of German Electrical Engineers) 0868, containing general specifications for implosion-protected picture tubes, has been in force in Germany since Juli 1, 1963. This standard is binding for all German picture tube manufacturers. The basic requirement of this standard is that **implosion-protected picture tubes** must be designed and rated so that implosion is impossible

with **proper tube handling** and, hence, no hazard will exist for the user and the surroundings.

2.2 Implosion protection according to the SELBOND[®] method

One method of obtaining implosion-proof picture tubes is the SELBOND implosion protection method developed by SEL (see illustration 1). With this method the mechanical stresses required for partial compensation of the strains within the glass are not obtained by means of a shrinking process, but by direct mechanical pressure on the critical zones of the bulb. The frame is fitted around the bulb with a high pre-tension. It is in direct contact with the glass and is given mechanical support by a sealing and filling material filled in between the SELBOND frame and the bulb.

This method ensures a high degree of protection against implosion.

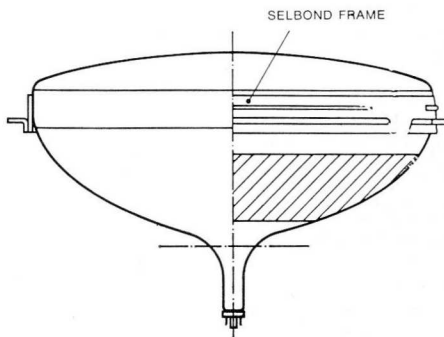

Figure 1: Implosion protection according to the SELBOND[®] method

Black and White Picture Tubes

Technical Survey

3. Symbols for the Quantities Listed Under Technical Data

(Example for Tetrode With Einzel-Lens)

3.1 Typical Operating Conditions

Heater	
Heater Voltage	U_f
Heater Current	I_f
Anode	
Voltage	U_{g3g5a}
Screen Grid	
Voltage	U_{g2}
Grid-No. 4	
Focusing Voltage	U_{g4}
Control Grid	
Cutoff Voltage	$(-U_{g1})_{\text{cutoff}}$
Cathode	
Cutoff Voltage	$U_{k \text{ cutoff}}$

3.2 Maximum Ratings

Anode	
Voltage	U_{g3g5a}
Current	I_{g3g5a}
Current-Limiting Resistance	R_{g3g5a}
Screen Grid	
Voltage	U_{g2}
Current-Limiting Resistance	R_{g2}
Grid-No. 4	
Focusing Voltage	U_{g4}
Peak Voltage	$U_{g4 \text{ s}}$
Current-Limiting Resistance	R_{g4}
Control Grid	
Bias Voltage	U_{g1}
Peak Control Voltage	$U_{g1 \text{ p}}$
Maximum Grid Leakage Resistance	$R_{g1 \text{ max}}$
Grid Leakage	
Impedance (at 50 Hz)	Z_{g1}
Control Grid Current-Limiting Resistance	$R_{g1 \text{ min}}$

Cathode	
Voltage	U_k
Grid Leakage Resistance	$R_{k/g1}$
Impedance (at 50 Hz)	$Z_{k/g1}$
Peak Voltage	$U_{k \text{ p}}$
Screen	
Screen Dissipation Load	P_{1m}
Heater/Cathode	
Voltage	
Heater —	
During Warm-Up Period	$U_{\pm f/k (1)}$
Heater —	
After Warm-Up Period	$U_{\pm f/k (2)}$
Heater —	
Peak Voltage After Warm-Up Period	$U_{\pm f/k \text{ s}}$
Resistance	
External Resistance	$R_{f/k}$
External	
Impedance (at 50 Hz)	$Z_{f/k}$
3.3 Ratings for Circuit Design	
Leakage Current	I_{g2}
Leakage Current	I_{g4}
Leakage Resistance	$R_{m/m'}$

3.4 Capacitances

Control Grid to All Other Electrodes	C_{g1}
Cathode to All Other Electrodes	C_k
Anode to External Conductive Coating	$C_{g3g5a/m}$
Anode to Metal Frame	$C_{g3g5a/m}$

4. Characteristic Data of Black and White Picture Tubes

4.1 Assembly

With similar types of picture tubes the higher number behind the hyphen indicates the latest development step.

The reference line is determined by the designated plane of the reference line gauge when it is seated against the funnel of the bulb.

Depending on the geographical situation, the earth's magnetic field may cause a central spot deviation. The raster displacement may amount to 2 mm ($5/64''$) max. The tube base may be within the designated tolerance circle with reference to the vertical line through the centre of the screen.

The tube is provided with a ring-shaped graphite coating. The designated field indicates the section provided for the grounding spring.

The metal frame is insulated from the ring-shaped graphite coating. The bare metal mounting lugs may be used for grounding the steel frame.

4.2 Operating data

Operating values other than those quoted are not permitted. For special uses, write for additional information.

The operating values are the mean values of new picture tubes. All electrode voltages refer to cathode potential.

The oxide-coated cathode is of the indirectly heated type. Both alternating current and direct current may be used, with parallel or series connection.

The cutoff voltage is defined by the visual extinction of the focused raster. The undeflected spot disappears only by making the control grid voltage approx. 5 V more negative. This adjustment can easily cause damage to the screen. Therefore the raster measurement method is to be preferred.

The focusing voltage corresponds to the optimum overall focus. The voltage value

to be set depends on the deflection yoke used and the beam current. For optimum focus at the centre of the screen the voltage value is normally 50 to 200 V lower. The external coating of the tube is to be connected to the negative high voltage terminal.

4.3 Maximum ratings

With series connection of the heater the heating voltage must not exceed 9,5 V during warm-up period.

The maximum permissible deviation of the heating currents is $\pm 6\%$ from the nominal value of 0,3 A.

The maximum permissible deviation of the heating voltage is $\pm 10\%$ from the nominal value.

Unless stated otherwise, the standardized warm-up time applies for all picture tubes. With regard to picture distortion, the interference introduced by the heater circuit should be kept at the lowest possible value. Therefore the alternating voltage between heater and cathode should not exceed the value $U_{f/k \text{ rms}} = 20 \text{ V}$.

The circuit for generating the operating voltage must be so rated that the continuous current value at short-circuit is less than 5 mA.

If the peak value of the short-circuit current is equal to or higher than 1 A, or if a charge of 250 μC or more is stored in the voltage source, the protective resistances indicated in the data sheets should be inserted between the individual electrodes and the filter capacitor of the operating voltage source.

The maximum permissible current at grid-No. 4 may be 25 μA .

The maximum negative voltage required for focusing will not exceed 100 V.

When the anode voltage decreases below its permissible minimum value, dark screen areas may be produced, since the velocity

Black and White Picture Tubes

Technical Survey

of electrons is decreased by the aluminium coating. With decreasing anode voltage the picture sharpness diminishes.

The high field strengths in the tube neck may cause fluorescence on the glass wall. However this is insignificant on the vacuum or the life of the tube.

4.4 Notes

4.41 On the technical data

- ① For cathode drive service.
Unless otherwise specified, voltage values refer to grid-No. 1 potential.
- ② Standardized warm-up period.
Parallel or series connection.
With series connection of the heater, the heater voltage must not exceed 9.5 V during warm-up period.
- ③ The focusing voltage is set for optimum overall focus, and depends on beam current and on the deflection yoke used. For optimum focus in the centre of the screen the voltage is about 50 to 200 V lower.
- ④ The cutoff voltage is determined by the visual extinction of the raster.
- ⑤ For $I_{g3g5a} = 0$.
- ⑥ When the anode voltage falls below its minimum permissible value, dark screen areas may be produced, since the velocity of electrons is decreased by the aluminium coating. With decreasing anode voltage the sharpness of the picture diminishes.
- ⑦ Tentative ratings.
- ⑧ Maximum duration 1.5 ms.
- ⑨ In order to avoid picture distortion, the interference caused by the heater circuit should be kept at the lowest possible value. Therefore the alternating voltage between heater and cathode must not exceed $20 V_{rms}$.
- ⑩ During warm-up period, not exceeding 15 seconds, $U_{-f/k \max}$ may increase to 410 V; within 15 and 45 seconds this

value must decrease at least gradually to 250 V.

- ⑪ With separate transformer.
- ⑫ With series connection.
- ⑬ The voltage required for focusing will not be below $-100 V$.
- ⑭ With mains supply $\pm 15\%$.
With stabilized supply or with filament supply from the scanning transformer $\pm 10\%$. With battery operation see characteristic paragraph 4.5.
- ⑮ The screen grid voltage U_{g2} is set in such a manner that at a cathode voltage $U_{k \text{ cutoff}} = 45 V$ a focused raster will disappear. For visual extinction of focused spot the voltage $U_{k \text{ cutoff}}$ is to increase by approx. 5 V.
- ⑯ By using a quick heating cathode the picture will appear in approx. 5 s, when applying a constant heater voltage.

4.42 On the dimensional drawings

- ① Anode cavity cap 7, 92 according to DIN 41 543 (JEDEC No. J 1-21).
- ② The reference line is determined by the designated plane of the reference line gauge, if the gauge is seated against the funnel.
- ③ This area is free of external conductive coating and must be kept clean.
- ④ The tube base will fall within a tolerance circle of max. 45 mm ($1\frac{49}{64}$ " diameter, with respect to the tube axis. The socket should not be rigidly mounted but must be connected by flexible leads.
To avoid cracked stems, only those sockets are allowed which cannot perform a point of contact with the pin closer than 2 mm to the base bottom.
- ⑤ The tube has an external conductive coating. The indicated field denotes the section provided for the connecting springs. The external conductive coating of the tube must be connected with the negative high voltage terminal.

Black and White Picture Tubes

Technical Survey

- ⑥ Dimensions of the bulb, measured at the front edge of the implosion protection.
- ⑦ Nominal dimensions for the position of the mounting bolts. For the bolts a free passage of at least 4,0 mm ($5/32''$) diameter is guaranteed in normal mounting position.
- ⑧ Nominal dimensions of the mounting bolts. For the bolts a free passage of at least 5,7 mm ($15/64''$) diameter is guaranteed in normal mounting position.
- ⑨ Nominal dimensions of the mounting bolts. For the bolts a free passage of at least 7,0 mm ($17/64''$) diameter is guaranteed in normal mounting position.
- ⑩ Nominal dimensions of the mounting bolts. For the bolts a free passage of at least 7,5 mm ($19/64''$) diameter is guaranteed in normal mounting position.
- ⑪ Nominal dimensions of the mounting bolts. For the bolts a free passage of at least 8,0 mm ($5/16''$) diameter is guaranteed in normal mounting position.
- ⑫ Nominal dimensions of the mounting bolts. For the bolts a free passage of at least 8,5 mm ($11/32''$) diameter is guaranteed in normal mounting position.
- ⑬ Nominal dimensions of the mounting bolts. For the bolts a free passage of at least 9,5 mm ($3/8''$) diameter is guaranteed in normal mounting position.
- ⑭ Tolerance range of the mounting lug.
- ⑮ The bare metal mounting lugs may be used for grounding the metal frame. Metal frame and external coating are galvanically separated against each other. They may be connected mutually if it is allowed by the effective safety rules. The impedance between metal frame and external coating must not exceed 1 M Ω at 50 Hz and 5 k Ω at 15 kHz.
- ⑯ The maximum deviation between one screenside angle-seating and a plane through the other three angle-seatings will not exceed 2 mm ($5/64''$).
- ⑰ The Z points are reference points for the vertical position of the X and Y points.
The dimensions for the position of the X, Y and Z points count also for the border line of the minimum useful screen area.
- ⑱ Angular deviation between the anode cavity cap and a plane through the base pins.
- ⑲ Range of validity for the bending radius drawn in this section.
- ⑳ Distance of the faceplate of control grid to the reference line.

4.5 Specifications for A 28-13 W, A 31-19 W, A 31-120 W and A 31-250 W

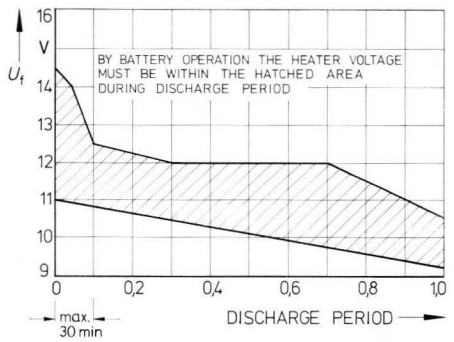

Heater voltage for battery operation.

Black and White Picture Tubes

Technical Survey

4.6 Reference line gauges

Reference line gauge
L 1 DIN 41541
deflection angle 70°
neck diameter 36,5 mm

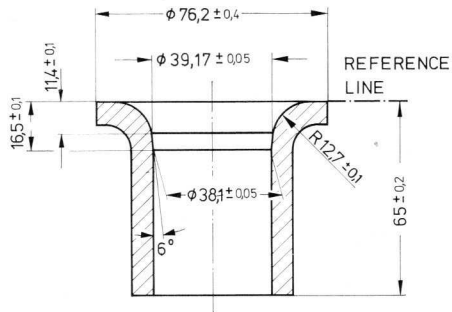

for picture tube
AW 17-69

Reference line gauge
deflection angle 110°
neck diameter 20 mm

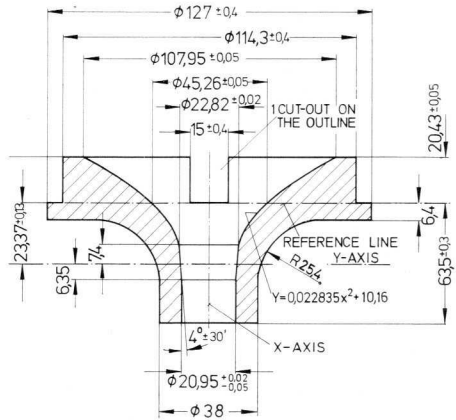

for picture tubes

A 31 - 120 W	A 31 - 121 W
A 31 - 250 W	A 31 - 251 W
A 44 - 280 W	A 44 - 281 W
A 37 - 110 W	

Black and White Picture Tubes

A 31-19 W

A 31 - 191 W

31 cm rectangular picture tube with 90° deflection angle, electrostatic focusing, aluminumized screen and tension band including tube mount for battery-operated television sets

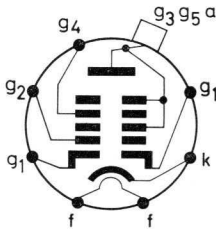

1. Generalities

Electron Gun	Tetrode with Einzel-Lens	
Heating Time ⁽¹⁶⁾	5s (approx.) A 31-191 W	
Bulb	All-Glass Type	
Base	Special Miniature (7 Pins)	
Focusing Method	Electrostatic	
Deflection Method	Magnetic	
Deflection Angles	Diagonal	90°
	Horizontal	80°
	Vertical	63°
Neck Diameter	20 mm	
Face	Shape	Spherical
	Material	Filter-Glass (Light Transmission 53% approx.)
Screen	Phosphor P 4 Aluminumized	
Fluorescence Colour	White	
Colour Temperature	12 000 °K (approx.)	
Minimum Useful Dimensions	257 x 195 mm Diagonal 295 mm	
Overall Length	268 ± 9,6 mm	
Weight	3 kg (approx.)	

2. Typical Operating Conditions ⁽¹⁾

U_f ⁽¹⁴⁾	11 V	
I_f	approx. 74 mA	
U_{g3g5a} ⁽⁷⁾	13	13 kV
U_{g2}	200 ... 350	⁽¹⁵⁾ 250 V
U_{g4} ⁽³⁾	0 ... 350	0 ... 350 V
U_k cutoff ⁽⁴⁾	45 32 ... 58 V	

3. Maximum Ratings

U_{g3g5a} max ^{(5) (7)}	14 kV
U_{g3g5a} min ^{(6) (7)}	10 kV
U_{g4} max	450 V
$(-U_{g4})$ max	100 V
I_{g4} max	25 μ A
U_{g2} max	450 V
U_{g2} min	180 V
U_k max	100 V
U_k p max	350 V
U_k min	0 V
$(-U_k)$ p max	2 V
$R_{k/g1}$ max	1,5 M Ω
$Z_{k/g1}$ (50 Hz) max	0,5 M Ω
$U_{\pm f/k}$ max ⁽⁹⁾	110 V
$U_{\pm f/k}$ p max	130 V
$R_{f/k}$ max ⁽¹¹⁾	1,0 M Ω
$Z_{f/k}$ max ⁽¹²⁾	0,1 M Ω

4. Capacitances

C_{g1}	approx.	6 pF
C_k	approx.	5 pF
$C_{g3g5a/m}$	approx.	700 pF
$C_{g3g5a/m'}$	approx.	125 pF

Implosion protection by steel reinforcement. Admitted by Association of German Electrical Engineers, VDE.

Black and White Picture Tubes

A 31-19 W
A 31-191 W

Dimensional Drawings in mm

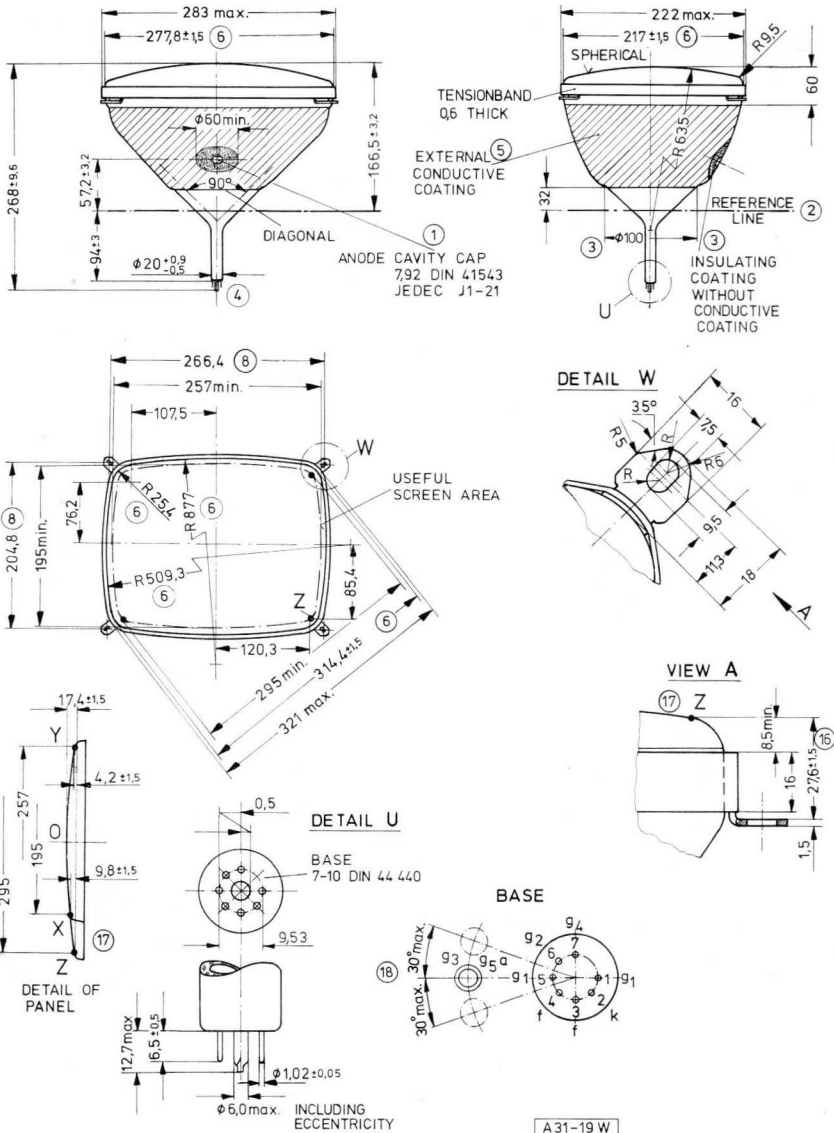

O Notes see pages 8 and 9

Reference line gauge see page 11

Black and White Picture Tubes

A 31-120 W

A 31-121 W

31 cm rectangular picture tube with 110° deflection angle, electrostatic focusing, aluminized screen and steel reinforcement including tube mount

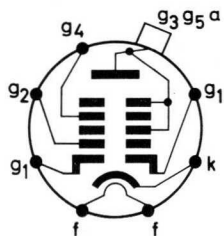

1. Generalities

Electron Gun	Tetrode with Einzel-Lens	
Heating Time ⑯	5s (approx.)	A 31-121 W
Bulb	All-Glass Type	
Base	Special Miniature (7 Pins)	
Focusing Method	Electrostatic	
Deflection Method	Magnetic	
Deflection Angles	Diagonal	110°
	Horizontal	99°
	Vertical	82°
Neck Diameter	20 mm	
Face	Shape	Spherical
	Material	Filter-Glass (Light Transmission 52% approx.)
Screen	Phosphor P 4 Aluminized	
Fluorescence Colour	White	
Colour Temperature	12 000 °K (approx.)	
Minimum Useful Dimensions	257 x 195 mm Diagonal 295 mm	
Overall Length	233 mm max.	
Weight	2,7 kg (approx.)	

2. Typical Operating Conditions ①

U_f ⑭	11 V	
I_f	approx. 74 mA	
U_{g3g5a} ⑦	13	13 kV
U_{g2}	200 ... 350 ⑮	250 V
U_{g4} ③	0 ... 350	0 ... 350 V
U_k cutoff ④	45	32 ... 58 V

3. Maximum Ratings

U_{g3g5a} max ⑤ ⑦	14 kV
U_{g3g5a} min ⑥ ⑦	10 kV
U_{g4} max	450 V
$(-U_{g4})$ max	50 V
U_{g2} max	350 V
U_{g2} min	200 V
U_k max	100 V
U_k min	0 V
U_k p max ⑧	350 V
$R_{k/g1}$ max	1,5 MΩ
$Z_{k/g1}$ max	0,5 MΩ
$U_{\pm f/k}$ max ⑨	110 V
$U_{\pm f/k}$ p max	130 V
$R_{f/k}$ max ⑪	1,0 MΩ
$Z_{f/k}$ max ⑫	0,1 MΩ

4. Ratings for Circuit Design

I_{g2}	\leq	\pm 5 μ A
I_{g4}	\leq	\pm 25 μ A
$R_{m/m'}$	\leq	2 MΩ

5. Capacitances

C_{g1}	approx.	6 pF
C_k	approx.	5 pF
$C_{g3g5a/m}$ max	850 pF	
$C_{g3g5a/m}$ min	550 pF	
$C_{g3g5a/m'}$ max	200 pF	

Implosion protection by steel reinforcement. Admitted by Association of German Electrical Engineers, VDE.

Black and White Picture Tubes

A 31—250 W

A 31—251 W

31 cm rectangular picture tube with 110° deflection angle, electrostatic focusing, aluminized screen and steel reinforcement including tube mount

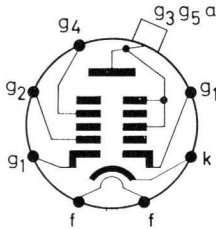

1. Generalities

Electron Gun	Tetrode with Einzel-Lens
Heating Time ⁽¹⁶⁾	5s (approx.) A 31—251 W
Bulb	All-Glass Type
Base	Special Miniature (7 Pins)
Focusing Method	Electrostatic
Deflection Method	Magnetic
Deflection Angles	Diagonal 110° Horizontal 99° Vertical 82°
Neck Diameter	20 mm
Face	Shape Spherical Material Filter-Glass (Light Transmission 52% approx.)
Screen	Phosphor P 4 Aluminized
Fluorescence Colour	White
Colour Temperature	12 000 °K (approx.)
Minimum Useful Dimensions	257 x 195 mm Diagonal 295 mm
Overall Length	229 mm max.
Weight	2,7 kg (approx.)

2. Typical Operating Conditions ⁽¹⁾

U_f ⁽¹⁴⁾	11 V	
I_f	approx. 74 mA	
U_{g3g5a} ⁽⁷⁾	13	13 kV
U_{g2}	200 ... 350 ⁽¹⁵⁾	250 V
U_{g4} ⁽³⁾	0 ... 350	0 ... 350 V
U_k cutoff ⁽⁴⁾	45	32 ... 58 V

3. Maximum Ratings

U_{g3g5a} max ^{(5) (7)}	14 kV
U_{g3g5a} min ^{(6) (7)}	10 kV
U_{g4} max	450 V
$(-U_{g4})$ max	50 V
U_{g2} max	350 V
U_{g2} min	200 V
U_k max	100 V
U_k min	0 V
$U_{k p}$ max ⁽⁸⁾	350 V
$R_{k/g1}$ max	1,5 MΩ
$Z_{k/g1}$ max	0,5 MΩ
$U_{\pm f/k}$ max ⁽⁹⁾	110 V
$U_{\pm f/k p}$ max	130 V
$R_{f/k}$ max ⁽¹¹⁾	1,0 MΩ
$Z_{f/k}$ max ⁽¹²⁾	0,1 MΩ

4. Ratings for Circuit Design

I_{g2}	$\leq \pm 5 \mu A$
I_{g4}	$\leq \pm 25 \mu A$
$R_{m/m'}$	$\geq 2 M\Omega$

5. Capacitances

C_{g1}	approx. 6 pF
C_k	approx. 5 pF
$C_{g3g5a/m}$ max	850 pF
$C_{g3g5a/m}$ min	550 pF
$C_{g3g5a/m'}$ max	200 pF

Implosion protection by steel reinforcement.
Admitted by Association of German Electrical Engineers, VDE.

Black and White Picture Tubes

A 31-250 W

A 31-251 W

Dimensional Drawings in mm

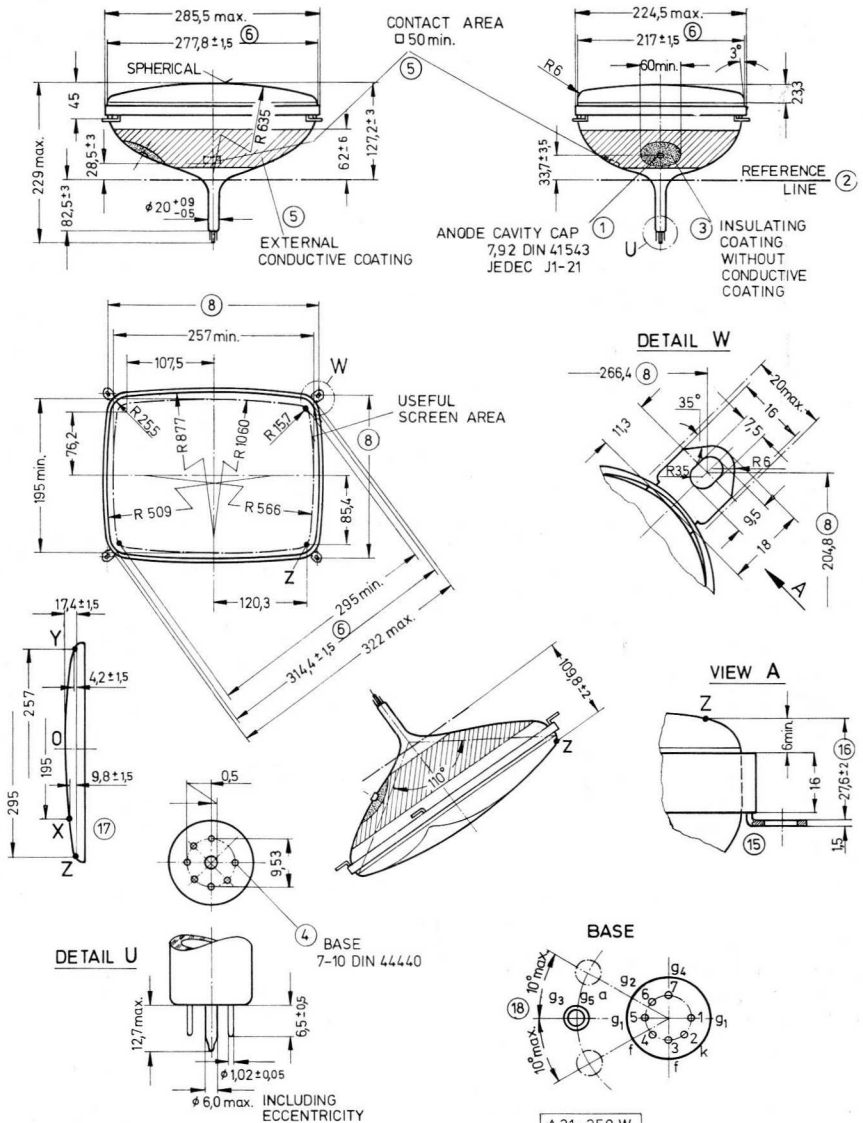

Black and White Picture Tubes

A 37-110 W

37 cm rectangular picture tube with 110° deflection angle, electrostatic focusing, aluminized screen and steel reinforcement including tube mount

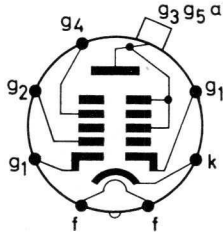

1. Generalities

Electron Gun	Tetrode with Einzel-Lens	
Bulb	All-glass Type	
Base	Spezial Miniature (7 pins)	
Focusing Method	Electrostatic	
Deflection Method	Magnetic	
Deflection Angles	Diagonal	110°
	Horizontal	99°
	Vertical	82°
Neck Diameter	20 mm	
Face	Shape	Spherical
	Material	Filter-Glass (Light Transmission 52% approx.)
Screen	Phosphor P 4 Aluminized	
Fluorescence Colour	White	
Colour Temperature	12 000 °K (approx.)	
Minimum Useful Dimensions	216 x 288 mm	
Overall Length	Diagonal 339 mm	
Weight	251 mm (max.)	
	3,2 kg (approx.)	

Implosion protection by steel reinforcement
Admitted by Association of German Electrical Engineers, VDE.

2. Typical Operating Conditions ①

U_f ⑭	11 V
I_f	approx. 74 mA
U_{g3g5a}	kV
U_{g2}	V
U_{g4} ③	0 ... 350 0 ... 350 V
$U_{k \text{ cutoff}}$ ④	45 32 ... 58 V

3. Maximum Ratings

$U_{g3g5a \text{ max}}$ ⑤ ⑦	14 kV
$U_{g3g5a \text{ min}}$ ⑥ ⑦	10 kV
$U_{g4 \text{ max}}$	450 V
$(-U_{g4}) \text{ max}$	50 V
$U_{g2 \text{ max}}$	350 V
$U_{g2 \text{ min}}$	200 V
$U_k \text{ max}$	100 V
$U_k \text{ min}$	0 V
$U_{k \text{ p max}}$ ⑧	350 V
$R_{k/g1 \text{ max}}$	1,5 MΩ
$Z_{k/g1 \text{ max}}$	0,5 MΩ
$U^{\pm} f/k \text{ max}$ ⑨	110 V
$U^{\pm} f/kp \text{ max}$	130 V
$R_{f/k \text{ max}}$ ⑩	1,0 MΩ
$Z_{f/k \text{ max}}$	0,1 MΩ

4. Ratings for Circuit Design

I_{g2}	$\leq \pm 5 \mu\text{A}$
I_{g4}	$\leq \pm 25 \mu\text{A}$
$R_{m/m'}$	$\geq 2 \text{ M}\Omega$

5. Capacitances

C_{g1}	approx.	6 pF
C_k	approx.	5 pF
$C_{g3g5a/m \text{ max}}$		850 pF
$C_{g3g5a/m \text{ min}}$		550 pF
$C_{g3g5a/m' \text{ max}}$		20 pF

Black and White Picture Tubes

A 44–13 W/3

A 44 – 13 W/3a

44 cm rectangular picture tube with 110° deflection angle, electrostatic focusing, aluminized screen and steel reinforcement including tube mount

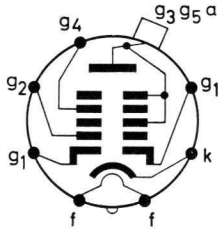

1. Generalities

Electron Gun	Tetrode with Einzel-Lens	
Bulb	All-Glass Type	
Base	German Standard DIN 44431 (Short Design)	
Focusing Method	Electrostatic	
Deflection Method	Magnetic	
Deflection Angles	Diagonal	110°
	Horizontal	99°
	Vertical	82°
Neck Diameter	28,6 mm	
Face	Shape	Spherical
	Material	Filter-Glass (Light Transmission 53% approx.)
Screen	Phosphor P 4 Aluminized	
Fluorescence Colour	White	
Colour Temperature	12 000 °K (approx.)	
Minimum Useful	346 x 270 mm	
Dimensions	Diagonal 413 mm	
Overall Length	293,2 ± 6,5 mm	
Weight	5,6 kg (approx.)	

Implosion protection by steel reinforcement.
Admitted by Association of German Electrical Engineers, VDE.

2. Typical Operating Conditions ①

U_f ②	6,3 V	
I_f	0,3 ± 6% A	
U_{g3g5a}	20 kV	
U_{g2}	400	500 V
U_{g4} ③	0 ... 400	0 ... 400 V
U_k cutoff ④	36 ... 66	45 ... 79 V

3. Maximum Ratings

U_{g3g5a} max ⑤	20 kV
U_{g3g5a} min ⑥	13 kV
R_{g3g5a} min	16 kΩ
U_{g4} max	1000 V
$(-U_{g4})$ max	500 V
R_{g4} min	470 Ω
U_{g2} max	550 V
U_{g2} min	350 V
R_{g2} min	470 Ω
U_k max	150 V
U_k min	0 V
$U_{k p}$ max ⑧	400 V
$(-U_k)_p$ max	2 V
$R_{k/g 1}$ max	1,5 MΩ
$Z_{k/g 1}$ max	0,5 MΩ
R_{g1} min	150 Ω
P_{lm} max	10 mW/cm ²
$U_{-f/k}$ max 1 ⑩ ⑨	410 V
$U_{-f/k}$ max 2 ⑩ ⑨	200 V
$U_{+f/k}$ max	135 V
$R_{f/k}$ max ⑪	1,0 MΩ
$Z_{f/k}$ max ⑫	0,1 MΩ

4. Ratings for Circuit Design

I_{g2}	≤ ± 5 μA
I_{g4}	≤ ± 25 μA
$R_{m/m'}$	≥ 2 MΩ

5. Capacitances

C_{g1}	approx.	6 pF
C_k	approx.	5 pF
$C_{g3g5a/m}$ max		1200 pF
$C_{g3g5a/m}$ min		800 pF
$C_{g3g5a/m'}$	approx.	300 pF

Black and White Picture Tubes

A 44-13 W/3

Dimensional Drawings in mm

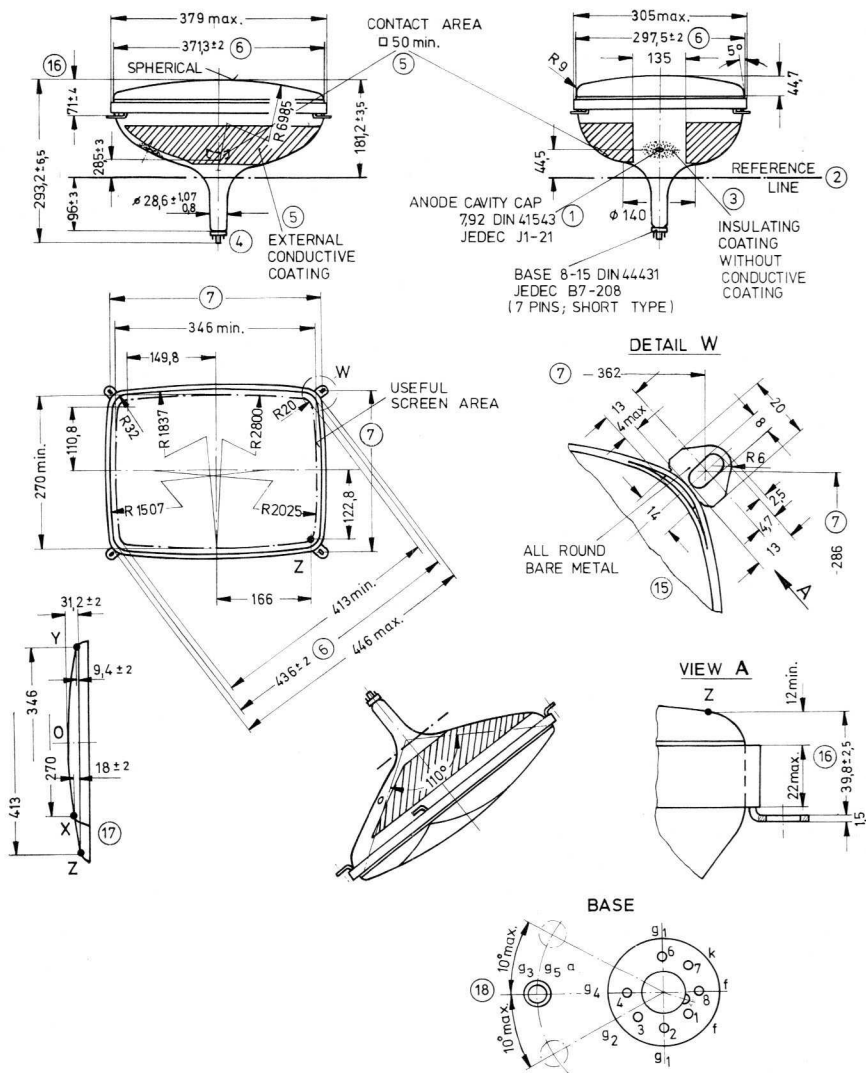

A 44-13W/3

O Notes see pages 8 and 9

Reference line gauge see page 11

Black and White Picture Tubes

Black and White Picture Tubes

A 44–280 W

A 44–281 W

44 cm rectangular picture tube with 110° deflection angle, electrostatic focusing, aluminized screen and steel reinforcement

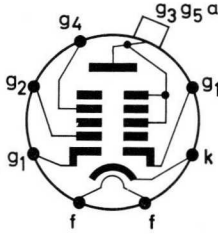

1. Generalities

Electron Gun	Tetrode with Einzel-Lens
Heating Time ⁽¹⁶⁾	5 s (approx.) A 44 – 281 W
Bulb	All-Glass Type
Base	Special Miniature (7 Pins)
Focusing Method	Electrostatic
Deflection Method	Magnetic
Deflection Angles	Diagonal 110° Horizontal 99° Vertical 82°
Neck Diameter	20 mm
Face Shape	Spherical
Material	Filter-Glass (Light Transmission 52 % approx.)
Screen	Phosphor P4 Aluminized
Fluorescence Colour	White
Colour Temperature	12 000 °K (approx.)
Minimum Useful Dimensions	346 x 270 mm Diagonal 413 mm
Overall Length	284 mm max.
Weight	5,6 kg (approx.)

Implosion protection by steel reinforcement.
Admitted by Association of
German Electrical Engineers, VDE.

2. Typical Operating Conditions ⁽¹⁾

U_f ⁽¹⁴⁾		11 V
I_f	approx.	74 mA
U_{g3g5a} ⁽⁷⁾	13	13 kV
U_{g2}	200 ... 350 ⁽¹⁵⁾	250 V
U_{g4} ⁽³⁾	0 ... 350	0 ... 350 V
U_k cutoff ⁽⁴⁾	45	32 ... 58 V

3. Maximum Ratings

U_{g3g5a} max ^{(5) (7)}	14 kV
U_{g3g5a} min ^{(6) (7)}	10 kV
U_{g4} max	450 V
$(-U_{g4})$ max	50 V
U_{g2} max	350 V
U_{g2} min	200 V
U_k max	100 V
U_k min	0 V
$U_{k p}$ max ⁽⁸⁾	350 V
$R_{k/g1}$ max	1,5 MΩ
$Z_{k/g1}$ max	0,5 MΩ
$U_{\pm f/k}$ max ⁽⁹⁾	110 V
$U_{\pm f/k p}$ max	130 V
$R_{f/k}$ max ⁽¹¹⁾	1 MΩ
$Z_{f/k}$ max ⁽¹²⁾	0,1 MΩ

4. Ratings for Circuit Design

I_{g2}	∇	\pm	5 μA
I_{g4}	∇	\pm	25 μA
$r_{m/m'}$	∇		2 MΩ

5. Capacitances

C_{g1}	approx.	6 pF
C_k	approx.	5 pF
$C_{g3g5a/m}$ max		1500 pF
$C_{g3g5a/m}$ min		1000 pF
$C_{g3g5a/m'}$ max		550 pF

Black and White Picture Tubes

A 44-280 W

A 44-281 W

Dimensional Drawings in mm

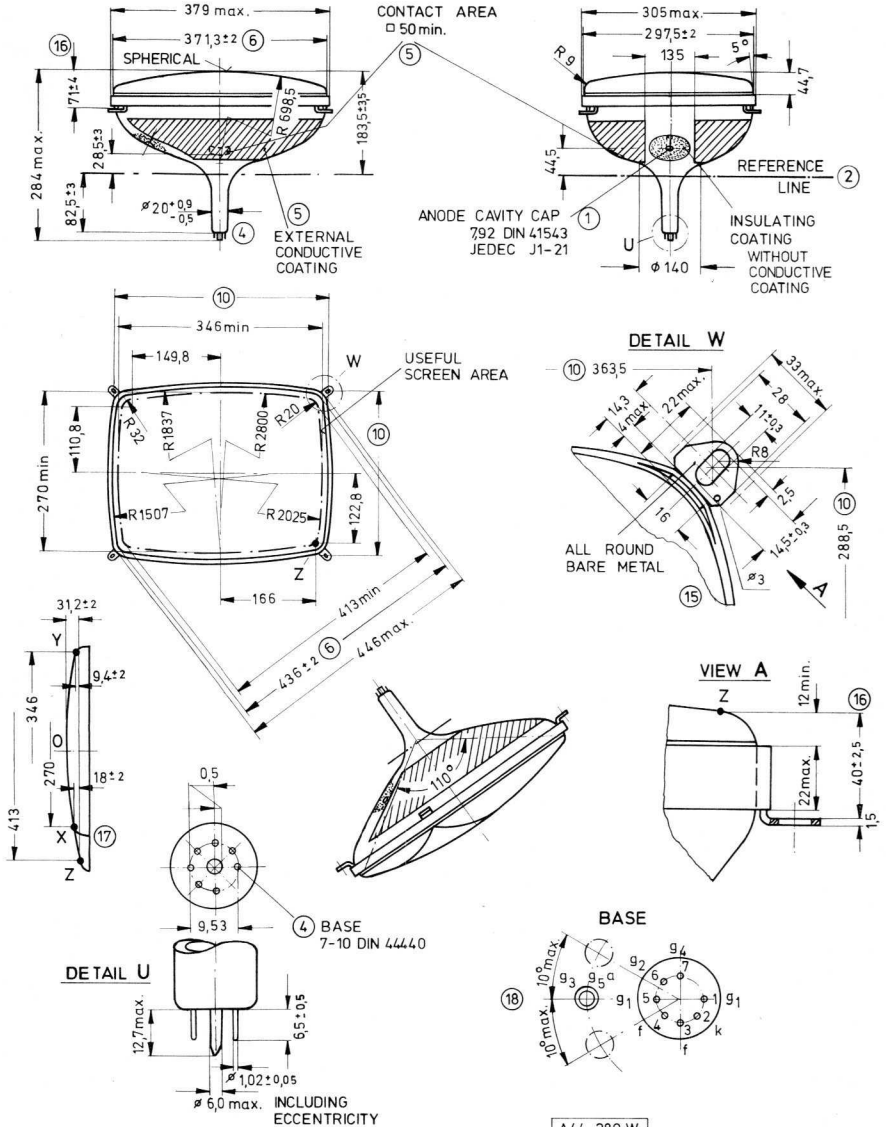

0 Notes see pages 8 and 9

Reference line gauge see page 10

Black and White Picture Tubes

A 51-10 W

51 cm rectangular picture tube with 110° deflection angle, electrostatic focusing, aluminized screen and steel reinforcement including tube mount

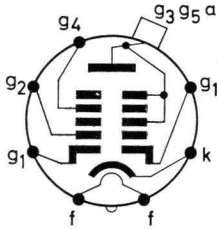

1. Generalities

Electron Gun	Tetrode with Einzel-Lens
Bulb	All-Glass Type
Base	German Standard DIN 44431 (Short Design)
Focusing Method	Electrostatic
Deflection Method	Magnetic
Deflection Angles	Diagonal 110° Horizontal 99° Vertical 82°
Neck Diameter	28,6 mm
Face	Shape Spherical Material Filter-Glass
Screen	(Light Transmission 49 % approx.) Phosphor P 4 Alu- minized
Fluorescence Colour	White
Colour Temperature	12 000 °K (approx.)
Minimum Useful	394 x 308 mm
Dimensions	Diagonal 473 mm
Overall Length	321,5 ± 6,5 mm
Weight	10 kg (approx.)

2. Typical Operating Conditions

U_f ②	6,3 V	
I_f	0,3 ± 6% A	
U_{g3g5a}	20 kV	
U_{g2}	400	500 V
U_{g4} ③	0 ... 400	0 ... 400 V
$(-U_{g1})$ cutoff ④	40 ... 77	50 ... 93 V
U_k cutoff ④	36 ... 66	45 ... 79 V

3. Maximum Ratings

U_{g3g5a} max ⑤	20 kV
U_{g3g5a} min ⑥	13 kV
R_{g3g5a} min	16 kΩ
U_{g4} max	1000 V
$(-U_{g4})$ max ⑬	500 V
I_{g4} max	25 μA
R_{g4} min	470 Ω
U_{g2} max	550 V
U_{g2} min	350 V
R_{g2} min	470 Ω
U_{g1} max	0 V
$(-U_{g1})$ max	150 V
$U_{g1 p}$ max	2 V
$(-U_{g1}) p$ max	400 V
R_{g1} max	1,5 MΩ
Z_{g1} max	0,5 MΩ
R_{g1} min	150 Ω
P_{Im} max	10 mW/cm ²
$U_{-f/k}$ max 1 ⑩ ⑨	410 V
$U_{-f/k}$ max 2 ⑩ ⑨	250 V
$U_{-f/k p}$ max	300 V
$U_{+f/k}$ max	135 V
$R_{f/k}$ max ⑪	1,0 MΩ
$Z_{f/k}$ max ⑫	0,1 MΩ

4. Capacitances

C_{g1}	approx.	6 pF
C_k	approx.	5 pF
$C_{g3g5a/m}$ min		1400 pF
$C_{g3g5a/m}$ max		2100 pF
$C_{g3g5a/m}'$	approx.	390 pF

Implosion protection by steel reinforcement. Admitted by Association of German Electrical Engineers, VDE.

Black and White Picture Tubes

A 51-10 W

Dimensional Drawings in mm

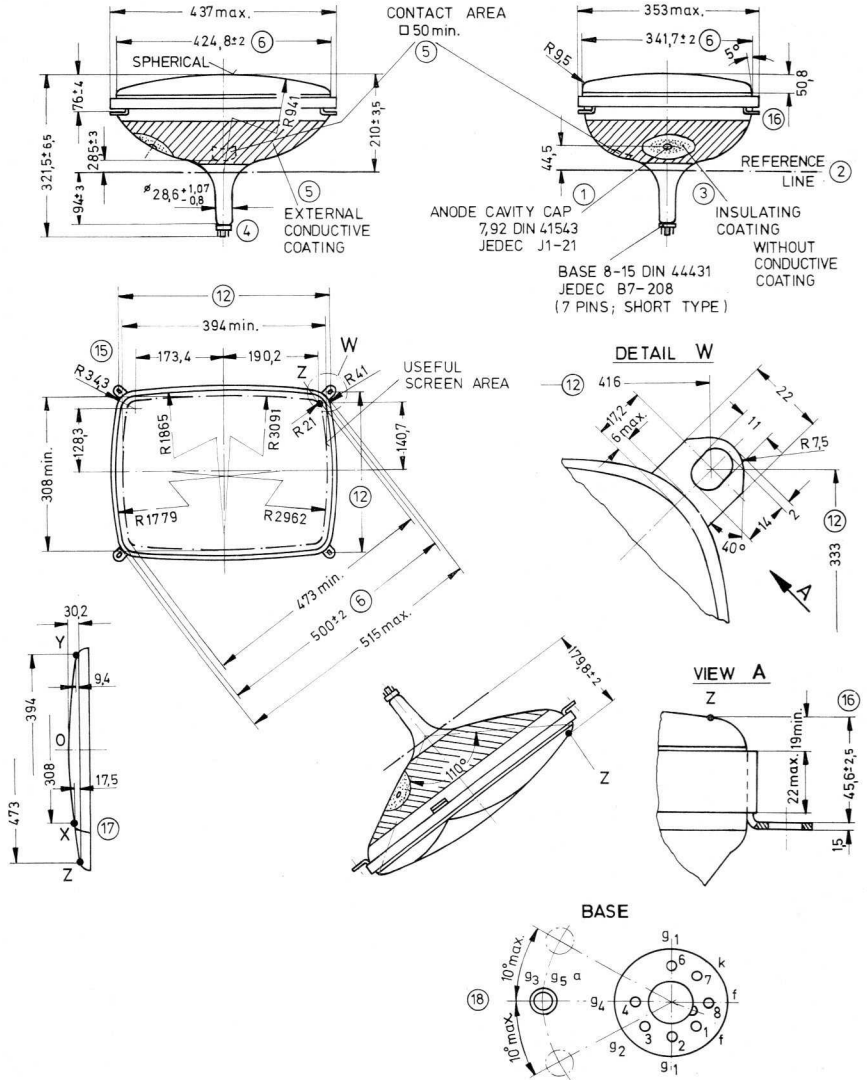

A 51-10 W

O Notes see pages 8 and 9

Reference line gauge see page 11

Black and White Picture Tubes

A 61-120 W/2

61 cm rectangular picture tube with 110° deflection angle, electrostatic focusing, aluminized screen and steel reinforcement including tube mount

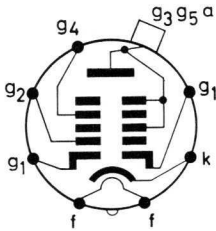

1. Generalities

Electron Gun	Tetrode with Einzel-Lens
Bulb	All-Glass Type
Base	German Standard DIN 44431 (Short Design)
Focusing Method	Electrostatic
Deflection Method	Magnetic
Deflection Angles	Diagonal 110° Horizontal 99° Vertical 82°
Neck Diameter	28,6 mm
Face	Shape Spherical Material Filter-Glass
Screen	Phosphor P 4 Aluminized
Fluorescence Colour	White
Colour Temperature	12 000 °K (approx.)
Minimum Useful Dimensions	481 x 375 mm Diagonal 577,5 mm
Overall Length	362 ± 8 mm
Weight	13 kg (approx.)

Implosion protection by steel reinforcement. Admitted by Association of German Electrical Engineers, VDE.

2. Typical Operating Conditions

U_f ②	6,3 V
I_f	0,3 ± 6% A
U_{g3g5a}	20 kV
U_{g2}	400 500 V
U_{g4} ③	0 ... 400 0 ... 400 V
$(-U_{g1})$ cutoff ④	40 ... 77 50 ... 93 V
U_k cutoff ④	36 ... 66 45 ... 79 V

3. Maximum Ratings

U_{g3g5a} max ⑤	20 kV
U_{g3g5a} min ⑥	13 kV
R_{g3g5a} min	16 kΩ
U_{g4} max	1000 V
U_{g4} p max ⑧	2500 V
$(-U_{g4})$ max	500 V
R_{g4} min	470 Ω
U_{g2} max	550 V
U_{g2} min	350 V
R_{g2} min	470 Ω
U_{g1} max	0 V
U_{g1} p max	2 V
$(-U_{g1})$ max	150 V
$(-U_{g1})$ p max ⑧	400 V
R_{g1} max	1,5 MΩ
Z_{g1} max	0,5 MΩ
R_{g1} min	150 Ω
P_{lm} max	10 mW/cm ²
$U_{-f/k}$ max 1 ⑩ ⑨	410 V
$U_{-f/k}$ max 2 ⑩ ⑨	250 V
$U_{-f/k}$ p max	300 V
$U_{+f/k}$ max	135 V
$U_{+f/k}$ p max	180 V
$R_{f/k}$ max ⑪	1,0 MΩ
$Z_{f/k}$ max ⑫	0,1 MΩ

4. Ratings for Circuit Design

I_{g2}	≤ ± 5 μA
I_{g4}	≤ ± 25 μA
$R_{m/m'}$	≥ 2 MΩ

5. Capacitances

C_{g1}	approx.	6 pF
C_k	approx.	5 pF
$C_{g3g5a/m}$ max		2600 pF
$C_{g3g5a/m}$ min		1700 pF
$C_{g3g5a/m'}$ max		580 pF
$C_{g3g5a/m'}$ min		380 pF

Black and White Picture Tubes

A 61-120 W/2

Dimensional Drawings in mm

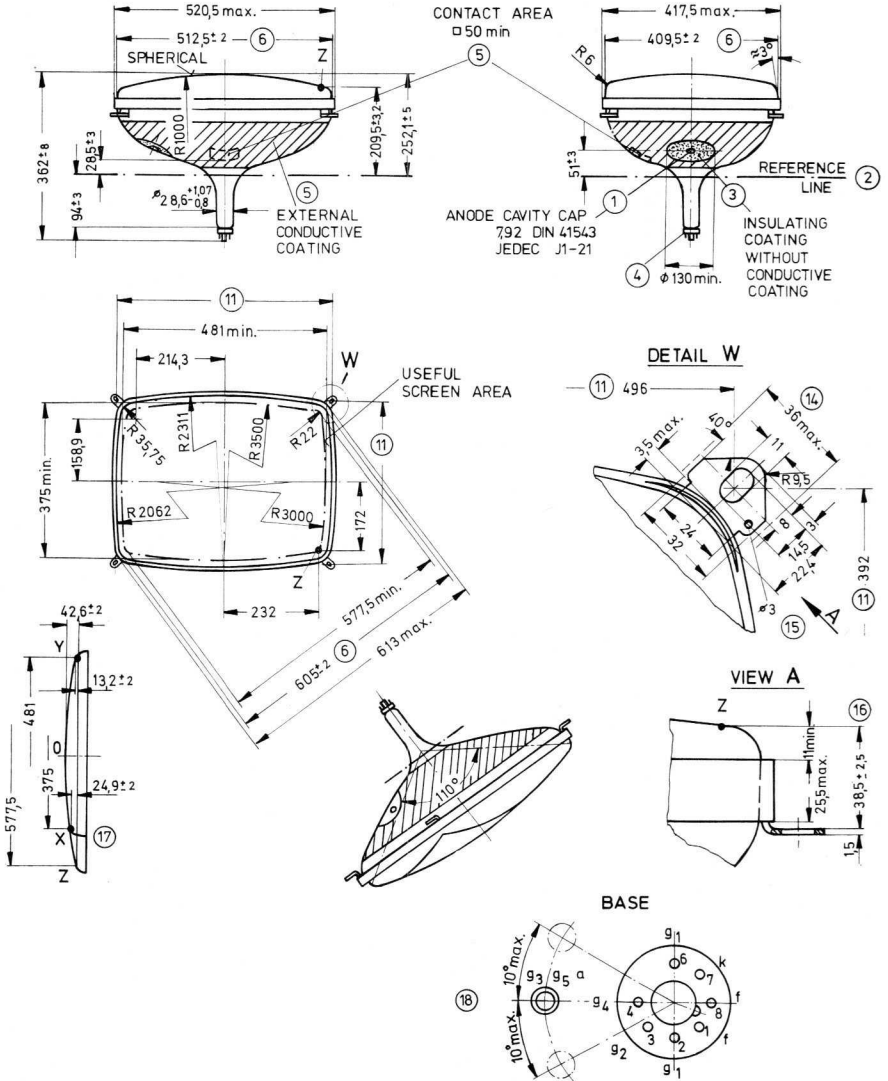

A61-120 W/2

O Notes see pages 8 and 9

Reference line gauge see page 11

Black and White Picture Tubes

AW 17-69 and A 17-69 . .

For Replacement

17 cm rectangular picture tube, aluminized screen, for industrial television

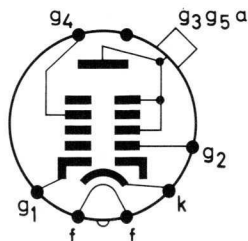

Electron Gun	Tetrode with Einzel-Lens
Bulb	All-Glass Type
Base	Duodecal DIN 41536 with 7 Pins
Focusing Method	Electrostatic
Deflection Method	Magnetic
Deflection Angles	Diagonal 70° Horizontal 60° Vertical 50°
Neck Diameter	36,5 mm
Face Shape	Flat
Material	Clear Glass
Screen	Phosphor P4 Aluminized
Minimum Useful Dimensions	96 x 126 mm Diagonal 155 mm
Overall Length	256 ± 10 mm
Weight	0,7 kg (approx.)

1. Generalities

Type	Fluorescence Colour	Persistence
AW 17-69	Whitish	Medium
A 17-69 BE	Blue	Medium Short
A 17-69 GJ	Yellowish-Green	Medium
A 17-69 GM	Purplish-Blue	Long
A 17-69 LF	Orange	Long

2. Typical Operating Conditions

U_f ②	6,3 V
I_f	$0,3 \pm 6\%$ A
U_{g3g5a}	14 kV
U_{g2}	300 400 V
U_{g4} ③	0 ... 400 0 ... 400 V
$(-U_{g1})$ cutoff ④	35 ... 75 48 ... 102 V

3. Maximum Ratings

U_{g3g5a} max ⑤	16 kV
U_{g3g5a} min ⑥	12 kV
U_{g4} max	460 V
U_{g2} max	460 V
U_{g2} min	200 V
U_{g1} max	0 V
$(-U_{g1})$ max	150 V
U_{g1} p max	2 V
$(-U_{g1})$ p max ⑧	400 V
P_{lm} max	10 mW/cm ²
R_{g1} max	1,0 MΩ
Z_{g1} max	0,5 MΩ

$R_{f/k}$ max ⑪	1,0 MΩ
$Z_{f/k}$ max ⑫	0,1 MΩ
$U_{-f/k}$ max 1 ⑨ ⑩	410 V
$U_{-f/k}$ max 2 ⑨ ⑩	250 V
$U_{-f/k}$ p max	300 V
$U_{+f/k}$ max	135 V
$U_{+f/k}$ p max	180 V
R_{g1} min	150 Ω
R_{g2} min	470 Ω
R_{g4} min	470 Ω
R_{g3g5a} min	16 kΩ

4. Ratings for Circuit Design

I_{g2}	$\leq \pm 5 \mu A$
I_{g4}	$\leq \pm 25 \mu A$

5. Capacitances

c_{g1}	approx. 7 pF
c_k	approx. 5 pF
$C_{g3g5a/m}$ min	400 pF
$C_{g3g5a/m}$ max	800 pF

Black and White Picture Tubes

AW 17-69 and A 17-69 . .

For Replacement

Dimensional Drawings in mm

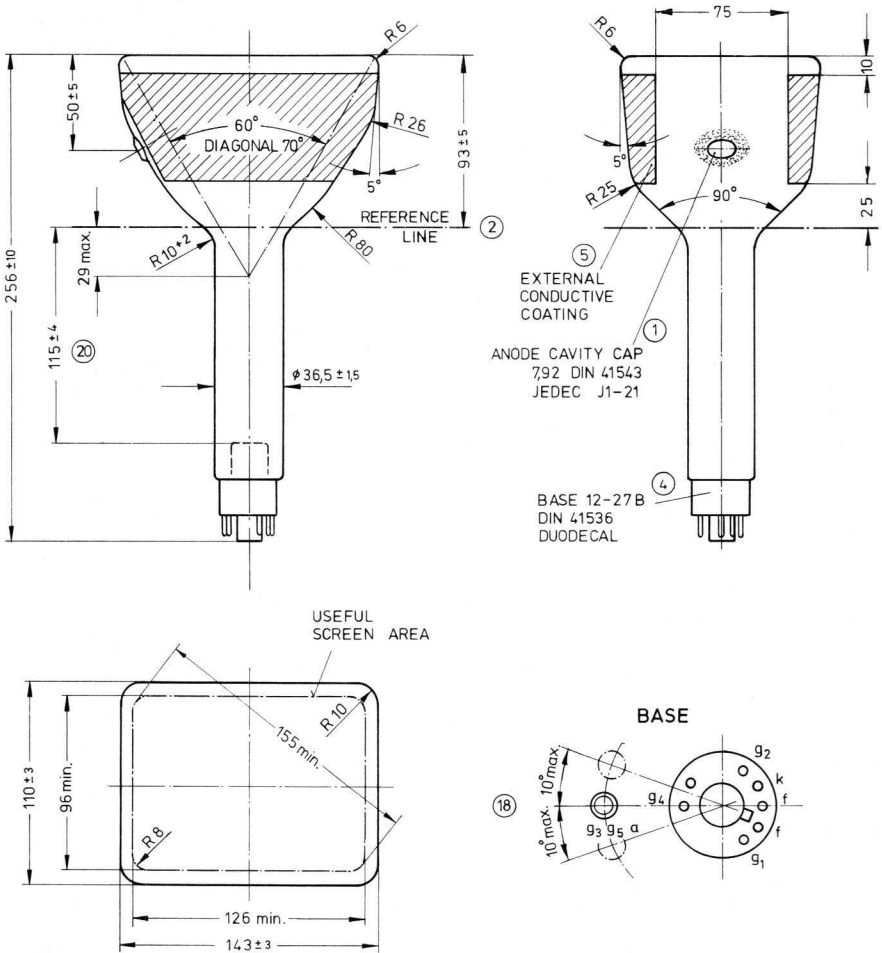

AW 17-69

O Notes see pages 8 and 9

Reference line gauge see page 10

Black and White Picture Tubes

M 17-18 W

For Replacement

17 cm rectangular monitor tube with 70° deflection angle, electrostatic focusing, and aluminized screen

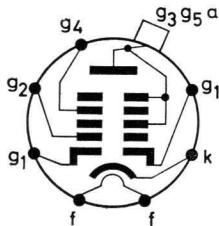

1. Generalities

Type	Fluorescence Colour	Persistence
M 17 - 18 W	Whitish	Medium
M 17 - 18 BE	Blue	Medium Short
M 17 - 18 GJ	Yellowish-Green	Medium
M 17 - 18 GM	Purplish-Blue	Long
M 17 - 18 LF	Orange	Long

2. Typical Operating Conditions ①

U_f ⑭	11 V
I_f	approx. 74 mA
U_{g3g5a}	11 kV
U_{g2}	200-350 ⑮ 250 V
U_{g4} ③	-100 ... + 300 -100 ... + 300 V
$U_{k \text{ cutoff}}$ ④	45 32 ... 58 V

3. Maximum Ratings

$U_{g3g5a \text{ max}}$ ⑤	12 kV
$U_{g3g5a \text{ min}}$ ⑥	7,5 kV
$U_{g4 \text{ max}}$	450 V
$(-U_{g4})_{\text{max}}$	100 V
$U_{g2 \text{ max}}$	450 V
$U_{g2 \text{ min}}$	180 V
$U_{k \text{ max}}$	100 V
$U_{k \text{ min}}$	0 V
$U_{k \text{ p max}}$ ⑧	350 V

Electron Gun	Tetrode with Einzel-Lens
Bulb	All-Glass Type
Base	Special Miniature (7 Pins)
Focusing Method	Electrostatic
Deflection Method	Magnetic
Deflection Angles (approx.)	Diagonal 70° Horizontal 60° Vertical 50°
Neck Diameter	20 mm
Face Shape	Flat
Material	Clear Glass
Screen	Phosphor P4 Aluminized
Minimum Useful Dimensions	95 x 125 mm Diagonal 155 mm
Overall Length	205 mm max.
Weight	0,7 kg (approx.)

$(-U_k)_p \text{ max}$	2 V
$R_{e1 \text{ max}}$	1,5 MΩ
$Z_{g1} (50 \text{ Hz})_{\text{max}}$	0,5 MΩ
$U_{\pm f/k \text{ max}}$ ⑨	110 V
$U_{\pm f/k \text{ p max}}$	130 V
$R_{f/k \text{ max}}$ ⑪	1 MΩ
$Z_{f/k} (50 \text{ Hz})_{\text{max}}$ ⑫	0,1 MΩ

4. Ratings for Circuit Design

I_{g2}	$\leq \pm 5 \mu\text{A}$
I_{g4}	$\leq \pm 25 \mu\text{A}$

5. Capacitances

C_{e1}	approx. 6 pF
C_k	approx. 3 pF
$C_{g3g5a/m}$	approx. 350 pF

Black and White Picture Tubes

M 17-18 W

For Replacement

Dimensional Drawings in mm

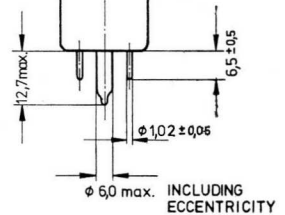
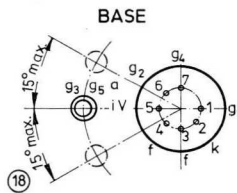
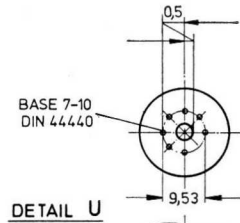
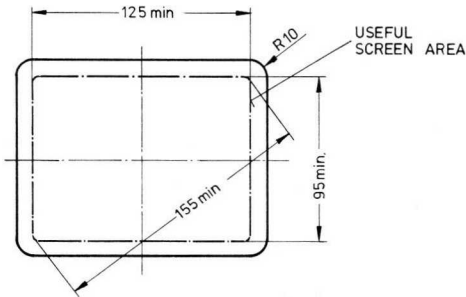
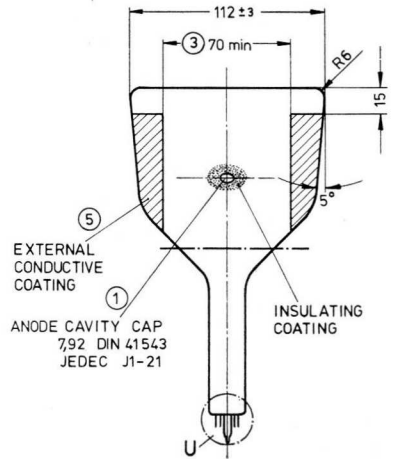
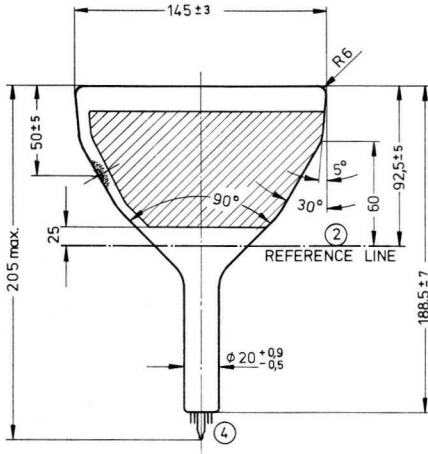

M17-18 W

O Notes see pages 8 and 9

Reference line gauge see page 11

Black and White Picture Tubes

A 28-13 W

For Replacement

28 cm rectangular picture tube with 90° deflection angle, electrostatic focusing, aluminized screen and tension band including tube mount for battery-operated television sets

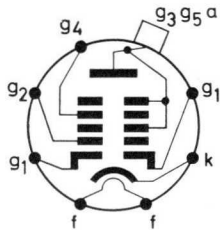

1. Generalities

Electron Gun	Tetrode with Einzel-Lens
Bulb	Al-Glass Type
Base	Special Miniature (7 Pins)
Focusing Method	Electrostatic
Deflection Method	Magnetic
Deflection Angles	Diagonal 90° Horizontal 80° Vertical 63°
Neck Diameter	20 mm
Face	Shape Spherical Material Filter-Glass (Light Transmission 57% (approx.))
Screen	Phosphor P4 Aluminized
Fluorescence Colour	White
Colour Temperature	12 000 °K (approx.)
Minimum Useful Dimensions	228 x 171 mm Diagonal 262,5 mm
Overall Length	245 ± 5 mm
Weight	2,0 kg (approx.)

Implosion protection by steel reinforcement. Admitted by Association of German Electrical Engineers, VDE.

2. Typical Operating Conditions ①

U_f ⑭	11 V
I_f	approx. 75 mA
U_{g3g5a} ⑦	13 kV
U_{g2}	200 ... 350 250 V
U_{g4} ③	0 ... 350 0 ... 350 V
$U_{k \text{ cutoff}}$ ④	45 32 ... 58 V

3. Maximum Ratings

$U_{g3g5a \text{ max}}$ ⑤ ⑦	14 kV
$U_{g3g5a \text{ min}}$ ⑥ ⑦	10 kV
$U_{g4 \text{ max}}$	450 V
$(-U_{g4})_{\text{max}}$	100 V
$I_{g4 \text{ max}}$	25 μ A
$U_{g2 \text{ max}}$	450 V
$U_{g2 \text{ min}}$	180 V
$U_k \text{ max}$	100 V
$U_k \text{ min}$	0 V
$U_{k \text{ p max}}$ ⑧	350 V
$R_{k/g1 \text{ max}}$	1,5 M Ω
$Z_{k/g1 \text{ max}}$	0,5 M Ω
$P_{\text{Im max}}$	10 mW/cm ²
$U_{\pm f/k \text{ max}}$ ⑨	110 V
$U_{\pm f/k \text{ p max}}$	130 V
$R_{f/k \text{ max}}$ ⑪	1,0 M Ω
$Z_{f/k \text{ max}}$ ⑫	0,1 M Ω

4. Capacitances

C_{g1}	approx. 6 pF
C_k	approx. 5 pF
$C_{g3g5a/m}$	approx. 700 pF
C_{g3g5a/m^2}	approx. 150 pF

Black and White Picture Tubes

A 28-13 W

For Replacement

Dimensional Drawings in mm

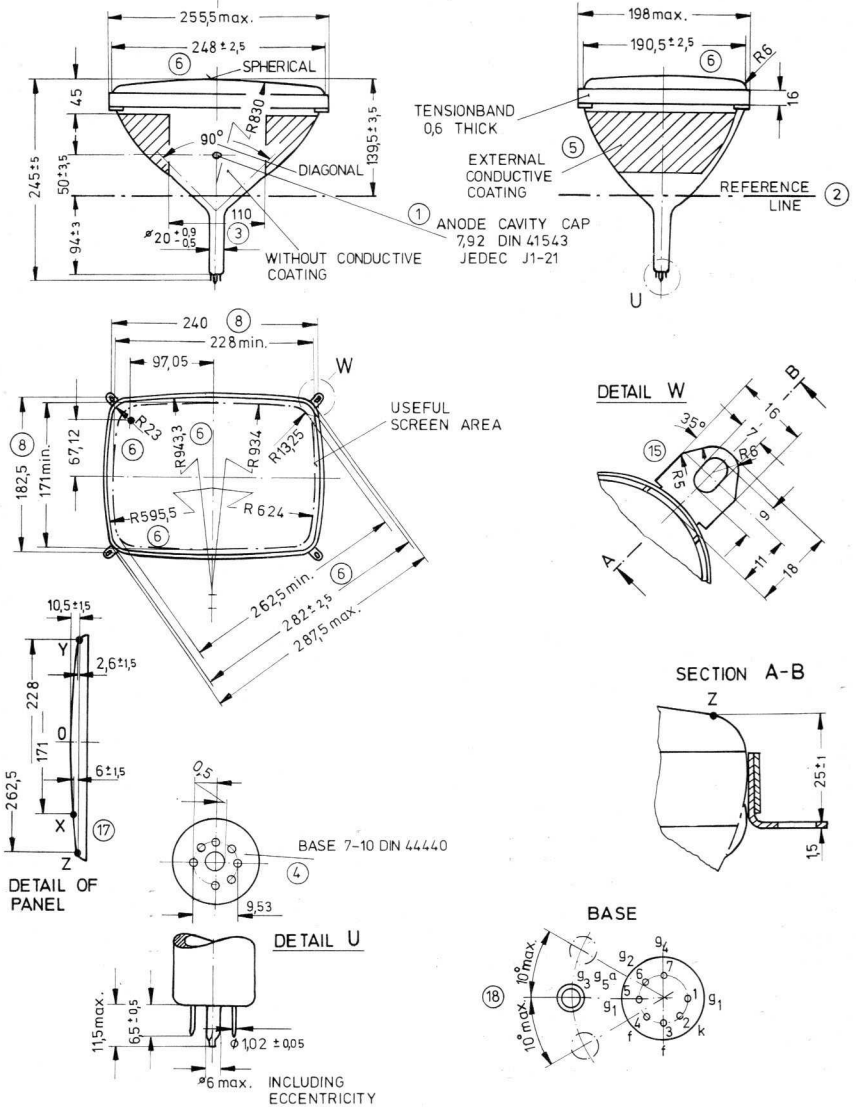

O Notes see pages 8 and 9

Reference line gauge see page 11

Black and White Picture Tubes

A 31-15 W

For Replacement

31 cm rectangular picture tube with 110° deflection angle, electrostatic focusing, aluminumized screen and tension band including tube mount

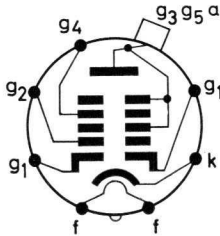

1. Generalities

Electron Gun	Tetrode with Einzel-Lens
Bulb	All-Glass Type
Base	German Standard DIN 44431 (Short Design)
Focusing Method	Electrostatic
Deflection Method	Magnetic
Deflection Angles	Diagonal 110° Horizontal 99° Vertical 80°
Neck Diameter	28,6 mm
Face	Shape Spherical Material Filter-Glass (Light Transmission 53 % approx.)
Screen	Phosphor P4 Aluminumized
Fluorescence Colour	White
Colour Temperature	12 000 °K (approx.)
Minimum Useful Dimensions	257 x 195 mm Diagonal 295 mm
Overall Length	237,6 ± 6,4 mm
Weight	2,7 kg (approx.)

Implosion protection by steel reinforcement.
Admitted by Association of German Electrical Engineers, VDE.

2. Typical Operating Conditions ①

U_f ②	6,3 V
I_f	0,3 ± 6% A
U_{g3g5a}	12 kV
U_{g2}	300 V
U_{g4} ③	0 ... 400 V
U_k cutoff ④	35 ... 69 V

3. Maximum Ratings

$U_{g3g5a \text{ max}}$ ⑤	18 kV
$U_{g3g5a \text{ min}}$ ⑥	12 kV
$R_{g3g5a \text{ min}}$	16 kΩ
$U_{g4 \text{ max}}$	1000 V
$(-U_{g4}) \text{ max}$	500 V
$I_{g4 \text{ max}}$	25 μA
$R_{g4 \text{ min}}$	470 Ω
$U_{g2 \text{ max}}$	550 V
$U_{g2 \text{ min}}$	200 V
$R_{g2 \text{ min}}$	470 Ω
$U_k \text{ max}$	150 V
$U_k \text{ p max}$	220 V
$U_k \text{ min}$	0 V
$(-U_k) \text{ p max}$	2 V
$R_{k/g1 \text{ max}}$	1,5 MΩ
$Z_{k/g1 \text{ max}}$	0,5 MΩ
$R_{g1 \text{ min}}$	150 Ω
$P_{\text{Im max}}$	10 mW/cm²
$U_{-f/k \text{ max 1}}$ ⑩ ⑨	410 V
$U_{-f/k \text{ max 2}}$ ⑩ ⑨	200 V
$U_{+f/k \text{ max}}$	135 V
$R_{f/k \text{ max}}$ ⑪	1,0 MΩ
$Z_{f/k \text{ max}}$ ⑫	0,1 MΩ

4. Capacitances

C_{g1}	approx.	6 pF
C_k	approx.	5 pF
$C_{g3g5a/m}$	approx.	650 pF
$C_{g3g5a/m' \text{ max}}$		200 pF

Black and White Picture Tubes

A 41-10 W

For Replacement

41 cm rectangular picture tube with 110° deflection angle, electrostatic focusing, aluminized screen and steel jacket including tube mount

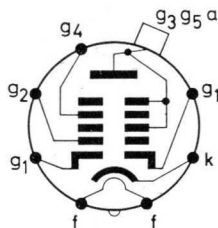

1. Generalities

Electron Gun	Tetrode with Einzel-Lens
Bulb	All-Glass Type
Base	German Standard DIN 44431 (Short Design)
Focusing Method	Electrostatic
Deflection Method	Magnetic
Deflection Angles	Diagonal 110° Horizontal 99° Vertical 82°
Neck Diameter	28,6 mm
Face	Shape Spherical Material Filter-Glass (Light Transmission 63 % approx.)
Screen	Phosphor P4 Alu- minized
Fluorescence Colour	White
Colour Temperature	12 000 °K (approx.)
Minimum Useful Dimensions	322 x 254 mm Diagonal 372 mm
Overall Length	273 ± 7 mm
Weight	4,2 kg (approx.)

Implosion protection by steel reinforcement.
Admitted by Association of German Elec-
trical Engineers, VDE.

2. Typical Operating Conditions

U_f ②	6,3 V
I_f	$0,3 \pm 6\%$ A
U_{g3g5a}	18 kV
U_{g2}	400 V
U_{g4} ③	0 ... 400 V
$(-U_{g1})$ cutoff ④	40 ... 77 V
U_k cutoff ④	30 ... 66 V

3. Maximum Ratings

U_{g3g5a} max ⑤	18 kV
U_{g3g5a} min ⑥	13 kV
U_{g4} max	1000 V
$(-U_{g4})$ max	500 V
I_{g4} max	25 μ A
U_{g2} max	550 V
U_{g2} min	200 V
U_{g1} max	0 V
U_{g1} p max	2 V
$(-U_{g1})$ max	150 V
R_{g1} max	1,5 M Ω
Z_{g1} max	0,5 M Ω
P_{lm} max	10 mW/cm ²
$U_{-f/k}$ max 1 ⑩ ⑨	410 V
$U_{-f/k}$ max 2 ⑩ ⑨	200 V
$U_{+f/k}$ max	135 V
$R_{f/k}$ max ⑪	1,0 M Ω
$Z_{f/k}$ max ⑫	0,1 M Ω

4. Capacitances

C_{g1}	approx.	6 pF
C_k	approx.	5 pF
$C_{g3g5a/m}$ max		1500 pF
$C_{g3g5a/m}$ min		800 pF

Black and White Picture Tubes

A 41-10 W

For Replacement

Dimensional Drawings in mm

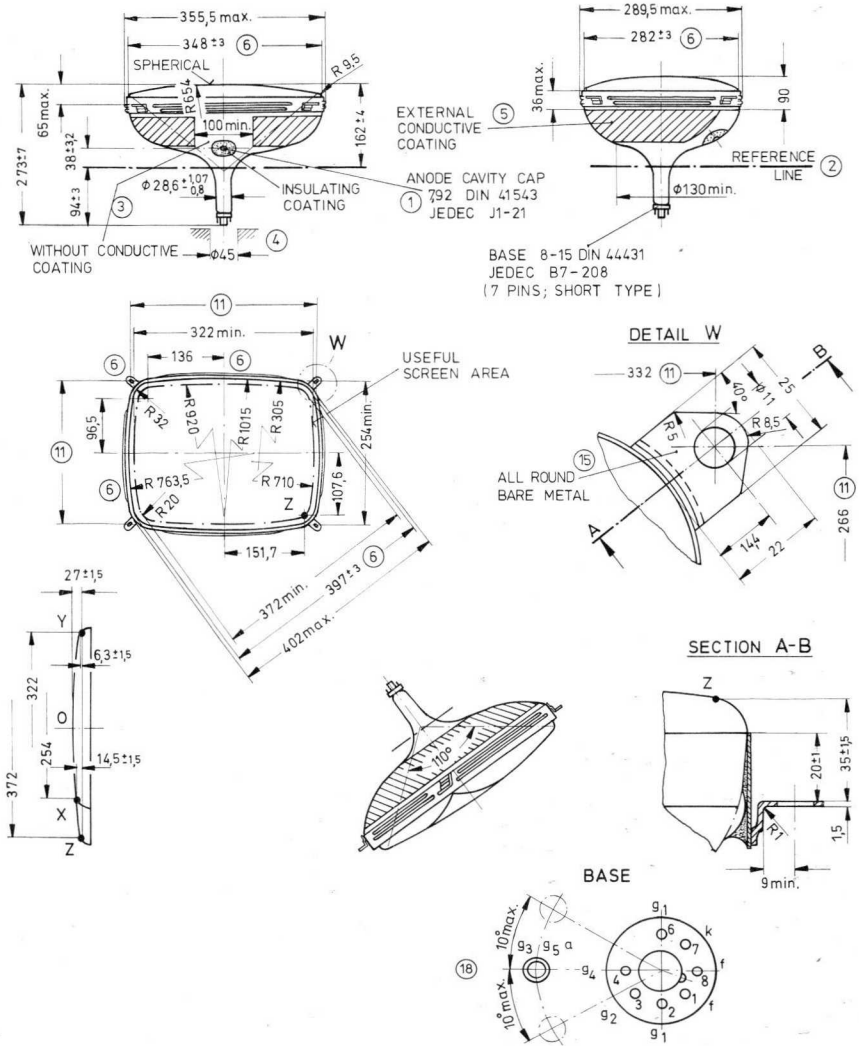

A41-10 W

O Notes see pages 8 and 9

Reference line gauge see page 11

Black and White Picture Tubes

A 47-27 W/2

For Replacement

47 cm rectangular picture tube with 110° deflection angle, electrostatic focusing, aluminumized screen and steel reinforcement including tube mount

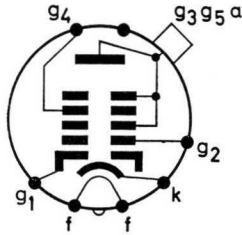

1. Generalities

Electron Gun	Tetrode with Einzel-Lens
Bulb	All-Glass Type
Base	German Standard DIN 44431 (Short Design)
Focusing Method	Electrostatic
Deflection Method	Magnetic
Deflection Angles	Diagonal 110° Horizontal 99° Vertical 82°
Neck Diameter	28,6 mm
Face	Shape Spherical Material Filter-Glass (Light Transmission 49 % approx.)
Screen	Phosphor P4 Aluminumized
Fluorescence Colour	White
Colour Temperature	12 000 °K (approx.)
Minimum Useful Dimensions	384 x 305 mm Diagonal 446 mm
Overall Length	302,5 ± 6,5 mm
Weight	8 kg (approx.)

Implosion protection by steel reinforcement. Admitted by Association of German Electrical Engineers, VDE.

2. Typical Operating Conditions

U_f ②	6,3 V
I_f	0,3 ± 6% A
U_{g3g5a}	20 kV
U_{g2}	400 500 V
U_{g4} ③	0 ... 400 0 ... 400 V
$(-U_{g1})$ cutoff ④	40 ... 77 50 ... 93 V
U_k cutoff ④	36 ... 66 45 ... 79 V

3. Maximum Ratings

U_{g3g5a} max ⑤	20 kV
U_{g3g5a} min ⑥	13 kV
R_{g3g5a} min	16 kΩ
U_{g4} max	1000 V
$U_{g4 p}$ max	2500 V
$(-U_{g4})$ max	500 V
R_{g4} min	470 Ω
U_{g2} max	550 V
U_{g2} min	350 V
R_{g2} min	470 Ω
U_{g1} max	0 V
$U_{g1 p}$ max	2 V
$(-U_{g1})$ max	150 V
$(-U_{g1}) p$ max ⑧	400 V
R_{g1} max	1,5 MΩ
Z_{g1} max	0,5 MΩ
R_{g1} min	150 Ω
P_{lm} max	10 mW/cm ²
$U_{-f/k}$ max 1 ⑩ ⑨	410 V
$U_{-f/k}$ max 2 ⑩ ⑨	200 V
$U_{-f/k p}$ max	300 V
$U_{+f/k}$ max	135 V
$U_{+f/k p}$ max	180 V
$R_{f/k}$ max ⑪	1,0 MΩ
$Z_{f/k}$ max ⑫	0,1 MΩ

4. Ratings for Circuit Design

I_{g2}	≤ ± 5 μA
I_{g4}	≤ ± 25 μA
$R_{m/m'}$	≥ 2 MΩ

5. Capacitances

C_{g1}	approx.	6 pF
C_k	approx.	5 pF
$C_{g3g5a/m}$ max		1500 pF
$C_{g3g5a/m}$ min		1000 pF
$C_{g3g5a/m'}$	approx.	350 pF

Black and White Picture Tubes

A 47-27 W/2

For Replacement

Dimensional Drawings in mm

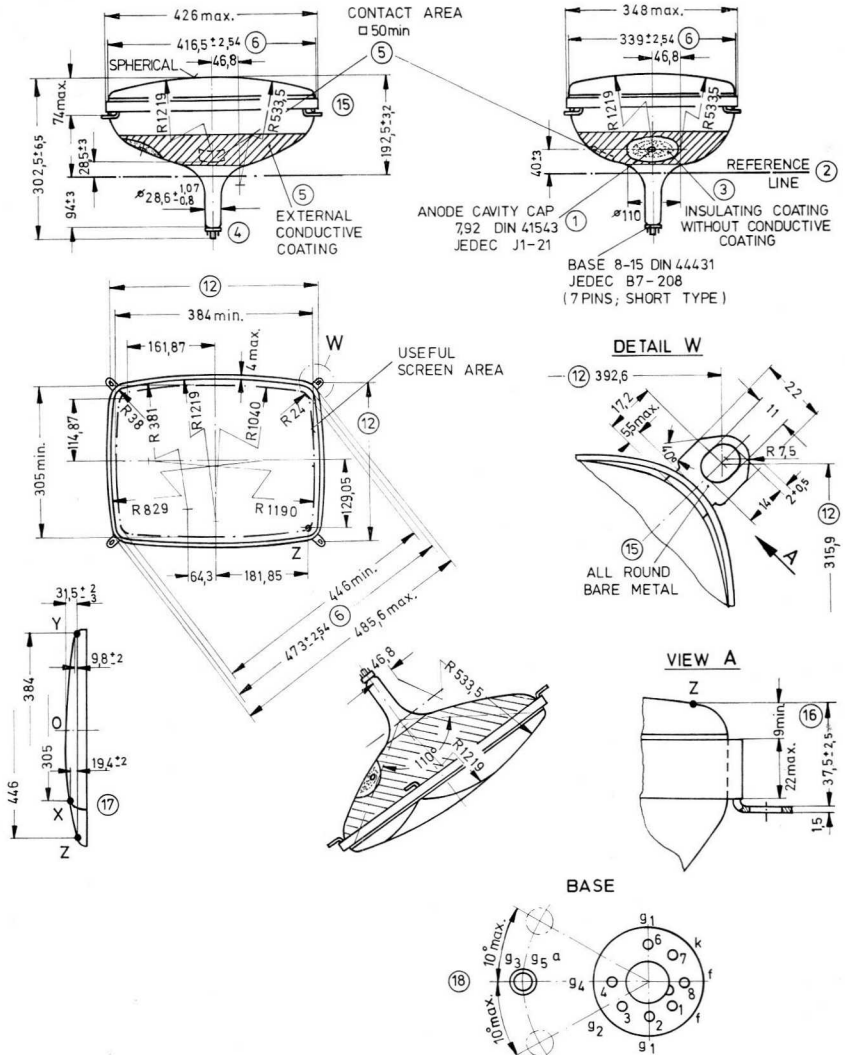

O Notes see pages 8 and 9

Reference line gauge see page 11

Black and White Picture Tubes

A 59—22 W

For Replacement

59 cm rectangular picture tube with 110° deflection angle, electrostatic focusing, aluminized screen and steel reinforcement including tube mount

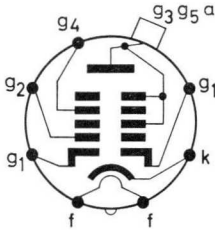

1. Generalities

Electron Gun	Tetrode with Einzel-Lens
Bulb	All-Glass Type
Base	German Standard DIN 44431 (Short Design)
Focusing Method	Electrostatic
Deflection Method	Magnetic
Deflection Angles	Diagonal 110° Horizontal 99° Vertical 82°
Neck Diameter	28,6 mm
Face	Shape Spherical Material Filter-glass
Screen	Phosphor P4 Aluminized
Fluorescence Colour	White
Colour Temperature	12 000 °K (approx.)
Minimum Useful Dimensions	489 x 385 mm Diagonal 566 mm
Overall Length	360 ± 8 mm
Weight	13 kg (approx.)

Implosion protection by steel reinforcement. Admitted by Association of German Electrical Engineers, VDE.

2. Typical Operating Conditions

U_f ②	6,3 V
I_f	0,3 ± 6% A
U_{g3g5a}	20 kV
U_{g2}	400 500 V
U_{g4} ③	0 ... 400 0 ... 400 V
$(-U_{g1})$ cutoff ④	40 ... 77 50 ... 93 V
U_k cutoff ④	36 ... 66 45 ... 79 V

3. Maximum Ratings

U_{g3g5a} max ⑤	20 kV
U_{g3g5a} min ⑥	13 kV
R_{g3g5a} min	16 kΩ
U_{g4} max	1000 V
$(-U_{g4})$ max	500 V
$U_{g4 p}$ max ⑧	2500 V
R_{g4} min	470 Ω
U_{g2} max	550 V
U_{g2} min	350 V
R_{g2} min	470 Ω
U_{g1} max	0 V
$U_{g1 p}$ max	2 V
$(-U_{g1})$ max	150 V
$(-U_{g1}) p$ max ⑧	400 V
R_{g1} max	1,5 MΩ
Z_{g1} max	0,5 MΩ
R_{g1} min	150 Ω
P_{lm} max	10 mW/cm ²
$U_{-f/k}$ max 1 ⑩ ⑨	410 V
$U_{-f/k}$ max 2 ⑩ ⑨	250 V
$U_{-f/k p}$ max	300 V
$U_{+f/k}$ max	135 V
$U_{+f/k p}$ max	180 V
$R_{f/k}$ max ⑪	1,0 MΩ
$Z_{f/k}$ max ⑫	0,1 MΩ

4. Ratings for Circuit Design

I_{g2}	≤ ± 5 μA
I_{g4}	≤ ± 25 μA
$R_{m/m'}$	≥ 2 MΩ

5. Capacitances

C_{g1}	approx. 6 pF
C_k	approx. 5 pF
$C_{g3g5a/m}$ max	2600 pF
$C_{g3g5a/m}$ min	1700 pF
$C_{g3g5a/m'}$ max	580 pF
$C_{g3g5a/m'}$ min	380 pF

Black and White Picture Tubes

A 59-22 W

For Replacement

Dimensional Drawings in mm

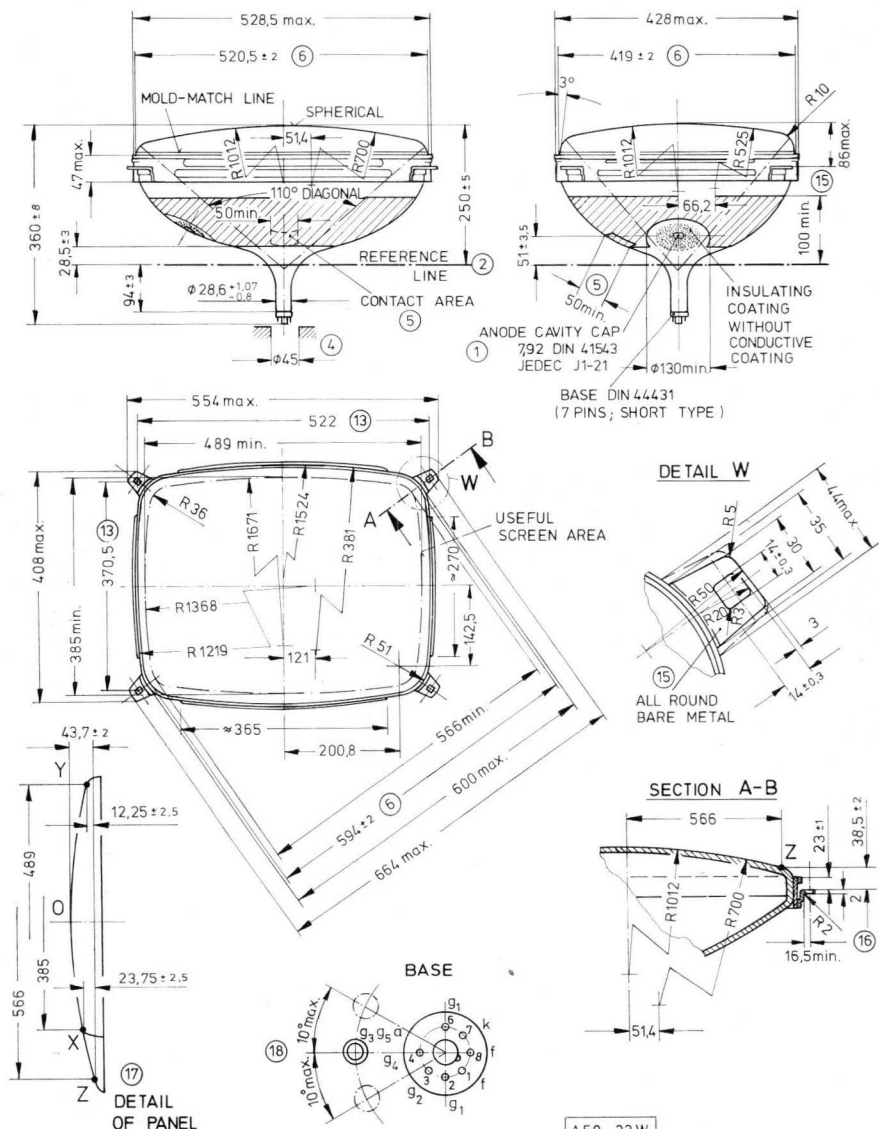

A 59-22 W

O Notes see pages 8 and 9

Reference line gauge see page 11

Black and White Picture Tubes

AW 59-91

For Replacement

59 cm rectangular picture tube with 110° deflection angle, electrostatic focusing and aluminized screen, without steel reinforcement.

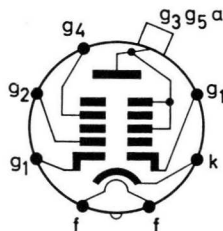

1. Generalities

Electron Gun	Tetrode with Einzel-Lens
Bulb	All-Glass Type
Base	German Standard DIN 44431 (Short Design)
Focusing Method	Electrostatic
Deflection Method	Magnetic
Deflection Angles	Diagonal 110° Horizontal 99° Vertical 82°
Neck Diameter	28.6 mm
Face	Shape Spherical Material Filter-Glass (Light Transmission 75 % approx.)
Screen	Aluminized
Fluorescence Colour	White
Colour Temperature	12 000 °K (approx.)
Minimum Useful	489 x 385 mm
Dimensions	Diagonal 566 mm
Overall Length	358 ± 8 mm
Weight	12 kg (approx.)

2. Typical Operating Conditions

U_f ②	6,3 V
I_f	0,3 ± 6% A
U_{g3g5a}	18 kV
U_{g2}	400 500 V
U_{g4} ③	0 ... 400 0 ... 400 V
$(-U_{g1})_{\text{cutoff}}$ ④	40 ... 77 50 ... 93 V

3. Maximum Ratings

$U_{g3g5a \text{ max}}$ ⑤	18 kV
$U_{g3g5a \text{ min}}$ ⑥	13 kV
$R_{g3g5a \text{ min}}$	16 kΩ
$U_{g4 \text{ max}}$	1000 V
$(-U_{g4})_{\text{max}}$	500 V
$U_{g4 \text{ p max}}$ ⑧	2500 V
$R_{g4 \text{ min}}$	470 Ω
$U_{g2 \text{ max}}$	550 V
$U_{g2 \text{ min}}$	350 V
$R_{g2 \text{ min}}$	470 Ω
$U_{g1 \text{ max}}$	0 V
$U_{g1 \text{ o max}}$	2 V
$(-U_{g1})_{\text{max}}$	150 V
$(-U_{g1})_{\text{p max}}$ ⑧	400 V
$R_{g1 \text{ max}}$	1,5 MΩ
$Z_{g1 \text{ max}}$	0,5 MΩ
$R_{g1 \text{ min}}$	150 Ω
$P_{\text{Im max}}$	10 mW/cm ²
$U_{-f/k \text{ max 1}}$ ⑩ ⑨	410 V
$U_{-f/k \text{ max 2}}$ ⑩ ⑨	200 V
$U_{-f/k \text{ p max}}$	300 V
$U_{+f/k \text{ max}}$	125 V
$U_{+f/k \text{ p max}}$	180 V
$R_{f/k \text{ max}}$ ⑪	1,0 MΩ
$Z_{f/k \text{ max}}$ ⑫	0,1 MΩ

4. Ratings for Circuit Design

$I_{g2 \text{ max}}$	≤ ± 5 μA
$I_{g4 \text{ max}}$	≤ ± 25 μA

5. Capacitances

C_{g1}	approx. 6 pF
C_k	approx. 5 pF
$C_{g3g5a/m \text{ min}}$	1700 pF
$C_{g3g5a/m \text{ max}}$	2500 pF

Black and White Picture Tubes

AW 59-91

For Replacement

Dimensional Drawings in mm

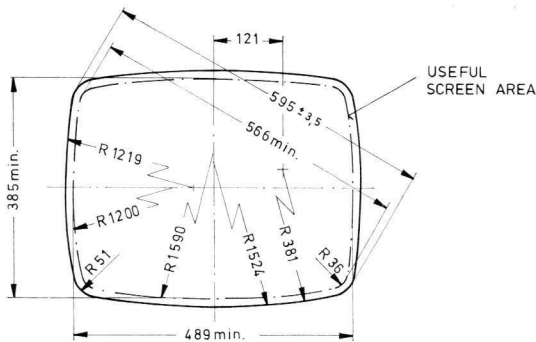
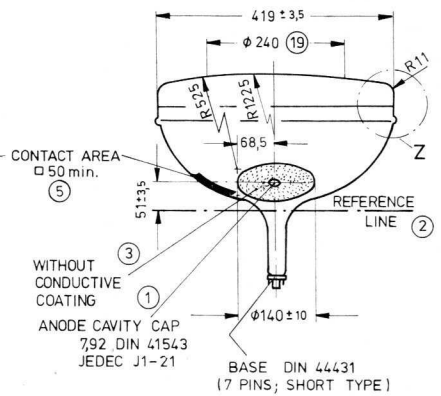
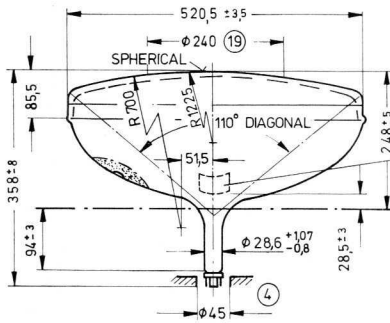

DETAIL Z

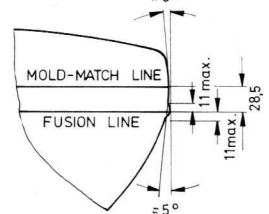

BASE

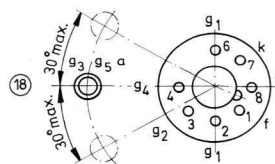

AW 59-91

O Notes see pages 8 and 9

Reference line gauge see page 11

Black and White Picture Tubes

A 65—13 W

For Replacement

65 cm rectangular picture tube with 110° deflection angle, electrostatic focusing, aluminized screen and steel jacket including tube mount

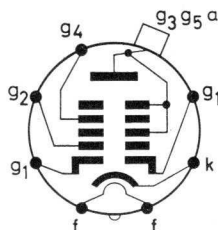

1. Generalities

Electron Gun	Tetrode with Einzel-Lens
Bulb	All-Glass Type
Base	German Standard DIN 44431 (Short Design)
Focusing Method	Electrostatic
Deflection Method	Magnetic
Deflection Angles	Diagonal 110° Horizontal 99° Vertical 82°
Neck Diameter	28,6 mm
Face	Shape Spherical Material Filter-Glass (Light Transmission 40 % approx.)
Screen	Phosphor P4 Alu- minized
Fluorescence Colour	White
Colour Temperature	12 000 °K (approx.)
Minimum Useful Dimensions	530 x 416 mm Diagonal 616,5 mm
Overall Length	383 ± 8 mm
Weight	18 kg (approx.)

Implosion protection by steel reinforcement.
Admitted by Association of German Elec-
trical Engineers, VDE.

2. Typical Operating Conditions

U_f ②	6,3 V
I_f	0,3 ± 6% A
U_{g3g5a}	20 kV
U_{g2}	400 500 V
U_{g4} ③	0 ... 400 0 ... 400 V
$(-U_{g1})$ cutoff ④	40 ... 77 50 ... 93 V

3. Maximum Ratings

U_{g3g5a} max ⑤	20 kV
U_{g3g5a} min ⑥	13 kV
R_{g3g5a} min	16 kΩ
U_{g4} max	1000 V
$(-U_{g4})$ max	500 V
U_{g4} p max ⑧	2500 V
I_{g4} max	25 μA
R_{g4} min	470 Ω
U_{g2} max	500 V
U_{g2} min	350 V
R_{g2} min	470 Ω
U_{g1} max	0 V
U_{g1} p max	2 V
$(-U_{g1})$ max	150 V
$(-U_{g1})$ p max ⑧	400 V
R_{g1} max	1,5 MΩ
Z_{g1} max	0,5 MΩ
R_{g1} min	150 Ω
P_{lm} max	10 mW/cm ²
$U_{-f/k}$ max 1 ⑩ ⑨	410 V
$U_{-f/k}$ max 2 ⑩ ⑨	250 V
$U_{-f/k}$ p max	300 V
$U_{+f/k}$ max	135 V
$U_{+f/k}$ p max	180 V
$R_{f/k}$ max ⑪	1,0 MΩ
$Z_{f/k}$ max ⑫	0,1 MΩ

4. Capacitances

C_{g1}	approx.	6 pF
C_k	approx.	5 pF
$C_{g3g5a/m}$ max		2900 pF
$C_{g3g5a/m}$ min		1900 pF
$C_{g3g5a/m}$ '	approx.	600 pF

Black and White Picture Tubes

A 65-13 W

For Replacement

Dimensional Drawings in mm

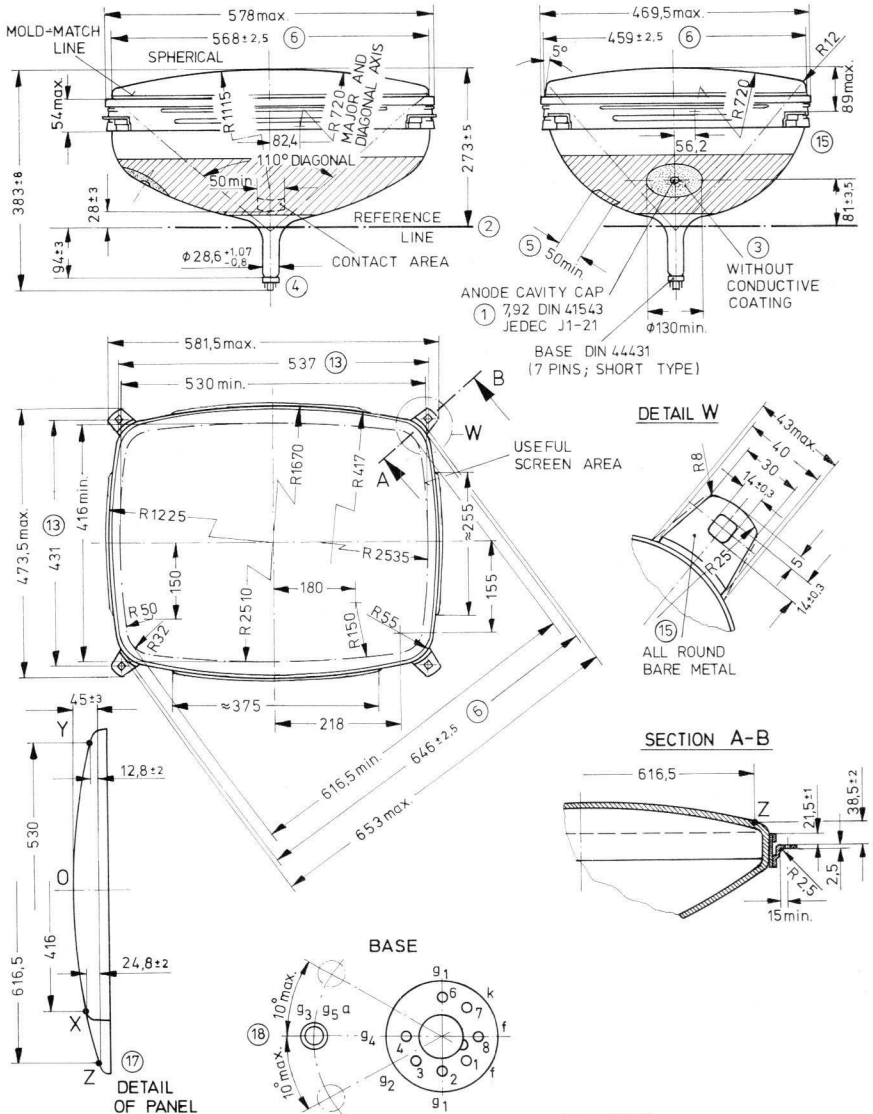

A 65-13 W

O Notes see pages 8 and 9

Reference line gauge see page 11

Black and White Picture Tubes

1. Scope

1.1 General

At least three primary colours are required for the reproduction of colour pictures. In colour television, these are the colours red, green and blue. Depending on the intensity of the individual components other colour combinations can be produced. Therefore, unlike the black-and-white picture tube, the screen must contain three different phosphor materials which can be separately excited. In order to ensure proper scanning and excitation of the colour dots, a perforated metal mask, called shadow mask, is provided behind the phosphor-dot screen.

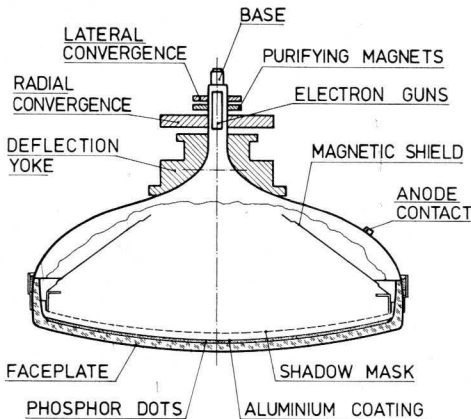

Figure 1: Schematic representation of a shadow-mask tube with associated components

Other techniques are possible but are not described in this booklet, which only deals with the shadow mask tube. This tube, based on the principle of three different colour dots (triplets), has three electron guns using electrostatic focus. One of the three primary colours is assigned to each gun. Proper metal shields are provided

to protect the tube against interfering external magnetic fields (e.g. earth's field).

1.2 Handling colour picture tubes

The information in paragraphs 1.1 through 1.7 regarding storage, transport, packing etc. for the black-and-white picture tubes applies equally in the handling of colour picture tubes. Colour picture tubes are highly sensitive to shock, impact and rapid temperature changes because of the frit seal which joins the panel to the funnel.

1.3 Functional troubles

In addition to the information in paragraph 1.7 for the black-and-white picture tube, colour picture tubes have to be shielded against the influence of external stray magnetic fields. It may be necessary to correct the colour purity when the television set is moved to another location. This readjustment of the television receiver is not an equipment or picture tube defect, but a fine correction of the electron beams striking the screen. The three electron beams are adjusted to land on the screen through the shadow mask at such angles that only the phosphor dots intended for them will be excited. If the electron beams are deflected from their initial path by an interfering stray magnetic field (e.g. earth's magnetic field, transformers, etc.), they will not land on the appropriate phosphor dots. This results in a distortion of the colour content of the received picture, which can be compensated for by the purifying magnets placed on the tube neck.

Colour Picture Tubes

Technical Survey

2. Mechanical and Physical Characteristics of the Colour Picture Tube

2.1 Bulb

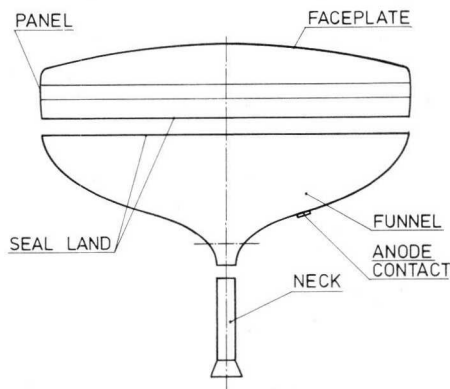

Figure 2: Basic elements of the bulb of a colour picture tube

2.2 Mechanical data

As in the black-and-white picture tube, the bulb of the colour picture tube is made of glass. Unlike the black-and-white tube, however, the panel and the funnel are supplied as single parts which are joined by fritting at the tube manufacturer's plant, **bonding funnel and neck.**

The three main parts of the bulb for colour picture tubes, which are briefly described below, are made as separate units — as in the black-and-white picture tube.

These parts are:

The panel with faceplate, on the inner side of which the phosphor material will be applied later in a highly complex and difficult process and the shadow mask will be fixed. The panel also has four pins (one on each side) for mounting and fixing the shadow mask.

The funnel with sealed-in anode contact, through which the high voltage will be supplied for the three electron guns. The funnel also has three ground faces which

serve for centering purposes during frit-sealing.

The neck, which houses the three electron guns and also carries the deflection yoke.

2.3 The panel

With the colour picture tube it is essential that the skirt of the panel be smooth, since after application of the phosphor material and fixing of the shadow mask in the panel, this surface is joined to the funnel at high temperatures by frit-sealing. The bulb of the colour picture tube has thicker walls than those of the black-and-white tube, so that a 20-inch colour tube is heavier than a corresponding black-and-white tube. Similar to the funnel, the panel has three ground marks on its outer surface, which serve as reference marks during frit-sealing and assembly of the electron guns.

2.4 The funnel

In all types of colour picture tubes the funnel is made of glass. The deflection angle is 90° or 110° . The anode contact sealed into the small face of the funnel serves, in the finished tube, for feeding the high voltage to the electron guns. As with the black-and-white picture tube, the funnel serves as the link between the screen and the neck of the tube. The edge facing the panel must also be very accurately machined in order to ensure a durable, vacuum-sealed joint between the two parts when the panel is fritted to the funnel.

2.5 Physical data on the colour picture tube

Regarding absorption, contrast and halo the same applies as in the black-and-white picture tube. Some types of colour picture tubes have an integral protection window sealed to the faceplate with a clear resin. This PPG window is tinted

Colour Picture Tubes

Technical Survey

gray. External stray light has to pass the window twice due to reflection on the screen, while the light from the screen suffers considerably less absorption because it only passes the window once.

In future colour picture tubes, a special filter glass will be used as faceplate material offering high light transmittance to the wavelengths of the three primary colours but absorbing most of the other wavelengths. Through this method an improvement in the contrast of the colour picture will be achieved.

2.6 The screen

The screen of a shadow-mask colour picture tube consists of a large number of adjacent dots, approx. 1,2 million phosphor dots in the case of a 66 cm (26") tube, each 0,4 mm (0,0157") in diameter and 0,020 mm (0,00079") thick. Zinc sulphides, which are activated by traces of heavy material and rare earth oxides, are used as phosphor material. By means of these activators the zinc sulphide crystal is converted into a semiconductor. When energy is applied to the semiconductor material this can be excited into emitting a particular light wavelength. The phosphor material is not only excited by fast electrons but also by ultraviolet radiation. This light stimulation is used for the numerous inspections during the manufacture of the screen. Three adjacent colour dots on the screen of the colour picture tube form a colour triplet (see figure 3) comprising a red, a green and a blue light emitting dot.

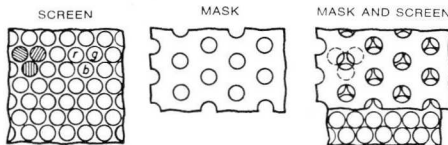

Figure 3: Screen and mask of a shadow-mask type colour picture tube

A hole in the shadow mask corresponds to each colour triplet. Each of the three electron beams passing through this hole excites one of these phosphor dots (see figure 3). By additive mixing of the three primary colours the desired colour impression is obtained. Since the hole diameter in the mask and, hence, that of the individual electron beam is smaller than the diameter of a dot (0,3 mm [0,0118"] as against 0,4 mm [0,0157"]), accurate registration is ensured, preventing one beam (e.g. the red beam) from exciting part of the area of the other two phosphor dots and causing colour purity errors.

During the manufacture of the screen a light-sensitive substance (polyvinyl alcohol) is added to the respective phosphor material, e.g. green, and is then applied to the tube panel. Then, by means of an intensive punctiform ultraviolet light source and with the shadow mask as a matrix, a dot pattern is exposed in the tube panel. At the exposed areas the polyvinyl alcohol polymerizes, thereby bonding the phosphor material to the glass surface. It is washed away with water on the remaining surface which has not been exposed. The same process is repeated in an analogous manner for the other two colours. In the process the light source is placed in the future location of the beam deflection point. Thus a pattern of triangular groups of three small phosphor dots is produced on the screen. It is essential that the individual phosphor dots are adjacent to each other without overlapping, which would result in colour contamination.

2.7 Aluminization

Structure and purpose of the aluminium coating in the colour picture tube are the same as in the black-and-white picture tube.

2.8 Colour vision

The retina of the human eye contains rods for registering differences in brightness

Colour Picture Tubes

Technical Survey

and less sensitive cones for colour impression. Different types of cones react in different ways to light of the same wavelength and intensity. Only the sum of all stimuli provides the impression of colour. This makes it possible to perceive the same colour in spite of different spectral compositions of the light. Thus, by mixing any three independent primary colours in various proportions, it is possible to produce all the other colours (the human eye is able to differentiate between some 1 million colours).

For practical reasons three colours are chosen as primary colours which are as far separated in the frequency spectrum as possible, e.g. red, green and blue. This combination is used in colour television for the reproduction of the vast multitude of colours.

2.9 Colorimetry

For the clear determination of a colour, a scheme is used in which the three primary colours are arranged at the vertex of an isosceles triangle. Each colour corresponds to a specific point of the triangle, the so-called spectrum locus. The spectrum locus is a measure of the shade. A second characteristic of colour is the **saturation**. The saturation reaches the maximum value of 1, e.g. for a saturated red, and decreases, as white increases, via pink to zero (white or grey). Shade and saturation are often expressed by the term **chromaticity**. A third element for the description of the colour is the **brightness**. For primary source elements (the screen is considered a primary source) the luminance is a direct measure of the brightness.

2.10 Influence of colour area and surroundings

A colour impression can only be obtained if several cones in the retina are stimulated. If the angle at which a coloured area is

viewed by the eye is smaller than $6'$, only a brightness impression is produced. When a large number of very small colour dots are close together, the human eye is only able to record the compound colour. The diameter of the phosphor dots has been chosen so that at a normal viewing distance the compound colour is perceived by the observer's eye.

The above holds true only if the observed area is situated in a sufficiently dark room. If the surrounding room is considerably brighter than the screen area, all colours appear as if black were added to them. Therefore it is essential for good colour television reception that the ambient room be sufficiently dark in order to ensure good colour fidelity.

2.11 The shadow mask

The purpose of the shadow mask in a colour picture tube is twofold. During the manufacture of the screen it serves as the negative for the three colour rasters. In the finished tube it serves as diaphragm for the deflected electron beams, allowing each beam to land only on the associated phosphor dots.

The mask consists of a sheet-steel plate which is 0,15 mm (0,0059") thick and contains about 400 000 round holes, each 0,3 mm (0,0118") in diameter. The shape of the mask is matched to the curvature of the faceplate. The average distance from the faceplate of the picture tube is about 13 mm ($1/2''$). This distance is im-

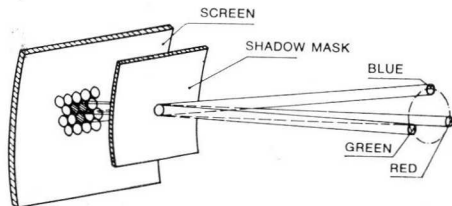

Figure 4: Beam traces in a shadow-mask type colour picture tube

portant for good colour reproduction (colour purity) (see figure 4). If the specified distance is not accurately maintained, electron beams which are assigned to a particular colour raster might excite neighbouring phosphor dots, which would result in colour impurities.

The transparency of the shadow mask is about 17%. As a result the mask has to dissipate power during the absorption of the electron beams that cannot be neglected. Assuming a mean continuous beam current of 1 mA at 25 kV, which is still tolerable, this power dissipation amounts to about 22 W. As a result the mask will be heated and will expand. Since it is not possible to transfer the occurring heat quickly enough by heat conduction, the mask is blackened by an oxidation process, thus improving the heat radiation. At high beam currents (max. 1,5 mA), however, this is no longer sufficient. But even under these conditions the movement of the mask holes due to temperature influence is still compensated for in modern colour picture tubes. The holding springs which fix the mask in the screen panel are

so arranged that the mask moves towards the screen when heated. This ensures that the movement of the mask holes does not exceed the permissible value.

2.12 Electron gun assembly

In a colour picture tube, three electron guns are used for the generation of the electron beams. The design of each individual electron gun is similar to that in a black-and-white picture tube. Instead of the einzel-lens however, a bi-potential lens is used. The reason for this is the required high dielectric strength (high anode voltage) at small gun diameter. The bipotential lens is formed by the electrostatic field between screen grid, focus and anode electrode. In the case of the electron guns for colour picture tubes, the three cathodes, control grids and screen grids are brought out separately, while the focus electrodes and the anodes are interconnected within the tube. The focus electrodes are joined to a base pin and the anodes receive their anode supply voltage via the anode contact sealed into the funnel.

Colour Picture Tubes

Technical Survey

3. Principle of Operation of the Shadow-Mask Type Colour Picture Tube

3.1 Principle of the colour picture tube

In the shadow mask type colour picture tube three electron beams are generated independently of each other. Due to the straight propagation path of the electrons in free space, each beam would excite only one point on the phosphor-dot screen into light emission. For this reason the electron beams have to be deflected from their straight path across the whole screen, as in the black-and-white picture tube. In order for each beam to hit the associated phosphor dots on the screen in spite of the distortions due to the deflection yoke, a so-called dynamic convergence unit is needed, which ensures that the triplet geometry is directly reproduced on the mask. By intensity modulation of the individual electron beams, the different colour phosphor dots on the screen are excited with varying intensities, depending on the picture content to be transmitted. By additive mixing of the excited primary colours — red, green and blue — the transmitted colour picture is reproduced on the screen. An essential factor for good colour reproduction is the so-called colour purity. This is the requirement that each electron beam of an electron gun in a three-colour system only be allowed to excite the phosphor dots of the associated colour. This is ensured by the absorption effect of the shadow mask. As a result, however, current is continuously flowing in the mask during operation, which causes it to run hot. The resulting expansion of the shadow mask would cause a movement of the mask holes with respect to the colour phosphor dots. This thermal movement of the mask is compensated for by a corresponding fixing arrangement.

The design of the electron guns is similar to that of the black-and-white picture tubes. Unlike the black-and-white picture tube, however, bi-potential lenses are used for electrostatic focusing instead of einzel-

lenses. With the exception of the combined lens electrodes, the control electrodes of the three electron guns are brought out individually, so that optimum adjustment of the colour triplet register and of the brightness are possible.

3.2 Electrical characteristics

Since the colour picture tubes differ in principle only negligibly from the black-and-white picture tubes, it is sufficient to point out some design and functional differences and the resulting consequences for application.

3.3 Limit value of the overall anode current for the three electron guns

It is an inherent functional characteristic of the shadow-mask principle (see paragraph 2.11) that about 80% of the anode current is absorbed by the mask where it is converted into heat. At an anode voltage of 25 kV and an overall anode current of 1,25 mA the mask is loaded with about 80% of the resulting dissipated power, i.e. 25 W. Therefore, by limiting the anode current to a maximum permissible value in addition to choosing a suitable mask design, it must be ensured that no undue displacement of the mask with respect to the screen will take place when the mask is heated during operation. This would be detrimental to the colour purity. Experience has shown that a limitation of the beam current for the three electron guns to 1,5 mA (arithmetic mean value) in a picture tube with 66 cm (26") screen diagonal has proved satisfactory.

3.4 Flashovers

Since colour picture tubes operate with a considerably higher anode voltage than black-and-white picture tubes, the anode voltage and grid-No. 3 voltage supplies should be so rated that the current

produced at flashovers and short-circuits is limited to a maximum value in order to avoid damages to the cathode. Particularly exposed electrodes in the colour picture tube, such as grid-No. 3, grid-No. 2, grid-No. 1 and the cathode, are suitably protected by spark gaps connected to the external conductive coating of the tube. The connection with the external coating should be made with great care and using the shortest possible leads.

3.5 Interfering magnetic fields

In order to shield the tube against the disturbing influence of stray magnetic fields which may affect colour purity, the manufacturer recommends the use of a metal shield (sheet steel) over the funnel between the metal frame reinforcement and the deflection yoke if the tube is not supplied with an inner magnetic shield. Furthermore, colour purity errors may also be produced by residual magnetism of the shadow mask which may be due to transport or storage. This residual magnetism can easily be removed by degaussing the shadow mask by means of an air-core coil, through which an exponentially decreasing alternating current with a frequency of 50 Hz flows. Modern television receivers already incorporate a degaussing coil which is automatically connected into circuit when the set is turned on.

3.6 Initial operation and adjustment of the colour picture tube

The basic conditions for accurate adjustment of the colour purity and convergence are:

- a) The focus of the three electron guns must be optimally adjusted, which is achieved by the application of a direct voltage to grid-No. 3.
- b) The colour picture tube must have been previously degaussed. This is done automatically by means of a degaussing coil when the set is turned on. This removes local colour impurity areas, which

may be due to the magnetization of the metal frame and the mask.

- c) The use of crosshatch or dot video patterns for the convergence adjustment. The following sequence should be observed for this adjustment:

3.7 Adjustment of static convergence

By means of the radial permanent magnets or electromagnets and the lateral converging unit the red, green and blue patterns must be made to coincide at the centre of the screen. Normally the blue beam is turned off first while the red and the green patterns are aligned. Optimum adjustment is obtained if a yellow raster appears at the centre of the screen. The blue beam is then turned on and aligned with the yellow raster by means of the respective magnets.

3.8 Colour purity

Move the deflection yoke as far back as possible towards the convergence unit.

With the red raster on, the most possible uniform red field is adjusted in the centre of the screen by turning and adjusting the two colour purity magnets on the convergence unit. Then the deflection yoke is moved forward until a uniform red field is observed over the entire screen.

The colour purity of the green and blue raster is then checked. In order to achieve optimum colour purity for the red, green and blue rasters, it may be necessary to make some compromises. The static convergence has to be checked before and after each colour purity adjustment.

3.9 Dynamic convergence

For the adjustment of the dynamic convergence a bright crosshatch or dot video pattern is needed. The intensity of the three colours should be approximately the same. By varying the line and raster frequency alternating currents flowing through the convergence coils, the three

Colour Picture Tubes

Technical Survey

colour rasters must be made to coincide over the entire screen, so that only white dots or raster lines are observed. First the red and green lines or dots are aligned. Then the blue raster is adjusted to the yellow one produced by convergence of the red and green rasters. During the adjustment of the dynamic convergence it is recommended that the colour purity and the static convergence be checked repeatedly and readjusted if required.

4. Implosion Protection

4.1 Purpose of the implosion protection

The information and definitions given in paragraph 2 for the black-and-white picture tube apply for the implosion protection of the evacuated colour picture tubes.

4.2 Implosion protection by means of metal frame

As in the black-and-white picture tube, implosion protection can be achieved for the colour picture tubes by the application of a metal frame over the critical zones. To accomplish this the space between the correspondingly shaped met-

3.10 Pincushion correction

Correction of the vertical and horizontal pincushion distortion is performed by means of a transducer. The horizontal correction is achieved by modulation of the horizontal deflection current with the vertical frequency; vertical correction is achieved by modulation of the vertical deflection current with the horizontal frequency.

al frame and the tube is filled with a sealing and filling material. After cooling, the shrinking of the assembly provides the desired implosion protection.

4.3 Implosion protection according to the SELBOND® method

The SELBOND method is a variation of the metal frame. By means of the SELBOND method the critical zones of the tube are prestressed to an adjustable, measurable value. In addition it permits push-through presentation with a corresponding reduction in the metal frame dimensions.

5. Manufacturing a Colour Picture Tube

As has already been mentioned in the functional description of the shadow-mask type colour picture tube, the colour picture tube differs in four essential aspects from a black-and-white picture tube; namely the existence of a shadow mask, the screen with phosphor dot pattern, the two-piece bulb and the three electron guns. These differences are also reflected in the production process. Figure 5 shows a schematic representation of the sequence of manufacturing operations.

The washed panels arrive at the automatic screening machine, where they are clamped on a holding device and rotated. By means of a dispensing and control unit the light-sensitive green phosphor slurry is filled into the centre of the panel. Due to the rotation of the panel the slurry spreads uniformly over the entire screen surface. The phosphor coating is then dried by means of ultrared radiators and the coated panels are transferred to the green lighthouse. There a shadow mask

Colour Picture Tubes

Technical Survey

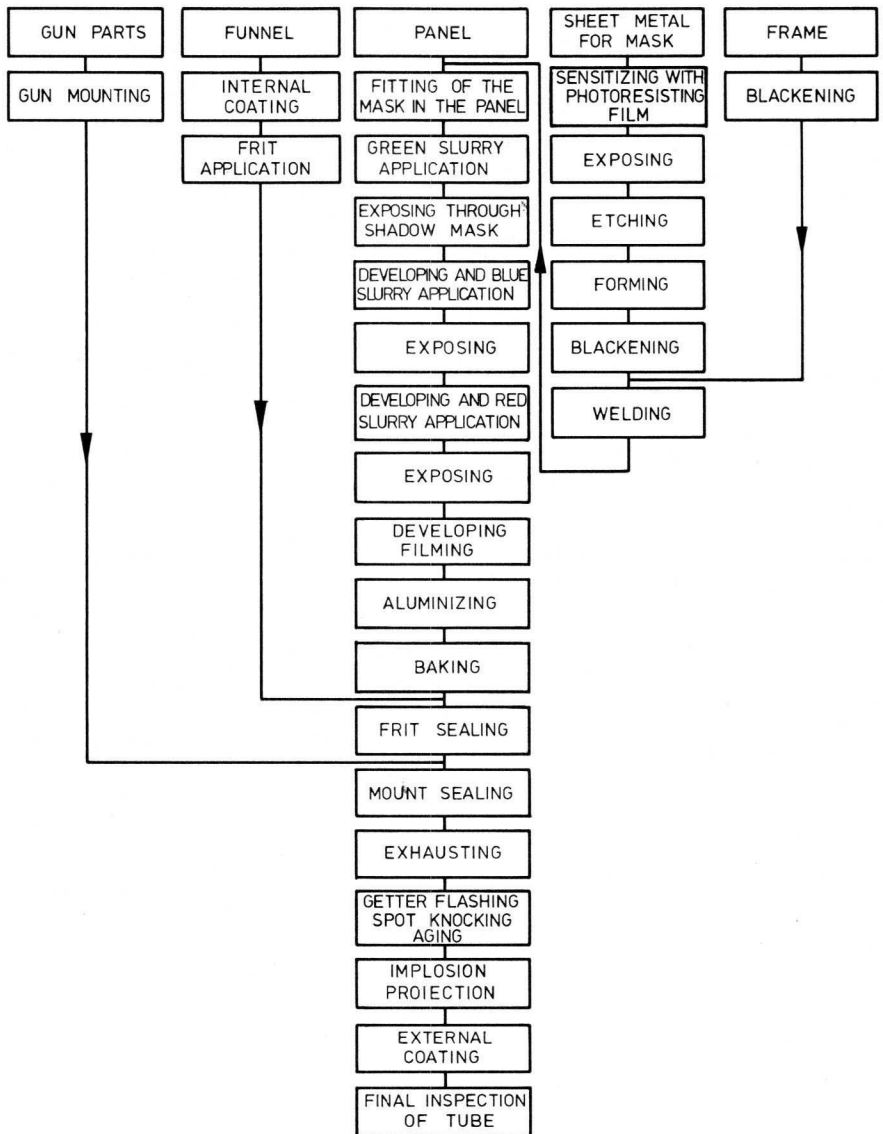

Figure 5:
Schematic representation of the
manufacturing process

Colour Picture Tubes

Technical Survey

is assigned to each panel. During the exposure and in the finished tube, the same mask must be used since, due to manufacturing tolerances, it is not possible to achieve the required 10 μm accuracy of reproduction if different masks are used. The shadow mask is produced according to a method which is closely related to photo-printing. After the sheet metal has been chemically cleaned of surface contamination it is coated on both sides with a light-sensitive film similar to that used in photography. The coated metal sheet is then pressed between two plane glass plates which contain the desired hole pattern and which are required to coincide to an accuracy of some microns from one side of the sheet to the other.

Two high intensity arc lamps, arranged on either side of the mask, are used for the exposure itself. After exposure, the pattern is developed and the remaining film is hardened in an oven. Then the holes are etched into the metal sheet from both sides by means of an acid shower. Finally the remaining light-sensitive layers and acid are removed and the mask is brought into its definite shape by means of a forming tool. Prior to the precision welding of mask and frame both parts are blackened by an oxidation process.

For the exposure of the phosphor layer the panel with the inserted mask is placed on the lighthouse. Since the location of the exposed dots is fixed by lighting with a punctiform ultraviolet light source, it is necessary for the position of the panel with respect to the light source to be closely maintained. To this end ground surfaces on the edge of the panel are

made to coincide with reference points on the lighthouse. Then after exposure the mask is removed again and the panel goes back to the automatic screening machine. There the panel is again rotated and the unexposed areas of the phosphor layer are washed away with warm water (see also paragraph 2.6). Then the blue and the red phosphor slurry is dispensed, using each time the same procedures as described in the application of the green phosphor slurry. After the screening procedure, the filming and aluminizing processes follow, as for the black-and-white picture tube. To remove the organic materials (film, phosphor binder) the panel is baked in air.

Before frit sealing, the shadow mask is fitted into the tube panel for the last time. The glass solder is applied to the sealing surfaces of the funnel, which is coated on its inner side with a graphite layer, and funnel and panel are placed into a device which serves to align the two parts accurately by means of stops and to hold them in place during frit-sealing. The assembly is then passed through an oven in which the frit is changed into a glassy state, thus producing a vacuum-tight joint of high mechanical strength between panel and funnel.

Finally, sealing of the electron gun assembly follows; its orientation must be in agreement with the configuration of the colour triplets. The remaining operations and tests involved in the tube manufacture are similar to those of the black-and-white picture tube and constitute the end of the production process.

6. General

6.1 X-rays

At a maximum permissible anode voltage of 27,5 kV and an average beam current of 1,5 mA X-radiation remains below the maximum permissible value of 0,5 mR/h.

6.2 Mounting instructions

Metal frame:

The mounting lugs on the metal frame are provided for fixing the tube in the television set. For the respective dimensions, reference is made to the dimensional outline.

External conductive coating:

The external conductive coating should be connected by means of multiple contacts in order to avoid overheating of a contact and consequent damage to the tube.

Metal frame and external coating are electrically isolated from each other. They may be joined if the applicable safety rules permit this. The impedance between the frame and the external coating should not exceed 1 M Ω at 50 Hz and 5 k Ω at 15 kHz.

Tube socket:

A flexible connection should be used for the tube socket. The base is allowed to be within a circle of 20 mm ($25/32''$) diameter, with reference to the perpendicular through the centre of the screen.

Anode contact:

The area around the anode contact is sprayed with transparent water-repellent paint. Only a dry, soft, lint-free cloth should be used for cleaning it.

Operating position:

The tube must be operated with its axis in a horizontal position and with the blue electron gun up. The data concerning beam deviation and convergence apply to this operating position.

The deflection yoke must not be used to support the tube.

6.3 Application instructions

Voltage reference point:

Unless otherwise specified, the voltage values refer to cathode potential and apply to each individual electron gun.

Focus electrode:

At an anode voltage of 20 to 27,5 kV, for the focus electrode g_3 a voltage has to be set amounting to 17 to 20% of the anode voltage.

Operating point adjustment:

The grid-No. 2 and grid-No. 1 voltages for disappearance of the focused spot (cutoff voltage) can be derived from the cutoff design chart.

Cutoff Design Chart

A 55-14 X
A 63-11 X
A 63-200 X

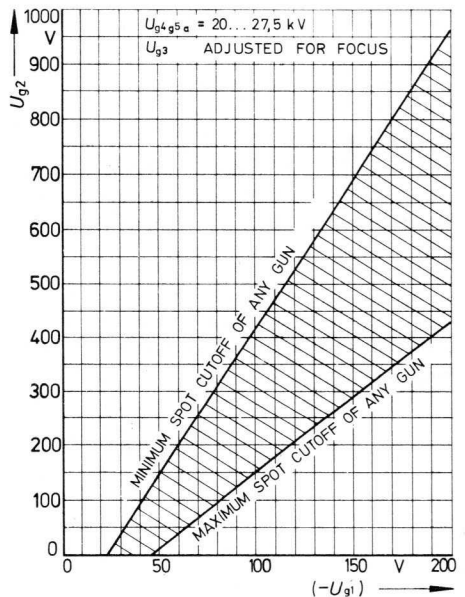

Colour Picture Tubes

Technical Survey

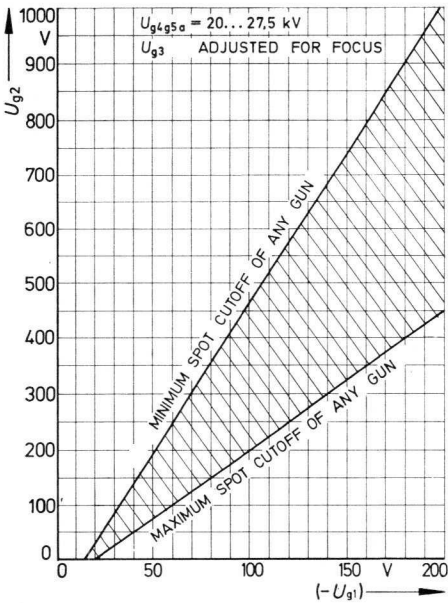

Cutoff Design Chart A 56-120 X
 A 66-120 X
 A 66-140 X
 A 66-410 X

Grounding:

The external conductive coating and the external magnetic shield have to be connected to the negative high-voltage terminal.

Flashover protection:

In order to avoid possible damage to the tube due to internal flashovers, a suitable current limitation is recommended in high-voltage supplies for the anode and grid-No. 3, as well as the use of spark gaps.

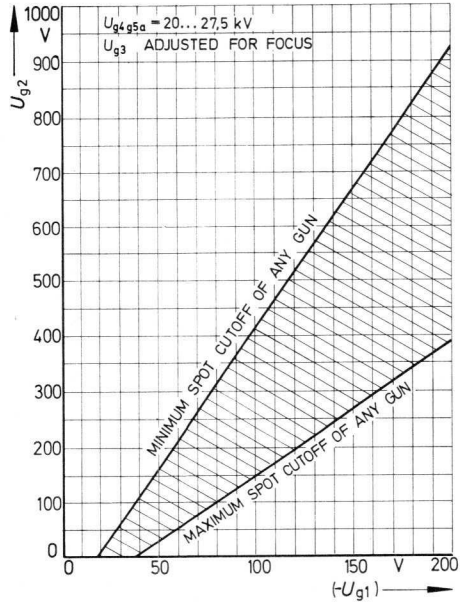

Cutoff Design Chart A 67-150 X
 A 67-510 X

Maximum ratings:

The circuit should be so rated that the indicated maximum ratings are not exceeded during tube life, even under the worst possible operating conditions with regard to supply voltage variation, signal variations, component tolerances and ambient conditions.

The high-voltage maximum ratings are absolute values which must not be exceeded even when the tube is first placed in operation. Do not connect the tube before the high voltage is adjusted within the specified limits.

Colour Picture Tubes

Technical Survey

Beam landing correction:

In spite of external or internal magnetic shield and due to manufacturing variations which may produce misregister, it is necessary for pure colour operation to correct for remaining magnetic effects and for manufacturing variations by an additional static magnetic field (purifying magnet).

Position of the components for convergence adjustment, see dimensional drawings for the different types.

Ratser deviation referred to the centre of screen: max. R mm.

Lateral (seitliche) convergence deviation blue beam to converted red and green beams: max. s mm.

R(r)adial convergence deviation without effect of the dynamic convergence (each beam): max. r mm.

	R	s	r
A 66-120 X	15	$\pm 6,5$	$\pm 9,5$
A 66-140 X	15	$\pm 5,0$	$\pm 8,0$
A 67-150 X	12	$\pm 5,0$	$\pm 8,0$
A 55- 14 X	12	$\pm 6,0$	$\pm 9,5$
A 56-120 X	12	$\pm 6,0$	$\pm 9,5$
A 63- 11 X	15	$\pm 6,5$	$\pm 9,5$
A 63-200 X	15	$\pm 6,5$	$\pm 9,5$

Colour Picture Tubes

Technical Survey

Typical grid-drive characteristics

Grid-drive characteristics

U_f	6,3 V
$U_{g4g5a/k}$	20 to 27,5 kV
$U_{g3/k}$	adjusted for focus
$U_{g2/k}$	adjusted for each gun to provide spot cutoff for desired fixed
	($-U_{g1/k}$)

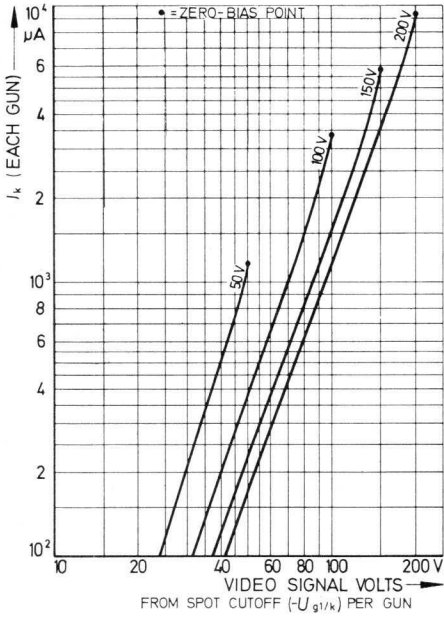

A 55— 14 X
 A 63— 11 X
 A 63—200 X

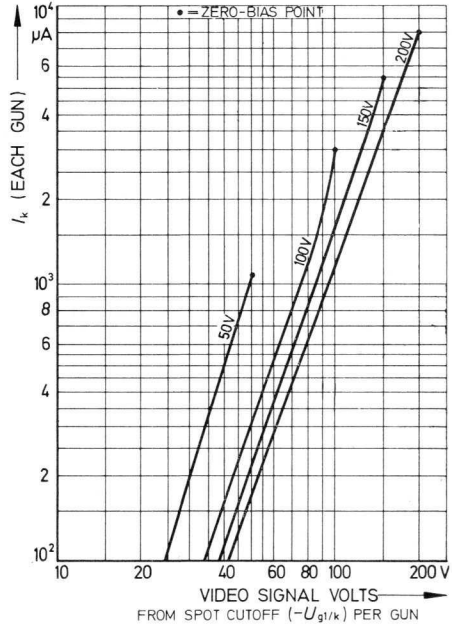

A 56—120 X
 A 66—120 X
 A 66—140 X
 A 66—410 X

Colour Picture Tubes

Technical Survey

Typical cathode-drive characteristics

Cathode-drive characteristics

U_f 6,3 V

$U_{g4g5a/g1}$ 20 to 27,5 kV

$U_{g3/g1}$ adjusted for focus

$U_{g2/g1}$ adjusted for each gun to provide spot cutoff for desired fixed ($U_{k/g1}$)

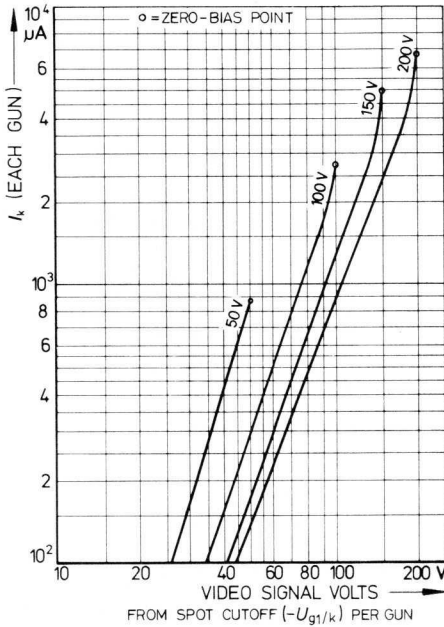

A 67-150 X
A 67-510 X

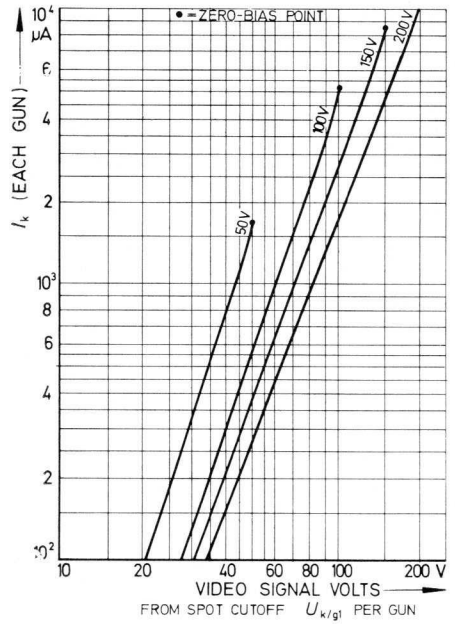

A 55-14 X
A 63-11 X
A 63-200 X

Colour Picture Tubes

Technical Survey

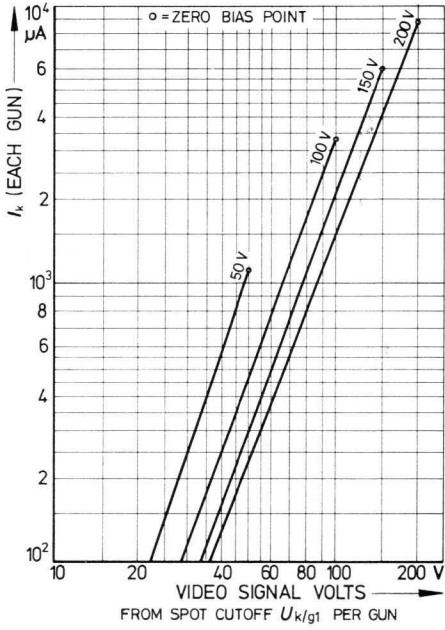

- A 56-120 X
- A 66-120 X
- A 66-140 X
- A 66-410 X

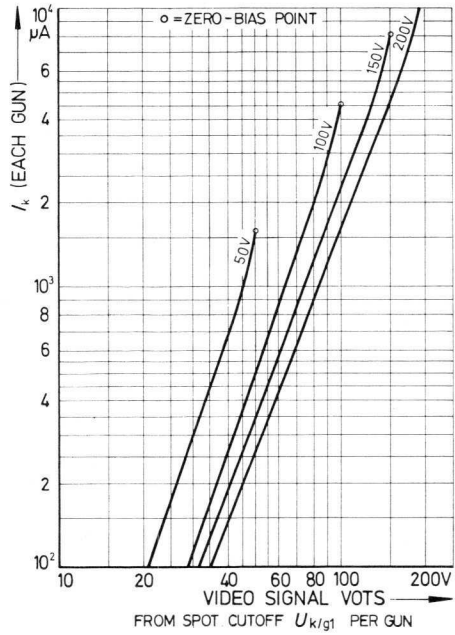

- A 67-150 X
- A 67-510 X

6.4 Associated components

Deflection yoke

The deflection yoke must not be used to support the picture tube. The axes of the deflection yoke and of the tube must coincide. The deflection coils should be able to be moved about 1,5 cm ($5/8''$) along the tube neck for the adjustment of colour purity. The deflection yoke should be able to be rotated slightly. Centering of the raster can be made by superimposing a direct current of the required magnitude on the deflection current through each coil pair. Pin-cushion correction can be achieved by superimposing of a correspondingly shaped correcting current on the deflection current.

Colour purity magnet

The colour purity magnet is required in order to compensate for the effects of uniform external magnetic fields that would cause beam landing errors. The colour purity magnet must be placed on the tube neck as indicated in the data sheets. For varying the beam landing point, the produced magnetic field should be at right angles to the tube axis and should be adjustable in magnitude and direction. By means of the colour purity magnet it must be possible to adjust all indicated tolerance values.

Magnetic shield

To reduce the effects of external stray magnetic fields and of the earth's magnetic field, a cold-rolled steel sheet of about 0,75 mm (0,0295") should be placed as a shield around the funnel of the tube, provided the tube has no internal shield. The shield is only effective if the metal sheet is degaussed. This is possible by means of a degaussing coil which is automatically connected into circuit when the television set is turned on. In order to

avoid weakening the magnetic field excessively during degaussing, the air gap between shield and metal frame as well as between shield and funnel should not exceed 10 mm ($25/64''$).

Radial convergence unit

The radial convergence unit, in conjunction with the associated circuit, produces the magnetic fields which are necessary for the dynamic convergence of the three electron beams when moving over the screen. In addition, the radial convergence unit, together with the lateral convergence unit, generates the magnetic fields needed for the static convergence. The three convergence magnets are fitted on the neck of the tube in such a manner that they face the pole pieces within the tube neck. The requisite horizontal and vertical currents flow through the associated windings of the convergence unit thus ensuring the dynamic convergence of the deflected beams. Static magnetic fields for the convergence of the three beams at the centre of the screen are produced either by direct currents in the convergence windings or by magnets with variable field strength. The radial convergence unit must be able to adjust the indicated tolerance values.

Lateral convergence unit

The lateral convergence unit serves to complement the correction of the static convergence of the three electron beams at the centre of the screen performed by the radial convergence unit. It is fitted on the neck of the tube between the colour purity magnet and the radial convergence unit. The task of the magnetic field is to produce a lateral (horizontal) movement of the blue beam opposite to the movement of the converged red and green beams. Therefore the magnetic field strength must be variable to permit adjustment of the indicated tolerance values.

Colour Picture Tubes

Technical Survey

6.5 Reference line gauge

The reference line is determined by the flange plane of the reference line gauge, if it is seated against the funnel of the bulb.

Reference line and neck-funnel-contour gauge

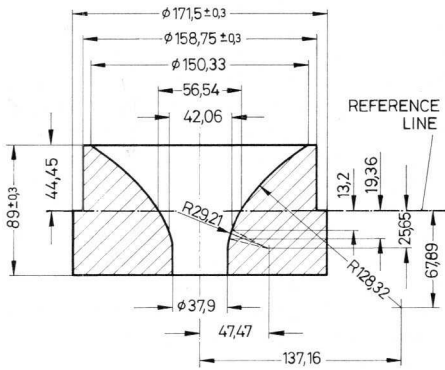

for colour picture tubes
 A 55-14 X
 A 56-120 X
 A 63-11 X
 A 63-200 X
 A 66-120 X

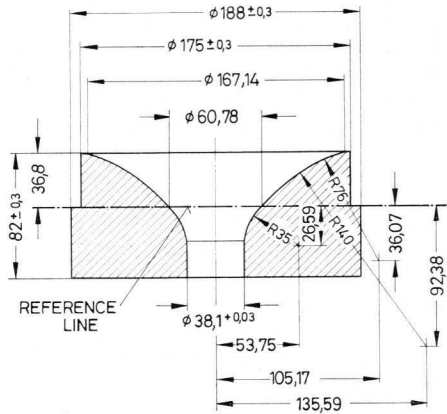

for colour picture tubes A 66-140 X
 A 66-410 X

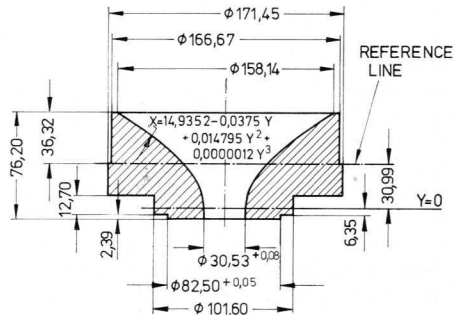

for colour picture tubes A 67-150 X
 A 67-510 X

Colour Picture Tubes

Technical Survey

6.6 Optical Data

Screen

Three Separate Phosphor Dots — Colour-Triplets — Arranged in Triangular Groups and Aluminized.

Colour Dot Coordinates	x	y
Red	0,630	0,340
Green	0,300	0,600
Blue	0,150	0,060
Coordinates for White	0,281	0,311

Average Percentage of Total Cathode Current to Produce White

Red	34 %
Green	34 %
Blue	32 %

Ratio of Cathode Currents for White

Red to Green	1,0	(0,65 ... 1,5)
Red to Blue	1,1	(0,75 ... 1,5)
Blue to Green	0,9	(0,6 ... 1,3)

7. Explanation of Symbols for the Quantities Listed Under Electrical Data

7.1 Typical Operating Conditions

Heater Voltage	U_f
Heater Current	I_f
Anode Voltage	U_{g4g5a}
Focusing Voltage	$U_{\alpha 3}$
Screen Grid Cutoff Voltage	$U_{g2 \text{ cutoff}}$
Control Grid Voltage	$(-U_{g1})_{\text{cutoff}}$

7.2 Maximum Ratings

Anode	
Voltage	U_{g4g5a}
Current	I_{g4g5a}
Focusing Electrode	
Voltage	U_{g3}
Screen Grid	
Voltage	U_{g2}
Peak Voltage	$U_{g2 p}$
Control Grid	
Voltage	U_{g1}
Peak Voltage	$U_{g1 p}$
Heater/Cathode	
Voltage	
Heater —	
During Warm-Up Time	$U \pm_{f/k} (1)$
Heater —	
After Warm-Up Time	$U \pm_{f/k} (2)$
Heater —	
Peak Voltage	
After Warm-Up Time	$U \pm_{f/k p}$

7.3 Ratings for Circuit Design

Leakage Current	I_{g3}
	I_{g2}
	$I_{g1} (-U_{g1} = 150 \text{ V})$

7.4 Capacitances

Between Control Grid of One Gun and All Other Electrodes	C_{g1}
Between Cathode of One Gun and All Other Electrodes	C_k
Between Grid No. 3 and All Other Electrodes	C_{g3}
Between Anode and External Conductive Coating	$C_{g4g5a/m}$
Between Anode and Metal Frame	$C_{g4g5a/m'}$

Colour Picture Tubes

Technical Survey

8. Notes

8.1 On the technical data

- ① For grid-drive service. The voltage values refer to cathode potential and apply to each individual gun.
- ② Maximum heater voltage variations of $\pm 10\%$ are tolerated, optimum cathode life is achieved by stabilization of the heater voltage at 6,3 V.
- ③ The ratio between the maximum and the minimum cutoff voltage at grid-No. 2 of an individual gun does not exceed the value of 1,86 with equal control grid voltage.
- ④ Visual extinction of focused spot, see Cutoff Design Charts, pages 59 and 60.
Relation: line cutoff voltage = spot cutoff $\times 1,01 + 1$ V,
raster cutoff voltage = spot cutoff $\times 1,05 + 7$ V.
- ⑤ If the anode current exceeds the nominal value for a prolonged period of time, deformation of the shadow mask may occur due to thermal overloads, which will result in colour purity errors. Beam current limitation to 1,5 mA for the three-gun assembly is sufficient for practical purposes.
- ⑥ Absolute limit value which must not be exceeded even under the worst possible operating conditions.
- ⑦ These values indicate the leakage currents that may occur at the respective electrodes. Their influence on the voltage across the electrode concerned has to be taken into consideration in the design of the circuit.
- ⑧ The circuit design of the equipment – both from a mechanical and electrical viewpoint – should be such that no energy source, alone or in connection with others, can cause a discharge current greater than 750 mA to flow through the heater as a result of a flashover.
The current limitation prevents the heater from burning out in the case of a flashover within the colour picture tube.
- ⑨ In order to avoid picture distortions the hum component from the heater circuit should be as low as possible. Therefore the alternating voltage between heater and cathode should not exceed the effective value of 20 V.
- ⑩ During the warm-up period of max. 15 seconds $U_{-f/k 1}$ may rise to max. 410 V (450 V). Between 15 and 45 seconds after switch-on the voltage must decrease proportionally with time to the value recorded in the data book.
- ⑪ By using a quick heating cathode the picture will appear in 5 seconds approx., when applying a constant heater voltage.

8.2 On the dimensional drawings

- ① Anode cavity cap according to German Industrial Standard DIN 41 543.
- ② The reference line is determined by the flange plane of the reference line gauge if it is seated against the funnel.
- ③ This zone is free of external conductive coating.
- ④ Location of the inner pole pieces of the gun for radial convergence.
- ⑤ For the mounting bolts a free passage of at least 9,5 mm ($\frac{3}{8}$ ") diameter is guaranteed in nominal position.
- ⑥ Dimensions of the bulb, measured at the front edge of the implosion protection.
- ⑦ The maximum deviation of any mounting lug from the plane formed by the three other lugs is 2 mm ($\frac{5}{64}$ ").
- ⑧ The Z points are reference points for the vertical position of the X and Y points.
The dimensions for the position of the X, Y and Z points also apply to the border line of the minimum useful screen area.
- ⑨ Mounting holes for the degaussing coils.
- ⑩ Panel contour.
- ⑪ Tolerance of the mounting lugs.
- ⑫ Tube length from the centre of the faceplate to the bottom of the base.
- ⑬ The outer limitation of the mounting lugs lies within these maximal dimensions.
- ⑭ Eccentricity to the inner contour of the glass panel max. 1,5 mm ($\frac{1}{16}$ ").
- ⑮ Limit of the glass panel by the steel reinforcement.

Colour Picture Tubes

A 66-120 X

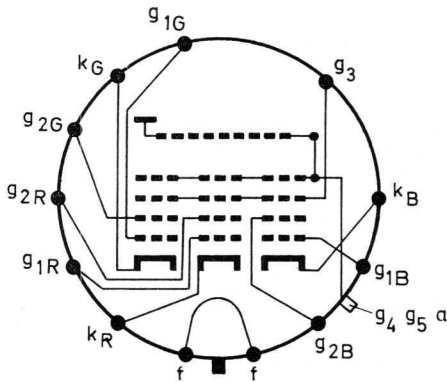

ITT-Picture Tube A 66-120 X is a rectangular colour picture tube with 90° deflection angle and 36,5 mm neck diameter.

The useful screen area of 2030 cm² (appr.) has nearly straight sides of 52 x 39 cm (appr.) with 3 x 4 aspect ratio. The filter-glass of the faceplate has a light transmission of 52 % (appr.).

The phosphor screen is composed of triangular dot groups – colour triplets – each consisting of a red-, green- and blue-emitting phosphor dot. The green- and blue-emitting phosphors are silver activated sulfide phosphors, the red emitting phosphor is composed of yttrium compounds activated with rare-earths.

The tube uses three electrostatically focused guns and operates on the shadow mask principle.

The gun axes are tilted slightly towards the tube axis to facilitate convergence to the shadow mask. Beam-convergence and deflection are provided magnetically.

Implosion protection by steel reinforcement. Admitted by Association of German Electrical Engineers, VDE.

1. Generalities

Bulb	All-Glass Type with Convex Rectangular Faceplate Filter-Glass	
Minimum Useful Screen Dimensions	Diagonal	618 mm
	Horizontal	518 mm
	Vertical	390 mm
	Aspect Ratio	3 x 4
	Area (approx.)	2030 cm ²
Deflection Angles	Diagonal	90°
	Horizontal	79°
	Vertical	62°
Neck Diameter	36,5 mm	
Weight	21 kg (appr.)	
Base	JEDEC B 12-244	
	14-20/1 DIN 44439 (Long Design)	
Implosion Protection	Steel-Jacket	
	Including Tube Mount	

2. Typical Operating Conditions ①

U_f ②	6,3 V
I_f	(approx.) 0,9 A
U_{g4g5a}	25 kV
U_{g3}	4,2 ... 5,0 kV
U_{g2} cutoff ③ ④ at $(-U_{g1}) = 105$ V	210 ... 495 V
$(-U_{g1})$ cutoff ④ at $-U_{g2} = 300$ V	70 ... 140 V

3. Maximum Ratings ⑧

U_{g4g5a} max ⑥	27,5 kV
U_{g4g5a} min	20 kV
I_{g4g5a} max ⑤	1,0 mA
U_{g3} max	6,0 kV
U_{g2} p max	1,0 kV
$(-U_{g1})$ p max	400 V
$(-U_{g1})$ max	200 V
U_{g1} max	0 V
U_{g1} p max	2 V
$U_{-f/k}$ max 1 ⑨ ⑩	410 V
$U_{-f/k}$ max 2 ⑨ ⑩	250 V
$U_{-f/k}$ p max ⑨	300 V
$U_{+f/k}$ p max ⑨	180 V
$U_{+f/k}$ max ⑨	135 V

4. Ratings for Circuit Design ⑦

I_{g3}	$\leq \pm 15 \mu\text{A}$
I_{g2}	$\leq \pm 5 \mu\text{A}$
I_{g1} ($-U_{g1} = 150$ V)	$\leq \pm 5 \mu\text{A}$

5. Capacitances

C_{g1}	approx. 7 pF
C_k	approx. 5 pF
C_{g3}	approx. 7 pF
$C_{g4g5a/m}$ max	2500 pF
$C_{g4g5a/m}$ min	2000 pF
$C_{g4g5a/m}$	approx. 500 pF

6. Optical Data

Faceplate:	Filter-Glass
Light Transmission	(appr.) 52 %

Screen:

Three separate phosphor dots – colour triplets – arranged in triangular groups and aluminized.

Spacing between centres of adjacent triplets nearest centre of screen 0,81 mm (approx.)

Colour Picture Tubes

A 66-120 X

Dimensional Drawings in mm

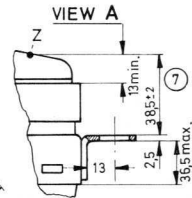
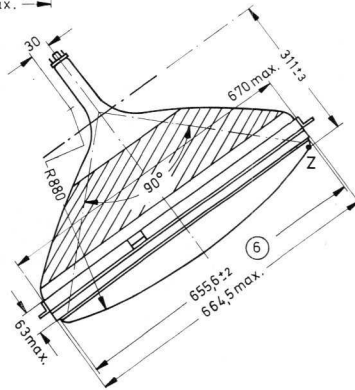
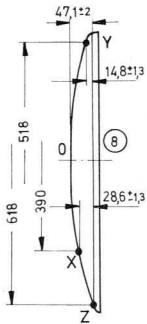
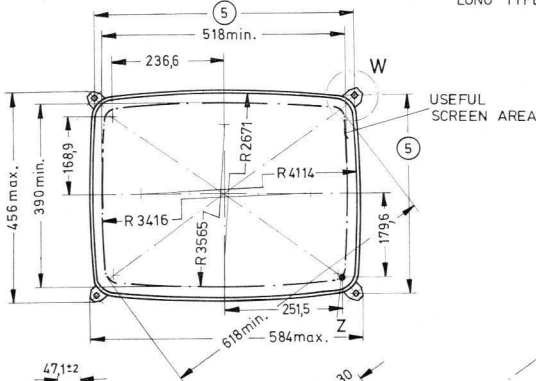
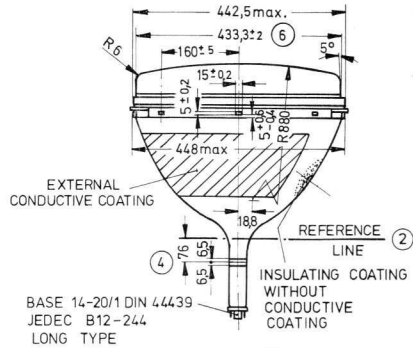
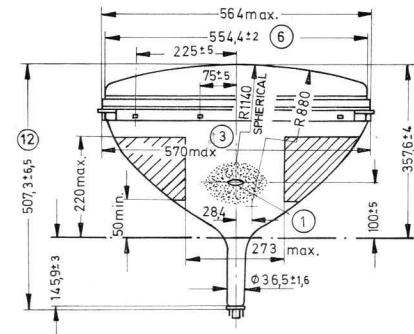

A66-120 X

O Notes see pages 68 and 69

Reference line gauge see page 66

Colour Picture Tubes

A 66-120 X

RELATIVE MOUNTING OF TYPICAL COMPONENTS

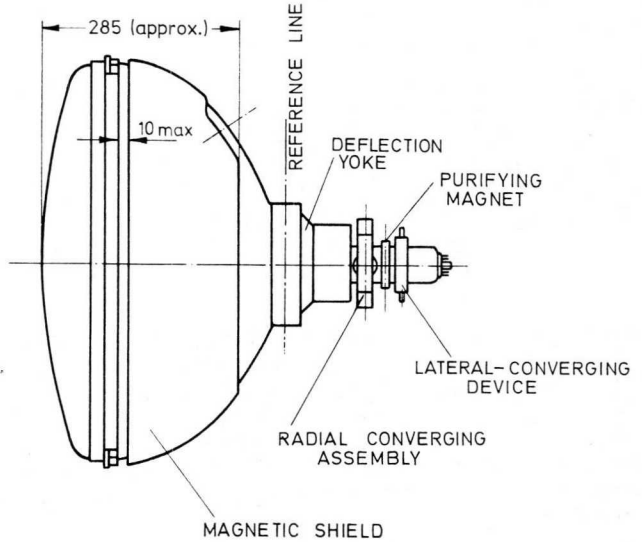

LOCATION OF RADIAL-CONVERGING POLE PIECES

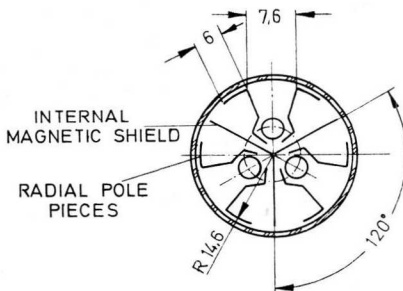

BOTTOM VIEW OF BASE

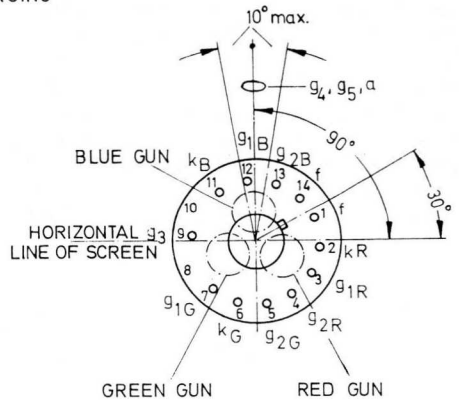

Colour Picture Tubes

A 66-140 X

A 66-410 X

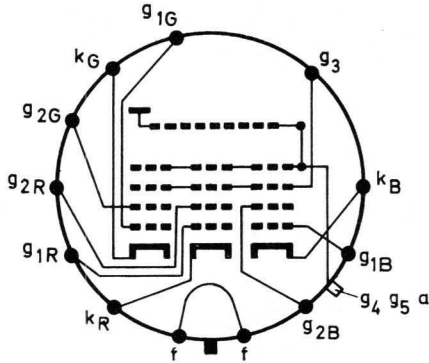

ITT-Picture Tube A 66-140 X (A 66-410 X) is a rectangular colour picture tube with 110° deflection angle and 36,5 mm neck diameter. The useful screen area of 2030 cm² (appr.) has nearly straight sides of 52 x 39 cm (appr.) with 3 x 4 aspect ratio. The filterglass of the faceplate has a light transmission of 52% (appr.).

The phosphor screen is composed of triangular dot groups – colour triplets – each consisting of a red-, green- and blue-emitting phosphor dot. The green- and blue-emitting phosphors are silver activated sulfide phosphors, the red emitting phosphor is composed of yttrium compounds activated with rare-earths.

The tube uses three electrostatically focused guns and operates on the shadow mask principle.

The gun axes are tilted slightly towards the tube axis to facilitate convergence to the shadow mask. Beam-convergence and deflection are provided magnetically.

Implosion protection by steel reinforcement. Admitted by Association of German Electrical Engineers, VDE.

1. Generalities

Bulb	All-Glass Type with Convex Rectangular Faceplate Filter-Glass	
Internal Magnetic Shield		
Minimum Useful	Diagonal	618 mm
Screen Dimensions	Horizontal	518 mm
	Vertical	390 mm
Aspect Ratio	3 x 4	
Area (approx.)	2030 cm ²	
Deflection Angles	Diagonal	110°
	Horizontal	97°
	Vertical	77°
Neck Diameter	36,5 mm	
Weight	20 kg (approx.)	
Base	JEDEC B 12-244	
	14-20/1 DIN 44439 (Long Design)	
Heating Time ⁽¹⁾	5s A 66-410 X (approx.)	
Implosion Protection	Steel Reinforcement	
	Including Mounting Lugs	

Colour Picture Tubes

A 66-140 X

A 66-410 X

2. Typical Operating Conditions ①

U_f ②	6,3 V
I_f A 66-140 X	(approx.) 0,820 A
I_f A 66-410 X	(approx.) 0,730 A
U_{g4g5a}	25 kV
U_{g3}	4,2 ... 5,0 kV
U_{g2} cutoff ③ ④	210 ... 495 V
at $(-U_{g1}) = 105$ V	
$(-U_{g1})$ cutoff ④	70 ... 140 V
at $-U_{g2} = 300$ V	

3. Maximum Ratings ⑧

U_{g4g5a} max ⑥	27,5 kV
U_{g4g5a} min	20 kV
I_{g4g5a} max ⑤	1,0 mA
U_{g3} max	6,0 kV
U_{g2} p max	1,0 kV
$(-U_{g1})$ p max	400 V
$(-U_{g1})$ max	200 V
U_{g1} max	0 V
U_{g1} p max	2 V
$U_{-f/k}$ max 1 ⑨ ⑩	410 V
$U_{-f/k}$ max 2 ⑨ ⑩	250 V
$U_{-f/k}$ p max ⑨	300 V
$U_{+f/k}$ p max ⑨	180 V
$U_{+f/k}$ max ⑨	135 V

4. Ratings for Circuit Design ⑦

I_{g3}	$\leq \pm 15 \mu\text{A}$
I_{g2}	$\leq \pm 5 \mu\text{A}$
I_{g1} ($-U_{g1} = 150$ V)	$\leq \pm 5 \mu\text{A}$

5. Capacitances

C_{g1}	approx.	7 pF
C_k	approx.	5 pF
C_{g3}	approx.	7 pF
$C_{g4g5a/m}$ max		2500 pF
$C_{g4g5a/m}$ min		2000 pF
$C_{g4g5a/m}$ '	approx.	500 pF

6. Optical Data

Faceplate:	Filter-Glass
Light Transmission	(appr.) 52 %

Screen:

Three separate phosphor dots — colour triplets — arranged in triangular groups and aluminized.

Spacing between centres of adjacent triplets nearest centre of screen 0,81 mm (appr.)

Colour Picture Tubes

A 66-140 X

A 66-410 X

Dimensional Drawings in mm

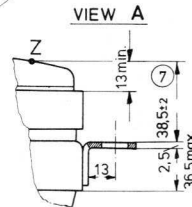
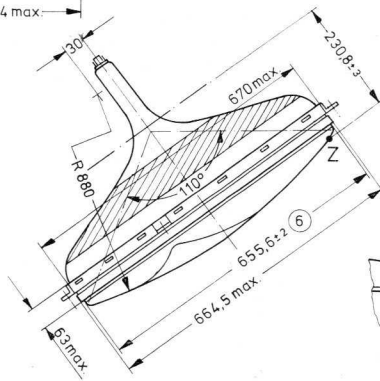
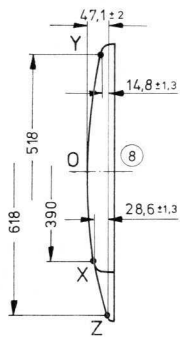
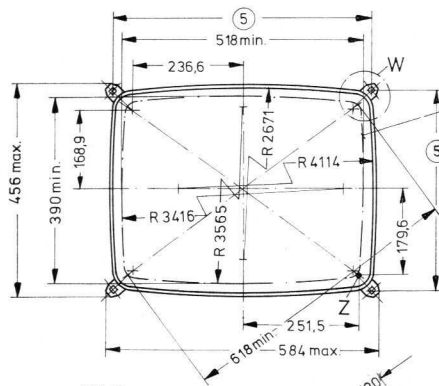
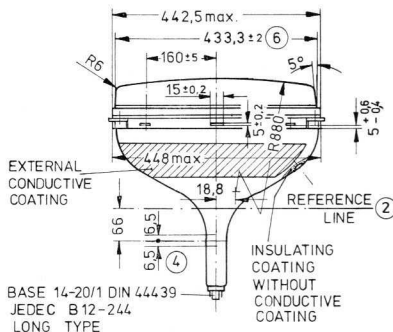
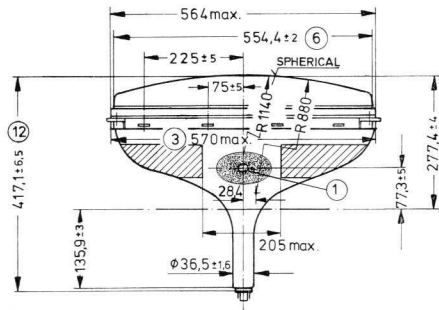

A66-140 X

O Notes see pages 68 and 69

Reference line gauge see page 66

Colour Picture Tubes

A 66-140 X

A 66-410 X

RELATIVE MOUNTING OF TYPICAL COMPONENTS

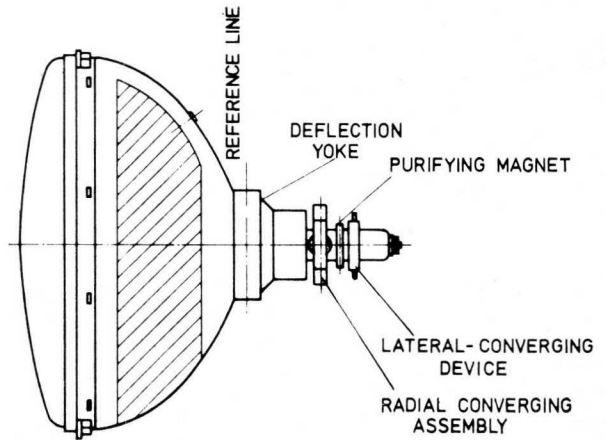

LOCATION OF RADIAL-CONVERGING
POLE PIECES

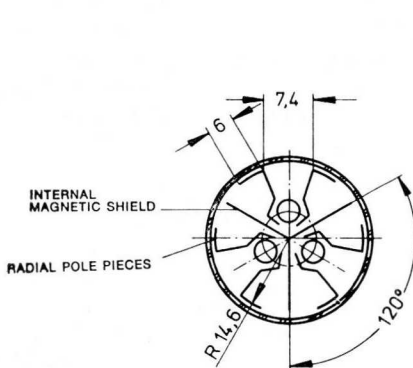

BOTTOM VIEW OF BASE

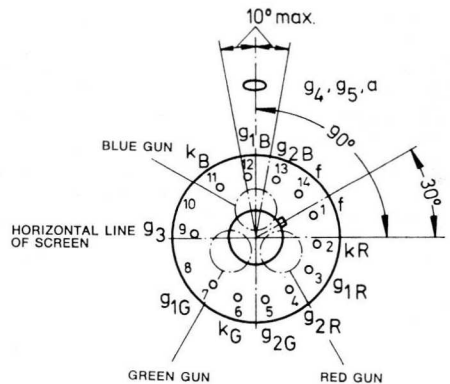

Colour Picture Tubes

A 67-150 X

A 67-510 X

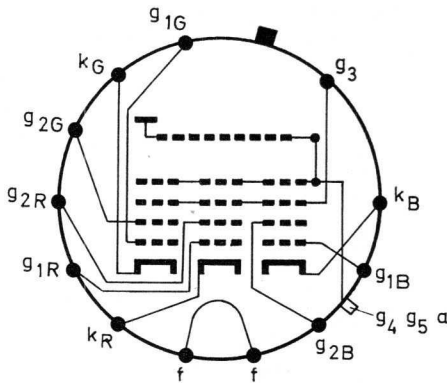

ITT-Picture Tube A67-150X (A67-510X) is a rectangular colour picture tube with 110° deflection angle and 29 mm neck diameter. The useful screen area of 2100 cm^2 (appr.) has nearly straight sides of $53 \times 40 \text{ cm}$ (appr.) with 3×4 aspect ratio. The filter-glass of the faceplate has a light transmission of $49,5\%$ (appr.).

The phosphor screen is composed of triangular dot groups – colour triplets – each consisting of a red-, green- and blue-emitting phosphor dot. The green- and blue-emitting phosphors are silver activated sulfide phosphors, the red emitting phosphor is composed of yttrium compounds activated with rare-earths.

The tube uses three electrostatically focused guns and operates on the shadow mask principle.

The gun axes are tilted slightly towards the tube axis to facilitate convergence to the shadow mask. Beam-convergence and deflection are provided magnetically.

Implosion protection by steel reinforcement. Admitted by Association of German Electrical Engineers, VDE

1. Mechanical Data

Bulb	All-Glass Type with Convex Rectangular Faceplate Filter-Glass	
Internal Magnetic Shield		
Minimum Useful	Diagonal	626 mm
Screen Dimensions	Horizontal	528 mm
	Vertical	396 mm
	Aspect Ratio	3 x 4
	Area (approx.)	2100 cm^2
Deflection Angles	Diagonal	110°
	Horizontal	97°
	Vertical	77°
Neck Diameter	29 mm	
Overall Length	$432 \pm 6 \text{ mm}$	
Weight	20 kg (appr.)	
Base	JEDEC B 12-260	
Heating Time (11)	5_g (approx.) A67-510X	
Implosion Protection	Steel-Jacket Including Tube Mount	

Colour Picture Tubes

A 67-150 X

A 67-510 X

2. Typical Operating Conditions ①

U_f ②	6,3 V
I_f A 67-150 X	(approx.) 0,780 A
I_f A 67-510 X	(approx.) 0,730 A
U_{g4g5a}	25 kV
U_{g3}	4,2 ... 5,0 kV
U_{g2} cutoff ③ ④	160 ... 445 V
at $(-U_{g1}) = 105$ V	
$(-U_{g1})$ cutoff ④	76 ... 162 V
at $-U_{g2} = 300$ V	

3. Maximum Ratings ⑧

U_{g4g5a} max ⑥	27,5 kV
U_{g4g5a} min	20 kV
I_{g4g5a} max ⑤	1,0 mA
U_{g3} max	6,0 kV
U_{g2} p max	1,0 kV
$(-U_{g1})$ p max	400 V
$(-U_{g1})$ max	200 V
U_{g1} max	0 V
U_{g1} p max	2 V
$U_{-f/k}$ max 1 ⑨ ⑩	450 V
$U_{-f/k}$ max 2 ⑨ ⑩	200 V
$U_{-f/k}$ p max ⑨	200 V
$U_{+f/k}$ p max ⑨	200 V
$U_{+f/k}$ max ⑨	0 V

4. Ratings for Circuit Design ⑦

I_{g3}	$\leq \pm 15 \mu\text{A}$
I_{g2}	$\leq \pm 5 \mu\text{A}$
I_{g1} ($-U_{g1} = 150$ V)	$\leq \pm 5 \mu\text{A}$

5. Capacitances

C_{g1}	approx. 3,8 pF
C_k	approx. 6,3 pF
C_{g3}	approx. 2,6 pF
$C_{g4g5a/m}$ max	2500 pF
$C_{g4g5a/m}$ min	2000 pF
$C_{g4g5a/m}$ †	approx. 450 pF

6. Optical Data

Faceplate:	Filter-Glass
Light Transmission	(appr.) 49,5%

Screen:

Three separate phosphor dots – colour triplets – arranged in triangular groups and aluminized.

Spacing between centres of adjacent triplets nearest centre of screen 0,66 mm (appr.).

Colour Picture Tubes

A 67-150 X

A 67-510 X

Dimensional Drawings in mm

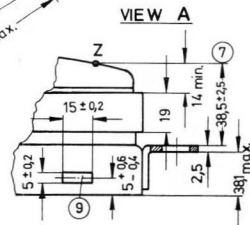
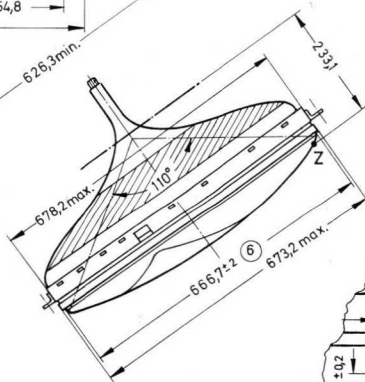
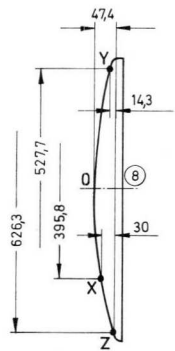
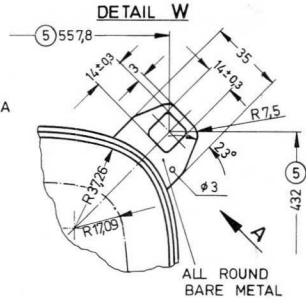
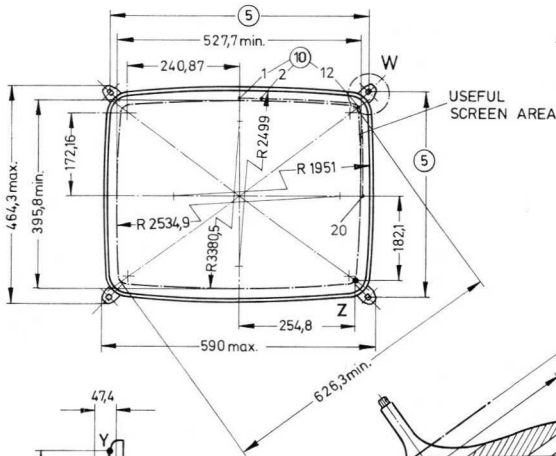
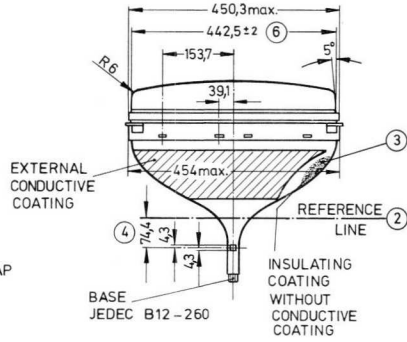
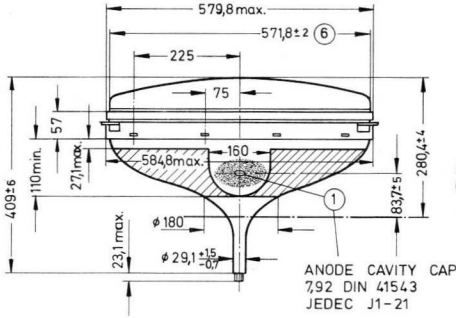

A 67-150 X

Notes see pages 68 and 69

Reference line gauge see page 66

Colour Picutre Tubes

A 67-150 X

A 67-510 X

RELATIVE MOUNTING OF TYPICAL COMPONENTS

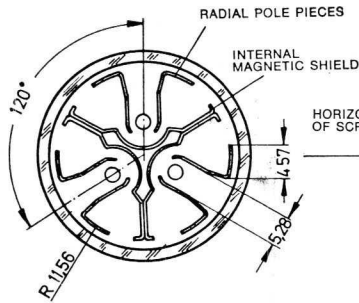
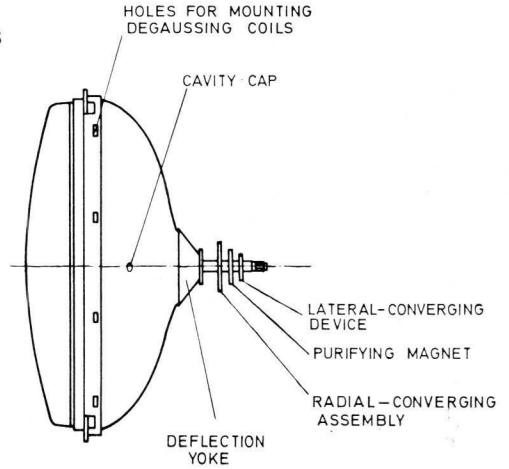

LOCATION OF RADIAL-CONVERGING POLE PIECES

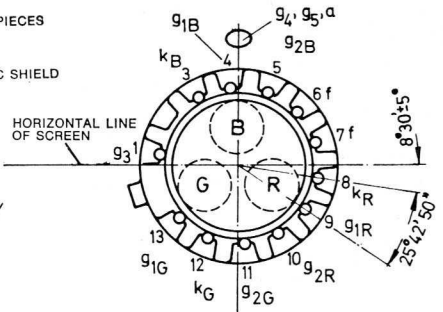

BOTTOM VIEW OF BASE

Colour Picture Tubes

A 55-14 X

For Replacement

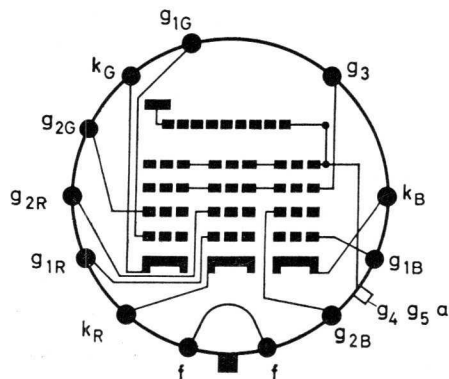

ITT-Picture Tube A 55-14 X is a rectangular colour picture tube with 90° deflection angle and 36,5 mm neck diameter.

The useful screen area of 1465 cm^2 (appr.) has nearly straight sides of $44 \times 35 \text{ cm}$ (appr.) with 3×4 aspect ratio. The filter-glass of the faceplate has a light transmission of 52% (appr.).

The phosphor screen is composed of triangular dot groups – colour triplets – each consisting of a red-, green- and blue-emitting phosphor dot. The green- and blue-emitting phosphors are silver activated sulfide phosphors, the red emitting phosphor is composed of yttrium compounds activated with rare-earths.

The gun axes are tilted slightly towards the ed guns and operates on the shadow mask principle.

The gun axes are tilted slightly toward the tube axis to facilitate convergence to the shadow mask. Beam-convergence and deflection are provided magnetically.

Implosion protection by steel reinforcement.

Admitted by Association of German Electrical Engineers, VDE

1. Generalities

Bulb	All-Glass Type with Convex Rectangular Faceplate Filter-Glass	
Minimum Useful Screen Dimensions	Diagonal	514 mm
	Horizontal	443 mm
	Vertical	346 mm
Aspect Ratio	3 x 4	
	Area (approx.)	1465 cm^2
Deflection Angles	Diagonal	90°
	Horizontal	79°
	Vertical	63°
Neck Diameter	36,5 mm	
Overall Length	$483 \pm 9,5 \text{ mm}$	
Weight	16 kg (appr.)	
Base	JEDEC B 12-244	
	14-20/1 DIN 44439	
Implosion Protection	Steel-Jacket including Tube Mount	

Colour Picture Tubes

A 55—14 X

For Replacement

2. Typical Operating Conditions ①

U_f ②	6,3 V
I_f	(approx.) 0,9 A
U_{g4g5a}	25 kV
U_{g3}	4,2 ... 5,0 kV
U_{g2} cutoff ③ ④	285 ... 685 V
at $(-U_{g1}) = 150$ V	
$(-U_{g1})$ cutoff ④	95 ... 190 V
at $U_{g2} = 400$ V	

3. Maximum Ratings ⑧

U_{g4g5a} max ⑥	27,5 kV
U_{g4g5a} min	20 kV
I_{g4g5a} max ⑤	1,0 mA
U_{g3} max	6,0 kV
U_{g2} p max	1,0 kV
$(-U_{g1})$ p max	400 V
$(-U_{g1})$ max	200 V
U_{g1} max	0 V
U_{g1} p max	2 V
$U_{-f/k}$ max 1 ⑨ ⑩	410 V
$U_{-f/k}$ max 2 ⑨ ⑩	250 V
$U_{-f/k}$ p max ⑨	300 V
$U_{+f/k}$ p max ⑨	180 V
$U_{+f/k}$ max ⑨	135 V

4. Ratings for Circuit Design ⑦

I_{g3}	$\leq -45 \dots + 15 \mu\text{A}$
I_{g2}	$\leq \pm 5 \mu\text{A}$
I_{g1} ($-U_{g1}) = 150$ V	$\leq \pm 5 \mu\text{A}$

5. Capacitances

C_{g1}	(approx.) 6 pF
C_k	(approx.) 5 pF
C_{g3}	(approx.) 6,5 pF
$C_{g4g5a/m}$ max	2500 pF
$C_{g4g5a/m}$ min	2000 pF
$C_{g4g5a/m}$ '	(approx.) 280 pF

6. Optical Data

Faceplate:	Filter-Glass
Light Transmission	(appr.) 52%

Screen:

Three separate phosphor dots – colour-triplets – arranged in triangular groups and aluminized.

Spacing between centres of adjacent triplets nearest centre of screen 0.64 mm (approx.)

Colour Picture Tubes

A 55-14 X

For Replacement

Dimensional Drawings in mm

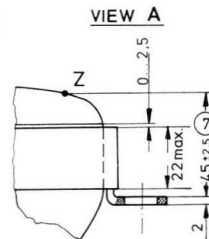
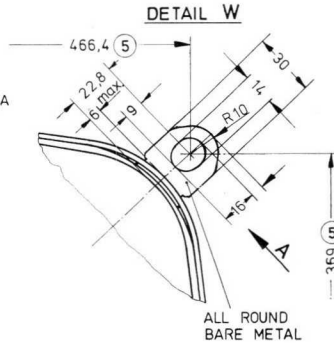
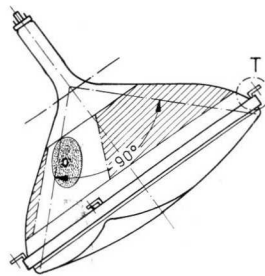
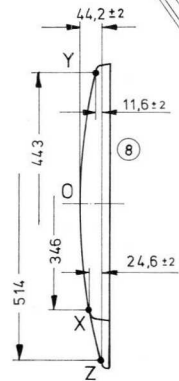
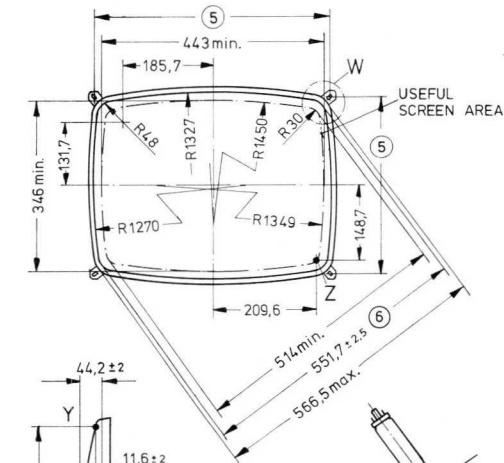
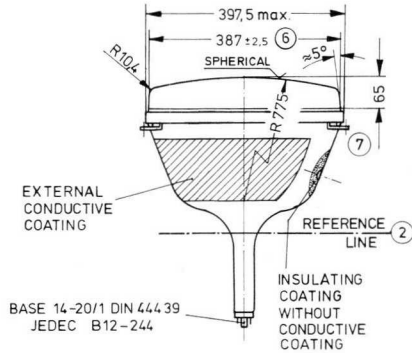
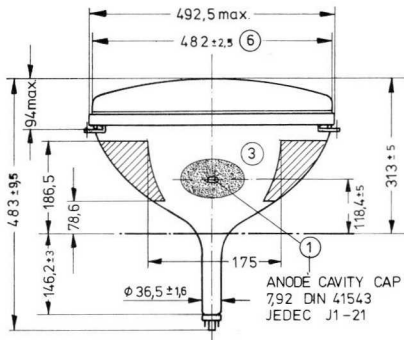

A 55-14 X

O Notes see pages 68 and 69

Reference line gauge see page 66

Colour Picture Tubes

A 55—14 X

For Replacement

RELATIVE MOUNTING OF TYPICAL COMPONENTS

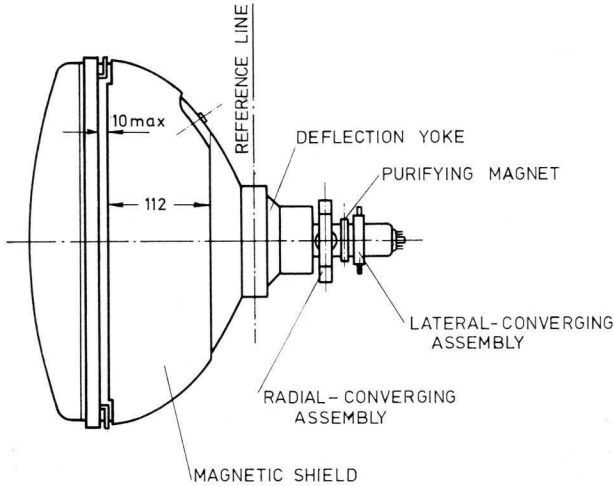

LOCATION OF RADIAL-CONVERGING POLE PIECES

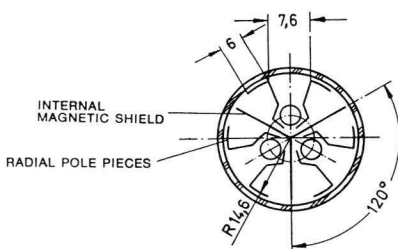

BOTTOM VIEW OF BASE

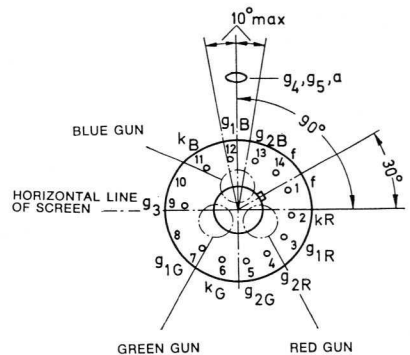

Colour Picture Tubes

A 56--120 X

For Replacement

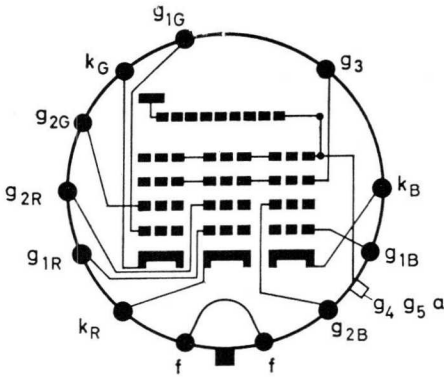

ITT-Picture Tube A 56--120 X is a rectangular colour picture tube with 90° deflection angle and 36,5 mm neck diameter.

The useful screen area of 1465 cm² (appr.) has nearly straight sides of 44 x 35 cm (appr.) with 3 x 4 aspect ratio. The filter-glass of the faceplate has a light transmission of 52% (appr.).

The phosphor screen is composed of triangular dot groups — colour triplets — each consisting of a red-, green- and blue-emitting phosphor dot. The green- and blue-emitting phosphors are silver activated sulfide phosphors, the red emitting phosphor is composed of yttrium compounds activated with rare-earths.

The tube uses three electrostatically focused guns and operates on the shadow mask principle.

The gun axes are tilted slightly towards the tube axis to facilitate convergence to the shadow mask. Beam-convergence and deflection are provided magnetically.

Implosion protection by steel reinforcement. Admitted by Association of German Electrical Engineers, VDE.

1. Mechanical Data

Bulb	All-Glass Type with Convex Rectangular Faceplate Filter-Glass	
Minimum Useful Screen Dimensions	Diagonal	533 mm
	Horizontal	447 mm
	Vertical	337 mm
	Aspect Ratio	3 x 4
	Area (approx.)	1465 cm ²
Deflection Angles	Diagonal	90°
	Horizontal	79°
	Vertical	63°
Neck Diameter	36,5 mm	
Overall Length	472 ± 9,5 mm	
Weight	15 kg (appr.)	
Base	JEDEC B 12-244	
	14-20/1 DIN 44439	
Implosion Protection	Steel-Jacket Including Tube Mount	

Colour Picture Tubes

A 56–120 X

For Replacement

2. Typical Operating Conditions ①

U_f ②	6,3 V
I_f	(approx.) 0,9 A
U_{g4g5a}	25 kV
U_{g3}	4,2 ... 5,0 kV
U_{g2} cutoff ③ ④	210 ... 495 V
at $(-U_{g1}) = 105$ V	
$(-U_{g1})$ cutoff ④	70 ... 140 V
at $-U_{g2} = 300$ V	

3. Maximum Ratings ⑧

U_{g4g5a} max ⑥	27,5 kV
U_{g4g5a} min	20 kV
I_{g4g5a} max ⑤	1,0 mA
U_{g3} max	6,0 kV
U_{g2} p max	1,0 kV
$(-U_{g1})$ p max	400 V
$(-U_{g1})$ max	200 V
U_{g1} max	0 V
U_{g1} p max	2 V
$U_{-f/k}$ max 1 ⑨ ⑩	410 V
$U_{-f/k}$ max 2 ⑨ ⑩	250 V
$U_{-f/k}$ p max ⑨	300 V
$U_{+f/k}$ p max ⑨	180 V
$U_{+f/k}$ max ⑨	135 V

4. Ratings for Circuit Design ⑦

I_{g3}	$\leq \pm 15 \mu\text{A}$
I_{g2}	$\leq \pm 5 \mu\text{A}$
I_{g1} ($-U_{g1} = 150$ V)	$\leq \pm 5 \mu\text{A}$

5. Capacitances

C_{g1}	(approx.) 6 pF
C_k	(approx.) 5 pF
C_{g3}	(approx.) 6,5 pF
$C_{g4g5a/m}$ max	2300 pF
$C_{g4g5a/m}$ min	1700 pF
$C_{g4g5a/m'}$	(approx.) 280 pF

6. Optical Data

Faceplate:	Filter-Glass
Light Transmission	(appr.) 52%

Screen:

Three separate phosphor dots – colour triplets – arranged in triangular groups and aluminized.

Spacing between centres of adjacent triplets nearest centre of screen 0,64 mm (appr.).

Colour Picture Tubes

A 56-120 X

For Replacement

Dimensional Drawings in mm

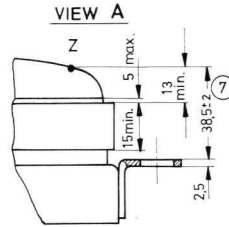
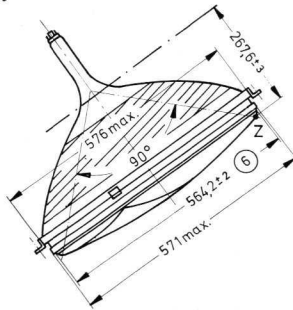
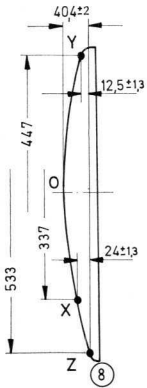
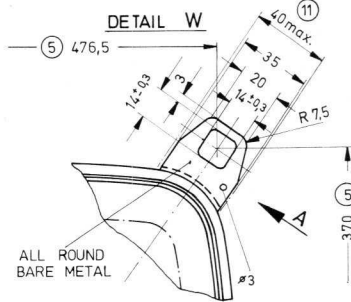
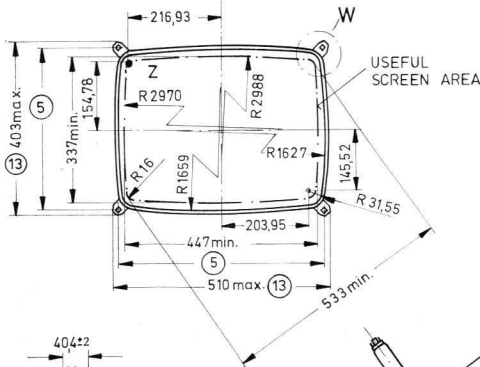
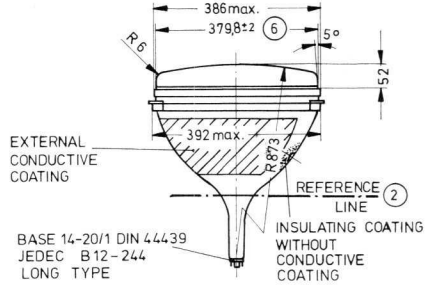
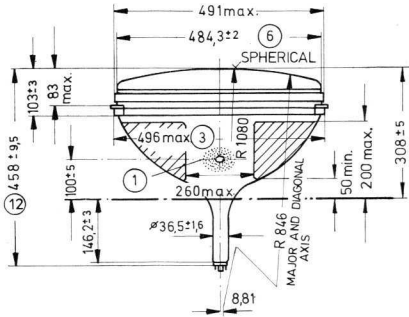

A 56-120 X

○ Notes see pages 68 and 69

Reference line gauge see page 66

Colour Picture Tubes

A 56-120 X

For Replacement

RELATIVE MOUNTING OF TYPICAL COMPONENTS

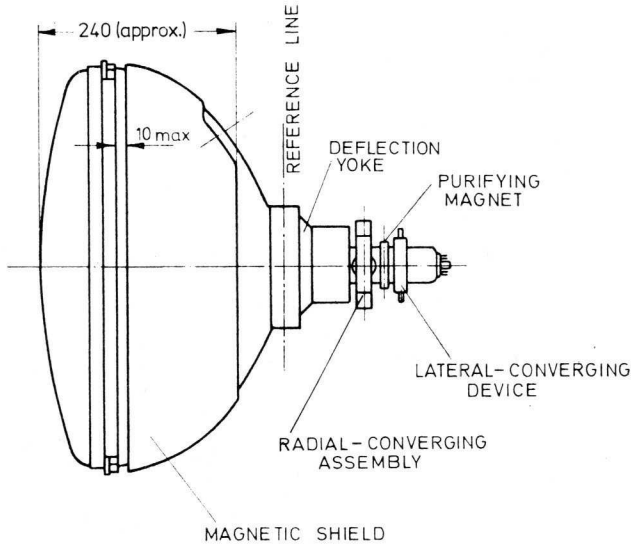

LOCATION OF RADIAL-CONVERGING POLE PIECES

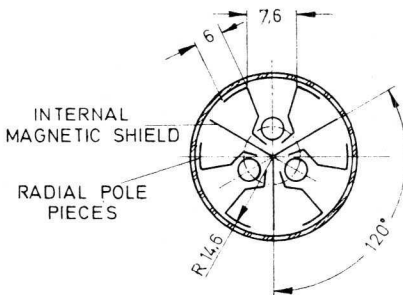

BOTTOM VIEW OF BASE

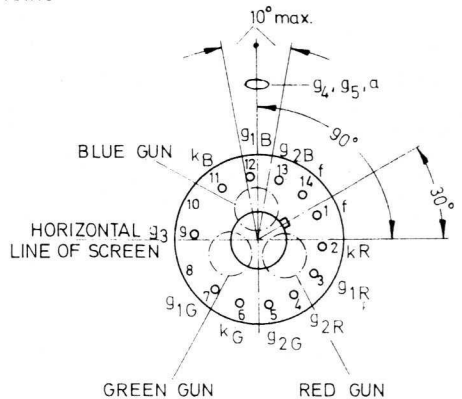

Colour Picture Tubes

A 63-11 X and A 63-200 X

For Replacement

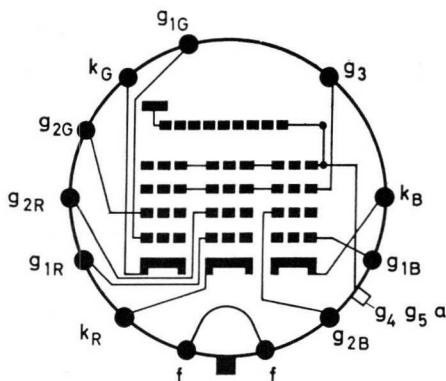

ITT-Picture Tube A 63-11 X (A 63-200 X) is a rectangular colour picture tube with 89° deflection angle and 36,5 mm neck diameter.

The useful screen area of 2000 cm² (appr.) has nearly straight sides of 50 x 40 cm (appr.). The filter-glass of the faceplate has a light transmission of 52% (appr.).

The phosphor screen is composed of triangular dot groups – colour triplets – each consisting of a red-, green- and blue-emitting phosphor dot. The green- and blue-emitting phosphors are silver activated sulfide phosphors, the red emitting phosphor is composed of yttrium compounds activated with rare-earths.

The tube uses three electrostatically focused guns and operates on the shadow mask principle.

The gun axes are tilted slightly toward the tube axis to facilitate convergence to the shadow mask. Beam-convergence and deflection are provided magnetically.

Implosion protection by steel reinforcement. Admitted by Association of German Electrical Engineers, VDE.

1. Mechanical Data

Bulb	All-Glass Type with Convex Rectangular Faceplate Filter-Glass	
Minimum Useful Screen Dimensions	Diagonal	584 mm
	Horizontal	504 mm
	Vertical	396 mm
	Area (appr.)	2000 cm ²
Deflection Angles	Diagonal	89°
	Horizontal	78°
	Vertical	63°
Neck Diameter	36,5 mm	
Overall Length	526 ± 9,5 mm	
Weight	19 kg (appr.)	
Base	JEDEC B 12-244	
	14-20/1 DIN 44439	
Implosion Protection	Steel-Jacket Including Tube Mount	

Colour Picture Tubes

A 63—11 X and A 63—200 X

For Replacement

2. Typical Operating Conditions ①

U_f ②	6,3 V
I_f	(approx.) 0,9 A
U_{g4g5a}	25 kV
U_{g3}	4,2 ... 5,0 kV
U_{g2} cutoff ③ ④ (at $(-U_{g1}) = 150$ V)	285 ... 685 V
$(-U_{g1})$ cutoff ④ (at $U_{g2} = 400$ V)	95 ... 190 V

3. Maximum Ratings ⑧

U_{g4g5a} max ⑥	27,5 kV
U_{g4g5a} min	20 kV
I_{g4g5a} max ⑤	1,0 mA
U_{g3} max	6,0 kV
U_{g2} p max	1,0 kV
$(-U_{g1})$ p max	400 V
$(-U_{g1})$ max	200 V
U_{g1} max	0 V
U_{g1} p max	2 V
$U_{-f/k}$ max 1 ⑨ ⑩	410 V
$U_{-f/k}$ max 2 ⑨ ⑩	250 V
$U_{-f/k}$ p max ⑨	300 V
$U_{+f/k}$ p max ⑨	180 V
$U_{+f/k}$ max ⑨	135 V

4. Ratings for Circuit Design ⑦

I_{g3}	$\leq -45 \dots + 15 \mu\text{A}$
I_{g2}	$\leq \pm 5 \mu\text{A}$
I_{g1} ($-U_{g1} = 150$ V)	$\leq \pm 5 \mu\text{A}$

5. Capacitances

C_{g1}	(approx.) 6 pF
C_k	(approx.) 5 pF
C_{g3}	(approx.) 6,5 pF
$C_{g4g5a/m}$ max	3000 pF
$C_{g4g5a/m}$ min	2000 pF
$C_{g4g5a/m'}$	A 63—11 X (approx.) 400 pF
$C_{g4g5a/m'}$	A 63—200 X (approx.) 280 pF

6. Optical Data

Faceplate:	Filter-Glass
Light Transmission	(appr.) 52%

Screen:

Three separate phosphor dots — colour triplets — arranged in triangular groups and aluminized.

Spacing between centres of adjacent triplets nearest centre of screen 0,74 mm (appr.).

Colour Picture Tubes

A 63-11 X

For Replacement

Dimensional Drawings in mm

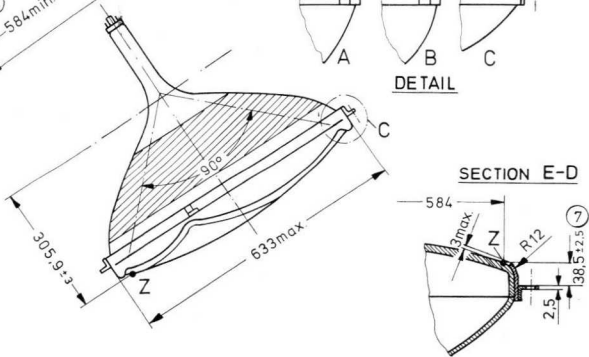
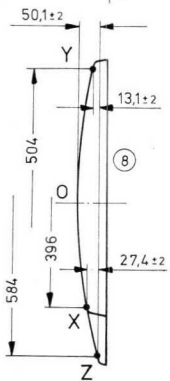
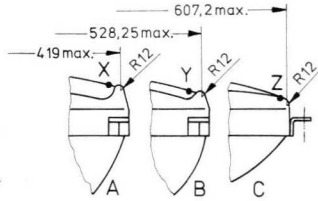
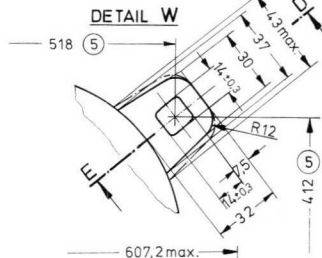
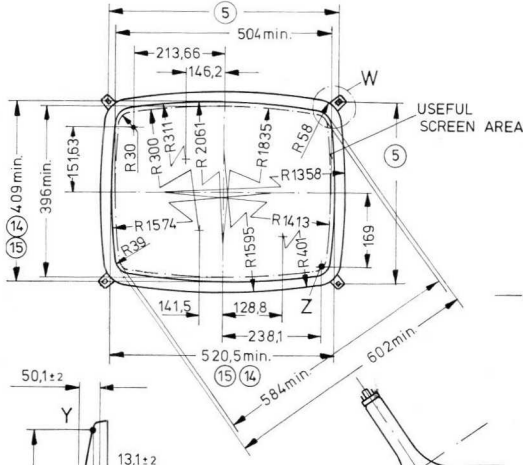
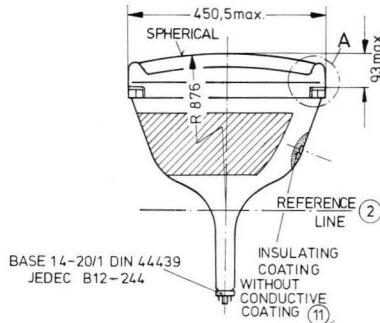
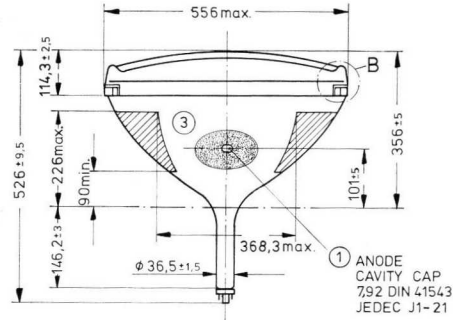

A 63-11 X

Notes see pages 68 and 69

Reference line gauge see page 66

Colour Picture Tubes

A 63-11 X

For Replacement

RELATIVE MOUNTING OF TYPICAL COMPONENTS

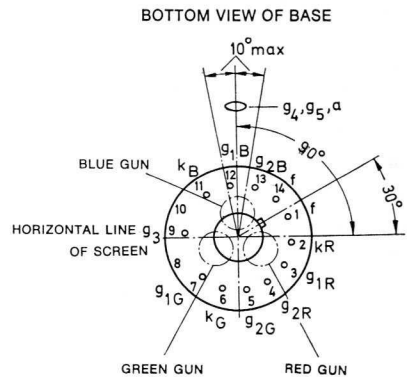
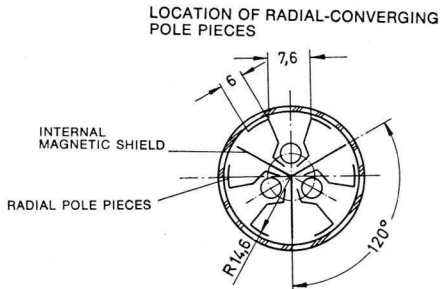
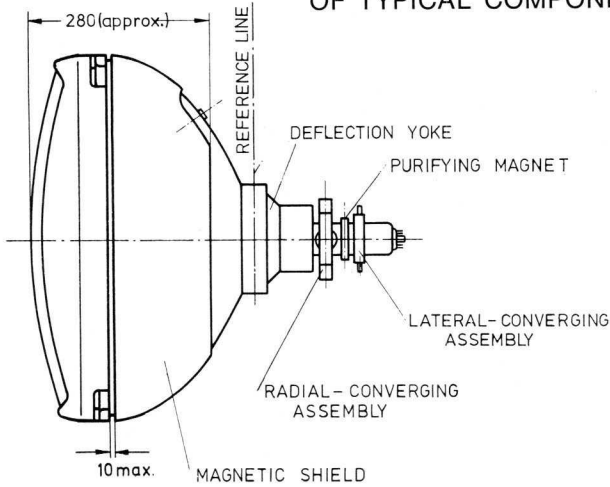

Colour Picture Tubes

A 63-200 X

For Replacement

Dimensional Drawings in mm

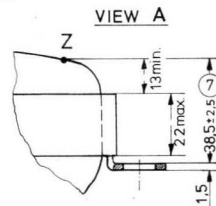
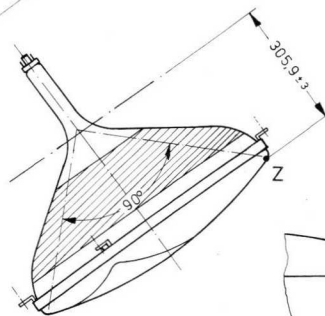
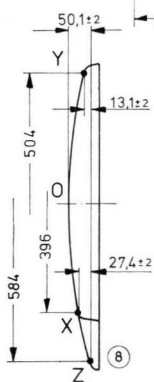
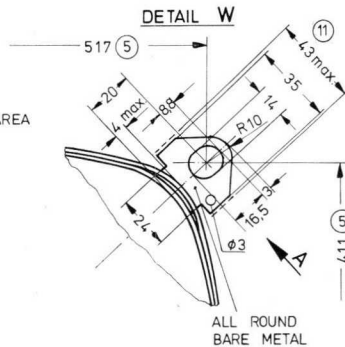
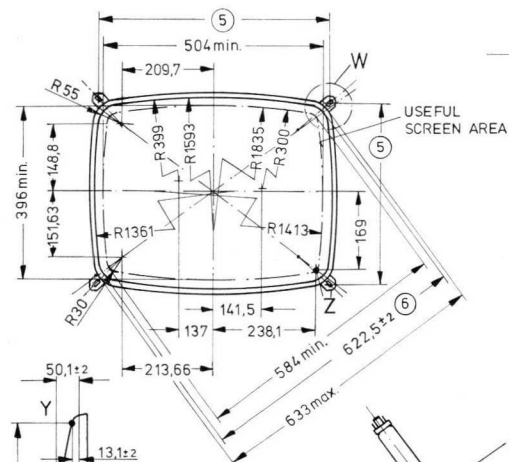
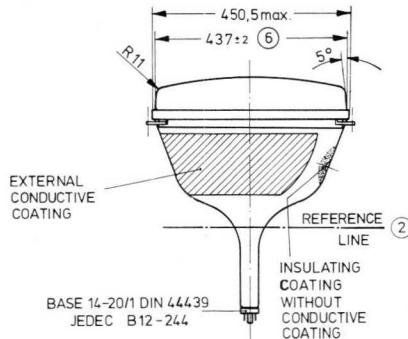
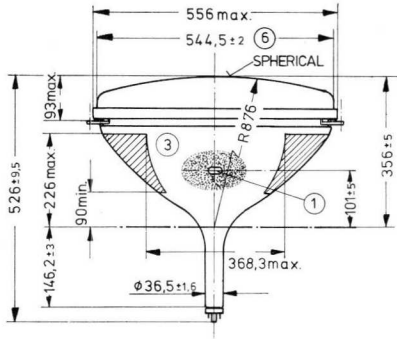

A63-200 X

O Notes see pages 68 and 69

Reference line gauge see page 66

Colour Picture Tubes

A 63-200 X

For Replacement

RELATIVE MOUNTING OF TYPICAL COMPONENTS

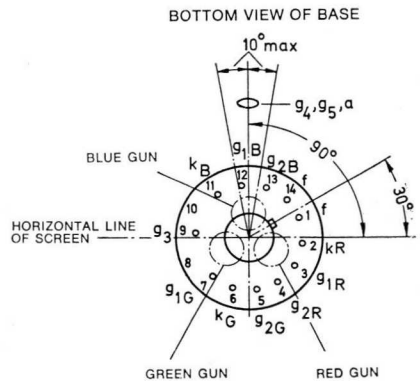
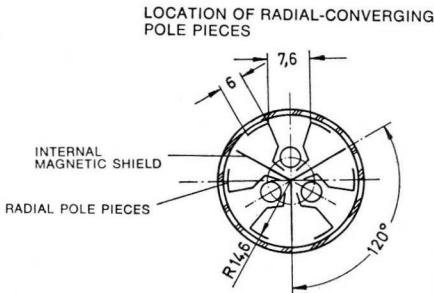
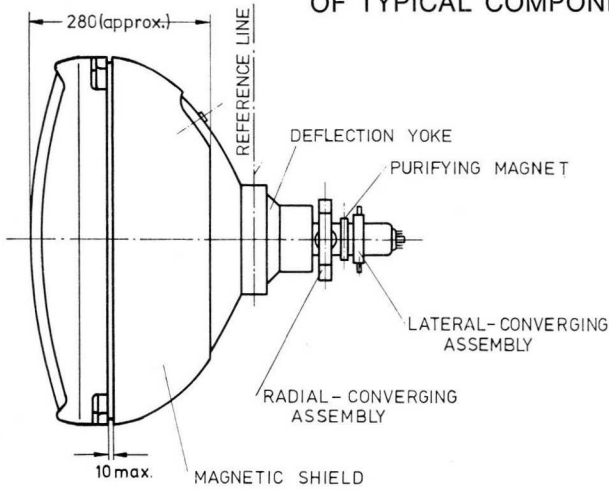

Delivery Programme

Rectifiers

Selenium Rectifiers
Silicon Rectifiers

Capacitors

Metallised Paper Capacitors MP
Polystyrene Foil Capacitors KS
Metallised Polyester Capacitors PMT
Metallised Polycarbonate Capacitors PMC
Tantalum Electrolytic Capacitors
Aluminium Electrolytic Capacitors
Ceramic Capacitors

Spark Suppressors

Resistors

Fixed and Variable Resistors

Non-linear Resistors

Thermistors and Varistors

Moduls

Quartz Crystals and Filters

Selenium Charge Carriers

Relays

Dry Reed Contacts and Reed Relays
Unsealed Relays

Digital Counters

Switches and Push Buttons

Rotary Switches
and Knob Detent Mechanisms
Push Button and Slider Switches

ISEP® (ITT Standard Equipment Practice)

Connectors, Sub-Racks,
Equipment Cases and Cabinets
Printed Circuit Boards

Dunkermotoren - Miniature Precision Motors

D.C. Motors
Single Phase and Three Phase A.C. Motors
Tachogenerators and Gears

Dunkermotoren - Drives for Venetian Blinds and Roll Shutters

Motors and Blowers

A.C. Motors
Gear Motors
Transverse Flow and Radial Blowers
Synchros and Tachometer Generators

Ringling and Signalling Machines

Infinitely Variable Speed Drives

Loudspeakers and HiFi Sound Sources

Miniature and Standard Loudspeakers
HiFi Loudspeakers
Extension Loudspeakers
HiFi Sound Sources
HiFi Assembly Kits
and Cabinet Assembly Kits

Tubes and Deflection Means

Radio and TV Tubes
Black/White and Colour Picture Tubes
Special Tubes and Microwave Devices
Deflection Means
for Black/White and Colour TV Sets

Semiconductor Components

Units for Electronic Control Technique

The components described in this data book represent only a small part of the wide range of electronic and electro-mechanical components manufactured and sold on ITT Components Group Europe.

For technical details as well as for terms of delivery concerning the above listed components please write to the following address:

ITT Components Group Europe

Standard Elektrik Lorenz AG
Components Group
Publicity Department
D-8500 Nürnberg
P.O. Box 2340 · Platenstraße 66
Telephone (09 11) 4 21-1 · Telex 6 22 211-12

These components are available from:

or directly from:

ITT Components Group Europe

Standard Elektrik Lorenz AG
Unternehmensgruppe Bauelemente
D-7300 Esslingen
P. O. Box 807 · Fritz-Müller-Strasse 112
Telephone (07 11) 35 14-1 · Telex 7 256 545