

TA-AX5

AEP Model
UK Model



INTEGRATED STEREO AMPLIFIER

SPECIFICATION

General System	Preamplifier section : low-noise NF type equalizer amp.; NF type tone control Power amplifier section : pure-complementary SEPP dc power amplifier with all stages direct coupled Power supply section : pulse power supply circuitry	Amplifier section Continuous RMS power output (Less than 0.005% THD, both channels driven simultaneously) At 20 Hz - 20 kHz 65 + 65 watts (8 ohms) According to DIN 45500 65 + 65 watts (8 ohms)
Power requirements	AEP model: 220 V ac, 50/60 Hz UK model: 240 V ac, 50/60 Hz	Power bandwidth (IHF) 5 Hz - 45 kHz Dynamic headroom 1.2 dB* Harmonic distortion Less than 0.005% at rated output Intermodulation (IM) distortion (60 Hz : 7 kHz = 4 : 1) Less than 0.005% at rated output
Power consumption	AEP model: 120 watts UK model: 350 watts	Frequency response PHONO : RIAA equalization curve ± 0.2 dB TUNER AUX TAPE 1,2) 5 Hz - 70 kHz ± 0 dB
Dimensions	Approx. 430 x 80 x 325 mm (w/h/d) (17 x 3 ¹ / ₄ x 13 inches) including projecting parts and controls	Residual noise Less than 90 μ V (8 ohms, network A) Damping factor 50 (8 ohms, 1 kHz)
Weight	Approx. 5 kg (11 lb 4 oz) net Approx. 5.8 kg (12 lb 13 oz) in shipping carton	

- Continued on page 2 -

WARNING!!

AN ISOLATION TRANSFORMER SHOULD BE USED DURING ANY SERVICE TO AVOID POSSIBLE SHOCK HAZARD, BECAUSE OF LIVE CHASSIS. THE CHASSIS OF THIS RECEIVER IS DIRECTLY CONNECTED TO THE AC POWER LINE.

SAFETY-RELATED COMPONENT WARNING!!

COMPONENTS IDENTIFIED BY SHADING AND MARK  ON THE SCHEMATIC DIAGRAMS, EXPLODED VIEWS AND IN THE PARTS LIST ARE CRITICAL TO SAFE OPERATION. REPLACE THESE COMPONENTS WITH SONY PARTS WHOSE PART NUMBERS APPEAR AS SHOWN IN THIS MANUAL OR IN SUPPLEMENTS PUBLISHED BY SONY.

SONY[®]

SERVICE MANUAL



Inputs

	Sensitivity	Impedance	Maximum input capability (1 kHz)	S/N (weighting network, input level)
MM	2.5 mV	50 k Ω	150 mV	90 dB 82 dB* (A, 2.5 mV)
PHONO				
MC	0.17 mV	100 Ω	10 mV	72 dB 68 dB* (A, 0.17 mV)
TUNER AUX TAPE 1, 2	150 mV	50 k Ω	—	104 dB 81 dB* (A, 150 mV)

* '78 IHF

Measured with rated output power into 8-ohm loads (both channels driven simultaneously) at 1 kHz

Outputs

REC OUT 1, 2
Voltage 150 mV
Impedance 4.7 kilohms

SPEAKER A, B
Accepts speakers of 8 - 16 ohms.

HEADPHONES
Accepts low and high impedance headphones.

Tone controls

BASS
 ± 10 dB at 50 Hz (turnover frequency 250 Hz)
 ± 10 dB at 100 Hz (turnover frequency 500 Hz)

TREBLE
 ± 10 dB at 25 kHz (turnover frequency 3 kHz)
 ± 10 dB at 50 kHz (turnover frequency 6 kHz)

Subsonic filter

6 dB/octave attenuation below 15 Hz

High filter

6 dB/octave attenuation above 9 kHz

Muting

-20 dB

MODEL IDENTIFICATION

— Specification Label —

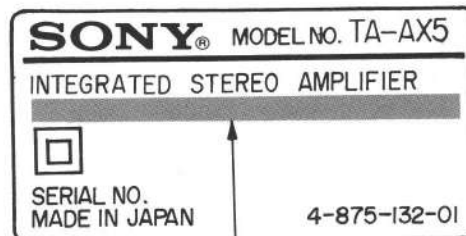

AEP model : AC 220V ~ 50/60Hz 120W
UK model : AC 240V ~ 50/60Hz 350W

SECTION 1
OUTLINE

1-1. BLOCK DIAGRAM

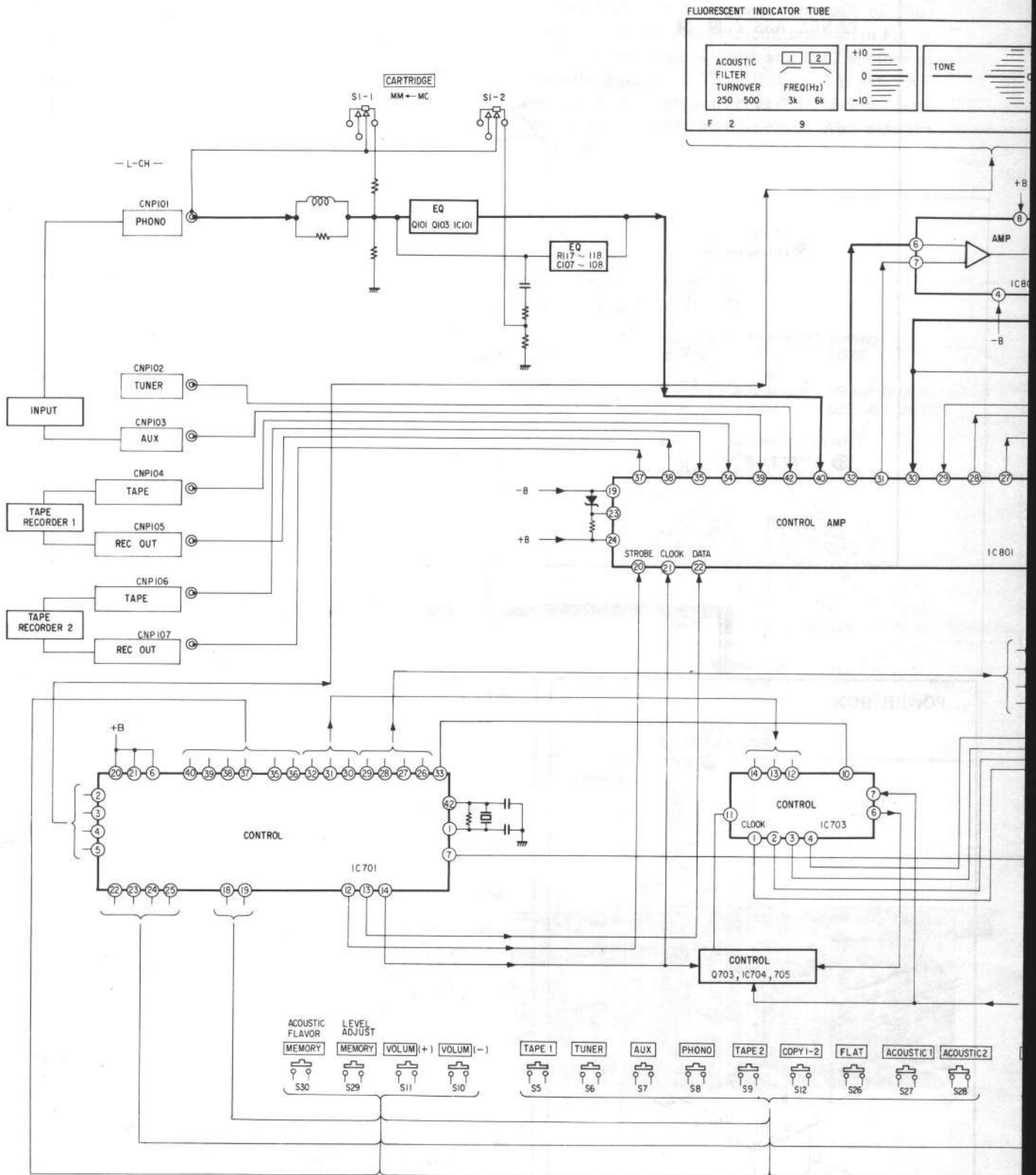

TA-AX5

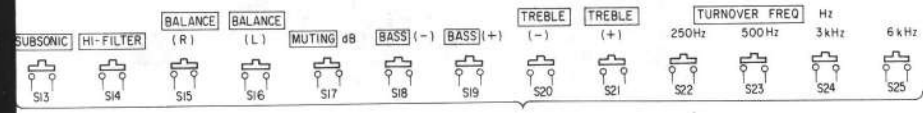
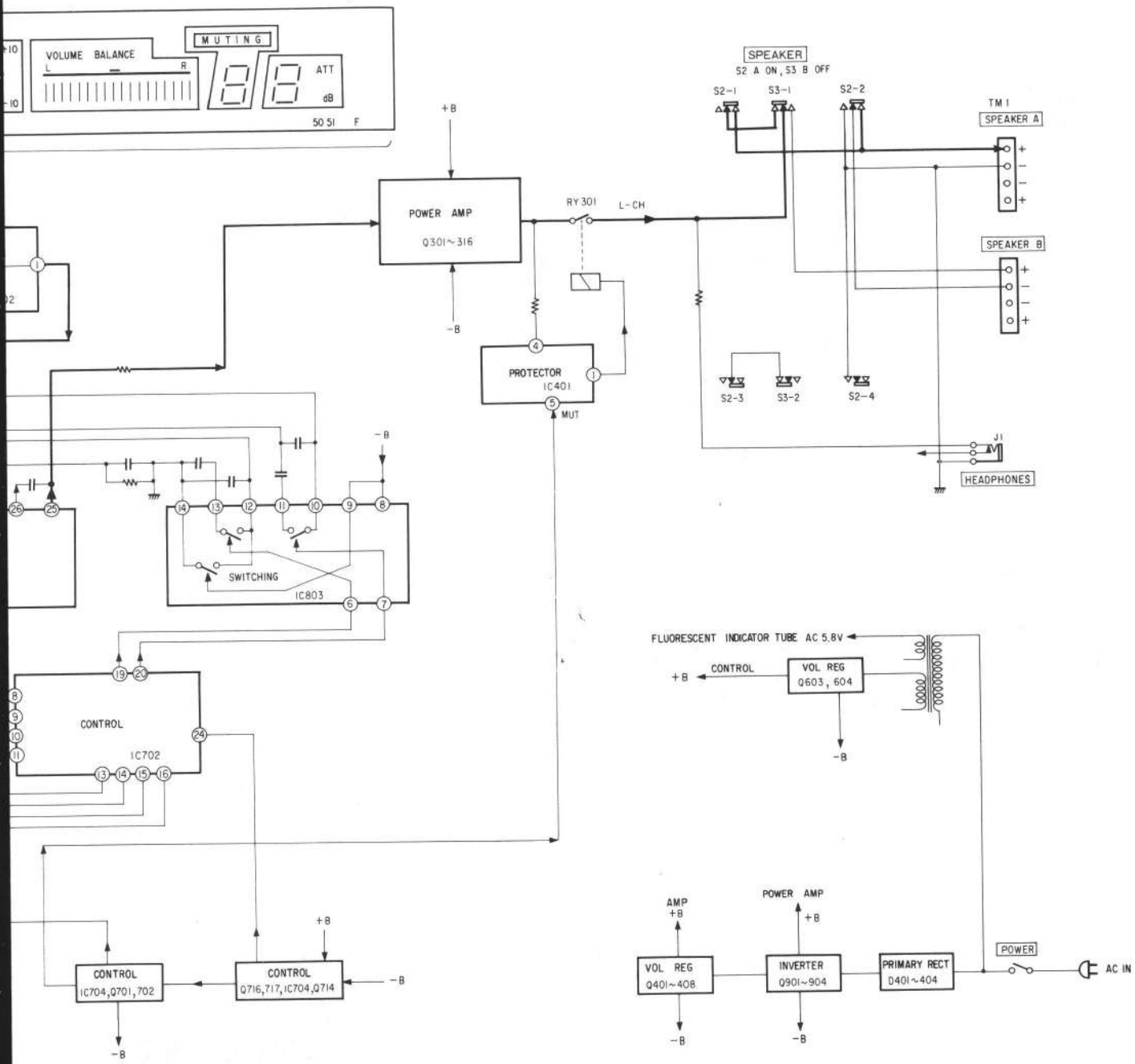

R-CH
SAME AS L-CH

1-2. SERVICING NOTE

1. Pulse Power Supply Board Repairing

This set has a pulse power-supply circuit which is quite different from a conventional power-supply circuit. The pulse power-supply directly rectifies and smooths the ac input power to produce the higher dc voltages required in the power-supply circuit. When servicing this set, note the following.

- a) To prevent unwanted radiation due to pulse signals in the pulse power-supply circuit, the pulse power-supply board is shielded by the aluminum diecast box.
- b) Take care that electrolytic capacitor which is used after the rectification of ac power source voltage is charged even if the POWER switch is turned off. Be sure to use a resistor of at least several hundred ohms to discharge the capacitor. Direct discharge by means of lead is dangerous.

2. Inverter Circuit Transistor Replacement

When any of inverter transistors (Q903, Q904) is broken, replace their transistors together. A pair of transistors with the same rank is provided for service field use.

Ref. No.	Part No.	Description
Q903, Q904	X-4866-605-1	Transistor Ass'y, service

3. Inverter Circuit Transformer Replacement

The lead wire arrangement for each of T901 and T902 in the inverter circuit is shown in Fig. A.

As the repair parts, T901 and T902 are formed by only iron core. Thus, if the coil is defective, arrange a new transformers as shown below. Note that the lead lengths must be exact. Also wind the coil carefully.

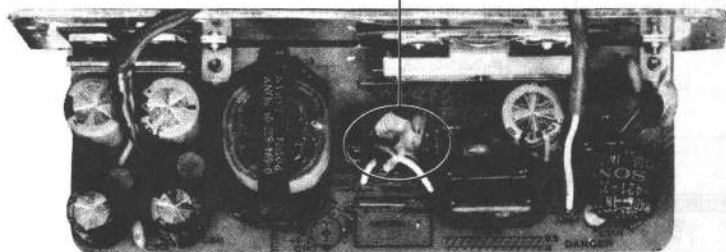
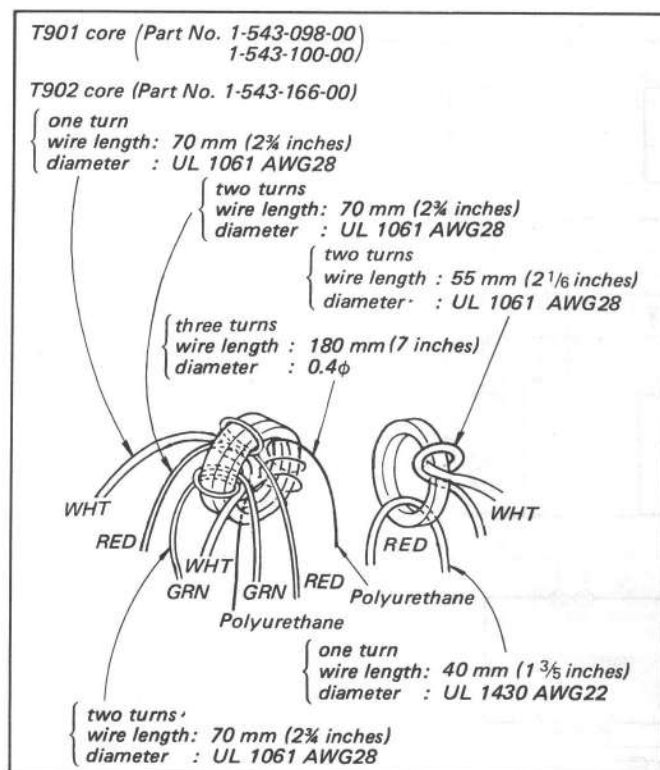
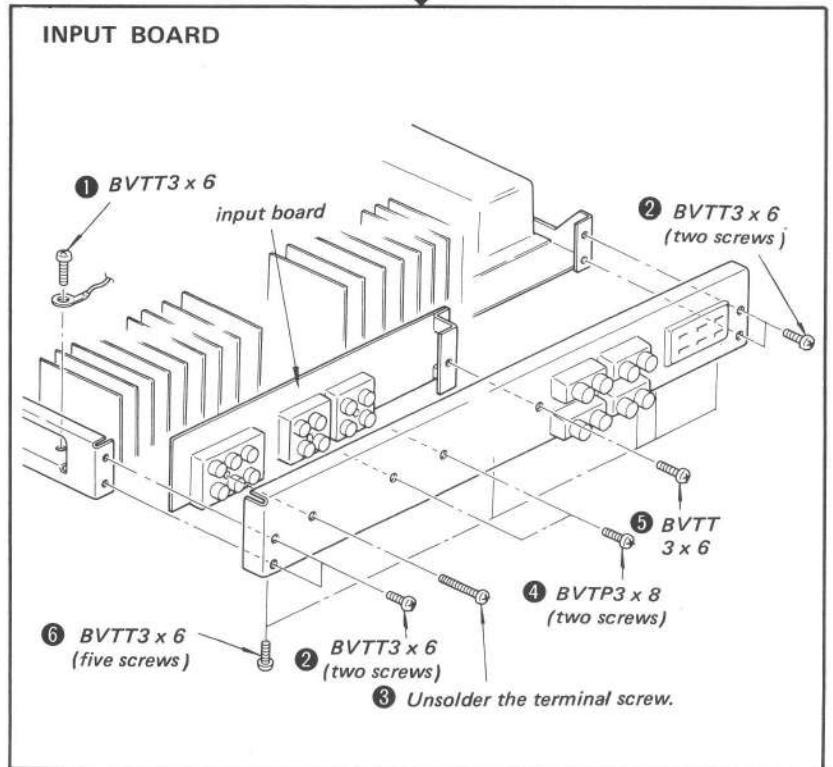
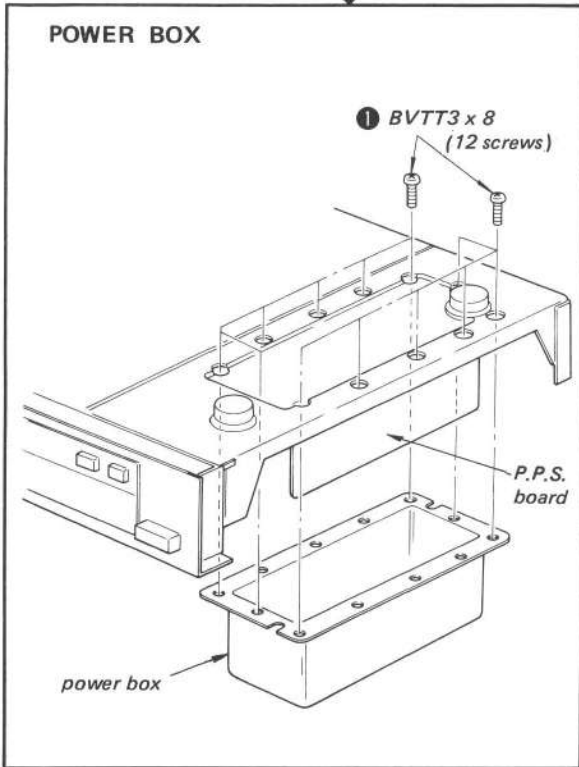
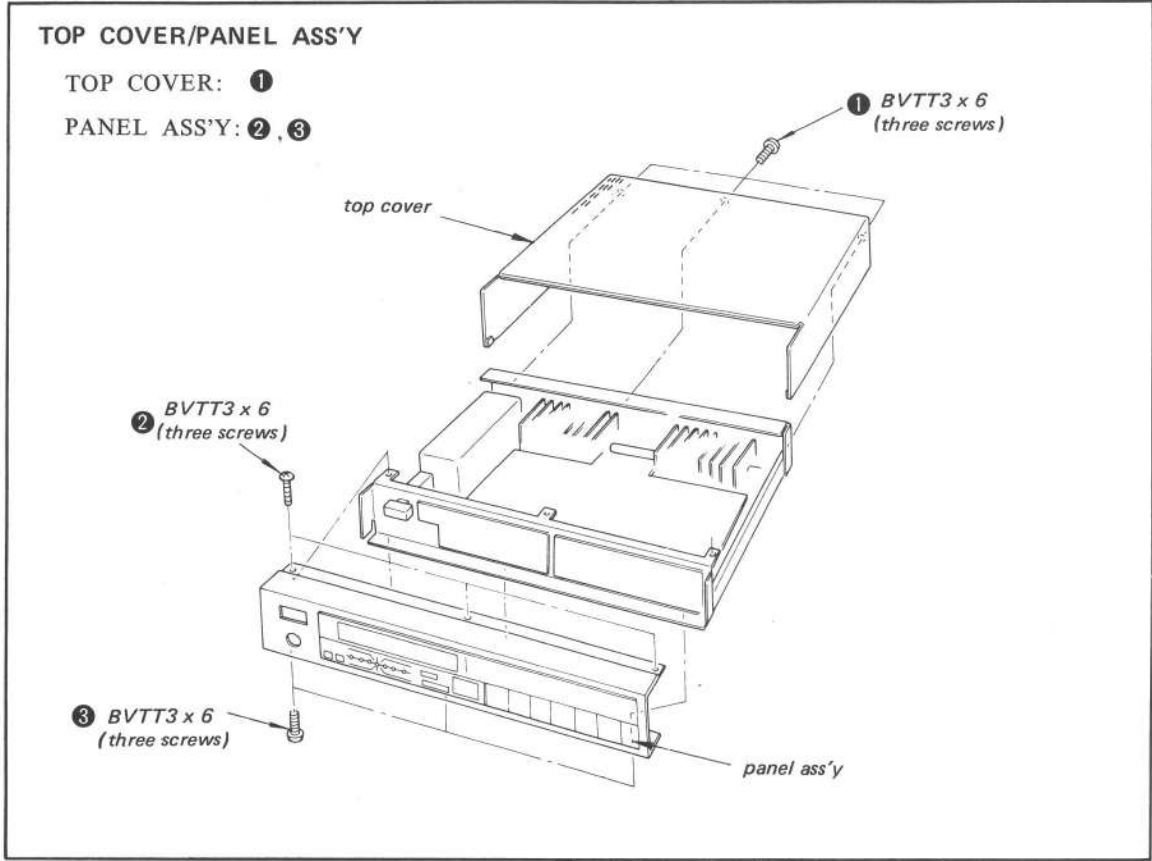

Fig. A

SECTION 2
DISASSEMBLY

Note: Follow the disassembly procedure in the numerical order given.



SECTION 3 ADJUSTMENT

3-1. ELECTRICAL ADJUSTMENT

Note:

1. DC BIAS and DC BALANCE adjustments should be made several minutes after the POWER switch is turned on (POWER ON.).
2. Make DC BIAS adjustment first.

3. Repeat DC BIAS and DC BALANCE adjustments two or three times.
4. After replacing the power transistors, DC BIAS and DC BALANCE adjustments should be made.

DC Bias Adjustment (with no signal input)

Procedure:

– L-CH –

Adjust RT302 for 10 mV readings.

– R-CH –

Adjust RT352 for 10 mV readings.

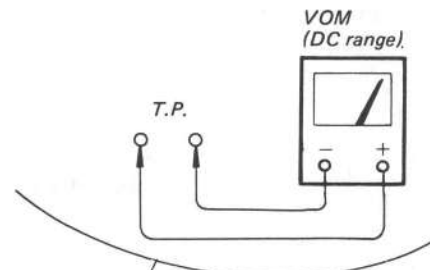
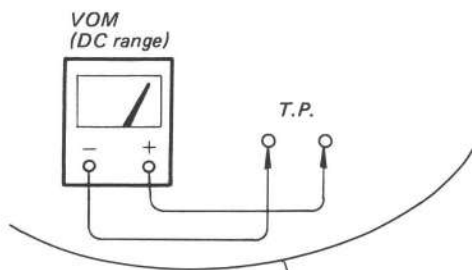

RT302
(L-CH)

RT352
(R-CH)

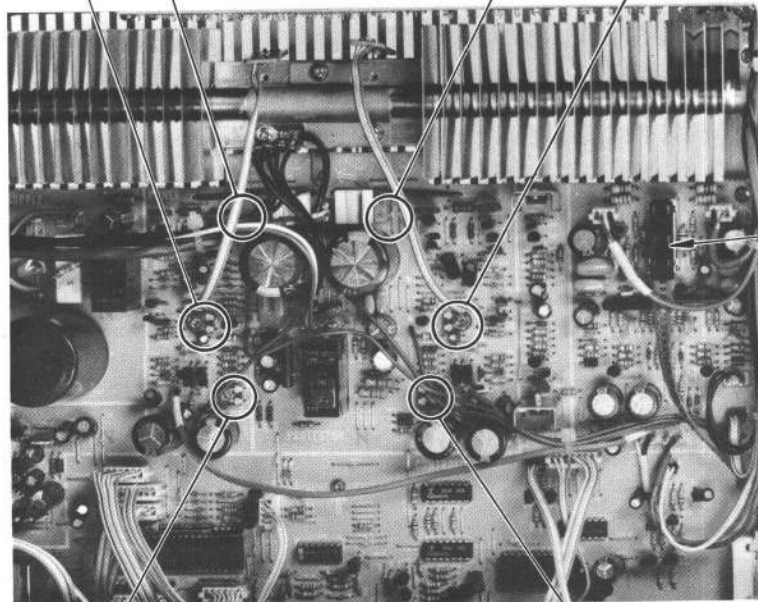

RT301
(L-CH)

RT351
(R-CH)

DC Balance Adjustment (with no signal input)

1. Turn Power switch ON. Connect a VOM across speaker terminals.

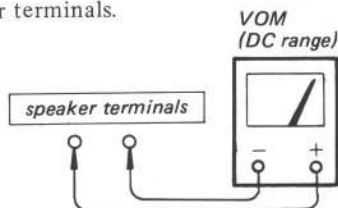

2. Adjust RT301 (L-CH) and RT351 (R-CH) for 0V reading on the VOM.

(Set the VOM high at first. After obtaining 0 V reading, lower the range gradually and adjust RT301 and RT351.)

IC801 CX789

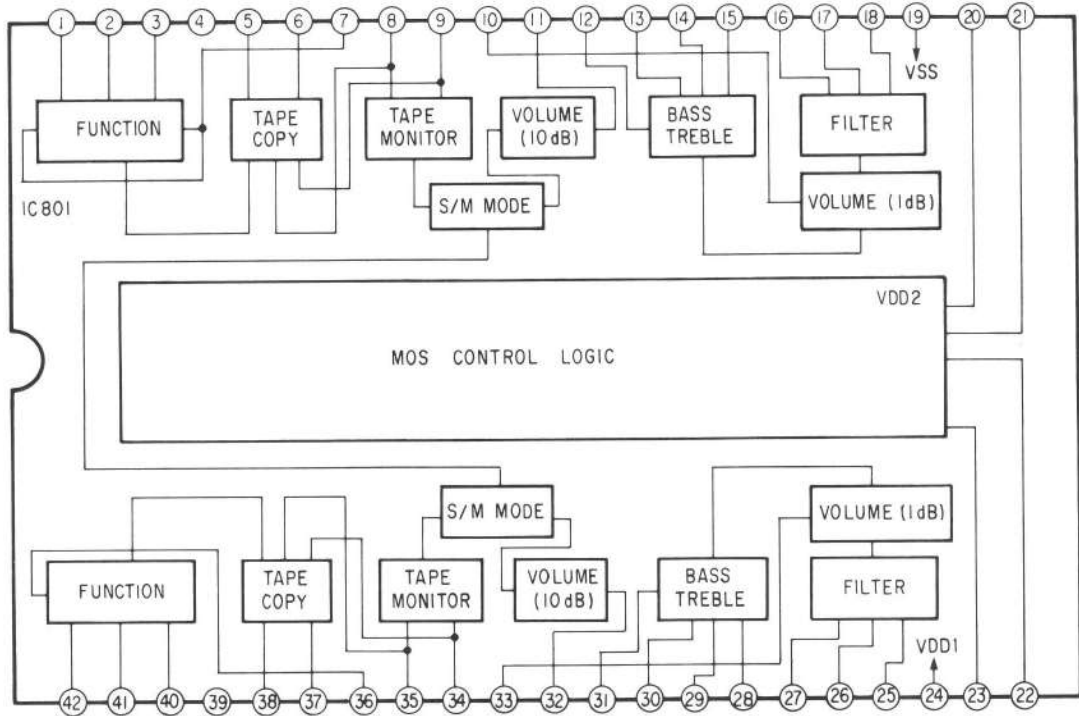

IC701 JPD553C

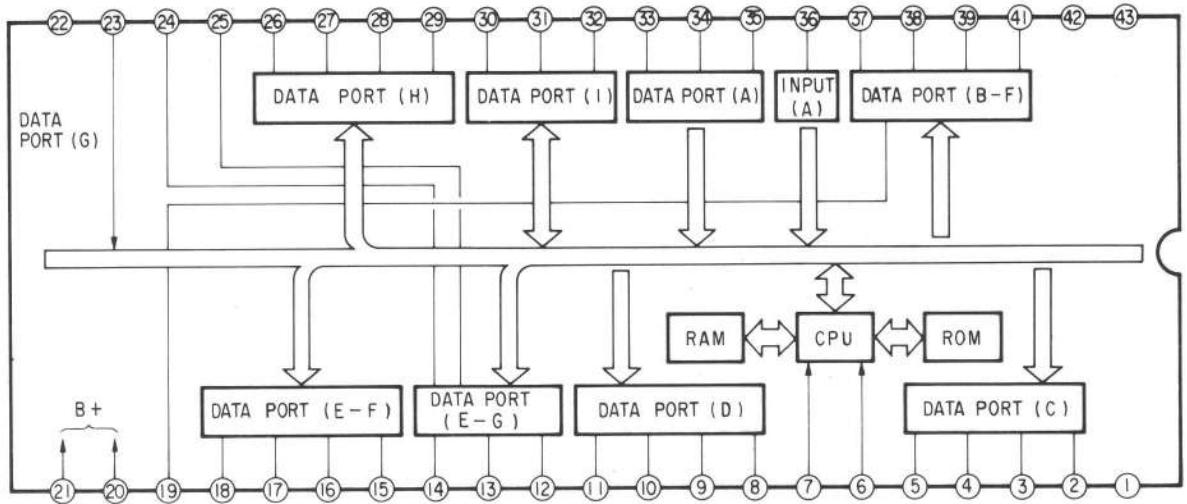

IC706 M54517P

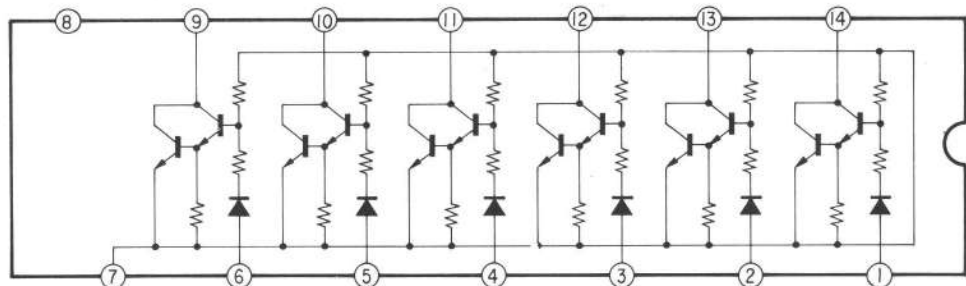

IC702 μ PD8243

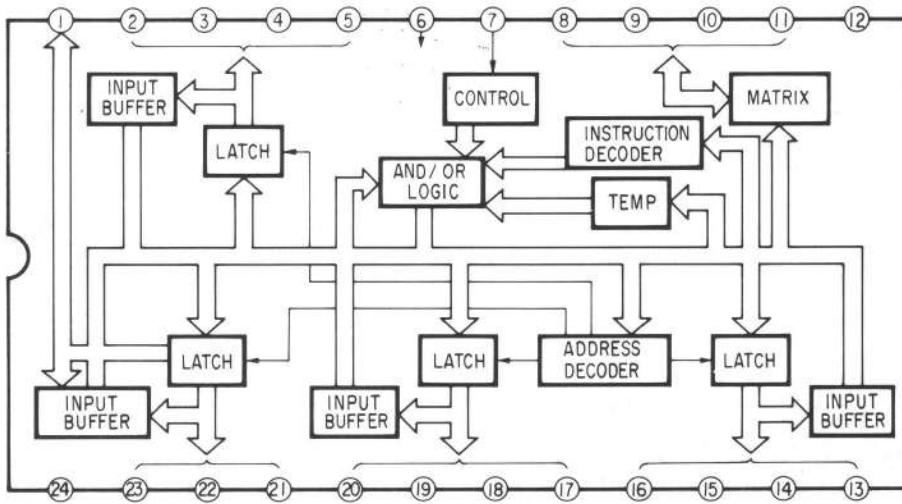

IC703 CX761A

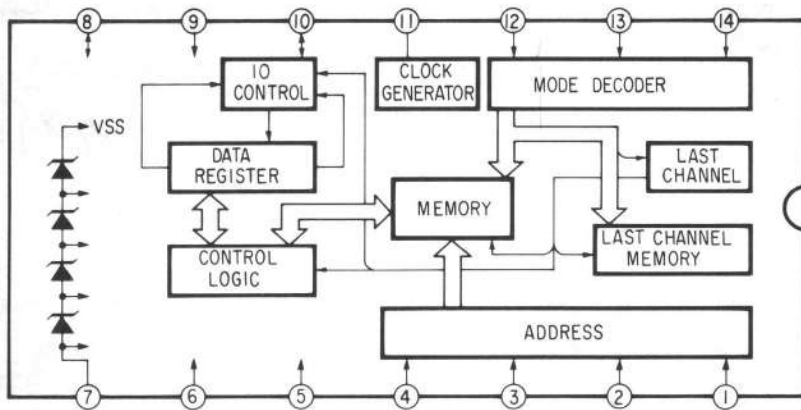

IC401 HAI2002

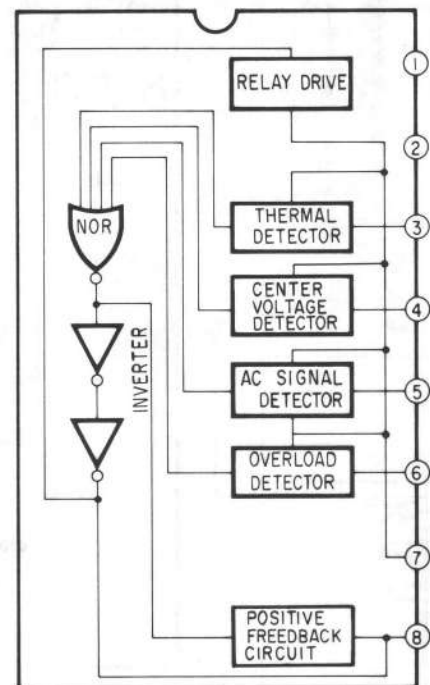

IC101, 151, 802, 804 CX550

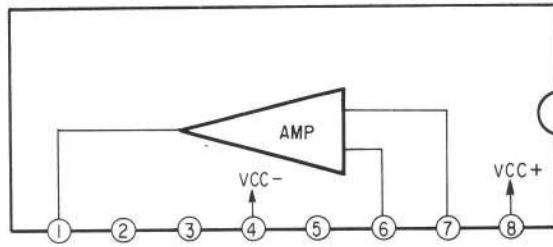

IC704 MB84069B

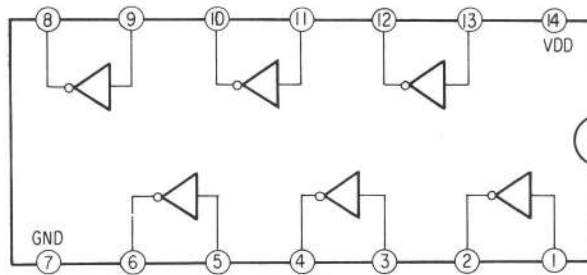



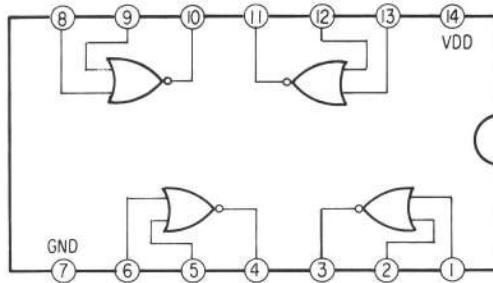



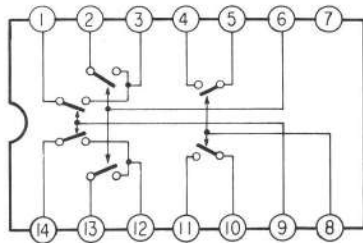



IC705 MB84001B

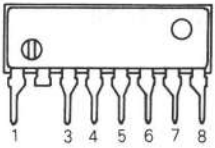
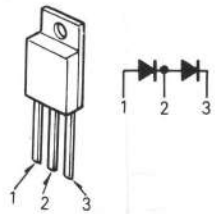
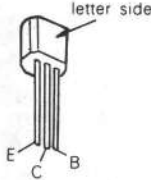

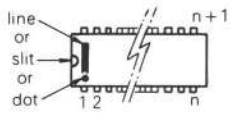
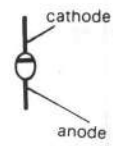
IC803 CX770

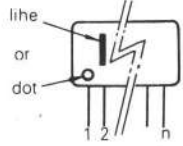
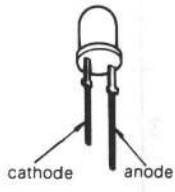
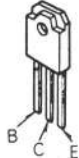
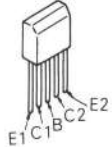
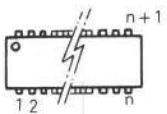
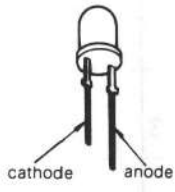

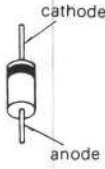
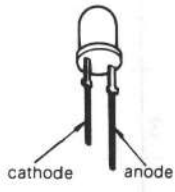
● Semiconductor Lead Layouts

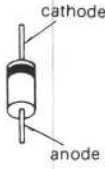
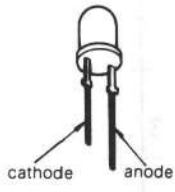
<p>2SA798</p>  <p>B C E C B</p>	<p>2SK30A</p>  <p>S G D</p>	<p>CX550</p>  <p>1 3 4 5 6 7 8</p>	<p>CTU-22U</p>  <p>1 2 3</p>
<p>2SA1175</p>  <p>letter side</p> <p>E C B</p>	<p>2SC2681 2SA1141</p>  <p>B C E</p>	<p>CX761A CX770 M.54517P</p>  <p>line or slit or dot</p> <p>1 2 n n+1</p> <p>(Top view)</p>	<p>MV12N</p>  <p>cathode</p> <p>anode</p>
<p>2SB734</p>  <p>E C B</p>	<p>2SC1364-7 2SC2545 2SA1015 2SB647</p>  <p>E C B</p>	<p>HA12002</p>  <p>line or dot</p> <p>1 2 n</p> <p>(Marking side view)</p>	<p>SLR54GC4 SLR54URC</p>  <p>cathode</p> <p>anode</p>
<p>2SC2769</p>  <p>B C E</p>	<p>2SC2291</p>  <p>E1 C1 B C2 E2</p>	<p>μPD553C141 CX789 μPD8243C MB84001B MB84069B</p>  <p>line or dot</p> <p>1 2 n n+1</p> <p>(Top view)</p>	<p>SLR54GC4 SLR54URC</p>  <p>cathode</p> <p>anode</p>
<p>2SD358 2SB528</p>  <p>B C E</p>	<p>2SA1027R</p>  <p>E C B</p>	<p>1S1555 10DF2 30DL4F EQA01-05R EQA01-06R HZ6C2L HZ12C2L 10E2 EQB01-28</p>  <p>cathode</p> <p>anode</p>	<p>SLR54GC4 SLR54URC</p>  <p>cathode</p> <p>anode</p>
<p>2SD809 2SB649A 2SD669A 2SB648 2SD668</p> <p>letter side</p>  <p>letter side</p> <p>E C B</p>	<p>2SA1049</p>  <p>B C E</p>	<p>1S1555 10DF2 30DL4F EQA01-05R EQA01-06R HZ6C2L HZ12C2L 10E2 EQB01-28</p>  <p>cathode</p> <p>anode</p>	<p>SLR54GC4 SLR54URC</p>  <p>cathode</p> <p>anode</p>

A

B

C

4-1. MOUNTING DIAGRAM

— Conductor Side —

1

- See page 11 for the Semiconductor Lead Layout.
- See pages 8 to 10 for block diagrams of IC.

IC	
Q	
D	
RT	

2

[INPUT BOARD]

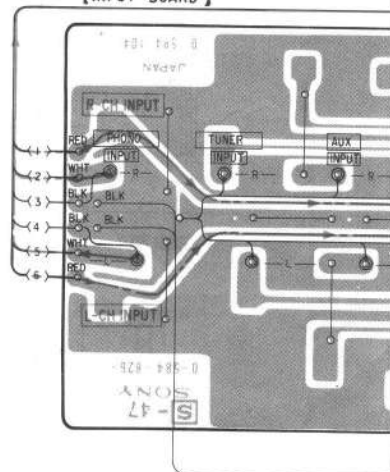

3

Note:

- Color code of sleeving over the end of the jacket.

4

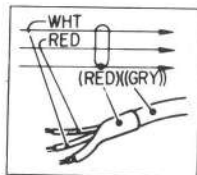

- ○ : parts extracted from the component side.
- ● : parts extracted from the conductor side.
- ■ : component-side pattern.
- ▨ : B + pattern
- ■ : B - pattern

5

D

E

IC801

IC804
IC802

801

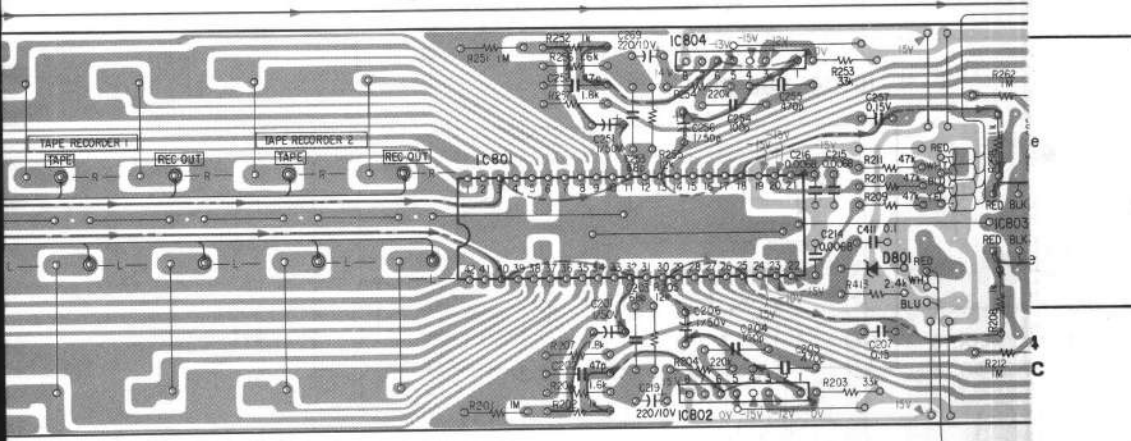

[FUNCTION BOARD]

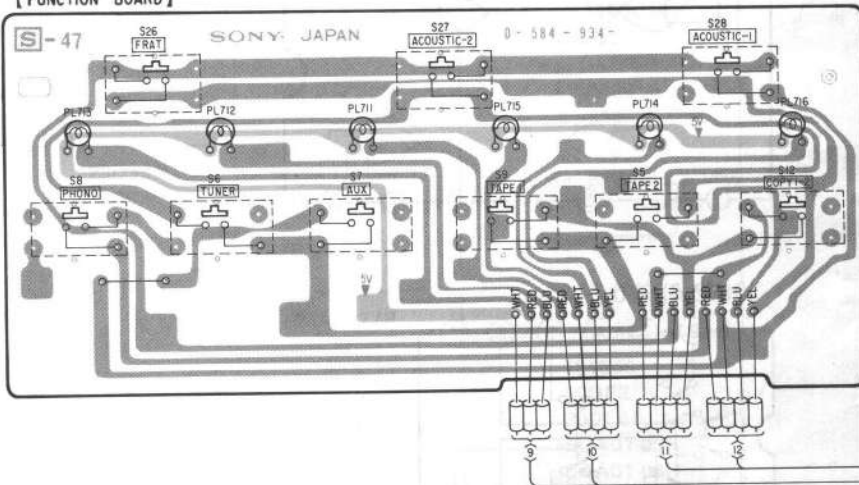

[RUBBER KEY SW BOARD]

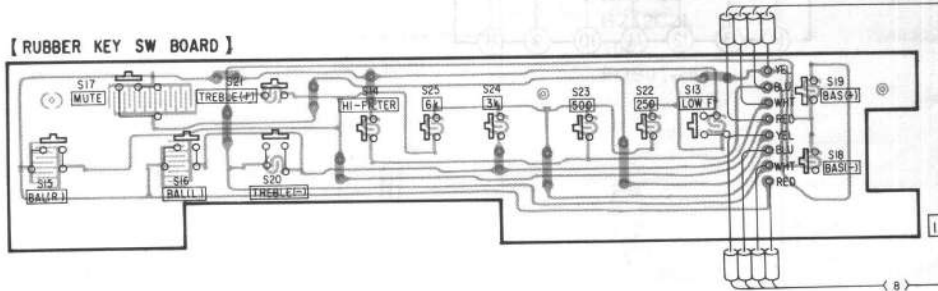

F

G

H

I

IC 803

IC151

IC101

IC706

IC702

IC705

IC703

152
153

151

709
708

711
710

101
102

103

714

403
713

402
404

406
405

401
712

305

358

363
408

367
354

351

357
717

716

362

364

360

365

356

361

702

701

316

103

306

307

352

355

351

353

354

366

703

701

407

RT 352

RT 351

[TRANSISTOR BOARD]

[AUDIO BOARD]

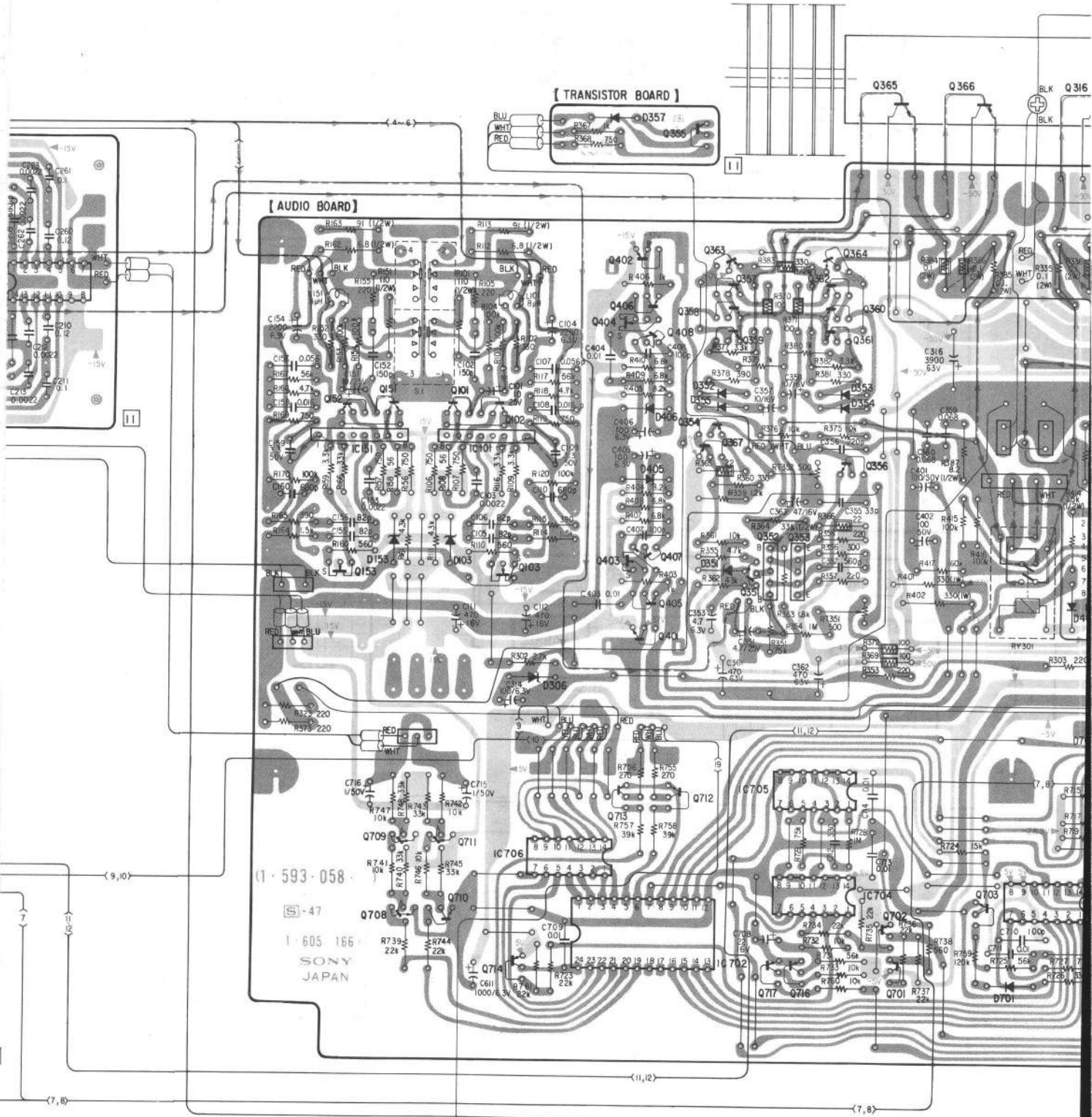

(1-593-058)

S-47

1-605 166
SONY
JAPAN

J

K

L

M

IC 401	315 706 314 310 705 707 312 311	IC 701	704 715	301	313 308 304 355 307 309 317	601	602	603	604	903 904	901	902	905 907 906 908	
5 704	303 304	706 707 708 709	302 305 301	703	357 702	601	403	401 607	402 603	404 606	604	904 903	902 901	905 907 906 908
	RT 301	RT 302												

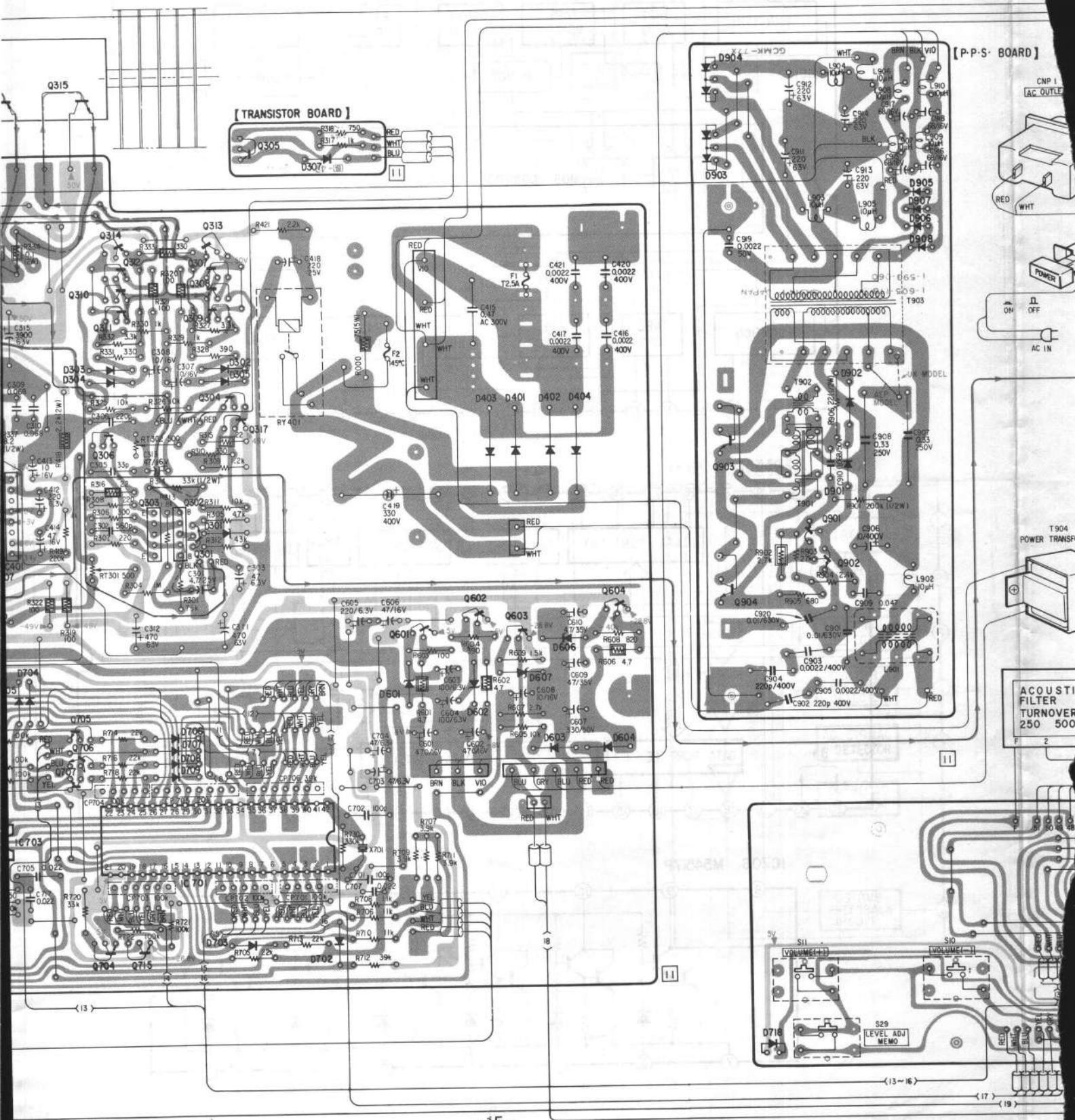

Q
IC
D
RT

1
2
3
4
5

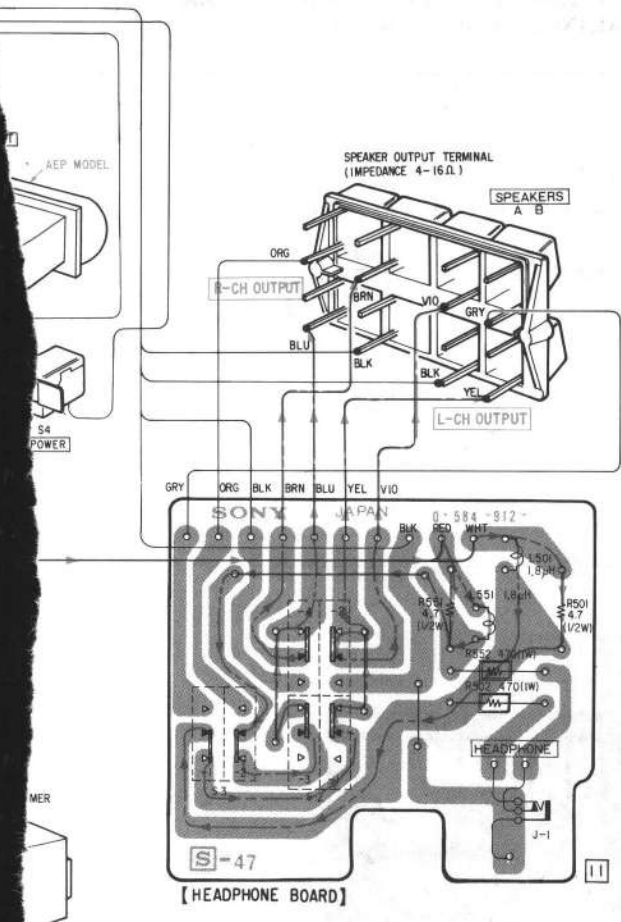

[HEADPHONE BOARD]

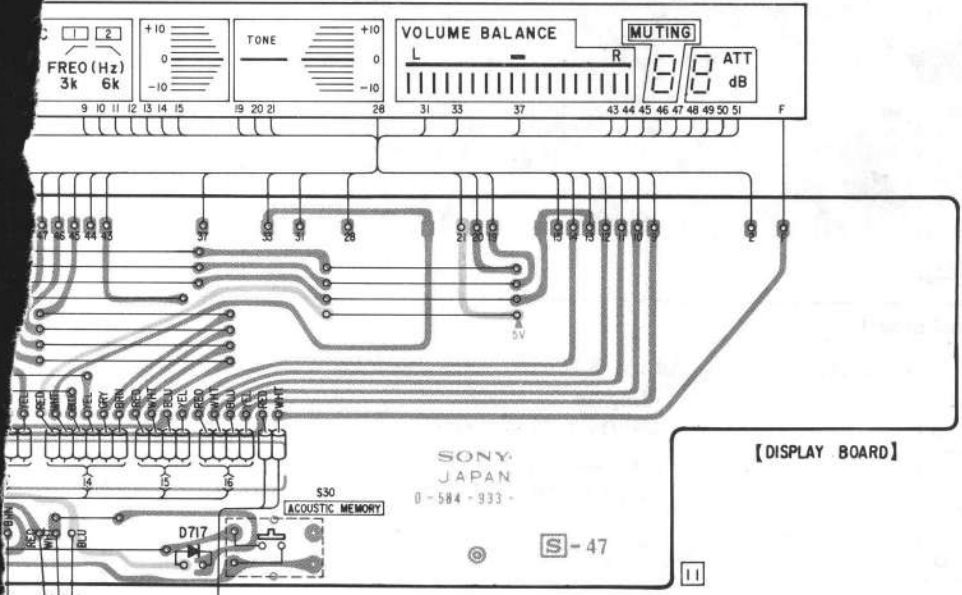

[DISPLAY BOARD]

4-2. SCHEMATIC DIAGRAM (1)

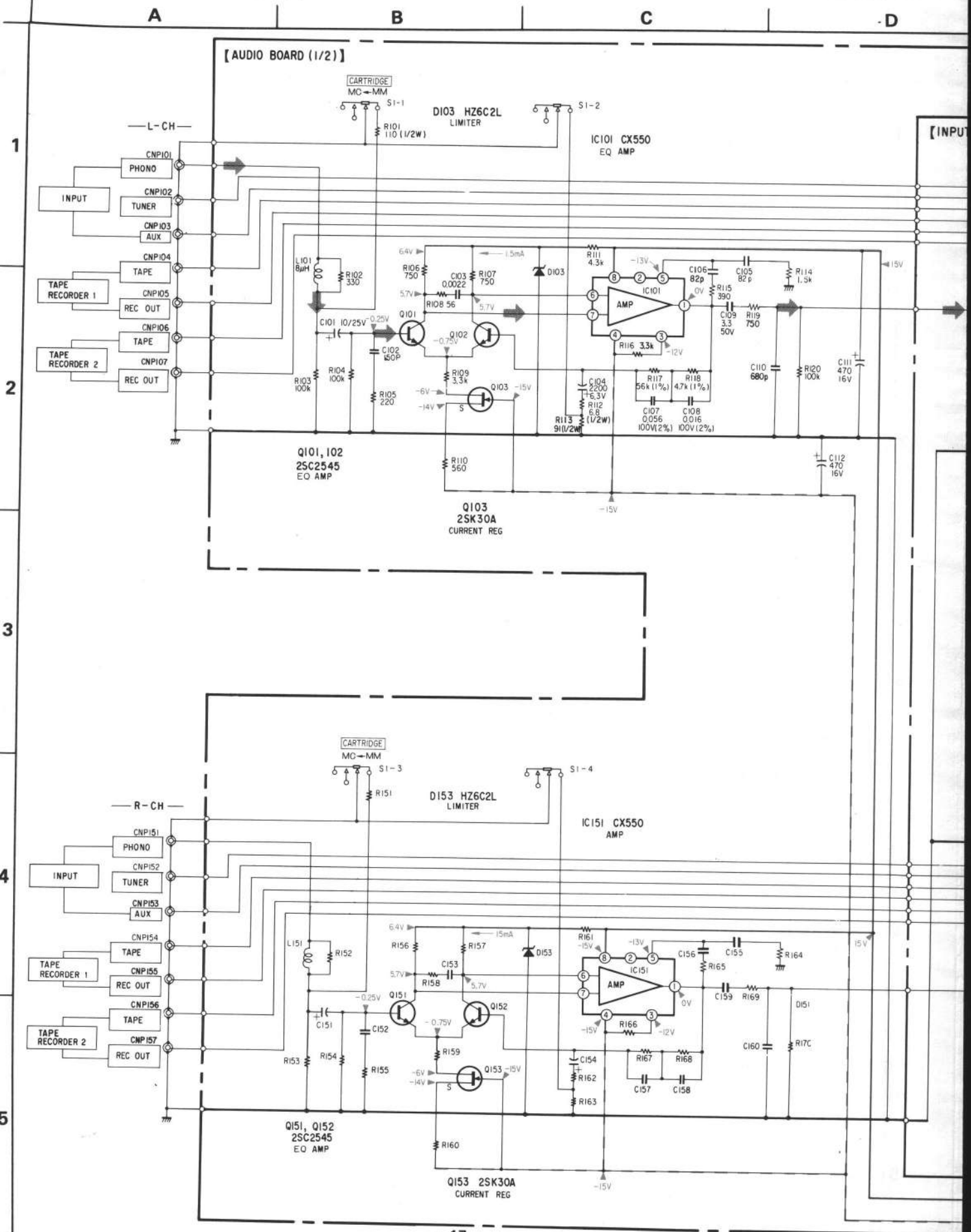

BOARD]

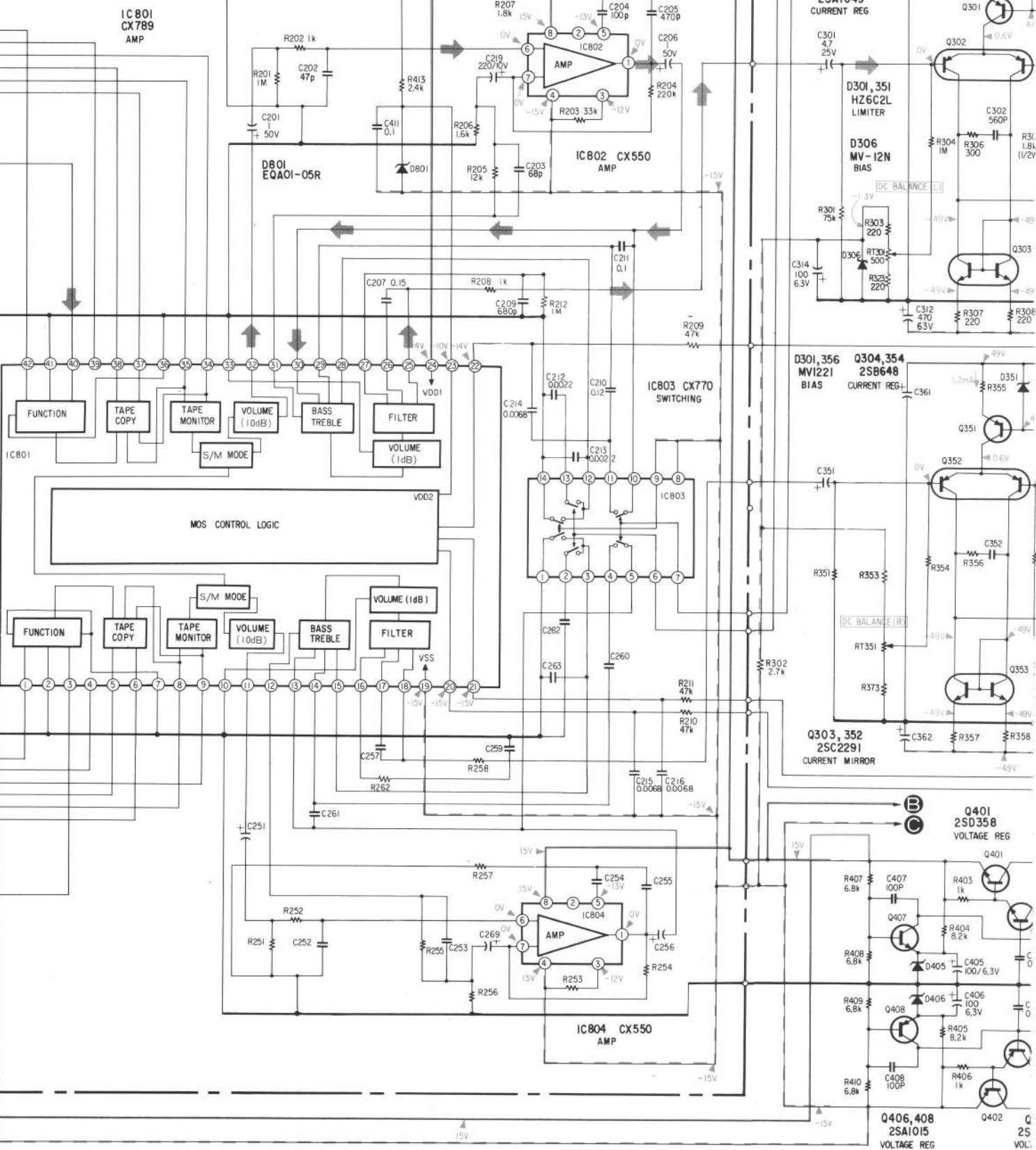

I

J

K

L

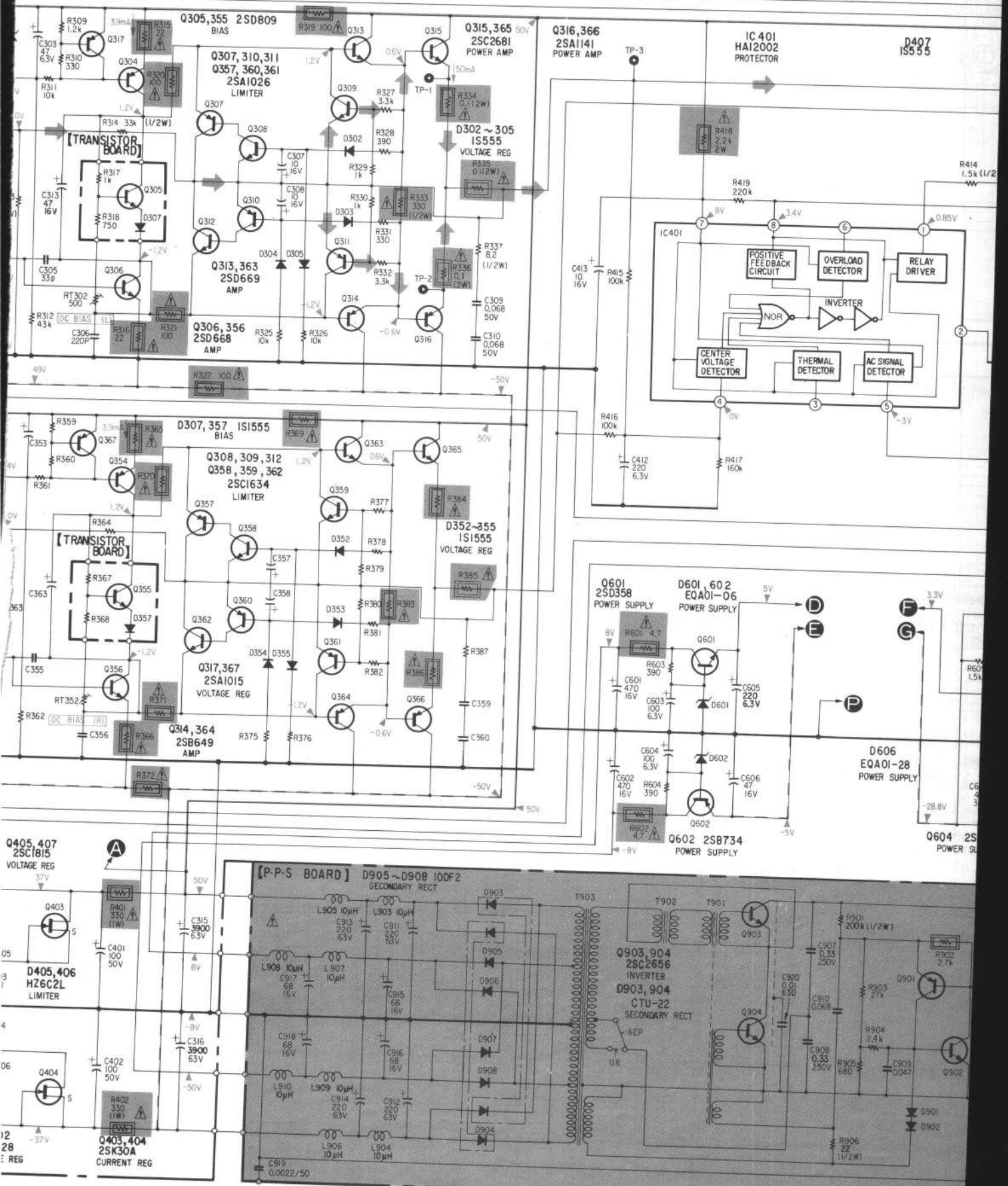

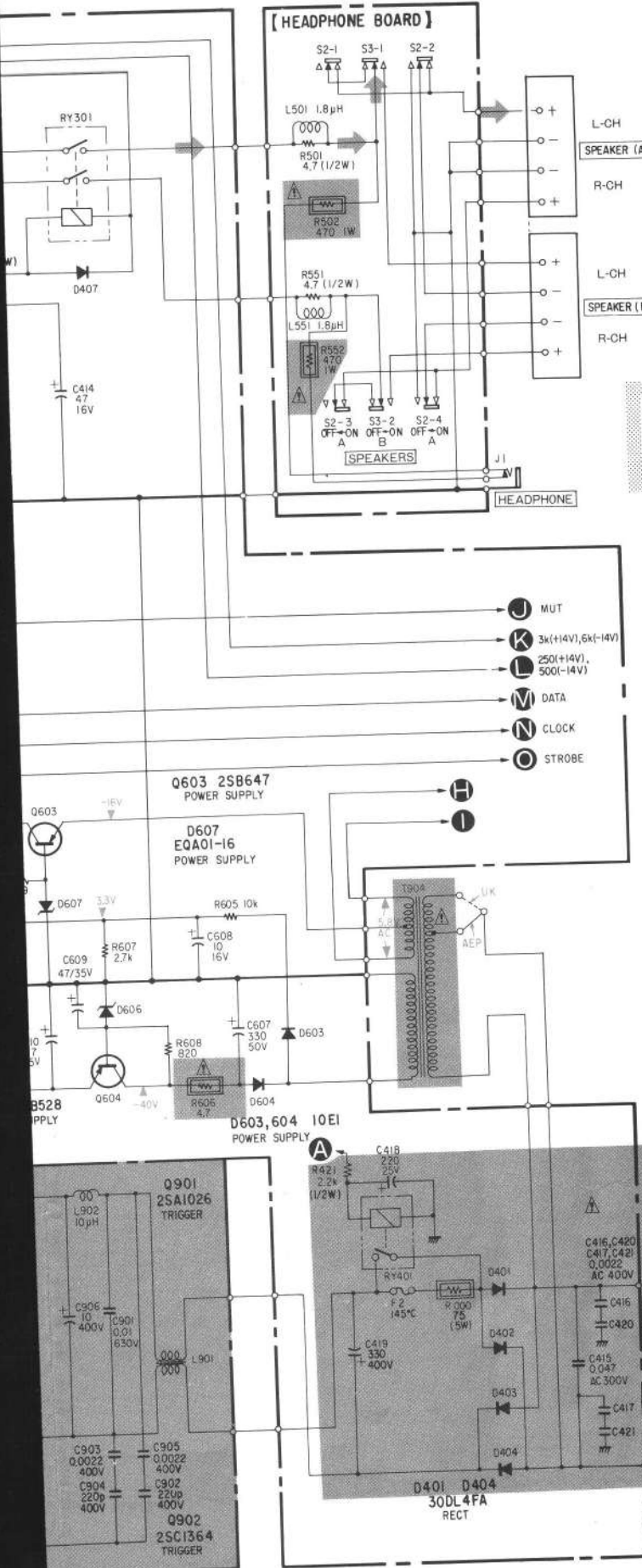

- All capacitors are in μF unless otherwise noted. pF : μμF
50WV or less are not indicated except for electrolytics and tantalums.
- All resistors are in ohms, 1/4 W unless otherwise noted.
kΩ : 1000 Ω, MΩ : 1000 kΩ
- : nonflammable resistor.
- : fusible resistor.
- : panel designation.
- : adjustment for repair.
- : B+ bus.
- : B- bus.
- : signal path

Note: The components identified by shading and mark are critical for safety. Replace only with part number specified.

4-3. SCHEMATIC DIAGRAM (2)

A

B

C

D

[DISPLAY BOARD]

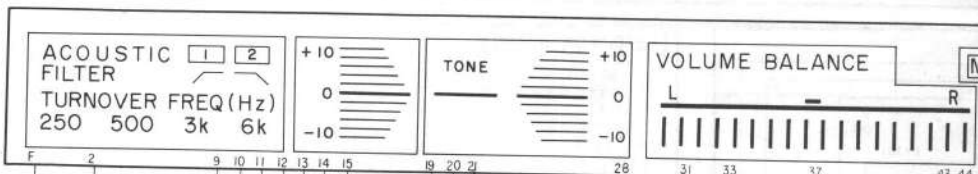

[AUDIO BOARD (1/2)]

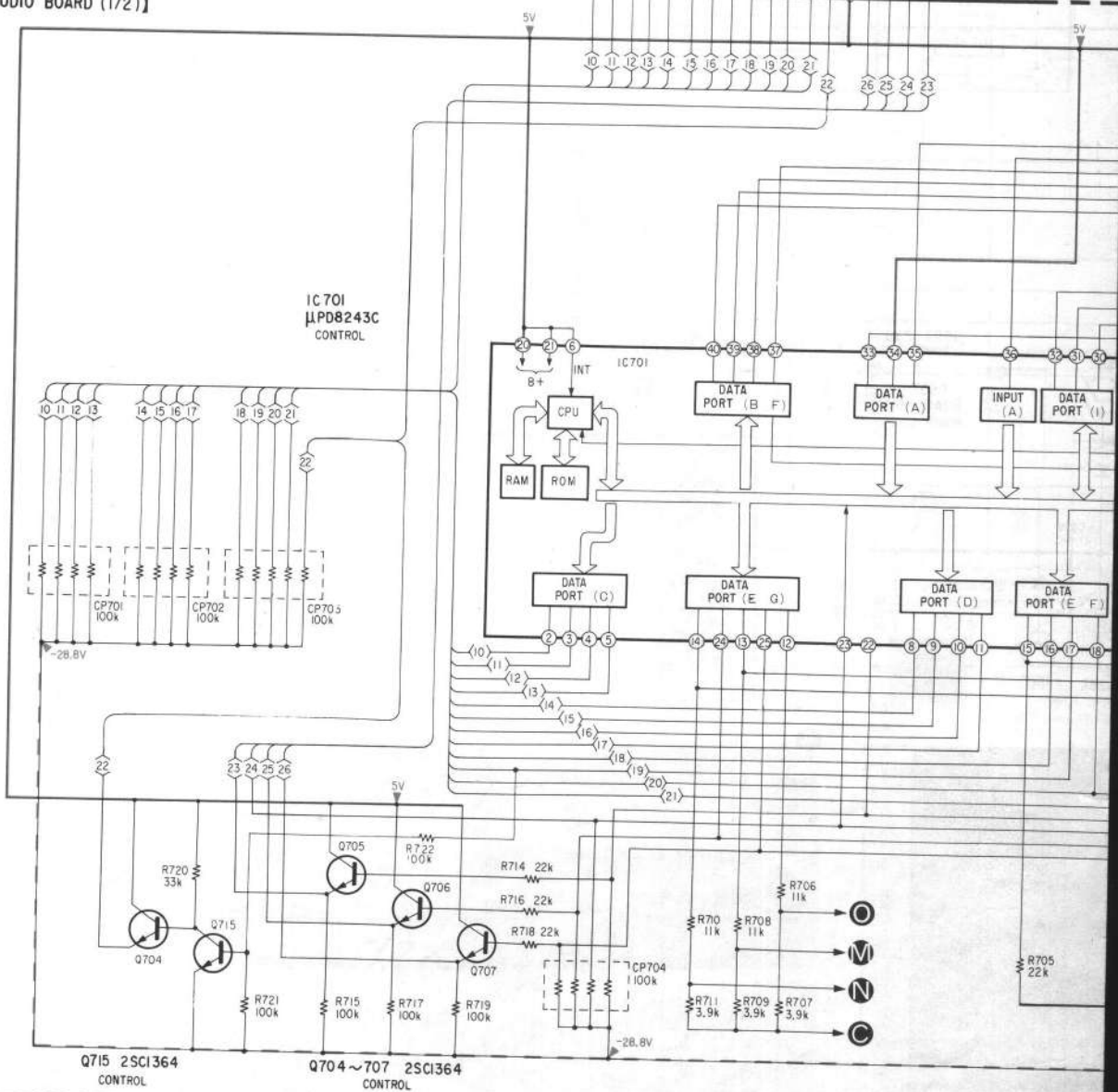

Note:

- All capacitors are in μF unless otherwise noted. pF : μpF
50WV or less are not indicated except for electrolytics and tantalums.

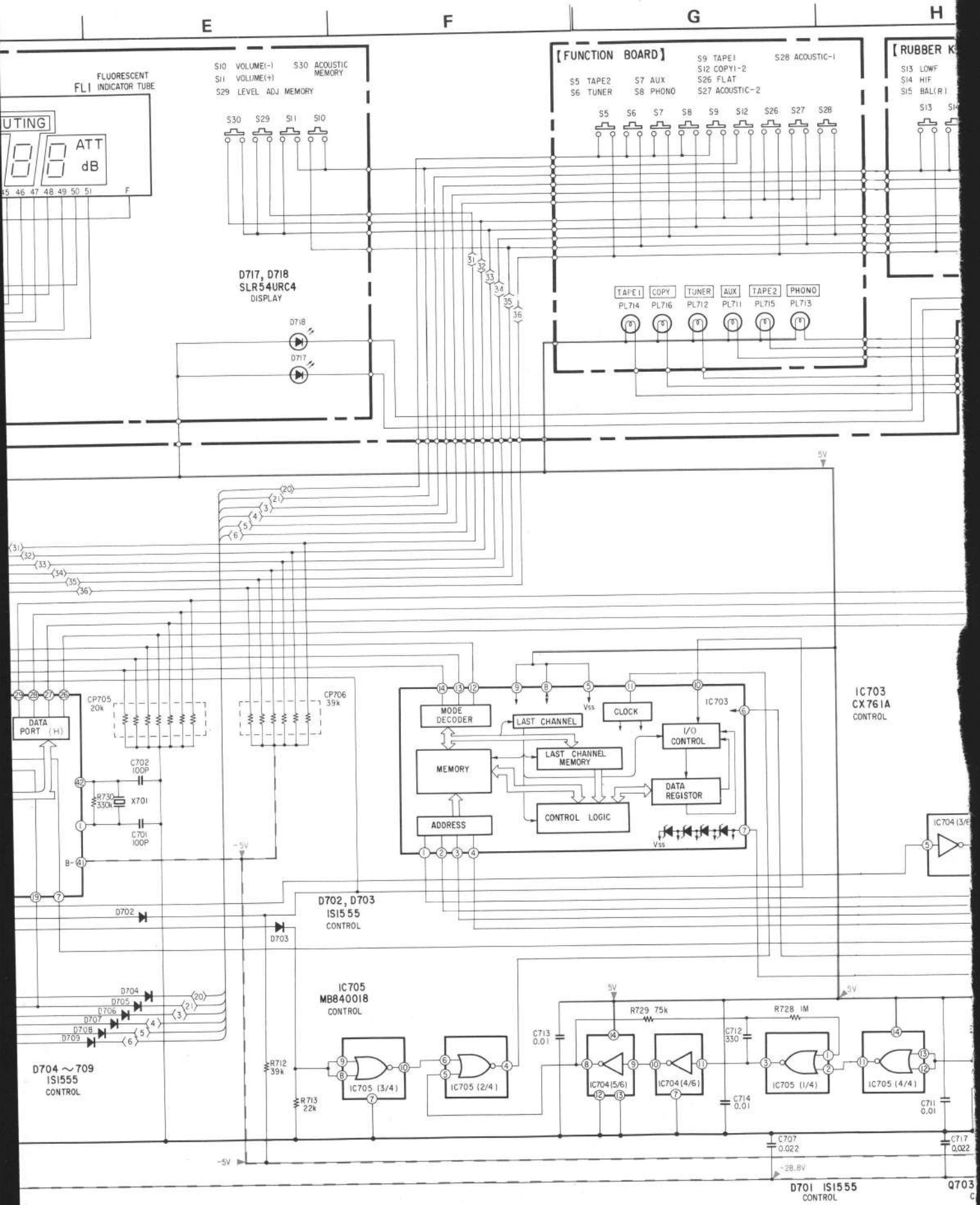

• All resistors are in ohms, ¼W unless otherwise noted.
 kΩ : 1000 Ω, MΩ : 1000 kΩ

• : nonflammable resistor. • : panel designator
 • : fusible resistor. • : adjustment

KEY SW BOARD]

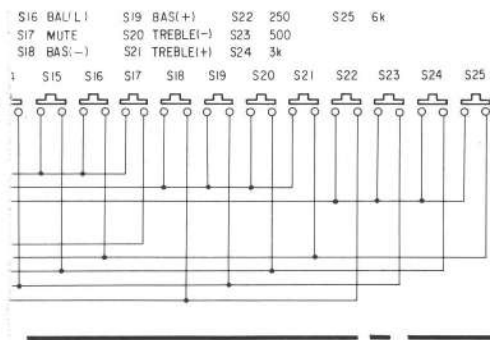

**Q709, Q711
2SA733
CONTROL**

**Q708, 710, 712, 713
2SC1364
CONTROL**

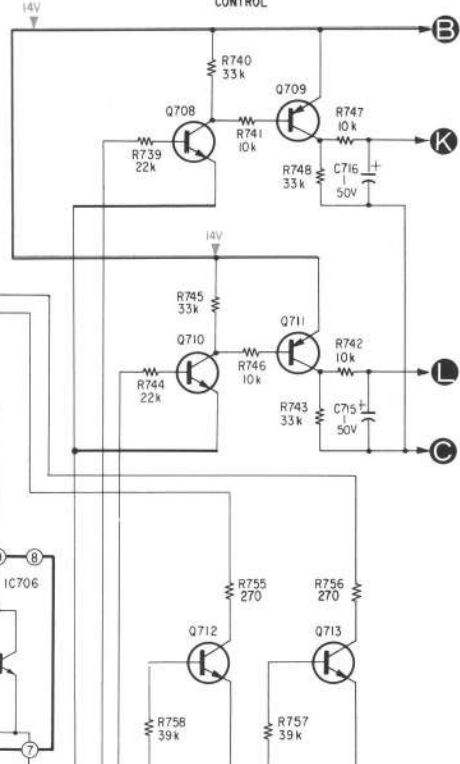

**IC706
M54517P
CONTROL**

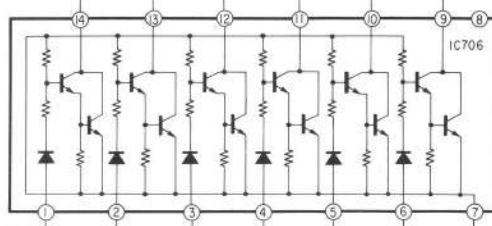

**IC702
μPD8243C
CONTROL**

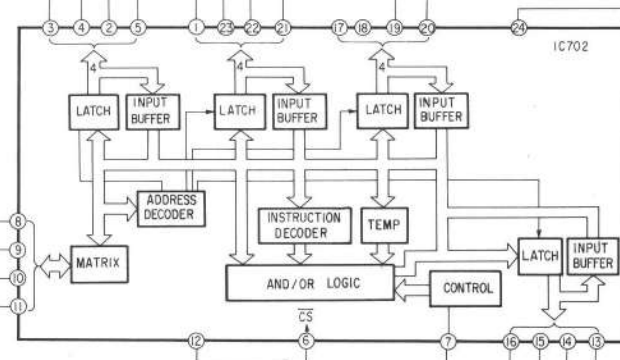

**IC704
MB84069B
CONTROL**

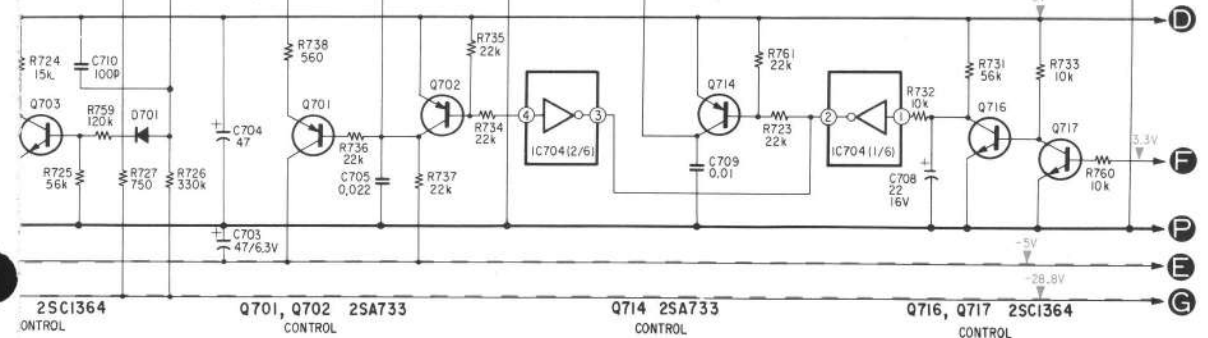

**2SC1364
CONTROL**

**Q701, Q702 2SA733
CONTROL**

**Q714 2SA733
CONTROL**

**Q716, Q717 2SC1364
CONTROL**

gnation. ● ——— : B+ bus.
t for repair. ● - - - - : B- bus.

SECTION 5
EXPLODED VIEWS AND PARTS LIST

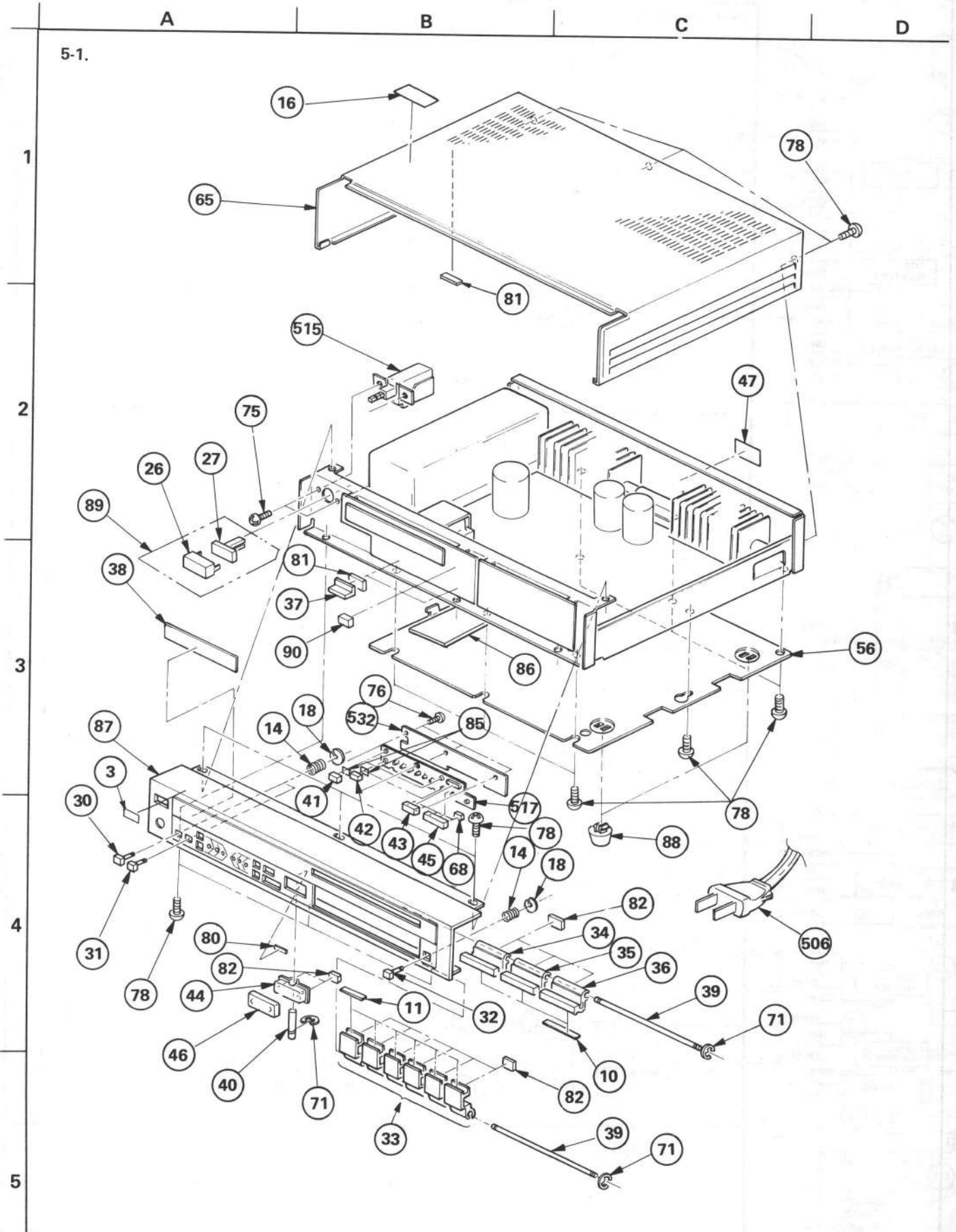

5-2. A B C D

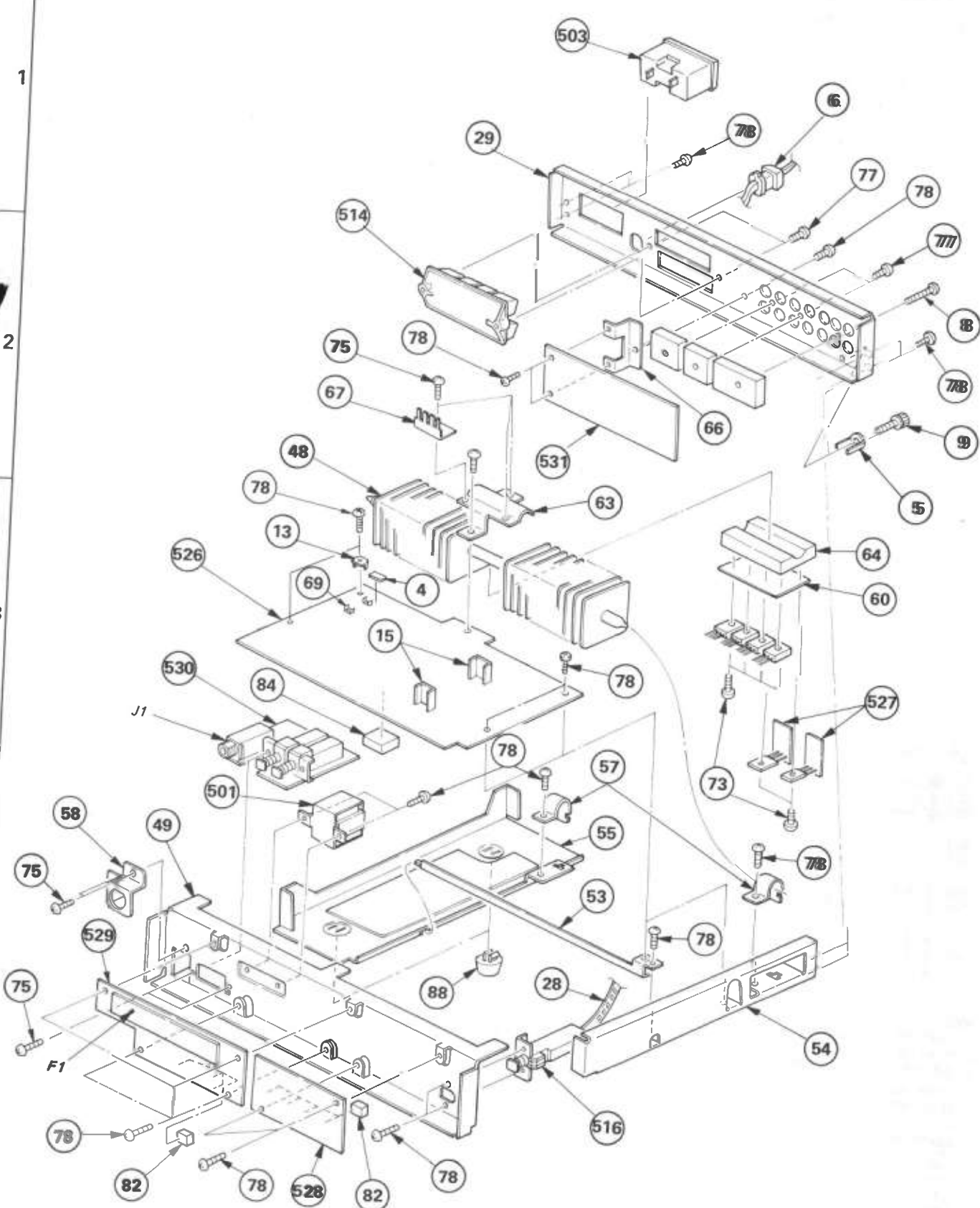

A

B

C

D

5-3.

1

2

3

4

5

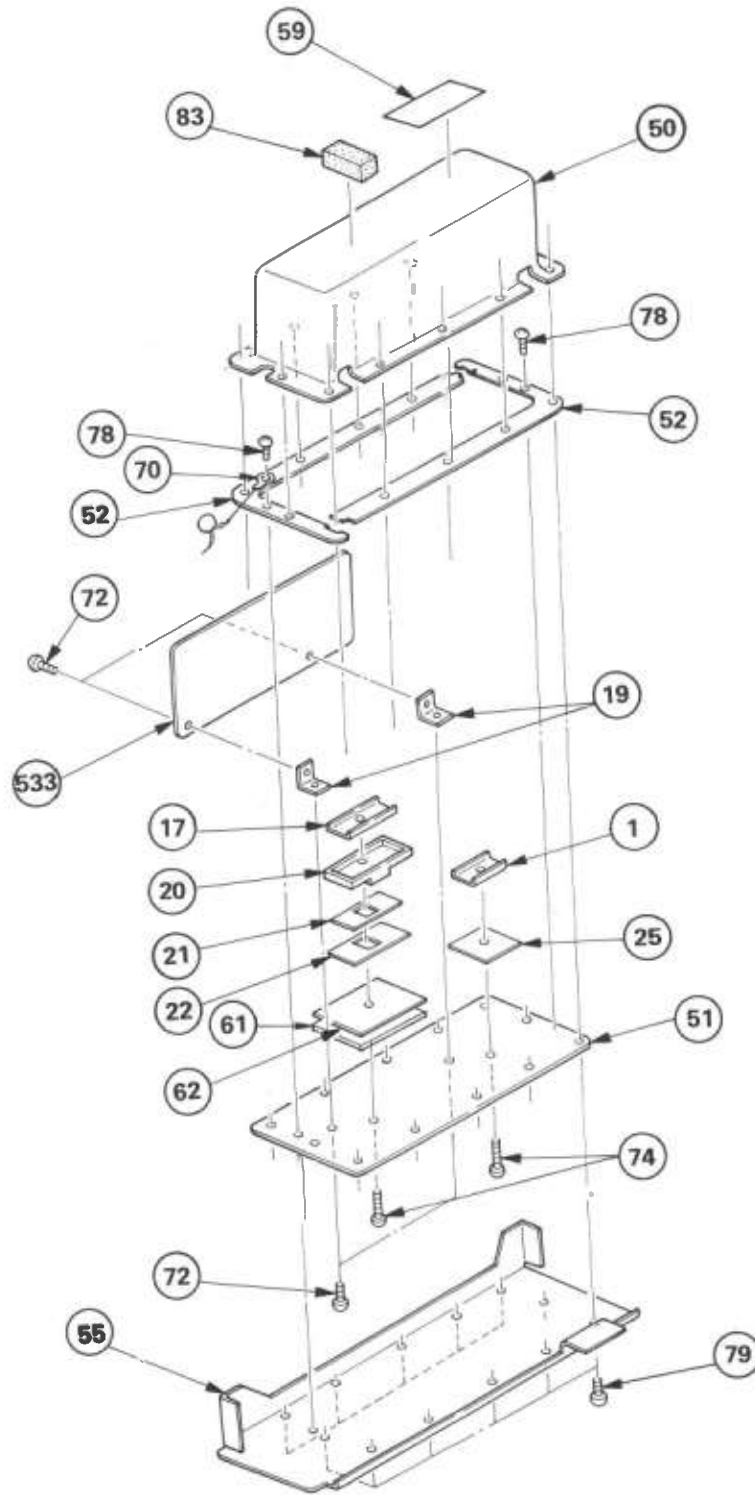

GENERAL SECTION

No.	Part No.	Description
1	2-275-902-00	BRACKET, TRANSISTOR
2	3-701-439-01	WASHER
3	3-701-690-00	(UK)....LABEL (MADE IN JAPAN)
4	3-701-948-18	LABEL, FUSE
5	3-701-993-00	SPACER, TERMINAL
6	3-703-244-00	BUSHING, CORD
7	3-703-249-01	SCREW, S TIGHT, +PTTWH 3X6
8	3-703-473-00	SCREW, TERMINAL
9	3-706-165-00	SCREW
10	3-831-441-XX	CUSHION, WINDOW
11	3-831-441-XX	PLATE, LIGHT INTERCEPTION
12	
13	4-835-639-00	PLATE, GROUND
14	4-854-743-00	SPRING, COMPRESSION
15	4-861-002-00	HEAT SINK
16	4-861-045-00	LABEL, CAUTION
17	4-862-237-00	BRACKET, INVERTER
18	4-862-338-00	RING, STOPPER
19	4-863-510-00	BRACKET, PC BOARD
20	4-866-315-00	RETAINER, TRANSISTOR
21	4-866-316-00	HEAT SINK
22	4-866-317-00	SARCON, TRANSISTOR
23	4-866-653-00	HEAT SINK (O)
24	4-866-654-00	HEAT SINK (S)
25	4-869-232-00	SHEET, INSULATING
26	4-871-322-01	CAP, POWER KNOB
27	4-871-323-00	BASE, POWER KNOB
28	4-873-753-11	BAND, JOINT
29	4-875-101-00	(UK)....PLATE, JACK
29	4-875-103-00	(AEP)....PLATE, JACK
30	4-875-114-01	KNOB (A)
31	4-875-114-11	KNOB (A)
32	4-875-114-21	KNOB (A)
33	4-875-115-01	KNOB (H)
34	4-875-116-01	KNOB (G)
35	4-875-116-11	KNOB (G)
36	4-875-116-21	KNOB (G)
37	4-875-117-00	KNOB (I) (MEMORY)
38	4-875-118-00	FILTER
39	4-875-119-00	SHAFT, KNOB
40	4-875-120-00	SHAFT, FULCRUM
41	4-875-121-01	KNOB (B)
42	4-875-121-11	KNOB (B)
43	4-875-122-00	KNOB (D)
44	4-875-125-00	MOLD, VOL KNOB
45	4-875-126-00	KNOB (E)

GENERAL SECTION

No.	Part No.	Description
46	4-875-127-00	KNOB (F) (VOLUME)
47	4-875-131-01	(AEP1,2)...LABEL, MODEL NUMBER
47	4-875-131-11	(AEP3)...LABEL, MODEL NUMBER
47	4-875-132-00	(UK).....LABEL, MODEL NUMBER
48	4-875-133-00	PIPE, HEAT
49	4-875-138-00	PANEL (A), SUB
50	4-875-139-00	BOX, POWER
51	4-875-140-00	HEAT SINK (P)
52	4-875-141-00	PACKING, SHIELD
53	4-875-153-00	CHANNEL (B)
54	4-875-154-00	PLATE, SIDE
55	4-875-155-00	PLATE, SIDE, L
56	4-875-156-00	PLATE, BOTTOM
57	4-875-157-00	HOLDER, PIPE
58	4-875-158-00	BRACKET, JACK
59	4-875-195-00	LABEL, PPS
60	4-875-404-00	SHEET (G), INSULATING
61	4-875-409-01	SHEET (A), INSULATING
62	4-875-409-11	SHEET (A), INSULATING
63	4-875-410-00	HOLDER, BLOCK
64	4-875-411-00	BLOCK, TR
65	4-875-412-00	TOP COVER
66	4-875-413-00	HOLDER, CHASSIS
67	4-875-437-00	PLATE, GROUND, LAPPING
68	4-875-446-00	RUBBER (C)
69	4-875-460-00	HOLDER, LAMP
70	7-623-508-01	LUG, 3
71	7-624-124-01	RETAINING, RING C-2
72	7-682-546-09	SCREW +B 3X5
73	7-682-548-01	SCREW +B 3X8
74	7-682-551-09	SCREW +B 3X14
75	7-682-947-01	SCREW +PSW 3X6
76	7-685-132-11	SCREW +P 2.6X5 TYPE2 NON-SLIT
77	7-685-646-11	SCREW +BVTP 3X8 TYPE2 N-S
78	7-685-871-01	SCREW +BVTT 3X6 (S)
79	7-685-872-01	SCREW +BVTT 3X8 (S)
80	4-848-642-00	CUSHION
81	9-911-839-XX	RUBBER (A)
82	9-911-840-XX	RUBBER (B)
83	9-911-842-XX	CUSHION (F)
84	9-911-846-XX	CUSHION
85	9-911-863-XX	SHEET (A)
86	9-911-863-XX	SHEET, INSULATING
87	A-4322-341-A	PANEL ASSY
88	X-3701-069-0	FOOT ASSY, M.F
89	X-4875-108-0	KNOB ASSY, POWER
90	3-565-343-01	CUSHION

NOTE:

- Items with no part number and no description are not stocked because they are seldom required for routine service.
- Items marked " ♣ " are not stocked since they are seldom required for routine service. Some delay should be anticipated when ordering these items.
- Due to standardization, parts with part numbers (Δ-ΔΔΔ-ΔΔΔ-XX or Δ-ΔΔΔΔ-ΔΔΔ-X) may be different from those used in the set.

CAPACITORS:

- All capacitors are in μF. Common capacitors are omitted. Refer to the following lists for their part numbers. MF:μF, PF:μμF.

RESISTORS

- All resistors are in ohms. Common 1/4W, 1/8W and 1/16W carbon resistors are omitted. Refer to the following lists for their part numbers.

- F : nonflammable

The components identified by shading and mark  are critical for safety. Replace only with part number specified.

COILS

- MMH : mH, UH : μH

ACCESSORY & PACKING MATERIAL

No.	Part No.	Description
101	3-701-630-00	BAG, POLYETHYLENE
102	3-783-512-11	MANUAL, INSTRUCTION
103	4-864-354-00	SHEET, POLYETHYLENE
104	4-873-610-00	SHEET, PROTECTION
105	4-875-448-00	CUSHION, UPPER
106	4-875-449-00	CUSHION, LOWER
107	4-875-469-00	INDIVIDUAL CARTON

ELECTRICAL PARTS

Ref.No.	Part No.	Description
501	▲.1-447-036-00	TRANSFORMER, POWER
502	●;1-508-817-00	14MM BASE POST
503	▲.1-526-694-00	(AEP)...OUTLET, AC
504	1-532-286-00	FUSE, TIME-LAG
505	1-533-131-00	HOLDER, FUSE
506	▲.1-534-817-XX	(AEP)...CORD, POWER
506	▲.1-551-884-00	(UK)...CORD, POWER
507	●;1-535-115-00	TERMINAL
508	●;1-535-116-00	TERMINAL
509	●;1-535-117-00	TERMINAL

NOTE:

- Items with no part number and no description are not stocked because they are seldom required for routine service.
- Items marked "●" are not stocked since they are seldom required for routine service. Some delay should be anticipated when ordering these items.
- Due to standardization, parts with part numbers (Δ-ΔΔΔ-ΔΔΔ-XX or Δ-ΔΔΔΔ-ΔΔΔ-X) may be different from those used in the set.

ELECTRICAL PARTS

Ref.No.	Part No.	Description
510	●;1-535-118-00	TERMINAL
511	●;1-535-135-00	BASE POST 14MM (10MM PITCH)
512	●;1-535-141-00	BASE POST 19MM (10MM PITCH) 4P
513	●;1-535-149-11	WIRE (30.0MM)
514	1-536-662-00	TERMINAL BOARD (SPEAKER)
515	▲.1-553-447-00	SWITCH, PUSH (AC POWER)
516	1-553-779-00	SWITCH, PUSH (REMOTE)
517	1-553-781-00	SWITCH, RUBBER KEY
518	●;1-560-060-00	PIN, CONNECTOR 2P
519	●;1-560-061-00	PIN, CONNECTOR 3P
520	●;1-560-062-00	PIN, CONNECTOR 4P
521	●;1-560-064-00	PIN, CONNECTOR 6P
522	●;1-560-065-00	PIN, CONNECTOR 8P
523	●;1-560-338-00	PIN, CONNECTOR 7P
524	●;1-561-296-00	SOCKET, CONNECTOR (3P)
525	●;1-561-448-00	SOCKET, CONNECTOR 8P
526	●;1-605-166-00	PC BOARD, AUDIO
526	●;A-4388-259-A	MOUNTED PCB, AUDIO
527	●;1-605-167-00	PC BOARD, TRANSISTOR
528	●;1-605-168-00	PC BOARD, FUNCTION
529	●;1-605-169-00	PC BOARD, DISPLAY
530	●;1-605-170-00	PC BOARD, HEADPHONE
531	●;1-605-171-00	PC BOARD, INPUT
531	●;A-4382-074-A	MOUNTED PCB, INPUT
532	●;1-605-172-00	PC BOARD, RUBBER KEY SW
533	●;1-605-173-00	PC BOARD, P.P.S
533	●;A-4394-238-A	MOUNTED PCB, POWER
C101	1-123-356-00	ELECT 10MF 20% 25V
C102	1-161-313-00	CERAMIC 150PF 10% 50V
C107	1-130-126-00	FILM 0.056MF 2% 100V
C108	1-130-125-00	FILM 0.016MF 2% 100V
C109	1-123-231-00	ELECT 3.3MF 20% 50V
C151	1-123-356-00	ELECT 10MF 20% 25V
C152	1-161-313-00	CERAMIC 150PF 10% 50V
C157	1-130-126-00	FILM 0.056MF 2% 100V
C158	1-130-125-00	FILM 0.016MF 2% 100V
C159	1-123-231-00	ELECT 3.3MF 20% 50V
C205	1-161-319-00	CERAMIC 470PF 10% 50V
C211	1-130-632-00	FILM 0.1MF 5% 50V
C219	1-123-308-00	ELECT 220MF 20% 10V
C255	1-161-319-00	CERAMIC 470PF 10% 50V
C261	1-130-632-00	FILM 0.1MF 5% 50V
C269	1-123-308-00	ELECT 220MF 20% 10V
C309	1-108-599-00	MYLAR 0.068MF 5% 50V
C310	1-108-599-00	MYLAR 0.068MF 5% 50V

CAPACITORS:

- All capacitors are in μ F. Common capacitors are omitted. Refer to the following lists for their part numbers. MF: μ F, PF: μ F.

RESISTORS

- All resistors are in ohms. Common 1/4W, 1/8W and 1/16W carbon resistors are omitted. Refer to the following lists for their part numbers.

- F: nonflammable

The components identified by shading and mark ▲ are critical for safety. Replace only with part number specified.

COILS

- MMH: mH, UH: μ H

ELECTRICAL PARTS

Ref.No.	Part No.	Description			
C359	1-108-599-00	MYLAR	0.068MF	5%	50V
C360	1-108-599-00	MYLAR	0.068MF	5%	50V
C411	1-130-632-00	FILM	0.1MF	5%	50V
C415	▲.1-130-701-51	FILM	0.47MF	20%	300V
C416	▲.1-161-734-00	CERAMIC	0.0022MF	20%	400V
C417	▲.1-161-734-00	CERAMIC	0.0022MF	20%	400V
C418	▲.1-123-334-00	ELECT	220MF	20%	25V
C419	▲.1-125-222-00	ELECT(BLOCK)	330MF	20%	400V
C901	▲.1-130-141-00	MYLAR	0.01MF	20%	630V
C902	▲.1-161-734-00	CERAMIC	0.0022MF	20%	400V
C904	▲.1-161-734-00	CERAMIC	0.0022MF	20%	400V
C906	▲.1-123-290-00	ELECT	10MF		400V
C907	▲.1-130-462-00	FILM	0.33MF	20%	250V
C908	▲.1-130-462-00	FILM	0.33MF	20%	250V
C909	▲.1-108-595-00	MYLAR	0.047MF	5%	50V
C910	▲.1-108-599-00	MYLAR	0.068MF	5%	50V
C911	▲.1-123-264-00	ELECT	220MF		63V
C912	▲.1-123-264-00	ELECT	220MF		63V
C913	▲.1-123-523-00	ELECT	220MF	20%	63V
C914	▲.1-123-523-00	ELECT	220MF	20%	63V
C915	▲.1-123-881-00	ELECT	68MF	20%	16V
C916	▲.1-123-881-00	ELECT	68MF	20%	16V
C917	▲.1-123-881-00	ELECT	68MF	20%	16V
C918	▲.1-123-881-00	ELECT	68MF	20%	16V
C919	▲.1-130-141-00	MYLAR	0.01MF	20%	630V
CNP101	1-507-741-00	JACK, PIN 6P			
CNP102	1-507-741-00	JACK, PIN 6P			
CNP103	1-507-741-00	JACK, PIN 6P			
CNP104	1-507-740-00	JACK, PIN 4P			
CNP105	1-507-740-00	JACK, PIN 4P			
CNP106	1-507-740-00	JACK, PIN 4P			
CNP107	1-507-740-00	JACK, PIN 4P			
CNP151	1-507-741-00	JACK, PIN 6P			
CNP152	1-507-741-00	JACK, PIN 6P			
CNP153	1-507-741-00	JACK, PIN 6P			
CNP154	1-507-740-00	JACK, PIN 4P			
CNP155	1-507-740-00	JACK, PIN 4P			
CNP156	1-507-740-00	JACK, PIN 4P			
CNP157	1-507-740-00	JACK, PIN 4P			
CP701	1-231-619-00	COMPOSITION CIRCUIT BLOCK			
CP702	1-231-619-00	COMPOSITION CIRCUIT BLOCK			
CP704	1-231-619-00	COMPOSITION CIRCUIT BLOCK			
CP705	1-231-659-00	COMPOSITION CIRCUIT BLOCK			
CP706	1-232-052-00	COMPOSITION CIRCUIT BLOCK			

ELECTRICAL PARTS

Ref.No.	Part No.	Description
D103	8-719-910-68	DIODE HZ6C2L
D153	8-719-910-68	DIODE HZ6C2L
D301	8-719-910-68	DIODE HZ6C2L
D302	8-719-815-55	DIODE 1S1555
D303	8-719-815-55	DIODE 1S1555
D304	8-719-815-55	DIODE 1S1555
D305	8-719-815-55	DIODE 1S1555
D306	8-719-912-00	DIODE MV-12N
D307	8-719-815-55	DIODE 1S1555
D351	8-719-910-68	DIODE HZ6C2L
D352	8-719-815-55	DIODE 1S1555
D353	8-719-815-55	DIODE 1S1555
D354	8-719-815-55	DIODE 1S1555
D355	8-719-815-55	DIODE 1S1555
D357	8-719-815-55	DIODE 1S1555
D401	▲.8-719-230-34	DIODE 30DL4F
D402	▲.8-719-230-34	DIODE 30DL4F
D403	▲.8-719-230-34	DIODE 30DL4F
D404	▲.8-719-230-34	DIODE 30DL4F
D405	8-719-910-68	DIODE HZ6C2L
D406	8-719-910-68	DIODE HZ6C2L
D407	8-719-815-55	DIODE 1S1555
D601	8-719-936-06	DIODE EQA01-06R
D602	8-719-936-06	DIODE EQA01-06R
D603	8-719-200-02	DIODE 10E2
D604	8-719-200-02	DIODE 10E2
D606	8-719-931-28	DIODE EQB01-28
D701	8-719-815-55	DIODE 1S1555
D702	8-719-815-55	DIODE 1S1555
D703	8-719-815-55	DIODE 1S1555
D704	8-719-815-55	DIODE 1S1555
D705	8-719-815-55	DIODE 1S1555
D706	8-719-815-55	DIODE 1S1555
D707	8-719-815-55	DIODE 1S1555
D708	8-719-815-55	DIODE 1S1555
D709	8-719-815-55	DIODE 1S1555
D711	8-719-905-47	DIODE SLR54GC4
D712	8-719-905-47	DIODE SLR54GC4
D713	8-719-815-55	DIODE 1S1555
D714	8-719-905-47	DIODE SLR54GC4
D715	8-719-905-47	DIODE SLR54GC4
D716	8-719-905-40	DIODE SLR54URC
D717	8-719-905-40	DIODE SLR54URC
D718	8-719-905-40	DIODE SLR54URC
D801	8-719-936-05	DIODE EQA01-05R

NOTE:

- Items with no part number and no description are not stocked because they are seldom required for routine service.
- Items marked "▲" are not stocked since they are seldom required for routine service. Some delay should be anticipated when ordering these items.
- Due to standardization, parts with part numbers (▲-▲▲▲-▲▲▲-XX or ▲-▲▲▲▲-▲▲▲-X) may be different from those used in the set.

CAPACITORS:

- All capacitors are in μF . Common capacitors are omitted. Refer to the following lists for their part numbers. MF: μF , PF: $\mu\mu\text{F}$.

RESISTORS

- All resistors are in ohms. Common 1/4W, 1/8W and 1/16W carbon resistors are omitted. Refer to the following lists for their part numbers.

- F : nonflammable

The components identified by shading and mark ▲ are critical for safety. Replace only with part number specified.

COILS

- MMH : mH, UH : μH

ELECTRICAL PARTS

Ref.No.	Part No.	Description
D901	▲.8-719-815-55	DIODE 1S1555
D902	▲.8-719-815-55	DIODE 1S1555
D903	▲.8-719-300-22	DIODE CTU-22U
D904	▲.8-719-300-22	DIODE CTU-22U
D905	▲.8-719-210-12	DIODE 10DF2
D906	▲.8-719-210-12	DIODE 10DF2
D907	▲.8-719-210-12	DIODE 10DF2
D908	▲.8-719-210-12	DIODE 10DF2
F2	▲.1-532-556-00	FUSE, TEMPERATURE
FL1	1-519-230-00	INDICATOR TUBE, FLUORESCENT
IC101	8-759-305-50	IC CX-550
IC105	8-759-305-50	IC CX-550
IC401	8-759-320-02	IC HA12002
IC701	8-759-131-41	IC UPD553C141
IC702	8-759-182-43	IC UPD8243C
IC703	8-759-611-00	IC CX-761A
IC704	8-759-984-69	IC MB84069B
IC705	8-759-985-01	IC MB84001B
IC706	8-759-100-67	IC UPA67C
IC801	8-759-890-00	IC CX-789
IC802	8-759-305-50	IC CX-550
IC803	8-759-700-00	IC CX-770
IC804	8-759-305-50	IC CX-550
J1	1-507-669-00	JACK
L101	1-407-519-00	INDUCTOR
L151	1-407-519-00	INDUCTOR
L501	▲;1-420-872-00	COIL, AIRE CORE
L551	▲;1-420-872-00	COIL, AIRE CORE
L901	▲.1-421-340-00	LINE FILTER
L902	▲.1-421-461-00	COIL, CHOKE
L903	▲.1-421-461-00	COIL, CHOKE
L904	▲.1-421-461-00	COIL, CHOKE
L905	▲.1-421-461-00	COIL, CHOKE
L906	▲.1-421-461-00	COIL, CHOKE
L907	▲.1-421-462-00	COIL, CHOKE
L908	▲.1-421-462-00	COIL, CHOKE
L909	▲.1-421-462-00	COIL, CHOKE
L910	▲.1-421-462-00	COIL, CHOKE
PL711	1-518-471-11	LAMP, PILOT
PL712	1-518-471-11	LAMP, PILOT
PL713	1-518-471-11	LAMP, PILOT
PL714	1-518-471-11	LAMP, PILOT
PL715	1-518-471-11	LAMP, PILOT
PL716	1-518-471-21	LAMP, PILOT

ELECTRICAL PARTS

Ref.No.	Part No.	Description
Q101	8-729-354-52	TRANSISTOR 2SC2545
Q102	8-729-354-52	TRANSISTOR 2SC2545
Q103	8-729-203-04	TRANSISTOR 2SK30A
Q151	8-729-354-52	TRANSISTOR 2SC2454
Q152	8-729-354-52	TRANSISTOR 2SC2454
Q153	8-729-203-04	TRANSISTOR 2SK30A
Q301	8-729-204-91	TRANSISTOR 2SA1049
Q302	8-729-679-82	TRANSISTOR 2SA798
Q303	8-729-629-12	TRANSISTOR 2SC2291
Q304	8-729-364-81	TRANSISTOR 2SB648
Q305	8-729-180-93	TRANSISTOR 2SD809
Q306	8-729-366-81	TRANSISTOR 2SD668
Q307	8-729-612-77	TRANSISTOR 2SA1027R
Q308	8-729-663-47	TRANSISTOR 2SC1364-7
Q309	8-729-663-47	TRANSISTOR 2SC1364-7
Q310	8-729-612-77	TRANSISTOR 2SA1027R
Q311	8-729-612-77	TRANSISTOR 2SA1027R
Q312	8-729-663-47	TRANSISTOR 2SC1364-7
Q313	8-729-306-92	TRANSISTOR 2SD669A
Q314	8-729-304-92	TRANSISTOR 2SB649A
Q315	8-729-168-11	TRANSISTOR 2SC2681
Q316	8-729-114-11	TRANSISTOR 2SA1141
Q317	8-729-117-54	TRANSISTOR 2SA1175
Q351	8-729-204-91	TRANSISTOR 2SA1049
Q352	8-729-679-82	TRANSISTOR 2SA798
Q353	8-729-629-12	TRANSISTOR 2SC2291
Q354	8-729-364-81	TRANSISTOR 2SB648
Q355	8-729-180-93	TRANSISTOR 2SD809
Q356	8-729-366-81	TRANSISTOR 2SD668
Q357	8-729-612-77	TRANSISTOR 2SA1027R
Q358	8-729-663-47	TRANSISTOR 2SC1364-7
Q359	8-729-663-47	TRANSISTOR 2SC1364-7
Q360	8-729-612-77	TRANSISTOR 2SA1027R
Q361	8-729-612-77	TRANSISTOR 2SA1027R
Q362	8-729-663-47	TRANSISTOR 2SC1364-7
Q363	8-729-306-92	TRANSISTOR 2SD669A
Q364	8-729-304-92	TRANSISTOR 2SB649A
Q365	8-729-168-11	TRANSISTOR 2SC2681
Q366	8-729-114-11	TRANSISTOR 2SA1141
Q367	8-729-117-54	TRANSISTOR 2SA1175
Q401	8-729-635-82	TRANSISTOR 2SD358
Q402	8-729-652-82	TRANSISTOR 2SB528
Q403	8-729-203-04	TRANSISTOR 2SK30A
Q404	8-729-203-04	TRANSISTOR 2SK30A
Q405	8-729-663-47	TRANSISTOR 2SC1364-7

NOTE:

- Items with no part number and no description are not stocked because they are seldom required for routine service.
- Items marked "▲" are not stocked since they are seldom required for routine service. Some delay should be anticipated when ordering these items.
- Due to standardization, parts with part numbers (▲-▲▲▲-▲▲▲-XX or ▲-▲▲▲-▲▲▲-X) may be different from those used in the set.

CAPACITORS:

- All capacitors are in μF . Common capacitors are omitted. Refer to the following lists for their part numbers.
MF: μF , PF: μmF .

RESISTORS

- All resistors are in ohms. Common 1/4W, 1/8W and 1/16W carbon resistors are omitted. Refer to the following lists for their part numbers.

- F : nonflammable

The components identified by shading and mark ▲ are critical for safety. Replace only with part number specified.

COILS

- MMH : mH, UH : μH

ELECTRICAL PARTS

Ref.No.	Part No.	Description
Q406	8-729-201-52	TRANSISTOR 2SA1015
Q407	8-729-663-47	TRANSISTOR 2SC1364-7
Q408	8-729-201-52	TRANSISTOR 2SA1015
Q601	8-729-635-82	TRANSISTOR 2SD358
Q602	8-729-103-43	TRANSISTOR 2SB734
Q603	8-729-364-72	TRANSISTOR 2SB647
Q604	8-729-652-82	TRANSISTOR 2SB528
Q701	8-729-201-52	TRANSISTOR 2SA1015
Q702	8-729-201-52	TRANSISTOR 2SA1015
Q703	8-729-663-47	TRANSISTOR 2SC1364-7
Q704	8-729-663-47	TRANSISTOR 2SC1364-7
Q705	8-729-663-47	TRANSISTOR 2SC1364-7
Q706	8-729-663-47	TRANSISTOR 2SC1364-7
Q707	8-729-663-47	TRANSISTOR 2SC1364-7
Q708	8-729-663-47	TRANSISTOR 2SC1364-7
Q709	8-729-201-52	TRANSISTOR 2SA1015
Q710	8-729-663-47	TRANSISTOR 2SC1364-7
Q711	8-729-201-52	TRANSISTOR 2SA1015
Q712	8-729-663-47	TRANSISTOR 2SC1364-7
Q713	8-729-663-47	TRANSISTOR 2SC1364-7
Q714	8-729-201-52	TRANSISTOR 2SC1015
Q715	8-729-663-47	TRANSISTOR 2SC1364-7
Q716	8-729-663-47	TRANSISTOR 2SC1364-7
Q717	8-729-663-47	TRANSISTOR 2SC1364-7
Q901	8-729-612-77	TRANSISTOR 2SA1027R
Q902	8-729-663-47	TRANSISTOR 2SC1364-7
Q903	X-4866-605-1	TRANSISTOR ASSY, SERVICE 2SC2656
Q904	X-4866-605-1	TRANSISTOR ASSY, SERVICE 2SC2656
R000	1-205-599-00	CEMENT-COATED 75 10% 5W
R315	1-247-091-00	CARBON 22 5% 1/4W F
R316	1-247-091-00	CARBON 22 5% 1/4W F
R319	1-247-107-00	CARBON 100 5% 1/4W F
R320	1-247-107-00	CARBON 100 5% 1/4W F
R321	1-247-107-00	CARBON 100 5% 1/4W F
R322	1-247-107-00	CARBON 100 5% 1/4W F
R333	1-247-228-00	CARBON 330 5% 1/2W F
R334	1-217-611-00	RES, METAL PLATE 0.1
R335	1-217-611-00	RES, METAL PLATE 0.1
R336	1-217-611-00	RES, METAL PLATE 0.1
R365	1-247-091-00	CARBON 22 5% 1/4W F
R366	1-247-091-00	CARBON 22 5% 1/4W F
R369	1-247-107-00	CARBON 100 5% 1/4W F
R370	1-247-107-00	CARBON 100 5% 1/4W F
R371	1-247-107-00	CARBON 100 5% 1/4W F
R372	1-247-107-00	CARBON 100 5% 1/4W F
R383	1-247-228-00	CARBON 330 5% 1/2W F

ELECTRICAL PARTS

Ref.No.	Part No.	Description
R384	1-217-611-00	RES, METAL PLATE 0.1
R385	1-217-611-00	RES, METAL PLATE 0.1
R386	1-217-611-00	RES, METAL PLATE 0.1
R401	1-213-137-00	METAL 330 5% 1W F
R402	1-213-137-00	METAL 330 5% 1W F
R418	1-206-672-00	METAL 2.2K 5% 2W F
R421	1-244-881-00	CARBON 2.2K 5% 1/2W
R502	1-213-139-00	METAL 470 5% 1W F
R552	1-213-139-00	METAL 470 5% 1W F
R601	1-247-079-00	CARBON 4.7 5% 1/4W F
R602	1-247-079-00	CARBON 4.7 5% 1/4W F
R606	1-247-079-00	CARBON 4.7 5% 1/4W F
R901	1-244-928-00	CARBON 200K 5% 1/2W
R902	1-246-483-15	CARBON 2.7K 5% 1/4W
R903	1-246-507-15	CARBON 27K 5% 1/4W
R904	1-246-483-15	CARBON 2.7K 5% 1/4W
R905	1-246-469-15	CARBON 680 5% 1/4W
R906	1-244-833-00	CARBON 22 5% 1/2W
RT301	1-226-232-00	RES, ADJ, CARBON 500
RT302	1-226-232-00	RES, ADJ, CARBON 500
RT351	1-226-232-00	RES, ADJ, CARBON 500
RT352	1-226-232-00	RES, ADJ, CARBON 500
RY301	1-515-347-00	RELAY
RY401	1-515-348-00	RELAY
S1	1-553-780-00	SWITCH, SLDE (REMOTE)
S2	1-553-778-00	SWITCH, PUSH (2 KEY)
S3	1-553-778-00	SWITCH, PUSH (2 KEY)
S5	1-552-539-00	SWITCH, KEY BOARD
S6	1-552-539-00	SWITCH, KEY BOARD
S7	1-552-539-00	SWITCH, KEY BOARD
S8	1-552-539-00	SWITCH, KEY BOARD
S9	1-552-539-00	SWITCH, KEY BOARD
S10	1-552-539-00	SWITCH, KEY BOARD
S11	1-552-539-00	SWITCH, KEY BOARD
S12	1-552-539-00	SWITCH, KEY BOARD
S13	1-552-539-00	SWITCH, KEY BOARD
S14	1-552-539-00	SWITCH, KEY BOARD
S15	1-552-539-00	SWITCH, KEY BOARD
S16	1-552-539-00	SWITCH, KEY BOARD
S17	1-552-539-00	SWITCH, KEY BOARD
T901	1-543-100-00	CORE
T902	1-543-166-00	CORE
T903	1-447-034-00	TRANSFORMER, CONVERTER
X701	1-527-522-00	RADIATOR, CERAMIC

NOTE:

- Items with no part number and no description are not stocked because they are seldom required for routine service.
- Items marked "▲" are not stocked since they are seldom required for routine service. Some delay should be anticipated when ordering these items.
- Due to standardization, parts with part numbers (▲-▲▲▲-▲▲▲-XX or ▲-▲▲▲-▲▲▲-X) may be different from those used in the set.

CAPACITORS:

- All capacitors are in μF . Common capacitors are omitted. Refer to the following lists for their part numbers. MF: μF , PF: μF .

RESISTORS

- All resistors are in ohms. Common 1/4W, 1/8W and 1/16W carbon resistors are omitted. Refer to the following lists for their part numbers.

- F: nonflammable

The components identified by shading and mark ▲ are critical for safety. Replace only with part number specified.

COILS

- MMH: mH, UH: μH

ELECTROLYTIC CAPACITORS

CAP. (μF)	RATING → : Use the high voltage rated one.					
	6.3 VOLT.	10 VOLT.	16 VOLT.	25 VOLT.	35 VOLT.	50 VOLT.
	PART No.	PART No.	PART No.	PART No.	PART No.	PART No.
0.47						
1.0					→	1-121-726-00
2.2					→	1-121-391-00
3.3					→	1-121-450-00
4.7	→	→	→	1-121-392-00	→	1-121-393-00
10	→	→	→	1-121-395-00	→	1-121-396-00
22	→	→	1-121-651-00	1-121-398-00	→	1-121-738-00
33	→	→	1-121-479-00	1-121-480-00	1-121-662-00	1-121-152-00
47	→	→	1-121-403-00	1-121-404-00	1-121-652-00	1-121-405-00
100	→	1-121-352-00	1-121-409-00	1-121-410-00	1-121-653-00	1-121-411-00
220	1-121-417-00	1-121-414-00	1-121-415-00	1-121-416-00	1-121-357-00	1-121-417-00
330	1-121-417-00	1-121-420-00	1-121-421-00	1-121-422-00	1-121-261-00	1-121-423-00
470	1-121-751-00	1-121-805-00	1-121-521-00	1-121-654-00	1-121-655-00	1-121-656-00
1000	1-121-424-00	1-121-425-00	1-121-426-00	1-121-733-00	1-121-361-00	1-121-810-00
2200	→	1-121-736-00	1-121-245-00	1-121-657-00	1-121-388-00	1-123-061-00
3300	1-121-658-00	1-121-659-00	1-121-660-00	1-123-067-00	1-121-984-00	→
	1-121-661-00	1-123-075-00	1-123-071-00	→	→	→

CAP. (μF)	100 VOLT.	160 VOLT.	250 VOLT.	350 VOLT.
	PART No.	PART No.	PART No.	PART No.
0.47	→	→	→	→
1.0	1-123-249-00	1-123-252-00	1-123-003-00	1-121-168-00
2.2	1-123-250-00	1-123-026-00	→	1-123-028-00
3.3	1-121-995-00	→	1-123-004-00	1-123-006-00
4.7	1-123-255-00	1-121-246-00	1-121-759-00	1-123-007-00
10	1-121-126-00	1-121-999-00	1-123-254-00	1-123-008-00
22	1-121-996-00	1-123-253-00	1-123-005-00	1-123-022-00
33	1-121-997-00	1-121-757-00	→	→
47	1-123-251-00	1-121-919-00	→	→
100	1-123-084-00	→	→	→

CERAMIC CAPACITORS

CAP. (pF)	RATING						
	50 VOLT.	CAP. (pF)	50 VOLT.	CAP. (pF)	50 VOLT.	CAP. (μF)	50 VOLT.
	PART No.		PART No.		PART No.		PART No.
0.5	1-101-837-00	22	1-102-959-00	150	1-101-361-00	0.001	1-102-074-00
0.75	1-101-586-00	24	1-102-960-00	160	1-101-367-00	0.0012	1-102-118-00
1.0	1-102-934-00	27	1-102-961-00	180	1-103-976-00	0.0015	1-102-119-00
1.5	1-101-576-00	30	1-102-962-00	200	1-102-977-00	0.0018	1-102-120-00
2.0	1-102-935-00	33	1-102-963-00	220	1-102-978-00	0.0022	1-102-121-00
3	1-102-936-00	36	1-102-964-00	240	1-102-979-00	0.0027	1-102-122-00
4	1-102-937-00	39	1-102-965-00	270	1-102-980-00	0.0033	1-102-123-00
5	1-102-942-00	43	1-102-966-00	300	1-102-981-00	0.0039	1-102-124-00
6	1-102-943-00	47	1-101-880-00	330	1-102-820-00	0.0047	1-102-125-00
7	1-102-944-00	51	1-101-882-00	360	1-102-821-00	0.0056	1-102-126-00
8	1-102-945-00	56	1-101-884-00	390	1-102-822-00	0.0068	1-102-127-00
9	1-102-946-00	62	1-101-886-00	430	1-102-823-00	0.0082	1-102-128-00
10	1-102-947-00	68	1-101-888-00	470	1-102-824-00	0.01	1-102-129-00
11	1-102-948-00	75	1-101-890-00	510	1-101-059-00	0.022	1-101-005-00
12	1-102-949-00	82	1-102-971-00	560	1-102-115-00	0.047	1-101-006-00
13	1-102-950-00	91	1-102-972-00	680	1-102-116-00		
15	1-102-951-00	100	1-102-973-00	820	1-102-117-00		
16	1-102-952-00	110	1-102-815-00				
18	1-102-953-00	120	1-102-816-00				
20	1-102-958-00	130	1-101-081-00				

0.001μF = 1,000pF

CERAMIC (SEMICONDUCTOR) CAPACITORS

CAP. (μF)	RATING → : Use the high voltage rated one.				
	25 VOLT.	50 VOLT.	CAP. (μF)	25 VOLT.	50 VOLT.
	PART No.	PART No.		PART No.	PART No.
0.001	→	1-161-039-00	0.018	1-161-016-00	1-161-054-00
0.0012	→	1-161-040-00	0.022	1-161-017-00	1-161-055-00
0.0015	→	1-161-041-00	0.027	1-161-018-00	1-161-056-00
0.0018	→	1-161-042-00	0.033	1-161-019-00	1-161-057-00
0.0022	→	1-161-043-00	0.039	1-161-010-00	1-161-058-00
0.0027	→	1-161-044-00	0.047	1-161-021-00	1-161-059-00
0.0033	→	1-161-045-00	0.056	→	1-161-060-00
0.0039	→	1-161-046-00	0.068	→	1-161-061-00
0.0047	→	1-161-047-00	0.082	1-161-024-00	1-161-062-00
0.0056	→	1-161-048-00	0.1	1-161-025-00	1-161-063-00
0.0068	→	1-161-049-00			
0.0082	1-161-012-00	1-161-050-00			
0.01	1-161-013-00	1-161-051-00			
0.012	→	1-161-052-00			
0.015	1-161-015-00	1-161-053-00			

MYLAR CAPACITORS

CAP. (μF)	RATING																		
	50 VOLT.			100 VOLT.			200 VOLT.			CAP. (μF)	50 VOLT.			100 VOLT.			200 VOLT.		
	PART No.	PART No.	PART No.	PART No.	PART No.	PART No.	PART No.	PART No.	PART No.		PART No.	PART No.	PART No.	PART No.	PART No.	PART No.			
0.001	1-108-227-00	1-108-365-00	1-108-409-00	0.01	1-108-239-00	1-108-377-00	1-108-421-00	0.1	1-108-251-00	1-108-389-00	1-108-433-00								
0.0012	1-108-351-00	1-108-366-00	1-108-410-00	0.012	1-108-357-00	1-108-378-00	1-108-422-00	0.12	1-108-363-00	1-108-390-00	1-108-434-00								
0.0015	1-108-228-00	1-108-367-00	1-108-411-00	0.015	1-108-240-00	1-108-379-00	1-108-423-00	0.15	1-108-252-00	1-108-391-00	1-108-435-00								
0.0018	1-108-352-00	1-108-368-00	1-108-412-00	0.018	1-108-358-00	1-108-380-00	1-108-424-00	0.18	1-108-364-00	1-108-392-00	1-108-436-00								
0.0022	1-108-230-00	1-108-369-00	1-108-413-00	0.022	1-108-242-00	1-108-381-00	1-108-425-00	0.22	1-108-254-00	1-108-393-00	1-108-437-00								
0.0027	1-108-353-00	1-108-370-00	1-108-414-00	0.027	1-108-359-00	1-108-382-00	1-108-426-00	0.27	1-108-854-00	-	-								
0.0033	1-108-232-00	1-108-371-00	1-108-415-00	0.033	1-108-244-00	1-108-383-00	1-108-427-00	0.33	1-108-855-00	-	-								
0.0039	1-108-354-00	1-108-372-00	1-108-416-00	0.039	1-108-360-00	1-108-384-00	1-108-428-00	0.39	1-108-856-00	-	-								
0.0047	1-108-234-00	1-108-373-00	1-108-417-00	0.047	1-108-246-00	1-108-385-00	1-108-429-00	0.47	1-108-857-00	-	-								
0.0056	1-108-355-00	1-108-374-00	1-108-418-00	0.056	1-108-361-00	1-108-386-00	1-108-430-00	-	-	-	-								
0.0068	1-108-237-00	1-108-375-00	1-108-419-00	0.068	1-108-249-00	1-108-387-00	1-108-431-00	-	-	-	-								
0.0082	1-108-356-00	1-108-376-00	1-108-420-00	0.082	1-108-362-00	1-108-388-00	1-108-432-00	-	-	-	-								



TANTALUM CAPACITORS

CAP. (μF)	RATING							→ : Use the high voltage rated one.							
	3.15 VOLT.		6.3 VOLT.		10 VOLT.		16 VOLT.		20 VOLT.		25 VOLT.		35 VOLT.		
	PART No.	PART No.	PART No.	PART No.	PART No.	PART No.	PART No.		PART No.	PART No.	PART No.	PART No.	PART No.	PART No.	PART No.
0.01	-	-	-	-	-	-	-	-	-	-	-	-	-	1-131-396-00	
0.015	-	-	-	-	-	-	-	-	-	-	-	-	-	1-131-397-00	
0.022	-	-	-	-	-	-	-	-	-	-	-	-	-	1-131-398-00	
0.033	-	-	-	-	-	-	-	-	-	-	-	-	-	1-131-399-00	
0.047	-	-	-	-	-	-	-	-	-	-	-	-	-	1-131-400-00	
0.068	-	-	-	-	-	-	-	-	-	-	-	-	-	1-131-401-00	
0.1	-	-	-	-	-	-	-	-	-	-	-	-	-	1-131-402-00	
0.15	-	-	-	-	-	-	-	-	-	-	-	-	-	1-131-403-00	
0.22	-	-	-	-	-	-	-	-	-	-	-	-	-	1-131-404-00	
0.33	-	-	-	-	-	-	-	-	-	-	-	-	-	1-131-405-00	
0.47	-	-	-	-	-	-	-	-	-	-	-	-	-	1-131-406-00	
0.68	-	-	-	-	-	-	-	-	-	-	-	-	-	1-131-407-00	
1.0	-	-	-	-	-	-	-	-	-	-	-	-	-	1-131-408-00	
1.5	-	-	-	-	-	-	-	-	-	-	-	-	-	1-131-348-00	
2.2	-	-	-	-	-	-	-	-	-	-	-	-	-	1-131-349-00	
3.3	-	-	-	-	-	-	-	-	-	-	-	-	-	1-131-350-00	
4.7	-	-	-	-	-	-	-	-	-	-	-	-	-	1-131-351-00	
6.8	-	-	-	-	-	-	-	-	-	-	-	-	-	1-131-352-00	
10	-	-	-	-	-	-	-	-	-	-	-	-	-	1-131-353-00	
15	-	-	-	-	-	-	-	-	-	-	-	-	-	-	
22	-	-	-	-	-	-	-	-	-	-	-	-	-	-	
33	-	-	-	-	-	-	-	-	-	-	-	-	-	-	
47	-	-	-	-	-	-	-	-	-	-	-	-	-	-	
68	-	-	-	-	-	-	-	-	-	-	-	-	-	-	
100	-	-	-	-	-	-	-	-	-	-	-	-	-	-	



TANTALUM CAPACITORS

CAP. (μF)	RATING											
	3 VOLT.		6.3 VOLT.		10 VOLT.		16 VOLT.		20 VOLT.		35 VOLT.	
	PART No.	PART No.	PART No.	PART No.	PART No.	PART No.	PART No.	PART No.	PART No.	PART No.	PART No.	
0.033	-	-	-	-	-	-	-	-	-	-	-	1-131-273-00
0.047	-	-	-	-	-	-	-	-	-	-	-	1-131-274-00
0.068	-	-	-	-	-	-	-	-	-	-	-	1-131-275-00
0.1	-	-	-	-	-	-	-	-	-	-	-	1-131-276-00
0.15	-	-	-	-	-	-	-	-	-	-	-	1-131-277-00
0.22	-	-	-	-	-	-	-	-	-	-	-	1-131-278-00
0.33	-	-	-	-	-	-	-	-	-	-	-	1-131-279-00
0.47	-	-	-	-	-	-	-	-	-	-	-	1-131-280-00
0.68	-	-	-	-	-	-	-	-	-	-	-	1-131-281-00
1.0	-	-	-	-	-	-	-	-	-	-	-	1-131-282-00
1.5	-	-	-	-	-	-	-	-	-	-	-	1-131-283-00
2.2	-	-	-	-	-	-	-	-	-	-	-	1-131-284-00
3.3	-	-	-	-	-	-	-	-	-	-	-	-
4.7	-	-	-	-	-	-	-	-	-	-	-	-
6.8	-	-	-	-	-	-	-	-	-	-	-	-
10	-	-	-	-	-	-	-	-	-	-	-	-
15	-	-	-	-	-	-	-	-	-	-	-	-
22	-	-	-	-	-	-	-	-	-	-	-	-
33	-	-	-	-	-	-	-	-	-	-	-	-
47	-	-	-	-	-	-	-	-	-	-	-	-
100	-	-	-	-	-	-	-	-	-	-	-	-

1/4 WATT CARBON RESISTORS

Ω	Part No.	Ω	Part No.	Ω	Part No.	Ω	Part No.	Ω	Part No.	Ω	Part No.	Ω	Part No.
1.0	1-246-401-00	10	1-246-425-00	100	1-246-449-00	1.0k	1-246-473-00	10k	1-246-497-00	100k	1-246-521-00	1.0M	1-246-545-00
1.1	1-246-402-00	11	1-246-426-00	110	1-246-450-00	1.1k	1-246-474-00	11k	1-246-498-00	110k	1-246-522-00	1.1M	1-210-814-00
1.2	1-246-403-00	12	1-246-427-00	120	1-246-451-00	1.2k	1-246-475-00	12k	1-246-499-00	120k	1-246-523-00	1.2M	1-210-815-00
1.3	1-246-404-00	13	1-246-428-00	130	1-246-452-00	1.3k	1-246-476-00	13k	1-246-500-00	130k	1-246-524-00	1.3M	1-210-816-00
1.5	1-246-405-00	15	1-246-429-00	150	1-246-453-00	1.5k	1-246-477-00	15k	1-246-501-00	150k	1-246-525-00	1.5M	1-210-817-00
1.6	1-246-406-00	16	1-246-430-00	160	1-246-454-00	1.6k	1-246-478-00	16k	1-246-502-00	160k	1-246-526-00	1.6M	1-210-818-00
1.8	1-246-407-00	18	1-246-431-00	180	1-246-455-00	1.8k	1-246-479-00	18k	1-246-503-00	180k	1-246-527-00	1.8M	1-210-819-00
2.0	1-246-408-00	20	1-246-432-00	200	1-246-456-00	2.0k	1-246-480-00	20k	1-246-504-00	200k	1-246-528-00	2.0M	1-210-820-00
2.2	1-246-409-00	22	1-246-433-00	220	1-246-457-00	2.2k	1-246-481-00	22k	1-246-505-00	220k	1-246-529-00	2.2M	1-210-821-00
2.4	1-246-410-00	24	1-246-434-00	240	1-246-458-00	2.4k	1-246-482-00	24k	1-246-506-00	240k	1-246-530-00	2.4M	1-244-754-00
2.7	1-246-411-00	27	1-246-435-00	270	1-246-459-00	2.7k	1-246-483-00	27k	1-246-507-00	270k	1-246-531-00	2.7M	1-244-755-00
3.0	1-246-412-00	30	1-246-436-00	300	1-246-460-00	3.0k	1-246-484-00	30k	1-246-508-00	300k	1-246-532-00	3.0M	1-244-756-00
3.3	1-246-413-00	33	1-246-437-00	330	1-246-461-00	3.3k	1-246-485-00	33k	1-246-509-00	330k	1-246-533-00	3.3M	1-244-757-00
3.6	1-246-414-00	36	1-246-438-00	360	1-246-462-00	3.6k	1-246-486-00	36k	1-246-510-00	360k	1-246-534-00	3.6M	1-244-758-00
3.9	1-246-415-00	39	1-246-439-00	390	1-246-463-00	3.9k	1-246-487-00	39k	1-246-511-00	390k	1-246-535-00	3.9M	1-244-759-00
4.3	1-246-416-00	43	1-246-440-00	430	1-246-464-00	4.3k	1-246-488-00	43k	1-246-512-00	430k	1-246-536-00	4.3M	1-244-760-00
4.7	1-246-417-00	47	1-246-441-00	470	1-246-465-00	4.7k	1-246-489-00	47k	1-246-513-00	470k	1-246-537-00	4.7M	1-244-761-00
5.1	1-246-418-00	51	1-246-442-00	510	1-246-466-00	5.1k	1-246-490-00	51k	1-246-514-00	510k	1-246-538-00	5.1M	1-244-762-00
5.6	1-246-419-00	56	1-246-443-00	560	1-246-467-00	5.6k	1-246-491-00	56k	1-246-515-00	560k	1-246-539-00		
6.2	1-246-420-00	62	1-246-444-00	620	1-246-468-00	6.2k	1-246-492-00	62k	1-246-516-00	620k	1-246-540-00		
6.8	1-246-421-00	68	1-246-445-00	680	1-246-469-00	6.8k	1-246-493-00	68k	1-246-517-00	680k	1-246-541-00		
7.5	1-246-422-00	75	1-246-446-00	750	1-246-470-00	7.5k	1-246-494-00	75k	1-246-518-00	750k	1-246-542-00		
8.2	1-246-423-00	82	1-246-447-00	820	1-246-471-00	8.2k	1-246-495-00	82k	1-246-519-00	820k	1-246-543-00		
9.1	1-246-424-00	91	1-246-448-00	910	1-246-472-00	9.1k	1-246-496-00	91k	1-246-520-00	910k	1-246-544-00		

HARDWARE NOMENCLATURE

Screw:

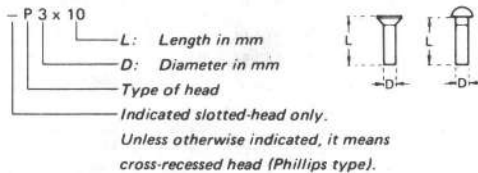

Nut, Washer, Retaining ring:

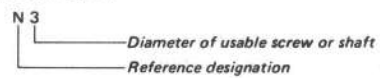

Reference Designation	Shape	Description	Remarks
SCREWS			
P		pan-head screw	binding-head (B) screw for replacement
PWH		pan-head screw with washer face	binding-head (B) screw and flat washer for replacement
PS PSP		pan-head screw with spring washer	binding-head (B) screw and spring washer for replacement
PSW PSPW		pan-head screw with spring and flat washers	binding-head (B) screw and spring and flat washers for replacement
R		round-head screw	binding-head (B) screw for replacement
K		flat-countersunk-head screw	
RK		oval-countersunk-head screw	
B		binding-head screw	
T		truss-head screw	binding-head (B) screw for replacement
F		flat-fillister-head screw	
RF		fillister-head screw	
BV		brazer-head screw	

Reference Designation	Shape	Description	Remarks
SELF-TAPPING SCREWS			
TA		self-tapping screw	ex: TA, P 3 x 10
PTP		pan-head self-tapping screw	binding-head self-tapping (TA, B) screw for replacement
PTPWH		pan-head self-tapping screw with washer face	binding-head self-tapping (TA, B) screw and flat washer for replacement
PTTWH		pan-head thread-rolling screw with washer face	binding-head (B) screw and flat washer for replacement
SET SCREWS			
SC		set screw	
SC		hexagon-socket set screw	ex: SC 2.6 x 4, hexagon socket
NUT			
N		nut	
WASHERS			
W		flat washer	
SW		spring washer	
LW		internal-tooth lock washer	ex: LW3, internal
LW		external-tooth lock washer	ex: LW3, external
RETAINING RINGS			
E		retaining ring	
G		grip-type retaining ring	

Sony Corporation

© 1981