

# ICF-C793/C793L

## SERVICE MANUAL

Ver 1.0 1999.02



Photo: ICF-C793L

*US Model*  
*Canadian Model*  
*Australian Model*  
ICF-C793  
*AEP Model*  
ICF-C793/C793L  
*UK Model*  
ICF-C793L

### SPECIFICATIONS

#### Time display

UK, Australia, North and South America	12 hour
Other countries	24 hour

#### Frequency range

Model for North and South America		
Band	ICF-C793	Channel step
FM	87.5-108 MHz	0.1 MHz
AM	530-1,710 kHz	10 kHz

#### Model for other countries

Band	ICF-C793	ICF-C793L	Channel step
FM	87.5-108 MHz	87.5-108 MHz	0.05 MHz*
AM(MW)	531-1,602 kHz	531-1,602 kHz	9 kHz
LW	—	153 - 279 kHz	9 kHz

\* The frequency shown in the display changes in steps of 0.1 MHz.  
(Example: Frequency 88.05 MHz appears as "88.0 MHz".)

#### Speaker

Approx. 6.6 cm (2 5/8 in) dia.

#### Power output

150 mW (at 10% harmonic distortion)

#### Power requirements

North and South American model: 120 V AC,  
60 Hz  
Other models: 220-230 V AC, 50 Hz

#### Dimensions

Approx. 113 x 147.5 x 104.5 mm (w/h/d)  
(4 1/2 x 5 7/8 x 4 1/8 in) incl. projecting  
parts and controls

#### Mass

Approx. 730g (1 lb 10 oz)  
ICF-C793L (UK model)  
Approx. 780 g (1 lb 12 oz)

Design and specifications are subject to change  
without notice.

ICF-C793

FM/AM PLL SYNTHESIZED CLOCK RADIO

ICF-C793L

FM/MW/LW PLL SYNTHESIZED CLOCK RADIO



# SONY®

## TABLE OF CONTENTS

<b>1. GENERAL</b> .....	3
<b>2. DISASSEMBLY</b> .....	5
<b>3. ELECTRICAL ADJUSTMENTS</b> .....	6
<b>4. DIAGRAMS</b>	
4-1. Block Diagram .....	9
4-2. Printed Wiring Boards .....	11
4-3. Schematic Diagram .....	13
4-4. IC Pin Function Description .....	16
<b>5. EXPLODED VIEWS</b> .....	17
<b>6. ELECTRICAL PARTS LIST</b> .....	19

## SAFETY CHECK-OUT

After correcting the original service problem, perform the following safety check before releasing the set to the customer: Check the antenna terminals, metal trim, "metallized" knobs, screws, and all other exposed metal parts for AC leakage. Check leakage as described below.

## LEAKAGE TEST

The AC leakage from any exposed metal part to earth ground and from all exposed metal parts to any exposed metal part having a return to chassis, must not exceed 0.5 mA (500 microampers.). Leakage current can be measured by any one of three methods.

1. A commercial leakage tester, such as the Simpson 229 or RCA WT-540A. Follow the manufacturers' instructions to use these instruments.
2. A battery-operated AC milliammeter. The Data Precision 245 digital multimeter is suitable for this job.
3. Measuring the voltage drop across a resistor by means of a VOM or battery-operated AC voltmeter. The "limit" indication is 0.75 V, so analog meters must have an accurate low-voltage scale. The Simpson 250 and Sanwa SH-63Trd are examples of a passive VOM that is suitable. Nearly all battery operated digital multimeters that have a 2 V AC range are suitable. (See Fig. A)

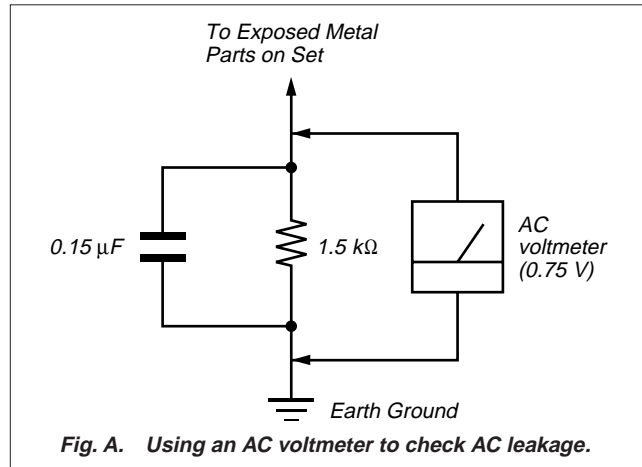

## Notes on chip component replacement

- Never reuse a disconnected chip component.
- Notice that the minus side of a tantalum capacitor may be damaged by heat.

## SAFETY-RELATED COMPONENT WARNING!!

COMPONENTS IDENTIFIED BY MARK  $\triangle$  OR DOTTED LINE WITH MARK  $\triangle$  ON THE SCHEMATIC DIAGRAMS AND IN THE PARTS LIST ARE CRITICAL TO SAFE OPERATION. REPLACE THESE COMPONENTS WITH SONY PARTS WHOSE PART NUMBERS APPEAR AS SHOWN IN THIS MANUAL OR IN SUPPLEMENTS PUBLISHED BY SONY.

## ATTENTION AU COMPOSANT AYANT RAPPORT À LA SÉCURITÉ!

LES COMPOSANTS IDENTIFIÉS PAR UNE MARQUE  $\triangle$  SUR LES DIAGRAMMES SCHÉMATIQUES ET LA LISTE DES PIÈCES SONT CRITIQUES POUR LA SÉCURITÉ DE FONCTIONNEMENT. NE REMPLACER CES COMPOSANTS QUE PAR DES PIÈCES SONY DONT LES NUMÉROS SONT DONNÉS DANS CE MANUEL OU DANS LES SUPPLÉMENTS PUBLIÉS PAR SONY.

## HOW TO CHANGED THE CERAMIC FILTERS

This model is used two ceramic filters of CF2 and CF3. You must used same type of color marked ceramic filters in order to meet same specifications. Therefore, the ceramic filter must changed two pieces together since it's supply two pieces in one package as a spare parts.

Mark	Center frequency
red	10.70 MHz
blue	10.67 MHz
orange	10.73 MHz
black	10.64 MHz
white	10.76 MHz

## SECTION 1 GENERAL

This section is extracted from instruction manual.

### LOCATION OF CONTROLS

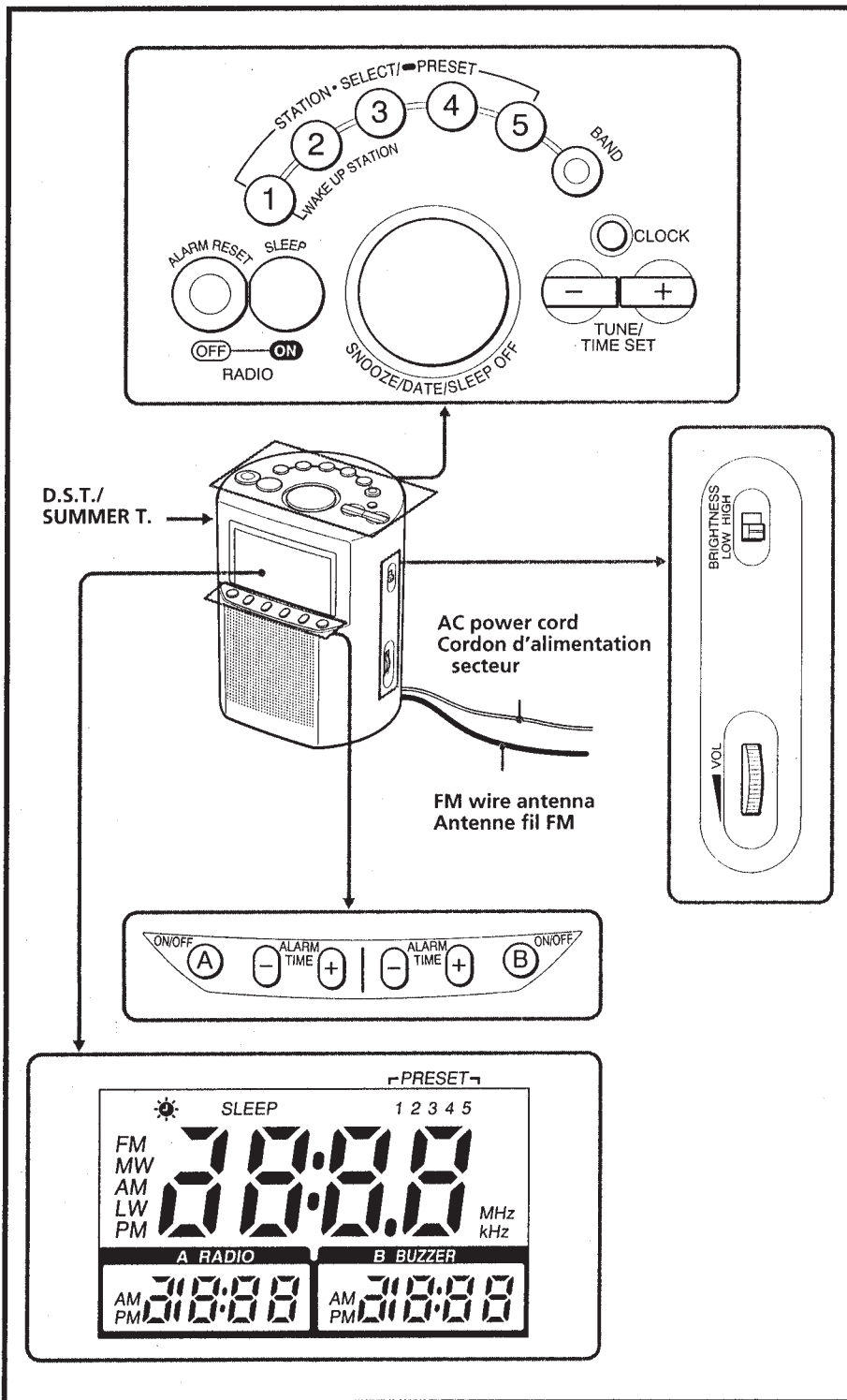

### Before You Begin

Thank you for choosing the Sony Dream Machine. The Dream Machine will give you many hours of reliable service and listening pleasure.

Before operating your unit, please read these instructions thoroughly and retain them for future reference.

The instructions here are for models ICF-C793 and ICF-C793L.

Their difference is shown below:

Model Number	ICF-C793	ICF-C793L
Band	FM/AM	FM/MW/LW

### Features

- Dual alarm FM/AM (ICF-C793) or FM/MW/LW (ICF-C793L) PLL (phase locked loop) synthesized clock radio.
- Triple display—main display, and two sub-displays for the alarms.
- LCD with backlight, and brightness adjustment for the backlight.
- Date button to display the year, month and date.
- Easy radio preset—with the pressing of a button.
- D.S.T. (Daylight Saving Time)—Summer time adjustment (one-hour skip function).
- 5 random station presets.
- Radio and buzzer alarms, as well as a snooze function.
- Self-powered backup that enables the current time and memory to be stored for about 30 minutes without batteries when the power supply is interrupted.

### Setting the Clock

- 1 Plug in the clock radio.  
The display will flash "AM 12:00" or "0:00".
- 2 Press **CLOCK** for a few seconds.  
You will hear a beep and the year will start to flash in the display.
- 3 Press **TUNE/TIME SET +** or **-** until the correct year appears in the display.
- 4 Press **CLOCK** once.
- 5 Repeat steps 3 and 4 to set the month, date, hour, and minute.  
After setting the minute, press **CLOCK** to start the counting of the seconds.

- To display the year and date, press **SNOOZE/DATE/SLEEP OFF** once for the date, and within 2 seconds press it again for the year. The display shows the date or year for a few seconds and then changes back to the current time.
- To set the current time rapidly, hold down the **+** or **-** button.
- The clock system varies depending on the model you own.  
12-hour system: "AM 12:00" = midnight  
24-hour system: "0:00" = midnight
- In step 5, when you press **CLOCK** after the minute setting to activate the clock, the seconds start counting from zero.

### To change the display to the daylight saving time (summer time) indication

Press **D.S.T./SUMMER T.**

"\*" is displayed and the time indication changes to summer time.

To deactivate the summer time function, press **D.S.T./SUMMER T.** again.

## Operating the Radio

### Manual Tuning

- 1 Press **RADIO ON** to turn on the radio. The display shows the band and frequency for a few seconds and then changes back to the current time.
- 2 Press **BAND** repeatedly to select the desired band.
- 3 Use **TUNE/TIME SET +** or **-** to tune in to the desired station.
- 4 Adjust volume using **VOL**.

- To turn off the radio, press **RADIO OFF**.
- To improve reception

**FM:** Extend the FM wire antenna fully to increase reception sensitivity.

**AM(MW)/LW:** Rotate the unit horizontally for optimum reception. A ferrite bar is built in to the unit. Do not operate the unit over a steel desk or metal surface, as this may lead to interference of reception.

- To check the station being received, press the **TUNE/TIME SET +** or **-** button lightly. The display shows the band and frequency for a few seconds and then changes back to the current time.
- If the radio alarm comes on while the radio is on, the unit switches to the station on preset button 1 (the **WAKE UP STATION**).

### To set the brightness of the backlight

Set **BRIGHTNESS** for the display to **H** (high) or **L** (low) according to your preference.

## Preset Tuning

You can preset up to five stations for one-touch tuning; one for each of the preset buttons 1 to 5.

### Presetting a station

Example: To preset AM 1260 kHz onto preset button 2.

- 1 Press **RADIO ON** to turn on the radio.
- 2 Tune in to the station you want to preset. (See "Manual Tuning".)
- 3 Hold down the desired **STATION•SELECT/PRESET** button (in this case, **2**) until you hear two short beeps.



The display shows the frequency for a few seconds and then changes back to the current time.

For the radio alarm, preset the station to be used as the alarm onto preset button 1.

### To change a preset station

Tune in manually to the station you want to store and hold down the preset button until you hear two short beeps. The previously stored station will be replaced by the new one.

### Tuning in to a preset station

- 1 Press **RADIO ON** to turn on the radio.
- 2 Press the **STATION•SELECT/PRESET** button where the desired station is stored.
- 3 Adjust volume using **VOL**. After a few seconds, the display will return to the current time but the preset button number will remain.

## Setting the Alarm

Before setting the time for the radio and buzzer alarms, make sure you have set the current time (See "Setting the Clock"). For the radio alarm, make sure you have preset a radio station onto preset button 1 (See "Preset Tuning").

### To Set the Alarm Time

Press and hold down the **ALARM TIME +** or **-** button located directly under the **A RADIO** or **B BUZZER** display until the desired time appears.

## ALARM ON—

### To Activate the Alarm

#### For the radio alarm:

Press the **ON/OFF A** button located directly under the **A RADIO** display. The **A RADIO** display lights up and shows the alarm time you have set.

#### For the buzzer alarm:

Press the **ON/OFF B** button located directly under the **B BUZZER** display. The **B BUZZER** display lights up and shows the alarm time you have set.

At the time set, the radio or buzzer alarm will sound for 60 minutes or until turned off.

#### Notes

- When the alarm comes on at the preset time, the alarm time in the display flashes.
- When the **ALARM TIME +** or **-** button is held down, the displayed time initially changes in one-minute steps, and after a few seconds, switches to five-minute steps.
- If you do not preset the radio/buzzer alarm time and activate the alarm, the alarm will sound at AM 12:00 or 0:00.
- For the buzzer alarm, the beeping of the alarm becomes more rapid after every few seconds in five progressive stages.

## ALARM OFF—

### To Stop the Alarm

Press **ALARM RESET** to turn off the alarm.

The alarm will come on again at the same time the next day.

### To Cancel the Alarm

For the radio alarm, press the **ON/OFF A** button to switch off the display.

For the buzzer alarm, press the **ON/OFF B** button to switch off the display.

#### Notes

- The alarm does not function unless you set the clock and activate the **A RADIO** or **B BUZZER** function.
- If both the radio and buzzer alarms are set for the same time, the radio alarm takes precedence.

## To Doze for a Few More Minutes

Press **SNOOZE/DATE/SLEEP OFF**.

The radio or buzzer turns off but will automatically come on again after about 8 minutes. You can repeat this process as many times as you like.

## Setting the Sleep Timer

You can enjoy falling asleep to the radio using the built-in sleep timer that turns off the radio automatically after a preset duration.

Press **SLEEP**.

The radio turns on. You can set the sleep timer to durations of 90, 60, 30, or 15 minutes. Every push changes the display as follows

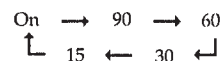

To turn off the radio before the preset time, press **SNOOZE/DATE/SLEEP OFF**.

## To Use Both Sleep Timer and Alarm

You can fall asleep to the radio and also be awakened by the radio or buzzer alarm at the preset time.

- 1 Set the alarm. (See "Setting the Alarm".)
- 2 Set the sleep timer. (See "Setting the Sleep Timer".)

## SECTION 2 DISASSEMBLY

**Note:** Follow the disassembly procedure in the numerical order given.

### CHASSIS ASS'Y

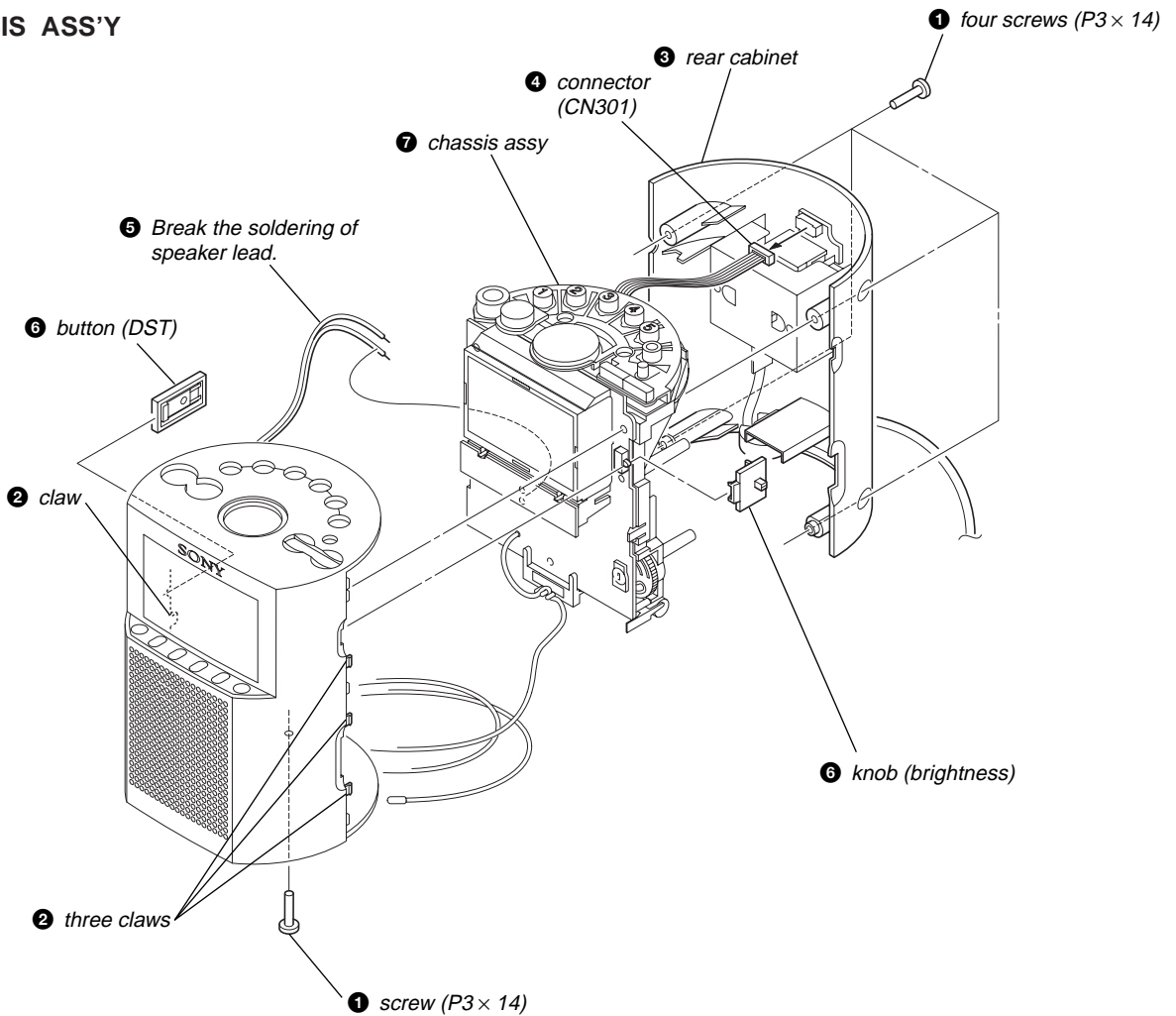

### POWER CORD SETTING

Set the power cord as illustrated below, then install the cabinet.

Put the secondary flat cable between bosses to fix.

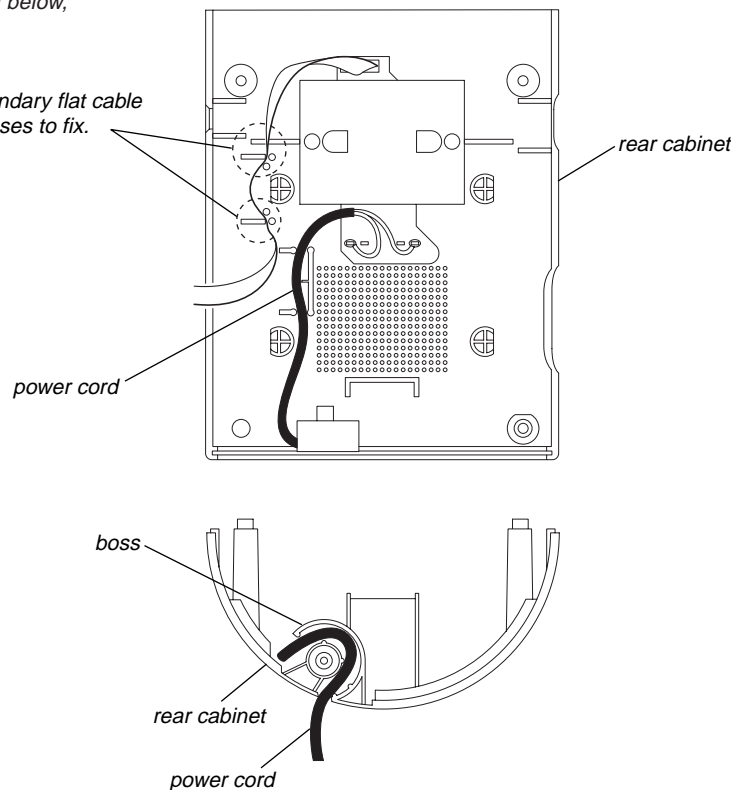

## SECTION 3 ELECTRICAL ADJUSTMENTS

0 dB = 1  $\mu$ V

### [FM]

#### Setting:

Band switch: FM

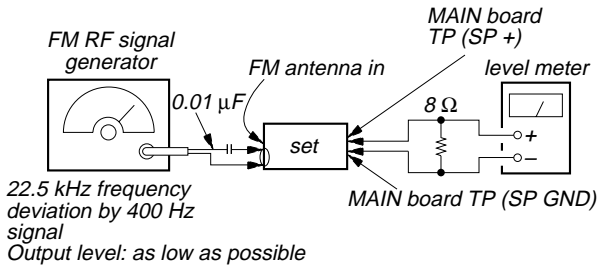

### [AM (MW/LW)\*]

\*AM : ICF-C793

MW/LW : ICF-C793L

#### Setting:

Band switch: AM (MW/LW)

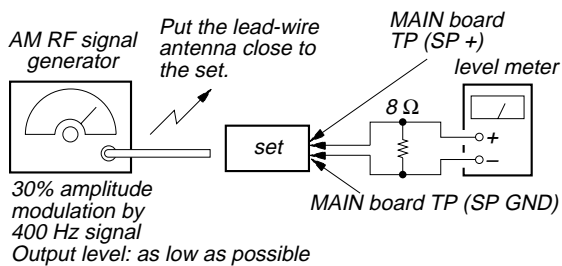

- Repeat the procedures in each adjustment several times, and the frequency coverage and tracking adjustments should be finally done by the trimmer capacitors.
- Remove FM antenna in FM adjustments.

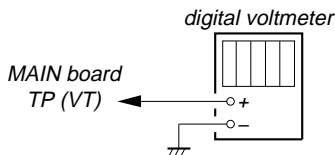

**Adjustment Location:** Main Board (See page 7)

### FM VCO VOLTAGE ADJUSTMENT

Adjustment Part	Frequency Display	Reading on Digital Voltmeter
L4	87.5 MHz	3 V $\pm$ 0.1V
Confirmation	108 MHz	Less than 11.8 V

### FM TRACKING ADJUSTMENT

Adjust for a maximum reading on level meter.

L3	87.5 MHz
TC3	108 MHz

### AM (MW) VCO VOLTAGE ADJUSTMENT

Adjustment Part	Frequency Display	Reading on Digital Voltmeter
L5	530 kHz (531kHz *1)	2.65 V $\pm$ 0.1V
Confirmation	1,710 kHz (1,602 kHz *1)	Less than 10 V (9.5 V *1)

### AM (MW) TRACKING ADJUSTMENT

Adjust for a maximum reading on level meter.

L1 (L1-1 *2)	580 kHz (621 kHz *1)
TC1	1,490 kHz (1,404 kHz *1)

### LW VCO VOLTAGE ADJUSTMENT \*2

Adjustment Part	Frequency Display	Reading on Digital Voltmeter
TC4	153 kHz	2.25 V $\pm$ 0.05V
Confirmation	279 kHz	Less than 9.5 V

### LW TRACKING ADJUSTMENT \*2

Adjust for a maximum reading on level meter.

L1-2	162 kHz
TC2	243 kHz

### AM IF ADJUSTMENT

Adjust for a maximum reading on level meter.

T1	450 kHz
----	---------

\*1) Except US, Canadian models

\*2) -ICF-C793L

**Adjustment Location:**

**- MAIN BOARD (Component Side) -**

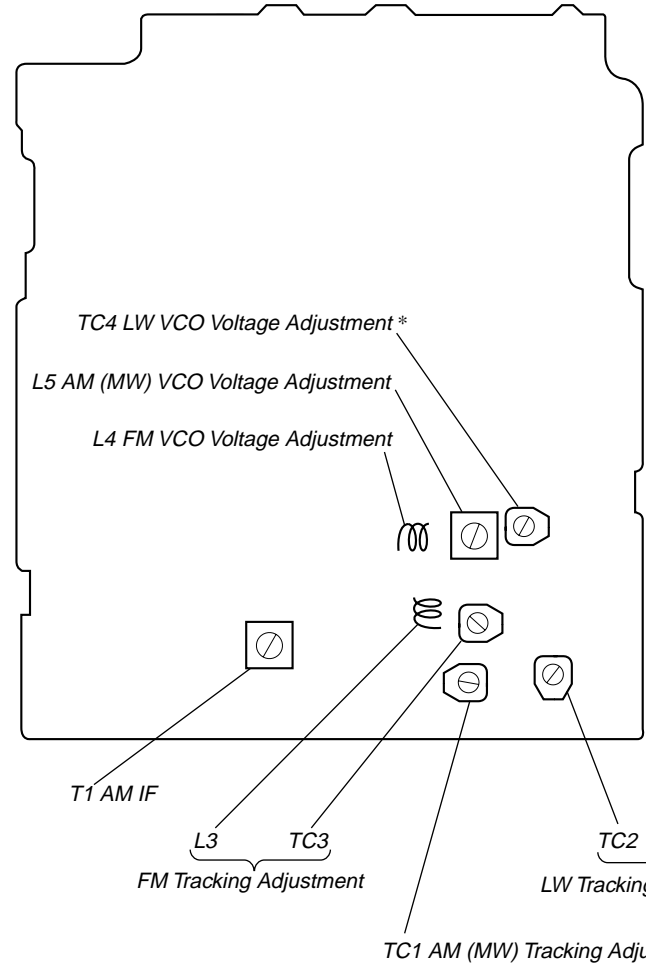

**- MAIN BOARD (Conductor Side) -**

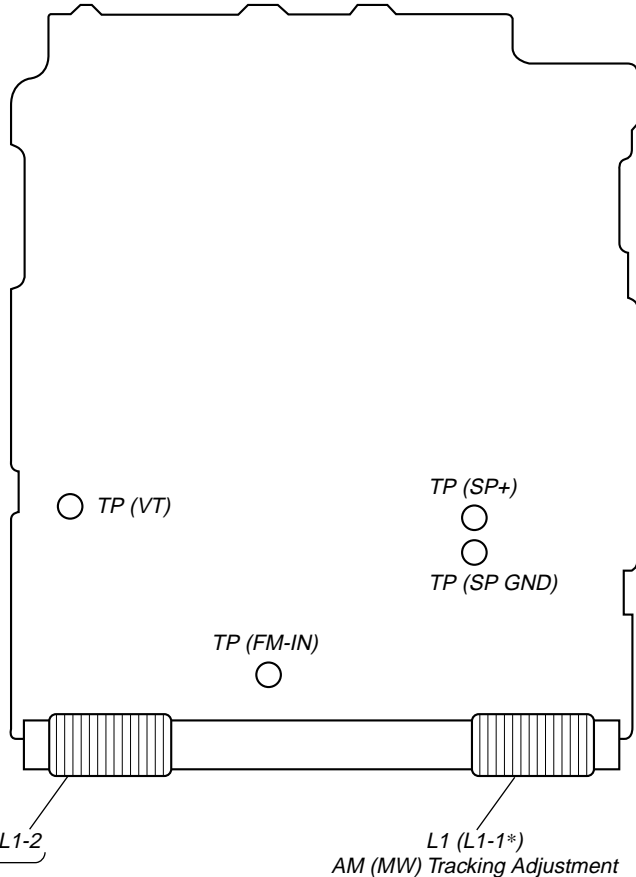

\*) ICF-C793L



SECTION 4  
DIAGRAMS

4-1. BLOCK DIAGRAM

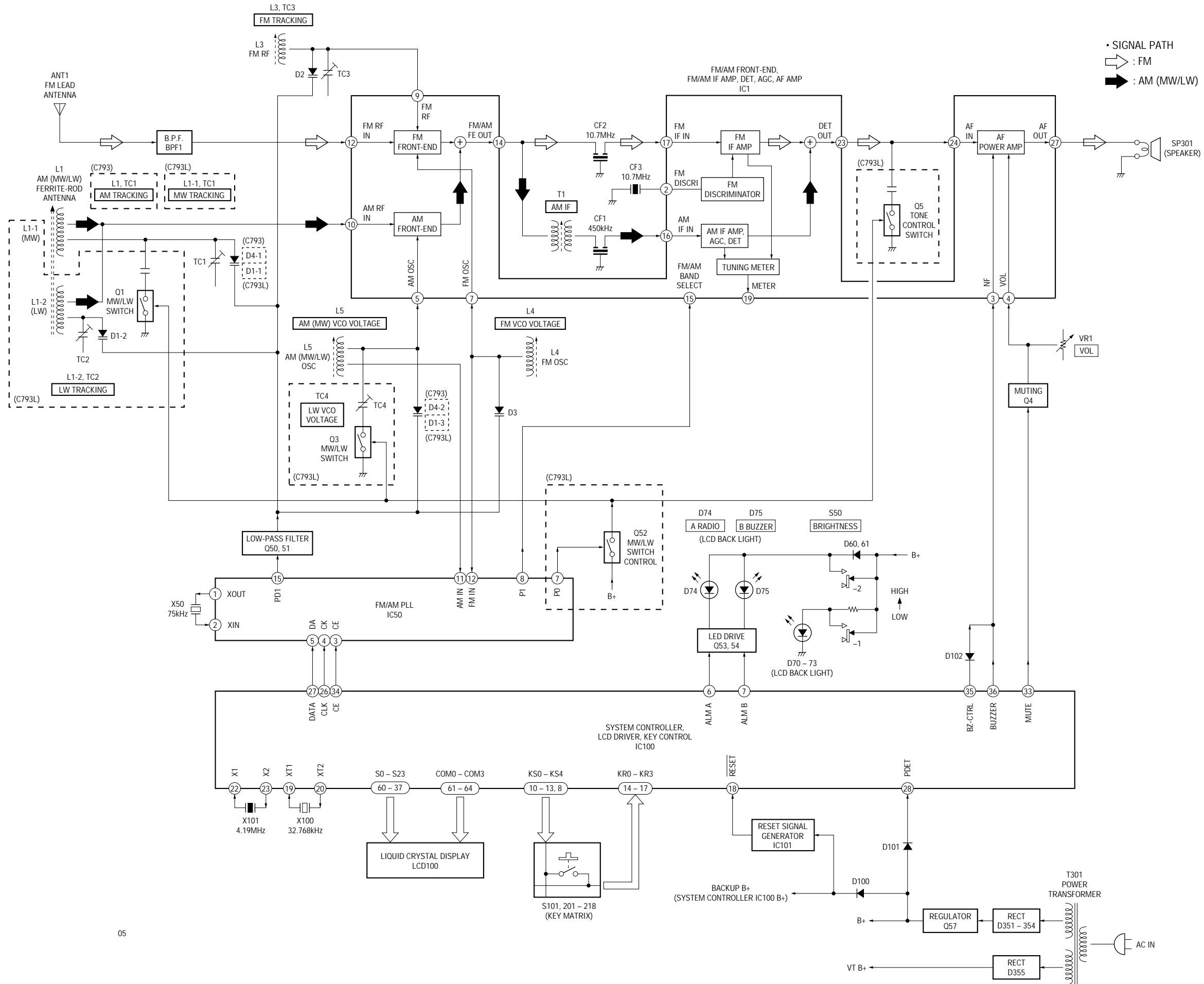

05



4-2. PRINTED WIRING BOARDS

• Semiconductor Location

Ref. No.	Location
D1	E-2
D2	E-2
D3	E-2
D4	E-2
D7	E-4
D8	E-4
D50	D-4
D60	B-2
D61	B-2
D70	A-2
D71	A-3
D72	A-4
D73	A-4
D74	B-4
D75	B-2
D100	D-5
D101	B-2
D102	C-2
D351	D-5
D352	E-5
D353	D-5
D354	E-5
D355	D-5
IC1	E-3
IC50	D-2
IC100	C-3
IC101	B-3
Q1	F-2
Q3	D-2
Q4	D-3
Q5	E-4
Q50	D-2
Q51	D-2
Q52	D-2
Q53	C-4
Q54	B-2
Q57	D-3

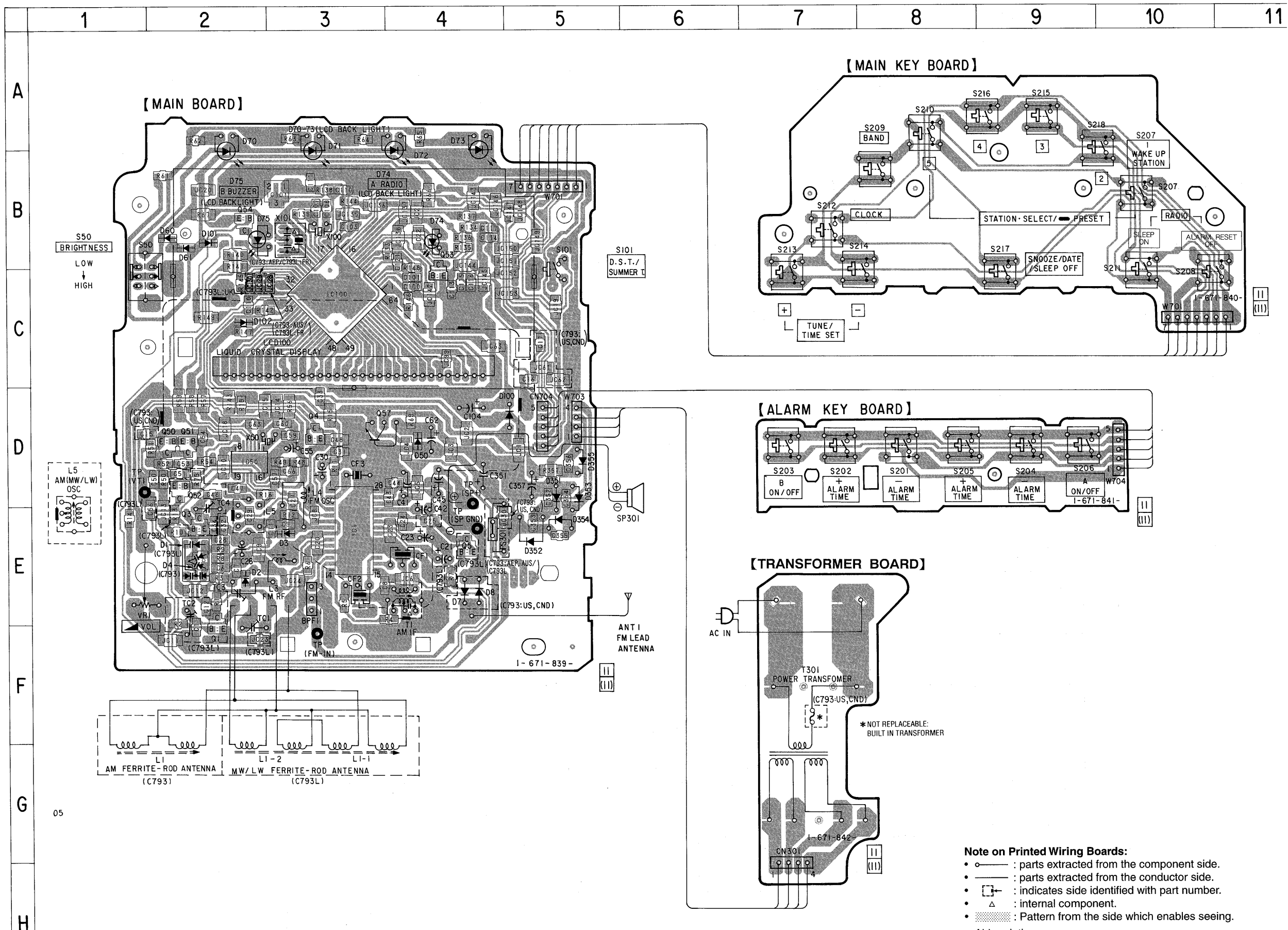

**Note on Printed Wiring Boards:**

- : parts extracted from the component side.
- : parts extracted from the conductor side.
- : indicates side identified with part number.
- △ : internal component.
- ▨ : Pattern from the side which enables seeing.

**Abbreviation**

- AUS : Australian model
- CND : Canadian model
- FR : French model

4-3. SCHEMATIC DIAGRAM

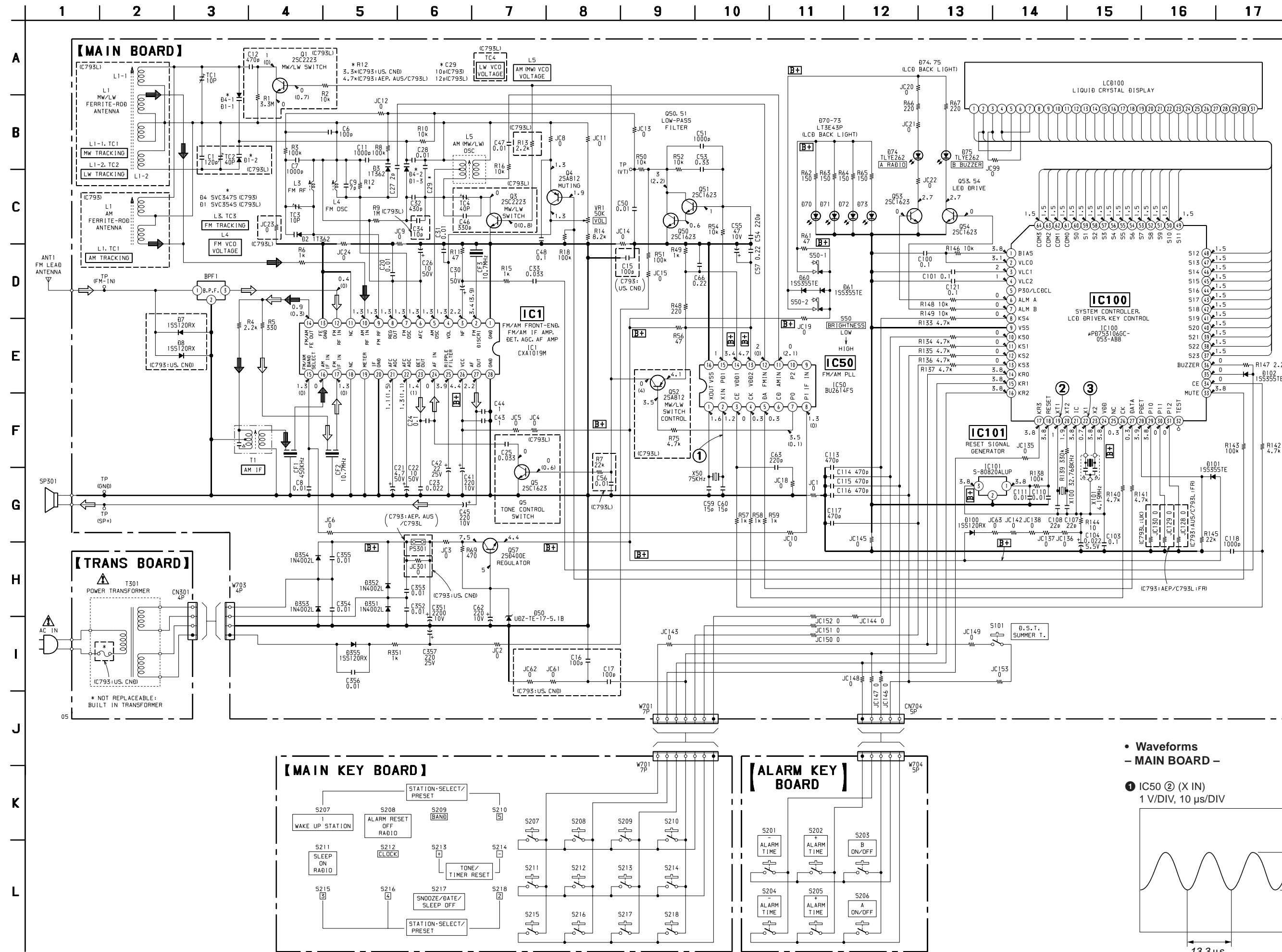

• IC Block Diagrams  
- MAIN BOARD -

IC1 CX1019M

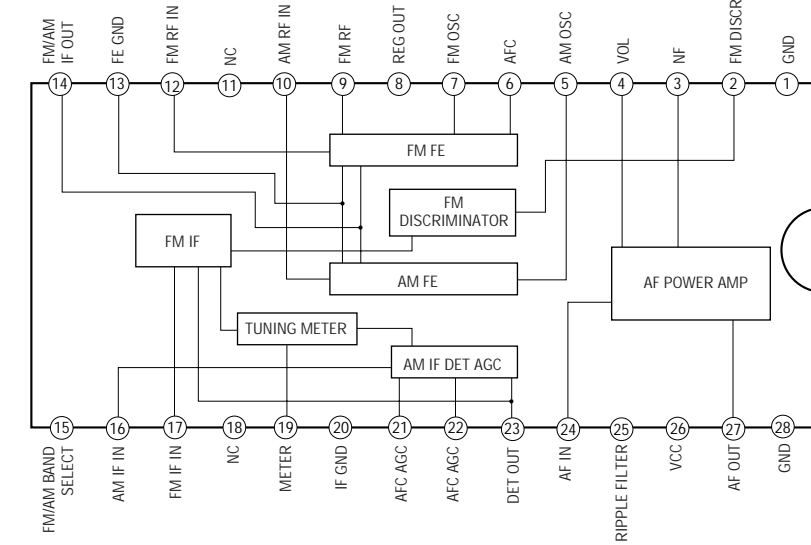

IC50 BU2614FS

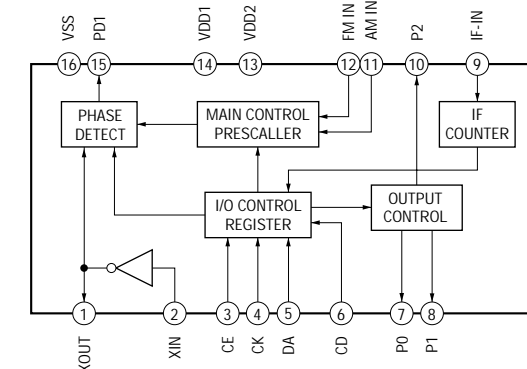

② IC100 (X T1)  
1 V/DIV, 20 μs/DIV

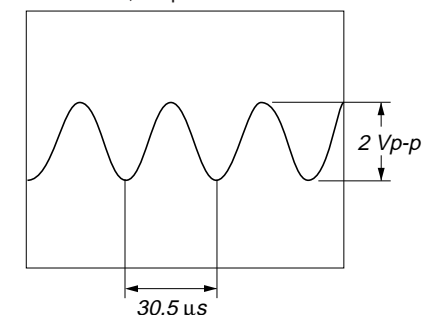

③ IC100 (X1)  
1 V/DIV, 500 ms/DIV

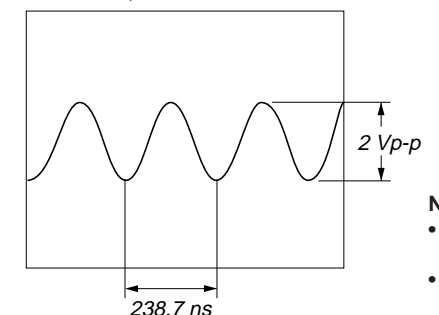

**Note on Schematic Diagram:**  
• All capacitors are in μF unless otherwise noted. pF: μF  
50 WV or less are not indicated except for electrolytics and tantalums.  
• All resistors are in Ω and 1/4 W or less unless otherwise specified.

• Δ : internal component.  
• □ : panel designation.

**Note:**  
The components identified by mark Δ or dotted line with mark Δ are critical for safety. Replace only with part number specified.

**Note:**  
Les composants identifiés par une marque Δ sont critiques pour la sécurité. Ne les remplacer que par une pièce portant le numéro spécifié.

• Waveforms  
- MAIN BOARD -

① IC50 (X IN)  
1 V/DIV, 10 μs/DIV

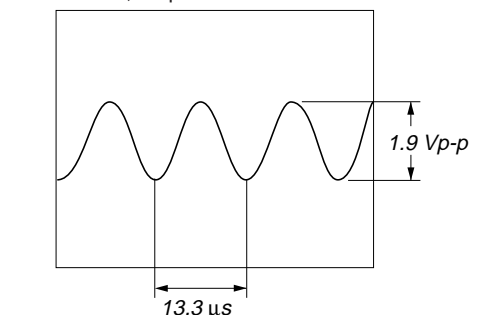

**Note:**  
• Press either ⊕ or ⊖ key when RADIO is being operated, oscillation will be given out for 250 ms.  
• Oscillation will be given out for 250 ms when the power is turned on.

#### 4-4. IC PIN FUNCTION DESCRIPTION

##### • MAIN BOARD IC100 $\mu$ PD753106GC-053-AB8 (SYSTEM CONTROLLER, LCD DRIVER, KEY CONTROL)

Pin No.	Pin Name	I/O	Description
1	BIAS	O	Liquid crystal display drive bias control output terminal
2 to 4	VLC0 to VLC2	—	Terminal for doubler circuit capacitor connection to develop liquid crystal display drive voltage
5	NC	O	Not used (open)
6	ALM A	O	LED drive signal output of the LCD back light LED (D74) “H” output at alarm A setting (LED on)
7	ALM B	O	LED drive signal output of the LCD back light LED (D75) “H” output at alarm B setting (LED on)
8	KS4	O	Key scan signal output of the key matrix (S101, S201 to S218)
9	VSS	—	Ground terminal
10 to 13	KS0 to KS3	O	Key scan signal output of the key matrix (S101, S201 to S218)
14 to 17	KR0 to KR3	I	Key return signal input of the key matrix (S101, S201 to S218)
18	$\overline{\text{RESET}}$	I	System reset signal input from the reset signal generator (IC101) “L”: reset “L” is input for several 100 msec after power on, then it changes to “H”
19	XT1	I	Sub system clock input terminal (32.768 kHz)
20	XT2	O	Sub system clock output terminal (32.768 kHz)
21	IC	—	Connected to power supply (+3.8V)
22	X1	I	Main system clock input terminal (4.19 MHz)
23	X2	O	Main system clock output terminal (4.19 MHz)
24	VDD	—	Power supply terminal (+3.8V)
25	NC	I	Not used (open)
26	CLK	O	PLL serial data transfer clock signal output to the FM/AM PLL (IC50)
27	DATA	O	PLL serial data output to the FM/AM PLL (IC50)
28	PDET	I	Power failure detection input terminal “L”: power failure
29 to 31	PI0 to PI2	I	Destination setting terminal *1
32	TFST	I	Test mode input terminal “L”: test mode Not used (open)
33	MUTE	O	Muting on/off control signal output terminal “L”: muting on
34	CE	O	PLL serial chip enable signal output to the FM/AM PLL (IC50)
35	BZ-CTRL	O	Buzzer control signal output terminal “H” output at alarm B active
36	BUZZER	O	Beep sound (2 kHz) drive signal output to the CXA1019M (IC1)
37 to 60	S23 to S0	O	Segment drive signal output to the liquid crystal display (LCD100)
61 to 64	COM0 to COM3	O	Common drive signal output to the liquid crystal display (LCD100)

\*1

	ICF-C793			ICF-C793L	
	US, Canadian	AEP	Australian	French	UK
PI0 (pin 29)	“H”	“H”	“H”	“H”	“L”
PI1 (pin 30)	“H”	“L”	“H”	“L”	“H”
PI2 (pin 31)	“H”	“H”	“L”	“L”	“H”

## SECTION 5 EXPLODED VIEWS

**NOTE:**

- -XX and -X mean standardized parts, so they may have some difference from the original one.
- Color Indication of Appearance Parts  
Example:  
KNOB, BALANCE (WHITE) . . . (RED)  
                                          ↑                                          ↑  
                                          Parts Color   Cabinet's Color

- Items marked "\*" are not stocked since they are seldom required for routine service. Some delay should be anticipated when ordering these items.
- The mechanical parts with no reference number in the exploded views are not supplied.
- Accessories and packing materials are given in the last of the electrical parts list.

The components identified by mark  $\Delta$  or dotted line with mark  $\Delta$  are critical for safety. Replace only with part number specified.

Les composants identifiés par une marque  $\Delta$  sont critiques pour la sécurité. Ne les remplacer que par une pièce portant le numéro spécifié.

- Abbreviation  
AUS : Australian model  
CND : Canadian model  
FR : French model

**(1) CABINET SECTION**

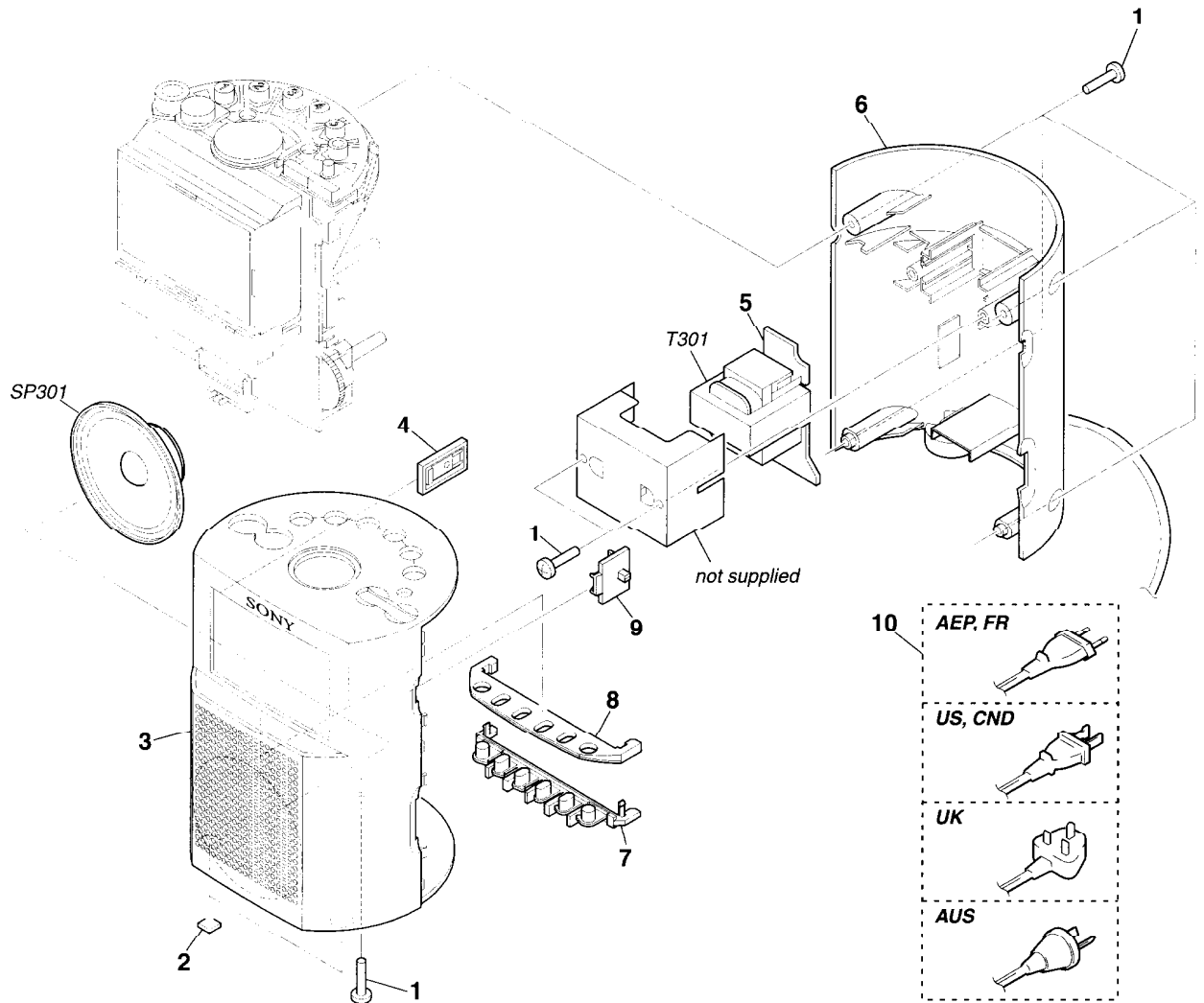

Ref. No.	Part No.	Description	Remark	Ref. No.	Part No.	Description	Remark
1	7-685-649-79	SCREW +P 3X14 TYPE2 NON-SLIT		9	3-032-460-01	KNOB (BRIGHTNESS)	
2	3-368-852-01	FOOT		$\Delta$ 10	1-555-795-00	CORD, POWER (C793: AEP/C793L: FR)	
3	X-3377-454-1	CABINET (FRONT) SUB ASSY (C793: AEP, AUS)		$\Delta$ 10	1-696-572-21	CORD, POWER (C793L: UK)	
3	X-3377-083-1	CABINET ASSY (C793: US, CND)		$\Delta$ 10	1-783-817-11	CORD, POWER (C793: US, CND)	
3	X-3377-215-1	CABINET ASSY (C793L)		$\Delta$ 10	1-790-431-11	CORD, POWER (C793: AUS)	
4	3-032-463-01	BUTTON (DST)		SP301	1-504-748-21	SPEAKER (6.6cm)	
* 5	1-671-842-11	TRANSFORMER BOARD		$\Delta$ T301	1-433-600-11	TRANSFORMER, POWER (C793: US, CND)	
6	3-032-458-01	CABINET (REAR)		$\Delta$ T301	1-433-601-11	TRANSFORMER, POWER (C793: AEP, AUS/C793L)	
7	3-032-462-01	BUTTON (ALARM)					
8	3-032-465-01	PANEL (ALARM)					

(2) CHASSIS SECTION

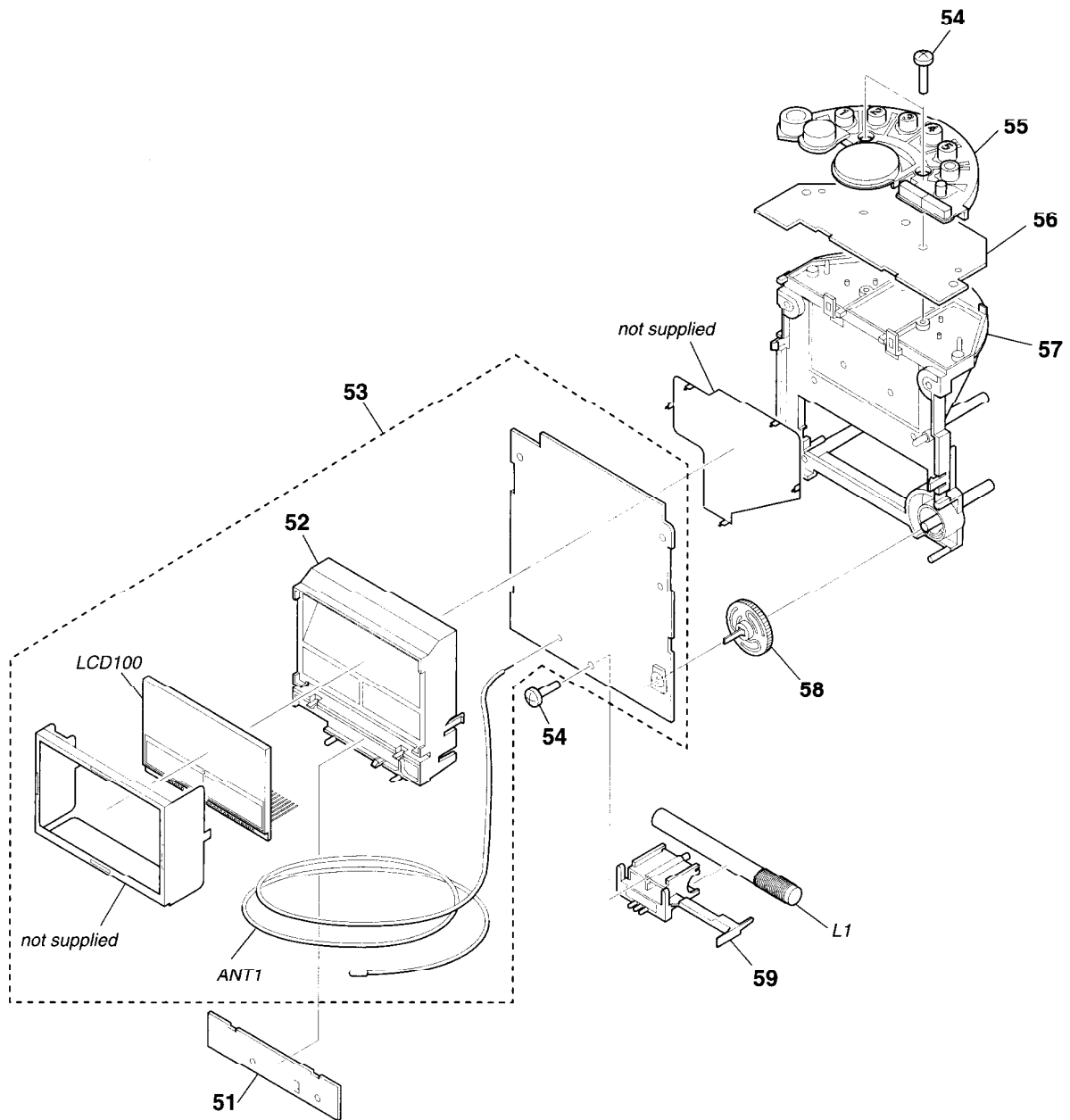

Ref. No.	Part No.	Description	Remark	Ref. No.	Part No.	Description	Remark
* 51	1-671-841-11	ALARM KEY BOARD		* 56	1-671-840-11	MAIN KEY BOARD	
52	3-032-464-01	HOLDER (LCD)		57	3-032-459-01	CHASSIS	
53	A-3663-208-A	MAIN BOARD, COMPLETE (C793: US, CND)		58	3-919-268-01	KNOB (VOL)	
53	A-3663-266-A	MAIN BOARD, COMPLETE (C793: AUS)		59	3-033-972-01	HOLDER, FERRITE-ROD ANTENNA	
53	A-3663-268-A	MAIN BOARD, COMPLETE (C793: AEP)		L1	1-754-039-11	ANTENNA, FERRITE-ROD (AM) (C793)	
53	A-3663-272-A	MAIN BOARD, COMPLETE (C793L: FR)		L1	1-754-040-11	ANTENNA, FERRITE-ROD (LW/MW) (C793L)	
53	A-3663-275-A	MAIN BOARD, COMPLETE (C793L: UK)		LCD100	1-803-446-11	DISPLAY PANEL, LIQUID CRYSTAL	
54	7-685-649-79	SCREW +P 3X14 TYPE2 NON-SLIT		ANT1	1-501-907-21	ANTENNA, FM WIRE (FM LEAD ANTENNA)	
55	3-032-461-01	BUTTON (MAIN)					

# SECTION 6 ELECTRICAL PARTS LIST

**ALARM KEY**

**MAIN**

**NOTE:**

- Due to standardization, replacements in the parts list may be different from the parts specified in the diagrams or the components used on the set.
- -XX and -X mean standardized parts, so they may have some difference from the original one.
- **RESISTORS**  
All resistors are in ohms.  
METAL: Metal-film resistor.  
METAL OXIDE: Metal oxide-film resistor.  
F: nonflammable
- **Abbreviation**  
AUS : Australian model  
CND : Canadian model  
FR : French model

- Items marked “\*” are not stocked since they are seldom required for routine service. Some delay should be anticipated when ordering these items.
- **SEMICONDUCTORS**  
In each case, u:  $\mu$ , for example:  
uA. . :  $\mu$ A. .      uPA. . :  $\mu$ PA. .  
uPB. . :  $\mu$ PB. .    uPC. . :  $\mu$ PC. .  
uPD. . :  $\mu$ PD. .
- **CAPACITORS**  
uF:  $\mu$ F
- **COILS**  
uH:  $\mu$ H

The components identified by mark  $\Delta$  or dotted line with mark  $\Delta$  are critical for safety. Replace only with part number specified.

Les composants identifiés par une marque  $\Delta$  sont critiques pour la sécurité. Ne les remplacer que par une pièce portant le numéro spécifié.

When indicating parts by reference number, please include the board.

Ref. No.	Part No.	Description	Remark	Ref. No.	Part No.	Description	Remark
*	1-671-841-11	ALARM KEY BOARD *****		C22	1-126-964-11	ELECT 10uF 20%	50V
		<SWITCH>		C23	1-163-063-00	CERAMIC CHIP 0.022uF 10%	50V
				C24	1-164-004-11	CERAMIC CHIP 0.1uF 10%	25V
S201	1-553-856-00	SWITCH, KEYBOARD (-, ALARM TIME)		C25	1-163-989-11	CERAMIC CHIP 0.033uF 10%	25V (C793L)
S202	1-553-856-00	SWITCH, KEYBOARD (+, ALARM TIME)		C26	1-126-964-11	ELECT 10uF 20%	50V
S203	1-553-856-00	SWITCH, KEYBOARD (B, ON/OFF)		C27	1-163-085-00	CERAMIC CHIP 2PF	50V
S204	1-553-856-00	SWITCH, KEYBOARD (-, ALARM TIME)		C28	1-163-021-11	CERAMIC CHIP 0.01uF 10%	50V
S205	1-553-856-00	SWITCH, KEYBOARD (+, ALARM TIME)		C29	1-163-227-11	CERAMIC CHIP 10PF 0.5PF	50V (C793)
S206	1-553-856-00	SWITCH, KEYBOARD (A, ON/OFF)		C29	1-163-229-11	CERAMIC CHIP 12PF 5%	50V (C793L)
*****				C30	1-126-960-11	ELECT 1uF 20%	50V
	A-3663-208-A	MAIN BOARD, COMPLETE (C793: US, CND)		C31	1-163-021-11	CERAMIC CHIP 0.01uF 10%	50V
	A-3663-266-A	MAIN BOARD, COMPLETE (C793: AUS)		C32	1-163-132-00	CERAMIC CHIP 430PF 5%	50V
	A-3663-268-A	MAIN BOARD, COMPLETE (C793: AEP)		C33	1-163-989-11	CERAMIC CHIP 0.033uF 10%	25V
	A-3663-272-A	MAIN BOARD, COMPLETE (C793L: FR)		C34	1-163-227-11	CERAMIC CHIP 10PF 0.5PF	50V (C793L)
	A-3663-275-A	MAIN BOARD, COMPLETE (C793L: UK)		C41	1-126-934-11	ELECT 220uF 20%	10V
		*****		C42	1-128-551-11	ELECT 22uF 20%	25V
	3-032-464-01	HOLDER (LCD)		C43	1-109-982-11	CERAMIC CHIP 1uF 10%	10V
		<ANTENNA>		C44	1-109-982-11	CERAMIC CHIP 1uF 10%	10V
ANT1	1-501-907-21	ANTENNA, FM WIRE (FM LEAD ANTENNA)		C45	1-126-934-11	ELECT 220uF 20%	10V
		<BAND PASS FILTER>		C46	1-163-263-11	CERAMIC CHIP 330PF 5%	50V (C793L)
BPF1	1-236-711-21	FILTER, BAND PASS		C47	1-163-021-11	CERAMIC CHIP 0.01uF 10%	50V
		<CAPACITOR>		C48	1-163-077-00	CERAMIC CHIP 0.1uF 10%	25V
C1	1-163-253-11	CERAMIC CHIP 120PF 5%	50V (C793L)	C50	1-163-021-11	CERAMIC CHIP 0.01uF 10%	50V
C6	1-163-251-11	CERAMIC CHIP 100PF 5%	50V	C51	1-163-009-11	CERAMIC CHIP 0.001uF 10%	50V
C7	1-163-141-00	CERAMIC CHIP 0.001uF 5%	50V	C53	1-110-501-11	CERAMIC CHIP 0.33uF 10%	16V
C8	1-163-021-11	CERAMIC CHIP 0.01uF 10%	50V	C54	1-163-125-00	CERAMIC CHIP 220PF 5%	50V
C9	1-163-224-11	CERAMIC CHIP 7PF 0.25PF	50V	C55	1-104-664-11	ELECT 47uF 20%	10V
C11	1-163-141-00	CERAMIC CHIP 0.001uF 5%	50V	C56	1-163-021-11	CERAMIC CHIP 0.01uF 10%	50V (C793L)
C12	1-163-133-00	CERAMIC CHIP 470PF 5%	50V (C793L)	C57	1-115-340-11	CERAMIC CHIP 0.22uF 10%	16V
C15	1-163-251-11	CERAMIC CHIP 100PF 5%	50V (C793: US, CND)	C59	1-163-231-11	CERAMIC CHIP 15PF 5%	50V
C16	1-163-251-11	CERAMIC CHIP 100PF 5%	50V (C793: US, CND)	C60	1-163-231-11	CERAMIC CHIP 15PF 5%	50V
C17	1-163-251-11	CERAMIC CHIP 100PF 5%	50V (C793: US, CND)	C62	1-126-934-11	ELECT 220uF 20%	10V
C20	1-163-059-91	CERAMIC CHIP 0.01uF 10%	50V	C63	1-163-125-00	CERAMIC CHIP 220PF 5%	50V
C21	1-126-963-11	ELECT 4.7uF 20%	50V	C66	1-164-489-11	CERAMIC CHIP 0.22uF 10%	16V
				C100	1-163-038-00	CERAMIC CHIP 0.1uF	25V
				C101	1-163-038-00	CERAMIC CHIP 0.1uF	25V
				C103	1-164-004-11	CERAMIC CHIP 0.1uF 10%	25V
				C104	1-125-691-11	DOUBLE LAYER 0.022F	5.5V



# MAIN

Ref. No.	Part No.	Description	Remark	Ref. No.	Part No.	Description	Remark
C107	1-163-235-11	CERAMIC CHIP 22PF	5% 50V	IC100	8-759-571-48	IC uPD753106GC-053-AB8	
C108	1-163-235-11	CERAMIC CHIP 22PF	5% 50V	IC101	8-759-580-04	IC S-80820ALUP-EAH-T2	
C110	1-163-021-11	CERAMIC CHIP 0.01uF	10% 50V			<SHORT>	
C111	1-163-021-11	CERAMIC CHIP 0.01uF	10% 50V				
C113	1-163-133-00	CERAMIC CHIP 470PF	5% 50V	JC1	1-216-296-00	SHORT	0
C114	1-163-133-00	CERAMIC CHIP 470PF	5% 50V	JC2	1-216-296-00	SHORT	0
C115	1-163-133-00	CERAMIC CHIP 470PF	5% 50V	JC3	1-216-296-00	SHORT	0
C116	1-163-133-00	CERAMIC CHIP 470PF	5% 50V	JC4	1-216-296-00	SHORT	0
C117	1-163-133-00	CERAMIC CHIP 470PF	5% 50V	JC5	1-216-296-00	SHORT	0
C118	1-163-009-11	CERAMIC CHIP 0.001uF	10% 50V	JC6	1-216-296-00	SHORT	0
C121	1-163-038-00	CERAMIC CHIP 0.1uF	25V	JC8	1-216-295-00	SHORT	0
C351	1-126-927-11	ELECT 2200uF	20% 10V	JC9	1-216-296-00	SHORT	0
C352	1-163-021-11	CERAMIC CHIP 0.01uF	10% 50V	JC10	1-216-296-00	SHORT	0
C353	1-163-021-11	CERAMIC CHIP 0.01uF	10% 50V	JC11	1-216-296-00	SHORT	0
C354	1-163-021-11	CERAMIC CHIP 0.01uF	10% 50V	JC12	1-216-296-00	SHORT	0
C355	1-163-021-11	CERAMIC CHIP 0.01uF	10% 50V	JC13	1-216-296-00	SHORT	0
C356	1-163-021-11	CERAMIC CHIP 0.01uF	10% 50V	JC14	1-216-296-00	SHORT	0
C357	1-104-666-11	ELECT 220uF	20% 25V	JC15	1-216-296-00	SHORT	0
		<FILTER>		JC18	1-216-296-00	SHORT	0
* CF1	1-577-319-11	FILTER, CERAMIC (450kHz) (C793)		JC19	1-216-296-00	SHORT	0
CF1	1-578-677-21	FILTER, CRYSTAL (450kHz) (C793L)		JC20	1-216-296-00	SHORT	0
CF2	1-579-632-41	FILTER, CERAMIC (10.7MHz)		JC21	1-216-296-00	SHORT	0
CF3	1-579-632-41	FILTER, CERAMIC (10.7MHz)		JC22	1-216-296-00	SHORT	0
		<CONNECTOR>		JC23	1-216-295-00	SHORT	0 (C793L)
* CN704	1-568-271-11	SOCKET, CONNECTOR 5P		JC24	1-216-296-00	SHORT	0
		<DIODE>		JC61	1-216-296-00	SHORT	0 (C793: US, CND)
D1	8-719-057-59	DIODE SVC354S-TR (C793L)		JC62	1-216-296-00	SHORT	0 (C793: US, CND)
D2	8-713-100-11	DIODE 1T362		JC63	1-216-296-00	SHORT	0
D3	8-713-100-11	DIODE 1T362		JC99	1-216-295-00	SHORT	0
D4	8-719-072-59	DIODE SVC347S-TL (C793)		JC128	1-216-295-00	SHORT	0 (C793: AUS/C793L: FR)
D7	8-719-074-44	DIODE 1SS120RX (C793: US, CND)		JC129	1-216-295-00	SHORT	0 (C793: AEP/C793L: FR)
D8	8-719-074-44	DIODE 1SS120RX (C793: US, CND)		JC130	1-216-295-00	SHORT	0 (C793L: UK)
D50	8-719-976-99	DIODE DTZ5.1B		JC135	1-216-296-00	SHORT	0
D60	8-719-988-61	DIODE 1SS355TE-17		JC136	1-216-296-00	SHORT	0
D61	8-719-988-61	DIODE 1SS355TE-17		JC137	1-216-296-00	SHORT	0
D70	8-719-950-41	LED GL-3EG43 (LCD BACK LIGHT)		JC138	1-216-296-00	SHORT	0
D71	8-719-950-41	LED GL-3EG43 (LCD BACK LIGHT)		JC142	1-216-296-00	SHORT	0
D72	8-719-950-41	LED GL-3EG43 (LCD BACK LIGHT)		JC143	1-216-296-00	SHORT	0
D73	8-719-950-41	LED GL-3EG43 (LCD BACK LIGHT)		JC144	1-216-296-00	SHORT	0
D74	8-719-073-99	LED TLYE262(NP.TPK51) (A RADIO, LCD BACK LIGHT)		JC145	1-216-296-00	SHORT	0
D75	8-719-073-99	LED TLYE262(NP.TPK51) (B BUZZER, LCD BACK LIGHT)		JC146	1-216-296-00	SHORT	0
D100	8-719-074-44	DIODE 1SS120RX		JC147	1-216-295-00	SHORT	0
D101	8-719-988-61	DIODE 1SS355TE-17		JC148	1-216-296-00	SHORT	0
D102	8-719-988-61	DIODE 1SS355TE-17		JC149	1-216-296-00	SHORT	0
D351	8-719-031-85	DIODE 1N4002L		JC150	1-216-296-00	SHORT	0
D352	8-719-031-85	DIODE 1N4002L		JC151	1-216-296-00	SHORT	0
D353	8-719-031-85	DIODE 1N4002L		JC152	1-216-296-00	SHORT	0
D354	8-719-031-85	DIODE 1N4002L		JC153	1-216-296-00	SHORT	0
D355	8-719-074-44	DIODE 1SS120RX		JC301	1-216-295-00	SHORT	0 (C793: US, CND)
		<IC>				<COIL>	
IC1	8-752-050-16	IC CXA1019M		L3	1-406-545-11	COIL, AIR-CORE	
IC50	8-759-188-85	IC BU2614FS		L4	1-406-545-11	COIL, AIR-CORE	
				L5	1-406-485-11	COIL (OSC)	
						<LIQUID CRYSTAL DISPLAY>	
				LCD100	1-803-446-11	DISPLAY PANEL, LIQUID CRYSTAL	



Ref. No.	Part No.	Description	Remark	Ref. No.	Part No.	Description	Remark
		<IC LINK>		R75	1-216-065-00	RES, CHIP 4.7K 5%	1/10W (C793L)
PS301	1-533-588-11	LINK, IC (C793: AEP, AUS/C793L)		R133	1-216-065-00	RES, CHIP 4.7K 5%	1/10W
		<TRANSISTOR>		R134	1-216-065-00	RES, CHIP 4.7K 5%	1/10W
Q1	8-729-102-07	TRANSISTOR 2SC2223-F13 (C793L)		R135	1-216-065-00	RES, CHIP 4.7K 5%	1/10W
Q3	8-729-102-07	TRANSISTOR 2SC2223-F13 (C793L)		R136	1-216-065-00	RES, CHIP 4.7K 5%	1/10W
Q4	8-729-216-22	TRANSISTOR 2SA1162-G		R137	1-216-065-00	RES, CHIP 4.7K 5%	1/10W
Q5	8-729-120-28	TRANSISTOR 2SC1623-L5L6 (C793L)		R138	1-216-097-00	RES, CHIP 100K 5%	1/10W
Q50	8-729-120-28	TRANSISTOR 2SC1623-L5L6		R139	1-216-109-00	METAL CHIP 330K 5%	1/10W
Q51	8-729-120-28	TRANSISTOR 2SC1623-L5L6		R140	1-216-214-00	RES, CHIP 4.7K 5%	1/8W
Q52	8-729-216-22	TRANSISTOR 2SA1162-G (C793L)		R141	1-216-214-00	RES, CHIP 4.7K 5%	1/8W
Q53	8-729-120-28	TRANSISTOR 2SC1623-L5L6		R142	1-216-065-00	RES, CHIP 4.7K 5%	1/10W
Q54	8-729-120-28	TRANSISTOR 2SC1623-L5L6		R143	1-216-246-00	RES, CHIP 100K 5%	1/8W
Q57	8-729-840-00	TRANSISTOR 2SD400-E		R144	1-216-001-00	METAL CHIP 10 5%	1/10W
		<RESISTOR>		R145	1-216-081-00	METAL CHIP 22K 5%	1/10W
R1	1-216-133-00	METAL CHIP 3.3M 5%	1/10W (C793L)	R146	1-216-073-00	METAL CHIP 10K 5%	1/10W
R2	1-216-073-00	RES, CHIP 10K 5%	1/10W (C793L)	R147	1-216-057-00	METAL CHIP 2.2K 5%	1/10W
R3	1-216-097-00	RES, CHIP 100K 5%	1/10W	R148	1-216-073-00	METAL CHIP 10K 5%	1/10W
R4	1-216-057-00	METAL CHIP 2.2K 5%	1/10W	R149	1-216-222-95	RES, CHIP 10K 10%	1/8W
R5	1-216-037-00	METAL CHIP 330 5%	1/10W	R351	1-216-198-00	RES, CHIP 1K 5%	1/8W
R6	1-216-049-11	RES, CHIP 1K 5%	1/10W			<SWITCH>	
R7	1-216-081-00	METAL CHIP 22K 5%	1/10W (C793L)	S50	1-571-478-11	SWITCH, SLIDE (BRIGHTNESS)	
R8	1-216-097-00	RES, CHIP 100K 5%	1/10W	S101	1-554-088-00	SWITCH, KEY BOARD (D. S. T./SUMMER T.)	
R9	1-216-121-00	RES, CHIP 1M 5%	1/10W			<TRANSFORMER>	
R10	1-216-073-00	METAL CHIP 10K 5%	1/10W	T1	1-404-790-11	TRANSFORMER, IF	
R11	1-216-017-00	RES, CHIP 47 5%	1/10W			<VARIABLE CAPACITOR>	
R12	1-216-061-00	METAL CHIP 3.3K 5%	1/10W (C793: US, CND)	TC1	1-141-601-21	CAP, ADJ 10PF	
R12	1-216-065-00	RES, CHIP 4.7K 5%	1/10W (C793: AEP, AUS/C793L)	TC2	1-141-605-21	CAP, ADJ 40PF (C793L)	
R13	1-216-057-00	METAL CHIP 2.2K 5%	1/10W (C793L)	TC3	1-141-601-21	CAP, ADJ 10PF	
R14	1-216-071-00	METAL CHIP 8.2K 5%	1/10W	TC4	1-141-605-21	CAP, ADJ 40PF (C793L)	
R15	1-216-198-00	RES, CHIP 1K 5%	1/8W			<VARIABLE RESISTOR>	
R16	1-216-073-00	METAL CHIP 10K 5%	1/10W	VR1	1-228-790-00	RES, VAR, CARBON 50K (VOL)	
R18	1-216-097-00	RES, CHIP 100K 5%	1/10W			<VIBRATOR>	
R48	1-216-033-00	METAL CHIP 220 5%	1/10W	X50	1-767-517-11	VIBRATOR, CRYSTAL (75kHz)	
R49	1-216-049-11	RES, CHIP 1K 5%	1/10W	X100	1-567-098-41	VIBRATOR, CRYSTAL (32.768kHz)	
R50	1-216-073-00	METAL CHIP 10K 5%	1/10W	X101	1-760-641-21	VIBRATOR, CERAMIC (4.19MHz)	
R51	1-216-097-00	RES, CHIP 100K 5%	1/10W	*****			
R52	1-216-073-00	METAL CHIP 10K 5%	1/10W	*	1-671-840-11	MAIN KEY BOARD	
R54	1-216-073-00	METAL CHIP 10K 5%	1/10W			*****	
R56	1-216-166-00	RES, CHIP 47 5%	1/8W			<SWITCH>	
R57	1-216-198-00	RES, CHIP 1K 5%	1/8W	S207	1-553-856-00	SWITCH, KEYBOARD (1, WAKE UP STATION)	
R58	1-216-198-00	RES, CHIP 1K 5%	1/8W	S208	1-553-856-00	SWITCH, KEYBOARD (ALARM RESET, RADIO OFF)	
R59	1-216-198-00	RES, CHIP 1K 5%	1/8W	S209	1-553-856-00	SWITCH, KEYBOARD (BAND)	
R61	1-216-017-00	RES, CHIP 47 5%	1/10W	S210	1-553-856-00	SWITCH, KEYBOARD (5)	
R62	1-216-029-00	METAL CHIP 150 5%	1/10W	S211	1-553-856-00	SWITCH, KEYBOARD (SLEEP, RADIO ON)	
R63	1-216-029-00	METAL CHIP 150 5%	1/10W	S212	1-553-856-00	SWITCH, KEYBOARD (CLOCK)	
R64	1-216-029-00	METAL CHIP 150 5%	1/10W	S213	1-553-856-00	SWITCH, KEYBOARD (+, TUNE/TIME SET)	
R65	1-216-029-00	METAL CHIP 150 5%	1/10W	S214	1-553-856-00	SWITCH, KEYBOARD (-, TUNE/TIME SET)	
R66	1-216-182-00	RES, CHIP 220 5%	1/8W	S215	1-553-856-00	SWITCH, KEYBOARD (3)	
R67	1-216-182-00	RES, CHIP 220 5%	1/8W	S216	1-553-856-00	SWITCH, KEYBOARD (4)	
R69	1-216-041-00	METAL CHIP 470 5%	1/10W				

# ICF-C793/C793L

## MAIN KEY

## TRANSFORMER

Ref. No.	Part No.	Description	Remark
S217	1-553-856-00	SWITCH, KEYBOARD (SNOOZE/DATA/SLEEP OFF)	
S218	1-553-856-00	SWITCH, KEYBOARD (2)	
*****			
*	1-671-842-11	TRANSFORMER BOARD *****	
*	1-535-771-11	TERMINAL (C793: AEP, AUS/C793L)  <CONNECTOR>	
* CN301	1-564-706-11	PIN, CONNECTOR (SMALL TYPE) 4P  <TRANSFORMER>	
△ T301	1-433-600-11	TRANSFORMER, POWER (C793: US, CND)	
△ T301	1-433-601-11	TRANSFORMER, POWER (C793: AEP, AUS/C793L)	
*****			
MISCELLANEOUS *****			
△ 10	1-555-795-00	CORD, POWER (C793: AEP/C793L: FR)	
△ 10	1-696-572-21	CORD, POWER (C793L: UK)	
△ 10	1-783-817-11	CORD, POWER (C793: US, CND)	
△ 10	1-790-431-11	CORD, POWER (C793: AUS)	
SP301	1-504-748-21	SPEAKER (6.6cm)	
L1	1-754-039-11	ANTENNA, FERRITE-ROD (AM) (C793)	
L1	1-754-040-11	ANTENNA, FERRITE-ROD (LW/MW) (C793L)	
*****			

### ACCESSORIES & PACKING MATERIALS

\*\*\*\*\*

- 3-865-471-11 MANUAL, INSTRUCTION  
(ENGLISH, FRENCH, GERMAN, DUTCH)  
(C793: CND, AEP, AUS/C793L)
- 3-865-471-21 MANUAL, INSTRUCTION (ENGLISH)  
(C793: US)
- 3-865-471-31 MANUAL, INSTRUCTION  
(ENGLISH, ITALIAN, SPANISH, PORTUGUESE)  
(C793: AEP/C793L: FR)
- 3-865-471-41 MANUAL, INSTRUCTION  
(ENGLISH, SWEDISH, DANISH, FINNISH)  
(C793: AEP)

The components identified by mark △ or dotted line with mark △ are critical for safety. Replace only with part number specified.

Les composants identifiés par une marque △ sont critiques pour la sécurité. Ne les remplacer que par une pièce portant le numéro spécifié.

# ICF-C793/C793L

## SERVICE MANUAL

Ver 1.1 1999.06



Photo: ICF-C793L

*US Model*  
*Canadian Model*  
*E Model*  
*Australian Model*  
ICF-C793  
*AEP Model*  
ICF-C793/C793L  
*UK Model*  
ICF-C793L

### SPECIFICATIONS

#### Time display

UK, Australia, North and South America	12 hour
Other countries	24 hour

#### Frequency range

Model for North and South America		
Band	ICF-C793	Channel stop
FM	87.5-108 MHz	0.1 MHz
AM	530-1,710 kHz	10 kHz

#### Model for other countries

Band	ICF-C793	ICF-C793L	Channel step
FM	87.5-108 MHz	87.5-108 MHz	0.05 MHz*
AM(MW)	531-1,602 kHz	531-1,602 kHz	9 kHz
LW	—	153 - 279 kHz	9 kHz

\* The frequency shown in the display changes in steps of 0.1 MHz.  
(Example: Frequency 88.05 MHz appears as "88.0 MHz".)

#### Speaker

Approx. 6.6 cm (2 5/8 in) dia.

#### Power output

150 mW (at 10% harmonic distortion)

#### Power requirements

North and South American model: 120 V AC, 60 Hz

Other models: 220-230 V AC, 50 Hz

#### Dimensions

Approx. 113 x 147.5 x 104.5 mm (w/h/d)  
(4 1/2 x 5 7/8 x 4 1/8 in) incl. projecting parts and controls

#### Mass

Approx. 730g (1 lb 10 oz)

ICF-C793L (UK model)

Approx. 780 g (1 lb 12 oz)

#### Supplied accessory

Manual Instruction (1)

Design and specifications are subject to change without notice.

ICF-C793

FM/AM PLL SYNTHESIZED CLOCK RADIO

ICF-C793L

FM/MW/LW PLL SYNTHESIZED CLOCK RADIO



SONY®

## TABLE OF CONTENTS

1.	<b>SERVICING NOTES</b> .....	3
2.	<b>GENERAL</b> .....	4
3.	<b>DISASSEMBLY</b> .....	6
4.	<b>ELECTRICAL ADJUSTMENTS</b> .....	7
5.	<b>DIAGRAMS</b>	
5-1.	Block Diagram .....	9
5-2.	IC Pin Function Description .....	11
5-3.	Schematic Diagram .....	13
5-4.	Printed Wiring Boards (SUFFIX-11) .....	15
5-5.	Printed Wiring Boards (SUFFIX-12) .....	17
6.	<b>EXPLODED VIEWS</b> .....	19
7.	<b>ELECTRICAL PARTS LIST</b> .....	21

## SAFETY CHECK-OUT

After correcting the original service problem, perform the following safety check before releasing the set to the customer: Check the antenna terminals, metal trim, "metallized" knobs, screws, and all other exposed metal parts for AC leakage. Check leakage as described below.

## LEAKAGE TEST

The AC leakage from any exposed metal part to earth ground and from all exposed metal parts to any exposed metal part having a return to chassis, must not exceed 0.5 mA (500 microamperes). Leakage current can be measured by any one of three methods.

1. A commercial leakage tester, such as the Simpson 229 or RCA WT-540A. Follow the manufacturers' instructions to use these instruments.
2. A battery-operated AC milliammeter. The Data Precision 245 digital multimeter is suitable for this job.
3. Measuring the voltage drop across a resistor by means of a VOM or battery-operated AC voltmeter. The "limit" indication is 0.75 V, so analog meters must have an accurate low-voltage scale. The Simpson 250 and Sanwa SH-63Trd are examples of a passive VOM that is suitable. Nearly all battery operated digital multimeters that have a 2 V AC range are suitable. (See Fig. A)

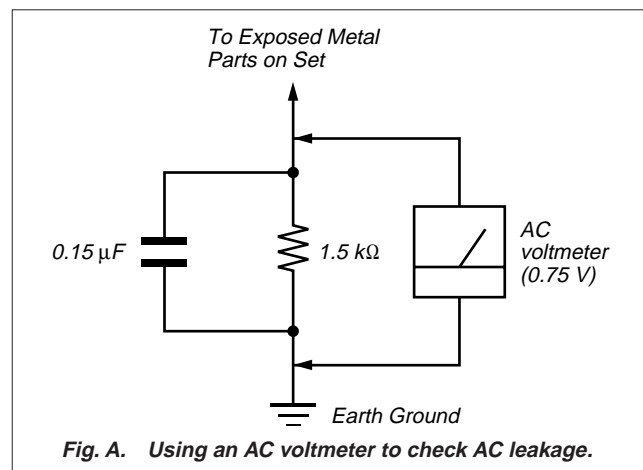

Fig. A. Using an AC voltmeter to check AC leakage.

## Notes on chip component replacement

- Never reuse a disconnected chip component.
- Notice that the minus side of a tantalum capacitor may be damaged by heat.

## SAFETY-RELATED COMPONENT WARNING!!

COMPONENTS IDENTIFIED BY MARK  $\triangle$  OR DOTTED LINE WITH MARK  $\triangle$  ON THE SCHEMATIC DIAGRAMS AND IN THE PARTS LIST ARE CRITICAL TO SAFE OPERATION. REPLACE THESE COMPONENTS WITH SONY PARTS WHOSE PART NUMBERS APPEAR AS SHOWN IN THIS MANUAL OR IN SUPPLEMENTS PUBLISHED BY SONY.

## ATTENTION AU COMPOSANT AYANT RAPPORT À LA SÉCURITÉ!

LES COMPOSANTS IDENTIFIÉS PAR UNE MARQUE  $\triangle$  SUR LES DIAGRAMMES SCHÉMATIQUES ET LA LISTE DES PIÈCES SONT CRITIQUES POUR LA SÉCURITÉ DE FONCTIONNEMENT. NE REMPLACER CES COMPOSANTS QUE PAR DES PIÈCES SONY DONT LES NUMÉROS SONT DONNÉS DANS CE MANUEL OU DANS LES SUPPLÉMENTS PUBLIÉS PAR SONY.

# SECTION 1 SERVICING NOTES

- Discrimination of MAIN board
- MAIN BOARD (Component Side) –

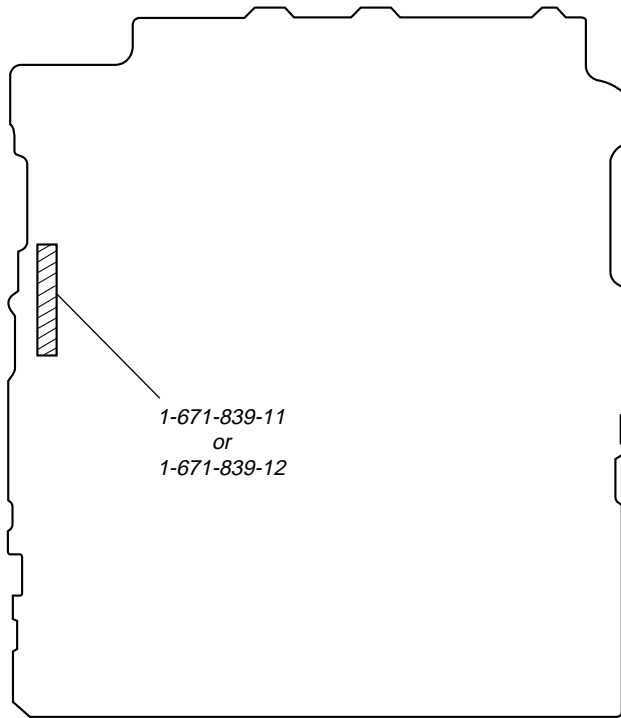

## HOW TO CHANGED THE CERAMIC FILTERS

This model is used two ceramic filters of CF2 and CF3. You must used same type of color marked ceramic filters in order to meet same specifications. Therefore, the ceramic filter must changed two pieces together since it's supply two pieces in one package as a spare parts.

	Mark	Center frequency
	red	10.70 MHz
	blue	10.67 MHz
	orange	10.73 MHz
	black	10.64 MHz
	white	10.76 MHz

## SECTION 2 GENERAL

This section is extracted from instruction manual.

### LOCATION OF CONTROLS

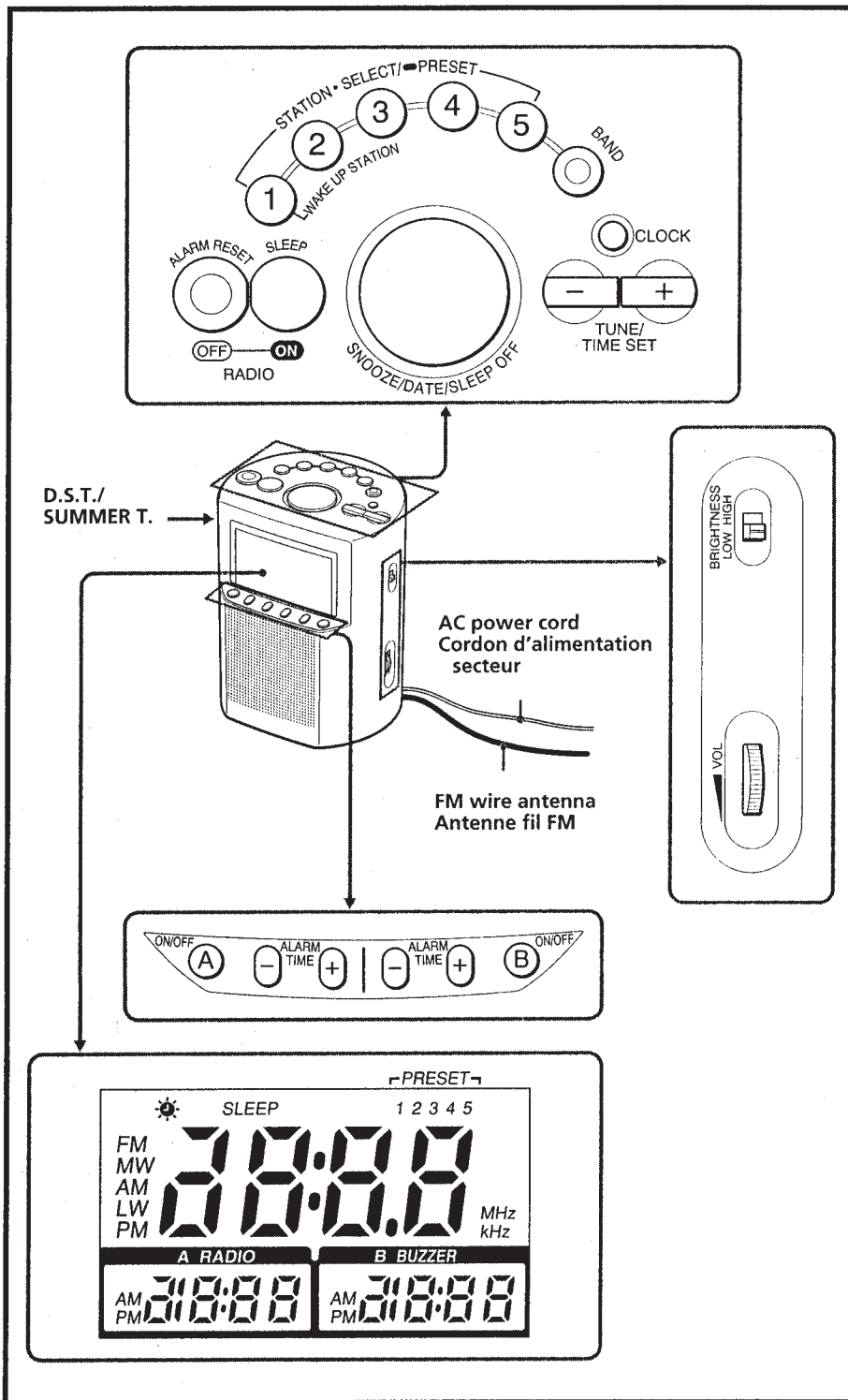

## Before You Begin

Thank you for choosing the Sony Dream Machine. The Dream Machine will give you many hours of reliable service and listening pleasure.

Before operating your unit, please read these instructions thoroughly and retain them for future reference.

The instructions here are for models ICF-C793 and ICF-C793L.

Their difference is shown below:

Model Number	ICF-C793	ICF-C793L
Band	FM/AM	FM/MW/LW

## Features

- Dual alarm FM/AM (ICF-C793) or FM/MW/LW (ICF-C793L) PLL (phase locked loop) synthesized clock radio.
- Triple display—main display, and two sub-displays for the alarms.
- LCD with backlight, and brightness adjustment for the backlight.
- Date button to display the year, month and date.
- Easy radio preset—with the pressing of a button.
- D.S.T. (Daylight Saving Time)—Summer time adjustment (one-hour skip function).
- 5 random station presets.
- Radio and buzzer alarms, as well as a snooze function.
- Self-powered backup that enables the current time and memory to be stored for about 30 minutes without batteries when the power supply is interrupted.

## Setting the Clock

- 1 Plug in the clock radio.  
The display will flash "AM 12:00" or "0:00".
  - 2 Press **CLOCK** for a few seconds.  
You will hear a beep and the year will start to flash in the display.
  - 3 Press **TUNE/TIME SET +** or **-** until the correct year appears in the display.
  - 4 Press **CLOCK** once.
  - 5 Repeat steps 3 and 4 to set the month, date, hour, and minute.  
After setting the minute, press **CLOCK** to start the counting of the seconds.
- To display the year and date, press **SNOOZE/DATE/SLEEP OFF** once for the date, and within 2 seconds press it again for the year. The display shows the date or year for a few seconds and then changes back to the current time.
  - To set the current time rapidly, hold down the **+** or **-** button.
  - The clock system varies depending on the model you own.  
12-hour system: "AM 12:00" = midnight  
24-hour system: "0:00" = midnight
  - In step 5, when you press **CLOCK** after the minute setting to activate the clock, the seconds start counting from zero.

### To change the display to the daylight saving time (summer time) indication

Press **D.S.T./SUMMER T.**

"☀" is displayed and the time indication changes to summer time.

To deactivate the summer time function, press **D.S.T./SUMMER T.** again.

## Operating the Radio

### Manual Tuning

- 1 Press **RADIO ON** to turn on the radio. The display shows the band and frequency for a few seconds and then changes back to the current time.
- 2 Press **BAND** repeatedly to select the desired band.
- 3 Use **TUNE/TIME SET +** or **-** to tune in to the desired station.
- 4 Adjust volume using **VOL**.

- To turn off the radio, press **RADIO OFF**.
- To improve reception
  - FM:** Extend the FM wire antenna fully to increase reception sensitivity.
  - AM(MW)/LW:** Rotate the unit horizontally for optimum reception. A ferrite bar is built in to the unit. Do not operate the unit over a steel desk or metal surface, as this may lead to interference of reception.
- To check the station being received, press the **TUNE/TIME SET +** or **-** button lightly. The display shows the band and frequency for a few seconds and then changes back to the current time.
- If the radio alarm comes on while the radio is on, the unit switches to the station on preset button 1 (the **WAKE UP STATION**).

### To set the brightness of the backlight

Set **BRIGHTNESS** for the display to **H** (high) or **L** (low) according to your preference.

### Preset Tuning

You can preset up to five stations for one-touch tuning; one for each of the preset buttons 1 to 5.

#### Presetting a station

Example: To preset AM 1260 kHz onto preset button 2.

- 1 Press **RADIO ON** to turn on the radio.
- 2 Tune in to the station you want to preset. (See "Manual Tuning".)
- 3 Hold down the desired **STATION•SELECT/PRESET** button (in this case, 2) until you hear two short beeps.



The display shows the frequency for a few seconds and then changes back to the current time.

For the radio alarm, preset the station to be used as the alarm onto preset button 1.

#### To change a preset station

Tune in manually to the station you want to store and hold down the preset button until you hear two short beeps. The previously stored station will be replaced by the new one.

#### Tuning in to a preset station

- 1 Press **RADIO ON** to turn on the radio.
- 2 Press the **STATION•SELECT/PRESET** button where the desired station is stored.
- 3 Adjust volume using **VOL**. After a few seconds, the display will return to the current time but the preset button number will remain.

## Setting the Alarm

Before setting the time for the radio and buzzer alarms, make sure you have set the current time (See "Setting the Clock"). For the radio alarm, make sure you have preset a radio station onto preset button 1 (See "Preset Tuning").

### To Set the Alarm Time

Press and hold down the **ALARM TIME +** or **-** button located directly under the **A RADIO** or **B BUZZER** display until the desired time appears.

### ALARM ON—

#### To Activate the Alarm

##### For the radio alarm:

Press the **ON/OFF A** button located directly under the **A RADIO** display. The **A RADIO** display lights up and shows the alarm time you have set.

##### For the buzzer alarm:

Press the **ON/OFF B** button located directly under the **B BUZZER** display. The **B BUZZER** display lights up and shows the alarm time you have set.

At the time set, the radio or buzzer alarm will sound for 60 minutes or until turned off.

#### Notes

- When the alarm comes on at the preset time, the alarm time in the display flashes.
- When the **ALARM TIME +** or **-** button is held down, the displayed time initially changes in one-minute steps, and after a few seconds, switches to five-minute steps.
- If you do not preset the radio/buzzer alarm time and activate the alarm, the alarm will sound at AM 12:00 or 0:00.
- For the buzzer alarm, the beeping of the alarm becomes more rapid after every few seconds in five progressive stages.

### ALARM OFF—

#### To Stop the Alarm

Press **ALARM RESET** to turn off the alarm.

The alarm will come on again at the same time the next day.

#### To Cancel the Alarm

For the radio alarm, press the **ON/OFF A** button to switch off the display.

For the buzzer alarm, press the **ON/OFF B** button to switch off the display.

#### Notes

- The alarm does not function unless you set the clock and activate the **A RADIO** or **B BUZZER** function.
- If both the radio and buzzer alarms are set for the same time, the radio alarm takes precedence.

### To Doze for a Few More Minutes

Press **SNOOZE/DATE/SLEEP OFF**.

The radio or buzzer turns off but will automatically come on again after about 8 minutes. You can repeat this process as many times as you like.

## Setting the Sleep Timer

You can enjoy falling asleep to the radio using the built-in sleep timer that turns off the radio automatically after a preset duration.

Press **SLEEP**.

The radio turns on. You can set the sleep timer to durations of 90, 60, 30, or 15 minutes. Every push changes the display as follows

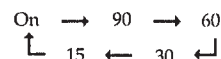

To turn off the radio before the preset time, press **SNOOZE/DATE/SLEEP OFF**.

### To Use Both Sleep Timer and Alarm

You can fall asleep to the radio and also be awakened by the radio or buzzer alarm at the preset time.

- 1 Set the alarm. (See "Setting the Alarm".)
- 2 Set the sleep timer. (See "Setting the Sleep Timer".)



## SECTION 3 DISASSEMBLY

**Note:** Follow the disassembly procedure in the numerical order given.

### CHASSIS ASSY

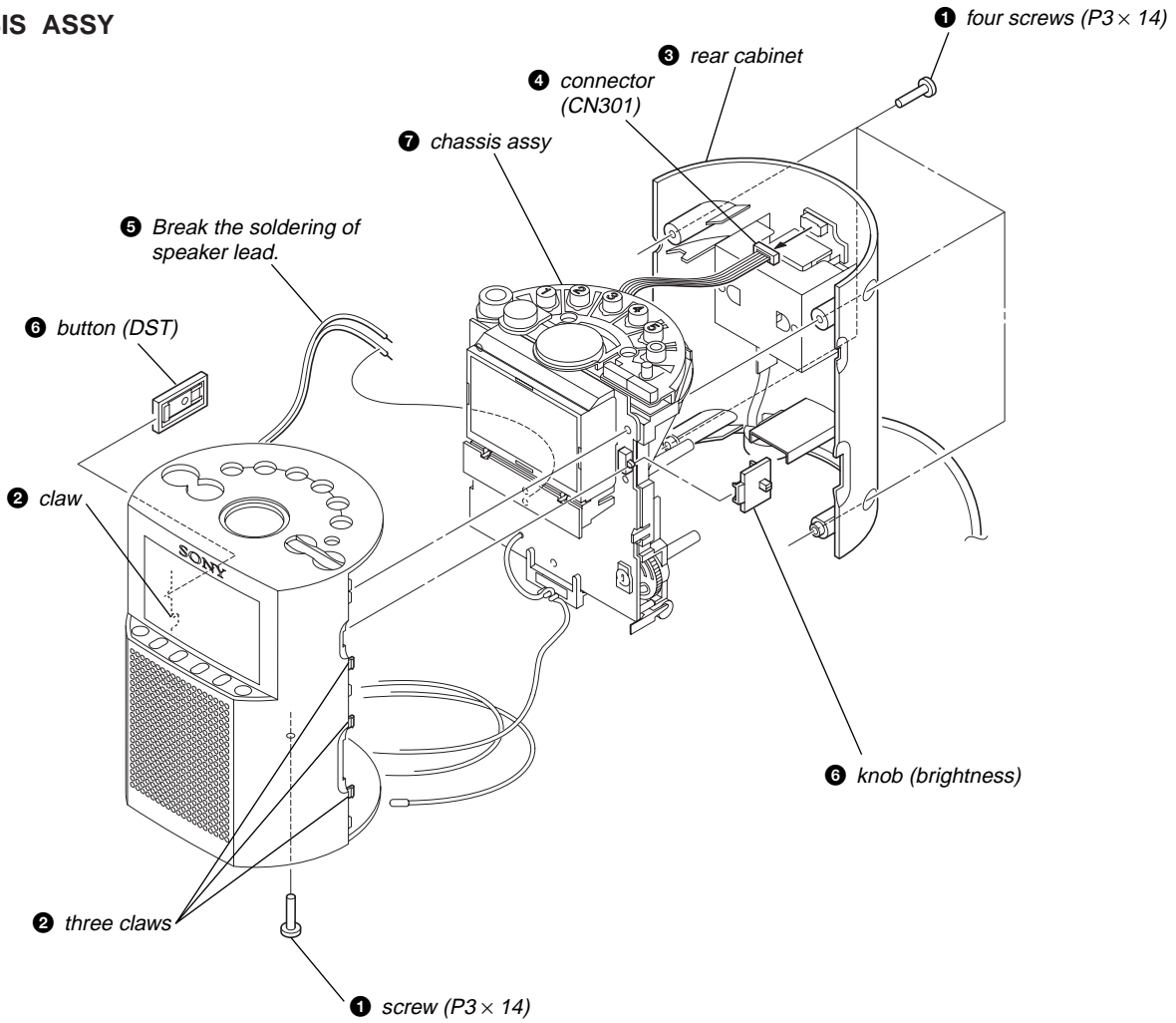

### POWER CORD SETTING

Set the power cord as illustrated below, then install the cabinet.

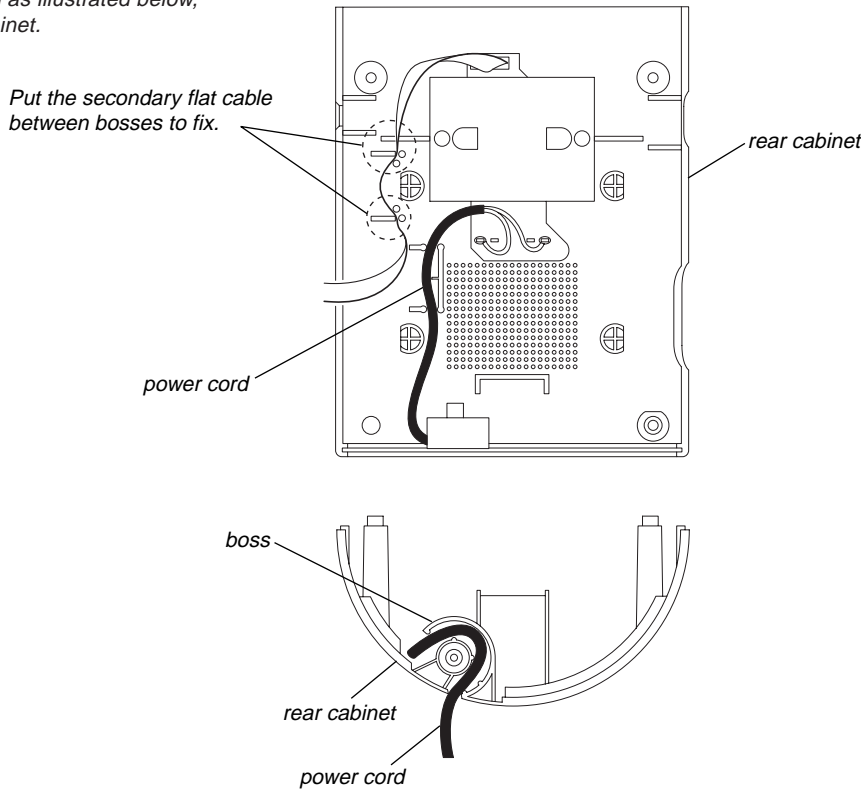

## SECTION 4 ELECTRICAL ADJUSTMENTS

0 dB = 1  $\mu$ V

### [FM]

#### Setting:

Band switch: FM

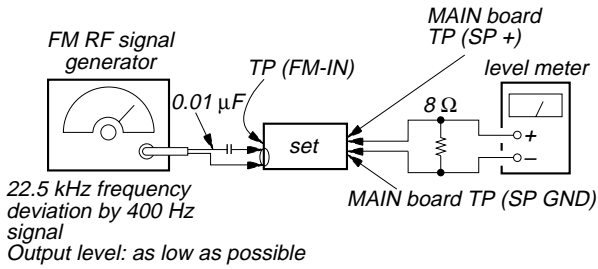

### [AM (MW/LW)\*]

\* AM : ICF-C793

MW/LW : ICF-C793L

#### Setting:

Band switch: AM (MW/LW)

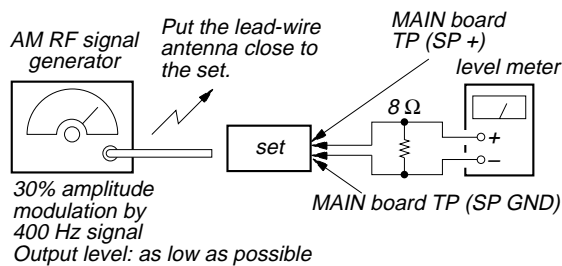

- Repeat the procedures in each adjustment several times, and the frequency coverage and tracking adjustments should be finally done by the trimmer capacitors.
- Remove FM antenna in FM adjustments.

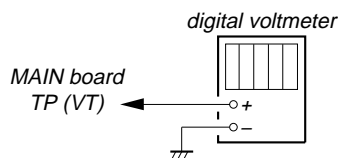

**Adjustment Location:** Main Board (See page 8)

### FM VCO VOLTAGE ADJUSTMENT

Adjustment Part	Frequency Display	Reading on Digital Voltmeter
L4	87.5 MHz	3 V $\pm$ 0.1V
Confirmation	108 MHz	Less than 11.8 V

### FM TRACKING ADJUSTMENT

Adjust for a maximum reading on level meter.

L3	87.5 MHz
TC3	108 MHz

### AM (MW) VCO VOLTAGE ADJUSTMENT

Adjustment Part	Frequency Display	Reading on Digital Voltmeter
L5	530 kHz (531kHz *1)	2.65 V $\pm$ 0.1V
Confirmation	1,710 kHz (1,602 kHz *1)	Less than 10 V (9.5 V *1)

### AM (MW) TRACKING ADJUSTMENT

Adjust for a maximum reading on level meter.

L1 (L1-1 *2)	580 kHz (621 kHz *1)
TC1	1,490 kHz (1,404 kHz *1)

### LW VCO VOLTAGE ADJUSTMENT \*2

Adjustment Part	Frequency Display	Reading on Digital Voltmeter
TC4	153 kHz	2.25 V $\pm$ 0.05V
Confirmation	279 kHz	Less than 9.5 V

### LW TRACKING ADJUSTMENT \*2

Adjust for a maximum reading on level meter.

L1-2	162 kHz
TC2	243 kHz

### AM IF ADJUSTMENT

Adjust for a maximum reading on level meter.

T1	450 kHz
----	---------

\*1) Except US, Canadian models

\*2) ICF-C793L

**Adjustment Location:**

**– MAIN BOARD (Component Side) –**

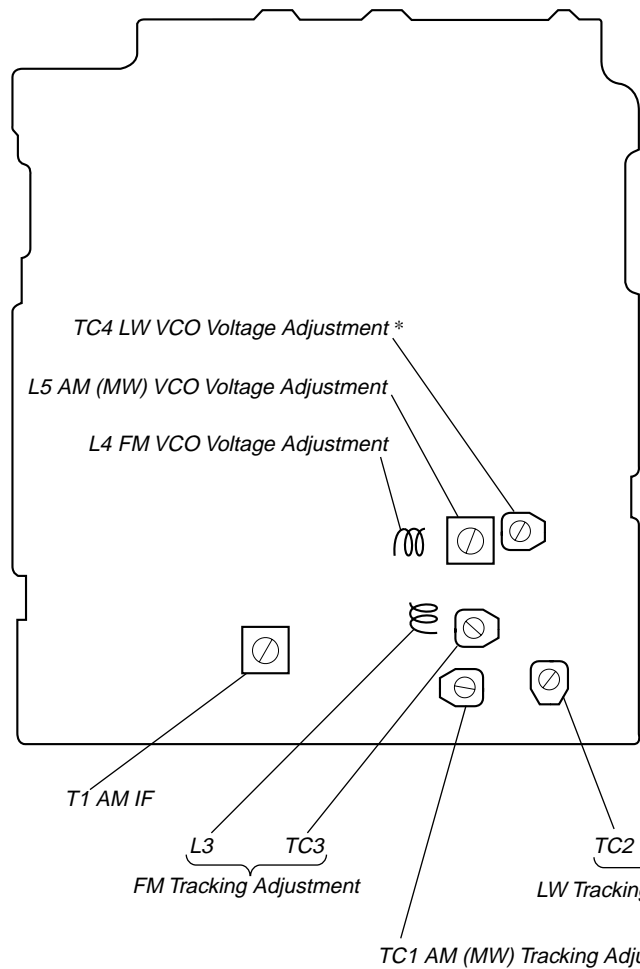

**– MAIN BOARD (Conductor Side) –**

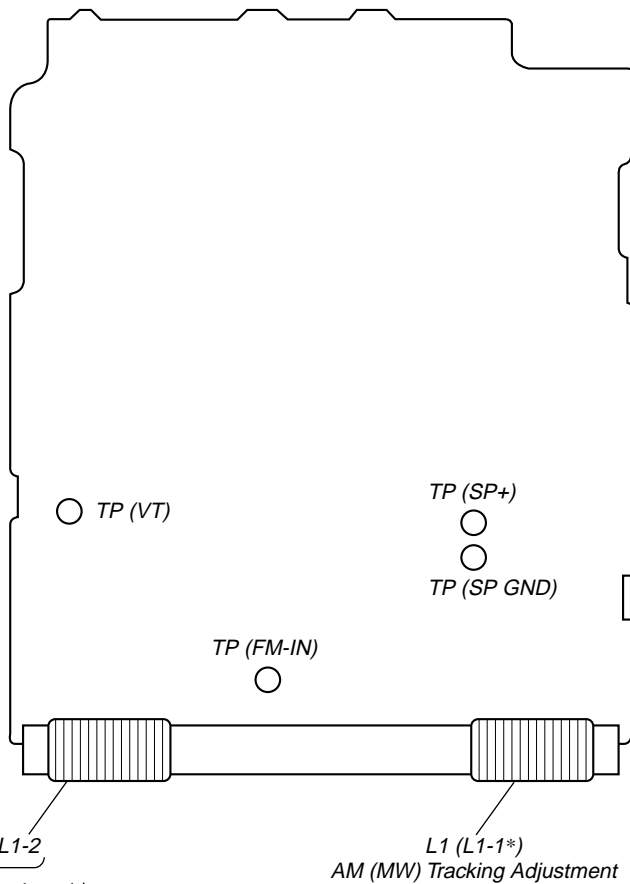

\*) ICF-C793L

SECTION 5  
DIAGRAMS

5-1. BLOCK DIAGRAM

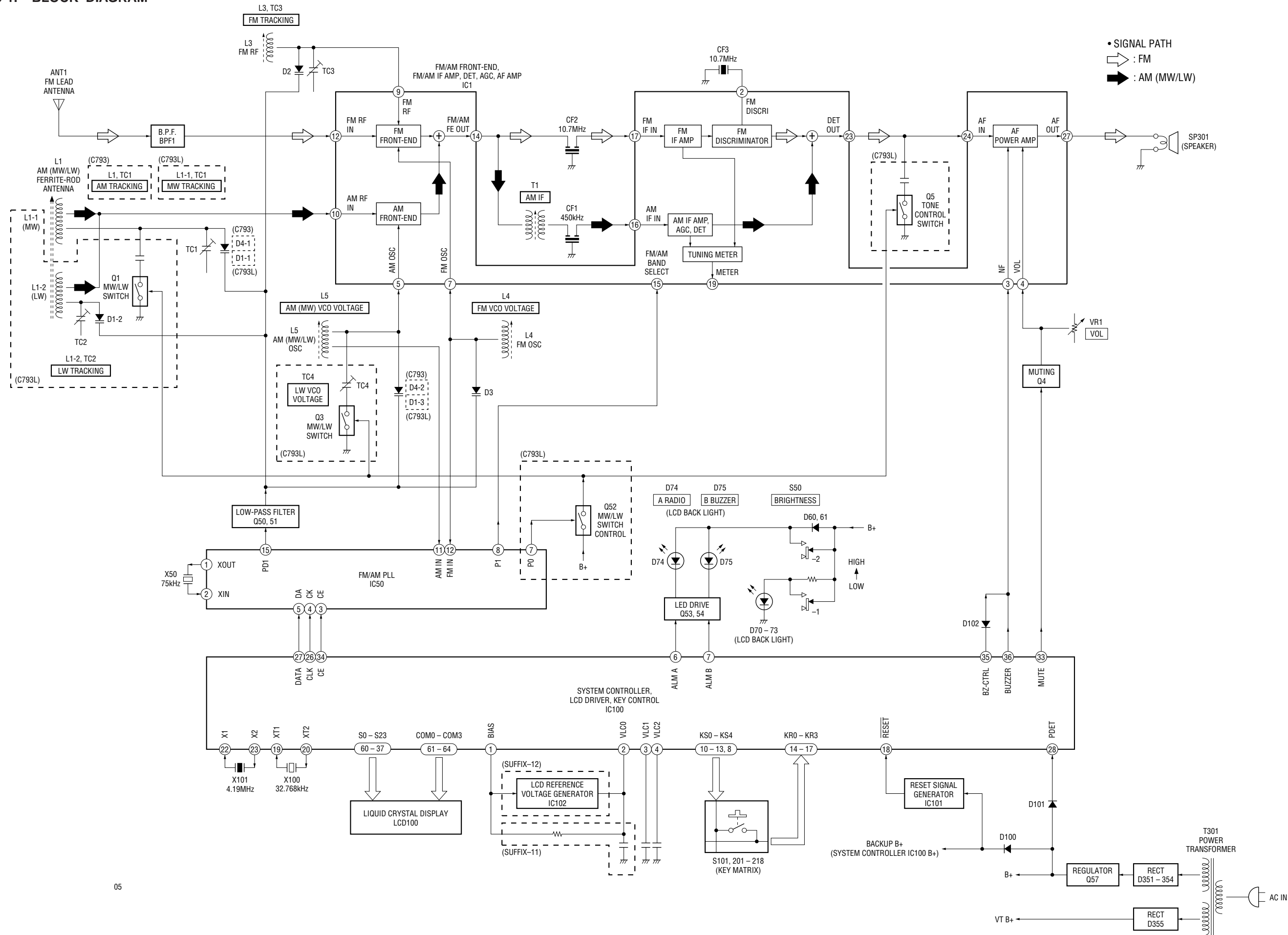

05

5-2. IC PIN FUNCTION DESCRIPTION

• MAIN BOARD IC100  $\mu$ PD753106GC-053-AB8 (SYSTEM CONTROLLER, LCD DRIVER, KEY CONTROL)

Pin No.	Pin Name	I/O	Description
1	BIAS	O	Liquid crystal display drive bias control output terminal
2 to 4	VLC0 to VLC2	—	Terminal for doubler circuit capacitor connection to develop liquid crystal display drive voltage
5	NC	O	Not used (open)
6	ALM A	O	LED drive signal output of the LCD back light LED (D74) "H" output at alarm A setting (LED on)
7	ALM B	O	LED drive signal output of the LCD back light LED (D75) "H" output at alarm B setting (LED on)
8	KS4	O	Key scan signal output of the key matrix (S101, S201 to S218)
9	VSS	—	Ground terminal
10 to 13	KS0 to KS3	O	Key scan signal output of the key matrix (S101, S201 to S218)
14 to 17	KR0 to KR3	I	Key return signal input of the key matrix (S101, S201 to S218)
18	RESET	I	System reset signal input from the reset signal generator (IC101) "L": reset "L" is input for several 100 msec after power on, then it changes to "H"
19	XT1	I	Sub system clock input terminal (32.768 kHz)
20	XT2	O	Sub system clock output terminal (32.768 kHz)
21	IC	—	Connected to power supply (+3.8V)
22	X1	I	Main system clock input terminal (4.19 MHz)
23	X2	O	Main system clock output terminal (4.19 MHz)
24	VDD	—	Power supply terminal (+3.8V)
25	NC	I	Not used (open)
26	CLK	O	PLL serial data transfer clock signal output to the FM/AM PLL (IC50)
27	DATA	O	PLL serial data output to the FM/AM PLL (IC50)
28	PDET	I	Power failure detection input terminal "L": power failure
29 to 31	PI0 to PI2	I	Destination setting terminal *1
32	TEST	I	Test mode input terminal "L": test mode Not used (open)
33	MUTE	O	Muting on/off control signal output terminal "L": muting on
34	CE	O	PLL serial chip enable signal output to the FM/AM PLL (IC50)
35	BZ-CTRL	O	Buzzer control signal output terminal "H" output at alarm B active
36	BUZZER	O	Beep sound (2 kHz) drive signal output to the CXA1019M (IC1)
37 to 60	S23 to S0	O	Segment drive signal output to the liquid crystal display (LCD100)
61 to 64	COM0 to COM3	O	Common drive signal output to the liquid crystal display (LCD100)

\*1

	ICF-C793			ICF-C793L	
	US, Canadian	AEP, Singapore	Australian	French	UK
PI0 (pin 29)	"H"	"H"	"H"	"H"	"L"
PI1 (pin 30)	"H"	"L"	"H"	"L"	"H"
PI2 (pin 31)	"H"	"H"	"L"	"L"	"H"

• IC Block Diagrams  
- MAIN board -

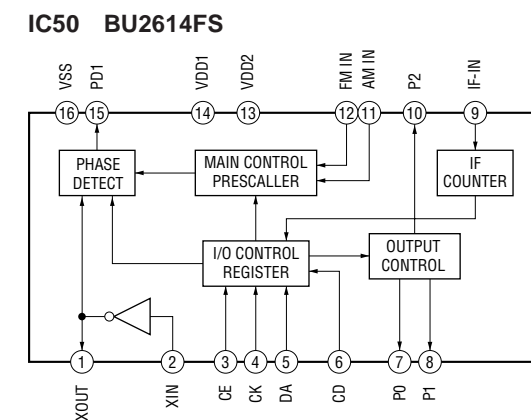
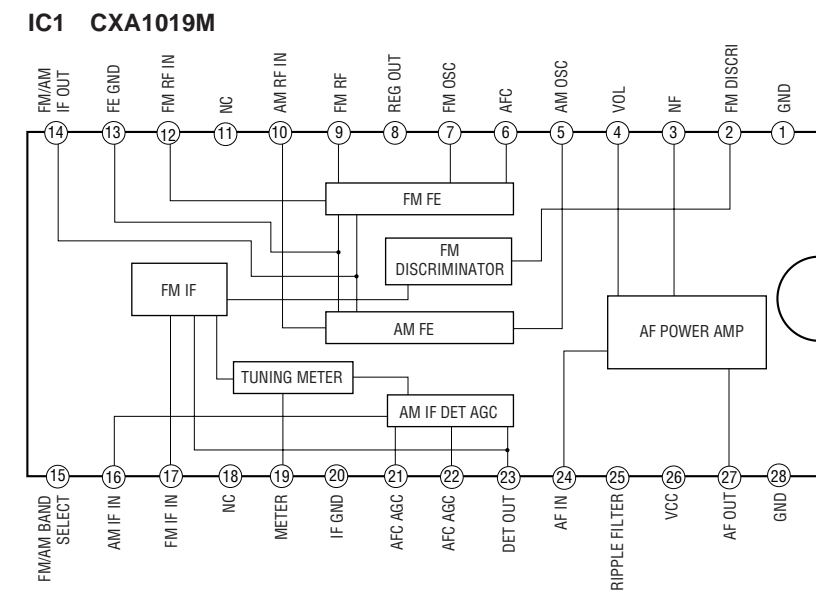

• Waveforms  
- MAIN board -

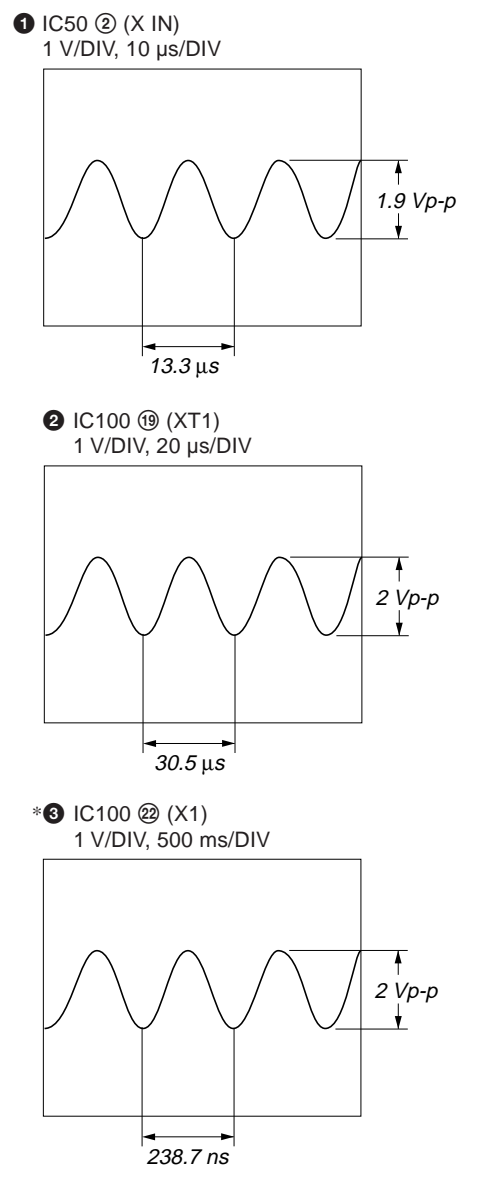

\*Note:  
• Press either  $\oplus$  or  $\ominus$  key when RADIO is being operated, oscillation will be given out for 250 ms.  
• Oscillation will be given out for 250 ms when the power is turned on.

**Note on Schematic Diagram:**  
• All capacitors are in  $\mu\text{F}$  unless otherwise noted.  $\text{pF}$ :  $\mu\text{F}$  50 WV or less are not indicated except for electrolytics and tantalums.  
• All resistors are in  $\Omega$  and  $1/4W$  or less unless otherwise specified.  
•  $\Delta$ : internal component.  
•  $\square$ : panel designation.

**Note:**  
The components identified by mark  $\Delta$  or dotted line with mark  $\Delta$  are critical for safety. Replace only with part number specified.

**Note:**  
Les composants identifiés par une marque  $\Delta$  sont critiques pour la sécurité. Ne les remplacer que par une pièce portant le numéro spécifié.

- $\oplus$  : B+ Line.
- $\ominus$  : adjustment for repair.
- Voltages and waveforms are dc with respect to ground under no-signal (detuned) conditions.
- no mark : FM
- ( ) : AM (MW/LW)
- Voltages are taken with a VOM (Input impedance 10 M $\Omega$ ). Voltage variations may be noted due to normal production tolerances.
- Waveforms are taken with an oscilloscope. Voltage variations may be noted due to normal production tolerances.
- Circled numbers refer to waveforms.

- Signal path.
- $\rightarrow$  : FM
- $\rightarrow$  : AM (MW/LW)
- Abbreviation
- AUS : Australian model
- CND : Canadian model
- FR : French model
- SP : Singapore model
- -11 : Suffix-11
- -12 : Suffix-12

5-3. SCHEMATIC DIAGRAM

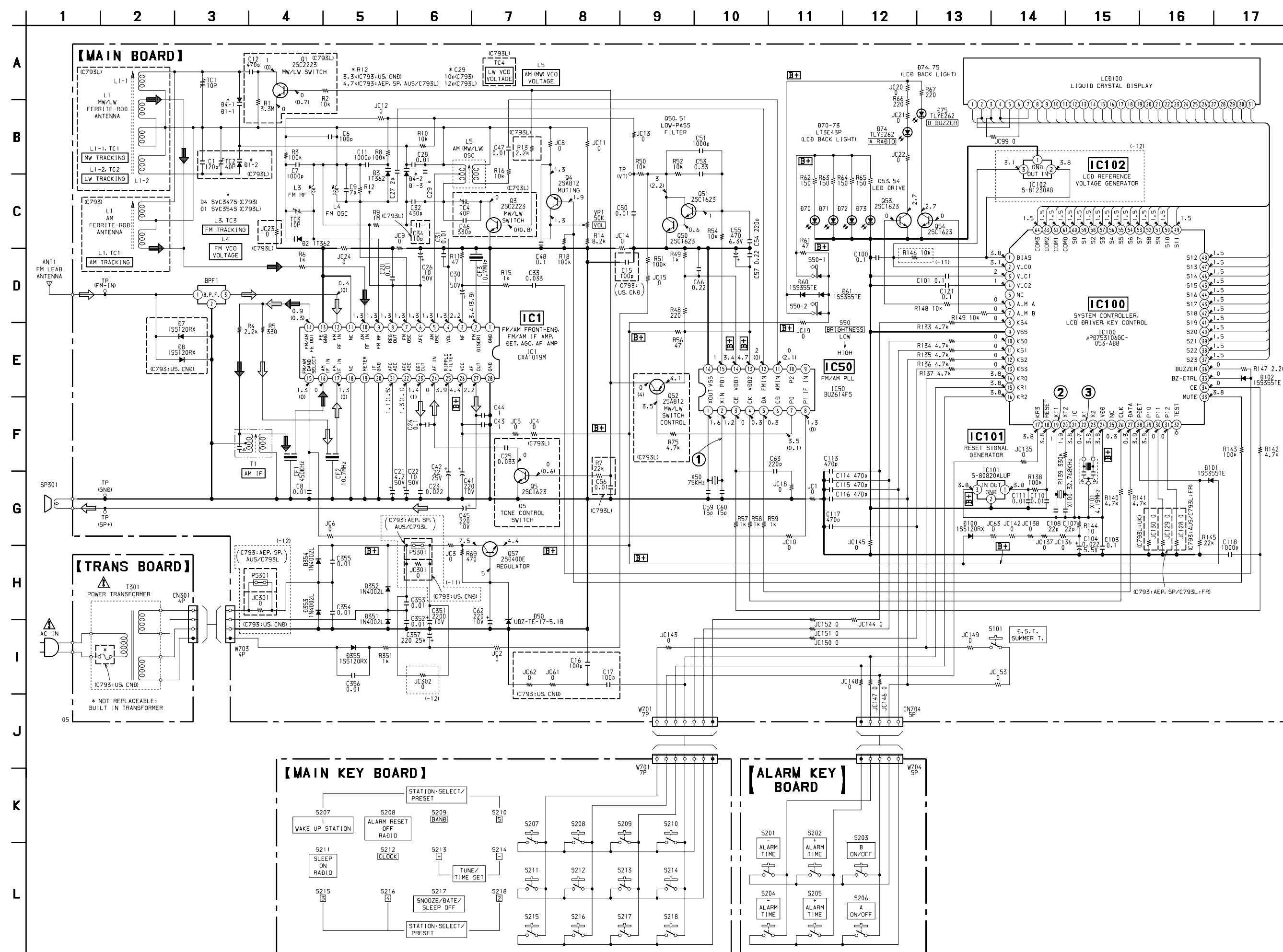



5-4. PRINTED WIRING BOARDS (SUFFIX-11)

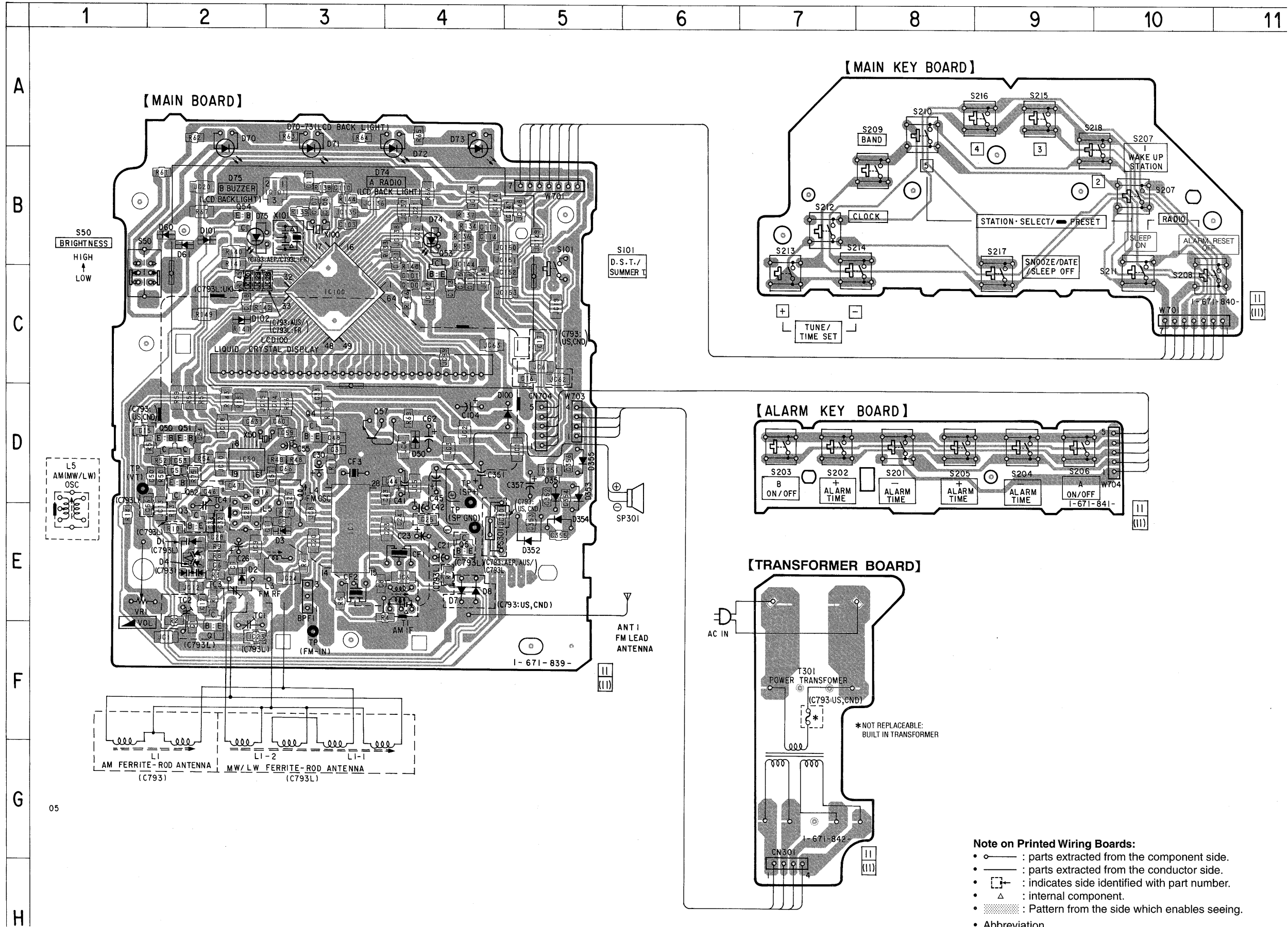

• Semiconductor Location

Ref. No.	Location
D1	E-2
D2	E-2
D3	E-3
D4	E-2
D7	E-4
D8	E-4
D50	D-4
D60	B-2
D61	B-2
D70	A-2
D71	A-3
D72	A-4
D73	A-4
D74	B-4
D75	B-2
D100	D-5
D101	B-2
D102	C-2
D351	D-5
D352	E-5
D353	D-5
D354	E-5
D355	D-5
IC1	E-3
IC50	D-2
IC100	C-3
IC101	B-3
Q1	F-2
Q3	D-2
Q4	D-3
Q5	E-4
Q50	D-2
Q51	D-2
Q52	D-2
Q53	C-4
Q54	B-2
Q57	D-3

**Note on Printed Wiring Boards:**

- : parts extracted from the component side.
- : parts extracted from the conductor side.
- : indicates side identified with part number.
- △ : internal component.
- ▨ : Pattern from the side which enables seeing.

**Abbreviation**

- AUS : Australian model
- CND : Canadian model
- FR : French model







(2) CHASSIS SECTION

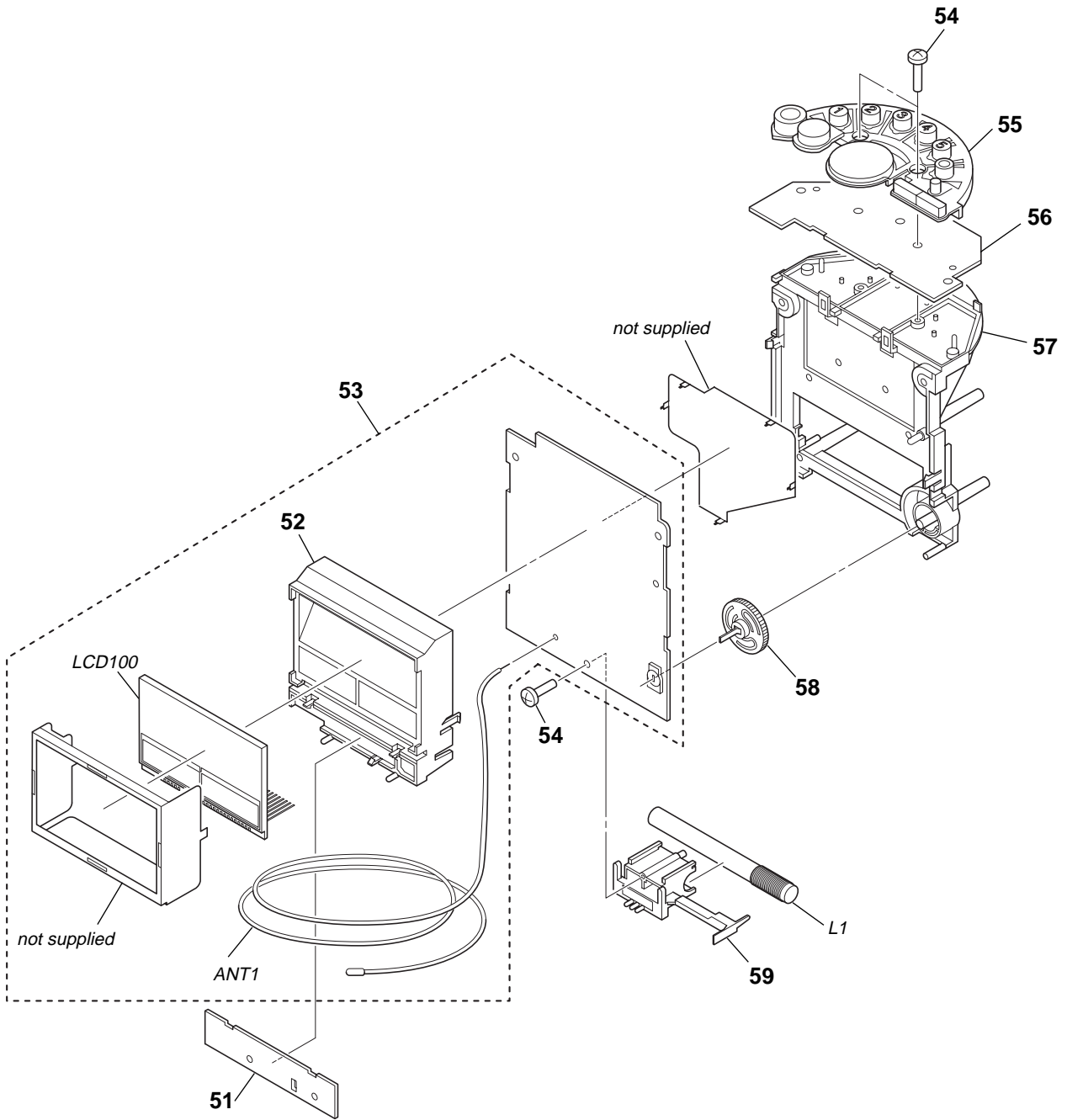

Ref. No.	Part No.	Description	Remark	Ref. No.	Part No.	Description	Remark
* 51	1-671-841-11	ALARM KEY BOARD		* 56	1-671-840-11	MAIN KEY BOARD	
52	3-032-464-01	HOLDER (LCD)		57	3-032-459-01	CHASSIS	
53	A-3663-208-A	MAIN BOARD, COMPLETE (C793: US, CND)		58	3-919-268-01	KNOB (VOL)	
53	A-3663-266-A	MAIN BOARD, COMPLETE (C793: AUS)		59	3-033-972-01	HOLDER, FERRITE-ROD ANTENNA	
53	A-3663-268-A	MAIN BOARD, COMPLETE (C793: AEP, SP)		L1	1-754-039-11	ANTENNA, FERRITE-ROD (AM) (C793)	
53	A-3663-272-A	MAIN BOARD, COMPLETE (C793L: FR)		L1	1-754-040-11	ANTENNA, FERRITE-ROD (LW/MW) (C793L)	
53	A-3663-275-A	MAIN BOARD, COMPLETE (C793L: UK)		LCD100	1-803-446-11	DISPLAY PANEL, LIQUID CRYSTAL	
54	7-685-649-79	SCREW +P 3X14 TYPE2 NON-SLIT		ANT1	1-501-907-21	ANTENNA, FM WIRE (FM LEAD ANTENNA)	
55	3-032-461-01	BUTTON (MAIN)					

# SECTION 7 ELECTRICAL PARTS LIST

**ALARM KEY**

**MAIN**

**NOTE:**

- Due to standardization, replacements in the parts list may be different from the parts specified in the diagrams or the components used on the set.
- -XX and -X mean standardized parts, so they may have some difference from the original one.
- RESISTORS  
All resistors are in ohms.  
METAL: Metal-film resistor.  
METAL OXIDE: Metal oxide-film resistor.  
F: nonflammable
- Abbreviation  
AUS : Australian model      -11 : Suffix-11  
CND : Canadian model      -12 : Suffix-12  
FR : French model  
SP : Singapore model

- Items marked “\*” are not stocked since they are seldom required for routine service. Some delay should be anticipated when ordering these items.
- SEMICONDUCTORS  
In each case, u:  $\mu$ , for example:  
uA. . :  $\mu$ A. .      uPA. . :  $\mu$ PA. .  
uPB. . :  $\mu$ PB. .      uPC. . :  $\mu$ PC. .  
uPD. . :  $\mu$ PD. .
- CAPACITORS  
uF:  $\mu$ F
- COILS  
uH:  $\mu$ H

The components identified by mark  $\Delta$  or dotted line with mark  $\Delta$  are critical for safety. Replace only with part number specified.

Les composants identifiés par une marque  $\Delta$  sont critiques pour la sécurité. Ne les remplacer que par une pièce portant le numéro spécifié.

When indicating parts by reference number, please include the board.

Ref. No.	Part No.	Description	Remark	Ref. No.	Part No.	Description	Remark
*	1-671-841-11	ALARM KEY BOARD *****		C21	1-126-963-11	ELECT      4.7uF      20%	50V
		< SWITCH >		C22	1-126-964-11	ELECT      10uF      20%	50V
S201	1-553-856-00	SWITCH, KEYBOARD (-, ALARM TIME)		C23	1-163-063-00	CERAMIC CHIP      0.022uF      10%	50V
S202	1-553-856-00	SWITCH, KEYBOARD (+, ALARM TIME)		C24	1-164-004-11	CERAMIC CHIP      0.1uF      10%	25V
S203	1-553-856-00	SWITCH, KEYBOARD (B, ON/OFF)		C25	1-163-989-11	CERAMIC CHIP      0.033uF      10%	25V (C793L)
S204	1-553-856-00	SWITCH, KEYBOARD (-, ALARM TIME)		C26	1-126-964-11	ELECT      10uF      20%	50V
S205	1-553-856-00	SWITCH, KEYBOARD (+, ALARM TIME)		C27	1-163-085-00	CERAMIC CHIP      2PF	50V
S206	1-553-856-00	SWITCH, KEYBOARD (A, ON/OFF)		C28	1-163-021-11	CERAMIC CHIP      0.01uF      10%	50V
*****				C29	1-163-227-11	CERAMIC CHIP      10PF      0.5PF	50V (C793)
	A-3663-208-A	MAIN BOARD, COMPLETE (C793: US, CND)		C29	1-163-229-11	CERAMIC CHIP      12PF      5%	50V (C793L)
	A-3663-266-A	MAIN BOARD, COMPLETE (C793: AUS)		C30	1-126-960-11	ELECT      1uF      20%	50V
	A-3663-268-A	MAIN BOARD, COMPLETE (C793: AEP, SP)		C31	1-163-021-11	CERAMIC CHIP      0.01uF      10%	50V
	A-3663-272-A	MAIN BOARD, COMPLETE (C793L: FR)		C32	1-163-132-00	CERAMIC CHIP      430PF      5%	50V
	A-3663-275-A	MAIN BOARD, COMPLETE (C793L: UK) *****		C33	1-163-989-11	CERAMIC CHIP      0.033uF      10%	25V
	3-032-464-01	HOLDER (LCD)		C34	1-163-227-11	CERAMIC CHIP      10PF      0.5PF	50V (C793L)
		< ANTENNA >		C41	1-126-934-11	ELECT      220uF      20%	10V
ANT1	1-501-907-21	ANTENNA, FM WIRE (FM LEAD ANTENNA)		C42	1-128-551-11	ELECT      22uF      20%	25V
		< BAND PASS FILTER >		C43	1-109-982-11	CERAMIC CHIP      1uF      10%	10V
BPF1	1-236-711-21	FILTER, BAND PASS		C44	1-109-982-11	CERAMIC CHIP      1uF      10%	10V
		< CAPACITOR >		C45	1-126-934-11	ELECT      220uF      20%	10V
C1	1-163-253-11	CERAMIC CHIP      120PF      5%	50V (C793L)	C46	1-163-263-11	CERAMIC CHIP      330PF      5%	50V (C793L)
C6	1-163-251-11	CERAMIC CHIP      100PF      5%	50V	C47	1-163-021-11	CERAMIC CHIP      0.01uF      10%	50V
C7	1-163-141-00	CERAMIC CHIP      0.001uF      5%	50V	C48	1-163-077-00	CERAMIC CHIP      0.1uF      10%	25V
C8	1-163-021-11	CERAMIC CHIP      0.01uF      10%	50V	C50	1-163-021-11	CERAMIC CHIP      0.01uF      10%	50V
C9	1-163-224-11	CERAMIC CHIP      7PF      0.25PF	50V	C51	1-163-009-11	CERAMIC CHIP      0.001uF      10%	50V
C11	1-163-141-00	CERAMIC CHIP      0.001uF      5%	50V	C53	1-110-501-11	CERAMIC CHIP      0.33uF      10%	16V
C12	1-163-133-00	CERAMIC CHIP      470PF      5%	50V (C793L)	C54	1-163-125-00	CERAMIC CHIP      220PF      5%	50V
C15	1-163-251-11	CERAMIC CHIP      100PF      5%	50V (C793: US, CND)	C55	1-126-935-11	ELECT      470uF      20%	6.3V
C16	1-163-251-11	CERAMIC CHIP      100PF      5%	50V (C793: US, CND)	C56	1-163-021-11	CERAMIC CHIP      0.01uF      10%	50V (C793L)
C17	1-163-251-11	CERAMIC CHIP      100PF      5%	50V (C793: US, CND)	C57	1-164-489-11	CERAMIC CHIP      0.22uF      10%	16V
C20	1-163-059-91	CERAMIC CHIP      0.01uF      10%	50V	C59	1-163-231-11	CERAMIC CHIP      15PF      5%	50V
				C60	1-163-231-11	CERAMIC CHIP      15PF      5%	50V
				C62	1-126-934-11	ELECT      220uF      20%	10V
				C63	1-163-125-00	CERAMIC CHIP      220PF      5%	50V
				C66	1-164-489-11	CERAMIC CHIP      0.22uF      10%	16V
				C100	1-163-038-00	CERAMIC CHIP      0.1uF	25V
				C101	1-163-038-00	CERAMIC CHIP      0.1uF	25V
				C103	1-164-004-11	CERAMIC CHIP      0.1uF      10%	25V

**MAIN**

Ref. No.	Part No.	Description	Remark	Ref. No.	Part No.	Description	Remark
C104	1-125-691-11	DOUBLE LAYER	0.022F	5.5V		< IC >	
C107	1-163-235-11	CERAMIC CHIP	22PF	5%	50V	IC1	8-752-050-16 IC CXA1019M
C108	1-163-235-11	CERAMIC CHIP	22PF	5%	50V	IC50	8-759-188-85 IC BU2614FS
C110	1-163-021-11	CERAMIC CHIP	0.01uF	10%	50V	IC100	8-759-571-48 IC uPD753106GC-053-AB8
C111	1-163-021-11	CERAMIC CHIP	0.01uF	10%	50V	IC101	8-759-580-04 IC S-80820ALUP-EAH-T2
C113	1-163-133-00	CERAMIC CHIP	470PF	5%	50V	IC102	8-759-939-41 IC S-81230AG-RB (-12)
C114	1-163-133-00	CERAMIC CHIP	470PF	5%	50V		< SHORT >
C115	1-163-133-00	CERAMIC CHIP	470PF	5%	50V	JC1	1-216-296-00 SHORT 0
C116	1-163-133-00	CERAMIC CHIP	470PF	5%	50V	JC2	1-216-296-00 SHORT 0
C117	1-163-133-00	CERAMIC CHIP	470PF	5%	50V	JC3	1-216-296-00 SHORT 0
C118	1-163-009-11	CERAMIC CHIP	0.001uF	10%	50V	JC4	1-216-296-00 SHORT 0
C121	1-163-038-00	CERAMIC CHIP	0.1uF		25V	JC5	1-216-296-00 SHORT 0
C351	1-126-927-11	ELECT	2200uF	20%	10V	JC6	1-216-296-00 SHORT 0
C352	1-163-021-11	CERAMIC CHIP	0.01uF	10%	50V	JC8	1-216-295-00 SHORT 0
C353	1-163-021-11	CERAMIC CHIP	0.01uF	10%	50V	JC9	1-216-296-00 SHORT 0
C354	1-163-021-11	CERAMIC CHIP	0.01uF	10%	50V	JC10	1-216-296-00 SHORT 0
C355	1-163-021-11	CERAMIC CHIP	0.01uF	10%	50V	JC11	1-216-296-00 SHORT 0
C356	1-163-021-11	CERAMIC CHIP	0.01uF	10%	50V	JC12	1-216-296-00 SHORT 0
C357	1-104-666-11	ELECT	220uF	20%	25V	JC13	1-216-296-00 SHORT 0
		< FILTER >				JC14	1-216-296-00 SHORT 0
* CF1	1-577-319-11	FILTER, CERAMIC (450kHz) (C793)				JC15	1-216-296-00 SHORT 0
CF1	1-578-677-21	FILTER, CRYSTAL (450kHz) (C793L)				JC18	1-216-296-00 SHORT 0
CF2	1-579-632-41	FILTER, CERAMIC (10.7MHz)				JC19	1-216-296-00 SHORT 0
CF3	1-579-632-41	FILTER, CERAMIC (10.7MHz)				JC20	1-216-296-00 SHORT 0
		< CONNECTOR >				JC21	1-216-296-00 SHORT 0
* CN704	1-568-271-11	SOCKET, CONNECTOR 5P				JC22	1-216-296-00 SHORT 0
		< DIODE >				JC23	1-216-295-00 SHORT 0 (C793L)
D1	8-719-057-59	DIODE SVC354S-TR (C793L)				JC24	1-216-296-00 SHORT 0
D2	8-713-100-11	DIODE 1T362				JC61	1-216-296-00 SHORT 0 (C793: US, CND)
D3	8-713-100-11	DIODE 1T362				JC62	1-216-296-00 SHORT 0 (C793: US, CND)
D4	8-719-072-59	DIODE SVC347S-TL (C793)				JC63	1-216-296-00 SHORT 0
D7	8-719-074-44	DIODE 1SS120RX (C793: US, CND)				JC99	1-216-295-00 SHORT 0
D8	8-719-074-44	DIODE 1SS120RX (C793: US, CND)				JC128	1-216-295-00 SHORT 0 (C793: AUS/C793L: FR)
D50	8-719-976-99	DIODE DTZ5.1B				JC129	1-216-295-00 SHORT 0 (C793: AEP, SP/C793L: FR)
D60	8-719-988-61	DIODE 1SS355TE-17				JC130	1-216-295-00 SHORT 0 (C793L: UK)
D61	8-719-988-61	DIODE 1SS355TE-17				JC135	1-216-296-00 SHORT 0
D70	8-719-950-41	LED GL-3EG43 (LCD BACK LIGHT)				JC136	1-216-296-00 SHORT 0
D71	8-719-950-41	LED GL-3EG43 (LCD BACK LIGHT)				JC137	1-216-296-00 SHORT 0
D72	8-719-950-41	LED GL-3EG43 (LCD BACK LIGHT)				JC138	1-216-296-00 SHORT 0
D73	8-719-950-41	LED GL-3EG43 (LCD BACK LIGHT)				JC142	1-216-296-00 SHORT 0
D74	8-719-075-78	LED TLYE262A (K51.SOY.P) (A RADIO, LCD BACK LIGHT)				JC143	1-216-296-00 SHORT 0
D75	8-719-075-78	LED TLYE262A (K51.SOY.P) (B BUZZER, LCD BACK LIGHT)				JC144	1-216-296-00 SHORT 0
D100	8-719-074-44	DIODE 1SS120RX				JC145	1-216-296-00 SHORT 0
D101	8-719-988-61	DIODE 1SS355TE-17				JC146	1-216-296-00 SHORT 0
D102	8-719-988-61	DIODE 1SS355TE-17				JC147	1-216-295-00 SHORT 0
D351	8-719-031-85	DIODE 1N4002L				JC148	1-216-296-00 SHORT 0
D352	8-719-031-85	DIODE 1N4002L				JC149	1-216-296-00 SHORT 0
D353	8-719-031-85	DIODE 1N4002L				JC150	1-216-296-00 SHORT 0
D354	8-719-031-85	DIODE 1N4002L				JC151	1-216-296-00 SHORT 0
D355	8-719-074-44	DIODE 1SS120RX				JC152	1-216-296-00 SHORT 0
						JC153	1-216-296-00 SHORT 0
						JC301	1-216-295-00 SHORT 0 (C793: US, CND)
						JC302	1-216-295-00 SHORT 0 (-12)
		< COIL >					
						L3	1-406-545-11 COIL, AIR-CORE

Ref. No.	Part No.	Description	Remark	Ref. No.	Part No.	Description	Remark
L4	1-406-545-11	COIL, AIR-CORE		R63	1-216-029-00	METAL CHIP 150 5%	1/10W
L5	1-406-485-11	COIL (OSC)		R64	1-216-029-00	METAL CHIP 150 5%	1/10W
		< LIQUID CRYSTAL DISPLAY >		R65	1-216-029-00	METAL CHIP 150 5%	1/10W
LCD100	1-803-446-11	DISPLAY PANEL, LIQUID CRYSTAL		R66	1-216-182-00	RES, CHIP 220 5%	1/8W
		< IC LINK >		R67	1-216-182-00	RES, CHIP 220 5%	1/8W
PS301	1-533-588-11	LINK, IC (C793: AEP, SP, AUS/C793L)		R69	1-216-041-00	METAL CHIP 470 5%	1/10W
		< TRANSISTOR >		R75	1-216-065-00	RES, CHIP 4.7K 5%	1/10W (C793L)
Q1	8-729-102-07	TRANSISTOR 2SC2223-F13 (C793L)		R133	1-216-065-00	RES, CHIP 4.7K 5%	1/10W
Q3	8-729-102-07	TRANSISTOR 2SC2223-F13 (C793L)		R134	1-216-065-00	RES, CHIP 4.7K 5%	1/10W
Q4	8-729-216-22	TRANSISTOR 2SA1162-G		R135	1-216-065-00	RES, CHIP 4.7K 5%	1/10W
Q5	8-729-120-28	TRANSISTOR 2SC1623-L5L6 (C793L)		R136	1-216-065-00	RES, CHIP 4.7K 5%	1/10W
Q50	8-729-120-28	TRANSISTOR 2SC1623-L5L6		R137	1-216-065-00	RES, CHIP 4.7K 5%	1/10W
Q51	8-729-120-28	TRANSISTOR 2SC1623-L5L6		R138	1-216-097-00	RES, CHIP 100K 5%	1/10W
Q52	8-729-216-22	TRANSISTOR 2SA1162-G (C793L)		R139	1-216-109-00	METAL CHIP 330K 5%	1/10W
Q53	8-729-120-28	TRANSISTOR 2SC1623-L5L6		R140	1-216-214-00	RES, CHIP 4.7K 5%	1/8W
Q54	8-729-120-28	TRANSISTOR 2SC1623-L5L6		R141	1-216-214-00	RES, CHIP 4.7K 5%	1/8W
Q57	8-729-840-00	TRANSISTOR 2SD400-E		R142	1-216-065-00	RES, CHIP 4.7K 5%	1/10W
		< RESISTOR >		R143	1-216-246-00	RES, CHIP 100K 5%	1/8W
R1	1-216-133-00	METAL CHIP 3.3M 5%	1/10W (C793L)	R144	1-216-001-00	METAL CHIP 10 5%	1/10W
R2	1-216-073-00	RES, CHIP 10K 5%	1/10W (C793L)	R145	1-216-081-00	METAL CHIP 22K 5%	1/10W
R3	1-216-097-00	RES, CHIP 100K 5%	1/10W	R146	1-216-073-00	METAL CHIP 10K 5%	1/10W (-11)
R4	1-216-057-00	METAL CHIP 2.2K 5%	1/10W	R147	1-216-057-00	METAL CHIP 2.2K 5%	1/10W
R5	1-216-037-00	METAL CHIP 330 5%	1/10W	R148	1-216-073-00	METAL CHIP 10K 5%	1/10W
R6	1-216-049-11	RES, CHIP 1K 5%	1/10W	R149	1-216-222-95	RES, CHIP 10K 10%	1/8W
R7	1-216-081-00	METAL CHIP 22K 5%	1/10W (C793L)	R351	1-216-198-00	RES, CHIP 1K 5%	1/8W
R8	1-216-097-00	RES, CHIP 100K 5%	1/10W			< SWITCH >	
R9	1-216-121-00	RES, CHIP 1M 5%	1/10W	S50	1-571-478-11	SWITCH, SLIDE (BRIGHTNESS)	
R10	1-216-073-00	METAL CHIP 10K 5%	1/10W	S101	1-554-088-00	SWITCH, KEY BOARD (D. S. T./SUMMER T.)	
R11	1-216-017-00	RES, CHIP 47 5%	1/10W			< TRANSFORMER >	
R12	1-216-061-00	METAL CHIP 3.3K 5%	1/10W (C793: US, CND)	T1	1-404-790-11	TRANSFORMER, IF	
R12	1-216-065-00	RES, CHIP 4.7K 5%	1/10W (C793: AEP, SP, AUS/C793L)			< VARIABLE CAPACITOR >	
R13	1-216-057-00	METAL CHIP 2.2K 5%	1/10W (C793L)	TC1	1-141-601-21	CAP, ADJ 10PF	
R14	1-216-071-00	METAL CHIP 8.2K 5%	1/10W	TC2	1-141-605-21	CAP, ADJ 40PF (C793L)	
R15	1-216-198-00	RES, CHIP 1K 5%	1/8W	TC3	1-141-601-21	CAP, ADJ 10PF	
R16	1-216-073-00	METAL CHIP 10K 5%	1/10W	TC4	1-141-605-21	CAP, ADJ 40PF (C793L)	
R18	1-216-097-00	RES, CHIP 100K 5%	1/10W			< VARIABLE RESISTOR >	
R48	1-216-033-00	METAL CHIP 220 5%	1/10W	VR1	1-228-790-00	RES, VAR, CARBON 50K (VOL)	
R49	1-216-049-11	RES, CHIP 1K 5%	1/10W			< VIBRATOR >	
R50	1-216-073-00	METAL CHIP 10K 5%	1/10W	X50	1-767-517-11	VIBRATOR, CRYSTAL (75kHz)	
R51	1-216-097-00	RES, CHIP 100K 5%	1/10W	X100	1-567-098-41	VIBRATOR, CRYSTAL (32.768kHz)	
R52	1-216-073-00	METAL CHIP 10K 5%	1/10W	X101	1-760-641-21	VIBRATOR, CERAMIC (4.19MHz)	
R54	1-216-073-00	METAL CHIP 10K 5%	1/10W	*****			
R56	1-216-166-00	RES, CHIP 47 5%	1/8W	*	1-671-840-11	MAIN KEY BOARD	*****
R57	1-216-198-00	RES, CHIP 1K 5%	1/8W			< SWITCH >	
R58	1-216-198-00	RES, CHIP 1K 5%	1/8W	S207	1-553-856-00	SWITCH, KEYBOARD (1, WAKE UP STATION)	
R59	1-216-198-00	RES, CHIP 1K 5%	1/8W	S208	1-553-856-00	SWITCH, KEYBOARD (ALARM RESET, RADIO OFF)	
R61	1-216-017-00	RES, CHIP 47 5%	1/10W	S209	1-553-856-00	SWITCH, KEYBOARD (BAND)	
R62	1-216-029-00	METAL CHIP 150 5%	1/10W	S210	1-553-856-00	SWITCH, KEYBOARD (5)	

# ICF-C793/C793L

## MAIN KEY

## TRANSFORMER

Ref. No.	Part No.	Description	Remark
S211	1-553-856-00	SWITCH, KEYBOARD (SLEEP, RADIO ON)	
S212	1-553-856-00	SWITCH, KEYBOARD (CLOCK)	
S213	1-553-856-00	SWITCH, KEYBOARD (+, TUNE/TIME SET)	
S214	1-553-856-00	SWITCH, KEYBOARD (-, TUNE/TIME SET)	
S215	1-553-856-00	SWITCH, KEYBOARD (3)	
S216	1-553-856-00	SWITCH, KEYBOARD (4)	
S217	1-553-856-00	SWITCH, KEYBOARD (SNOOZE/DATE/SLEEP OFF)	
S218	1-553-856-00	SWITCH, KEYBOARD (2)	
*****			
*	1-671-842-11	TRANSFORMER BOARD *****	
*	1-535-771-11	TERMINAL (C793: AEP, AUS/C793L)  < CONNECTOR >	
* CN301	1-564-706-11	PIN, CONNECTOR (SMALL TYPE) 4P  < TRANSFORMER >	
△ T301	1-433-600-11	TRANSFORMER, POWER (C793: US, CND)	
△ T301	1-433-601-11	TRANSFORMER, POWER (C793: AEP, SP, AUS/C793L)	
*****			
MISCELLANEOUS *****			
△ 10	1-555-795-00	CORD, POWER (C793: AEP, SP/C793L: FR)	
△ 10	1-696-572-21	CORD, POWER (C793L: UK)	
△ 10	1-783-817-11	CORD, POWER (C793: US, CND)	
△ 10	1-790-431-11	CORD, POWER (C793: AUS)	
L1	1-754-039-11	ANTENNA, FERRITE-ROD (AM) (C793)	
L1	1-754-040-11	ANTENNA, FERRITE-ROD (LW/MW) (C793L)	
SP301	1-504-748-21	SPEAKER (6.6cm)	

\*\*\*\*\*

### ACCESSORIES & PACKING MATERIALS \*\*\*\*\*

- 3-865-471-11 MANUAL, INSTRUCTION  
(ENGLISH, FRENCH, GERMAN, DUTCH)  
(C793: CND, AEP, SP, AUS/C793L)
- 3-865-471-21 MANUAL, INSTRUCTION (ENGLISH)  
(C793: US)
- 3-865-471-31 MANUAL, INSTRUCTION  
(ENGLISH, ITALIAN, SPANISH, PORTUGUESE)  
(C793: AEP/C793L: FR)
- 3-865-471-41 MANUAL, INSTRUCTION  
(ENGLISH, SWEDISH, DANISH, FINNISH)  
(C793: AEP)

<p>The components identified by mark △ or dotted line with mark △ are critical for safety. Replace only with part number specified.</p>	<p>Les composants identifiés par une marque △ sont critiques pour la sécurité. Ne les remplacer que par une pièce portant le numéro spécifié.</p>
-----------------------------------------------------------------------------------------------------------------------------------------	---------------------------------------------------------------------------------------------------------------------------------------------------