

# *Compact Disc Player*

---

Operating Instructions

COMPACT  
**disc**  
DIGITAL AUDIO  
~~CDP-X339ES~~  
CDP-X229ES

# Warning

To prevent fire or shock hazard, do not expose the unit to rain or moisture.

To avoid electrical shock, do not open the cabinet. Refer servicing to qualified personnel only.

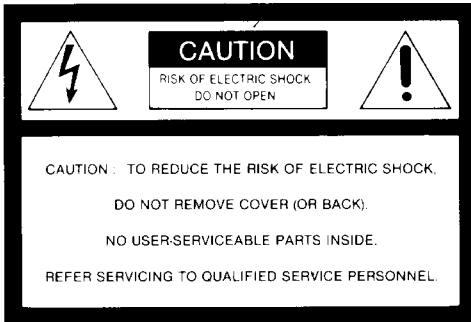

This symbol is intended to alert the user to the presence of uninsulated "dangerous voltage" within the product's enclosure that may be of sufficient magnitude to constitute a risk of electric shock to persons.



This symbol is intended to alert the user to the presence of important operating and maintenance (servicing) instructions in the literature accompanying the appliance.

## INFORMATION

This equipment has been tested and found to comply with the limits for a Class B digital device, pursuant to Part 15 of the FCC Rules. These limits are designed to provide reasonable protection against harmful interference in a residential installation. This equipment generates, uses, and can radiate radio frequency energy and, if not installed and used in accordance with the instructions, may cause harmful interference to radio communications. However, there is no guarantee that interference will not occur in a particular installation. If this equipment does cause harmful interference to radio or television reception, which can be determined by turning the equipment off and on, the user is encouraged to try to correct the interference by one or more of the following measures:

- Reorient or relocate the receiving antenna.
- Increase the separation between the equipment and receiver.
- Connect the equipment into an outlet on a circuit different from that to which the receiver is connected.
- Consult the dealer or an experienced radio/TV technician for help.

You are cautioned that any changes or modifications not expressly approved in this manual could void your authority to operate this equipment.

## Owner's Record

The model and serial numbers are located at the rear. Record these numbers in the spaces provided below. Refer to these numbers whenever you call upon your Sony dealer regarding this product.

Model No. \_\_\_\_\_ Serial No. \_\_\_\_\_

# Table of Contents

<b>Chapter 1 Introduction</b>	
Overview .....	4
Precautions .....	5
<b>Chapter 2 Getting Started</b>	
Unpacking .....	6
Hooking up the system .....	7
Identifying the parts .....	8
<b>Chapter 3 Basic Operation</b>	
Playing a disc—Continuous play .....	10
Playing in a random order—Shuffle play .....	14
Playing only the desired selections—Delete play .....	15
Playing the beginning of each selection—Music scan play .....	16
Playing repeatedly—Repeat play .....	17
Playing in a desired order—Program play .....	18
Fading in and fading out play—Fade in/fade out .....	20
<b>Chapter 4 Advanced Operation</b>	
Custom edit .....	21
Recording programmed selections on a tape .....	22
Designating the playing order of up to 6 discs—Multi-disc program .....	24
Designating the total playing time—Time edit/Just edit .....	26
Fading out at the desired time—Time fade .....	28
Locating the loudest portion of the disc—Peak search .....	29
Inserting a blank space between selections—Auto space .....	29
Custom files .....	30
Storing an optimum playback level for each disc —Level file .....	31
Assigning names to a disc—Disc memo .....	32
Indexing a disc—Custom index .....	34
Keeping the program in memory—Program bank .....	36
Keeping your desired selections in memory—Delete bank .....	37
Timer activated playing .....	38
<b>Chapter 5 Additional Information</b>	
Maintenance .....	39
Specifications .....	39
Troubleshooting guide .....	back cover

## Difference by Model

This instruction manual covers GDP-X229ES and CDP-X339ES. Their performance is identical except for the following:

- The CDP-X229ES is not supplied with side panels.
- The output terminal location on the rear panel of the CDP-X229ES and the CDP-X339ES is different.

The illustrations used in this manual are of the CDP-X229ES.

# Overview

## Enjoy listening in various playing modes

You can select playing modes among the following:

- Continuous play (page 10) – The entire disc is played once.
- Shuffle play (page 14) – Selections are played in a random order.
- Delete play (page 15) – Selections of your choice are played in the order you desire.
- Repeat play (page 17) – Selections or portions are played repeatedly.
- Program play (page 18) – Selections are played in your desired order.

## Editing your own tapes

- You can start to play from the immediate beginning of a selection. – Auto Cue (page 13)
- You can fade in or out the play when making your own tape recording. – Fade in/Fade out (page 20)
- CUSTOM EDIT function
  - You can program a pause separately on side A and B. – Pause program (page 22)
  - You can confirm the total playing time while choosing the selections to be programmed. – Program edit (page 22)
  - You can designate the playing order of up to 6 discs. – Multi-disc program (page 24)
  - The player can program selections automatically to fit in a desired duration. – Time edit/Just edit (page 26)
  - You can stop the play, fading out at the time desired. – Time fade (page 28)
  - The loudest portion of the disc will be determined and played repeatedly. – Peak search (page 29)

## You can play a beginning of each selection

You can check the selections by scanning the beginning of each selection in the disc. – Music scan play (page 16)

## Making your disc custom-made – CUSTOM FILE function

- You can store the optimum playback level of each disc in the player's memory. – Level file (page 31)
- You can assign a name to a disc, such as the title of the disc or the date of purchase. – Disc memo (page 32)
- You can assign your own index point to any desired position on a disc. – Custom index (page 34)
- You can store the programmed playing order for a disc. – Program bank (page 36)
- You can keep your undesired selections in memory – Delete bank (page 37)

## You can make 3-second blanks between selections

The blank space enables you to locate selections when using a tape deck with the automatic selection search function. – Auto space (page 29)

## Easy-to-see display

The selection number, the playing time, the remaining time are displayed by pressing the TIME/MEMO button.

In addition, you can change the desired display information by selecting three patterns. Adjusting the brightness of the display by selecting three patterns. (page 11)

# Precautions

## On safety

- Operate the unit only on 120 V AC, 60 Hz.
- Should any solid or liquid object enter the cabinet, unplug the player and have it checked by qualified personnel before operating it any further.
- Unplug the player from the wall outlet if it is not to be used for an extended period of time.  
To disconnect a cord, pull it out by the plug. Never pull the cord itself. The unit is not disconnected from the AC power source (mains) as long as it is connected to the wall outlet, even if the unit itself has been turned off.
- AC power cord must be changed only at the qualified service shop.
- Do not disassemble the cabinet. The laser beam used in this player is harmful to the eyes when uncovered. Refer servicing to qualified personnel only.

## On operation

- When turning off the power, wait until "NO DISC" message appears after a disc has been removed and the tray has been closed. Especially, this must be practiced when the player is to be transported.
- Remove the disc from the tray after playing it, if the player will not be used for any length of time. Do not transport the player with a disc in place.
- When the disc tray is in the open position, do not press down on it strongly, or place heavy objects on it.
- Do not turn up the volume while listening to a portion with very low level inputs or no audio signals. If you do, the speakers may be damaged when a peak level portion is played.

## On disc tray

- If the disc tray does not close properly and slides out again, reinsert the disc.
- Be careful not to pinch your fingers between the tray and the player.
- Always keep the tray closed when not using the player to keep dust or dirt from entering the optical system of the player.
- If the player does not operate, press the  OPEN/CLOSE button and reinsert the disc.
- Insert only one disc at a time.
- Make sure the disc is placed properly in the tray. Incorrect positioning may result in permanent damage to the disc.

## On moisture condensation

If the player is brought directly from a cold to a warm location, or is placed in a very damp room, moisture may condense on the lens inside the player. Should this occur, the player will not operate. In this case, remove the disc and leave the player turned on for about an hour until the moisture evaporates.

## Notes on handling discs

- To keep the disc clean, handle the disc by its edge. Do not touch the surface.



- Do not stick paper or tape on the disc.

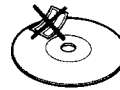

- Do not expose the disc to direct sunlight or heat sources such as hot air ducts, or leave it in a car parked in direct sunlight as there can be a considerable rise in the temperature.
- After playing, store the disc in its case.

If you have any questions or problems concerning your player, please contact your nearest Sony dealer.

## Customer for the U.S.A.

For detailed safety precautions, see the leaflet "IMPORTANT SAFEGUARDS".

# Unpacking

## Choosing a Good Location

- Place the player in a location with adequate air circulation to prevent internal heat build up in the player.
- Do not place the player on a soft surface, such as a rug that would block the ventilation holes on the bottom.
- Do not install the player:
  - near heat sources such as radiators or air ducts.
  - in a place subject to direct sunlight, excessive dust, mechanical vibration or shock.

## Checking the Supplied Accessories

Make sure that all supplied accessories are included with your player. This manual and the following items are included with your CDP-X339ES/CDP-X229ES.

- Audio connecting cords (1)
- Wireless remote commander RM-D991 (1)
- Sony SUM-3 (NS) batteries (2)

## Note on Packing Material

Before playing this player for the first time, be sure to remove the packing material from the disc compartment.

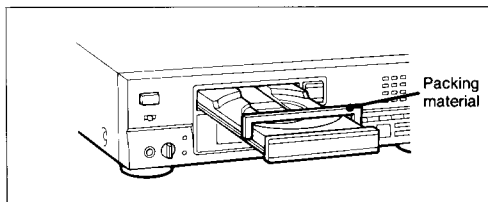

## Inserting the Batteries into the Remote Commander

**1** Open the cover.

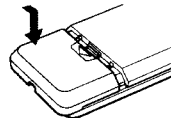

**2** Insert two size AA(R6) batteries with correct polarity.

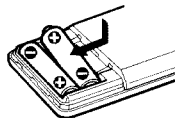

### Battery life

- About half a year of normal operation can be expected when using the Sony SUM-3(NS) batteries.
- When the batteries are run down, the remote commander will not operate the player. In this case, replace both batteries with new ones.

### Notes on the remote control operation

- Avoid exposing the remote sensor to direct sunlight or lighting apparatus. Such exposure can cause a malfunction.
- To avoid damage caused by battery leakage and corrosion, remove the batteries when the commander will not be used for a long time.

### Conventions



This symbol shown in the manual headings indicates a function operated only from the remote commander.



This symbol shown in the manual headings indicated a function operated only on the main player.

## Detaching the Side Panels

### For the model with the side panels which are detachable (CDP-X339ES only)

After removing the screws, secure the cabinet with the supplied lock screws (M4×6). Do not use the longer screws.

For safety, before doing this, be sure to disconnect the AC power cord from the AC outlet.

# Hooking Up the System

You can connect the player with analog or digital signal depending on your amplifier or D/A converter.

## Before you begin, remember the following:

- Turn off the power of each unit before making connections.
- Connect the AC power cord last.
- Be sure to insert the plugs firmly into the jacks. Loose connection may cause hum and noise.
- Leave a little slack in the connecting cord to allow for inadvertent shock or vibration.
- Cord plugs and jacks are color coded: Red plugs and jacks are for the right channel (R) and white ones for the left channel (L).

## Connecting an Amplifier Directly

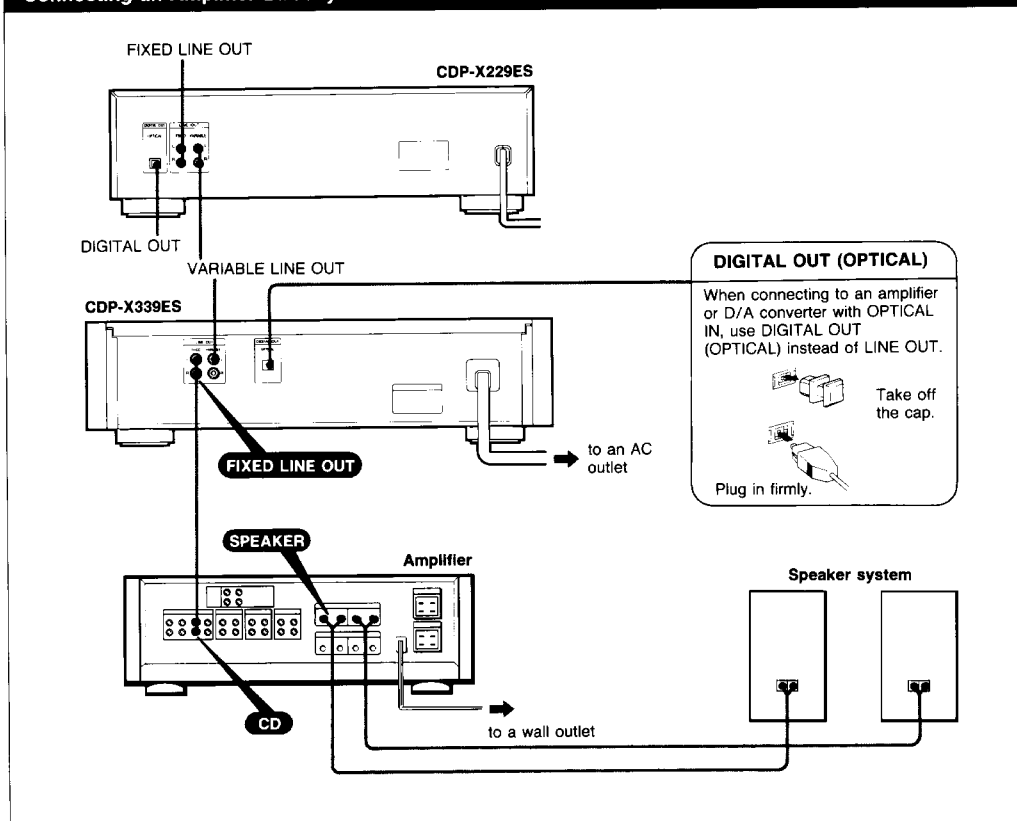

### Note on DIGITAL OUT (OPTICAL)

When connecting with DIGITAL OUT (OPTICAL), use the POC-15 audio optical connecting cord (not supplied). Please note that when the digital out is connected, fade out, fade in, time fade and level file functions cannot be used.

### Note on LINE OUT

**FIXED:** The output level is fixed.

**VARIABLE:** The output level can be adjusted with the LINE OUT/PHONE LEVEL or LINE OUT LEVEL on the remote commander.

- Connect your system to the VARIABLE output when using level file.
- If the LINE OUT/PHONE LEVEL is adjusted while recording, the recording level be changed even when it is preset on the tape deck.

# Identifying the Parts

## Front Panel

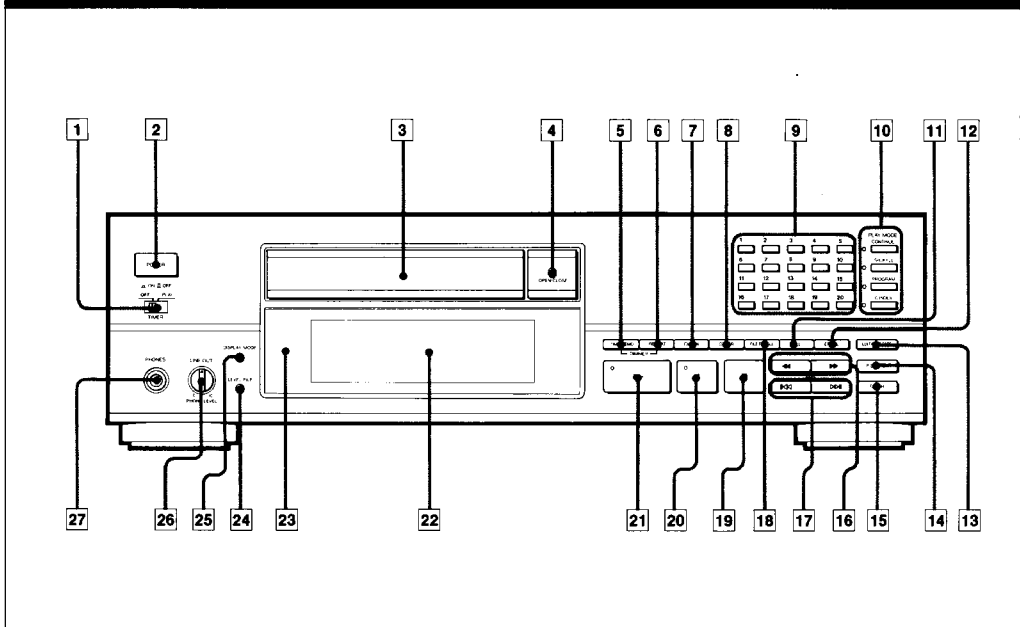

Refer to the pages indicated in ( ) for details.

- |                                                                                                                                                                                                                                                                                                                                                                                                                                                                                                                                                                                                                                                                                                                                                              |                                                                                                                                                                                                                                                                                                                                                                                                                                                                                                                                                                                                                                                                                              |
|--------------------------------------------------------------------------------------------------------------------------------------------------------------------------------------------------------------------------------------------------------------------------------------------------------------------------------------------------------------------------------------------------------------------------------------------------------------------------------------------------------------------------------------------------------------------------------------------------------------------------------------------------------------------------------------------------------------------------------------------------------------|----------------------------------------------------------------------------------------------------------------------------------------------------------------------------------------------------------------------------------------------------------------------------------------------------------------------------------------------------------------------------------------------------------------------------------------------------------------------------------------------------------------------------------------------------------------------------------------------------------------------------------------------------------------------------------------------|
| <ul style="list-style-type: none"> <li>1 TIMER switch (page 38)</li> <li>2 POWER switch (page 10)</li> <li>3 Disc tray (page 10)</li> <li>4 ▲ OPEN/CLOSE button (page 10)</li> <li>5 TIME/MEMO button (page 11)</li> <li>6 REPEAT button (page 17)</li> <li>7 CHECK (program check) button (pages 18 and 23)</li> <li>8 CLEAR (program clear) button (pages 18 and 22)</li> <li>9 Numeric buttons (page 12)</li> <li>10 PLAY MODE buttons<br/>CONTINUE button and indicator (page 10)<br/>SHUFFLE button and indicator (pages 14 and 15)<br/>PROGRAM button and indicator (pages 18 and 22)<br/>C.(custom) INDEX button and indicator (page 34)</li> <li>11 FILE (custom file) button (page 30)</li> <li>12 ERASE (memory erase) button (page 30)</li> </ul> | <ul style="list-style-type: none"> <li>13 EDIT/TIME FADE button (pages 26 and 28)</li> <li>14 P.(peak) SEARCH button (page 29)</li> <li>15 FADER (fade in/fade out) button (page 20)</li> <li>16 ◀▶▶▶ (manual search) buttons (page 12)</li> <li>17 ◀◀▶▶▶ AMS* buttons (page 12)</li> <li>18 FILE RECALL button (page 31)</li> <li>19 ■ (stop) button (page 10)</li> <li>20    (pause) button (page 10)</li> <li>21 ▶▶ (play) button (page 10)</li> <li>22 Display window (page 11)</li> <li>23 Remote sensor</li> <li>24 LEVEL FILE button (page 31)</li> <li>25 DISPLAY MODE button (page 11)</li> <li>26 LINE OUT/PHONE LEVEL control (pages 7 and 10)</li> <li>27 PHONES jack</li> </ul> |
|--------------------------------------------------------------------------------------------------------------------------------------------------------------------------------------------------------------------------------------------------------------------------------------------------------------------------------------------------------------------------------------------------------------------------------------------------------------------------------------------------------------------------------------------------------------------------------------------------------------------------------------------------------------------------------------------------------------------------------------------------------------|----------------------------------------------------------------------------------------------------------------------------------------------------------------------------------------------------------------------------------------------------------------------------------------------------------------------------------------------------------------------------------------------------------------------------------------------------------------------------------------------------------------------------------------------------------------------------------------------------------------------------------------------------------------------------------------------|

\* AMS is the abbreviation of Automatic Music Sensor.



## Remote Commander

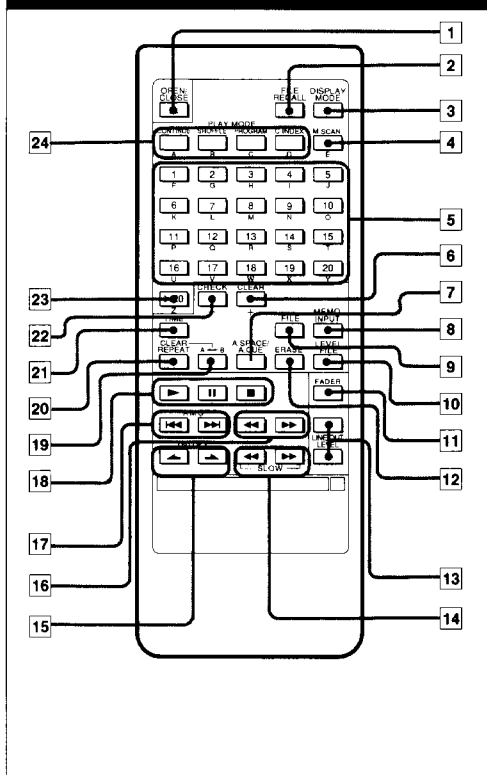

Refer to the pages indicated in ( ) for details.

- 1 OPEN/CLOSE button (page 10)
- 2 FILE RECALL button (page 31)
- 3 DISPLAY MODE button (page 11)
- 4 M.(music) SCAN button (page 16)
- 5 Numeric buttons (page 12)
- 6 CLEAR button (pages 18 and 22)
- 7 A.SPACE (auto space)/A.CUE (auto cue) button (pages 13 and 29)
- 8 MEMO INPUT button (page 32)
- 9 FILE (custom file) button (page 30)
- 10 LEVEL FILE button (page 31)
- 11 FADER (fade in/fade out) button (page 20)
- 12 ERASE button (page 30)
- 13 LINE OUT LEVEL (line out/headphone level) buttons (pages 7 and 10)
- 14 SLOW (low speed manual search) buttons (page 12)
- 15 INDEX buttons (pages 12 and 35)
- 16 (manual search) buttons (page 12)
- 17 AMS buttons (page 12)
- 18 (stop) button (page 10)
- 18 (pause) button (page 10)
- 18 (play) button (page 10)
- 19 A ↔ B repeat button (page 17)
- 20 REPEAT button (repeat/A ↔ B repeat clear) button (page 17)
- 21 TIME button (page 11)
- 22 CHECK button (pages 18 and 23)
- 23 >20 (over 20) button (page 12)
- 24 PLAY MODE buttons
  - CONTINUE button (page 10)
  - SHUFFLE button (pages 14 and 15)
  - PROGRAM button (pages 18 and 22)
  - C.(custom) INDEX button (page 34)

Buttons with orange letters (A, B, C, ..... ) are for entering a disc memo (page 32).

# Playing a Disc - Continuous Play

In the continuous play mode, you can play the first selection or desired selection on your disc.

Before playing a disc, turn on the amplifier and set the input selector to the CD player position.

## Playing the First Selection

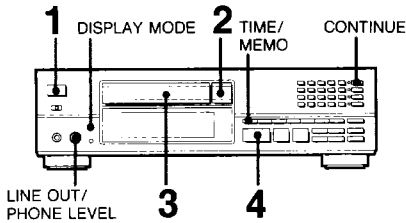

### 1 Press POWER.

If the indicator on the left side of the CONTINUE button does not light up, press CONTINUE.

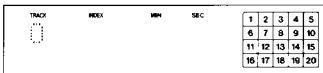

### 2 Press .



### 3 Place a disc with the printed side up on the tray.

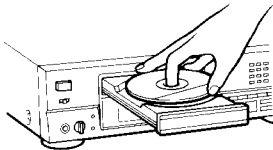

### 4 Press .

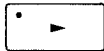

The disc tray closes to start playing the first selection.

### To stop play

To stop for a moment during play, press .

Press  or  to resume play.

To stop play, press .

To stop play and open the tray, press .

### To control the volume

When you use VARIABLE, adjust the volume with LINE OUT/PHONE LEVEL of the player or LINE OUT LEVEL of the remote commander. Press + of the remote commander to turn up the volume and press - to turn down the volume. When you press + or -, LINE OUT/PHONE LEVEL of the player rotates automatically.

### When listening with headphones

Connect the headphones and adjust the volume with LINE OUT/PHONE LEVEL or LINE OUT LEVEL of the remote commander.

### To play a 8 cm (3-inch) CD

Place it on the inner circle of the tray. If the disc is provided with an adaptor, first remove it. Do not put a normal CD (12 cm/5-inch) on to of a 8 cm CD.

### Note on the TIMER switch

Leave the TIMER switch off when you are not using timer activated play. (For further details, refer to page 38.)

### What is this indication?

-NO DISC-

This indication appears when the tray is empty. The indication can be changed to a customized indication. (page 32).

## Information Display

### Checking the total number of selections and total play time

There are two ways.

- Place your disc on the tray and then either press  to automatically close the tray or manually close it.
- Press TIME/MEMO (or TIME on the remote commander) during stop.

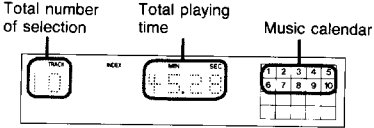

If disc contains more than 20 selections

▶ appears in the display window behind 20 on the music calendar.

### Checking the remaining playing time

Each time you press TIME/MEMO (or TIME on the remote commander) during play, the display changes to give you the following information.

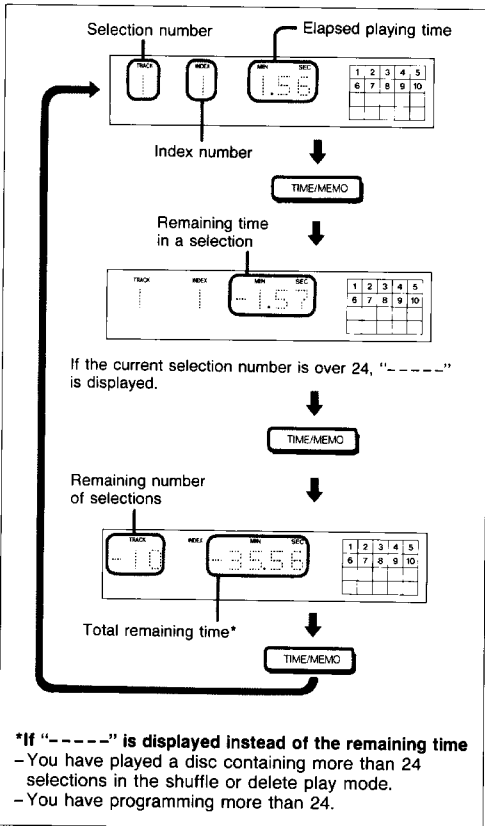

### To change the parts of information display

Each time you press DISPLAY MODE during play, the display changes to give you the following information.

Entire display appears. ←

↓  
Track number, index number and playing time appear.

↓  
Entire display disappears.

### To adjust the brightness of the display

#### - DIMMER function

Press REPEAT while holding down on TIME/MEMO. The brightness adjustment has three tones. The tone you select will be stored in memory so that you do not have to adjust it again after turning the power off.

#### Note

The time display mode selected with the TIME/MEMO button will not change until the power is turned off.

#### If you have stored a disc memo

The stored disc memo will be displayed, following the display of the remaining time of the disc.

# Playing a Disc - Continuous Play

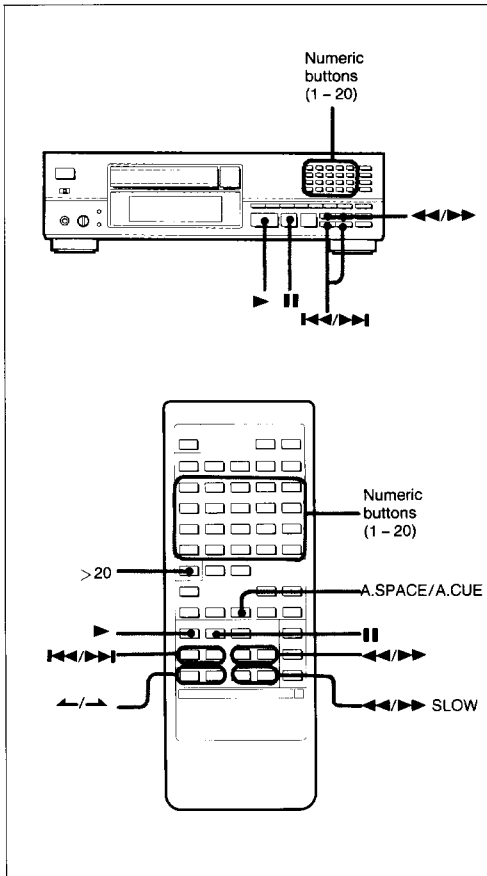

## Locating a Particular Selection

You can locate the beginning of a desired selection during play or pause. There are two ways.

### a) To locate sequentially

#### To locate the beginning of the current or preceding selection

- Press **◀◀** as many times as required.
- Keep **◀◀** pressed to skip selections.

#### To locate the beginning of the succeeding selection

- Press **▶▶** as many times as required.
- Keep **▶▶** pressed to skip selections.

### b) To locate directly

Press one of the numeric buttons ( **1** to **20** ) to enter the desired selection number.

If a selection number is greater than 20, use the **>20** on the remote commander and **1** to **10** buttons. **10** functions as the figure 0.

e.g. To play from selection No. 22, press **>20** **2** **2**

To play from selection No. 30, press **>20** **3** **10**

### When you press **◀◀** during play

The player locates the beginning of the selection.

## Locating a Particular Point in a Selection

There are two ways to locate a particular point you want.

### a) To search quickly while monitoring the sound

Keep **◀◀** or **▶▶** pressed during play and release at the desired point.

### b) To search using an index

You can use this function only with a disc on which index numbers are recorded.

Press **←** or **→** on the remote commander to locate the desired index number.

The selected index number appears in the display window.

### To search quickly by observing the display

Press **||**, then keep **◀◀** or **▶▶** pressed. The search speed will increase, but there will be no sound. Find the desired point by observing the display.

Press **||** or **▶** again at the desired point.

### To search slowly while monitoring the sound

Press **◀◀/▶▶ SLOW** during play and release at the desired point.

### "- OVER -" is displayed

If you continuously press ►► at the end of the disc, "- OVER -" appears in the window. Press ◀◀ or ◀◀ to turn the normal indication.

If you continuously press ◀◀ at the beginning of the disc, play begins automatically from the first selection.

### What is an index?

This is a number assigned to a section of a selection (for example, to a movement in a symphony) to allow that section to be located easily.

## To Play a Selection Immediately from the Beginning – Auto Cue



Auto cue lets you play right from the beginning of a given selection without having to listen to the blank lead-in.

### To use auto cue function

**1** Press A. SPACE/A. CUE twice.



"A.CUE" will appear in the window.

**2** Press II and then make your selection by pressing the numeric button.

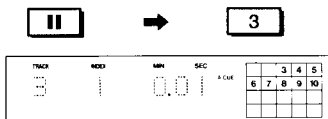

The time display will go out while the player is searching for the beginning of your selection. When the selection has been cued, the time display will come back on. (Some selections may take longer to find.)

**3** Press ► or II.

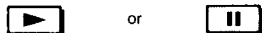

The selection will start immediately.

### To cancel auto cue function

Press the A. SPACE/A. CUE again.

"A. CUE" will disappear in the window.

### Note on auto cue

Selections that fade in slowly or have noise in the lead-in may not be picked up successfully by the auto cue function.

# Playing in a Random Order - shuffle Play

- Shuffle play:** Allows you to play all (up to 99) selections on your disc once each in a random order.
- Delete shuffle play:** Allows you to delete all undesired selections on your disc and play only desired ones.

## Shuffle Play

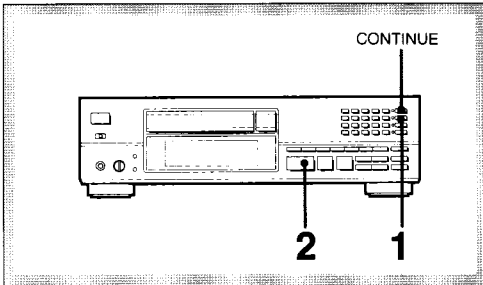

**1** Press SHUFFLE.

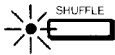

**2** Press ►.

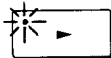

Shuffle play starts.

### To cancel the shuffle play

Press CONTINUE and return to the continuous playing mode.

### To check the remaining time

Press TIME/MEMO (or TIME on the remote commander) once to see the remaining time of the selection being played; twice to see the total remaining time; once more to return to the initial display.

### If you press SHUFFLE during play

Shuffle play begins from the current selection.



### What is this indication?

This indication appears while the player is "shuffling" the selections.

## Delete Shuffle Play

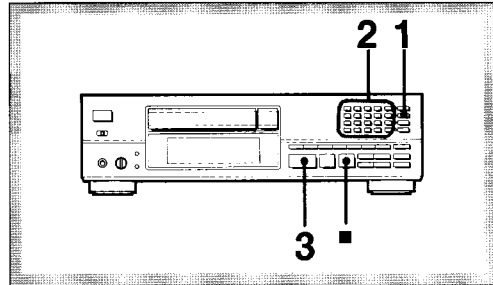

**1** Press SHUFFLE.

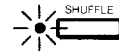

**2** Press the numeric button(s) of undesired selection number to be deleted.

The number disappears.

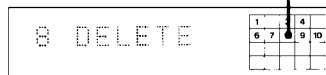

To put back a selection which you have deleted, press the numeric button for that selection. "SELECT" will be displayed in the window.

**3** Press ►.

Delete shuffle play starts.

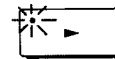

### To put back all selections which you have deleted

Press ■ during stop.

### To delete a selection during play

Press the numeric button for that selection. "DELETE" will appear in the display. You can also delete a selection being played by pressing the CLEAR button.

### Delete bank function

You can keep the desired selections in memory for each disc by using the delete bank function. (page 37)

# Playing Only the Desired Selections – Delete Play

Delete play allows you to delete all undesired selections on your disc and play only desired ones. The player will skip the undesired selections and play the desired ones in the ascending order of their selection number. In the delete play mode, therefore, you can play only the desired selections continuously.

## To Delete the Undesired Selection Before Playing

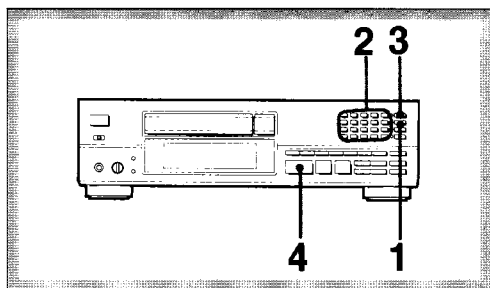

**1** Press **SHUFFLE**.



**2** Press the numeric button(s) of undesired selection number (to be deleted).

The number disappears.

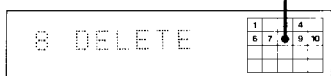

To put back a selection which you have deleted, press the numeric button for that selection. "SELECT" will be displayed in the window.

**3** Press **CONTINUE**.

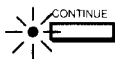

**4** Press **▶**.

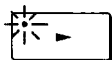

Delete play starts.

## To Delete a Selection During Play

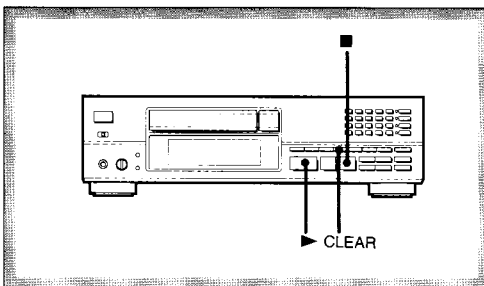

When playing the beginning of an undesired selection, press **CLEAR** in the continuous playing.



The number disappears.

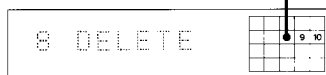

The player skips the undesired selection to play the next one.

### When play ends

Selections except deleted ones will be restored.

### To play again

Press **▶**. Delete play starts.

**To put back a selection which you have deleted,** press the numeric button for that selection. "SELECT" will be displayed in the window.

**To put back all selections which you have deleted,** press **■** during stop.

If you press **SHUFFLE** during delete play, your selections will be played in the delete shuffle play mode.

### For a disc with selections more than 24

The remaining time of the disc as a whole appear as "-----".

### Delete bank function.

You can keep the desired selections in memory for each disc by using the delete bank function. (page 37).

# Playing the Beginning of Each Selection

## - Music Scan Play



**Music scan:** Allows you to play the beginning of each selection in any play mode. As such, it is useful for checking the contents of your disc or program. In the music scan mode, you can set playing time to 10, 20, or 30 seconds.

**Music scan delete play:** Allows you to play the beginning of undesired selections to delete them and play only desired ones.

When you delete the undesired selections, the unit plays just the selections you prefer in shuffle play mode.

### Music Scan Play

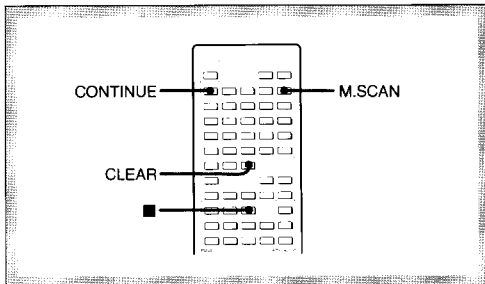

Press M.SCAN during stop.



Each time you press M.SCAN the display will be as follows:

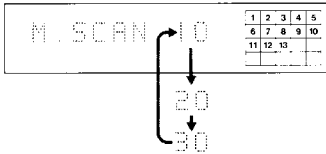

The indicator on the ► button flashes and beginning of each selection is played for 10, 20 or 30 seconds as designated.

**If you press MUSIC SCAN during play of the beginning of a particular selection:**

You can extend the current playing time by specified seconds.

**To start play immediately**

Press ►. The indicator on the ► button lights up, normal playback will start from the selection being played. If you press ◀◀/▶▶, music scan play will be overridden by continuous play.

**To stop the music scan play during scanning**

Press ■.

### Music Scan Delete Play

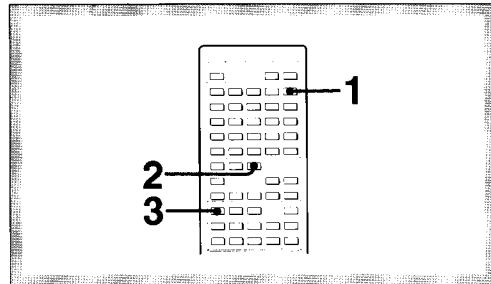

**1 Press M.SCAN in the stop mode.**



The indicator on the ► button flashes.

**2 When playing the beginning of an undesired selection, press CLEAR.**



The next selection will be played. When the all selections have been played, player stops.

**3 Press ► button to play the remaining selections after all the selections have been scanned.**



**When music scan delete play ends**

Selections except deleted ones will be restored.

**To put back a selection which you have deleted**

Press the numeric button for that selection. "SELECT" will be displayed in the window.

**To put back all selections which you have deleted,**

Press ■ during stop.



# Playing Repeatedly – Repeat Play

**Repeat play:** Allows you to repeatedly play all selections or one particular selection on your disc in any play mode.

**A – B repeat play:** Allows you to repeatedly play a particular portion (starting with point A and ending with point B) on your disc. Useful for learning foreign languages or lyric lines.

## Repeating Selections

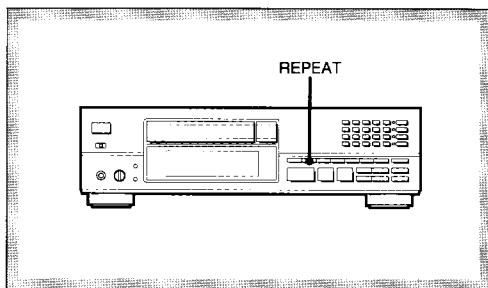

Press REPEAT before or during play.

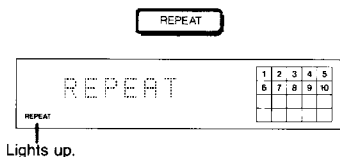

Lights up.

The player repeats the current playing mode.

Playing mode	Selections to be repeated
Continuous play	All the selections or a single selection
Delete play	Repeat playing selections except deleted ones
Shuffle play Delete shuffle play	Selections that the player reshuffles
Program play	All the selections programmed in the same order
Custom index play	Between the specific custom indexes

### To repeat a single selection

Press REPEAT again during repeat play of the continuous or delete playing mode. "REPEAT 1" appears.

### To cancel repeat play

Press REPEAT again. "REPEAT" disappears. To cancel repeat play of the continuous play, press "REPEAT" twice. "REPEAT" disappears.

#### Note

Repeat play cannot be conducted on multi-disc programs.

## Repeating a Particular Portion – A – B Repeat

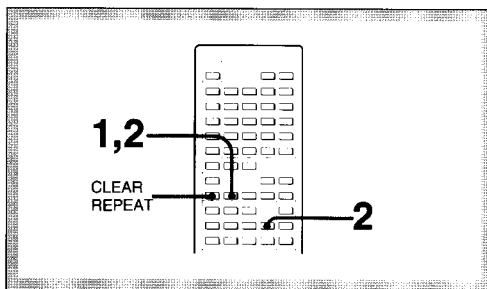

**1** Press A ↔ B at the starting point (point A) of the portion to be repeatedly played.



"A SET" is displayed and "A-" flashes.

**2** Either continue playing the portion or press ► to reach the ending point (point B) of the portion and then press A ↔ B again.



"REPEAT A – B" appears.

The player memorizes the ending point (point B) and repeat play the specified portion starts.

### To set a new starting point

Press A ↔ B repeat during play in the A – B repeat mode. The ending point (B) becomes the new starting point (A) and play is continued. To designate the new ending point (B), press A ↔ B repeat again at your desired place. The new A – B repeat portion is set. You can advance the portion by repeating the above operation.

### To cancel A – B repeat

Press REPEAT.

### Going back to the same point (A) from any point on the disc

Press A ↔ B to designate the desired point (A). (Point B need not be designated.)

You can go back to point A from any point on the disc by simply pressing ►.

#### Note

You cannot designate point A and B in two different selections.

# Playing in a Desired Order – Program Play

Program play allows you to play up to 24 programmed selections in the order in which they are programmed. This section shows the basic method of programming selections. For the method of programming selections to be recorded on your tape, see page 22.

## Programming and Playing

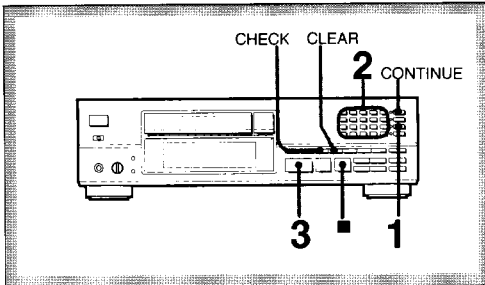

### 1 Press PROGRAM.

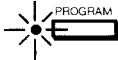

### 2 Press selection number in the desired order.\*

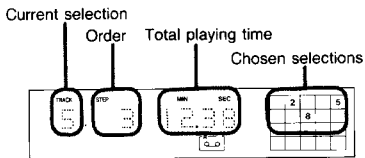

**If you choose wrong selections, press CLEAR.** Each time you press CLEAR, the last chosen selection will be deleted.

\*To choose a selection over 20, see page 12.

### 3 Press ►.

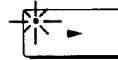

Program play starts.

#### To stop playing

Press ■.

You can play the same program repeatedly as long as you do not cancel program play or erase the program.

#### To cancel program play

Press CONTINUE and return to the continuous playing mode.

The program will be erased.

#### To check your program

Press CHECK and the first selection in the program will be displayed.

Each time you press CHECK, the next selection in the program will be displayed. When CHECK is pressed after the last selection, “- END -” appears and then the display returns to the initial display.

## To Change Your Program

#### To erase the last selection, press CLEAR.

Each time you press CLEAR, the last selection in the program will be erased.

**To add a selection to the end of the program, just press the numeric button for that selection.** You can also add selections during play or stop.

**To delete a selection, press CHECK repeatedly until the undesired selection is displayed.** Then press CLEAR.

**To change the order, press ■ during stop to erase the program.** Then repeat the programming procedure from the beginning.

**When you use the auto space function**

All the blank spaces between selections, whether short or long, will automatically be set uniformly to 3 seconds. Therefore, playing time displayed for each selection will include additional 3 seconds. (page 29)

**When the power is turned off while playing a program selection**

The program is erased.

**When pressing PROGRAM during playing**

The current playing selection will be the first one. You can program while playing.

**If "----" is displayed instead of the actual time**

- You have programmed a selection number over 24.
- The total time is exceeded 100 minutes.

**To check the remaining time in the program play**

Press TIME/MEMO once to see the remaining time of the selection being played; twice to see the total remaining time; once more to return to the initial display.

If you have inserted a pause, the display shows the total remaining time until the pause.

**Program bank function**

You can have the player memorize programmed selections for each disc. (page 36)

# Fading in And Fading out Play – Fade-in/Fade-out

Fade-in and fade-out allow you to record selections on your tape in such a manner that their play may not start and stop suddenly. You can have the play fade out between 2-10 seconds. When no time is specified, the play will fade in and fade out for 5 seconds. This function cannot be operated when the DIGITAL OUT (OPTICAL) is used for connections.

## Fading in/Fading out

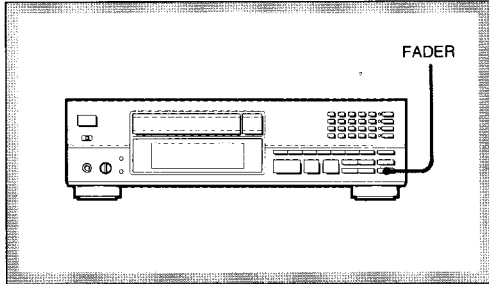

### To end the play fading out

Press FADER when you want to start fading out.

⏸️ flashes in the window, and play fades out and enters the pause mode.

### To restart the play fading in

Press FADER in the pause mode.

⏪️ flashes in the window, and play fades in.

### Using custom file function

The last designated fade time also remains for the discs with custom files.

## To Set the Fade Time

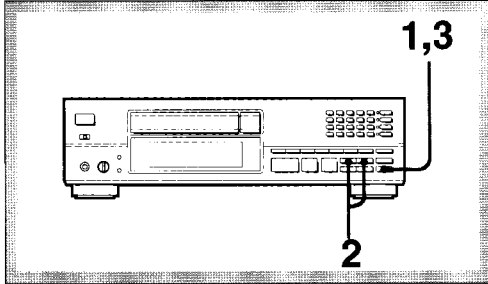

### 1 Press FADER during stop.



Fade time

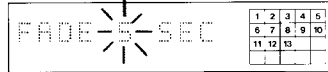

### 2 Press ⏪️/⏩️ to select fade time between 2-10 seconds.



### 3 Press FADER.



# Custom Edit

Custom edit is a useful function for editing selections on a disc on your tape. The following types of custom edit are available with the player.

## Editing Desired Selections in a Desired Order

### Program play

Program play is a basic type of custom edit that allows you to edit up to 24 selections as you want. It also allows you to edit selections on side A separately from those on side B and check the total playing time during editing.

- **Pause program**  
Allows you to program a pause and edit selections on side A separately from those on side B (see page 22).
- **Program edit**  
Allows you to check the total playing time during editing by pressing **◀◀▶▶** AMS and PROGRAM (page 22).

### Multi-disc program

Multi-disc program allows you to edit up to 24 desired selections on up to six discs in the program mode. If you choose desired selections on the first disc and then open the disc tray, the player will enter the multi-disc program mode (page 24).

## Editing Selections Automatically According to the Length of Your Tape

### Editing navigation

After each step, you can see the proper operation guide of what you should do next.

### Time edit

Time edit automatically edits selections on sides A and B according to the length of one side of your tape, thus improving an editing efficiency. It also edits programmed selections in preference to the others.

It automatically edits selections without changing their original order on your disc (page 26).

### Just edit

Just edit is an improvement of time edit. Like time edit, it edits programmed selections in preference to the others. Unlike time edit, however, it automatically edits selections according to the length of one side of your tape by changing their original order on your disc (page 26).

### Link edit

When either one side of your tape is not fully occupied by selections edited by time edit or just edit, "LINK" will flash together with the selection numbers in the music calendar for those selections fitting the remaining tape length. Link edit links the fitting selections to edited ones whether the former is on the current disc or a new disc (page 27).

## Fade-out at Desired Time – Time Fade

Time fade automatically causes selections to fade out at specified time. This function is useful for replacing multiple discs or editing multiple 8-cm (3-inch) CDs because the player will retain the remaining playing time when it is stopped or the disc tray is opened during play.

Time fade is available in the continuous play, program play, shuffle play, and repeat play modes. It operates twice for both sides (see page 28).

## Inserting a Blank Space Between Selections – Auto Space

Auto space automatically creates a 3-second blank space between selections during play to arrange them at an equal interval (page 29).

## Locating Highest-level Portion of Disc – Peak Search

When editing selections on your tape, you need to adjust a recording level. An excessively high recording level results in distorted sound while an excessively low recording level causes great noise.

Peak search repeatedly plays the highest-level portion of selections on your disc or programmed selections for four seconds. As such, peak search allows you to optimize a recording level (page 29).

# Recording Programed Selections on a Tape

You can program up to 24 selections in a desired order according to the length of your tape on which they are to be recorded. You can also program selections to be recorded on side A simultaneously with those to be recorded on side B on your tape.

## Programming and Playing

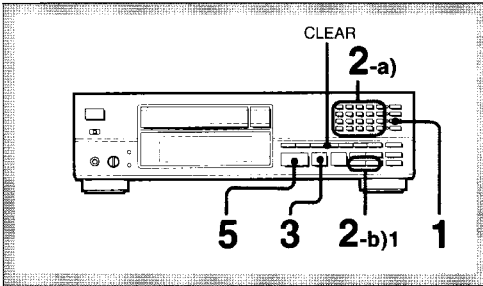

### 1 Press PROGRAM.



### 2 a) Press selection number in the desired order.\*

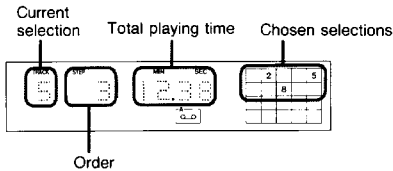

If you choose wrong selections, press CLEAR. Each time you press CLEAR, the last chosen selection will be deleted.

\*To choose a selection number over 20, see page 12.

### b) To program selections while checking the total playing time (Program Edit):

1 Press **AMS** instead of the numeric buttons to choose selections to be programmed.

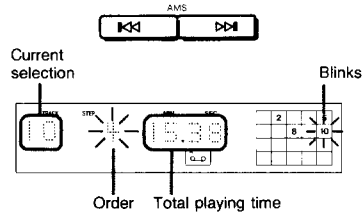

Press **AMS** repeatedly to choose an appropriate selection.

2 After choosing the selections to be programmed, press PROGRAM.



### 3 If you program selections on side B, press **II** to program a pause.

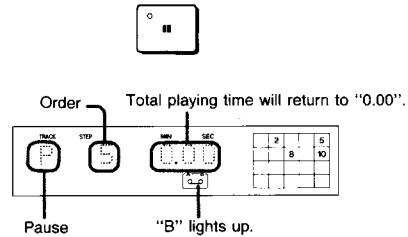

The pause is programmed as the fifth selection. Note that the player counts pauses as selections to be programmed.

**4** Program the selections for side B.  
Repeat step 2.

**5** Press ►:

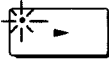

The selections for side A starts playing.

#### To play the selections for side B

When the selections for side A are played, the player will pause. Set the tape to the beginning of side B ("B" lights up.), then press ► or II.

When the program being played is on side A, [A] appears. When it is on side B, [B] appears.

#### To stop playing

Press ■.

You can play the same program repeatedly as long as you do not cancel program play or erase the program.

#### To cancel program play

Press CONTINUE and return to the continuous playing mode.

The program will be erased.

#### To erase the entire program

Press ■ once during stop; twice during play.

The program is also erased when you turn off the player.

#### To check your program

Press CHECK. The first selection in the program will be displayed.

Each time you press CHECK, the next selection in the program will be displayed. When CHECK is pressed after the last selection, "- END -" appears for 1 second and then the display returns to the initial display.

When the program being checked in on side A, [A] appears. When it is on side B, [B] appears.

## To Change Your Program

For operation, see page 18.

#### When you use the auto space function

All the blank spaces between selections, whether short or long, will automatically be set uniformly to 3 seconds. Therefore, playing time displayed for each selection will include additional 3 seconds. (page 29)

#### If "-----" is displayed instead of the actual time

- You have programmed a selection number over 24.
- The total time is exceeded 100 minutes.

#### To check the remaining time

Press TIME/MEMO once to see the remaining time of the selection being played; twice to see the total remaining time; once more to return to the initial display.

If you have inserted a pause, the display shows the total remaining time until the pause.

#### Your program is erased when:

- You change the continuous play mode.
- You turn off the power during program play.

# Designating the Playing Order of Up To 6 Discs

## - Multi-disc Program

Multi-disc program allows you to program selections on one disc after another. You can choose up to 24 selections from up to six discs for playing in any desired order.

### Programming

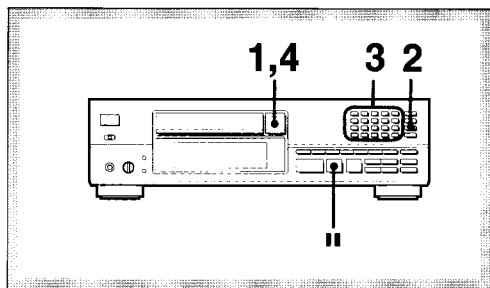

**1** Insert the first disc in the player.

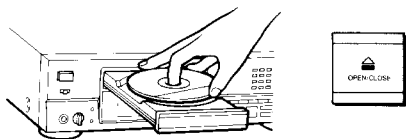

**2** Press PROGRAM.



**3** Program desired selections on the first disc.  
Press the appropriate numeric buttons or press **◀◀▶▶** and PROGRAM.  
For details, see page 22.

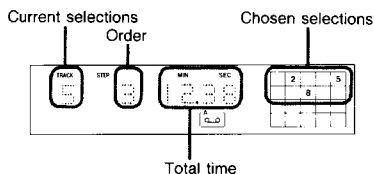

**4** Replace the first disc with the second one.

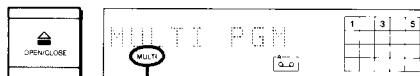

Lights up.

Remove the disc, "MULTI PGM" is displayed and "MULTI" lights up in the window. Insert the second disc, "DISC-2\*" is displayed.

**5** Repeat steps 3 and 4 to program additional selections.

Up to 24 selections from up to 6 discs can be programmed. The total playing time from the first disc is displayed for the time display.

**To proceed to program selections to be recorded on side B**

Press **II** to put a pause and then program selections to be recorded on side B.

If you press **▶** by mistake when inserting the second disc: The multi-disc program will be overridden by the continuous play mode. Note that the programmed selections on the first disc will be cancelled at this time.

**To check the current disc number**

Press TIME/MEMO (or TIME on the remote commander) during stop. The disc number will be displayed.

**To program selections on the same disc**

You can program selections on the same disc again.

The following functions cannot be conducted on Multi-disc programs.

- Repeat play
- Program bank

**If you set the auto space function**

The auto space cannot be set during multi-disc programming. Be sure to set the auto space before programming.



## Playing the Program

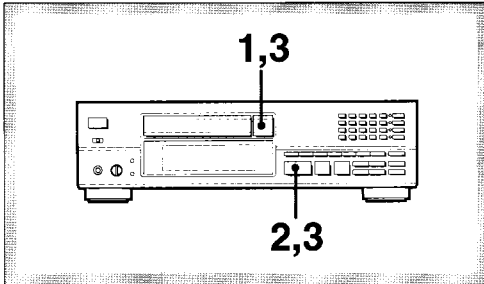

- 1** Insert the first disc in the player.

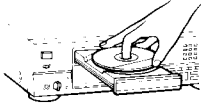

- 2** Press ►.

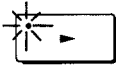

After completion of play of the selections on the first disc, the message below will appear on the display window.

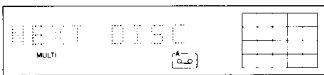

- 3** Replace with the next disc and press ►.  
Continue replacing until the last disc.

After the last disc has been played, "-END-" appears in the window and the player returns to the initial standby condition.

### To play the selections for side B

When the selections for side A are played, the player will pause. Set the tape to the beginning of side B ("B" lights up.), then press ► or ■.

### To stop playing

Press ■.

### To cancel multi-disc program

Press CONTINUE and return to the continuous playing mode. The program will be erased.

### To check your program

Press CHECK. Each time you press CHECK, the selection in the program will be displayed along with its selection, order and disc number.

When CHECK is pressed after the last selection "-END-" appears and then the display returns to the initial display.

## To Change Your Program

You can make the following changes before starting play.

### To erase the last selection

Insert the last disc programmed and press CLEAR. Each time you press CLEAR, the last selection in the program will be erased. To continue erasing selections, replace the disc accordingly and repeat the procedure.

If a pause has been programmed, the selections programmed before the pause cannot be cleared.

### To add a selection to the end of the program

Insert a disc and press the numeric button for that selection.

You can add a selection during stop.

### To erase the entire program

Press ■ once during stop; twice during play. The program will be erased.

### If you make a mistake in the disc order

Even if a disc is inserted in an incorrect order, the selections chosen from that disc will be played. However, when a disc which has already been played is inserted, program play will not proceed. In addition, when a seventh disc is incorrectly inserted, "DISC FULL" will be displayed.

### To check the remaining time in multi-disc program play

Press TIME/MEMO (or TIME on the remote commander) once to see the remaining time of the selection being played; twice to see the remaining time of the disc being played. The remaining time of the program cannot be displayed for multi-disc programs.

# Designating the Total Playing Time

## - Time Edit/Just Edit



If you specify the total length of your tape, the player will accordingly program selections to be recorded on sides A and B of your tape.

**Time edit:** Edits selections on your tape without changing their original order on your disc, choosing the last few selections that fit the remaining length of your tape.

**Just edit:** Edits selections on your tape by changing their original order on your disc, choosing those selections which fit the specified total length of your tape.

If you use the auto space function, you can automatically insert a 3-second blank space between selections. Therefore, playing time of each selection includes additional 3 seconds.

### Programming

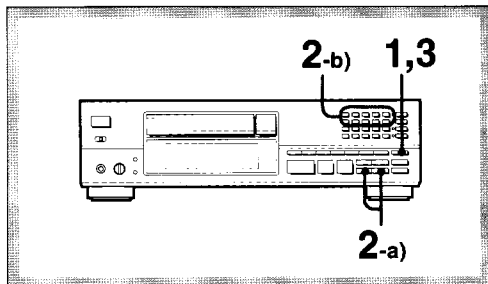

If you want to edit particular selections on your tape in preference to the others, program those selections beforehand (page 18).

If selections are programmed beforehand, the HALF DISC mode will not work with Time Edit.

### 1 Choose either time edit or just edit during stop, press EDIT/TIME FADE.

EDIT/TIME FADE

- Time edit — Press once, "TIME EDIT" is displayed.
- Just edit — Press twice "JUST EDIT" is displayed.

### 2 Specify a desired recording time.

#### a) When you specify a commercially available tape length:

Each time you press **▶▶**, the display changes to give you the following duration:

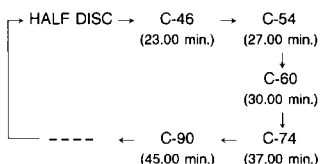

By pressing **◀◀**, you can reverse the above cycle.

HALF DISC cannot be set on the disc with selections more than 24.

Example: a 54 minute tape



↓ After 1 second

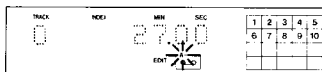

#### About the HALF DISC edit

**Time edit** — Editing starts at the first selections on the disc. At about half point, selections are distributed to side A and B.

**Just edit** — Changing the order to fit the playing time to a half of playing time as close as possible, selections are distributed to side A and B. Note however, that more selections may be allocated to side A than side B.

#### b) When you specify a free tape length:

Use numeric buttons ( **[1]** - **[10]** ).

Press **[10]** for "0".

You need not press keys for seconds, unless required.

Example: a 46 minute tape (23 minutes per side)

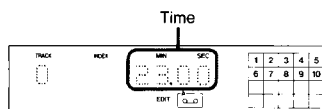

**3 After specifying the desired recording time, press EDIT/TIME FADE once.**



The program for side A is completed. If "LINK" flashes, see "Adding Selection(s)".

- **When you choose time edit**  
The player will program selections on your disc in the ascending order of their selection number, choosing the last selections that fit the remaining length of your tape. "EDIT" and "A-" lights up. "B" flashes.
- **When you choose just edit**  
The player will program selections on your disc in a random order, choosing those selections which fit the specified total length of your tape. "EDIT" and "A-" lights up. "B" flashes.

**4 Press EDIT/TIME FADE once more, to make a program for the other side of your tape.**  
If "LINK" blinks, see "Adding Selection(s)".

**Editing Navigation**

After each step, you can see the proper operation guide of what you should do next.

Message	Operation
PRESS [AMS] or [1 ~ 10]	Press the ◀▶▶▶ AMS button or one of the numeric buttons ( [1] ~ [10] ).
PRESS [EDIT] for SIDE-A(B)	Press the EDIT/TIME FADE button to edit Side-A (or Side-B).
ADD TRACK by [1 ~ 20] or CHANGE DISC	Either add a track(s) (=selections) by using the numeric buttons ( [1] ~ [20] ) or change the disc.
SPACE LEFT 1'22 PRESS [EDIT] to FINISH	1'22" remains but no selection from the disc can be accommodated. Press the EDIT/TIME FADE button to end.

**Adding Selection(s) — Link Edit —**

After all selections on the disc have been programmed, if there is a selection(s) shorter than the remaining time, "LINK" and the selection numbers will flashes.

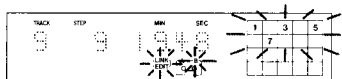

To add selection, press the numeric button for the selection number or press EDIT/TIME FADE again. When pressing EDIT/TIME FADE, a program will be made automatically to fit the playing time as close as possible to the remaining time.

If the remaining time can contain other selection(s), "LINK" and the selection number keep flashing. When "LINK" flashes, if the disc is replaced by another disc, the new selection number(s) on the new disc that fit in the remaining time will flash. "EDIT" disappears when the rest of the playing time is less than 1 minute. Whether "LINK" is flashing or not, you can replace the disc by another disc and choose selection(s) to fit the remaining time.

To clear "EDIT" from the window, press ■.

**Playing the Program**

Press ▶. The selections for side A will be played and then the player will pause. "B" lights up in the tape side indicator. Set the tape to the beginning of side B, then press ▶ or ■.

**To stop playing**

Press ■. You can play the same program repeatedly as long as you do not cancel time edit or erase the program.

**To cancel time edit/just edit**

Press CONTINUE and return to the continuous playing mode. The program will be erased.

**To erase the entire program**

Press ■ once during stop; twice during play. The program is also erased, when you turn off the player.

**If your disc has more than 24 selections**

Selections over 24 cannot be programmed automatically program desired selections before using the time edit function. See page 18 for details.

**You cannot edit selections in the following cases**

- If you have programmed up to 24 steps (i.e. selections plus pauses).
- If you have programmed selections whose playing time exceeds one hour.

**Note**

Playback can be performed when "EDIT" is displayed.

**After programmed selections are played**

Time edit or just edit will be cancelled.

**When JUST EDIT programming takes too long**

The JUST EDIT programming feature may take a long time if the disc has a lot of selections on it. In this case, you can stop the programming by pressing ■. Selections that best fit the playing time at that point will be programmed.

**To designate a different time for each side**

Execute steps 1 to 3 and press ■. Then repeat steps 1 through 3. Do not execute step 4.

# Fading Out at the Desired Time — Time Fade



You can have the play fade out at the end by designating the play duration. Once time fade is set, it functions twice for editing both sides of the tape. You can change discs without canceling this function.

This function cannot be conducted on multi-disc program or when the DIGITAL OUT (OPTICAL) is being used for connections.

## Setting the Time Fade and Playing

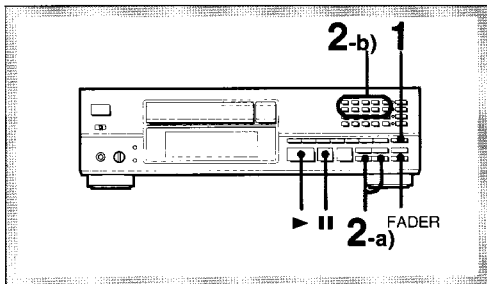

- 1 Press EDIT/TIME FADE three times during stop or once in the pause mode.

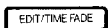

TIME FADE and are displayed in the window.

- 2 Specify desired fade time.

- a) When you specify a commercially available tape length:

Each time you press ►►, the display changes to give you the following duration.

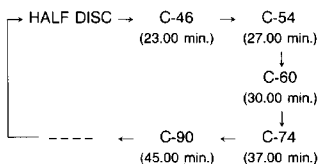

By pressing ◀◀, you can reverse the above cycle.

With HALF DISC, the playing time is set to half of the total playing time.

Example: a 54 minute tape



↓ After 1 second

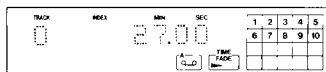

- b) When you specify a free tape length:

Use numeric buttons ( [1] - [10] ).

Press [10] for "0".

You need not press keys for seconds, unless required.

Example: a 46 minute tape (23 minutes per side)



Time

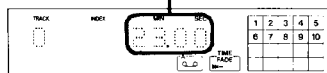

- 3 To start play, press ►.

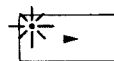

After the designated time, play fades out and pauses. Tape side B lights up.

Press ► or || to resume playing for other side of the tape.

If you press FADER, fade in will start. When the play fades out for the second time, the player pauses and the time fade function is canceled.

### When playback of a disc ended before the designated playing time

The time fade function will remain effective even for a new disc(s) added for the remaining playing time originally designated, and the fade out starts in accordance with the initially set fade time.

### To cancel time fade

Time fade will be canceled when

- EDIT/TIME FADE is pressed once again.
- ◀◀/►► is pressed during play.

### To display the time remaining until the time set

Press TIME/MEMO (or TIME on the remote commander) twice.

## Locating the Loudest Portion of the Disc - Peak Search



The player will search the loudest portion (peak level) of the disc, and then play it repeatedly. This function will make it easier for you to adjust to the optimum level when recording on tape.

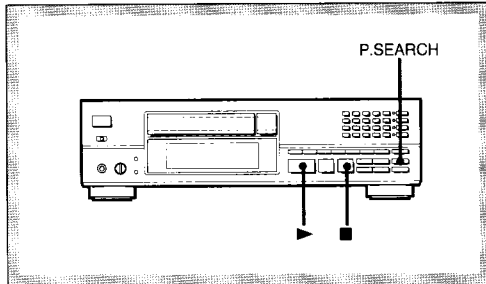

Press **P.SEARCH** in the stop mode.



"PEAK" flashes in the window. The loudest portion will be playing repeatedly for 4 seconds. At this time, adjust the recording level.

### Notes

- In the delete play, delete shuffle play, or program play mode, when a single disc is inserted in the player, selections chosen from that disc will be searched for a peak.
- In the multi-disc program mode, when multiple discs are inserted, peak search will apply to selections chosen from the currently inserted disc.

### To stop peak search

Press **■**. Press **||** to pause at the first selection. "PEAK" will disappear in the display window.

### To start play immediately

Press **▶**.

### Note on peak search function

The player determines the loudest portion (peak level) of a disc by searching it at fixed intervals. As a result, the portion searched may differ from the actual peak level. In addition, this function may determine different portions as the peak level for the same disc. However, the difference between the portion searched and the actual peak level is insignificant and will not present any problem in adjusting the recording level.

## Inserting a Blank Space Between Selections - Auto Space

You can insert a 3-second blank space between each selection. The blank space enables you to locate selections when using a tape deck with the automatic selection search function.

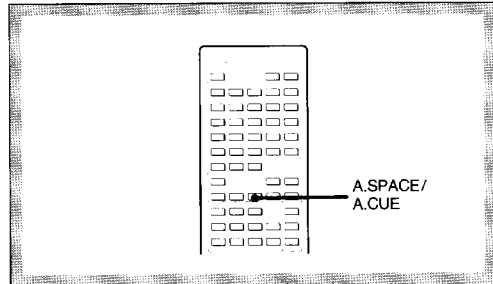

Before starting play, press **A.SPACE/A.CUE** once.



"AUTO SPACE" appears in the window. A blank space of approximately 3 seconds will be inserted between each selection.

### To cancel the auto space function

Press **A.SPACE/A.CUE** twice. "AUTO SPACE" disappears.

### Note on auto space function

When selections consist of several chapters following one after another successively like symphonies, the auto space function may create breaks between each selection.

# Custom Files

The CD player incorporates a memory in which you can store five types of informations called "custom files".

## Five Custom Files

Level file	You can assign a playback level to each individual disc, so that the disc can be played automatically on a fixed playback level. (page 31)
Disc memo	You can assign a title within 10 letters to each individual disc. (page 32)
Custom Index	You can assign up to 10 index points on anywhere you want on a disc. (page 34)
Program bank	A programed playing order you store in memory for a disc, so that the disc can be played always in the fixed order. (page 36)
Delete bank	You can store certain selections in memory so that the player will always play only desired selections. (page 37)

### What is this indication?

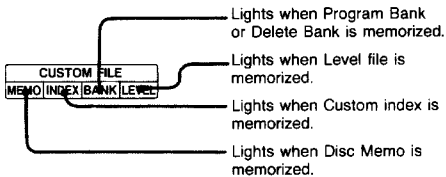

### Custom File Last Mode Memory

The last play mode (continuous play mode, and fade time) of a disc containing custom file will be retained in the player's memory when the disc is removed from the player. When the disc is inserted again, the last play mode will be recalled. However, if you press ► while the disc tray is open, the current play mode will take priority over the last play mode memorized.

### Where are custom files memorized?

Custom files are memorized not in the disc but in the player's memory. So you can't enjoy custom files with the other players without memorizing custom files again. Custom files are retained for approximately 1 month without AC power supply.

### To check the items of the custom files

Press FILE RECALL without the disc inserted (while "NO DISC" is displayed). Each time you press FILE RECALL, the items of the custom files and items of the each column of  about the disc are displayed. If you press FILE RECALL when the last disc's information is displayed, "END" is displayed and returns to "NO DISC" after a few seconds.

### To clear all custom files of a disc at once

Each time you press FILE RECALL, the contents of disc memos and the items of custom files are displayed in the window. When the disc memo is assigned in a disc, you can see these displays even if a disc is not inserted in the player.

When the display which you want to clear appears, press ERASE. All the custom files of a disc are cleared and "FILE ERASE" will appear in the window.

### How many discs can be assigned to custom files?

You can give custom files to up to 185 discs.

But it takes two discs' memory in the following cases:

- When disc memo, custom index, program bank and delete bank are memorized for one disc at the same time.
- When more than 9 custom indexes and disc memo are memorized for one disc at the same time.
- When custom index, program bank and delete bank are memorized for one disc at the same time.

### When the memory becomes full of custom files.

"FILE FULL" indication appears when FILE is pressed while no custom file can be memorized for the disc currently put in the player. To make a custom file for the disc, clear the custom file of another disc.

### To clear custom files or to reset memory of all discs at once

When the disc tray is empty, press POWER to turn on the player while keeping ERASE and FILE pressed. "ALL ERASE" is displayed in the window.

### Note on program bank

A single disc cannot be assigned with both a program bank and a delete bank. Multi-disc programs cannot be stored in memory.

# Storing an Optimum Playback Level for Each Disc – Level File

You can have the player memorize an optimum playback level for each individual disc. Each time you play a disc, the volume will be set to the level memorized for that disc. This function can be used when the amplifier is connected to the VARIABLE LINE OUT terminals or when headphones are used.

## Memorizing an Optimum Playback Level

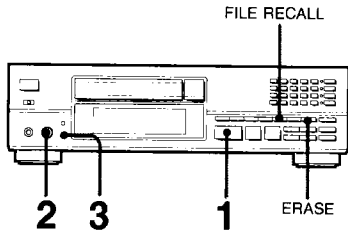

**1** Press **▶** to start play.

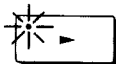

**2** Adjust to the desired playback level.



**3** Press **LEVEL FILE** to have the playback level memorized.

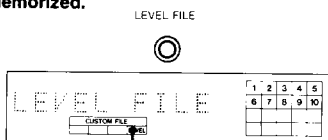

Lights up.

## Clearing the Level File

**1** Insert the disc whose level file is to be cleared in the tray.

**2** Press **LEVEL FILE**.

**3** Press **ERASE**.

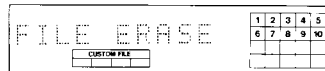

When "FILE ERASE" is displayed and "LEVEL" disappears, the level file is cleared.

### Note

This function cannot be operated when the DIGITAL (optical) OUT is used for connections.

### To play the disc using the level file

Each time a disc is inserted into the player, the LINE OUT/PHONE LEVEL will be automatically turn to the designated playback level.

### When the playback level is changed

Press FILE RECALL during stop. The LINE OUT/PHONE LEVEL will be automatically reset to the memorized playback level.

# Assigning Names to a Disc - Disc Memo

Using the disc memo function, you can assign a name within 10 letters for each disc. The memo appears in the window every time you put the disc in the player. One name can be assigned for one disc. For the disc memo function, 78 letters (including a space, characters, and symbols) are available. You can use these letters to assign a title, musician name, genre, date of purchase, and other disc memos to your disc. "NO DISC-" can be changed to a desired indication.

## Assigning a Disc Memo to Your Disc

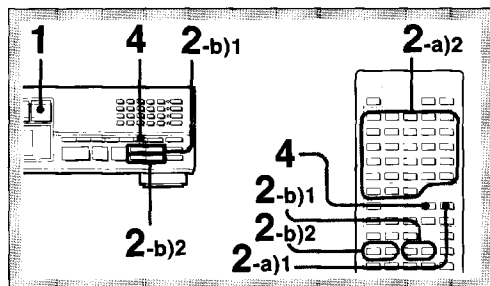

- 1** Insert the disc to which you want to assign a disc memo.

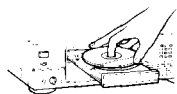

Make sure that the total number of selections and the total playing time is displayed.

- 2** Input a desired disc memo.  
The letters available as a disc memo are shown on the right page. You can input a disc memo more quickly by using the remote commander. You can also input a disc memo during play.

- a) When you input alphanumeric characters as a disc memo**

- 1** Choose the desired capital letters, small letters, or numbers.

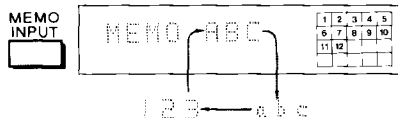

Each time you press MEMO INPUT, the display changes as shown above.

- 2** Press the applicable letter button.

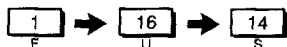

Move the cursor to select the next letter.

To change to small letters or numbers, return to the step 1.

**b) When you input non-alphanumeric characters as a disc memo**  
To input them during play, press MEMO INPUT on the remote commander. Use the ◀◀/▶▶ DISC MEMO buttons

**1** Press ◀◀ or ▶▶ until the desired symbol or letter appears.

**2** When the desired letter appears, press ▶▶.

Move the cursor to select the next symbol/letter. Lights up.

**3** Repeat step 2 to input the disc memo. You can write up to 10 letters.

**4** Press FILE.

Lights up.  
After about 1 second.

Each time the disc is put in the player, the memo will be displayed.



## Clearing the Disc Memo

**1 Insert the disc whose memo you want to clear in the tray.**

**2 Press MEMO INPUT or ◀▶.**  
The first letter in the disc memo flashes.

**3 Press ERASE.**



When "FILE ERASE" is displayed and "MEMO" disappears, the disc memo is cleared.

### To rewrite letters or symbols before pressing FILE

Move the cursor under the letter/symbol to be changed, and then select the desired letter/symbol using ◀▶. Press DISC MEMO. To erase the letter and make space, locate the desired place with ◀▶ and press CLEAR.

### Usable letters and symbols

For the disc memo, 78 letters and symbols and space can be used. When the ◀▶ button is pressed for the first time, the space appears. Each time ▶ is pressed, letters and symbols will appear in the following order.

```
(Space) A B C D E F G H I J K L M N O P Q R  
S T U V W X Y Z & a b c d e f g h i j k l m n o  
p q r s t u v w x y z ' ~ = [ ] < > ! ? * / +  
: . 9 8 7 6 5 4 3 2 1 0 -
```

Use ◀ to call up a previous character.

### Note

- Symbols cannot be entered with the letter buttons. To enter symbols, use the ◀▶ DISC MEMO buttons.
- The only characters that can be entered directly for your disc memo have the orange letter on the remote commander.

# Indexing a Disc – Custom Index

A custom index is a special index that can be assigned to any position you want on the disc. If you assign custom indexes to the positions on a disc, you can easily locate the positions during play, or enjoy repeat play between two adjacent custom indexes.

## Assigning Indexes to Your Disc

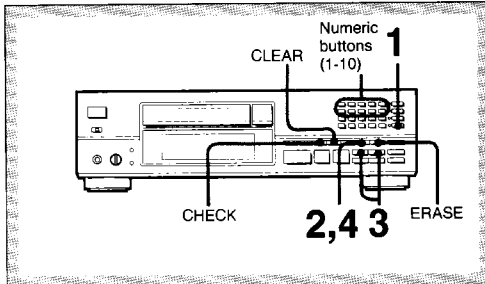

### 1 Press C.INDEX during play.

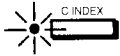

The music calendar disappears.



### 2 Press FILE where you want to assign a custom index.



The index number flashes

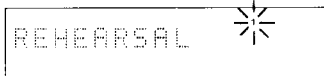

The 3-second portion from the point where you pressed FILE is played repeatedly (rehearsal play).

### 3 Adjust the repeat start point using ◀◀ or ▶▶.



Press ▶▶ to shift the repeat start point forward and ◀◀ to shift it backward. Pressing ◀◀/▶▶ 7 times shifts the point by approximately 1 second.

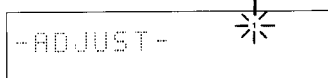

### 4 Press FILE to store the custom index. The custom index is assigned to the repeat start point.

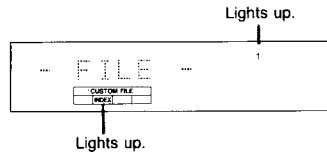

### 5 You can assign custom indexes up to 10 positions by repeating steps from 2 to 4.

#### To release rehearsal play

Press CLEAR, to resume normal play.

#### If a new custom index is assigned to a position preceding another index

Previously existing indexes will be shifted as follows. Example: If you assign a new index between 2 and 3.

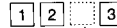

A new index

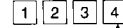

The old index 3 becomes 4

#### During custom index play

You cannot use the normal index search, however, search of custom index function is possible.

#### If you press FILE in the pause mode

The rehearsal play is not made and the custom index is assigned immediately at the position where FILE is pressed.

If you press the M.SCAN in the C.INDEX mode, the beginning of each custom index is played.

## Playing from the Desired Custom Index

There are three ways to play from a desired custom index.

### a) To play from an index to the end of the disc

- 1 Press C.INDEX.
- 2 Select the desired custom index by pressing the corresponding numeric button 1 through 10.





### b) To play from one index to the next

- 1 Press C.INDEX twice so that "C.INDEX 1" and "SINGLE" are displayed.
- 2 Select the desired custom index by pressing the corresponding numeric button 1 through 10.

#### To play repeatedly between adjacent indexes

Press REPEAT between steps 1 and 2 above. To cancel repeat play, press REPEAT again.

### c) To access an index during play

- 1 Press C.INDEX
- 2 Press / on the remote commander.
  - : Accesses the next index.
  - : Returns to the preceding index.  
(to go further back, use the numeric button.)

#### To release play using custom indexes

Press one of the PLAY MODE buttons (PROGRAM, SHUFFLE or CONTINUE). The music calendar appears.

#### Recommended application of custom indexes

When the selections on your disc are symphonies or concertos, their selection number is not useful for locating their chapters. In this case, you are recommended to assign a custom index to each chapter so that you can locate it easily. When you want to play only one chapter, you are recommended to choose Custom Index 1 (Single).

## Clearing Custom Indexes

### 1 Press C.INDEX.

C.INDEX appears.

### 2 Press CHECK.

Each time you press CHECK, index number flashes. Select the index number you want to erase.

### 3 Press ERASE while index number flashes.



The specified index will be erased and the succeeding index numbers will move up one.

# Keeping the Program in Memory – Program Bank

After programming selections, you can keep the program memorized, so that the disc is played always in the fixed order. The memorized program is called "program bank". One program bank can be made for a disc.

## Memorizing Program

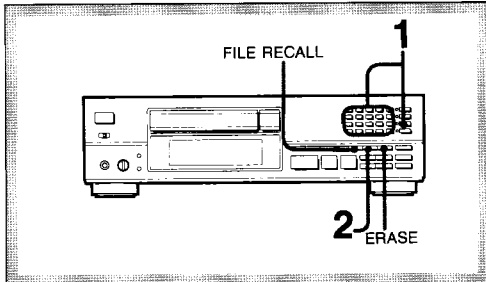

**1** Program the selections (page 18 or 22).

**2** Press FILE.

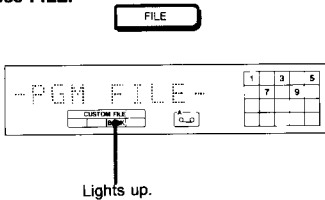

When "BANK" appears, the program is memorized for the program bank.

### To change the program bank

Program the selections again and press FILE.

#### Note

You cannot keep the multi-disc program in memory.

#### Where is the program bank memorized?

The program bank is memorized in the player's memory. Therefore, if a disc for which you made a program bank is used with another player, play using the program bank is not possible.

## Playing the Disc Using the Program Bank

### Before inserting a disc

**1** Press PROGRAM.

The indicator on the left side of the PROGRAM button lights up.

**2** Insert the disc in the tray.

**3** Press ►.

### When the disc is in the tray

**1** Press FILE RECALL during stop.

Program play mode indicator lights up and the memorized program will be recalled.

**2** Press ►.

### To play the selections in another program without clearing the program bank

Put the disc in the tray, press PROGRAM to program the selections as you want, and press ►. The disc will be played in the newly programmed order. The memorized program bank won't be cleared. (Press FILE RECALL to check the program bank.)

### To play a disc having a program bank in other modes

Put the disc in the tray, set the player in the desired play mode and press ►.

## Clearing the Program Bank

**1** Insert the disc whose program bank is to be cleared in the tray.

**2** Press FILE RECALL.

**3** Press ERASE.

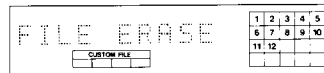

When "FILE ERASE" is displayed and "BANK" disappears, the program bank is cleared.

# Keeping Your Undesired Selections in Memory

## - Delete Bank

After choosing undesired selections, you can store them in the memory. These memorized undesired selections are called "Delete Bank". One delete bank can be made for each disc. Note that both program bank and delete banks cannot be made for one disc.

### Memorizing Desired Selection

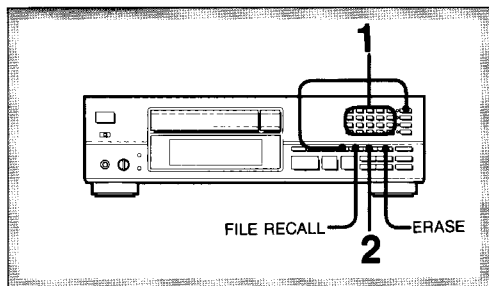

**1** Select the undesired selections. (see page 15.)

**2** Press FILE during stop.

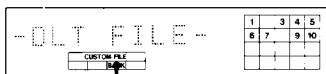

Lights up.

When "BANK" appears, the desired selections is memorized for the delete bank.

### To change the delete bank

Select the undesired selections again, and press FILE.

### Note on delete banks

- Up to 99 selections can be specified in the delete bank. However, a delete bank will not register if no selections are deleted at all.
- You cannot store a delete bank along with a program bank for a single disc.

### Where is the delete bank memorized?

The delete bank is memorized in the compact disc player's memory. Therefore, if a disc for which you made a delete bank is used with another compact disc player, play using the delete bank is not possible.

### Playing the Disc Using the Delete Bank

Before inserting a disc

**1** Press CONTINUE or SHUFFLE.

**2** Insert the disc in the tray.

**3** Press ►.

When the disc is in the compartment

**1** Press CONTINUE or SHUFFLE.

**2** Press FILE RECALL during stop.

**3** Press ►.

To play the selections in another desired selections without clearing the delete bank

Insert the disc in the tray, press ■. Select the undesired selections again, and press ►. The disc will be played in the order newly chosen. The memorized delete bank won't be cleared. (Press FILE RECALL to check the delete bank.)

To play a disc having a delete bank in other modes

Insert the disc in the tray, set the player in the desired play mode and press ►.

### Clearing the Delete Bank

**1** Insert the disc whose delete bank is to be cleared in the tray.

**2** Press FILE RECALL.

**3** Press ERASE.

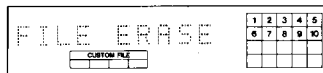

When "FILE ERASE" is displayed and "BANK" disappears, the delete bank is cleared.

# Timer Activated Playing

By connecting a commercially available timer, disc play of the desired play mode can be started at any desired time.

## Connection and Operation

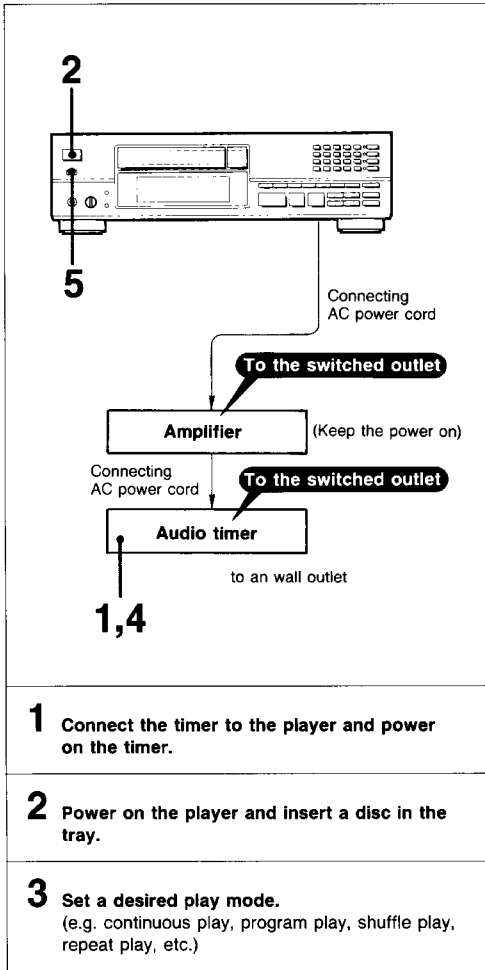

**1** Connect the timer to the player and power on the timer.

**2** Power on the player and insert a disc in the tray.

**3** Set a desired play mode.  
(e.g. continuous play, program play, shuffle play, repeat play, etc.)

**4** Set the timer to a desired play start time.

**5** Set **TIMER** to the **PLAY** position.

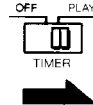

Play will start at the registered time.

### Keep the **POWER** switch depressed on the player

When the timer is set, the power of the player will be cut off.

However, be sure to leave the **POWER** switch on.

### When the timer-activated play ends

Be sure to set **TIMER** to **OFF**. If the **TIMER** switch is left at **PLAY**, the player will automatically start playing the next time the power is turned on.

### To play in the program play mode

Make a program bank (page 36) and then prepare for timer activated playing.

### If you select the custom index play mode

Play begins from custom index 1.

# Maintenance

## Cleaning Your Player

Clean the cabinet, panel and controls with a soft cloth lightly moistened with a mild detergent solution. Do not use any type of abrasive pad, scouring powder or solvent such as alcohol or benzene.

## Cleaning Discs

When a disc becomes dirty, clean it with a cleaning cloth. Wipe the disc from the center out.

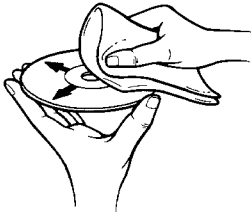

Do not use solvents such as benzene, thinner, commercially available cleaners or anti-static spray intended for analog discs.

# Specifications

## Compact disc player

Laser	Semiconductor laser ( $\lambda = 780 \text{ nm}$ ) Emission duration: continuous
Laser output	Max. $44.6 \mu\text{W}^*$ * This output is the value measured at a distance of about 200 mm from the objective lens surface on the Optical Pick-up Block.
Frequency response	2 Hz – 20 kHz $\pm 0.3 \text{ dB}$
Signal to noise ratio	CDP-X339ES More than 116 dB CDP-X229ES More than 115 dB
Dynamic range	More than 100 dB
Harmonic distortion	CDP-X339ES Less than 0.0018% CDP-X229ES Less than 0.0023%
Channel separation	More than 110 dB

## Outputs

LINE OUT (FIXED) (phone jacks)	Output level 2 V (at 50 kilohms) Load impedance over 10 kilohms
LINE OUT (VARIABLE) (phone jacks)	Output level max. 2 V (at 50 kilohms) Load impedance over 50 kilohms
DIGITAL OUTPUT (OPTICAL) (optical output connector)	Wave length 660 nm Output level –18 dBm
HEADPHONES (stereo phone jack)	Output level max. 28 mW Load impedance 32 ohms

## General

Power requirements	120 V AC, 60 Hz
Power consumption	CDP-X339ES 23 W CDP-X229ES 15 W
Dimensions	CDP-X339ES Approx. $470 \times 125 \times 375 \text{ mm}$ (w/h/d) ( $18\frac{5}{8} \times 5 \times 14\frac{7}{8}$ inches) CDP-X229ES Approx. $430 \times 110 \times 340 \text{ mm}$ (w/h/d) ( $17 \times 4\frac{3}{8} \times 13\frac{1}{2}$ inches) Including projecting parts and controls
Weight	CDP-X339ES Approx. 12 kg (26 lbs 8 oz), net CDP-X229ES Approx. 6.2 kg (13 lbs 11 oz), net

## Remote commander

Remote control system	Infrared control
Power requirements	3 V DC with two batteries size AA (IEC designation R6)
Dimensions	Approx. $62 \times 18 \times 175 \text{ mm}$ (w/h/d) ( $2\frac{1}{2} \times \frac{29}{32} \times 7$ inches)
Weight	130 g (4.6 oz) Including batteries

## Supplied accessories

Connecting cord (1)  
(2 phono plugs  $\leftrightarrow$  2 phono plugs)  
Remote commander (1)  
Sony SUM-3 (NS) batteries (2)  
Screws (8) (CDP-X339ES only)

## Optional accessory

Audio optical connecting cord POC-15

Design and specifications are subject to change without notice.

# Troubleshooting Guide

Before going through the check list below, first refer back to the connections and operating procedures.

Should any problem persist after you have made these checks, consult your nearest Sony service facility.

Symptom	Cause	Remedy
<b>The disc tray does not close.</b>	The disc is not placed correctly.	Place the disc correctly on the disc tray.
<b>Play does not start.</b>	Dirty disc.	Clean the disc.
	The disc is inserted upside down.	Insert the disc with the printed side up.
	The player is in the pause mode.	Press <b>II</b> or <b>▶</b> to release pause.
	Moisture condensation.	Leave the player turned on for approximately one hour.
<b>"-NO DISC-" is displayed.</b>	There is no disc in the player.	Insert a disc.
<b>Play begins only by turning on the power.</b>	The TIMER switch is set to PLAY.	Set the TIMER switch to OFF.
<b>Display window does not illuminate even when the power is turned on.</b>	DISPLAY MODE was pressed.	Press the button again.
<b>Sound is not heard.</b>	Loose connection.	Insert the plug firmly.
	Connection is incorrect.	Check the connection referring to "Connecting an Amplifier Directly".
	The LINE OUT/PHONE LEVEL control is set to the minimum.	Turn the control clockwise.
<b>Play does not begin from the first selection.</b>	The player is in the PROGRAM, or SHUFFLE or C.INDEX mode.	Press CONTINUE.
<b>"-OVER-" is displayed.</b>	<b>▶▶</b> was continuously pressed at the end of the disc.	Press <b>◀◀</b> or <b>◀◀▶▶</b> to return to normal indication.
<b>The remote commander does not operate the player.</b>	The batteries are run down.	Replace both batteries.
	The remote commander is not pointed at the remote sensor.	Point the remote commander at the sensor.
	There is an obstacle between the remote commander and the player.	Remove the obstacle.
	The remote commander is too far from the player.	Move closer.
<b>Any operation is not possible.</b>	The internal control program may not run.	Turn off the power and turn it on again.