

OPERATOR's MANUAL

Model 39

**30 MS/s Universal
Waveform Generator**

© 1997 Wavetek Ltd

This document contains information proprietary to Wavetek and is provided solely for instrument operation and maintenance. The information in this document may not be duplicated in any manner without the prior approval in writing from Wavetek.

Wavetek Ltd
Hurricane Way
Norwich Airport Industrial Estate
Norwich, Norfolk NR6 6JB, U.K.

Tel: 44 1603 404 824
Fax: 44 1603 483 670



Manual Issue 2, April 99
Manual Part Number: 850317-1

Contents

Introduction	3
Specifications	4
Safety	10
EMC	11
Installation	11
Connections	13
Front Panel Connections	13
Rear Panel Connections	14
General	16
Initial Operation	16
Principles of Operation	18
Standard Waveform Operation	20
Setting Generator Parameters	20
Warnings and Error Messages	23
SYNC Output	24
Sweep Operation	25
General	25
Setting Sweep Parameters	26
Triggered Burst and Gate	29
General	29
Triggered Burst	30
Gated Mode	31
Sync Out in Triggered Burst and Gated Mode	31
Tone Mode	32
Other Modulation Modes	34
External VCA	34
External SUM In	34
Arbitrary Waveform Generation	36
Introduction	36
Creating New Waveforms	37
Modifying Arbitrary Waveforms	38
Arbitrary Waveform Sequence	43
Frequency and Amplitude Control with Arbitrary Waveforms	44
Sync Out Settings with Arbitrary Waveforms	45
Waveform Hold in Arbitrary Mode	46
Output Filter Setting	46

Pulse and Pulse-trains	47
Pulse Set-up	47
Pulse-train Setup	48
Waveform Hold in Pulse and Pulse-Train Modes	50
Synchronizing Generators	51
System Operations from the Utility Menu	53
Calibration	56
Calibration Procedure	56
Calibration Routine	57
Remote Calibration	58
Remote Operation	59
Address and Baud Rate Selection	59
Remote/Local Operation	59
RS232 Interface	59
GPIB Interface	62
Power on Settings	64
Status Reporting	64
RS232 Remote Command Formats	67
GPIB Remote Command Formats	67
Remote Commands	69
Frequency and Period	69
Amplitude and DC Offset	69
Waveform Selection and Definition	70
Waveform Sequence Control	71
Arbitrary Waveform Editing	72
Mode Commands	73
Input/Output control	73
Status Commands	74
Miscellaneous Commands	75
Remote Command Summary	76
Appendix 1. Warning and Error Messages	80
Appendix 2. SYNC OUT Automatic Settings	83
Appendix 3. Factory System Defaults	84

Introduction

This Synthesized Programmable Arbitrary Waveform Generator uses a combination of direct digital synthesis and phase lock loop techniques to provide high performance and extensive facilities in a compact instrument. It can generate a wide variety of waveforms between 0-1mHz and 15MHz with high resolution and accuracy.

Arbitrary waveforms may be defined with 12 bit vertical resolution and from 4 to 65536 horizontal points. In addition a number of standard waveforms are available including sine, square, triangle, ramp and pulse.

Arbitrary waveforms may be replayed at a user specified waveform frequency or period, or the sample rate may be defined in terms of period or frequency.

Extensive waveform editing features between defined start and end points are incorporated, including waveform insert, point edit, line draw, amplitude adjust and invert. The Model 39 is also supported by Wavetek's WaveForm DSP2 arbitrary waveform creation software, which can download waveforms via the RS232 or GPIB interfaces.

Up to 50 waveforms may be stored with the length and name specified by the user. Waveforms may be strung together to form a sequence of up to four steps. Each waveform may have a user defined repeat count from 1 to 32768.

All waveforms can be swept over their full frequency range at a rate variable between 30 milliseconds and 15 minutes. Sweep can be linear or logarithmic, single or continuous. Single sweeps can be triggered from the front panel, the trigger input, or the digital interfaces. A sweep marker is provided.

Amplitude Modulation is available for all waveforms and is controlled from an external generator via the Ext VCA input.

All waveforms are available as a Triggered Burst whereby each active edge of the trigger signal will produce one burst of the carrier. The number of cycles in the burst can be set between 1 and 1048575. The Gated mode turns the output signal On when the gating signal is true and Off when it is false. Both Triggered and Gated modes can be operated from the internal Trigger Generator (0.005Hz to 50kHz), from an external source (dc to 1MHz) or by a key press or remote command.

The signals from the REF IN/OUT socket and the SYNC OUT socket can be used to phase lock two or more generators. This can be used to generate multi-phase waveforms or locked waveforms of different frequencies.

The generator parameters are clearly displayed on a backlit LCD with 4 rows of 20 characters. Soft-keys and sub menus are used to guide the user through even the most complex functions.

All parameters can be entered directly from the numeric keypad. Alternatively most parameters can be incremented or decremented using the rotary control. This system combines quick and easy numeric data entry with quasi-analog adjustment when required.

The generator has, as standard, both RS-232 and GPIB interfaces which can be used for remote control of all of the instrument functions or for the down-loading of arbitrary waveforms; the GPIB interface conforms to IEEE-488.2.

Specifications

Specifications apply at 18-28°C after one hour warm-up, at maximum output into 50Ω.

WAVEFORMS

Standard Waveforms

Sine, square, triangle, DC, positive ramp, negative ramp, sin(x)/x, pulse, pulse train, cosine, haversine and havercosine.

Sine, Cosine, Haversine, Havercosine

Range:	0.1 mHz to 10 MHz.
Resolution:	0.1mHz (7 digits)
Accuracy:	10 ppm for 1 year.
Temperature Stability:	Typically <1 ppm/°C
Output Level:	5mV to 20V pk-pk from 50Ω.
Harmonic Distortion:	<0.1% THD to 100kHz; <-65dBc to 20kHz, <-50dBc to 1MHz, <-35dBc to 10MHz.
Non-harmonic Spuri:	<-65dBc to 1MHz, <-65dBc + 6dB/octave 1MHz to 10MHz.

Square

Range:	1 mHz to 15MHz.
Resolution:	1mHz (4 digits)
Accuracy:	± 1 digit of setting.
Output Level:	5mV to 20V pk-pk from 50Ω.
Rise and Fall Times:	<25ns

Triangle

Range:	0.1 mHz to 100kHz.
Resolution:	0.1mHz (7 digits)
Accuracy:	10 ppm for 1 year.
Output Level:	5mV to 20V pk-pk from 50Ω.
Linearity Error:	<0.1% to 30 kHz

Ramps and Sin(x)/x

Range:	0.1 mHz to 100kHz.
Resolution:	0.1mHz (7 digits)
Accuracy:	10 ppm for 1 year.
Output Level:	5mV to 20V pk-pk from 50Ω.
Linearity Error:	<0.1% to 30 kHz

Pulse and Pulse Train

Output Level:	5mV to 20V pk-pk from 50Ω.
Rise and Fall Times:	<25ns

Period:

Range: 133-3ns to 100s.
Resolution: 4-digit.
Accuracy: ± 1 digit of setting.

Delay:

Range: -99-9s to + 99-99s
Resolution: 0-002% of period or 33-33ns, whichever is greater.

Width:

Range: 33-3ns to 99-99s
Resolution: 0-002% of period or 33-33ns, whichever is greater.

Note that the pulse width and absolute value of the delay may not exceed the pulse period at any time.

Pulse trains of up to 10 pulses may be specified, each pulse having independently defined width, delay and level. The baseline voltage is separately defined and the sequence repetition rate is set by the pulse train period.

Arbitrary

Up to 50 user defined waveforms may be stored in RAM. Waveforms can be defined by front panel editing controls or by downloading of waveform data via RS232 or GPIB.

Waveform Memory Size: 64k points. Maximum waveform size is 64k points, minimum waveform size is 4 points.

Vertical Resolution: 12 bits
Sample Clock Range: 100mHz to 30MHz
Resolution: 4 digits
Accuracy: ± 1 digit of setting.

Sequence

Up to 4 waveforms may be linked. Each waveform can have a loop count of up to 32768. A sequence of waveforms can be looped up to 1048575 times or run continuously.

Output Filter

Selectable between 10MHz Elliptic, 10MHz Bessel, or None.

OPERATING MODES

Triggered Burst

Each active edge of the trigger signal will produce one burst of the waveform, starting and stopping at the waveform position specified by the sync marker setting.

Carrier Waveforms: All standard and arbitrary
Number of Cycles: 1 to 1048575
Trigger Repetition Rate: dc to 50 kHz internal, dc to 1MHz external.
Source: Internal from keyboard or trigger generator.
External from TRIG IN or remote interface.

Gated

Waveform will run while the Gate signal is true and stop while false.

Carrier Waveforms:	All standard and arbitrary.
Trigger Repetition Rate:	dc to 50 kHz internal, dc to 1 MHz external.
Gate Signal Source:	Internal from keyboard or trigger generator. External from TRIG IN or remote interface.

Sweep

Capability provided for both standard and arbitrary waveforms. Arbitrary waveforms are expanded or condensed to exactly 4096 points and DDS techniques are used to perform the sweep.

Carrier Waveforms:	All standard and arbitrary except pulse, pulse train and sequence.
Sweep Mode:	Linear or logarithmic, up or down, triggered or continuous.
Sweep Range:	From 1mHz to 10 MHz in one range. Phase continuous. Independent setting of the start and stop frequency.
Sweep Time:	30ms to 999s (3 digit resolution).
Marker:	Variable during sweep.
Sweep Trigger Source:	The sweep may be free run or triggered from the following sources: Manually from keyboard. Externally from TRIG IN input or remote interface.
Sweep Hold:	Sweep can be held and restarted by the HOLD key.

Tone

Capability provided for both standard and arbitrary waveforms. Arbitrary waveforms are expanded or condensed to exactly 4096 points and DDS techniques are used to allow instantaneous frequency switching.

Carrier Waveforms:	All waveforms except pulse, pulse train and sequence.
Frequency List:	Up to 16 frequencies from 1mHz to 10MHz.
Switching Sources:	External trigger input. A true level will output the tone, a false level will stop the tone and switch to the next frequency on the list ready for the next true level.
Min. switch time:	20ms per tone.

Using 2 instruments with their outputs summed together it is possible to generate DTMF test signals.

External Amplitude Modulation

Carrier frequency:	Entire range for selected waveform.
Carrier waveforms:	All standard and arbitrary waveforms
Modulation source:	VCA/SUM IN socket.
Frequency Range:	DC - 100 kHz.
Signal Range:	Approximately 2.5V pk-pk for 100% level change at maximum output.

External Signal Summing

Carrier frequency:	Entire range for selected waveform.
Carrier waveforms:	All standard and arbitrary waveforms.
Sum source:	VCA/SUM IN socket.
Frequency Range:	DC to 10MHz.
Signal Range:	Approximately 5Vpk-pk input for 20Vpk-pk output.

Trigger Generator

Internal source 0.005 Hz to 50kHz squarewave adjustable in 20us steps. 3 digit resolution. Available for external use from the SYNC OUT socket.

OUTPUTS

Main Output

Output Impedance:	50Ω
Amplitude:	5mV to 20V pk-pk open circuit (2.5mV to 10V pk-pk into 50Ω). Amplitude can be specified open circuit (hi Z) or into an assumed load of 50Ω or 600Ω in Vpk-pk, Vrms or dBm.
Amplitude Accuracy:	2% +/-1mV at 1kHz into 50Ω.
Amplitude Flatness:	+/-0.2dB to 200 kHz; +/-1dB to 5 MHz; +/-2dB to 10 MHz.
DC Offset Range:	+/-10V. DC offset plus signal peak limited to +/-10V from 50Ω.
DC Offset Accuracy:	Typically 3% +/-10mV, unattenuated.
Resolution:	3 digits or 1mV for both Amplitude and DC Offset.

Sync Out

Multifunction output user definable or automatically selected to be any of the following:

Waveform Sync: (all waveforms)	A square wave with 50% duty cycle at the main waveform frequency, or a pulse coincident with the first few points of an arbitrary waveform.
Position Markers: (Arbitrary only)	Any point(s) on the waveform may have associated marker bit(s) set high or low.
Burst Done:	Produces a pulse coincident with the last cycle of a burst.
Sequence Sync:	Produces a pulse coincident with the end of a waveform sequence.
Trigger:	Selects the current trigger signal. Useful for synchronizing burst or gated signals.
Sweep Sync:	Outputs a pulse at the start of sweep to synchronize an oscilloscope or recorder.
Phase Lock Out:	Used to phase lock two or more generators. Produces a positive edge at the 0° phase point.
Output Signal Level:	TTL/CMOS logic levels from typically 50Ω.

Cursor/Marker Out

Adjustable output pulse for use as a marker in sweep mode or as a cursor in arbitrary waveform editing mode. Can be used to modulate the Z-axis of an oscilloscope or be displayed on a second 'scope channel.

Output Signal Level: Adjustable from nominally 2V to 14V, normal or inverted; adjustable width as a cursor.
Output Impedance: 600 Ω typical

INPUTS

Trig In

Frequency Range: DC - 1MHz.
Signal Range: Threshold nominally TTL level; maximum input +/-10V.
Minimum Pulse Width: 50ns, for Trigger and Gate modes; 50us for Sweep mode; 20ms for Tone mode.
Input Impedance: 10k Ω

VCA In

Frequency Range: DC - 100kHz.
Signal Range: 2.5V for 100% level change at maximum output.
Input Impedance: Typically 6k Ω .

Sum In

Frequency Range: DC - 10MHz.
Signal Range: Approximately 5Vpk-pk input for 20Vpk-pk output.
Input Impedance: Typically 1k2 Ω .

Hold

Holds an arbitrary waveform at its current position. A TTL low level or switch closure causes the waveform to stop at the current position and wait until a TTL high level or switch opening which allows the waveform to continue. The front panel HOLD key or remote command may also be used to control the Hold function. While held a rising edge at TRIG IN will return the waveform to the start. The front panel MAN/SYNC key or remote command may also be used to return the waveform to the start.

Input Impedance: 10k Ω

Ref Clock In/Out

Set to Input: Input for an external 10MHz reference clock. TTL/CMOS threshold level.
Set to Output: Buffered version of the internal 10MHz clock. Output levels nominally 1V and 4V from 50 Ω .
Set to Phase Lock: Used together with SYNC OUT on a master and the TRIG IN on a slave to synchronize (phase lock) multiple instruments.

INTERFACES

Full remote control facilities are available through the RS232 and GPIB interfaces.

RS232: Variable Baud rate, 9600 Baud maximum. 9-pin D-connector.
IEEE-488: Conforms with IEEE488.1 and IEEE488.2

GENERAL

Display: 20 character x 4 row alphanumeric LCD.
Data Entry: Keyboard selection of mode, waveform etc.; value entry direct by numeric keys or by rotary control.
Stored Settings: Up to 9 complete instrument set-ups may be stored and recalled from battery-backed memory. Up to 50 arbitrary waveforms can also be stored independent of the instrument settings.
Size: 3U (130mm) height; half-rack (212mm) width; 330mm long.
Weight: 4.1kg. (9lb.)
Power: 230V, 115V or 100V nominal 50/60Hz, adjustable internally; operating range +/-14% of nominal; 40VA max. Installation Category II.
Operating Range: +5°C to 40°C, 20-80% RH.
Storage Range: -20°C to + 60°C.
Environmental: Indoor use at altitudes up to 2000m, Pollution Degree 1.
Options: 19 inch rack mounting kit.
Safety: Complies with EN61010-1.
EMC: Complies with EN50081-1 and EN50082-1.

Safety

This generator is a Safety Class I instrument according to IEC classification and has been designed to meet the requirements of EN61010-1 (Safety Requirements for Electrical Equipment for Measurement, Control and Laboratory Use). It is an Installation Category II instrument intended for operation from a normal single phase supply.

This instrument has been tested in accordance with EN61010-1 and has been supplied in a safe condition. This instruction manual contains some information and warnings which have to be followed by the user to ensure safe operation and to retain the instrument in a safe condition.

This instrument has been designed for indoor use in a Pollution Degree 1 environment (no pollution, or only dry non-conductive pollution) in the temperature range 5°C to 40°C, 20% - 80% RH (non-condensing). It may occasionally be subjected to temperatures between +5° and -10°C without degradation of its safety.

Use of this instrument in a manner not specified by these instructions may impair the safety protection provided. Do not operate the instrument outside its rated supply voltages or environmental range. In particular excessive moisture may impair safety.

WARNING! THIS INSTRUMENT MUST BE EARTHED

Any interruption of the mains earth conductor inside or outside the instrument will make the instrument dangerous. Intentional interruption is prohibited. The protective action must not be negated by the use of an extension cord without a protective conductor.

When the instrument is connected to its supply, terminals may be live and opening the covers or removal of parts (except those to which access can be gained by hand) is likely to expose live parts. The apparatus shall be disconnected from all voltage sources before it is opened for any adjustment, replacement, maintenance or repair.

Any adjustment, maintenance and repair of the opened instrument under voltage shall be avoided as far as possible and, if inevitable, shall be carried out only by a skilled person who is aware of the hazard involved.

If the instrument is clearly defective, has been subject to mechanical damage, excessive moisture or chemical corrosion the safety protection may be impaired and the apparatus should be withdrawn from use and returned for checking and repair.

Make sure that only fuses with the required rated current and of the specified type are used for replacement. The use of makeshift fuses and the short-circuiting of fuse holders is prohibited.

This instrument uses a Lithium button cell for non-volatile memory battery back-up; typical life is 5 years. In the event of replacement becoming necessary, replace only with a cell of the correct type, i.e. 3V Li/MnO₂ 20mm button cell type 2032. Exhausted cells must be disposed of carefully in accordance with local regulations; do not cut open, incinerate, expose to temperatures above 60°C or attempt to recharge.

Do not wet the instrument when cleaning it and in particular use only a soft dry cloth to clean the LCD window. The following symbols are used on the instrument and in this manual:-



Caution -refer to the accompanying documentation, incorrect operation may damage the instrument.



terminal connected to chassis ground.



mains supply OFF.



mains supply ON.



alternating current.

EMC

This generator has been designed to meet the requirements of the EMC Directive 89/336/EEC. Compliance was demonstrated by meeting the test limits of the following standards:

Emissions

EN50081-1 (1992) Generic emission standard for residential commercial and light industry. Test methods and limits used were:

- a) EN55022 Conducted, Class B
- b) EN55022 Radiated, Class B

Immunity

EN50082-1 (1992) Generic immunity standard for residential, commercial and light industry. Test methods and limits used were:

- a) EN60801-2 (1993) Electrostatic Discharge, 8 kV air discharge.
- b) IEC801-3 (1984) RF Field, 3 V/m.
- c) IEC801-4 (1988) Fast Transient, 1 kV peak (AC line), 0.5kV peak (signal lines and RS232/GPIB ports).

Cautions

To ensure continued compliance with the EMC directive the following precautions should be observed:

- a) connect the generator to other equipment using only high quality, double-screened cables.
- b) after opening the case for any reason ensure that all signal and ground connections are remade correctly before replacing the cover. Always ensure all case screws are correctly refitted and tightened.
- c) In the event of part replacement becoming necessary, only use components of an identical type, see the Service Manual.

Installation

Check that the instrument operating voltage marked on the rear panel is suitable for the local supply. Should it be necessary to change the operating voltage, proceed as follows:

- 1) Disconnect the instrument from all voltage sources.
- 2) Remove the screws which retain the top cover and lift off the cover.
- 3) Change the transformer connections as follows:
 - for 230V operation connect the live (brown) wire to pin 15
 - for 115V operation connect the live (brown) wire to pin 14
 - for 100V operation connect the live (brown) wire to pin 13
- 4) Refit the cover and the secure with the same screws.
- 5) To comply with safety standard requirements the operating voltage marked on the rear panel must be changed to clearly show the new voltage setting.
- 6) Change the fuse to one of the correct rating, see below.

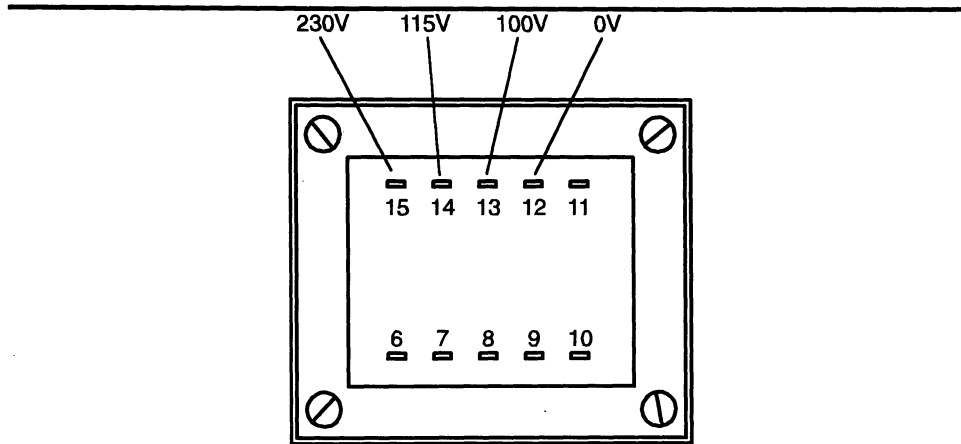

Fuse

Ensure that the correct mains fuse is fitted for the set operating voltage. The correct mains fuse types are:

- for 230V operation: 250 mA (T) 250 V HRC
- for 100V or 115V operation: 500 mA (T) 250 V HRC

To replace the fuse, disconnect the mains lead from the inlet socket and release the fuse drawer below the socket pins by depressing both clips together, with miniature screwdrivers, so that the drawer can be eased open. Change the fuse and replace the drawer.

The use of makeshift fuses or the short-circuiting of the fuse holder is prohibited.

Mains Lead

When a three core mains lead with bare ends is provided it should be connected as follows:-

- Brown - Mains Live**
- Blue - Mains Neutral**
- Green / Yellow - Mains Earth**

WARNING! THIS INSTRUMENT MUST BE EARTHED

Any interruption of the mains earth conductor inside or outside the instrument will make the instrument dangerous. Intentional interruption is prohibited. The protective action must not be negated by the use of an extension cord without a protective conductor.

Mounting

This instrument is suitable both for bench use and rack mounting. It is delivered with feet for bench mounting. The front feet include a tilt mechanism for optimal panel angle.

A rack kit for mounting one or two of these Half-width 3U high units in a 19" rack is available from the Manufacturers or their overseas agents.

Connections

Front Panel Connections

MAIN OUT

This is the 50 Ω output from the main generator. It will provide up to 20V peak-to-peak e.m.f. which will yield 10V peak-to-peak into a matched 50 Ω load. It can tolerate a short circuit for 60 seconds.



Do not apply external voltages to this output.

SYNC OUT

This is a TTL/CMOS level output which may be set to any of the following signals from the SYNC OUTPUT SET-UP screen.

WAVEFORM SYNC	A sync marker phase coincident with the MAIN OUT waveform. For standard waveforms, (sine, cosine, haversines, square, triangle, $\sin x/x$ and ramp), the sync marker is a squarewave with a 1:1 duty cycle with the rising edge at the 0 $^\circ$ phase point and the falling edge at the 180 $^\circ$ phase point. For arbitrary waveforms the sync marker is a positive pulse coincident with the first few points (addresses) of the waveform. In a sequence each waveform in the sequence generates its own sync marker.
POS'N MARKER	When position (pos'n) marker is selected, the instrument generates a pulse marker pattern for arbitrary waveforms. The pulse pattern is programmable from the "edit waveform" menu on the MODIFY screen.
BURST DONE	Provides a signal during Gate or Trigger modes which is low while the waveform is active at the main output and high at all other times.
SEQUENCE SYNC	Provides a signal which is low during the last cycle of the last waveform in a sequence and high at all other times.
TRIGGER	Provides a positive going version of the actual trigger signal; internal external, manual and remote all produce a trigger sync.
SWEEP SYNC	Goes high at the start of the sweep and low at the end of the sweep
PHASE LOCK	Produces a positive edge coincident with the start of the current waveform; this is used for phase locking instruments. This waveform may not appear coherent.

SYNC OUT logic levels are nominally 0V and 5V from typically 50 Ω . SYNC OUT will withstand short circuit.



Do not apply external voltage to this output.

TRIG IN

This is the external input for Trigger, Gate, Sweep and Sequence operations. It is also the input used to synchronize the generator (as a slave) to another (which is the master).



Do not apply external voltages exceeding $\pm 10V$.

VCA/SUM IN

This is the input socket for external voltage controlled amplitude (VCA) or external signal summing (SUM). The function of this input is selected from the EXT SUM/VCA SET-UP screen. For VCA operation the input impedance is nominally 6k Ω and for SUM operation it is nominally 1k2 Ω .



Do not apply external voltages exceeding $\pm 10V$.

Rear Panel Connections

REF CLOCK IN/OUT

The function of the CLOCK IN/OUT socket is set from the "ref clock i/o" menu on the UTILITY screen, see System Operations section.

INPUT This is the default setting. The socket becomes an input for an external 10MHz reference clock. The system automatically switches over from the internal clock when the external reference is applied.

OUTPUT The internal 10MHz clock is made available at the socket.

PHASE LOCK When two or more generators are synchronized the slaves are set to PHASE LOCK SLAVE and the master is set to PHASE LOCK MASTER.

As an output the logic levels are nominally 1V and 4V from typically 50 Ω . CLOCK OUT will withstand a short-circuit. As an input the threshold is TTL/CMOS compatible.



Do not apply external voltages to this output exceeding +7.5 V or -2.5 V.

HOLD IN

Controls the waveform hold function. The input impedance is nominally 10k Ω .



Do not apply external voltages exceeding $\pm 10V$.

CURSOR/MARKER OUT

Output pulse for use as a marker in sweep mode or as a cursor in arbitrary waveform editing mode. Can be used to modulate the Z-axis of an oscilloscope or be displayed on a second 'scope channel. The output impedance is nominally 600 Ω and the signal level is adjustable from 2V-14V nominal from the "cursor/marker" menu on the UTILITY screen, see System Operations section.



Do not apply external voltages to this input.

RS232

9-pin D-connector compatible. The pin connections are shown below:

Pin	Name	Description
1	-	No internal Connection
2	TXD	Transmitted data from instrument
3	RXD	Received data to instrument
4	-	No internal connection
5	GND	Signal ground
6	-	No internal connection
7	RXD2	Secondary received data
8	TXD2	Secondary transmitted data
9	GND	Signal ground

Pin 2, 3 and 5 may be used as a conventional RS232 interface with XON/XOFF handshaking. Pins 7,8 and 9 are additionally used when the instrument is used in addressable RS232 mode. Signal grounds are connected to instrument ground. The RS232 address is set from the "remote" menu on the UTILITY screen, see System Operations section.

GPIB (IEEE-488)

The GPIB interface is not isolated; the GPIB signal grounds are connected to the instrument ground.

The implemented subsets are:

SH1 AH1 T6 TE0 L4 LE0 SR1 RL1 PP1 DC1 DT1 C0 E2

The GPIB address is set from the "remote" menu on the UTILITY screen, see System Operations section.

Initial Operation

This section is a general introduction to the organization of the instrument and is intended to be read before using the generator for the first time. Detailed operation is covered in later sections starting with Standard Waveform Operation.

In this manual front panel keys and sockets are shown in capitals, e.g. CREATE, SYNC OUT; all soft-key labels, entry fields and messages displayed on the LCD are shown in a different typefont, e.g. STANDARD WAVEFORMS, sine.

Switching On

The power switch is located at the bottom left of the front panel.

At power up the generator displays the installed software revision whilst loading its waveform RAM; if an error is encountered the message SYSTEM RAM ERROR, CHECK BATTERY will be displayed, see the Warnings and Error Messages section.

Loading takes a few seconds, after which the STATUS screen is displayed, showing the generator parameters set to their default values, with the MAIN OUT set off. Refer to the Utility screen section for how to change the power up settings to either those at power down or to any one of the stored settings. Recall the STATUS screen at any time with the STATUS key; a second press returns the display to the previous screen.

Change the basic generator parameters as described in the Standard Waveform Operation section and switch the output on with the MAIN OUT key; the ON lamp will light to show that output is on.

Display Contrast

All parameter settings are displayed on the 20 character x 4 row backlit liquid crystal display (LCD). The contrast may vary a little with changes of ambient temperature or viewing angle but can be optimized for a particular environment by using the front panel contrast control. Insert a small screwdriver or trimmer tool through the adjustment aperture marked LCD and rotate the control for optimum contrast.

Keyboard

Pressing the front panel keys displays screens which list parameters or choices relative to the key pressed. Selections are then made using the display soft-keys and numeric values are changed using the numeric keys or rotary control, see the Principles of Editing section.

The keys are grouped as follows:

- WAVE SELECT keys call screens from which all standard or already defined arbitrary waveforms can be selected and from which sweep parameters can be set.
- WAVE EDIT keys call screens from which arbitrary waveforms can be created and modified and output filter selected.
- FREQUENCY, AMPLITUDE, OFFSET and MODE keys display screens which permit their respective parameters to be edited either from the numeric keypad or using the rotary control/cursor keys.
- NUMERIC keys permit direct entry of a value for the parameter currently selected. Values are accepted in three formats: integer (20), floating point (20.0) and exponential (2 exp 1). For example, to set a new frequency of 50kHz press FREQ followed by 50000 ENTER or 5 EXP 4 ENTER. ENTER confirms the numeric entry and changes the generator setting to the new value.

CE (Clear Entry) undoes a numeric entry digit by digit. ESCAPE returns a setting being edited to its last value.

- VCA/SUM IN, TRIG IN and SYNC OUT call screens from which the parameters of those input/outputs can be set, including whether the port is on or off; the MAIN OUT key simply switches the main output on or off.
- MAN/SYNC is used for manual triggering (when TRIG IN is appropriately set) and for synchronizing two or more generators when suitably connected together. HOLD is used to manually pause arbitrary waveform output and sweep; the output is held at the level it was at when HOLD was pressed.
- UTILITY gives access to menus for a variety of functions such as remote control interface set-up, power-up parameters, error message settings and store/recall waveforms to/from non-volatile memory; the RECALL key can also be used to directly access the non-volatile stores.
- Eight soft-keys around the display are used to directly set or select parameters from the currently displayed menu; their operation is described in more detail in the next section.
- The STATUS key toggles between the current display and the start-up screen which gives an overview of the generators status.

Further explanations will be found in the detailed descriptions of the generator's operation.

Principles of Editing

Each screen called up by pressing a front panel key shows parameter value(s) and/or a list of choices. Parameter values can be edited by using the ROTARY CONTROL in combination with the left and right arrowed CURSOR keys, or by direct numeric keyboard entry; choices are made using the soft-key associated with the screen item to be selected. The examples which follow assume factory default settings.

A diamond beside a screen item indicates that it is selectable; hollow diamonds identify deselected items and filled diamonds denote selected items. For example, press MODE to get the screen shown below:

```
MODE:
◆continuous
◇gated
◇triggered  setup...◇
```

The filled diamond indicates that the selected mode is `continuous`. `Gated` or `Triggered` modes are selected by pressing the associated soft-key which will make the diamond beside that item filled and the diamond beside `continuous` hollow. This screen also illustrates how an ellipsis (three dots following the screen text) indicates that a further screen follows when that item is selected. In the case of the MODE screen illustrated, pressing the `setup...` soft-key brings up the `TRIGGER SETUP` menu; note that selecting this item does not change the `continuous/gated/triggered` selection.

Some screen items are marked with a double-headed arrow (a split diamond) when selected to indicate that the item's setting can be changed by further presses of the soft-key, by pressing either cursor key or by using the rotary control. For example, pressing FILTER brings up the screen shown below.

```
FILTER SETUP
◆mode: auto
◇type: 10MHz elliptic
```

Repeated presses of the `mode` soft-key will toggle the mode between its two possible settings of `auto` and `manual`. Similarly, when `type` is selected, repeated presses of the `type` soft-key (or cursor keys or use of the rotary control) will step the selection through all possible settings of the filter type.

In addition to their use in editing items identified by a double-headed arrow as described above, the CURSOR keys and ROTARY CONTROL operate in two other modes.

In screens with lists of items that can be selected (i.e. items marked with a diamond) the cursor keys and rotary control are used to scroll all items through the display if the list has more than three items; look, for example at the STD (standard waveform) and UTILITY screens.

In screens where a parameter with a numeric value is displayed the cursor keys move the edit cursor (a flashing underline) through the numeric field and the rotary control will increment or decrement the value; the step size is determined by the position of the edit cursor within the numeric field.

Thus for `STANDARD FREQUENCY` set to `1.00000 MHz` rotating the control will change the frequency in 1kHz steps. The display will auto-range up or down as the frequency is changed, provided that autoranging permits the increment size to be maintained; this will in turn determine the lowest or highest setting that can be achieved by turning the control. In the example above, the lowest frequency that can be set by rotating the control is 1 kHz, shown on the display as `1.000000 kHz`.

This is the limit because to show a lower frequency the display would need to autorange below 1kHz to `xxx.xxxx Hz` in which the most significant digit represents 100Hz, i.e. the 1kHz increment would be lost. If, however, the starting frequency had been set to `1.000000 MHz`, i.e. a 100 Hz increment, the display would have autoranged at 1kHz to `900.0000 Hz` and could then be decremented further right down to `000.0000 Hz` without losing the 100 Hz increment.

Turning the control quickly will step numeric values in multiple increments.

Principles of Operation

The instrument operates in one of two different modes depending on the waveform selected. DDS mode is used for sine, cosine, haversine, triangle, $\sin x/x$ and ramp waveforms. Clock Synthesis mode is used for square, pulse, pulse train, arbitrary and sequence.

In both modes the waveform data is stored in RAM. As the RAM address is incremented the values are output sequentially to a Digital-to-Analog Converter (DAC) which reconstructs the waveform as a series of voltages steps which are subsequently filtered before being passed to the main output connector.

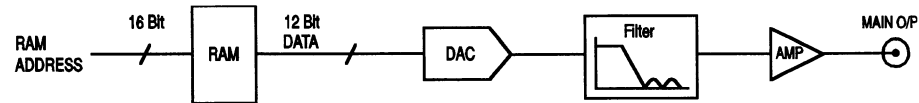

The main difference between DDS and Clock Synthesis modes is the way in which the addresses are generated for the RAM and the length of the waveform data.

Clock Synthesis Mode

In Clock Synthesis mode the addresses are always sequential (an increment of one) and the clock rate is adjusted by the user in the range 30MHz to 0.1Hz. The frequency of the waveform is clock frequency \div waveform length, thus allowing short waveforms to be played out at higher repetition rates than long waveforms, e.g. the maximum frequency of a 4 point waveform is $30e6 \div 4$ or 7.5MHz but a 1000 point waveform has a maximum frequency of $30e6 \div 1000$ or 30kHz.

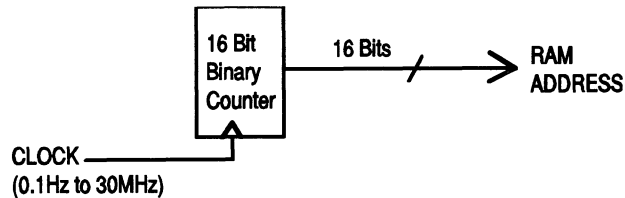

Arbitrary waveforms have a user defined length of 4 to 65536 points. Squarewaves use a fixed length of 2 points and pulse and pulse train have their length defined by the user selected period value.

DDS Mode

In DDS mode (Direct Digital Synthesis) all waveforms are stored in RAM as 4096 points. The frequency of the output waveform is determined by the rate at which the RAM addresses are changed. The address changes are generated as follows:

The RAM contains the amplitude values of all the individual points of one cycle (360°) of the waveform; each sequential address change corresponds to a phase increment of the waveform of $360^\circ/4096$. Instead of using a counter to generate sequential RAM addresses, a phase accumulator is used to increment the phase.

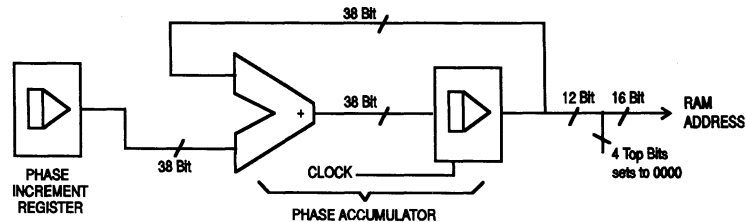

On each clock cycle the phase increment, which has been loaded into the phase increment register by the CPU, is added to the current result in the phase accumulator; the 12 most significant bits of the phase accumulator drive the lower 12 RAM address lines, the upper 4 RAM address lines are held low. The output waveform frequency is now determined by the size of the phase increment at each clock. If each increment is the same size then the output frequency is constant; if it changes, the output frequency changes as in sweep mode.

The generator uses a 38 bit accumulator and a clock frequency which is $2^{38} \times 10^{-4}$ (~27.4878 MHz); this yields a frequency resolution of 0.1 mHz.

Only the 12 most significant bits of the phase accumulator are used to address the RAM. At a waveform frequency of $F_{CLK}/4096$ (~6.7MHz), the natural frequency, the RAM address increments at every clock. At all frequencies below this (i.e. at smaller phase increments) one or more addresses are output for more than one clock period because the phase increment is not big enough to step the address at every clock. Similarly at frequencies above the natural frequency the larger phase increment causes some addresses to be skipped, giving the effect of the stored waveform being sampled; different points will be sampled on successive cycles of the waveform.

Standard Waveform Operation

This sections deals with the use of the instrument as a standard function generator, i.e. generating sine, square, triangle, dc, ramp, haversine, cosine, havercosine and $\sin x/x$ waveforms. All but squarewave are generated by DDS which gives 7-digit frequency precision; squarewave is generated by Clock Synthesis which results in only 4-digit frequency resolution. Refer to Principles of Operation in the previous section for a fuller explanation of the differences involved.

The **STANDARD WAVEFORMS** screen also includes arbitrary and sequence for simplicity of switching between these and standard waveforms; they do, however, have their own screens (accessed by pressing ARB and SEQUENCE respectively) and are described in detail in their appropriate sections. Pulse and pulse-train are also accessed from the 'standard waveforms' screen but are sufficiently different to justify their own section in the manual.

Much of the following descriptions of amplitude and offset control, as well as of Mode, Sweep, etc., in following sections, apply to arbitrary and sequence as well as standard waveforms; for clarity, any differences of operation with arbitrary, sequence, pulse and pulse-train are described only in those sections.

Setting Generator Parameters

Waveform Selection

```
STANDARD WAVEFORMS
◆sine
◇square
◇triangle
```

Pressing the STD key gives the **STANDARD WAVEFORMS** screen which lists all the waveforms available; the rotary control or cursor keys can be used to scroll the full list back and forward through the display. The currently selected waveform (sine with the factory defaults setting) is indicated by the filled diamond; the selection is changed by pressing the soft-key beside the required waveform.

Frequency

```
STANDARD FREQUENCY
  10.00000 kHz
◆freq      period◇
```

Pressing the **FREQ** key gives the **STANDARD FREQUENCY** screen. With **freq** selected as shown above, the frequency can be entered directly from the keyboard in integer, floating point or exponential format, e.g. 12.34 kHz can be entered as 12340, 12340.00, or 1.234 exp 4 etc. However, the display will always show the entry in the most appropriate engineering units, in this case 12.34000 kHz.

With **period** selected instead of **freq** the frequency can be set in terms of a period, e.g. 123.4 μ s can be entered as .0001234 or 123.4e-6; again the display will always show the entry in the most appropriate engineering units. Note that the precision of a period entry is restricted to 6 digits; 7 digits are displayed but the least significant one is always zero. The hardware is programmed in terms of frequency; when a period entry is made the synthesized frequency is the nearest equivalent value that the frequency resolution and a 6-digit conversion calculation gives. If the frequency is displayed after a period entry the value may differ from the expected value because of these considerations. Further, once the setting has been displayed as a

frequency, converting back again to display period will give an exact 6-digit equivalent of the 7-digit frequency, but this may differ from the period value originally entered.

Squarewave, generated by Clock Synthesis has 4-digit resolution for both frequency and period entry but the hardware is still programmed in terms of frequency and the same differences may occur in switching the display from period to frequency and back to period.

Turning the rotary control will increment or decrement the numeric value in steps determined by the position of the edit cursor (flashing underline); the cursor is moved with the left and right arrowed cursor keys.

Note that the upper frequency limits vary for the different waveform types; refer to the Specifications section for details.

Frequency setting for arbitrary, sequence pulse and pulse-train is explained in the relevant sections.

Amplitude

```
AMPLITUDE:
  +20.0 Vpp
◆Vpp      Vrms◇
◇dBm      load:hiZ◇
```

Pressing the AMPL key gives the **AMPLITUDE** screen.

The waveform amplitude can be set in terms of peak-to-peak Volts (Vpp), r.m.s. Volts (Vrms) or dBm (referenced to a 50Ω or 600Ω load). For Vpp and Vrms the level can be set assuming that the output is open-circuit (load:hiZ) or terminated (load:50Ω or load:600Ω); when dBm is selected termination is always assumed and the load:hiZ setting is automatically changed to load:50Ω. Note that the actual generator output impedance is always 50Ω; the displayed amplitude values for 600Ω termination take this into account.

With the appropriate form of the amplitude selected (indicated by the filled diamond) the amplitude can be entered directly from the keyboard in integer, floating point or exponential format, e.g. 250mV can be entered as .250 or 250 exp -3, etc., However, the display will always show the entry in the most appropriate engineering units, in this case 250mV.

Turning the rotary control will increment or decrement the numeric value in steps determined by the position of the edit cursor (flashing underline); the cursor is moved with the left and right arrowed cursor keys.

Alternate presses of the +/- key will invert the MAIN OUT output; if DC OFFSET is non-zero, the signal is inverted about the same offset. The exception to this is if the amplitude is specified in dBm; since low level signals are specified in -dBm (0dBm = 1mW into 50Ω = 224mVrms) the - sign is interpreted as part of a new amplitude entry and not as a command to invert the signal.

Note that for DC, sinx/x, pulse train, arbitrary and sequence amplitude can only be displayed and entered in the Vpp form; further limitations on pulse-train, arbitrary and sequence amplitude are discussed in the appropriate sections.

DC Offset

```
DC OFFSET:
  program +0.00 mVdc
  (actual +0.00 mVdc)
                load:hiZ◇
```

Pressing the OFFSET key gives the **DC OFFSET** screen. The offset can be entered directly from the keyboard in integer, floating point or exponential format, e.g. 100mV can be entered as .1 or 100 exp -3 etc. However, the display will always show the entry in the most appropriate

engineering units, in this case 100mV. During a new offset entry the +/- key can be used at any time to set the offset negative; alternate presses toggle the sign between + and –.

Turning the rotary control will increment or decrement the numeric value in steps determined by the position of the edit cursor (flashing underline); the cursor is moved by the left and right arrowed cursor keys. Because DC offset can have negative values, the rotary control can take the value below zero; although the display may autorange to a higher resolution if a step takes the value close to zero, the increment size is maintained correctly as the offset is stepped negative. For example, if the display shows

```
program = +205· mVdc
```

with the cursor in the most significant digit, the rotary control will decrement the offset in 100mV steps as follows:

```
program = +205· mVdc
```

```
program = +105· mVdc
```

```
program = +5·00 mVdc
```

```
program = -95·0 mVdc
```

```
program = -195· mVdc
```

The actual DC offset at the MAIN OUT socket is attenuated by the fixed-step output attenuator when this is in use. Since it is not obvious when the signal is being attenuated the actual offset is shown in brackets as a non-editable field below the programmed value.

For example, if the amplitude is set to 2.5Vpp the output is not attenuated by the fixed attenuator and the actual DC offset (in brackets) is the same as that set. The DC OFFSET display shows:

```
DC OFFSET:
program +150· mVdc
(actual +150· mVdc)
load:hiZ ◊
```

If the amplitude is now reduced to 250mVpp which introduces the attenuator, the actual DC offset changes by the appropriate factor:

```
DC OFFSET:
program +150· mVdc
(actual +15·1 mVdc)
load:hiZ ◊
```

The above display shows that the set DC offset is +150mV but the actual offset is +15.1mV. Note that the actual offset value also takes into account the true attenuation provided by the fixed attenuator, using the values determined during the calibration procedure. In the example displayed the output signal is 250mVpp exactly and takes account of the small error in the -20dB fixed attenuator; the offset is 15.1mV exactly, taking account of the effect of the known attenuation (slightly less than the nominal -20dB) on the set offset of 150mV.

Whenever the set DC offset is modified by a change in output level in this way a warning message that this has happened will be displayed. Similarly, because the DC offset plus signal peak is limited to ± 10V to avoid waveform clipping, a warning message will be displayed if this condition is set. This is explained more fully in the Warnings and Error Messages section.

Warnings and Error Messages

Two classes of message are displayed on the screen when an illegal combination of parameters is attempted.

WARNING messages are shown when the entered setting causes some change which the user might not necessarily expect. Examples are:

1. Changing the amplitude from, for example, 2.5 Volts pk-pk to 250mV pk-pk brings in the step attenuator; if a non-zero offset has been set then this will now be attenuated too. The message `DC OFFSET CHANGED BY AMPLITUDE` will be shown temporarily on the screen but the setting will be accepted; in this case the actual, attenuated, offset will be shown in brackets below the set value.
2. With the output level set to 10V pk-pk, increasing the DC offset beyond $\pm 5V$ will cause the message `DC OFFSET + LEVEL MAY CAUSE CLIPPING`. The offset change will be accepted (producing a clipped waveform) and the user may then choose to change the output level or the offset to produce a signal which is not clipped. `(clip?)` will show in the display beside `AMPLITUDE` or `DC OFFSET` while the clipped condition exists.

ERROR messages are shown when an illegal setting is attempted, most generally a number outside the range of values permitted. In this case the entry is rejected and the parameter setting is left unchanged. Examples are:

1. Entering a frequency of 1MHz for a triangle waveform. The error message:
`Frequency out of range for the selected waveform` is shown.
2. Entering an amplitude of 25Vpp. The error message:
`Maximum output level exceeded` is shown.
3. Entering a DC offset of 20V. The error message:
`Maximum DC offset exceeded` is shown.

The messages are shown on the display for approximately two seconds. The last two messages can be viewed again by pressing the `last error...` soft-key on the UTILITY screen, see System Operations section.

Each message has a number and the full list appears in Appendix 1.

The default set-up is for all warning and error messages to be displayed and for a beep to sound with each message. This set-up can be changed on the `error...` menu on the UTILITY screen. The `error` menu is shown below:

```
◇error beep: ON
◇error message: ON
◆warn beep: ON
◇warn message: ON
```

Each feature can be turned ON and OFF with alternate presses of the associated soft-key; the factory default is for all features to be ON. If the setting is changed and is required for future use it should be saved by changing the `POWER ON SETTING` on the `power on...` menu of the UTILITY screen to `restore last setup`.

SYNC Output

SYNC OUT is a multifunction CMOS/TTL level output that can be automatically or manually set to be any of the following:

- **Waveform Sync :** A square wave with 50% duty cycle at the main waveform frequency, or a pulse coincident with the first few points of an arbitrary waveform. Can be selected for all waveforms.
- **Position Marker :** Can be selected for arbitrary waveforms only. Any point(s) on the main waveform may have associated marker bit(s) set high or low.
- **Burst Done :** Produces a pulse coincident with the last cycle of the burst.
- **Sequence Sync :** Produces a pulse coincident with the end of a waveform sequence.
- **Trigger :** Selects the current trigger signal (internal, external or manual). Useful for synchronizing burst or gated signals.
- **Sweep Sync :** Outputs the sweep trigger signal.
- **Phase Lock :** Used to lock two or more generators. Produces a positive edge at the 0° phase point.

The setting up of the signals themselves is discussed in the relevant sections later in this manual, e.g. **Trigger** is described in the Triggered Burst/Gate section and **Position Marker** under the Arbitrary Waveform Generation.

Pressing the key above the SYNC OUT socket calls the **SYNC OUTPUT SETUP** screen.

```
SYNC OUTPUT SETUP
⚡output: on
◊mode: auto
◊src: waveform sync
```

SYNC OUT is turned on and off by alternate presses of the **output** soft-key.

The selection of the signal to be output from the SYNC OUT socket is made using the **src** (source) soft-key; repeated presses of **src** cycle the selection through all the choices (**waveform sync**, **position marker**, etc.) listed above. Alternatively, with the **src** selected (double-headed arrow) the rotary control or cursor keys can be used to step backwards and forwards through the choices.

The source selection of the SYNC OUT waveform can be made automatic (**auto**) or user-defined (**manual**) with alternate presses of the **mode** soft-key. In automatic mode the SYNC OUT waveform most appropriate for the current main waveform is selected.

For example, **waveform sync** is automatically selected for all continuous standard and arbitrary waveforms, but **trigger** is selected in trigger or gated waveform modes. The automatic selection will be mentioned in each of the appropriate main waveform mode sections and a full table is given in Appendix 2.

The automatic selection can still be changed manually by the **src** soft-key even when **auto** mode has been selected but the selection will immediately revert to the automatic choice as soon as any relevant parameter (e.g. main waveform frequency or amplitude) is adjusted. **Manual** must be selected by the **mode** soft-key for a source other than the automatic choice to remain set. The **auto** selection will generally set the most frequently used signal, e.g. **waveform sync** for all continuous main waveforms, but **manual** will need to be used for special requirements, e.g. position markers on arbitrary waveforms.

Sweep Operation

General

Principles of Sweep Operation

All standard and arbitrary waveforms can be swept with the exception of pulse, pulse-train and sequence. During Sweep all waveforms are generated in DDS mode because this offers the significant advantage of phase-continuous sweeps over a very wide frequency range (up to 10^{10}). However, it must be remembered that the frequency is actually stepped, not truly linearly swept, and thought needs to be given as to what the instrument is actually doing when using extreme combinations of sweep range and time.

For DDS operation during Sweep all waveforms must be 4096 points in length; this is the natural length for standard waveforms but all arbitrary waveforms are expanded or condensed in software to 4096 points when Sweep is turned on. This does not affect the original data.

Sweep mode is turned on and off either by the `on` or `off` soft-key on the `SWEEP SETUP` screen accessed by pressing the SWEEP front panel key, or by the `sweep` soft-key on the `MODE` screen.

When sweep is turned on the software creates a table of 2048 frequencies between, and including, the specified start and stop values. For sweep times of 1.03s and greater the sweep will step through all 2048 frequency values. Below 1.03s, however, the frequency sweep will contain fewer steps because of the minimum 0.5ms dwell at each step; at the shortest sweep time (30ms) the sweep will contain only 60 steps.

Because any frequency used in sweep mode must be one of the tabled values, the center frequency displayed (see Sweep Range) may not be the exact mid-point and markers (see Sweep Marker) may not be exactly at the programmed frequency. The frequency resolution of the steps will be particularly coarse with wide sweeps at the fastest sweep rate.

Connections for Sweep Operation. Sync Out and Trig In

Sweeps are generally used with an oscilloscope or hard-copy device to investigate the frequency response of a circuit. The MAIN OUT is connected to the circuit input and the circuit output is connected to an oscilloscope or, for slow sweeps, a recorder.

An oscilloscope or recorder can be triggered by connecting its trigger input to the generator's SYNC OUT; SYNC OUT defaults to `sweep sync` when sweep is turned on. `sweep sync` goes high at the start of sweep and low at the end of sweep. At the end of sweep it is low long enough for an oscilloscope to retrace, for example.

To show a marker on the display instrument the rear panel CURSOR/MARKER OUT socket should be connected to a second channel. Alternatively, for an oscilloscope the signal can be used to modulate the Z-axis. See Sweep Marker section for setting marker frequency. The cursor/marker polarity and level is set up on the `cursor/marker...` menu of the UTILITY screen, see System Operations section.

For triggered sweeps, a trigger signal must be provided at the front panel TRIG IN socket or by pressing the MAN/SYNC key or by a remote command. The function of TRIG IN is automatically defaulted to external when triggered sweep is selected; a sweep is initiated by the rising edge of the trigger signal.

The generator does not provide a ramp output for use with X-Y displays or recorders.

Setting Sweep Parameters

Pressing the SWEEP key (or the `sweep setup` soft-key on the `MODE` screen) displays the `SWEEP SETUP` screen.

```
SWEEP SETUP:  OFF ↕
↕range...    type... ↕
↕time...     spacing... ↕
↕manual...   marker... ↕
```

Menus for setting up the range, time (sweep rate), type (continuous, triggered, etc.) spacing (lin/log) and marker position are all accessed from this screen using the appropriate soft-key. In addition the control screen for manual sweep (i.e. sweeping using the rotary control or cursor keys) is selected from this screen and Sweep Mode itself is turned on and off with alternate presses of the `on/off` soft-key; sweep can also be turned on by the `sweep` soft-key on the `MODE` screen. On all the following menus, pressing the `done` soft-key returns the display to this `SWEEP SETUP` screen.

Sweep Range

Pressing the `range...` soft-key calls the `SWEEP RANGE` screen.

```
SWEEP RANGE:
◆start: 100.0 kHz
↕stop:  10.00 MHz
↕centr/span  done ↕
```

The maximum sweep range for all waveforms is 1mHz to 10MHz, including triangle, ramp and squarewave which have different limits in unswept operation.

Sweep range can be defined by start and stop frequencies or in terms of a center frequency and span. `start` and `stop` soft-keys permit the two end points of the sweep to be set directly from the keyboard or by using the rotary control; the start frequency must be lower than the stop frequency (but see Sweep Type for selecting sweep direction).

Pressing the `centr/span` soft-key changes the screen to permit entry in terms of `centr` frequency and sweep `span` about that frequency; pressing the `start/stop` soft-key on that screen returns the display to the start and stop frequency form of entry.

Note that when the sweep is displayed in terms of center frequency and span the span will always be the exact difference between start and stop frequencies but the center frequency shown will be that of the frequency step nearest the true center frequency, see Principles of Sweep Operation section.

Sweep Time

Pressing the `time...` soft-key calls the `SWEEP TIME` screen.

```
SWEEP TIME:
  0.05 sec
(steps=100)
done ↕
```

The sweep time can be set from 0.03 to 999s with 3-digit resolution by direct keyboard entry or by using the rotary control. As explained in the Principles of Sweep Operation section, sweeps with a sweep time less than 1.03 seconds will contain less than the maximum 2048 steps because of the minimum 0.5ms dwell at each step. For this reason the number of actual steps in the sweep is shown (in brackets) as a non-editable field below the sweep time.

Sweep Type

Pressing the `type` soft-key calls the `SWEEP TYPE` screen.

```
SWEEP TYPE:
◆ continuous
◇ direction: up
◇ sync: on      done◇
```

This screen is used to set the sweep mode (continuous; triggered; triggered, hold and reset; manual) and sweep direction.

Alternate presses of the `direction` soft-key change the sweep direction from `up`, i.e. start frequency to stop frequency, to `down`, i.e. from stop frequency to start frequency. In the sweep mode descriptions which follow the direction is assumed to be `up`, i.e. start to stop; all modes can also be used with the direction set to `down`.

In `continuous` mode the generator sweeps continuously between the start and stop frequencies, triggered repetitively by an internal trigger generator whose frequency is determined by the sweep time setting. At the stop frequency the generator resets to the start frequency after a delay long enough for an oscilloscope to retrace, for example, and begins a new sweep. If `sync` is set to `on` (the default) the generator actually steps from the stop frequency to zero frequency and then starts the next sweep from the first point of the waveform, synchronized to the (internally generated) trigger signal.

This is useful because the sweep always starts from the same point in the waveform but the waveform discontinuity can be undesirable in some circumstances, e.g. filter evaluation. With `sync` set to `off`, the frequency steps directly and phase continuously from the stop frequency to the start frequency but is not synchronized to the software-generated trigger signal.

In `triggered` mode the generator holds the output at the start frequency until it recognizes a trigger. When triggered, the frequency sweeps to the stop frequency, resets, and awaits the next trigger. If `sync` is set to `on` the frequency resets to zero frequency (i.e. no waveform) and starts a new sweep at the first point of the waveform when the next trigger is recognized. If `sync` is set to `off` the waveform resets to the start frequency and runs at that frequency until the next trigger initiates a new sweep.

In `trig'd, hold/reset` mode the generator holds the output at the start frequency until it recognizes a trigger; when triggered, the frequency sweeps to the stop frequency and holds. At the next trigger the output is reset to the start frequency where it is held until the next sweep is initiated by a further trigger. If `sync` is set to `off` the output operates exactly as described above; if `sync` is set to `on` the frequency actual goes to zero at the start and begins each new sweep at the first point of the waveform.

For both `Triggered` and `Trig'd, hold, reset` modes the TRIG IN input is automatically set to external. The trigger source can be an external signal applied to TRIG IN (positive edge triggers), pressing the MAN/SYNC key on the front panel, or a remote command.

In `manual` mode the whole sweep process is controlled from the `MANUAL SWEEP` screen.

Manual Sweep

Pressing the `manual...` soft-key on the `SWEEP SETUP` screen calls the `MANUAL SWEEP FREQ` screen.

```
MANUAL SWEEP FREQ:
  1.630    MHz
◇ step fast    wrap◇
◆ step slow    done◇
```

Before manual control can be used, `manual` must be selected on the `SWEEP TYPE` screen, see above; if `manual` has not been set, the message `mode is not manual` will be displayed instead of the frequency.

In manual mode the frequency can be stepped through the sweep range, defined on the `SWEEP RANGE` screen, using the rotary control or cursor keys. Every point of the frequency table is stepped through if `step slow` is selected; if `step fast` is set then the frequency changes in multiple step increments. `step fast` cannot be set when the number of steps in the table is small.

If `wrap` is set the sweep wraps-round from `start` frequency to `stop` frequency and vice-versa; if `no wrap` is set the sweep finishes at either the `start` or `stop` frequency depending on the direction of the rotary control or cursor keys.

Sweep Spacing

Pressing the `spacing...` soft-key on the `SWEEP SETUP` screen calls the `SWEEP SPACING` screen.

```
SWEEP SPACING:
◆logarithmic
◇linear
done◇
```

With `linear` selected the sweep changes the frequency at a linear rate; with `logarithmic` selected the sweep spends an equal time in each frequency decade.

Sweep Marker

Pressing the `marker...` soft-key on the `SWEEP SETUP` screen calls the `SWEEP MARKER FREQ` screen.

```
SWEEP MARKER FREQ:
programm: 5.000 MHz
actual: 4.977 MHz
done◇
```

A new marker frequency can be programmed directly from the keyboard or by using the rotary control and cursor keys. Note that the marker frequency can only be one of the values in the sweep frequency table; any value in the sweep range can be entered but the actual value will be the nearest frequency in the table. When sweep is turned on, the actual marker frequency is shown in the non-editable field below the programmed frequency. For the default sweep setting of 100kHz to 10MHz in 50ms (400 steps), the actual frequency of a 5MHz marker is 4.977 MHz.

The marker duration is for the number of 0.5ms intervals that the frequency remains at the marker value; for fast and/or wide sweeps this will often be the 0.5ms minimum but for slow and/or narrow spans the marker may last many 0.5ms intervals. To avoid anomalous conditions the marker will not be exactly placed at the start and stop frequencies even though it can be programmed to be so. The marker polarity and level is set up on the `cursor/marker...` menu of the `UTILITY` screen, see System Operations section.

The marker frequency can be changed with sweep on but since the table of frequency values is rebuilt with each change this can be a slow process, especially if the rotary control is used. It is faster to switch sweep off, change the marker and switch sweep back on again.

Sweep Hold

The sweep can be held/restarted at any time at/from its current frequency by alternate presses of the `HOLD` key or remote command.

Triggered Burst and Gate

General

Triggered Burst and Gated modes are selected from the `MODE` screen, called by the `MODE` key, as alternatives to the default continuous mode.

```
MODE:
◆continuous
◊gated
◊triggered  setup...◊
```

In Triggered Burst mode a defined number of cycles are generated following each trigger event. This mode is edge triggered.

In gated mode the generator runs whenever the gating signal is true. This mode is level sensitive.

Both Triggered Burst and Gated modes can be controlled by either the internal trigger generator, an external trigger input, by the front panel `MAN/SYNC` key or by remote control.

Internal Trigger Generator

The period of the internal trigger generator is set with the `period` soft-key on the `TRIGGER INPUT SETUP` screen called by the `TRIG IN` key.

```
TRIGGER INPUT SETUP:
◊source: internal
◊slope: positive
◆period: 2.00ms
```

The internal trigger generator divides down a crystal oscillator to produce a 1:1 square-wave with a period from 0.02ms (50kHz) to 200s (0.05Hz). Generator period entries that cannot be exactly set are accepted and rounded up to the nearest available value, e.g. 0.109ms is rounded to 0.12ms.

When Triggered Burst or Gated modes are selected the `SYNC OUT` source automatically defaults to `trigger` which is the output of the internal trigger generator when internal triggering or gating is specified.

In Triggered Burst mode the selected edge of each cycle of the trigger generator is used to initiate a burst; the interval between bursts is therefore 0.02ms to 200s as set by the generator period.

In Gated mode the output of the main generator is gated on whilst the trigger generator output is true; the duration of the gate is therefore 0.01ms to 100s in step with trigger generator periods of 0.02ms to 200s.

External Trigger Input

External trigger or gate signals are applied to the front panel `TRIG IN` socket which has a TTL level (1.5V) threshold. In Triggered Burst mode the input is edge sensitive; the selected edge of each external trigger initiates the specified burst. In Gated mode the input is level sensitive; the output of the main generator is on whilst the gate signal is true.

The minimum pulse width that can be used with `TRIG IN` in Triggered Burst and Gated mode is 50ns and the maximum repetition rate is 1MHz. The maximum signal level that can be applied without damage is $\pm 10V$.

When Triggered Burst or Gated modes are selected the SYNC OUT source automatically defaults to `trigger` which is always a positive-edged version of the external trigger or gate signal when external triggering or gating is specified.

Triggered Burst

Triggered Burst mode is turned on with the `triggered` soft-key on the `MODE` screen. The `setup...` soft-key on this screen accesses the `TRIGGER SETUP` screen on which the burst count is set. The other trigger parameters are set on the `TRIGGER INPUT SETUP` screen called by pressing the `TRIG IN` key.

Trigger Source

The trigger source can be selected with the `source` soft-key on the `TRIGGER INPUT SETUP` screen to be `internal`, `external`, or `manual`.

With `internal` selected the internal trigger generator is used to initiate a burst; with `external` selected the specified edge of the signal at `TRIG IN` is used to initiate a burst. With either `internal` or `external` selected burst can also be initiated by pressing the `MAN/SYNC` key or by remote command; with `manual` selected as the source, only the `MAN/SYNC` key or remote command can be used to initiate a burst.

Trigger Edge

The `slope` soft-key is used to select the edge (`positive` or `negative`) of the external trigger signal that is used to initiate a burst. Note that the `trigger` signal from `SYNC OUT`, used for synchronizing the display of triggered burst on an oscilloscope for example, is always positive-going at the start of the burst.

Burst Count

The number of complete cycles in each burst following the trigger is set from the `TRIGGER SETUP` screen called by pressing `setup` on the `MODE` screen.

```
TRIGGER SETUP:
◊burst cnt: 0000001
◄clk: waveform sync
      done◊
```

The required count can be set by pressing the `burst cnt` soft-key followed by direct entries from the keyboard or by using the rotary control. The maximum number of clocks that can be counted is 1048575 ($20^{20}-1$).

The source of the burst count is selected by the `clk` soft-key on the `TRIGGER SETUP` screen. The default setting is `waveform sync` which is output once per cycle for all waveforms; with this setting, counting `waveform sync` is the same as counting waveform cycles so `burst cnt` sets the number of cycles. The first cycle starts, and the last cycle stops, at the first point in the waveform. Alternatively, for arbitrary waveforms, `clk` can be set to `pos'n marker` and the burst count will then be of position marker(s) set in the arbitrary waveform, see `edit waveform` menu on the `MODIFY` screen. The waveform starts at the first point and stops at the n^{th} marker where n is the burst count; at the next trigger the waveform playback starts at the n^{th} marker and stops at the $2n^{\text{th}}$ marker, and so on. The marker count wraps-round to the start of the waveform and counts through the markers again so that the waveform burst is every n markers, regardless of how many markers are in each waveform.

Gated Mode

Gated mode is turned on with the `gated` soft-key on the `MODE` screen. The parameters associated with Gated are set on the `TRIGGER INPUT SETUP` screen called by pressing the `TRIG IN` key.

```
TRIGGER INPUT SETUP:
◊source: internal
◊slope: positive
◆period: 2.00ms
```

Gate Source

The gate source can be selected with the `source` soft-key to be `internal`, `external` or `manual`.

With `internal` selected the internal trigger generator is used to gate the main waveform; the duration of the gate is half the generator period, see Internal Trigger Generator section.

With `external` selected the gate duration is from the point (nominally 1.5Volts) on the specified edge of the signal at `TRIG IN` until the same level on the opposite edge.

With either `internal` or `external` selected the gate can also be opened and closed by the `MAN/SYNC` key or remote command; with `manual` selected as the source, only `MAN/SYNC` or remote command can be used to open or close the gate. With `internal` or `external` selected the `MAN/SYNC` or remote command gate signal is exclusive-OR'd with the internal/external signal; with `manual` selected the gate is turned on and off with alternate key presses/remote commands.

Gate Polarity

If `slope` on the `TRIGGER INPUT SETUP` screen is set to `positive` the gate will open at the threshold on the rising edge and close on the threshold of the falling edge of an external gating signal, i.e. the gate signal is true when the `TRIG IN` signal is high. If the `slope` is set `negative` the gate signal is true when the `TRIG IN` signal is low.

Sync Out in Triggered Burst and Gated Mode

When Triggered Burst or Gated modes are selected the `SYNC OUT` source automatically defaults to `trigger`. `Trigger` is the output of the internal trigger generator when internal triggering or gating is specified and is a positive-edged version of the actual external signal when external triggering or gating is selected.

Alternatively, `SYNC OUT` can be set to `burst done` on the `SYNC OUT SETUP` screen. `SYNC OUT` then provides a signal which is low during the waveform burst and high at all other times.

Tone Mode

General

In Tone mode the generator output is stepped through a user-defined list of up to 16 frequencies under the control of a signal applied to the TRIG IN socket. A true level at TRIG IN will output the tone; a false level will stop the tone and switch the generator to the next frequency on the list ready for the next true level. A logic high level will be true if the `slope` is set to `positive` on the `TRIGGER INPUT SETUP` screen and a logic low level will be true if `slope` is set to `negative`.

All standard and arbitrary waveforms can be used in Tone mode with the exception of pulse, pulse-train and sequence. During Tone all waveforms are generated in DDS mode for fast phase-continuous switching between frequencies. For DDS operation all waveforms must be 4096 points in length; this is the natural length for standard waveforms but all arbitrary waveforms are expanded or condensed in software to 4096 points when the Tone list is built. This does not affect the original data.

Because DDS mode is used the frequency range for all waveforms is 1mHz to 10MHz in Tone mode, including triangle, ramp and squarewave which have different limits in continuous operation.

The minimum time per step is 20ms (tone time plus off time); the minimum tone time is 2ms and the minimum off time is 2ms.

Tone Setup

Press the `tone setup..` soft-key on the `MODE` screen, called by pressing the `MODE` key, to get the `TONE SETUP` screen:

```
TONE SETUP:   done◊
◊2.000000 kHz #2
◊3.000000 kHz del◊
◊end of list #4
```

Each frequency in the list can be changed by pressing the soft-key and entering the new value from the keyboard. The selected frequency can be deleted from the list by pressing the `del` (delete) soft-key. Additional frequencies can be added to the end of the list by selecting `end of list` with the appropriate soft-key and entering the new frequency from the keyboard.

The whole list can be scrolled back and forward through the display using the rotary control. When the list is complete, press the `done` softkey to return to the main `MODE` screen from which Tone mode can be turned on and off.

Connections for DTMF Testing. Sync Out and Trig In

The main use of Tone mode is DTMF (Dual Tone Multiple Frequency) testing in which 2 (or more) generators are set up with equal length lists of different frequencies and are triggered from a common signal. The outputs are summed together by connecting the output of one generator to the `VCA/SUM IN` of the other. DTMF testing generally uses sinewaves in the frequency range 600Hz to 1.6kHz.

The frequency lists are set up with one of each frequency pair in the corresponding position in the frequency list, see `Tone Setup` above. The lists must have the same number of frequencies. Tone mode is turned on by pressing the `tone` soft-key on the `MODE` screen, called by pressing the `MODE` key. When Tone is first turned on, and at any other time `tone` is pressed, the generators are set to the first frequency in the list (with the tone off) ready for the first trigger

signal; pressing the `tone` soft-keys on both generators is the way to re-synchronize the frequency lists should they have got out of step for any reason.

When tone mode is switched on the source for TRIG IN is automatically switched to `external` on the `TRIGGER INPUT SETUP` screen and cannot be changed. The `slope`, however, can be set to either `positive` or `negative`; `positive` means that a high level at TRIG IN will be treated as true and `negative` means that a low level will be true; the setting on both generators should be the same.

TRIG IN of both generators should be connected to the same external signal. When the trigger signal first goes true (as defined above) both generators will output the first frequency in their respective lists; when the trigger signal goes false the tones will stop; when the trigger goes true again the generators will output the next frequencies in their lists, and so on. It is important that no keys are pressed on either generator (or remote commands sent) that might cause the generators to lose the synchronization between the lists of frequencies; if this happens synchronization can be restored by pressing both `tone` soft-keys again to take both generators to the first frequency on the list.

SYNC OUT defaults to `trigger` and outputs a positive-edged version of the actual external trigger signal used.

The frequencies from the 2 generators are summed for DTMF by connecting the MAIN OUT of one generator to the VCA/SUM IN of the second. SUM mode is selected on the second generator on the `EXT VCA/SUM SETUP` screen, called by pressing the VCA/SUM IN key; see External SUM In section for details.

The above connections for TRIG IN and SYNC OUT also apply to 1, 3 or more generators used in Tone mode; frequencies from 3 or more generators can be summed by "daisy-chaining" the output from one generator into the VCA/SUM IN of the next.

Other Modulation Modes

External VCA

When used in VCA (Voltage Controlled Amplitude) mode the MAIN OUT amplitude is directly proportional to the external modulating signal voltage applied to the VCA/SUM IN socket. Suppressed carrier modulation (SCM) is achievable in this mode.

To use VCA mode set `VCA/SUM input:` to `VCA` on the `EXT VCA/SUM SETUP` screen which is called by pressing the `VCA/SUM IN` key:

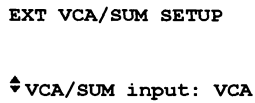

```
EXT VCA/SUM SETUP
VCA/SUM input: VCA
```

Connect the modulating signal to the VCA/SUM IN socket (nominally 6k Ω input impedance); a positive voltage increases the generator output and a negative voltage decreases the output. Note that clipping will occur if the combination of generator setting and VCA signal attempts to drive the input above 20Vpp open-circuit voltage.

External AM is achieved by setting the generator to the required output level and applying the modulation signal (which can be AC coupled if required) at the appropriate level to obtain the modulation depth required. If the generator output level is changed the amplitude of the modulating signal will have to be changed to maintain the same modulation depth.

The VCA signal is applied to the amplifier chain prior to the output attenuators. The amplifier itself is controlled over a limited range (~10dB) and the full amplitude range of the instrument is achieved by switching in up to five -10dB attenuation stages; a table of the approximate "ranges" for each attenuator setting is given at the end of this section. Peak modulation cannot exceed the maximum of the "range" within which the generator output is set.

Within each "range" the maximum output setting of the generator at which clipping is avoided is reduced from range maximum to half this value as modulation is increased from 0% to 100%; 100% modulation will be achieved at this mid-range setting with an external VCA signal of approximately 2.5Vpp. Modulation frequency range is DC to 100kHz.

The generator's amplitude control circuit has four quadrant operation, allowing the generator output to be inverted if the external VCA voltage is taken sufficiently negative. Suppressed carrier modulation (SCM) can be achieved by applying a modulating signal with a negative offset between 0V and -3V (depending on output level setting) sufficient to reduce the carrier output to zero.

It is also possible to modulate a DC level from the generator with a signal applied to VCA/SUM IN as follows. Set the generator to external trigger on the `TRIGGER INPUT SETUP` screen but do not apply a trigger signal to TRIG IN; select squarewave. The MAIN OUT is now set at the peak positive voltage defined by the amplitude setting; pressing the +/- key with `AMPLITUDE` displayed will set the level to the peak negative voltage. This DC level can now be modulated by the signal applied to VCA/SUM IN.

External SUM In

In SUM mode, set by setting `VCA/SUM input` to `SUM` on the `EXT/VCA/SUM SETUP` screen, an external signal applied to the VCA/SUM IN socket is summed with the selected waveform. This can be used to add "noise" to a waveform, for example, or to add two signals for DTMF (Dual Tone Multiple Frequency) testing.

The relationship between the SUM input and the summed output depends on the generator amplitude setting because the SUM input is applied to the amplifier chain prior to the output

attenuators. The amplifier is controlled over a limited range (~10dB) and the full amplitude range of the instrument is achieved by switching in up to five -10dB attenuation stages. For generator amplitudes in the range ~6.3Vpp to 20Vpp (20Vpp -10dB ≈6.3V) a corresponding signal range at SUM IN to force the generator output to 20Vpp would be ~5Vpp to 0V. If, however, the generator amplitude is in the range 630mV to 2.0Vpp (i.e. 20dB fixed attenuation switched in) the same signal range (~5Vpp to 0V) at SUM IN will only force the generator output to 2.0V; increasing the SUM IN signal beyond ~5Vpp will drive the amplifier into clipping without further increasing the amplitude. A table of the approximate amplitude ranges corresponding to each attenuator step is given at the end of this section. Within each range a SUM IN signal of ~5Vpp will force the output from range minimum to range maximum; if the amplitude is set to mid-range (e.g. 13V on the top range) the SUM IN signal needed to force the output to range maximum is about half, i.e. 2.5Vpp in this example.

A simple way to set the desired output levels for both waveforms being summed is as follows:

1. With no signal into SUM IN set the waveform, frequency and amplitude of the first signal e.g. 10Vpp, 1kHz, sinewave.
2. Select dc waveform on the generator and connect the other signal to SUM IN; the output waveform should change from dc to that applied to SUM IN. Adjust the level of the SUM IN signal to get the desired amplitude from the generator, e.g. 10Vpp.
3. Reselect sine. The output should be the sum of the two signals with an amplitude of, in this example, approximately 20Vpp.

Amplitude Range for Each Attenuator Step

Attenuation (dB)	Output range (hiZ)
0	6.3V - 20Vpp
10	2.0V - 6.3Vpp
20	0.63V - 2.0Vpp
30	200mV - 630mVpp
40	63mV - 200mVpp
50	20mV - 63mVpp

Arbitrary Waveform Generation

Introduction

Arbitrary (Arb) waveforms are generated by sequentially addressing the RAM containing the waveform data with the arbitrary clock. The frequency of the arb waveform is determined both by the arb clock and the total number of data points in the cycle.

In this instrument an arb waveform can have up to 65536 horizontal points. The vertical range is -2048 to +2047, corresponding to a maximum peak-peak output of 20 Volts. Up to 50 waveforms can be stored and each given a name; the number that can be stored depends on the number of points in each waveform.

Arb waveforms can be created using basic front panel editing capabilities (particularly useful for modifying existing standard or arb waveforms) or downloaded over the RS232 or GPIB interfaces using appropriate software e.g. WaveForm DSP2.

Arb Waveform Terms

The following terms are used in describing arb waveforms:

- *Horizontal Size.* The number of horizontal points is the time component of the waveform. The minimum size is 4 points and the maximum is 65536 points.
- *Waveform Address.* Each horizontal point on an arb waveform has a unique address. Addresses always start at 0000, thus the end address is always one less than the horizontal size.
- *Arb Frequency and Waveform Frequency.* The arb frequency is the clock rate of the data RAM address counters and has a range of 0.1Hz to 30MHz on this instrument. The waveform frequency depends on both the arb frequency and horizontal size. A 1000 point waveform clocked at an arb frequency of 30MHz has a waveform frequency of $30\text{e}6 \div 1000 = 30\text{kHz}$.
- *Data Value.* Each horizontal point in the waveform has an amplitude value in the range -2048 to +2047.
- *Arb Waveform Amplitude.* When playing arb waveforms the maximum output amplitude will depend on both the range of data values and the output amplitude setting. A waveform that contains data values ranging from -2048 to +2047 will produce a maximum output which is 100% of the programmed peak-to-peak amplitude; if the maximum range of the data values is only -1024 to +1023, for example, the maximum output will only be 50% of the programmed level.

Arb Waveform Creation

Creating arb waveforms with the instrument alone consists of two principle steps:

- Creating a new blank waveform, or a copy of an existing one, and giving it a size and a name
- Modifying that waveform using the various editing capabilities to get exactly the waveform required.

These steps are fully described in the Creating New Waveforms and Modifying Arbitrary Waveforms sections which follow.

Creating New Waveforms

Pressing the **CREATE** key calls the **CREATE NEW WAVEFORM** screen.

```
CREATE NEW WAVEFORM
free memory: 65536
◊create blank...
◊create from copy...
```

Create Blank Waveform

Pressing the **create blank...** soft-key calls the menu:

```
◆create: "wv01  "
◊size:  01024
◊cancel      create◊
```

The top line contains the user-defined waveform name which can be 8 characters long. The instrument allocates a default name of **wv(n)** starting at **wv1**; the name can be edited by selecting the appropriate character position with the cursor keys and then setting the character with the rotary control which scrolls through all alphanumeric characters in sequence.

Pressing the **size** soft-key permits the waveform length to be entered directly from the keyboard or by using the rotary control and cursor keys; the default size is 1024. The minimum size is 4 and the maximum 65536 (assuming no other arb waveforms have already been created); appropriate warnings are given if attempts are made to set a waveform size less than 4 or greater than the remaining available memory.

This menu can be exited either by pressing the **cancel** soft-key which keeps the name but does not allocate the memory space, or by pressing the **create** soft-key which builds a "blank" waveform and directly calls the **MODIFY** screen to permit waveform editing.

Create Waveform Copy

Pressing the **create from copy...** soft-key calls the following menu:

```
◆create: "wv01  "
◊from:  sine
◊size:  01024
◊cancel      create◊
```

The user-defined name and waveform size can be entered after pressing the **create:** and **size** soft-keys respectively, exactly as described in the previous section.

The source waveform which is to be copied can be selected by the **from** soft-key; repeated presses of the soft-key, cursor keys or using the rotary control will scroll through the list of all the available waveforms, including any other arbitrary waveforms already created.

The horizontal size of the waveform being copied does not have to be the same as the waveform being created. When the waveform is copied, by pressing the **create** key, the software compresses or expands the source waveform to create the copy. When the source is expanded the copy has additional interpolated points; when the source is compressed, significant waveform data may be lost, particularly from arb waveforms with narrow spikes if the compression ratio is large.

The menu can be exited by pressing the **cancel** soft-key, which keeps the name but does not implement the copy, or by pressing the **create** soft-key, which makes the copy and directly calls the **MODIFY** screen to permit waveform editing.

Modifying Arbitrary Waveforms

Pressing the **MODIFY** front panel key, or the **create** soft-key on either of the **CREATE NEW WAVEFORM** menus calls the **MODIFY** screen.

```
⏏ MODIFY:   wv01
◊ resize...  rename...◊
◊ delete...  limits...◊
◊ edit waveform..
```

This screen gives access to a number of menus which permit the selected waveform to be resized, renamed, edited, etc. The arb waveform to be modified is selected using the rotary control or cursor keys to step through all possible choices; the current choice is displayed on the top line beside **MODIFY** :

Waveform Edit Cursor

During any arbitrary waveform modify procedure which involves setting waveform addresses, waveform cursor(s) are output from the rear panel **CURSOR/MARKER OUT** socket. The amplitude, polarity and width of the cursor is set on the **cursor/marker...** menu of the **UTILITY** screen, see **System Operations** section. The cursors are positioned at the **start** and **stop** addresses used for the various edit operations described below (one address/cursor only for point edit). The cursor signal can be displayed on a second channel of the 'scope or used to modulate the Z-axis to bright-up the stop and start addresses.

Note that the addresses are retained when moving between edit functions. Thus if the stop and start addresses are set for waveform insert, the same addresses appear as the defaults when wave amplitude edit is selected, for example; the addresses can of course subsequently be changed.

Resize Waveform

Pressing the **resize...** soft-key on the **MODIFY** screen calls the **Resize** screen.

```
Resize:      wv01
(old size: 01024)
new size: 01024
◊cancel      resize◊
```

Resize changes the number of points in the waveform; the new size can be larger or smaller than the old size. When the new size is larger, the software adds additional interpolated points. When the size is smaller, points are removed. Reducing the waveform size may cause the waveform to lose significant data. There is no "undo" for resize.

Resize is implemented by pressing the **resize** soft-key or aborted by pressing the **cancel** soft-key; both return the display to the **MODIFY** screen.

Rename Waveform

Pressing the **rename...** soft-key on the **MODIFY** screen calls the **Rename** screen:

```
Rename:      wv01
as "y"
◊cancel      rename◊
```

The new name can be entered below the original by selecting the appropriate character position with the cursor keys and then setting the character with the rotary control which scrolls through all the alphanumeric characters in sequence. The name can be up to 8 characters long.

Return to the **MODIFY** screen by pressing **rename** (which implements the new name) or **cancel**.

Delete Waveform

Pressing the **delete...** soft-key displays a request for confirmation that the selected waveform is to be deleted.

```
Delete waveform
"vw01  "
?
◊cancel      delete◊
```

Confirm deletion by pressing the **delete** soft-key which will return the display to the **MODIFY** screen with the next arb waveform automatically selected; **cancel** aborts the deletion.

Waveforms currently being displayed cannot be deleted. Deleted waveforms cannot be recovered.

Waveform Limits

Pressing the **limits** soft-key calls the **Limits** screen:

```
Limits of: vw01
◆start adrs: 00000
◊stop adrs: 01023
(size: 01024) done◊
```

This menu is used to define the limits of a section of an arb waveform. The section of the waveform defined in this way will be the only part output when that arb is selected.

Set the lower and upper limits with the **start adrs** and **stop adrs** soft-keys respectively; there must be at least 4 points including the start and stop. The default limits are the first and last points of the waveform. Confirm by pressing the **done** soft-key which returns the display to the **MODIFY** screen.

These limits will be used until new limits are defined. The whole waveform still exists; the limits simply define the section of the waveform which is currently active.

Edit Waveform

Pressing the **edit waveform...** soft-key calls the **EDIT FUNCTIONS** menu:

```
EDIT FUNCTIONS:
◊point edit...
◊line draw...
◊wave insert...
```

From this menu can be selected functions which permit the waveform to be edited point-by-point (point edit), by drawing lines between two points (line draw) or by inserting all or part of an existing waveform into the waveform being edited (wave insert). In addition, sections of the waveform can be selected and their peak-to-peak level changed using **wave amplitude**, or baseline changed using **wave offset**. Sections of the waveform can be copied into itself (block copy) and position markers for use at Sync Out can also be defined.

Pressing the **exit** soft-key on any of these edit screens will return the display to the **EDIT FUNCTIONS** menu.

Point Edit

Press the `point edit...` soft-key to call the `POINT EDIT` screen:

```
POINT EDIT
(addr, value)
◆ (00512, +0500) ◇
◇exit next point◇
```

To modify a point, press the `addr` soft-key and enter the address directly from the keyboard or by using the rotary control; the current data value will be displayed to the right of the address. To change the value press `value` and enter the new value directly from keyboard or by using the rotary control. Changing the data value automatically updates the waveform.

Pressing the `next point` soft-key automatically advances the address by one point; alternatively press `addr` to re-select address and permit entries from the keyboard or by rotary control.

Line Edit

Press the `line draw...` soft-key to call the `LINE` screen:

```
LINE (addr, value)
◆frm (00512, +0500)◇
◇to (00750, +0412)◇
◇exit draw line◇
```

The display shows a `frm` (from) and `to` address which will be the points between which a straight line will be created when the `draw line` soft-key is pressed. The default `frm` address is the first point on the waveform or the point most recently edited if point edit has been used. Set the "from" address and value by pressing the appropriate soft-key and making an entry direct from the keyboard or by using the rotary control; repeat for the "to" address and value.

The line will be drawn between the two selected points when the `draw line` soft-key is pressed.

Wave Insert

Pressing `wave insert...` calls the wave insert screen:

```
◆wv01 → wv02
◇ 0000 strt 00400 ◇
◇ 00512 stop 01000 ◇
◇exit insert◇
```

Wave Insert places waveform data from `wv01` (standard or arbitrary waveform, but not pulse, or pulse-train) into `wv02`.

A section of an arbitrary waveform can be inserted, as defined by the left-hand `strt` (start) and `stop` addresses, e.g. 00000 and 00512 of `wv01` on the screen above. These addresses will default to the limits set on the `limits` menu of the `MODIFY` screen, but can be reset to any section of the whole waveform. Change the addresses by pressing the appropriate soft-key and making entries from the keyboard or by rotary control. The destination of the selected section of the source waveform in the new waveform is defined by the right-hand `strt` (start) and `stop` addresses. Change the addresses by pressing the appropriate soft-key and making entries from the keyboard or by rotary control.

The insert is actioned by pressing the `insert` soft-key. If there is a size difference between the two sections of waveform then the software will expand or compress the source to fit the new waveform. Compressing the waveform may lose some significant data.

To insert sections of the current waveform within itself see Block Copy.

Block Copy

Pressing `block copy...` calls the `BLOCK COPY` screen:

```
BLOCK COPY: execute ◊
◊start: 00400  exit ◊
◊stop:  01000  undo ◊
◊dest:  00000  save ◊
```

Block copy allows a section of the current waveform to be inserted within itself. The block to be inserted is defined by the `start` and `stop` addresses. Change the addresses by pressing the appropriate soft-key and making entries from the keyboard or by rotary control.

The destination address for the start of the section is set by pressing the `dest` soft-key and entering the address. The effect of making the block copy can then be previewed by pressing the `execute` soft-key.

Note that if there are not enough waveform points between the destination address and end of waveform to accommodate the copied section, the waveform being copied will simply be truncated. The copy can be removed by pressing the `undo` soft-key or by entering a new destination address.

When the block copy is as required it can be saved by pressing the `save` soft-key; once saved the original waveform cannot be recovered.

Waveform Amplitude

Pressing the `wave amplitude` soft-key calls the `AMPLITUDE` screen:

```
AMPLITUDE:  001.00◊
◊start: 00400
◊stop:  01000  undo◊
◊exit          save◊
```

The waveform amplitude can be changed on a section of the waveform defined by the `start` and `stop` addresses. Set the addresses by pressing the appropriate soft-key and making entries directly from the keyboard or by rotary control.

The data values over the specified section of the waveform can be multiplied by a factor of between 0.01 and 100.0 by making entries in the `AMPLITUDE` field. Press the appropriate soft-key and make entries direct from the keyboard or by using the rotary control; the amplitude changes on completion of the entry. Note that entries >1.0 will cause clipping if the waveform already uses the full -2048 to +2047 data value range; the result is, however, still treated as a valid waveform.

The original waveform can be restored by pressing the `undo` soft-key. When the amplitude has been modified as required the new waveform can be saved by pressing the `save` soft-key; pressing `exit` returns to the `EDIT FUNCTIONS` screen without change.

Waveform Offset

Pressing the `wave offset` soft-key calls the `WAVE OFFSET` screen.

```
WAVE OFFSET: +0000◆
◇start: 00400
◇stop: 01000  undo ◇
◇exit          save ◇
```

The waveform offset can be changed on a section of the waveform defined by the `start` and `stop` addresses. Set the addresses by pressing the appropriate soft-key and making entries directly from the keyboard or by rotary control.

The data values over the specified section of the waveform are offset by the value entered in the `WAVE OFFSET` field. Press the appropriate soft-key and make entries direct from the keyboard or by using rotary control. Entries in the range -4096 to +4095 will be accepted; this permits, in the extreme, waveform sections with values at the -2048 limit to be offset to the opposite limit of +2047. Warnings are given when the offset causes clipping but the entry is still accepted.

The original waveform can be restored by pressing the `undo` soft-key. When the offset has been modified as required the new waveform can be saved by pressing the `save` soft-key; pressing `exit` returns to the `EDIT FUNCTIONS` screen without change.

Wave Invert

Pressing the `wave invert` soft-key calls the `INVERT` screen:

```
INVERT:      wv02
◆start adrs: 00512
◇stop adrs:  00750
◇exit        invert ◇
```

The waveform can be inverted on a section of the waveform defined by the `start` and `stop` addresses. Set the addresses by pressing the appropriate soft-key and making entries directly from the keyboard or by rotary control.

The data values over the specified section of the waveform are inverted about 0000 each time the `invert` soft-key is pressed.

Press `exit` to return to the `EDIT FUNCTIONS` screen.

Position Markers

Pressing the `position markers...` soft-key calls the `POSITION MARKER EDIT` screen:

```
POSITION MARKER EDIT
◆adrs: 00000  <0> ◇
◇patterns...
◇exit        clear all ◇
```

Position markers are output from SYNC OUT when the source (`src`) is set to `pos'n marker` on the `SYNC OUTPUT SETUP` screen.

Position markers can be set at any or all of the addresses of a waveform either individually, using the `adrs` (address) soft-key, or as a pattern, using the `patterns...` menu.

A marker can be set directly at an address by pressing the `adrs` soft-key followed by a keyboard entry; pressing the right-hand soft-key on the `adrs` line then toggles the marker setting between `<1>` and `<0>` as shown in the arrowed brackets. The address can be changed

by incrementing with the `adrs` key, by using the rotary control, or by further keyboard entries; marker settings are changed at each new address with the right-hand soft-key. Markers show immediately they are changed.

Alternatively, markers can be input as patterns by using the `patterns...` sub-menu.

```
PATTERN: 00000000◆  
◊start: 00000  
◊stop: 01023  
◊exit: do pattern◊
```

The start and stop addresses of the markers within the waveform are set using the `start` and `stop` soft-keys respectively followed by a direct keyboard entry or by rotary control. The pattern itself is set in the top line of the display; press the soft-key to the right of `PATTERN:` and enter the sequence of 1s and 0s using 1 and 0 from the keyboard (which auto-increments to the next character) or with the rotary control (using the cursor keys to move the edit cursor along the pattern). The pattern consists of 16 values; if the cursor keys are used to skip over some character positions these will automatically be filled with the value of the last one specified to the left. The pattern is entered repeatedly across the whole range defined by the start and stop addresses when the `do pattern` soft-key is pressed; pressing `exit` returns to `POSITION MARKER EDIT` screen without implementing the pattern.

Pressing the `clear all` soft-key displays a request for confirmation that all markers should be cleared from the waveform. Pressing `clear` cancels all the markers and returns the display to `POSITION MARKER EDIT`; pressing `cancel` aborts the clear.

Arbitrary Waveform Sequence

Up to 4 arbitrary waveforms may be linked in a sequence. Each waveform can have a loop count of up to 32768 and the whole sequence can run continuously or be looped up to 1048575 times using the Triggered Burst mode.

Pressing the `SEQUENCE` key calls the initial `SEQUENCE` screen:

```
SEQUENCE  
◊sequence setup..  
  
◊stop run◆
```

A previously defined sequence can be run and stopped from this screen using the `run` and `stop` soft-keys; sequence can also be switched on from the `STANDARD WAVEFORMS` screen with the `sequence` soft-key.

Sequence Set-up

Pressing the `sequence setup...` soft-key on the `SEQUENCE` screen (or the `setup...` soft-key next to `sequence` on the `STANDARD WAVEFORMS` screen) calls the sequence set up screen:

```
◊seg: 2 off◊  
◆wfm wv03 limit◊  
◊step on: count  
◊cnt: 00001 done◊
```

Repeated presses of the `seg` soft-key steps the display through the set-ups of each of the 4 segments of the sequence. With the exception of segment 1 which is always on (and therefore has no on-off soft-key) the 4 segment set-ups are identical in format.

The segment to be set-up is selected with the `seg` soft-key; the 4 segments can be selected in sequence with repeated presses of the soft-key or by using the rotary control.

Once the segment to be edited has been set the waveform for that segment is selected with the `wfm` (waveform) soft-key; the list of all arbitrary waveforms already created is stepped through with repeated presses of the `wfm` soft-key or by using the rotary control. The part of the waveform that will be used is defined by the limits setting (default setting is the whole waveform) as described in the Waveform Limits paragraph of the Modifying Arbitrary Waveforms section. For convenience the `Limits` screen can be directly accessed from sequence set-up by pressing the `Limit` soft-key; pressing `done` after setting limits will return the display to the sequence set-up screen.

The criteria for stepping between waveform segments is set by the `step on` soft-key. The default setting is `step on: count` which means that the waveform will step on to the next segment after the number of waveform cycles specified in the `cnt` (count) field; up to 32768 cycles can be set with `cnt` selected, using direct keyboard entries or by rotary control.

Alternatively, the step on criteria can be set to `trig edge` or `trig level` in the `step on` field; trigger edge or trigger level can be mixed with count (i.e. some segments can step on count, others on the specified trigger condition) but trigger edge cannot be mixed with trigger level in the same sequence.

If `trig edge` is selected the sequence starts running at the first waveform segment when sequence is set to `run` and steps to the following segments in turn at each subsequent trigger. The trigger source can be any of the settings selected on the `TRIGGER INPUT SETUP` screen (called by the TRIG IN key); these are described fully in the Triggered Burst and Gate section. At each trigger the current waveform cycle plus one further whole cycle are completed before the waveform of the next segment is started.

If `trig level` is selected the sequence runs continuously through each segment in turn (1 cycle per segment) while the trigger level is true. When the trigger level goes false the waveform currently selected runs continuously until the level goes true again at which point the sequence runs continuously through each segment in turn again. The trigger level source can be any of the settings selected on the `TRIGGER INPUT SETUP` screen with the exception of the `MAN/SYNC` key which can only produce an edge, not a level, when pressed.

Providing the `step on:` field is set to `count` for all segments the waveform sequence can also be run in Gated and Triggered Burst modes in the same way as simple waveforms; refer to the Triggered Burst and Gated section for full details.

Note that in Triggered Burst mode the clock source should be set to `waveform sync` on the `TRIGGER SETUP` screen and will actually count `sequence sync` when sequence mode is running. The burst counter therefore counts complete sequences (up to 1048575); this is in addition to the counts of up to 32768 cycles in each waveform segment.

The individual segments of the sequence can be turned on or off with the `on-off` soft-key. Note that turning a segment off will automatically set all subsequent segments off; turning a segment on will turn on that segment and any others between segment 1 and itself that were previously off. Segment 1 is always on.

When the whole sequence is defined the set-up is constructed by pressing the `done` soft-key which returns the display to the initial `SEQUENCE` screen. The sequence can be run and stopped from this screen with the `run` and `stop` soft-keys respectively.

Frequency and Amplitude Control with Arbitrary Waveforms

Frequency and Amplitude control work in essentially the same way as for standard waveforms with the following minor differences.

Frequency

Pressing the FREQUENCY key with an arbitrary waveform selected calls the **ARBITRARY FREQUENCY** screen:

```
ARBITRARY FREQUENCY
  30.00   MHz
◆sample  waveform◊
◆freq    period◊
```

Frequency can be set in terms of frequency or period as before by pressing the **freq** or **period** soft-key respectively. Note that the frequency and period resolution in arbitrary mode is only 4 digits because Clock Synthesis generation is used, see Principles of Operation section.

Additionally, for arbitrary waveforms, frequency/period can be set in terms of the sample clock frequency, by pressing the **sample** soft-key, or in terms of the waveform frequency, by pressing the **waveform** soft-key. The relationship between them is

$$\text{waveform frequency} = \text{sample frequency} \div \text{waveform size.}$$

Frequency/period entries are made direct from the keyboard or by using the rotary control in the usual way.

Pressing the FREQUENCY key with Sequence selected calls the **SEQ CLOCK FREQUENCY** screen:

```
SEQ CLOCK FREQUENCY
  30.00   MHz
◆freq    period◊
```

Frequency/period can now **only** be set in terms of the clock frequency. Frequency/period entries are made direct from the keyboard or by using the rotary control in the usual way.

Amplitude

Pressing the AMPLitude key with an arbitrary waveform selected calls the **AMPLITUDE** screen.

```
AMPLITUDE:
  +20.0 Vpp
◆Vpp
                load:hiZ◊
```

This differs from the **AMPLITUDE** screen for standard waveforms in that amplitude can now only be entered in volts peak-to-peak.

Note that the peak-to-peak amplitude set will only actually be output if the arbitrary waveform has addresses with values which reach -2048 and +2047; if the maximum value range is -1024 to +1023 for example then the maximum peak-to-peak voltage will only be 10Vpp for the instrument set to 20Vpp.

Sync Out Settings with Arbitrary Waveforms

The default setting for Sync Out when arbitrary waveforms are selected is **waveform sync**; this is a pulse that starts coincident with the first point of the waveform and is a few points wide.

If a waveform sequence has been selected then Sync Out defaults to **sequence sync**; this is a waveform which goes low during the last cycle of the last waveform in a sequence and is high at all other times. When sequence is used in Triggered Burst mode, the default and only source **clk** for **burst count** on the **TRIGGER SETUP** screen becomes **sequence sync** regardless of whether the display shows **waveform sync** or **pos'n marker**.

Sync Out can additionally be set to `pos'n marker` for arbitrary waveforms. If Triggered Burst mode is used the source `clk` can also be set to count `pos'n markers`. Position markers can be used in blocks to create a pulse waveform whose phase can be varied (by varying the point in the position marker pattern where markers go from off to on) with respect to the arbitrary waveform from the main output, for example.

Waveform Hold in Arbitrary Mode

There are a number of ways in which arb waveforms can be held and restarted.

Pressing the front panel HOLD key stops the waveform at the current level; pressing HOLD a second time restarts the waveform from that level.

A logic low or switch closure at the rear panel HOLD IN socket also stops the waveform at the current level; a logic high or switch opening restarts the waveform from that level.

If, while the waveform is held by either of the above means, the MAN/SYNC key is pressed or a logic high is applied to TRIG IN (regardless of the TRIG IN setup) then the waveform is reset to its first point; the waveform will restart from this point when HOLD is pressed again or a high is applied to the rear panel HOLD IN socket.

Output Filter Setting

The output filter type is automatically chosen by the software to give the best signal quality for the selected waveform. The choice can, however, be overridden by the user and this is most probably a requirement with arbitrary waveforms.

To change the filter, press the FILTER key to call the `FILTER SETUP` screen.

```
FILTER SETUP
mode: auto
type: 10MHz elliptic
```

The default `mode` is `auto` which means that the software selects the most appropriate filter. With the setting on `auto` the `type` can be changed manually but the choice will revert to the automatic selection as soon as any relevant parameter is changed. To override the automatic choice press the `mode` soft-key to select `manual`.

The three filter choices, which are either automatically selected or set manually with the `type` soft-key, are as follows:

- *10MHz elliptic:* The automatic choice for sine, cosine, haversine, havercos, $\sin x/x$ and triangle. Would be the better choice for arb waveforms with an essentially sinusoidal content.
- *10MHz Bessel:* The automatic choice for positive and negative ramps, arb and sequence.
- *No filter:* The automatic choice for squarewave, pulse and pulse-trains. May be the better choice for arb waveforms with an essentially rectangular content.

Pulse and Pulse-trains

Pulse and pulse-trains are both selected and set-up from independent menus on the **STANDARD WAVEFORMS** screen called by pressing the STD key. Pulse and pulse-trains have similar timing set-ups and considerations but pulses are only unipolar, with a maximum amplitude of 10Vpp, whereas pulse-trains can be bipolar, with a maximum peak-to-peak of 20Vpp.

Pulse Set-up

Pulse waveforms are turned on with the **pulse** soft-key on the **STANDARD WAVEFORMS** screen; pressing the **setup...** softkey beside **pulse** calls the first of the pulse set-up screens:

```
Enter pulse period:
      100.0 us
◊exit          next◊
```

The pulse period can be set between 133.3ns and 100s, with 4-digit resolution, by direct entries from the keyboard or by using the rotary control. Pressing the **next** soft-key calls the pulse width screen:

```
Enter pulse width:
program 50.00 us
(actual 50.00 us)
◊exit          next◊
```

The width can be entered directly from the keyboard or by using the rotary control. Any value in the range 33.33ns to 99.99s can be programmed but the **actual** value may differ because of the considerations discussed below; for this reason the **actual** pulse width is shown (in brackets) below the **program** width.

Pressing the **next** soft-key calls the pulse delay screen:

```
Enter pulse delay:
program +0.000 ns
(actual +0.000 ns)
◊exit          done◊
```

This is very similar to the pulse width screen and, again, the **actual** delay is shown below the **program** delay. The delay value that can be entered must be in the range \pm (pulse period - 1 point); positive values delay the pulse output with respect to waveform sync from SYNC OUT; negative values cause the pulse to be output before the waveform sync. Pressing the **done** soft-key on this screen returns the display to the **STANDARD WAVEFORMS** screen.

The means by which pulse period is set-up in the hardware requires an understanding because it affects the setting resolution of both pulse width and delay. Pulse is actually a particular form of arbitrary waveform made up of between 4 and 50,000 points; each point has a minimum time of 33.33ns corresponding to the fastest clock frequency of 30MHz.

At short pulse periods, i.e. only a few points in the waveform, the setting resolution is, however, much better than 33.33ns because the time-per-point is adjusted as well as the number of points; since the pulse width and delay are also defined in terms of the same point time, varying the time-per-point affects their resolution. For example, if the period is set to 500ns, the minimum pulse width, when set to 33.33ns, will actually be 33.33ns; 15 points at 33.33ns each exactly define the 500ns period. However, if the period is set to 499.9ns, 15 points at the minimum point time of 33.33ns will be too long so 14 points are used and the point time is

adjusted to 35.71ns (499.9÷14); 35.71ns is now the increment size used when changing the pulse width and delay.

For periods above 1.67ms the maximum number of points in the waveform (50,000) becomes the factor determining pulse width and delay resolution. For example, with the period set to 100ms, the smallest pulse width and delay increment is 2µs (100ms÷50,000). This may appear to cause significant "errors" at extreme settings (e.g. setting 100ns in the above example will still give an actual width of 2µs) but in practical terms a 1 in 50,000 resolution (0.002%) is quite acceptable.

Pulse period can be adjusted irrespective of the pulse width and delay setting (e.g. can be set smaller than the programmed pulse width) because, unlike a conventional pulse generator, pulse width and delay are adjusted **proportionally** as the period is changed. For example, if, from the default pulse settings of 100µs period/50µs width, the period is changed to 60µs the pulse width **actual** changes to 30µs even though the **program** width is still 50µs; to get a 50µs width with the period at 60µs the width must be re-entered as 50µs after the period has been changed.

Period can also be changed from the **PULSE PERIOD** screen called by pressing the **FREQ** key with Pulse mode selected.

```
PULSE PERIOD
  100.0    us
◊freq      period◊
```

The new setting can be entered either as a period in the way already described or as a frequency by first pressing the **freq** soft-key. However, changing the period/frequency from this screen is slightly different from changing period on the **pulse setup** screen. When changing from this screen the number of points in the waveform is never changed (just as with a true arb) which means that the shortest period/highest frequency that can be set is number of waveform points x33.33ns. To achieve faster frequencies (up to the specification limit) the period must be changed from the pulse set-up screen; changing the frequency from this screen causes the number of points to be reduced as the period is reduced (for periods <1.67ms).

Pulse-train Setup

Pulse-trains are turned on with the **pulse-train** softkey on the **STANDARD WAVEFORMS** screen; pressing the **setup...** soft-key beside **pulse-train** calls the first of the setup screens:

```
Enter no of pulses
in train (1-10):
      2
◊done      next◊
```

The number of screens used for the setup depends on the number of pulses in the pulse-train. The first three screens define the parameters that apply to the whole pattern (number of pulses, overall pulse-train period and baseline voltage); subsequent screens define the pulse level, width and delay for each pulse in turn (3 screens for pulse 1, then 3 screens for pulse 2, etc.). Pressing **next** on any screen calls the next setup screen, finally returning the display to the **STANDARD WAVEFORMS** screen from which pulse-train can be turned on and off; pressing **done** returns the display directly to the **STANDARD WAVEFORMS** screen from any setup screen. The pulse-train is built only after **next** is pressed after the last parameter setup or whenever **done** is pressed, assuming a change has been made. The first screen, shown above, sets the number of pulses (1-10) in the pattern; enter the number of pulses directly from the keyboard or by using the rotary control.

Pressing **next** calls the pulse train period screen:

```
Enter pulse train
period:
 100.0us
◊done      next◊
```

The period can be set, with 4-digit resolution, from 133.3ns to 100s by direct keyboard entries or by using the rotary control.

Pressing **next** calls the baseline voltage screen, the last of the general setup screens:

```
Enter the baseline
voltage:
 +0.000 V
◊done      next◊
```

The baseline is the signal level between the end of one pulse and the start of the next, i.e. it is the level all pulses start and finish at. The baseline can be set between -5.0V and +5.0V by direct keyboard entries or by using the rotary control. Note that the **actual** baseline level at the output will only be as set in this field if the output amplitude is set to maximum (10Vpp into 50Ω) on the **AMPLITUDE** screen and terminated in 50Ω. If the amplitude was set to 5Vpp into 50Ω then the actual baseline range would be -2.5V to +2.5V for set values of -5.0 to +5.0V, i.e. the amplitude control "scales" the baseline setting. The actual output levels are doubled when the output is unterminated.

Pressing **next** on this screen calls the first of 3 screens for the first pulse in the pattern:

```
◊Pulse 1 level
◆ +5.000 V
◊done      next◊
```

The pulse level can be set on this screen between -5.0V and +5.0V by direct keyboard entries or by using the rotary control. As with the baseline level described above the set pulse levels are only output if the amplitude setting is set to maximum (10Vpp into 50Ω) on the **AMPLITUDE** screen and terminated in 50Ω. Adjusting the amplitude "scales" both the peak pulse levels and baseline together, thus keeping the pulse shape in proportion as the amplitude is changed, exactly as for arb waveforms. Actual output levels are doubled when the output is unterminated.

Note that by pressing the **Pulse** softkey on this (and subsequent screens) the pulse to be edited can be directly set from the keyboard or by using the rotary control; this is useful in directly accessing a particular pulse in a long pulse train instead of having to step through the whole sequence.

Pressing **next** calls the pulse width screen for the first pulse:

```
◊Pulse 1 width
◆program 25.00 us
(actual 25.00 us)
◊done      next◊
```

The width can be entered directly from the keyboard or by using the rotary control. Any value in the range 33.33ns to 99.99s can be programmed but the **actual** value may differ; for this reason the **actual** pulse width is shown (in brackets) below the **program** width. The variation between **program** and **actual** will only really be noticeable for very short pulse-train periods (only a few points in the pulse-train) and very long periods (each of the 50,000 points has a long

dwel time) for exactly the same reasons as described in the Pulse Setup section; refer to that section for a detailed explanation.

Pressing **next** calls the pulse delay screen for the first pulse:

```
◊Pulse 1 delay
◆program +0.000 ns
  (actual +0.000 ns)
◊done           next◊
```

The pulse delay is entered in the same way as pulse width and, again, the **actual** delay is shown below the **program** delay for the same reasons. The delay value that can be entered must be in the range \pm (pulse-train period -1 point); positive values delay the pulse with respect to waveform sync from SYNC OUT; negative values cause the pulse to be output before the waveform sync.

Pressing **next** on this screen calls the first of the 3 screens for setting the parameters of Pulse 2, and so on through all the pulses in the pulse-train. In this way all parameters of all pulses are set. The pulse-train is built when **next** is pressed on the last screen of the last pulse or if **done** is pressed on any screen.

Care must be taken that the set widths and delays of the individual pulses are compatible with each other and the overall pulse-train period, i.e. delays must not be such that pulses overlap each other and delays + widths must not exceed the pulse-train period; unpredictable results will occur if these rules are not followed.

Once the pulse-train has been defined the period can be adjusted irrespective of the pulse width and delay settings for the individual pulses because, unlike a conventional pulse generator, the individual pulse widths and delays are adjusted **proportionally** to the period as the period is changed.

Period can also be changed from the **PULSE-TRN PERIOD** screen called by pressing the **FREQ** key with pulse-train mode selected:

```
PULSE-TRN PERIOD
  100.0    us
◊freq      period◆
```

The new setting can be entered either as a period in the way already described or as a frequency by first pressing the **freq** soft-key. However, changing the period/frequency from this screen is slightly different from changing period on the **pulse-train setup** screen. When changing from this screen the number of points in the waveform is never changed (just as with a true arb) which means that the shortest period/highest frequency that can be set is the number of waveform points x 33.33ns. To achieve faster frequencies (up to the specification limit) the period must be changed from the pulse setup screen; changing the frequency from this screen causes the number of points to be reduced as the period is reduced (for period <1.67ms).

Waveform Hold in Pulse and Pulse-Train Modes

A logic low or switch closure at the rear panel HOLD IN socket stops the waveform at the current level; a logic high or switch opening restarts the waveform from that level.

If, while the waveform is held, a logic high is applied to TRIG IN (regardless of the TRIG IN setup) then the waveform is reset to its first point; the waveform will restart from this point when a high is applied to the rear panel HOLD IN socket.

Synchronizing Generators

Two or more generators can be synchronized together following the procedure outlined below; the number of generators that can be linked in this way will depend on the clocking arrangement, cable lengths, etc., but problems should not be experienced with up to 4 generators.

Synchronizing Principles

Frequency locking is achieved by using the clock output from the 'master' generator to drive the clock inputs of 'slaves'. The additional connection of an initializing SYNC signal permits each slave to be synchronized such that the phase relationship between master and slave outputs is that specified on each slave generator's **SLAVE PHASE ANGLE** menu.

Synchronization is only clearly visible between generators when the ratio of slave to master frequencies is a small integer or fraction, e.g. 2kHz:1kHz, 3kHz:2kHz. It will be practically impossible at say 17kHz:3kHz. Special considerations arise with waveforms generated by Clock Synthesis mode (squarewave, arbitrary, pulse, pulse-train and sequence) because of the relatively poor precision with which the frequency is actually derived in the hardware. With these waveforms, frequencies with an apparently rational relationship (e.g. 3:1) may be individually synthesized such that the ratio is not close enough to e.g. 3:1 to maintain phase lock over a period of time; the only relationships guaranteed to be realized precisely are $2^n:1$ because the division stages in Clock Synthesis mode are binary. A further complication arises with arb waveforms because waveform frequency depends on both waveform size and clock frequency (waveform frequency = clock frequency \div waveform size). The important relationship with arbs is the ratio of clock frequencies and the above considerations on precision apply to them. The most practical use of synchronization will be to provide outputs at the same frequency, or maybe harmonics, but with phase differences.

Connections for Synchronization

The preferred clock connection arrangement is for the rear panel REF CLOCK IN/OUT of the master (which will be set to **phase lock master**) to be connected directly to each of the REF CLOCK IN/OUT sockets of the slaves (which will be set to **phase lock slave**). The alternative arrangement is to 'daisy-chain' the slaves from the master using a BNC T-piece at each slave connection but reflections can cause clock corruption at the intermediate taps under some circumstances.

Similarly the preferred synchronizing connection is from the SYNC OUT of the master, which defaults to **phase lock**, directly to each of the TRIG IN inputs of the slaves. The alternative arrangement is to 'daisy-chain' from each SYNC OUT to the next generator's TRIG IN in turn; this does not give rise to any data integrity problems but cumulative hardware delays will worsen the phase-shift accuracy. If daisy-chaining between SYNC OUTs is used then the SYNC OUT on the slaves (which would otherwise default to **waveform sync**) must be manually set to **phase lock** on the SYNC OUTPUT SETUP screen.

Generator Set-ups

Each generator can have its main parameters set to any value, with the exception that the ratio of frequencies between master and slave must be rational and each generator can be set to any waveform, but see Synchronizing Principles section.

The master has its CLOCK IN/OUT set to **phase lock master** on the **REF. CLOCK I/O SETUP** menu called by the **ref. clock i/o** soft-key on the UTILITY screen, see System Operations section.

```
REF. CLOCK I/O SETUP
◊input
◊output      phase...◊
◄phase lock slave
```

Repeated presses of the `phase lock` soft-key toggle between `master` and `slave`.

The slaves are set to `slave` and the phase relationships between the slaves and the master are set individually on the `SLAVE PHASE ANGLE` screens of each slave, accessed by pressing the `phase...` soft-key on the `REF. CLOCK I/O SETUP` above.

```
SLAVE PHASE ANGLE:
  progrm: +000°
(actual: +000°)
             done◊
```

The phase angle is entered directly from the keyboard, or by using the rotary control, in the range -360° to $+360^\circ$. With all DDS waveforms (which comprise 4096 points) the actual phase angle will be the same as the programmed angle. However, with arb waveforms, etc. which have less than 360 points per cycle the `actual` phase may differ from the `progrm` phase because of insufficient resolution and is therefore displayed below the programmed value.

When the phase is set, pressing the `done` soft-key returns the display to the `REF CLOCK I/O SETUP` screen. The convention adopted in Synchronized mode is that a negative phase setting **delays** the slave output with respect to the master; for example, a phase setting of -90° will delay the slave by a quarter-cycle with respect to the master. If the slave's TRIG IN inputs are all driven directly from the master then all phase shift is referenced from the master; thus 4 generators set to the same frequency with the 3 slaves set to -90° , -180° and -270° respectively will give four evenly spaced phases of the same signal. If, however, the synchronizing signal was daisy-chained from each SYNC OUT to the next generator's TRIG IN then the phase shifts become cumulative and each slave must be set to -90° phase to achieve the same result.

Hardware delays become increasingly significant as frequency increases causing additional phase delay between the master and slaves. However, these delays can be largely nulled-out by 'backing-off' the phase settings of the slaves.

Synchronizing

Having made the connections and set up the generators as described in the preceding paragraphs, synchronization is achieved by pressing the `MAN/SYNC` key of each slave in turn. Once synchronized any change to the setup may require resynchronization.

System Operations from the Utility Menu

Pressing the UTILITY key calls a list of menus which give access to various system operations including storing/recalling setups from non-volatile memory, error messages, power on settings and calibration.

Storing and Recalling Setups

Complete waveform setups can be stored to or recalled from non-volatile RAM using the menus called by the `store` and `recall` soft-keys.

Pressing `store...` calls the store screen:

```
Save to store No: 1
◊execute
```

Nine stores, numbered 1 to 9 inclusive, are available. Select the store using the rotary control or direct keyboard entry and press `execute` to implement the store function.

Pressing `recall...` (or the RECALL front panel key) calls the recall screen:

```
Recall store No: 1
◊set defaults
◊execute
```

In addition to the user-defined stores, the factory defaults can be reloaded by pressing the `set defaults` soft-key. Note that loading the defaults does not change any arbitrary waveforms, the setups stored in memories 1 to 9, or the RS232/GPIB interface settings.

Warnings and Error messages

The default setup is for all warning and error messages to be displayed and for a beep to sound with each message. This setup can be changed on the `error` menu:

```
◊error beep: ON
◊error message: ON
◄warn beep: ON
◊warn message: ON
```

Each feature can be turned ON or OFF with alternate presses of the appropriate soft-key.

The last two error messages can be viewed by pressing the `last error...` soft-key. Each message has a number and the full list appears in Appendix 1. See also Warnings and Error Messages in the Standard Waveform Operation section.

Reference Clock In/Out Setting

The function of the rear panel REF CLOCK IN/OUT socket is set on the `ref. clock i/o` menu.

```
REF. CLOCK I/O SETUP
◆input
◊output
◊phase lock
```

The default setting is for the socket to be set to `input`, i.e. an input for an external 10MHz reference clock. When set to `input` the system is automatically switched over to the external reference when an adequate signal level (TTL/CMOS threshold) is detected at REF CLOCK IN/OUT but will continue to run from the internal clock in the absence of such a signal.

With the clock set to `output` a buffered version of the internal 10MHz clock is made available at the socket.

With `phase lock` selected the socket can be set to be a `master` or `slave` when used for synchronizing (phase-locking) multiple generators. See Synchronizing Generators section for full details.

Remote Interface Setup

Pressing `remote...` calls the `REMOTE SETUP` screen which permits RS232/GPIB choice and selection of address and Baud rate. Full details are given in the Remote Operation section.

Cursor/Marker Output

Pressing the `cursor/marker...` soft-key calls the `CURSOR/MARKER OUTPUT` screen.

```
CURSOR/MARKER OUTPUT
^amplitude: 2V
^polarity: negative
^cursor width: 1
```

The cursor/marker signal is output from the rear panel `CURSOR/MARKER OUT` socket. It is used as a marker in sweep mode or as a cursor in arbitrary waveform mode. It can be used to modulate the Z-axis of an oscilloscope or be displayed on a second scope channel.

With `amplitude` selected the cursor/marker level can be set between 2 and 14V in 2V steps. With `polarity` selected the polarity can be set `positive` or `negative`. With `polarity` set to `positive` the cursor/marker is a positive-going pulse from the 0V baseline; with `polarity` set to `negative` the cursor/marker is a negative-going pulse from the 2 - 14V set amplitude level, i.e. `negative` gives an inverted signal.

When used as a sweep marker (i.e. Sweep mode selected) the width is determined by the time spent at the marker frequency, see Sweep Marker in the Sweep Operation section for details.

When used as a cursor during arbitrary waveform editing (i.e. `edit waveform` selected on the `MODIFY` screen) the width can be adjusted by repeated presses of the `cursor width` soft-key or by using the rotary control. The width is adjustable so that the cursor can still be made visible even with long arbitrary waveforms. The width is always an odd number of waveform points increasing in steps of 2 points from 1 to 3, 5, 7, etc. A `width` setting of 1 corresponds to 1 waveform point, `width 2` is 3 points, `width 3` is 5 points and so on up to `width 30` which is 59 points.

Power On Setting

Pressing the `power on...` soft-key calls the `POWER ON SETTING` screen:

```
POWER ON SETTING
^default values
^restore last setup
^recall store no. 1
```

The setting loaded can be selected with the appropriate soft-key to be **default values** (the default setting), **restore last setup** (i.e. the settings at power down are restored at power up) or any of the settings stored in non-volatile memories 1 to 9. **Default values** restores the factory default settings, see Appendix 3.

System Information

The **system info..** soft-key calls the **SYSTEM INFO** screen which shows the instrument name and software revision. When **system info..** is pressed a checksum is also made of the firmware EPROM and the result displayed; this can be used when a software fault is suspected to check that the EPROM has not got corrupted.

Calibration

Pressing **calibration** calls the calibration routine, see Calibration section.

Calibration

All parameters can be calibrated without opening the case, i.e. the generator offers 'closed-box' calibration. All adjustments are made digitally with calibration constants stored in EEPROM. The calibration routine requires only a DVM and a frequency counter and takes no more than a few minutes.

The crystal in the timebase is pre-aged but a further aging of up to ± 5 ppm can occur in the first year. Since the aging rate decreases exponentially with time it is an advantage to recalibrate after the first 6 month's use. Apart from this it is unlikely that any other parameters will need adjustment.

Calibration should be carried out only after the generator has been operating for at least an hour in normal ambient conditions.

Equipment Required

- 3½ digit DVM with 0.25% DC accuracy and 0.5% AC accuracy at 1kHz.
- Frequency counter capable of measuring 10.00000MHz.

The DVM is connected to the MAIN OUT and the counter to the SYNC OUT.

Frequency meter accuracy will determine the accuracy of the generator's clock setting and should ideally be ± 1 ppm.

Calibration Procedure

The calibration procedure is accessed by pressing the **calibration...** soft-key on the **UTILITY** screen.

```
CALIBRATION SELECTED
Are you sure ?
◊password... tests...◊
◊exit      continue◊
```

The software provides for a 4-digit password in the range 0000 to 9999 to be used to access the calibration procedure. If the password is left at the factory default of 0000 no messages are shown and calibration can proceed as described in the Calibration Routine section; only if a non-zero password has been set will the user be prompted to enter the password.

Setting the Password

On opening the Calibration screen press the **password...** soft-key to show the password screen:

```
ENTER NEW PASSWORD
-----
```

Enter a 4-digit password from the keyboard; the display will show the message NEW PASSWORD STORED! for two seconds and then revert to the **UTILITY** menu. If any keys other than 0-9 are pressed while entering the password the message ILLEGAL PASSWORD! will be shown.

Using the Password to Access Calibration or Change the Password

With the password set, pressing **calibration...** on the **UTILITY** screen will now show:

```
ENTER PASSWORD
-----
```

When the correct password has been entered from the keyboard the display changes to the opening screen of the calibration routine and calibration can proceed as described in the Calibration Routine section. If an incorrect password is entered the message INCORRECT PASSWORD! is shown for two seconds before the display reverts to the **UTILITY** menu.

With the opening screen of the calibration routine displayed after correctly entering the password, the password can be changed by pressing the **password...** soft-key and following the procedure described in Setting the Password. If the password is set to 0000 again, password protection is removed.

The password is held in EEPROM and will not be lost when the memory battery back-up is lost. In the event of the password being forgotten, contact the manufacturer for help in resetting the instrument.

Calibration Routine

The calibration procedure proper is entered by pressing **continue** on the opening Calibration screen; pressing **exit** returns the display to the **UTILITY** menu. Pressing **tests...** calls a menu of basic hardware checks used at production test; these are largely self-explanatory but details can be found in the Service Manual if required. At each step the display changes to prompt the user to adjust the rotary control or cursor keys, until the reading on the specified instrument is at the value given. The cursor keys provide coarse adjustment, and the rotary control fine adjustment. Pressing **next** increments the procedure to the next step; pressing **CE** decrements back to the previous step. Alternatively, pressing **exit** returns the display to the last CAL screen at which the user can choose to either **save new values**, **recall old values** or **calibrate again**.

The first two displays (CAL 00 and CAL 01) specify the connections and adjustment method. The subsequent displays, CAL 02 to CAL 19, permit all adjustable parameters to be calibrated.

The full procedure is as follows:

CAL 02	Multiplier zero offset	Adjust for minimum.
CAL 03	Offset #1	Adjust for $0V \pm 5mV$.
CAL 04	Offset #2	Adjust for $0V \pm 5mV$.
CAL 05	Offset #3	Adjust for $0V \pm 5mV$.
CAL 06	Offset #4	Adjust for $0V \pm 5mV$.
CAL 07	DC offset at + full scale.	Adjust for $+10V \pm 10mV$.
CAL 08	DC offset at - full scale.	Check for $-10V \pm 10mV$.
CAL 09	SUM offset at 0dB.	Adjust for $0V \pm 5mV$.
CAL 10	SUM offset at 10dB	Adjust for $0V \pm 5mV$.
CAL 11	SUM full-scale at 0dB	Adjust for $10V \pm 10mV$.
CAL 12	SUM full-scale at 10dB	Adjust for $10V + 10mV$.
CAL 13	Waveform offset #1	Adjust for $0V \pm 5mV$.
CAL 14	Output level at full-scale	Adjust for $10V \pm 10mV$.
CAL 15	Waveform offset #2	Adjust for $0V \pm 5mV$.
CAL 16	20dB attenuator	Adjust for $1V \pm 1mV$.
CAL 17	40dB attenuator	Adjust for $0.1V \pm .1mV$.
CAL 18	10dB attenuator	Adjust for $2.236V AC \pm 10mV$.
CAL 19	Clock calibrate	Adjust for $10.00000 MHz$ at SYNC OUT.

Remote Calibration

Calibration of the instrument may be performed over the RS232 or GPIB interface. To completely automate the process the multimeter and frequency meter will also need to be remote controlled and the controller will need to run a calibration program unique to this instrument.

The remote calibration commands allow a simplified version of manual calibration to be performed by issuing commands from the controller. The controller must send the CALADJ command repeatedly and read the dmm or frequency meter until the required result for the selected calibration step is achieved. The CALSTEP command is then issued to accept the new value and move to the next step.

While in remote calibration mode very little error checking is performed and it is the controllers responsibility to ensure that everything progresses in an orderly way. Only the following commands should be used during calibration.

WARNING: Using any other commands while in calibration mode may give unpredictable results and could cause the instrument to lock up, requiring the power to be cycled to regain control.

CALIBRATION <cpd> [,nrf] The calibration control command. <cpd> can be one of three sub-commands:-

START Enter calibration mode; this command must be issued before any other calibration commands will be recognised.

SAVE Finish calibration, save the new values and exit calibration mode.

ABORT Finish calibration, do not save the new values and exit calibration mode.

<nrf> represents the calibration password. The password is only required with CALIBRATION START and then only if a non-zero password has been set from the instrument's keyboard. The password will be ignored, and will give no errors, at all other times.

It is not possible to set or change the password using remote commands.

CALADJ <nrf> Adjust the selected calibration value by <nrf>. The value must be in the range -100 to +100. Once an adjustment has been completed and the new value is as required the CALSTEP command must be issued for the new value to be accepted.

CALSTEP Step to the next calibration point.

For general information on remote operation and remote command formats, refer to the following sections.

Remote Operation

The following sections detail the operation of the instrument via both GPIB and RS232. Where operation is identical no distinction is made between the two. Where differences occur these are detailed in the appropriate sections or in some cases separate sections for GPIB and RS232. It is therefore only necessary to read the general sections and those sections specific to the interface of interest.

Address and Baud Rate Selection

For successful operation each instrument connected to the GPIB or addressable RS232 must be assigned a unique address and, in the case of addressable RS232, all must be set to the same baud rate.

The instrument's remote address for operation on both the RS232 and GPIB interfaces is set via the **remote** menu on the UTILITY screen, see System Operations section.

```
REMOTE SETUP
↕ interface: RS232
()address: 05
()baud rate: 9600
```

With **interface** selected with the **interface** soft-key, the selection can be toggled between RS232 and GPIB with alternate presses of the soft-key, the cursor keys or by using the rotary control.

With **address** selected, the soft-key, cursor keys or rotary control can be used to set the address.

With **baud rate** selected, the soft-key, cursor keys or rotary control can be used to set the baud rate for the RS232 interface.

When operating on the GPIB all device operations are performed through a single primary address; no secondary addressing is used.

NOTE: GPIB address 31 is not allowed by the IEEE 488 standards but it is possible to select it as an RS232 address.

Remote/Local Operation

At power-on the instrument will be in the local state with the REMOTE lamp off. In this state all keyboard operations are possible. When the instrument is addressed to listen and a command is received the remote state will be entered and the REMOTE lamp will be turned on. In this state the keyboard is locked out and remote commands only will be processed. The instrument may be returned to the local state by pressing the LOCAL key; however, the effect of this action will remain only until the instrument is addressed again or receives another character from the interface, when the remote state will once again be entered.

RS232 Interface

RS232 Interface Connections

The 9-way D-type serial interface connector is located on the instrument rear panel. The pin connections are as shown below:

Pin	Name	Description
1	-	No internal Connection
2	TXD	Transmitted data from instrument
3	RXD	Received data to instrument

4	-	No internal connection
5	GND	Signal ground
6	-	No internal connection
7	RXD2	Secondary received data (see diagram)
8	TXD2	Secondary transmitted data (see diagram)
9	GND	Signal ground

Pins 2, 3 and 5 may be used as a conventional RS232 interface with XON/XOFF handshaking. Pins 7, 8 and 9 are additionally used when the instrument is connected for addressable RS232 operation, see below.

Using a simple cable assembly, a 'daisy chain' connection system between any number of instruments, up to the maximum of 32 can be made, as shown below:

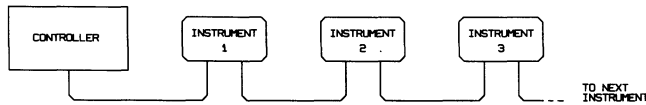

The daisy chain consists of the transmit data (TXD), receive data (RXD) and signal ground lines only. There are no control/handshake lines. This makes XON/XOFF protocol essential and allows the inter-connection between instruments to contain just 3 wires. The wiring of the adapter cable is shown below:

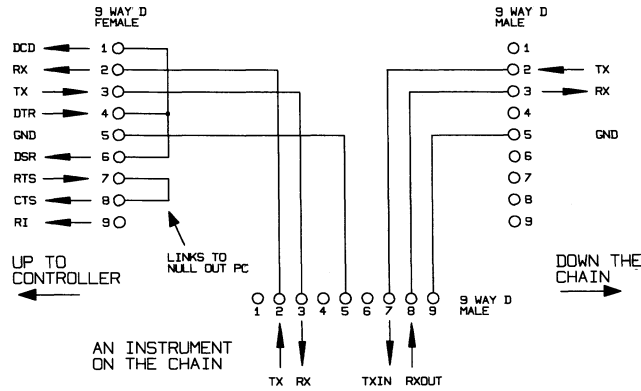

All instruments on the interface must be set to the same baud rate and all must be powered on, otherwise instruments further down the daisy chain will not receive any data or commands.

The other parameters are fixed as follows:

Start bits	1
Data bits	8
Parity	None
Stop bits	1

RS232 Character Set

Because of the need for XON/XOFF handshake it is possible to send ASCII coded data only; binary blocks are not allowed. Bit 7 of ASCII codes is ignored, i.e. assumed to be low. No distinction is made between upper and lower case characters in command mnemonics and they may be freely mixed. The ASCII codes below 20H (space) are reserved for interface control.

RS232 Interface Control Codes

All instruments intended for use on the addressable RS232 bus use the following set of interface control codes. Codes between 00H and 1FH which are not listed here as having a particular meaning are reserved for future use and will be ignored. Mixing interface control codes inside instrument commands is not allowed except as stated below for CR and LF codes and XON and XOFF codes.

When an instrument is first powered on it will automatically enter the Non-Addressable mode. In this mode the instrument is not addressable and will not respond to any address commands. This allows the instrument to function as a normal RS232 controllable device. This mode may be locked by sending the Lock Non-Addressable mode control code 04H (LNA). The controller and instrument can now freely use all 8 bit codes and binary blocks but all interface control codes are ignored. To return to addressable mode the instrument must be powered off.

To enable addressable mode after a instrument has been powered on the Set Addressable Mode control code, 02H (SAM), must be sent. This will then enable all instruments connected to the addressable RS232 bus to respond to all interface control codes. To return to Non-Addressable mode the Lock Non-Addressable mode control code must be sent which will disable addressable mode until the instruments are powered off.

Before an instrument is sent a command it must be addressed to listen by sending the Listen Address control code, 12H (LAD), followed by a single character which has the lower 5 bits corresponding to the unique address of the required instrument, e.g. the codes A-Z or a-z give the addresses 1-26 inclusive while @ is address 0 and so on. Once addressed to listen the instrument will read and act upon any commands sent until the listen mode is canceled.

Because of the asynchronous nature of the interface it is necessary for the controller to be informed that an instrument has accepted the listen address sequence and is ready to receive commands. The controller will therefore wait for code 06H (ACK) before sending any commands. The addressed instrument will provide this ACK. The controller should time-out and try again if no ACK is received within 5 seconds.

Listen mode will be canceled by any of the following interface control codes being received:

12H	LAD	Listen Address followed by an address not belonging to this instrument.
14H	TAD	Talk Address for any instrument.
03H	UNA	Universal Unaddress control code.
04H	LNA	Lock Non-Addressable mode control code.
18H	UDC	Universal Device Clear.

Before a response can be read from an instrument it must be addressed to talk by sending the Talk Address control code, 14H (TAD) followed by a single character which has the lower 5 bits

corresponding to the unique address of the required instrument, as for the listen address control code above. Once addressed to talk the instrument will send the response message it has available, if any, and then exit the talk addressed state. Only one response message will be sent each time the instrument is addressed to talk.

Talk mode will be canceled by any of the following interface control codes being received:

12H	LAD	Listen Address for any instrument.
14H	TAD	Talk Address followed by an address not belonging to this instrument.
03H	UNA	Universal Unaddress control code.
04H	LNA	Lock Non-Addressable mode control code.
18H	UDC	Universal Device Clear.

Talk mode will also be canceled when the instrument has completed sending a response message or has nothing to say.

The interface code 0AH (LF) is the Universal Command and response Terminator (UCT); it must be the last code sent in all commands and will be the last code sent in all responses.

The interface code 0DH (CR) may be used as required to aid the formatting of commands; it will be ignored by all instruments. Most instruments will terminate responses with CR followed by LF.

The interface code 13H (XOFF) may be sent at any time by a listener (instrument or controller) to suspend the output of a talker. The listener must send 11H (XON) before the talker will resume sending. This is the only form of handshake control supported by RS232.

RS232 Interface Control Code List

02H	SAM	Set Addressable mode.
03H	UNA	Universal Unaddress control code.
04H	LNA	Lock Non-Addressable mode control code.
06H	ACK	Acknowledge that listen address received.
0AH	UCT	Universal Command and response Terminator.
0DH	CR	Formatting code, otherwise ignored.
11H	XON	Restart transmission.
12H	LAD	Listen Address - must be followed by an address belonging to the required instrument.
13H	XOFF	Stop transmission.
14H	TAD	Talk Address - must be followed by an address belonging to the required instrument.
18H	UDC	Universal Device Clear.

GPIB Interface

The 24-way GPIB connector is located on the instrument rear panel.

The pin connections are as specified in IEEE Std. 488.1-1987 and the instrument complies with IEEE Std. 488.1-1987 and IEEE Std. 488.2-1987.

GPIB Subsets

This instrument contains the following IEEE 488.1 subsets:

Source Handshake	SH1
Acceptor Handshake	AH1
Talker	T6
Listener	L4
Service Request	SR1
Remote Local	RL1
Parallel Poll	PP1
Device Clear	DC1
Device Trigger	DT1
Controller	C0
Electrical Interface	E2

GPIB IEEE Std. 488.2 Error Handling

The IEEE 488.2 UNTERMINATED error (addressed to talk with nothing to say) is handled as follows. If the instrument is addressed to talk and the response formatter is inactive and the input queue is empty then the UNTERMINATED error is generated. This will cause the Query Error bit to be set in the Standard Event Status Register, a value of 3 to be placed in the Query Error Register and the parser to be reset. See the STATUS REPORTING CAPABILITIES section for further information.

The IEEE 488.2 INTERRUPTED error is handled as follows. If the response formatter is waiting to send a response message and a <PROGRAM MESSAGE TERMINATOR> has been read by the parser or the input queue contains more than one END message then the instrument has been INTERRUPTED and an error is generated. This will cause the Query Error bit to be set in the Standard Event Status Register, a value of 1 to be placed in the Query Error Register and the response formatter to be reset thus clearing the output queue. The parser will then start parsing the next <PROGRAM MESSAGE UNIT> from the input queue. See the STATUS REPORTING CAPABILITIES section for further information.

The IEEE 488.2 DEADLOCK error is handled as follows. If the response formatter is waiting to send a response message and the input queue becomes full then the instrument enters the DEADLOCK state and an error is generated. This will cause the Query Error bit to be set in the Standard Event Status Register, a value of 2 to be placed in the Query Error Register and the response formatter to be reset thus clearing the output queue. The parser will then start parsing the next <PROGRAM MESSAGE UNIT> from the input queue. See the STATUS REPORTING CAPABILITIES section for further information.

GPIB Parallel Poll

Complete parallel poll capabilities are offered on this generator. The Parallel Poll Enable Register is set to specify which bits in the Status Byte Register are to be used to form the *ist* local message. The Parallel Poll Enable Register is set by the *PRE <nrf> command and read by the *PRE? command. The value in the Parallel Poll Enable Register is ANDed with the Status Byte Register; if the result is zero then the value of *ist* is 0 otherwise the value of *ist* is 1.

The instrument must also be configured so that the value of *ist* can be returned to the controller during a parallel poll operation. The instrument is configured by the controller sending a Parallel Poll Configure command (PPC) followed by a Parallel Poll Enable command (PPE). The bits in the PPE command are shown below:

bit 7 =	X	don't care
bit 6 =	1	Parallel poll enable
bit 5 =	1	
bit 4 =	0	
bit 3 =	Sense	sense of the response bit; 0 = low, 1 = high
bit 2 =	?	bit position of the response
bit 1 =	?	
bit 0 =	?	

Example. To return the RQS bit (bit 6 of the Status Byte Register) as a 1 when true and a 0 when false in bit position 1 in response to a parallel poll operation send the following commands

*PRE 64<pmt>, then PPC followed by 69H (PPE)

The parallel poll response from the generator will then be 00H if RQS is 0 and 01H if RQS is 1.

During parallel poll response the DIO interface lines are resistively terminated (passive termination). This allows multiple devices to share the same response bit position in either wired-AND or wired-OR configuration, see IEEE 488.1 for more information.

Power on Settings

The following instrument status values are set at power on:

	Status Byte Register	= 0
*	Service Request Enable Register	= 0
	Standard Event Status Register	= 128 (pon bit set)
*	Standard Event Status Enable Register	= 0
	Execution Error Register	= 0
	Query Error Register	= 0
*	Parallel Poll Enable Register	= 0

*Registers marked thus are specific to the GPIB section of the instrument and are of limited use in the addressable RS232 environment.

The instrument will be in local state with the keyboard active.

The instrument parameters at power on are determined on the POWER ON SETTING menu. If **restore last setup** or **recall store no. nn** has been set and a defined state is required by the controller at start up then the command *RST should be used to load the system defaults.

If for any reason an error is detected at power up in the non-volatile ram a warning will be issued and all settings will be returned to their default states as for a *RST command.

Status Reporting

This section describes the complete status model of the instrument. Note that some registers are specific to the GPIB section of the instrument and are of limited use in an addressable RS232 environment.

Standard Event Status and Standard Event Status Enable Registers

These two registers are implemented as required by the IEEE std. 488.2.

Any bits set in the Standard Event Status Register which correspond to bits set in the Standard Event Status Enable Register will cause the ESB bit to be set in the Status Byte Register.

The Standard Event Status Register is read and cleared by the *ESR? command. The Standard Event Status Enable register is set by the *ESE <nrf> command and read by the *ESE? command.

- Bit 7 - Power On. Set when power is first applied to the instrument.
- Bit 6 - Not used.
- Bit 5 - Command Error. Set when a syntax type error is detected in a command from the bus. The parser is reset and parsing continues at the next byte in the input stream.
- Bit 4 - Execution Error. Set when an error is encountered while attempting to execute a completely parsed command. The appropriate error number will be reported in the Execution Error Register.
- Bit 3 - Not used.
- Bit 2 - Query Error. Set when a query error occurs. The appropriate error number will be reported in the Query Error Register as listed below.
 - 1 Interrupted error
 - 2 Deadlock error
 - 3 Unterminated error
- Bit 1 - Not used.
- Bit 0 - Operation Complete. Set in response to the *OPC command.

Status Byte Register and Service Request Enable Register

These two registers are implemented as required by the IEEE std. 488.2.

Any bits set in the Status Byte Register which correspond to bits set in the Service Request Enable Register will cause the RQS/MSS bit to be set in the Status Byte Register, thus generating a Service Request on the bus.

The Status Byte Register is read either by the *STB? command, which will return MSS in bit 6, or by a Serial Poll which will return RQS in bit 6. The Service Request Enable register is set by the *SRE <nrf> command and read by the *SRE? command.

- Bit 7 - Not used.
- Bit 6 - RQS/MSS. This bit, as defined by IEEE Std. 488.2, contains both the Requesting Service message and the Master Status Summary message. RQS is returned in response to a Serial Poll and MSS is returned in response to the *STB? command.
- Bit 5 - ESB. The Event Status Bit. This bit is set if any bits set in the Standard Event Status Register correspond to bits set in the Standard Event Status Enable Register.
- Bit 4 - MAV. The Message Available Bit. This will be set when the instrument has a response message formatted and ready to send to the controller. The bit will be cleared after the Response Message Terminator has been sent.
- Bit 3 - Not used.
- Bit 2 - Not used.
- Bit 1 - Not used.
- Bit 0 - Not used.

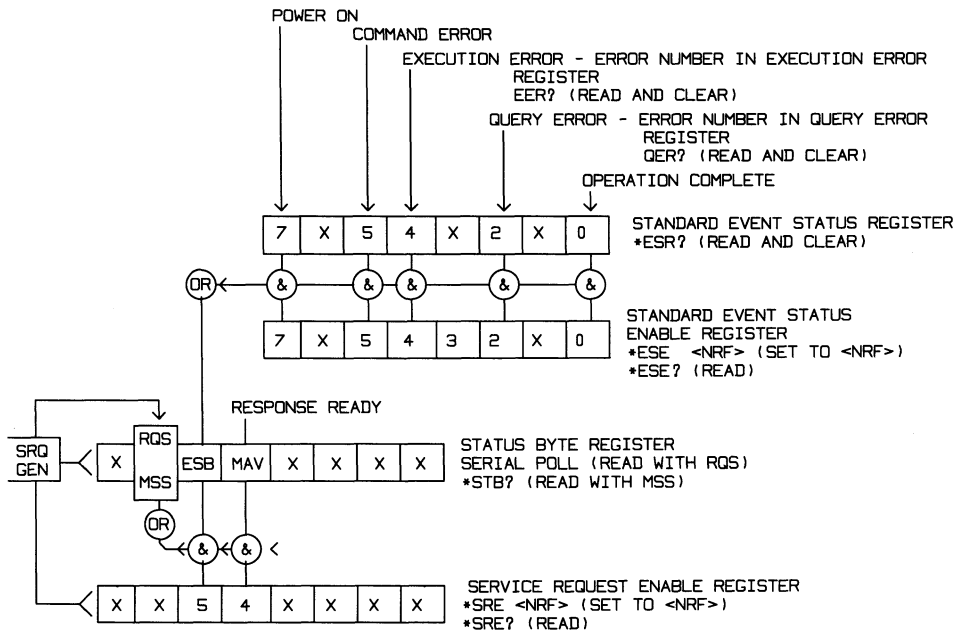

Status Model

RS232 Remote Command Formats

Serial input to the instrument is buffered in a 256 byte input queue which is filled, under interrupt, in a manner transparent to all other instrument operations. The instrument will send XOFF when approximately 200 characters are in the queue. XON will be sent when approximately 100 free spaces become available in the queue after XOFF was sent. This queue contains raw (un-parsed) data which is taken, by the parser, as required. Commands (and queries) are executed in order and the parser will not start a new command until any previous command or query is complete. There is no output queue which means that the response formatter will wait, indefinitely if necessary, until the instrument is addressed to talk and the complete response message has been sent, before the parser is allowed to start the next command in the input queue.

Commands are sent as <PROGRAM MESSAGES> by the controller, each message consists of zero or more <PROGRAM MESSAGE UNIT> elements separated by <PROGRAM MESSAGE UNIT SEPARATOR> elements.

<PROGRAM MESSAGES> are separated by <PROGRAM MESSAGE TERMINATOR> elements which consist of the new line character (0AH).

A <PROGRAM MESSAGE UNIT SEPARATOR> is the semi-colon character ';' (3BH).

A <PROGRAM MESSAGE UNIT> is any of the commands in the REMOTE COMMANDS section.

Responses from the instrument to the controller are sent as <RESPONSE MESSAGES>. A <RESPONSE MESSAGE> consists of one <RESPONSE MESSAGE UNIT> followed by a <RESPONSE MESSAGE TERMINATOR>.

A <RESPONSE MESSAGE TERMINATOR> is the carriage return character followed by the new line character (0DH 0AH).

Each query produces a specific <RESPONSE MESSAGE> which is listed along with the command in the REMOTE COMMANDS section.

<WHITE SPACE> is ignored except in command identifiers. e.g. `*C LS' is not equivalent to `*CLS'. <WHITE SPACE> is defined as character codes 00H to 20H inclusive with the exception of the codes specified as addressable RS232 interface commands.

The high bit of all characters is ignored.

The commands are case insensitive.

GPIB Remote Command Formats

GPIB input to the instrument is buffered in a 256 byte input queue which is filled, under interrupt, in a manner transparent to all other instrument operations. The queue contains raw (un-parsed) data which is taken, by the parser, as required. Commands (and queries) are executed in order and the parser will not start a new command until any previous command or query is complete. There is no output queue which means that the response formatter will wait, indefinitely if necessary, until the instrument is addressed to talk and the complete response message has been sent, before the parser is allowed to start the next command in the input queue.

Commands are sent as <PROGRAM MESSAGES> by the controller, each message consists of zero or more <PROGRAM MESSAGE UNIT> elements separated by <PROGRAM MESSAGE UNIT SEPARATOR> elements.

<PROGRAM MESSAGES> are separated by <PROGRAM MESSAGE TERMINATOR> elements which may be any of the following:

NL	The new line character (0AH)
NL^END	The new line character with the END message
^END	The END message with the last character of the message

A <PROGRAM MESSAGE UNIT SEPARATOR> is the semi-colon character ';' (3BH).

A <PROGRAM MESSAGE UNIT> is any of the commands in the REMOTE COMMANDS section.

Responses from the instrument to the controller are sent as <RESPONSE MESSAGES>. A <RESPONSE MESSAGE> consists of one <RESPONSE MESSAGE UNIT> followed by a <RESPONSE MESSAGE TERMINATOR>.

A <RESPONSE MESSAGE TERMINATOR> is the new line character with the END message NL^END.

Each query produces a specific <RESPONSE MESSAGE> which is listed along with the command in the REMOTE COMMANDS section.

<WHITE SPACE> is ignored except in command identifiers. e.g. '*C LS' is not equivalent to '*CLS'. <WHITE SPACE> is defined as character codes 00H to 20H inclusive with the exception of the NL character (0AH).

The high bit of all characters is ignored.

The commands are case insensitive.

Remote Commands

The following section lists all commands and queries implemented in this instrument. For simplicity, commands are grouped by function. The REMOTE COMMAND SUMMARY lists the commands in alphabetical order, for reference.

Note that there are no dependent parameters, coupled parameters, overlapping commands, expression program data elements or compound command program headers and that each command is completely executed before the next command is started. All commands are sequential and the operation complete message is generated immediately after execution in all cases.

The following nomenclature is used:

<pmt>	<PROGRAM MESSAGE TERMINATOR>
<rmt>	<RESPONSE MESSAGE TERMINATOR>
<cpd>	<CHARACTER PROGRAM DATA>, i.e. a short mnemonic or string such as ON or OFF.
<nrf>	A number in any format. e.g. 12, 12.00, 1.2 e1 and 120 e-1 are all accepted as the number 12. Any number, when received, is converted to the required precision consistent with the use then rounded up to obtain the value of the command.
<nr1>	A number with no fractional part, i.e. an integer.
<nr2>	A number in fixed point format, e.g. 11.52, 0.78 etc.
[...]	Any item(s) enclosed in these brackets are optional parameters. If more than one item is enclosed then all or none of the items are required.

The commands which begin with a * are those specified by IEEE Std. 488.2 as Common commands. All will function when used on the RS232 interface but some are of little use.

Frequency and Period

These commands set the frequency/period of the generator main output and are equivalent to pressing the FREQ key and editing that screen.

WAVFREQ <nrf>	Set the waveform frequency to <nrf> Hz.
WAVPER <nrf>	Set the waveform period to <nrf> sec.
CLKFREQ <nrf>	Set the arbitrary sample clock freq to <nrf> Hz.
CLKPER <nrf>	Set the arbitrary sample clock period to <nrf> sec.

Amplitude and DC Offset

AMPL <nrf>	Set the amplitude to <nrf> in the units as specified by the AMPUNIT command.
AMPUNIT <cpd>	Set the amplitude units to <VPP>, <VRMS> or <DBM>.
ZLOAD <cpd>	Set the output load, which the generator is to assume for amplitude and dc offset entries, to <50> (50 Ω), <600> (600 Ω) or <OPEN>.
DCOFFS <nrf>	Set the dc offset to <nrf> Volts.

Waveform Selection and Definition

WAVE <cpd>	Select the output waveform as <SINE>, <SQUARE>, <TRIANG>, <DC>, <POSAMP>, <NEGRAMP>, <COSINE>, <HVSIN>, <HVCOS>, <SINC>, <PULSE>, <PULSTRN>, <ARB> or <SEQ>.
PULSPER <nrf>	Set the pulse period to <nrf> sec.
PULSWID <nrf>	Set the pulse width to <nrf> sec.
PULSDLY <nrf>	Set the pulse delay to <nrf> sec.
PULTRNLEN <nrf>	Set the number of pulses in the pulse-train to <nrf>.
PULTRNPER <nrf>	Set the pulse-train period to <nrf> sec.
PULTRNBASE <nrf>	Set the pulse-train base line to <nrf> Volts.
PULTRNLEV <nrf1>,<nrf2>	Set the level of pulse-train pulse number <nrf1> to <nrf2> Volts.
PULTRNWID <nrf1>,<nrf2>	Set the width of pulse-train pulse number <nrf1> to <nrf2> sec.
PULTRNDLY <nrf1>,<nrf2>	Set the delay of pulse-train pulse number <nrf1> to <nrf2> sec.
PULTRNMAKE	Makes the pulse-train and runs it - similar to the WAVE PULSTRN command.
ARB <cpd>	Select an arbitrary waveform for output. <cpd> must be the name of an existing arbitrary waveform.
ARBLIST?	Returns a list of all arbitrary waveforms, each will return a name and length in the following form <cpd>,<nrf1>. The list will end with <rmt>.
ARBCREATE <cpd>,<nrf>	Create a new, blank arbitrary waveform with name <cpd> and length <nrf> points.
ARBDATACSV <cpd>, <csv ascii data>	Load data to an existing arbitrary waveform. <cpd> must be the name of an existing arbitrary waveform. The data consists of ascii coded values, in the range -2048 to +2047, for each point. The values are separated by a comma character and the data ends with <pmt>. The data is entered into the arbitrary waveform between the points specified by the ARBLIMITS command. If less data is sent than the number of points between the limits the old data is retained from the point where the new data ends. If more data is sent the extra is discarded.
ARBDATA <cpd>, <bin data block>	Load data to an existing arbitrary waveform. <cpd> must be the name of an existing arbitrary waveform. The data consists of two bytes per point with no characters between bytes or points. The point data is sent high byte first. The data block has a header which consists of the # character followed by several ascii coded numeric characters. The first if these defines the number of ascii characters to follow and these following characters define the length of the binary data in bytes. The data is entered into the arbitrary waveform between the points specified by the ARBLIMITS command. If less data is sent than the number of points between the limits the old data is retained from the point where the new data ends. If more data is sent the extra is discarded. Due to the binary data block this command cannot be used over the RS232 interface.
ARBDATACSV? <cpd>	Returns the data from an existing arbitrary waveform. <cpd> must be the name of an existing arbitrary waveform. The data consists of ascii coded values as specified for the ARBDATACSV command. The data is sent from the arbitrary waveform between the points

	specified by the ARBLIMITS command.
ARBDATA? <cpd>	Returns the data from an existing arbitrary waveform. <cpd> must be the name of an existing arbitrary waveform. The data consists of binary coded values as specified for the ARBDATA command. The data is sent from the arbitrary waveform between the points specified by the ARBLIMITS command. Due to the binary data block this command cannot be used over the RS232 interface.
ARBDEFCSV <cpd>,<nrf>,<csv ascii data>	Define a new or existing arbitrary waveform with name <cpd> and length <nrf> and load with the data in <csv ascii data>. If the arbitrary waveform does not exist it will be created. If it does exist the length will be checked against that specified and a warning will be issued if they are different and the limits will be set to the extremes of the waveform, in either case the data will be accepted and loaded as follows. The data consists of ascii coded values, in the range -2048 to +2047, for each point. The values are separated by a comma character and the data ends with <pmt>. If less data is sent than the number of points in the waveform the old data is retained from the point where the new data ends. If more data is sent the extra is discarded.
ARBDEF <cpd>,<nrf>,<bin data block>	Define a new or existing arbitrary waveform with name <cpd> and length <nrf> and load with the data in <bin data block>. If the arbitrary waveform does not exist it will be created. If it does exist the length will be checked against that specified and a warning will be issued if they are different and the limits will be set to the extremes of the waveform, in either case the data will be accepted and loaded as follows. The data consists of two bytes per point with no characters between bytes or points. The point data is sent high byte first. The data block has a header which consists of the # character followed by several ascii coded numeric characters. The first if these defines the number of ascii characters to follow and these following characters define the length of the binary data in bytes. If less data is sent than the number of points in the waveform the old data is retained from the point where the new data ends. If more data is sent the extra is discarded. Due to the binary data block this command cannot be used over the RS232 interface.

Waveform Sequence Control

SEQWFM <nrf>,<cpd>	Set the 'waveform' parameter for sequence segment <nrf> to <cpd>. <cpd> must be the name of an existing arbitrary waveform.
SEQSTEP <nrf>,<cpd>	Set the 'step on' parameter for sequence segment <nrf> to <COUNT>, <TRGEDGE> or <TRGLEV>.
SEQCNT <nrf1>,<nrf2>	Set count for sequence segment <nrf1> to <nrf2>.
SEQSEG <nrf>,<cpd>	Set the status of sequence segment <nrf> to <ON> or <OFF>.

Arbitrary Waveform Editing

ARBLIMITS <cpd>,<nrf1>,<nrf2>	Set the limits for the arbitrary waveform with name <cpd> to start at <nrf1> and stop at <nrf2>.
ARBRESIZE <cpd>,<nrf>	Change the size of arbitrary waveform <cpd> to <nrf>.
ARBRENAME <cpd1>,<cpd2>	Change the name of arbitrary waveform <cpd1> to <cpd2>.
ARBDELETE <cpd>	Delete the arbitrary waveform <cpd>.
ARBPOINT <cpd>,<nrf1>,<nrf2>	Set the waveform point at address <nrf1> in arbitrary waveform <cpd> to <nrf2>.
ARBLINE <cpd>,<nrf1>,<nrf2>,<nrf3>,<nrf4>	Draw a line in arbitrary waveform <cpd> from start address/data <nrf1>/<nrf2> to stop address/data <nrf3>/<nrf4>.
ARBINSSTD <cpd1>,<cpd2>,<nrf1>,<nrf2>	Insert the standard waveform <cpd2> into the arbitrary waveform <cpd1> from start address <nrf1> to stop address <nrf2>. <cpd2> must be one of <SINE>, <SQUARE>, <TRIANG>, <DC>, <POSRMP>, <NEGRMP>, <COSINE>, <HAVSIN>, <HAVCOS>, or <SINC> and <cpd1> must be an existing arbitrary waveform.
ARBINSARB <cpd1>,<cpd2>,<nrf1>,<nrf2>	Insert the arbitrary waveform <cpd2> into arbitrary waveform <cpd1>. Use that part of <cpd2> specified by the ARBLIMITS command and insert from start address <nrf1> to stop address <nrf2>. <cpd1> and <cpd2> must both be existing arbitrary waveforms but they cannot be the same waveform.
ARBCOPY <cpd>,<nrf1>,<nrf2>,<nrf3>	Block copy in arbitrary waveform <cpd> the data from start address <nrf1> to stop address <nrf2> to destination address <nrf3>.
ARBAMPL <cpd>,<nrf1>,<nrf2>,<nrf3>	Adjust the amplitude of arbitrary waveform <cpd> from start address <nrf1> to stop address <nrf2> by the factor <nrf3>.
ARBOFFSET <cpd>,<nrf1>,<nrf2>,<nrf3>	Move the data in arbitrary waveform <cpd> from start address <nrf1> to stop address <nrf2> by the offset <nrf3>.
ARBINVERT <cpd>,<nrf1>,<nrf2>	Invert arbitrary waveform <cpd> between start address <nrf1> and stop address <nrf2>.
ARBLLEN? <cpd>	Returns the length, in points, of the arbitrary waveform <cpd>. If the waveform does not exist the return value will be 0.
POSNMKRCLR <cpd>	Clear all position markers from arbitrary waveform <cpd>.
POSNMKRSET <cpd>,<nrf>	Set the position marker at address <nrf> in arbitrary waveform <cpd> to 1 (high).
POSNMKRRES <cpd>,<nrf>	Clear the position marker at address <nrf> in arbitrary waveform <cpd> to 0 (low).
POSNMKRPAT <cpd1>,<nrf1>,<nrf2>,<cpd2>	Put the pattern <cpd2> into the arbitrary waveform <cpd1> from start address <nrf1> to stop address <nrf2>. The pattern may contain up to 16 entries of '1' or '0', no other characters are allowed.

Mode Commands

MODE <cpd>	Set the mode to <CONT>, <GATE>, <TRIG>, <SWEEP> or TONE
BSTCNT <nrf>	Set the burst count to <nrf>.
BSTCLK <cpd>	Set the burst counter clock to <POSNMKR> or <WFMSYNC>.
TONEFREQ <nrf1>,<nrf2>	Set tone frequency number <nrf1> to <nrf2> Hz.
TONEEND <nrf>	Delete tone frequency number <nrf> thus defining the end of the list.
SWPSTARTFRQ <nrf>	Set the sweep start frequency to <nrf> Hz.
SWPSTOPFRQ <nrf>	Set the sweep stop frequency to <nrf> Hz.
SWPCENTFRQ <nrf>	Set the sweep center frequency to <nrf> Hz.
SWPSPAN <nrf>	Set the sweep frequency span to <nrf> Hz.
SWPTIME <nrf>	Set the sweep time to <nrf> sec.
SWPTYPE <cpd>	Set the sweep type to <CONT>, <TRIG>, <THLDRST> or <MANUAL>.
SWPDIRN <cpd>	Set the sweep direction to <UP> or <DOWN>.
SWPSYNC <cpd>	Set the sweep sync <ON> or <OFF>.
SWPSPACING <cpd>	Set the sweep spacing to <LIN> or <LOG>.
SWPMKR <nrf>	Set the sweep marker to <nrf> Hz.
SWPMANUAL <cpd>	Set the sweep manual parameters to <UP>, <DOWN>, <FAST>, <SLOW>, <WRAPON> or <WRAPOFF>.

Input/Output control

OUTPUT <cpd>	Set the main output <ON>, <OFF>, <NORMAL> or <INVERT>.
SYNCOUT <cpd>	Set the sync output <ON>, <OFF>, <AUTO>, <WFMSYNC>, <POSNMKR>, <BSTDONE>, <SEQSYNC>, <TRIGGER>, <SWPTRG> or <PHASLOC>.
TRIGIN <cpd>	Set the trig input to <INT>, <EXT>, <MAN>, <POS> or <NEG>.
TRIGPER <nrf>	Set the internal trigger generator period to <nrf> sec.
VCAIN <cpd>	Set the vca/sum input to <VCA>, <SUM> or <OFF>.
REFCLK <cpd>	Set the ref. clock bnc to <IN>, <OUT>, <MASTER> or <SLAVE>.
PHASE <nrf>	Set the slave generator phase to <nrf> degrees.
ABORT	Aborts a phase locking operation.

Status Commands

*CLS	Clear status. Clears the Standard Event Status Register, Query Error Register and Execution Error Register. This indirectly clears the Status Byte Register.
*ESE <nrf>	Set the Standard Event Status Enable Register to the value of <nrf>.
*ESE?	Returns the value in the Standard Event Status Enable Register in <nr1> numeric format. The syntax of the response is <nr1><rmt>.
*ESR?	Returns the value in the Standard Event Status Register in <nr1> numeric format. The register is then cleared. The syntax of the response is <nr1><rmt>.
*IDN?	Returns the instrument identification. The exact response is determined by the instrument configuration and is of the form WAVETEK, MODEL 39, 0, 1.0 (or later issue of software installed).
*IST?	Returns ist local message as defined by IEEE Std. 488.2. The syntax of the response is 0<rmt>, if the local message false or 1<rmt>, if the local message is true.
*OPC	Sets the Operation Complete bit (bit 0) in the Standard Event Status Register. This will happen immediately the command is executed because of the sequential nature of all operations.
*OPC?	Query operation complete status. The syntax of the response is 1<rmt>. The response will be available immediately the command is executed because of the sequential nature of all operations.
*PRE <nrf>	Set the Parallel Poll Enable Register to the value <nrf>.
*PRE?	Returns the value in the Parallel Poll Enable Register in <nr1> numeric format. The syntax of the response is <nr1><rmt>.
*SRE <nrf>	Set the Service Request Enable Register to <nrf>. If the value of <nrf>.
*SRE?	Returns the value of the Service Request Enable Register in <nr1> numeric format. The Syntax of the response is <nr1><rmt>.
*STB?	Returns the value of the Status Byte Register in <nr1> numeric format. The syntax of the response is <nr1><rmt>.
*WAI	Wait for operation complete true. As all commands are completely executed before the next is started this command takes no additional action.
*TST?	The generator has no self-test capability and the response is always 0<rmt>.
EER?	Query and clear execution error number register. The response format is nr1<rmt>.
QER?	Query and clear query error number register. The response format is nr1<rmt>.

Miscellaneous Commands

*LRN?	Returns the complete set up of the instrument as a hexadecimal character data block approximately 842 bytes long. To re-install the set up the block should be returned to the instrument exactly as it is received. The syntax of the response is LRN <Character data><rmt>. The settings in the instrument are not affected by execution of the *LRN? command.
LRN <character data>	Install data for a previous *LRN? command.
*RST	Resets the instrument parameters to their default values (see DEFAULT INSTRUMENT SETTINGS).
*RCL <nrf>	Recalls the instrument set up contained in store number <nrf>. Valid store numbers are 0 - 9. Recalling store 0 sets all parameters to the default settings (see DEFAULT INSTRUMENT SETTINGS).
*SAV <nrf>	Saves the complete instrument set up in the store number <nrf>. Valid store numbers are 1 - 9.
*TRG	This command is the same as pressing the MAN/SYNC key. Its effect will depend on the context in which it is asserted.
HOLD <cpd>	Set hold mode <ON> or <OFF>. This is the same as pressing the HOLD key.
FILTER <cpd>	Set the output filter to <AUTO>, <ELIP>, <BESS> or <NONE>.
BEEPMODE <cpd>	Set beep mode to <ON>, <OFF>, <WARN>, or <ERROR>.
BEEP	Sound one beep.
LOCAL	Returns the instrument to local operation and unlocks the keyboard. Will not function if LLO is in force.

Refer to Calibration section for remote calibration commands.

Remote Command Summary

*CLS	Clear status.
*ESE <nrf>	Set the Standard Event Status Enable Register to the value of <nrf>.
*ESE?	Returns the value in the Standard Event Status Enable Register in <nrf1> numeric format.
*ESR?	Returns the value in the Standard Event Status Register in <nrf1> numeric format.
*IDN?	Returns the instrument identification.
*IST?	Returns the local message as defined by IEEE Std. 488.2.
*LRN?	Returns the complete set up of the instrument as a hexadecimal character data block approximately 842 bytes long.
*OPC	Sets the Operation Complete bit (bit 0) in the Standard Event Status Register.
*OPC?	Query operation complete status.
*PRE <nrf>	Set the Parallel Poll Enable Register to the value <nrf>.
*PRE?	Returns the value in the Parallel Poll Enable Register in <nrf1> numeric format.
*RCL <nrf>	Recalls the instrument set up contained in store number <nrf>.
*RST	Resets the instrument parameters to their default values.
*SAV	Saves the complete instrument set up in the store number <nrf>. Valid store numbers are 1 - 9.
*SRE <nrf>	Set the Service Request Enable Register to <nrf>.
*SRE?	Returns the value of the Service Request Enable Register in <nrf1> numeric format.
*STB?	Returns the value of the Status Byte Register in <nrf1> numeric format.
*TRG	This command is the same as pressing the MAN/SYNC key.
*TST?	The generator has no self-test capability and the response is always 0<rmt>.
*WAI	Wait for operation complete true. executed before the next is started
ABORT	Aborts a phase locking operation.
AMPL <nrf>	Set the amplitude to <nrf> in the units as specified by the AMPUNIT command.
AMPUNIT <cpd>	Set the amplitude units to <VPP>, <VRMS> or <DBM>.
ARB <cpd>	Select an arbitrary waveform for output.
ARBAMPL <cpd>,<nrf1>,<nrf2>,<nrf3>	Adjust the amplitude of arbitrary waveform <cpd> from start address <nrf1> to stop address <nrf2> by the factor <nrf3>.
ARBCOPY <cpd>,<nrf1>,<nrf2>,<nrf3>	Block copy in arbitrary waveform <cpd> the data from start address <nrf1> to stop address <nrf2> to destination address <nrf3>.
ARBCREATE <cpd>,<nrf>	Create a new, blank arbitrary waveform with name <cpd> and length <nrf> points.
ARBDATA <cpd>,&br/>	Load data to an existing arbitrary waveform.

<bin data block>	
ARBDATA? <cpd>	Returns the data from an existing arbitrary waveform.
ARBDATACSV <cpd>,<csv ascii data>	Load data to an existing arbitrary waveform.
ARBDATACSV? <cpd>	Returns the data from an existing arbitrary waveform.
ARBDEF <cpd>,<nrf>, <bin data block>	Define a new or existing arbitrary waveform with name <cpd> and length <nrf> and load with the data in <bin data block>.
ARBDEFCSV <cpd>,<nrf>, <csv ascii data>	Define a new or existing arbitrary waveform with name <cpd> and length <nrf> and load with the data in <csv ascii data>.
ARBDELETE <cpd>	Delete the arbitrary waveform <cpd>.
ARBINSARB <cpd1>,<cpd2>,<nrf1>,<nrf2>	Insert the arbitrary waveform <cpd2> into arbitrary waveform <cpd1>. Use that part of <cpd2> specified by the ARBLIMITS command and insert from start address <nrf1> to stop address <nrf2>.
ARBINSSTD <cpd1>,<cpd2>,<nrf1>,<nrf2>	Insert the standard waveform <cpd2> into the arbitrary waveform <cpd1> from start address <nrf1> to stop address <nrf2>.
ARBINVERT <cpd>,<nrf1>,<nrf2>	Invert arbitrary waveform <cpd> between start address <nrf1> and stop address <nrf2>.
ARBLEN? <cpd>	Returns the length, in points, of the arbitrary waveform <cpd>.
ARBLIMITS <cpd>,<nrf1>,<nrf2>	Set the limits for the arbitrary waveform with name <cpd> to start at <nrf1> and stop at <nrf2>.
ARBLINE <cpd>,<nrf1>,<nrf2>, <nrf3>,<nrf4>	Draw a line in arbitrary waveform <cpd> from start address/data <nrf1>/<nrf2> to stop address/data <nrf3>/<nrf4>.
ARBLIST?	Returns a list of all arbitrary waveforms, each will return a name and length in the following form <cpd>,<nrf1>.
ARBOFFSET <cpd>,<nrf1>,<nrf2>,<nrf3>	Move the data in arbitrary waveform <cpd> from start address <nrf1> to stop address <nrf2> by the offset <nrf3>.
ARBPOINT <cpd>,<nrf1>,<nrf2>	Set the waveform point at address <nrf1> in arbitrary waveform <cpd> to <nrf2>.
ARBRENAME <cpd1>,<cpd2>	Change the name of arbitrary waveform <cpd1> to <cpd2>.
ARBRESIZE <cpd>,<nrf>	Change the size of arbitrary waveform <cpd> to <nrf>.
BEEP	Set beep mode to <ON>, <OFF>, <WARN>, or <ERROR>.
BEEPMODE <cpd>	Sound one beep.
BSTCLK <cpd>	Set the burst counter clock to <POSNMKR> or <WFMSYNC>.
BSTCNT <nrf>	Set the burst count to <nrf>.
CLKFREQ <nrf>	Set the arbitrary sample clock freq to <nrf> Hz.
CLKPER <nrf>	Set the arbitrary sample clock period to <nrf> sec.
DCOFFS <nrf>	Set the dc offset to <nrf> Volts.
EER?	Query and clear execution error number register.
FILTER <cpd>	Set the output filter to <AUTO>, <ELIP>, <BESS> or <NONE>.
HOLD <cpd>	Set hold mode <ON> or <OFF>.
LOCAL	Returns the instrument to local operation and unlocks the keyboard. Will not function if LLO is in force.

LRN <character data>	Install data for a previous *LRN? command.
MODE <cpd>	Set the mode to <CONT>, <GATE>, <TRIG>, <SWEEP> or TONE.
OUTPUT <cpd>	Set the main output <ON>, <OFF>, <NORMAL> or <INVERT>.
PHASE <nrf>	Set the slave generator phase to <nrf> degrees.
POSNMKRCLR <cpd>	Clear all position markers from arbitrary waveform <cpd>.
POSNMKRPAT <cpd1>,<nrf1>,<nrf2>,<cpd2>	Put the pattern <cpd2> into the arbitrary waveform <cpd1> from start address <nrf1> to stop address <nrf2>.
POSNMKRRES <cpd>,<nrf>	Clear the position marker at address <nrf> in arbitrary waveform <cpd> to 0 (low).
POSNMKRSET <cpd>,<nrf>	Set the position marker at address <nrf> in arbitrary waveform <cpd> to 1 (high).
PULSDLY <nrf>	Set the pulse delay to <nrf> sec.
PULSPER <nrf>	Set the pulse period to <nrf> sec.
PULSWID <nrf>	Set the pulse width to <nrf> sec.
PULTRNBASE <nrf>	Set the pulse-train base line to <nrf> Volts.
PULTRNDLY <nrf1>,<nrf2>	Set the delay of pulse-train pulse number <nrf1> to <nrf2> sec.
PULTRNLEN <nrf>	Set the number of pulses in the pulse-train to <nrf>.
PULTRNLEV <nrf1>,<nrf2>	Set the level of pulse-train pulse number <nrf1> to <nrf2> Volts.
PULTRNMAKE	Makes the pulse-train and runs it - similar to the WAVE PULSTRN command.
PULTRNPER <nrf>	Set the pulse-train period to <nrf> sec.
PULTRNWID <nrf1>,<nrf2>	Set the width of pulse-train pulse number <nrf1> to <nrf2> sec.
QER?	Query and clear query error number register.
REFCLK <cpd>	Set the ref. clock bnc to <IN>, <OUT>, <MASTER> or <SLAVE>.
SEQCNT <nrf1>,<nrf2>	Set count for sequence segment <nrf1> to <nrf2>.
SEQSEG <nrf>,<cpd>	Set the status of sequence segment <nrf> to <ON> or <OFF>.
SEQSTEP <nrf>,<cpd>	Set the 'step on' parameter for sequence segment <nrf> to <COUNT>, <TRGEDGE> or <TRGLEV>.
SEQWFM <nrf>,<cpd>	Set the 'waveform' parameter for sequence segment <nrf> to <cpd>.
SWPCENTFRQ <nrf>	Set the sweep center frequency to <nrf> Hz.
SWPDIRN <cpd>	Set the sweep direction to <UP> or <DOWN>.
SWPMANUAL <cpd>	Set the sweep manual parameters to <UP>, <DOWN>, <FAST>, <SLOW>, <WRAPON> or <WRAPOFF>.
SWPMKR <nrf>	Set the sweep marker to <nrf> Hz.
SWSPACING <cpd>	Set the sweep spacing to <LIN> or <LOG>.
SWSPAN <nrf>	Set the sweep frequency span to <nrf> Hz.
SWPSTARTFRQ <nrf>	Set the sweep start frequency to <nrf> Hz.
SWPSTOPFRQ <nrf>	Set the sweep stop frequency to <nrf> Hz.
SWPSYNC <cpd>	Set the sweep sync <ON> or <OFF>.
SWPTIME <nrf>	Set the sweep time to <nrf> sec.

SWPTYPE <cpd>	Set ten sweep type to <CONT>, <TRIG>, <THLDRST> or <MANUAL>.
SYNCOUT <cpd>	Set the sync output <ON>, <OFF>, <AUTO>, <WFMSYNC>, <POSNMKR>, <BSTDONE>, <SEQSYNC>, <TRIGGER>, <SWPTRG> or <PHASLOC>.
TONEEND <nrf>	Delete tone frequency number <nrf> thus defining the end of the list.
TONEFREQ <nrf1>,<nrf2>	Set tone frequency number <nrf1> to <nrf2> Hz.
TRIGIN <cpd>	Set the trig input to <INT>, <EXT>, <MAN>, <POS> or <NEG>.
TRIGPER <nrf>	Set the internal trigger generator period to <nrf> sec.
VCAIN <cpd>	Set the vca/sum input to <VCA>, <SUM> or <OFF>.
WAVE <cpd>	Select the output waveform as <SINE>, <SQUARE>, <TRIANG>, <DC>, <POSRMP>, <NEGRMP>, <COSINE>, <HAVSIN>, <HAVCOS>, <SINC>, <PULSE>, <PULSTRN>, <ARB> or <SEQ>.
WAVFREQ <nrf>	Set the waveform frequency to <nrf> Hz.
WAVPER <nrf>	Set the waveform period to <nrf> sec.
ZLOAD <cpd>	Set the output load, which the generator is to assume for amplitude and dc offset entries, to <50> (50Ω), <600> (600Ω) or <OPEN>.

Refer to Calibration section for remote calibration commands.

Appendix 1. Warning and Error Messages

Warning messages are given when a setting may not give the expected result, e.g. DC Offset attenuated by the output attenuator when a small amplitude is set; the setting is, however, implemented.

Error messages are given when an illegal setting is attempted; the previous setting is retained.

The last two warning/error messages can be reviewed by selecting LAST ERROR from the UTILITY screen, the latest is reported first.

Warning and error messages are reported with a number on the display; only the number is reported via the remote control interfaces.

The following is a complete list of messages as they appear on the display.

Warning Messages

- 00 No errors or warnings have been reported
- 13 DC offset changed by amplitude
- 14 DC offset + level may cause clipping
- 23 Offset will clip the waveform
- 24 This instrument is not calibrated
- 30 Amplitude will clip the waveform
- 37 Trigger generator maximum resolution is 20ns
- 40 Arb length less than 10 points. May give unpredictable result
- 42 Trigger source is fixed to external in TONE/SWP/SLAVE mode
- 43 Arb repeated in two seq segs so SEQ SYNC may not be correct
- 59 Trigger slope is fixed to positive in SWEEP/SLAVE mode

Error Messages

- 101 Frequency out of range for the selected waveform
- 102 Sample clock frequency required exceeds 30MHz
- 103 Sample clock frequency required is less than 0.1Hz
- 104 Pulse/pulse-train period out of range for current set-up
- 105 Pulse width cannot be greater than the period
- 106 Absolute value of pulse delay must be < period
- 107 Pulse width cannot be less than 33.33ns
- 108 Maximum output level exceeded
- 109 Minimum output level exceeded
- 110 Minimum dc offset value exceeded
- 111 Maximum dc offset value exceeded
- 112 The value entered is out of range
- 115 There are no arb waveforms defined Use WAVEFORM CREATE
- 116 Cannot delete arb while it is selected for output
- 117 Arb name exists, names must be unique
- 118 Arb waveform length exceeds available memory

-
- 119 Arb waveform length cannot be less than four points
 - 120 Waveform limit value out of range
 - 121 Start address error: must be in the range $0 \leq n \leq \text{stop addr}$
 - 122 Stop address error: must be in the range $\text{strt} \leq n \leq \text{wfm len}$
 - 125 No GPIB interface is available
 - 127 System ram error check battery
 - 128 Point value error: must be in the range $-2048 \leq n \leq +2047$
 - 129 Wave offset error: must be in the range $-4096 \leq n \leq +4095$
 - 131 Wave amplitude error must be in the range $0 \leq n \leq 100$
 - 132 Block dest error: must be in the range $0 \leq n \leq \text{wfm len}-4$
 - 133 Sequence count value exceeds the maximum of 32768
 - 134 Sequence count value cannot be less than 1
 - 135 Trigger generator maximum period is 200s
 - 136 Trigger generator minimum period is 20us
 - 138 Burst count value exceeds the maximum of 1048575
 - 139 Burst count value cannot be less than 1
 - 141 Selected function is illegal in tone mode TONE MODE CANCELED!
 - 144 Selected combination of function and mode is illegal
 - 145 Selected mode is not available when phase lock master or slave
 - 146 Cannot delete arbs while a sequence is running
 - 147 Sequence set-up requires an arb wfm which does not exist
 - 148 Trig/gate mode and seq step value cause a trigger conflict
 - 149 Seq step value can't mix edge and level between segments
 - 150 Number of pulses in train must be between 1 and 10
 - 151 Pulse train base level must be $>-5.0V$ and $<+5.0V$
 - 152 Pulse level must be $>-5.0V$ and $<+5.0V$
 - 153 Pulse number must be between 1 and 10
 - 154 Sweep frequency values must be 1mHz to 10MHz
 - 155 Sweep start freq must be less than stop freq
 - 156 Sweep stop freq must be greater than start freq
 - 157 Sweep time value is out of range $0.03s < n < 999s$
 - 158 Sweep marker value is out of range $0.001Hz < n < 10MHz$
 - 160 Unable to phase lock to master
 - 161 Illegal phase value

Remote Warnings

- 72 Length is different to that in the ARBDEF(CSV) command

Remote Errors

- 126 Illegal store number requested
- 162 Byte value outside the range 0 to 255
- 163 Specified arb name does not exist
- 164 Command illegal in sweep or tone mode
- 165 Cannot set waveform frequency or period for a sequence
- 166 Cannot set sample frequency or period for std waveforms
- 167 dBm output units assume a 50 Ohm termination
- 168 Specified units illegal for the selected waveform
- 169 Command not available for RS232
- 170 Length value error in binary block
- 171 Illegal value in arbitrary data
- 173 Illegal tone number
- 174 Illegal sequence segment number
- 175 Cannot insert arb into itself
- 176 Pattern value is illegal or pattern too long
- 177 Illegal remote calibration command.

Appendix 2. SYNC OUT Automatic Settings

The following automatic source (src) settings are made when **auto** mode is selected on the **SYNC OUTPUT SETUP** screen.

MODE	WAVEFORM	Wavefor m Sync	Position Marker	Burst Done	Sequence Sync	Trigger	Sweep Trigger	Pha: Loc
Continuous	Standard	✓						
	Arbitrary	✓						
	Sequence				✓			
Gate/Trig	All					✓		
Sweep	All						✓	
Tone	All					✓		
Phase Lock Master	Sequence				✓			
	All other							✓

Appendix 3. Factory System Defaults

The factory system defaults are listed in full below. They can be recalled by pressing RECALL followed by `set defaults` or by the remote command `*RST`.

Main Parameters

Std. Wave: Sine
Frequency: 10kHz
Output: +2.0Vpp ; Output Off
DC Offset: 0V
Zout: HiZ

Gate/Trigger Parameters

Source: Internal
Period: 1ms
Slope: Positive
Burst Count: 1
Clk Wfm Sync

VCA/Sum Off

Sweep Parameters

Begin Frequency: 100kHz
End Frequency: 10MHz
Marker Frequency: 5MHz
Direction: Up
Spacing: Log
Sweep Time: -50ms
Type: Continuous

Filter Auto
Sync Out Auto
Sequence (all segments set as follows)
Status: Off except seg 1.
Wfm: First arb
Step ON Count
Count: 1

Arbitrary All unaffected by reset or *RST.