

INSTRUCTION MANUAL  
**MODEL 2002A**  
SWEEP/SIGNAL GENERATOR

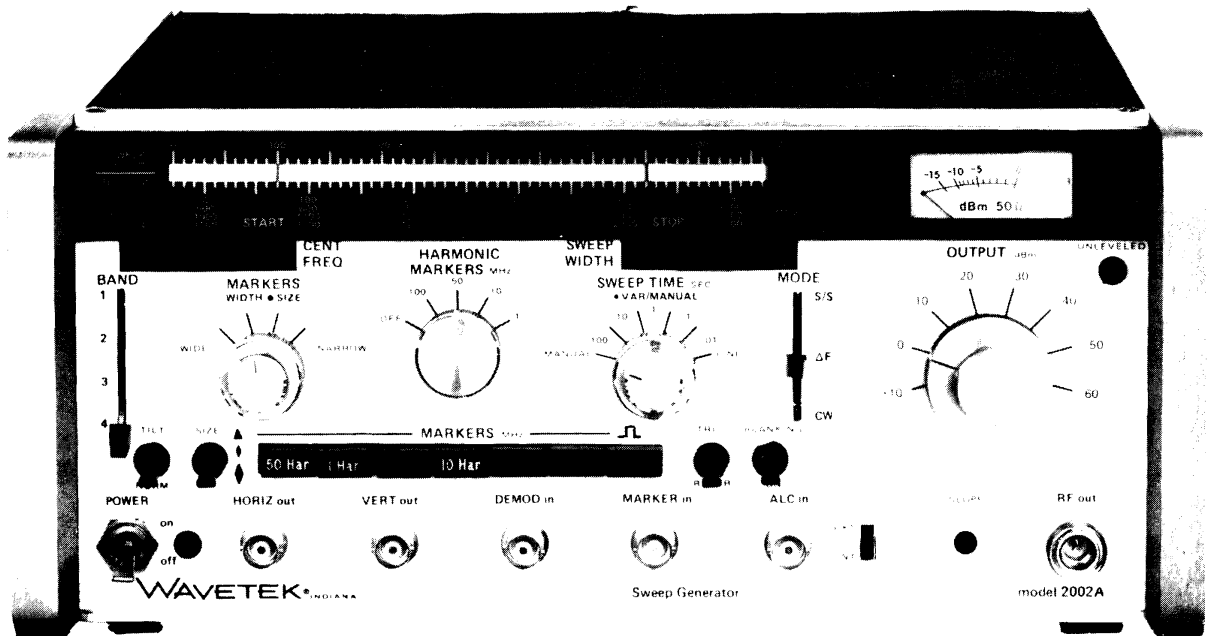

© - 1979 - WAVETEK

THIS DOCUMENT CONTAINS INFORMATION PROPRIETARY TO WAVETEK. THE INFORMATION IN THIS DOCUMENT IS NOT TO BE USED OR DUPLICATED IN ANY MANNER WITHOUT THE PRIOR APPROVAL, IN WRITING OF WAVETEK.

**WAVETEK** INDIANA INC.

66 N. FIRST AVENUE, P.O. BOX 190

BEECH GROVE, INDIANA 46107

317-783-3221

2/80

# Scans By *Artek Media*

Artek Media  
1042 Plummer Cir. SW  
Rochester, MN 55902

[www.artekmedia.com](http://www.artekmedia.com)

“High resolution scans of obsolete technical manuals”

If you are looking for a quality scanned technical manual in PDF format please visit our WEB site at [www.artekmedia.com](http://www.artekmedia.com) or drop us an email at [manuals@artekmedia.com](mailto:manuals@artekmedia.com) and we will be happy to email you a current list of the manuals we have available.

If you don't see the manual you need on the list drop us a line anyway we may still be able to point you to other sources. If you have an existing manual you would like scanned please write for details, This can often be done very reasonably in consideration for adding your manual to our library.

Typically the scans in our manuals are done as follows;

- 1) Typed text pages are typically scanned in black and white at 300 dpi.
- 2) Photo pages are typically scanned in gray scale mode at 600 dpi
- 3) Schematic diagram pages are typically scanned in black and white at 600 dpi unless the original manual had colored high lighting (as is the case for some 70's vintage Tektronix manuals).

If you purchased this manual from us (typically through our Ebay name of ArtekMedia) thank you very much. If you received this from a well-meaning “friend” for free we would appreciate your treating this much like you would “share ware”. By that we mean a donation of at least \$5-10 per manual is appreciated in recognition of the time (a manual can take as much as 40 hours to reproduce, book, link etc.), energy and quality of effort that went into preserving this manual. Donations via PayPal go to: [manuals@artekmedia.com](mailto:manuals@artekmedia.com) or can be mailed to us the address above.

Thanks



Dave & Lynn Henderson  
Artek Media

# WARRANTY

All Wavetek instruments are warranted against defects in material and workmanship for a period of one year after date of manufacture. Wavetek agrees to repair or replace any assembly or component (except batteries) found to be defective under normal use during this period. Transfermatic Switch assemblies, manufactured by Wavetek, are unconditionally warranted for the life of the instrument. Wavetek's obligation under this warranty is limited solely to repairing any such instrument which, in Wavetek's sole opinion, proves to be defective within the scope of the warranty when returned to the factory or to an authorized service center. Transportation to the factory or service center is to be prepaid by purchaser. Shipment should not be made without prior authorization by Wavetek.

This warranty does not apply to any products repaired or altered by persons not authorized by Wavetek, or not in accordance with instructions furnished by Wavetek. If the instrument is defective as a result of misuse, improper repair, or abnormal conditions or operations, repairs will be billed at cost.

Wavetek assumes no responsibility for its product being used in a hazardous or dangerous manner either alone or in conjunction with other equipment. High voltage used in some instruments may be dangerous if misused. Special disclaimers apply to these instruments. Wavetek assumes no liability for secondary charges or consequential damages and, in any event, Wavetek's liability for breach of warranty under any contract or otherwise shall not exceed the purchase price of the specific instrument shipped and against which a claim is made.

Any recommendations made by Wavetek for use of its products are based upon tests believed to be reliable, but Wavetek makes no warranty of the results to be obtained. This warranty is in lieu of all other warranties, expressed or implied, and no representative or person is authorized to represent or assume for Wavetek any liability in connection with the sale of our products other than set forth herein.

## SCOPE OF THIS MANUAL

This manual provides descriptive material and instructions for the installation, operation, maintenance, and repair of the WAVETEK Model 2002A Sweep/Signal Generator.

# CONTENTS

## SECTION 1 – GENERAL INFORMATION

- 1.1 INTRODUCTION
- 1.2 SPECIFICATIONS
- 1.3 OPTIONS
- 1.4 ACCESSORIES

## SECTION 2 – OPERATION

- 2.1 INTRODUCTION
- 2.2 MECHANICAL INSTALLATION
- 2.3 ELECTRICAL INSTALLATION
- 2.4 DESCRIPTION OF FRONT PANEL
- 2.5 DESCRIPTION OF REAR PANEL
- 2.6 TYPICAL OPERATING SET-UP
- 2.7 SPECIAL OPERATING NOTES
- 2.8 PROGRAMMING

## SECTION 3 – THEORY OF OPERATION

- 3.1 INTRODUCTION
- 3.2 BLOCK DIAGRAM
- 3.3 DPS2A – POWER SUPPLY
- 3.4 M101B – SWEEP RATE
- 3.5 M102A – SWEEP DRIVE
- 3.6 M103A – SWEEP DRIVE
- 3.7 M104A – LEVELER
- 3.8 M105 – MARKER ADDER
- 3.9 M109 – SWEEP OSCILLATOR 1
- 3.10 M110 – SWEEP OSCILLATORS 2A, 2B, AND 3
- 3.11 MA111 – OUTPUT AMPLIFIER
- 3.12 M121 – MODULATOR
- 3.13 M131 – BAND SELECT
- 3.14 M132 – INTERFACE

## SECTION 4 – PERFORMANCE TESTS

- 4.1 INTRODUCTION
- 4.2 FREQUENCY RANGE AND ACCURACY TESTS
- 4.3 SWEEP WIDTH TEST
- 4.4 DISPLAY LINEARITY TEST
- 4.5 SPURIOUS SIGNAL TEST
- 4.6 FREQUENCY DRIFT TEST
- 4.7 BLANKING TEST
- 4.8 OUTPUT IMPEDANCE AND SWR TEST
- 4.9 RF OUTPUT MAXIMUM LEVEL TEST
- 4.10 RF OUTPUT ATTENUATION AND ACCURACY TESTS
- 4.11 RF OUTPUT FLATNESS TEST
- 4.12 SWEEP TIME (HORIZONTAL OUTPUT) TEST
- 4.13 MARKER SYSTEM TESTS
- 4.14 EXTERNAL PROGRAMMING
- 4.15 SLOPE TEST
- 4.16 1 KHZ MODULATION TEST
- 4.17 PEN LIFT (OPTION B4)

## **CONTENTS continued**

### **SECTION 5 – MAINTENANCE**

- 5.1 INTRODUCTION
- 5.2 SERVICE INFORMATION
- 5.3 CALIBRATION PROCEDURE
- 5.4 TROUBLESHOOTING
- 5.5 FIELD INSTALLATION OF OPTIONS

### **SECTION 6 – REPLACEABLE PARTS**

- 6.1 INTRODUCTION
- 6.2 MANUFACTURERS CODE
- \*\*\* PARTS LIST

### **SECTION 7 – SCHEMATICS**

- 7.1 INTRODUCTION
- 7.2 SCHEMATIC NOTES
- 7.3 SCHEMATIC INDEX
- \*\*\* SCHEMATICS

CHANGE INFORMATION, IF ANY, IS LOCATED AT THE REAR OF THIS MANUAL

# SECTION 1

## GENERAL INFORMATION

### 1.1 INTRODUCTION

The Model 2002A covers the 1 to 2500 MHz range in three bands. Band 1 is covered by a 1 to 500 MHz heterodyne sweep oscillator. Band 2 is covered by two fundamental oscillators which sweep from 500 to 1000 MHz and 1000 to 1500 MHz, respectively. Band 3 is covered by a single fundamental oscillator sweeping from 1500 to 2500 MHz. Additionally, all four oscillators may be stacked (sequentially swept) to cover the entire 1 to 2500 MHz instrument range (band 4).

Each of the four frequency bands (1-500 MHz, 500-1500 MHz, 1500-2500 MHz, and 1-2500 MHz) may be used in three modes of operation: start/stop,  $\Delta f$ , or CW. It can be swept over any portion of a given band, in either direction, at any rate from 50 sweeps per second to 1 sweep every 100 seconds. Manual, triggered, or recurring sweeps are provided. The sweep frequency, sweep width, and output attenuation may be controlled by external voltages.

Other features of the Model 2002A include a SLOPE control which compensates for frequency dependent variations in the external circuitry, and a 1 kHz square-wave modulator for low-level recovery applications.

This instrument also includes an elaborate frequency marker system. Up to five crystal-controlled birdy marker modules (single frequency or harmonic type) may be plugged into the Model 2002A. Each module has its own front-panel on/off switch. Additionally, a single module producing harmonic markers at 1, 10, 50, and 100 MHz intervals may be installed. Front-panel SIZE and WIDTH controls enable optimum adjustment of the marker display. The marker system features dual-amplitude markers for easy identification. In application, the markers may be tilted up to  $90^\circ$  for easy viewing when displayed with steep transition signals, or they may be rectified by a front-panel switch for X-Y plotter applications.

Other optional features include a rear-panel Auxilliary RF Output and a Pen Lift circuit for use with X-Y plotters.

Most optional features, as well as the functional circuits for the basic sweep generator, have modular plug-in construction. This allows optional features to be factory installed at the time of purchase, or customer installed at a later date. This concept offers protection against obsolescence, since updated and additional features can be simply and economically added as new test procedures dictate. In addition, maintenance problems can be greatly simplified by stocking several modules instead of hundreds of discrete components.

## 1.2 SPECIFICATIONS

### 1.2.1 FREQUENCY

RANGE	1 to 2500 MHz in four bands: 1-500/500-1500/1500-2500/1-2500			
SWEEP WIDTH	$\Delta f$ - 200 kHz to 500 MHz on all bands			
	S/S - 200 kHz to 500 MHz on band 1 200 kHz to 1000 MHz on bands 2, 3 1 MHz to 2500 MHz on band 4			
ACCURACY AT 25° C	CW	----- $\Delta f$ -----		S/S
		CENT FREQ	SWP WIDTH	
	Band 1	10	15	15 MHz
	Bands 2, 3	20	30	30 MHz
Band 4	50	50	50 MHz	
ACCURACY VS TEMP	500 kHz/°C			
Bands 1, 2	1 MHz/°C			
Band 3	Frequency scale calibrated in 10 MHz increments for band 1, 20 MHz increments for bands 2 and 3, and 50 MHz for band 4. $\Delta f$ sweep width is calibrated in 10 MHz intervals.			
DISPLAY LINEARITY	1% (discounting band switch discontinuities)			
BAND SWITCHING	Band switching discontinuity points occur at 500, 1000, and 1500 MHz. The discontinuity is -9 + 20 MHz. A band switching blanking output signal (approximately 15 V in magnitude, switchable polarity) occurs at the rear-panel BAND STACKING BLANKING output connector.			
SPURIOUS SIGNALS	SIGNAL FREQUENCY      SPURIOUS SIGNAL LEVEL			
HARMONICS	1 to 10 MHz		-20 dBc	
	10 to 2500 MHz		-30 dBc	
NON-HARMONICS	1 to 500 MHz		-35 dBc (1 to 500 MHz)	
	1 to 500 MHz		-30 dBc (full range)	
	500 to 2500 MHz		non detectable	
RESIDUAL FM (CW MODE)	Bands 1, 2		<10 kHz peak to peak	
	Band 3		<20 kHz peak to peak	
DRIFT	Bands 1, 2		<100 kHz/5 min.	
			<2 MHz/8 hr.	
	Band 3		<200 kHz /5 min.	
			<4 MHz/8 hr.	
	(At constant temperature after 1 hr. warm-up, and allowing a 5 minute stabilizing period after a frequency change.)			
BLANKING	A front-panel switch enables the RF output to be removed during the sweep retrace time to provide a zero volt base line.			

## 1.2.2 RF OUTPUT

IMPEDANCE	50 ohms
SWR	Less than 1.5:1 with insertion loss of 10 dB from STEP ATTENUATOR. Less than 1.3:1 with insertion of 20 dB or more from STEP ATTENUATOR.
MAXIMUM LEVEL	+13 dBm
ATTENUATION	Output continuously adjustable from +13 to -77 dBm. 70 dB in 10 dB steps plus a 20 dB vernier.
ACCURACY	STEP ATTENUATOR: 3% of attenuation (maximum error at 70 dB = $\pm 2.1$ dB). VERNIER ATTENUATOR: $\pm .5$ dB over top 13 dB of range, lower 7 dB is unspecified.
FLATNESS AT +13 dBm OUTPUT	$\pm 0.5$ dB
SLOPE	Up to $\pm 1$ dB/GHz of slope may be imposed on the RF output via the front-panel SLOPE control. The reference (pivot point) of this slope is 1 MHz. The output METER will indicate the change in output level at slow sweep rates. NOTE: The OUTPUT VERNIER must be set so that the added slope will not produce an RF output level greater than the highest possible OUTPUT VERNIER setting.
OUTPUT CONNECTOR	Type N
EXTERNAL LEVELING	An external negative monitor signal, between .2 and 2 volts, may be used to level the RF output.

## 1.2.3 SWEEP

OPERATING MODES	Start/Stop - $\Delta f$ - CW
SWEEP MODES	Repetitive sweep Single sweep Externally triggered sweep Manual sweep Line-locked sweep
SWEEP TIME	Continuously variable from less than .01 to more than 100 seconds per sweep in four decade ranges with vernier (add 1 msec for every band switch point crossed). Manual and line-locked sweep are also provided. NOTE: In line-locked sweep, the sweep time for band 4 is double that for bands 1, 2, and 3.
SWEEP DWELL	Approximately 4 msec delay at start of sweep controlled by rear-panel switch.
HORIZONTAL OUTPUT	Zero to +10 volts. Impedance 10 k $\Omega$ .



## 1.2.4 MODULATION

Square-wave modulation produces blanking of RF output at a 1 kHz rate for low-level recovery operations. On/off control is provided on the front panel.

For external AM and FM, refer to Section 1.2.6, Remote Programming.

## 1.2.5 MARKER SPECIFICATIONS

TYPE	Birdy by-pass															
EXTERNAL	Front-panel BNC connector accepts external CW signal for conversion to a birdy marker. Input level: 100 mV into 50 ohms. Front-panel on/off control is provided.															
INTERNAL	The instrument has provisions for either single frequency or harmonic type plug-in birdy marker modules. Maximum of five A1 or A2 options and one A3 option.															
Single Frequency	A1 options are individually controlled by front-panel push buttons.															
Harmonic (comb)	A2 or A3 options provide markers at multiples of the specified fundamental frequency.  A2 options produce harmonics of one crystal frequency and are individually controlled by front-panel push buttons.  A3 option is a combination 1, 10, 50, and 100 MHz harmonic marker controlled by a front-panel rotary switch.															
ACCURACY	Option A1 or A2           .005% at 25°C .007%, 0° to 50°C Option A3                 .005%, 0° to 50°C															
WIDTH	Adjustable in four steps from approximately 15 to 400 kHz.															
SIZE																
DUAL AMPLITUDE FEATURE	The instrument is capable of providing markers at two distinct amplitudes to facilitate marker identification. An internal adjustment controls the ratio of the two sizes.  Markers controlled by front-panel buttons a, b, c, and EXT (first, second, third, and sixth from left) are full-size, whereas markers controlled by buttons d and e can be set for some fraction of this size.  This feature pertains to the Deluxe Harmonic Marker (Option A3) in the following manner.															
	<table><thead><tr><th>Setting</th><th>Reducible</th><th>Full size</th></tr></thead><tbody><tr><td>1</td><td>1 MHz</td><td>10 MHz</td></tr><tr><td>10</td><td>10 MHz</td><td>100 MHz</td></tr><tr><td>50</td><td>50 MHz</td><td>100 MHz</td></tr><tr><td>100</td><td>---</td><td>100 MHz</td></tr></tbody></table>	Setting	Reducible	Full size	1	1 MHz	10 MHz	10	10 MHz	100 MHz	50	50 MHz	100 MHz	100	---	100 MHz
Setting	Reducible	Full size														
1	1 MHz	10 MHz														
10	10 MHz	100 MHz														
50	50 MHz	100 MHz														
100	---	100 MHz														

## AMPLITUDE CONTROL

All markers are continuously adjustable with front-panel controls over two ranges. The ranges for full-size markers are: 4 Vpp to 10 mVpp and 25 mVpp to 50  $\mu$ Vpp. (Voltages are approximate.)

## RECTIFICATION

Birdy markers can be rectified (positive) for use with X-Y plotters. Size varies with detector's impedance. Adjustable from approximately 2 V to 1 mV with detector impedance of 1 Megohm, or from 0.2 V to 1 mV with detector impedance of 0 ohms.

## TILT

This feature adds to the normally vertical marker a horizontal component with an amplitude of about 10% of horizontal scope display. The marker amplitude control affects only the vertical component; therefore, the marker is adjustable from a horizontal position to an angle approaching vertical as the MARKER SIZE control setting is increased.

## 1.2.6 REMOTE PROGRAMMING

A rear-panel PROGRAMMING jack provides necessary connections for remote control of frequency, sweep width band selection, and the 0 to 20 dB vernier output level. This jack also provides connections for external amplitude and frequency modulation and external triggering of the sweep rate generator, as well as connections to internal DC voltages, and sweep and blanking signals.

## BAND SELECTION

Selection is accomplished via TTL signals or contact closure.

## FREQUENCY

May be remotely programmed within the selected band by applying a voltage between +10 V and -10 V (-10 V programs the low frequency end of band).

Tuning sensitivities are:

band 1	35.7 mV/MHz
band 2, 3	17.8 mV/MHz
band 4	7.1 mV/MHz

## SWEEP WIDTH

May be controlled with a remote potentiometer.

## VERNIER, 0-20 dB OUTPUT

May be controlled by setting the front-panel OUTPUT VERNIER for maximum output and applying a DC voltage between 0 and -4.5 V (-4.5 V programs 20 dB reduction in power). Front-panel METER will indicate the RF output level. Simultaneous AM and level control can be achieved by adding the appropriate DC offset to the modulating signal. See "External AM".

## EXTERNAL AM

Amplitude modulation can be accomplished according to the specifications below. Simultaneous AM and level control can be achieved by adding the appropriate DC offset to the modulating signal. See "Vernier 0-20 dB Output".

FREQUENCY RANGE	DC to 10 kHz (3 dB bandwidth)
SENSITIVITY	1 Vpp per 10% AM
MAXIMUM MODULATION %	Varies from 10% to 90% depending upon the setting of the OUTPUT VERNIER control as shown in Figure 2-16. Overmodulation will cause the front-panel UNLEVELED light to turn on; however, since the unleveled condition would exist only at the peak or trough of modulation, the light will be less than full intensity.

EXTERNAL FM

Any portion of any band not containing a band switching discontinuity point can be swept at any rate up to 10 kHz.  $\pm 50$  MHz deviation can be obtained at rates up to 50 kHz. Modulation rates up to 200 kHz are possible with reduced deviation and unspecified linearity. Tuning sensitivity is the same as that for remote frequency control.

### 1.2.7 GENERAL

OPERATING TEMPERATURE	0° to 50°C
POWER REQUIREMENTS	115 or 230 VAC $\pm 10\%$ , 50 to 400 Hz, approximately 25 VA.
DIMENSIONS	30.3 cm wide x 13.4 cm high x 34.9 cm long (12" x 5¼" x 13 ¾")
WEIGHT	10.5 kg (23 lbs.) net 12.7 kg (28 lbs.) shipping

### 1.3 OPTIONS

All options are factory or field installable. A maximum of 5 A1 or A2 options can be installed in the instrument in addition to 1 each of Options A3, B4, and B5.

A1	Single Frequency Marker at any frequency within the instrument range.
A2	Harmonic (comb) Marker at 1, 5, 10, 50, or 100 MHz intervals (other intervals available on special order). Also available is a Dual Harmonic Marker at 0.1/1 MHz intervals (occupies two marker sockets).
NOTE: Operating range of A2 options is 1 to 1500 MHz.	
A3	Deluxe Harmonic Marker at 1, 10, 50, and 100 MHz intervals over entire instrument range.
B4	Pen Lift provides contact closure during forward sweep trace. Binding post terminals are provided on rear panel.
B5	Auxilliary RF Output provides rear-panel RF output signal (approximately -10 dBm, depending on marker options installed) for driving a frequency counter or other similar purpose.

## 1.4 ACCESSORIES

### 1.4.1 FURNISHED WITH INSTRUMENT

INSTRUCTION MANUAL

PROGRAMMING PLUG

Connector and pins provided to mate with jack on instrument rear panel.

### 1.4.2 AVAILABLE AT EXTRA COST

WIDE BAND RF DETECTORS

Model D153. Frequency range: 1 MHz to 12.4 GHz.

RACK MOUNT KIT

K108 enables instrument to be mounted in a standard 19" wide instrument rack.

SERVICE KIT

K005 provides a module extender, extension cables and adaptor.

# SECTION 2

## OPERATION

### 2.1 INTRODUCTION

This section provides complete installation and operating instructions for the Wavetek Model 2002A. The instructions include information on mechanical installation, electrical installation, front-and-rear-panel features, operating procedures, and programming instructions.

### 2.2 MECHANICAL INSTALLATION

#### 2.2.1 INITIAL INSPECTION

After unpacking the instrument, visually inspect external parts for damage to knobs, connectors, surface areas, etc. The shipping container and packing material should be saved in case it is necessary to reship the unit.

#### 2.2.2 DAMAGE CLAIMS

If the instrument received has been damaged in transit, notify the carrier and either the nearest Wavetek area representative or the factory in Indiana. Retain the shipping carton and packing material for the carrier's inspection.

The local representative or the factory will immediately arrange for either replacement or repair of your instrument without waiting for damage claim settlements.

#### 2.2.3 RACK MOUNTING (K108)

CONTENTS (See Figure 2-1).

ITEM	QTY	PART NO.
A (Insert)	2 ea	1410-00-4650
B (Side)	2 ea	1410-00-5260
C (Screw)	8 ea	2810-17-8108
D (Screw)	4 ea	2810-17-8110

### PROCEDURE

Remove screws from one side panel. Mount items A and B against side panel of the instrument and secure with screws provided. Repeat for other side of unit. If rack mount kit is removed from unit, use screws originally in side panels to avoid possible internal damage.

### 2.3 ELECTRICAL INSTALLATION

#### 2.3.1 POWER REQUIREMENTS

This instrument operates from either 115 VAC or 230 VAC supply mains, as selected by the rear-panel AC LINE switch. Before operating this instrument, be sure that the AC LINE FUSE is the correct value for the selected voltage (see Section 2.5).

The Power Supply has been designed to operate over a 50 to 400 Hz line frequency; however, the line operated sweep rate function must be adjusted to the line frequency.

Instruments are shipped from the factory set up to operate at 115 VAC, 60 Hz unless otherwise specified.

#### 2.3.2 PERFORMANCE CHECKS

The electrical performance of this instrument should be verified prior to actual use. Performance checks for incoming inspection are given in Section 4 of this manual.

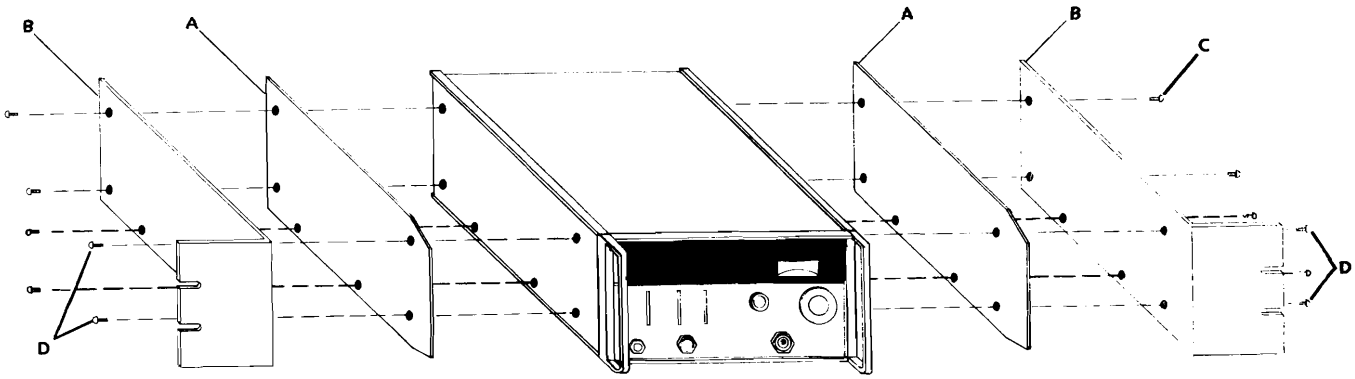

Figure 2-1. K108 Rack Mount

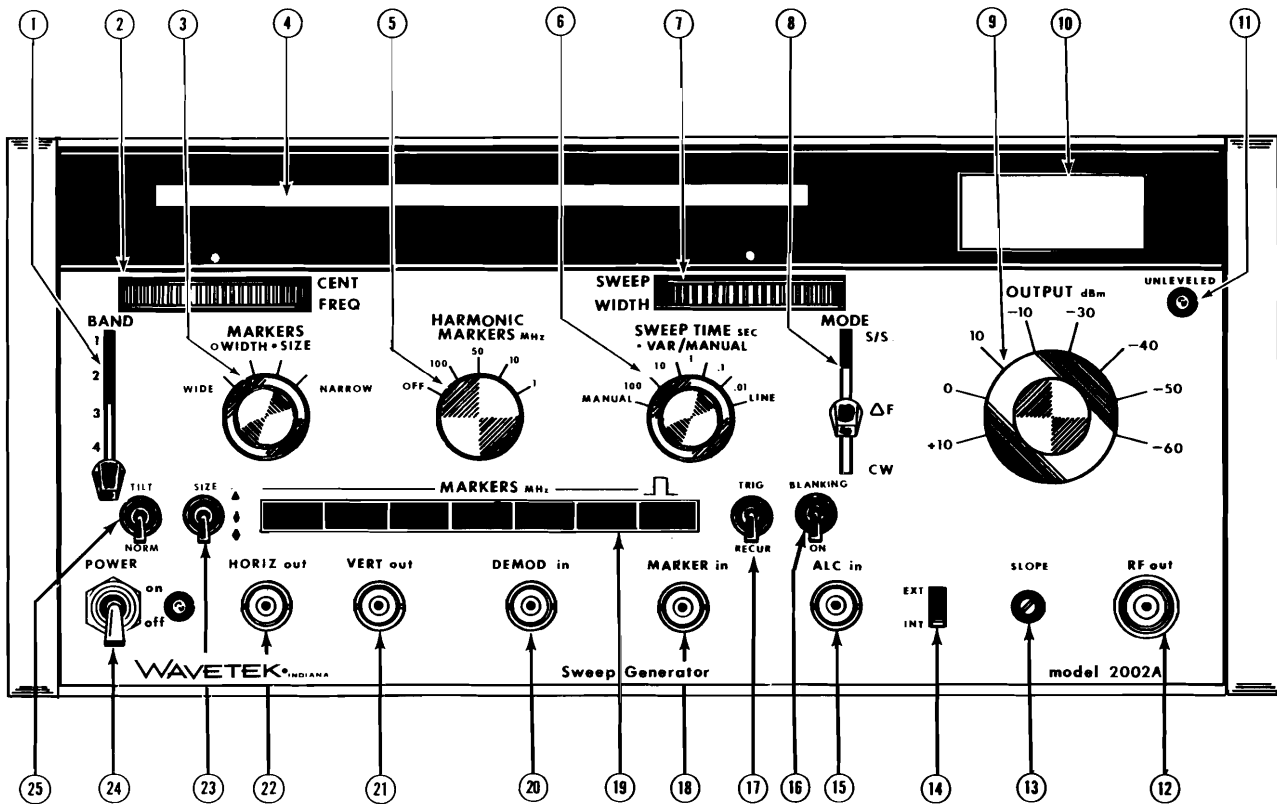

Figure 2-2. Front Panel

## 2.4 DESCRIPTION OF FRONT PANEL

Refer to Figure 2-2.

- (1) BAND switch selects desired frequency band.
- (2) CENTER FREQ/START thumbwheel controls center frequency when MODE switch is set to  $\Delta f$  or CW, and start frequency when MODE switch is set to S/S.
- (3) MARKER WIDTH, SIZE controls; outer ring selects marker width (4 positions); inner knob varies marker amplitude.
- (4) FREQUENCY SCALE shows center frequency and sweep width, or start/stop frequencies (depending on position of MODE switch). Graduated for all 4 bands.
- (5) HARMONIC MARKER switch selects markers generated by the Deluxe Harmonic Marker (Option A3). If this option is not installed, this knob has no function.
- (6) SWEEP TIME, VAR/MANUAL controls; outer ring selects sweep time range (4 ranges); line rate, or manual control; inner knob provides manual frequency sweeping with the outer ring set to MANUAL, and vernier control of the sweep time with the outer ring set to any of the 4 sweep time ranges.
- (7) SWEEP WIDTH/STOP thumbwheel controls sweep width when MODE switch is set to  $\Delta f$ , and stop frequency when MODE switch is set to S/S. When the MODE switch is set to CW, this control has no function.
- (8) MODE switch selects S/S (Start/Stop),  $\Delta f$ , or CW mode.
- (9) OUTPUT VERNIER, STEP ATTENUATOR; outer ring controls RF output over a 70 dB range (+10 to -60 dBm) in 10 dB steps; inner knob provides vernier control (+3 to -17 dB) of RF output.
- (10) METER indicates RF output over a 20 dB range (calibrated from +3 to -10 dB). The METER reading added algebraically to the STEP ATTENUATOR indication is the RF output of the instrument.
- (11) UNLEVELED lamp signals when the METER reading is not valid.
- (12) RF OUT connector (type N) provides connection for RF output signal.
- (13) SLOPE control provides compensation for frequency dependant level variations external to the instrument.
- (14) ALC switch closes the internal leveling loop when in the INT position. In the EXT position, an external monitor may be used to control the instrument's RF output (through the ALC IN connector). If the switch is in EXT, and no external monitor is used, the RF output is unleveled and the OUTPUT VERNIER has no effect.
- (15) ALC IN connector (type BNC) accepts an external leveling control signal from a remote monitor when the ALC switch is in the EXT position.
- (16) BLANKING switch allows the RF output to be blanked during sweep retrace when the switch is in the ON position. When the switch is not on, the RF output is displayed during retrace.
- (17) TRIG/RECUR switch selects either recurring sweep of the time selected by the SWEEP TIME control (with MODE switch in  $\Delta f$  or S/S), or triggered sweep, either manually or with an external source (the external trigger input is pin 7 of the rear-panel PROGRAMMING jack). Manual triggering is accomplished by pushing the TRIG/RECUR switch to its full up (momentary) position.
- (18) MARKER IN connector (type BNC) accepts an external CW signal to produce a marker at the external frequency on the display.
- (19) MARKER switches select which internal markers are active (marker frequency is engraved on pushbutton). The furthest right switch selects internal square wave modulation.
- (20) DEMOD IN connector (type BNC) accepts demodulated swept signal from device under test so that markers can be added (the combined signal is available at the VERT OUT connector).
- (21) VERT OUT connector (type BNC) provides vertical display signal (demodulated signal plus markers if DEMOD IN is used) for display oscilloscope.
- (22) HORIZ OUT connector (type BNC) provides a 0-10 V triangle wave for driving the display oscilloscope horizontal channel.
- (23) MARKER SIZE switch selects large ( $\sim 7$  mVpp to 3.5 Vpp) markers, small ( $\sim 0.2$  mVpp to  $\sim 20$  mVpp) markers, or rectified ( $\sim 0.2$  mV to 1.25 V) markers (the marker amplitude is varied by means of the MARKER SIZE control). The rectified markers are designed for use with X-Y recorders.
- (24) POWER switch applies AC power to the Power Supply. Pilot light indicates operation.

(25) TILT/NORM switch provides vertical markers in the NORM position, and horizontal markers of fixed amplitude (10% of horizontal display) in the TILT position when the MARKER SIZE control is set to minimum. Increasing the setting of the MARKER SIZE control will cause the horizontal markers to tilt toward a vertical position. This feature is helpful in identifying frequencies on steep response curves.

## 2.5 DESCRIPTION OF REAR PANEL

Refer to Figure 2-3.

(1) AUX RF OUT connector (type BNC, Option B5) provides approximately -10 dBm RF output.

(2) BLANKING output connector (type BNC) provides pulse for oscilloscope intensity input to remove band stacking transition points from scope display. Switch selects pulse polarity.

(3) SWEEP DWELL switch selects normal or delayed (approximately 4 msec) sweep.

(4) AC LINE cord provides connection to AC mains via 3 prong plug.

(5) AC LINE switch enables unit to operate from either 115 VAC or 230 VAC supply mains.

(6) AC LINE FUSE is time delay; 1.0 amp for 115 VAC operation, 0.5 amp for 230 VAC operation.

(7) PEN LIFT (Option B4) binding posts provide contact closure during forward sweep when the front-panel SWEEP TIME control is in the 1-10 sec, 10-100 sec, or MANUAL range. In all other ranges, and during retrace, the contacts are open. NOTE: In MANUAL sweep, there is no retrace signal, so the contacts are continually closed.

(8) PROGRAMMING PLUG provides input connections for external trigger, sweep delay, external AM/FM, and remote control of center frequency, sweep width, band selection and RF output. Output connections are provided for sweep ramp, retrace blanking, and Power Supply voltages.

### NOTE

If Options B4, B5 are not installed, blank plug buttons will be installed in the rear panel instead of the indicated connectors.

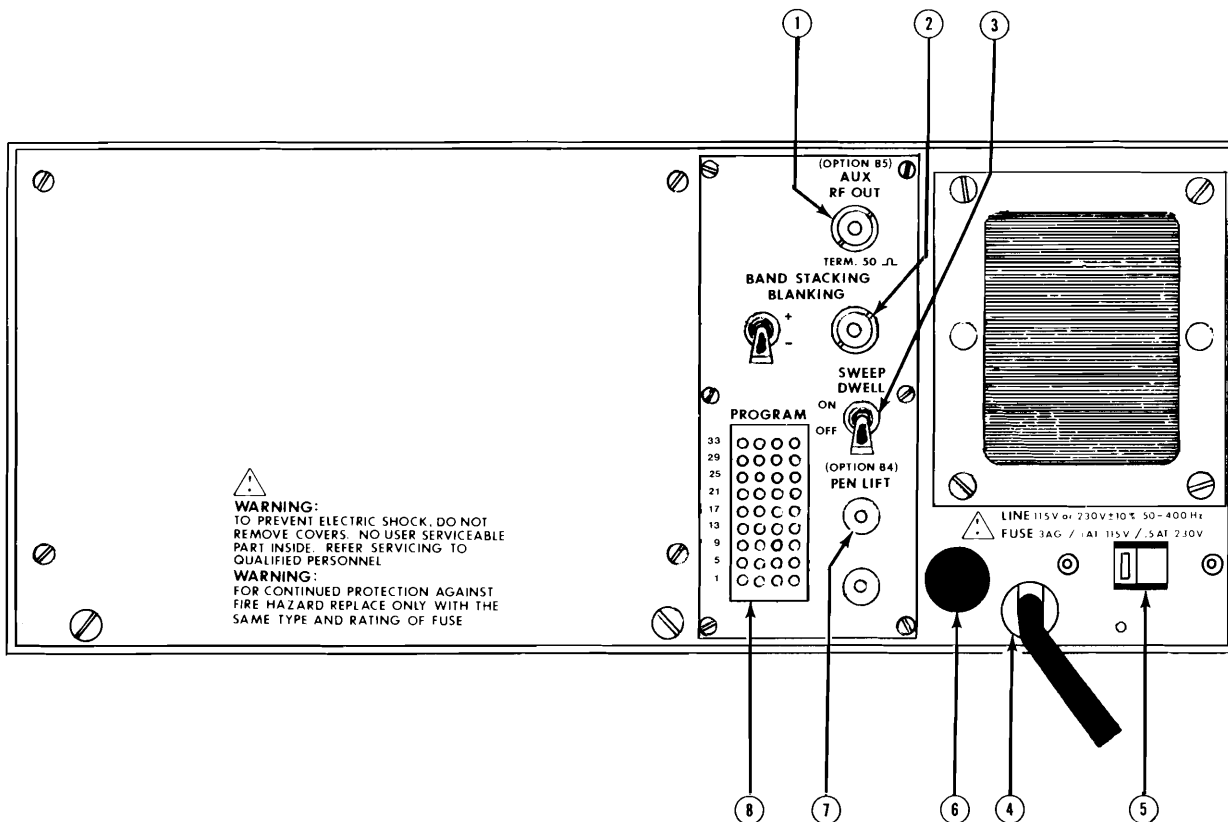

Figure 2-3. Rear Panel



## 2.6 TYPICAL OPERATING SET-UP

When initially setting up the instrument, first check the rear-panel AC LINE FUSE and switch to be sure the instrument is set for operation with the available AC mains.

Make connections between the instrument, the device under test, and the oscilloscope as shown in Figure 2-4. Since hum, RF leakage, and spurious signal pick-up must be kept to a minimum, it is essential that good connections and grounds be maintained throughout the entire set-up. Use coaxial cables with BNC connectors wherever possible. The RF output cable is especially critical. It should have a characteristic impedance of 50 ohms, and should be kept as short as practical (under 3 feet). If the input impedance of the device under test is not 50 ohms, a matching network, as shown in Figure 2-4, should be used to ensure a constant amplitude input signal to the device under test.

After the RF signal passes through the RF circuit of the device under test, it must be demodulated before being connected to the DEMOD IN of the instrument. If a demodulator is not a part of the device under test, one must be added externally (see Figure 2-4). The input impedance of the demodulator must present the proper load to the RF circuit being tested. The Wavetek Model D153 RF Detector is recommended for 50 ohm applications.

Turn the front-panel POWER switch on. The pilot light should indicate an operating condition.

### NOTE

**This instrument does not require a warmup period unless it is to be used at the extreme limits of its specifications.**

After completing the set-up, adjust the instrument front-panel controls for the required center frequency, sweep width, output amplitude, and sweep rate. Turn the desired markers on and adjust their size and width.

## 2.7 SPECIAL OPERATING NOTES

### 2.7.1 ERRORS FROM SWEEP RATE EFFECTS

When sweeping RF circuits having rapid amplitude changes, errors may occur, due mainly to detector delays. Decreasing the detector output time constant will minimize this effect. Figure 2-5 illustrates sweep rate effect.

To check for sweep rate effect, first set the sweep width to its lowest practical setting, then reduce sweep time while closely observing the swept output response. Any change in the response indicates the sweep rate is too fast for a true response. When a further reduction of sweep time

does not change the response, a true response has been obtained.

### 2.7.2 EFFECTS FROM OVERLOADING

The use of excessive signal from the instrument can overload the receiver circuits. To assure that this condition is not present, and that the response is a true representation of the device under test, turn the OUTPUT STEP and VERNIER controls to minimum output amplitude. Gradually increase the output amplitude until a response is obtained. Further increasing the output amplitude should not change the configuration of the response envelope does change, such as flattening at the top, decrease the output just far enough to restore the proper configuration.

### 2.7.3 MAKING MEASUREMENTS AT LOW LEVEL

When making measurements at low levels, radiation and ground loops become problems. Using double shielded cables for cables carrying RF signals helps minimize the radiation problem. Ground loops causing hum pick-up can sometimes be eliminated by completing only one ground connection between each instrument. This applies particularly to the scope horizontal input. If the ground connection is made at the vertical input terminal, an additional ground at the horizontal input terminal will often result in hum pick-up.

### 2.7.4 SWEEP DWELL

In order to stabilize external circuits (such as when using a network analyzer), it is sometimes desirable to turn the RF signal on prior to the start of the sweep. This can be accomplished using the rear-panel SWEEP DWELL switch. When the switch is turned on, the RF output is tuned on approximately 4 msec before the sweep begins.

### NOTE

**This applies only to the four variable time positions of the SWEEP TIME control, and does not apply to either the LINE or MANUAL position.**

### 2.7.5 OPERATION WITH X-Y PLOTTERS

Two features are incorporated into the instrument to facilitate operation with X-Y plotters.

First, a marker clamp switch (part of the front-panel MARKER SIZE switch) which converts the high frequency marker signals to lower frequencies, compatible with the operating speed of the marker pen.

The second feature (Pen Lift) is available as Option B4, and is described in Section 2.8.4.

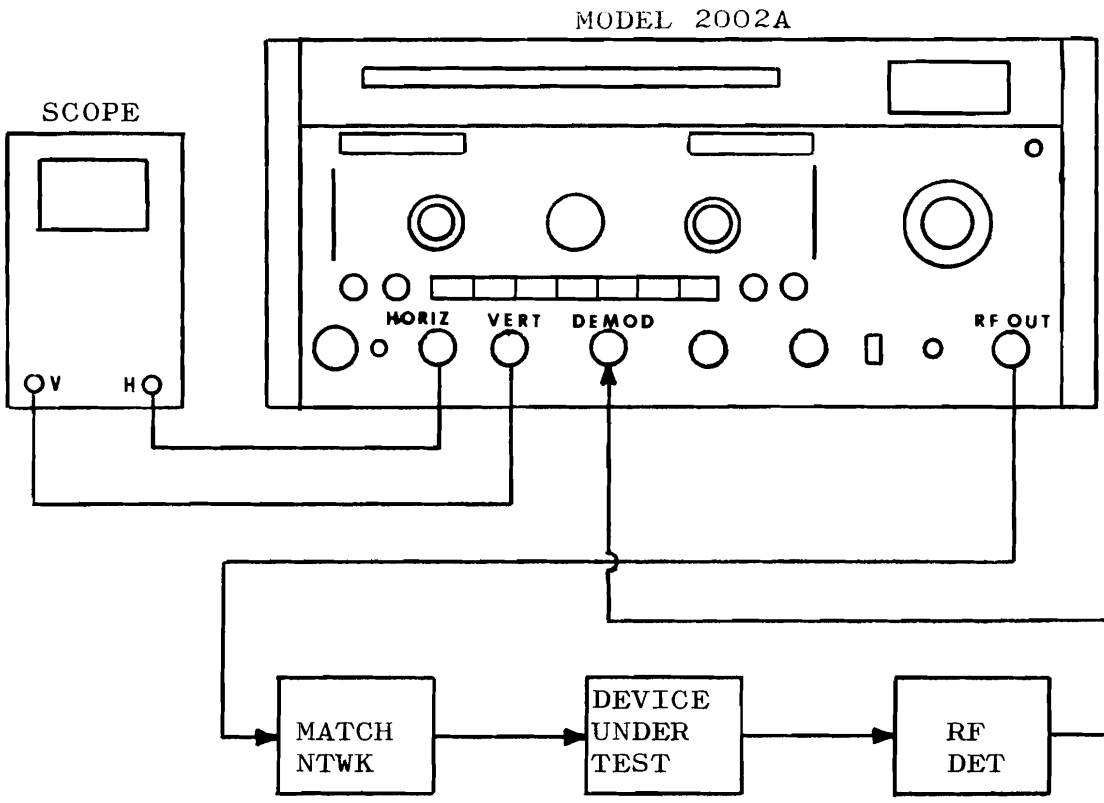

Figure 2-4. Typical Test Set-up

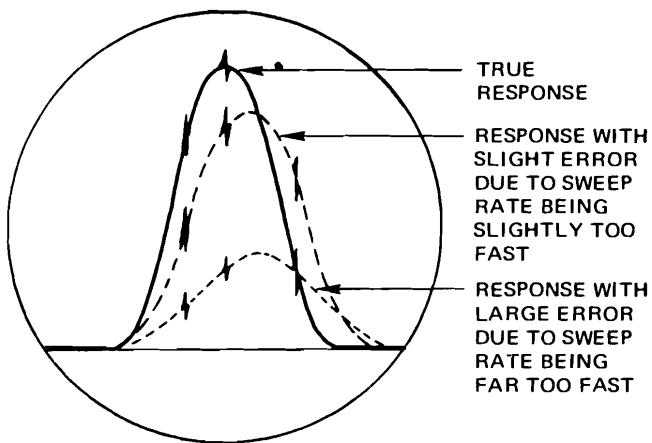

Figure 2-5. Sweep Rate Effects

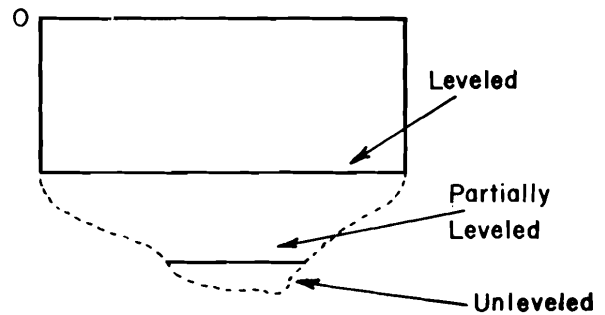

Figure 2-6. External Monitor Output Signal

## 2.7.6 OPERATION WITH EXTERNAL MONITOR

Operation with an external monitor can produce a flatter (less amplitude variation) input signal to the device under test than is obtainable with the internal monitor, since the monitor point is located at the point where greatest flatness is desired and is not affected by cable VSWR or input impedance of the device under test. Another application is to level at the output point of a wide band power amplifier in order to increase the output power capability of the sweep generator.

To operate with an external monitor, first set the OUTPUT STEP and VERNIER controls for maximum (+13 dBm). Next, connect the output from the external monitor to the front-panel ALC IN connector and set the ALC switch to the EXT position. The signal from the external monitor must be of negative polarity between 0.2 and 2 volts. If the signal is larger than 2 volts, use a resistive divider to obtain the less-than-2 volts signal. While observing the output from the monitor on an oscilloscope, adjust the OUTPUT VERNIER until the monitor signal becomes leveled (refer to Figure 2-6).

### NOTE

**If the requirement of a 0.2 to 2 V monitor signal results in overloading of the device under test, insert an external attenuator pad between the monitor and the device under test.**

## 2.7.7 SLOPE

Up to  $\pm 1$  dB/GHz amplitude slope may be introduced to compensate for frequency-dependant variables in the test system external to the instrument. The pivot point for the slope is 1 MHz, with the maximum amplitude change due to slope introduction being  $\pm 2.5$  dB at 2500 MHz (refer to Figure 2-7).

When the front-panel SLOPE control is set to its mid-position adjustment (0 slope), an uncorrected signal will be displayed.

## 2.7.8 1 KHz MODULATION

This feature provides 1 kHz square wave modulation of the RF output signal. On/off control is provided by a push button switch on the instrument's front panel. The 1 kHz modulating frequency may be adjusted using the control located on top of module M121 (see Figure 5-22).

## 2.7.9 PEN LIFT (OPTION B4)

This option provides a contact closure during forward sweep time. During retrace, the contacts are open. This option can be used to operate the pen lift of an X-Y plotter. It is active only during the two slowest settings of the SWEEP TIME switch (1 to 10 seconds and 10 to 100 seconds) and during manual sweep. (During manual sweep the contacts are always closed.) The connections for Option B4 are two binding posts on the instrument rear panel.

## 2.7.10 AUX RF OUT (OPTION B5)

This option provides an RF signal at approximately -10 dBm through a rear-panel connector. This signal is identical in frequency and sweep characteristics to the signal from the front-panel RF OUT connector; however, there is no provision for controlling the level of the auxiliary signal. (The actual output level of the auxiliary signal is dependent on the number of marker options (A1, A2, A3) installed in the instrument. The more marker options, the lower the output level.) Likewise, the auxiliary signal will show FM, but will not show AM.

### NOTE

**For proper marker operation, the AUX RF OUT connector must be either connected to a 50 ohm device, or terminated in 50 ohms (terminator provided).**

## 2.8 PROGRAMMING

### 2.8.1 INTRODUCTION

Connections for remote control of output level, center frequency, sweep width, band selection, and sweep triggering, and also external AM and FM are provided in the rear-panel PROGRAMMING jack. The jack and its pin functions are detailed below (refer to Figure 2-8).

### 2.8.2 OUTPUT PINS

The first group of pins are voltage and signal outputs. Pin 1 is a common ground. Pins 2 and 3 provide  $\pm 10$  V, used for remote frequency tuning. Pins 4 and 5 are the  $\pm 18$  V main regulated supplies, and can be used in external applications which draw less than 50 mA each.

Pin 8 is the sweep ramp with varies over a  $\pm 10$  V range. This signal is similar to the signal from the front-panel HORIZ OUT connector, except that the latter ranges from 0 V to +10 V. These ramps are independent of frequency and sweep width.

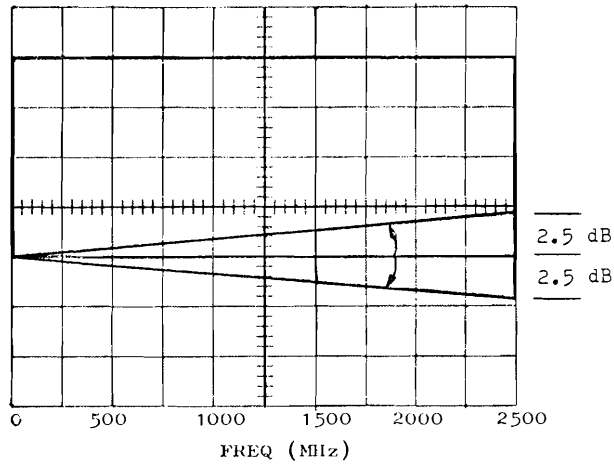

Figure 2-7. Slope

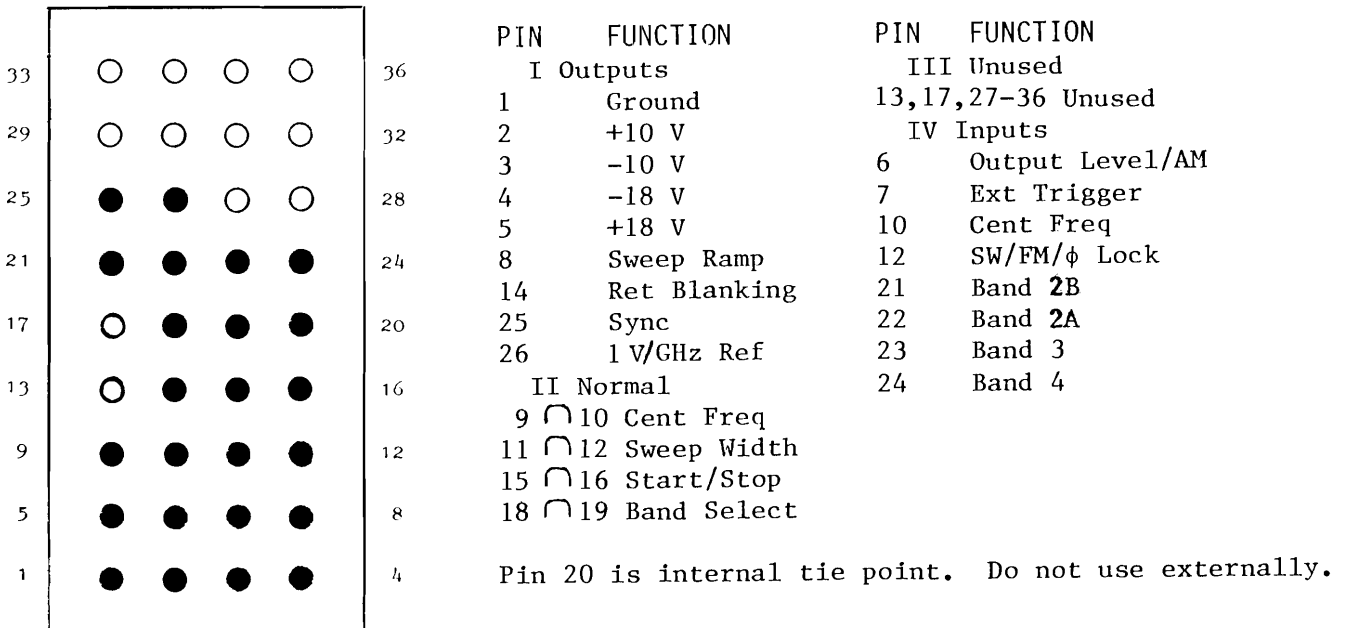

Figure 2-8. PROGRAMMING Plug Pin Configuration

Pin 14 provides a retrace blanking signal for a display oscilloscope. The levels at this connector are +16 V (RF off) and -16 V (RF on).

Pin 25 provides a TTL "high" signal whenever the RF output frequency crosses a band switching discontinuity point (500, 1000, 1500 MHz). At all other times, the output is TTL "low". This signal finds use in working with network analyzers.

Pin 26 is a 1 V/GHz reference which provides an indication of the instantaneous RF output frequency. If the RF output frequency is 1200 MHz, pin 26 will be +1.2 V. If the RF output is swept from 1600 to 2400 MHz, the voltage at pin 26 will follow the frequency, producing a +1.6 V to +2.4 V ramp.

### 2.8.3 NORMAL OPERATION PINS

The second group of pins is used to provide normal front-panel operation of the instrument. Pin 9 is jumpered to pin 10, pin 11 is jumpered to pin 12, pin 15 is jumpered to pin 16, and pin 18 is jumpered to pin 19. A plug containing these jumpers must be installed on the rear-panel PROGRAMMING jack in order to accomplish normal operation.

### 2.8.4 UNUSED PINS

The third group of pins is unused.

### 2.8.5 INPUT PINS

The functions of the last group of pins are as follows:

#### REMOTE FREQUENCY CONTROL (PIN 10)

Normal front-panel control of center frequency is provided by a jumper wire between pins 9 and 10 of the rear-panel PROGRAMMING plug. To remotely control the center frequency, remove the jumper and connect pin 10 to the external control, as shown in Figure 2-9.

#### REMOTE SWEEP WIDTH CONTROL (PIN 12)

Normal control of sweep width is provided by a jumper between pins 11 and 12 of the rear-panel PROGRAMMING plug. To remotely control the sweep width, remove the jumper and connect pin 12 to the external control, as shown in Figure 2-10.

#### NOTE

**When using the instrument with remote control of sweep width, external FM, or in phase lock operation, the front-panel MODE switch must be set to  $\Delta f$ .**

#### EXTERNAL FM (PIN 12)

For FM, remove the pin 11 to 12 jumper and connect the modulating source as shown in Figure 2-11.

The FM signal should have an average potential of 0 V. Frequency sensitivity is 35.7 mV/MHz for band 1, 17.8 mV/MHz for bands 2 and 3, and 7.1 mV/MHz for band 4. Maximum frequency deviation as a function of modulating frequency is shown in Figure 2-12.

The peak amplitude of the modulating signal plus the DC voltage applied to pin 10 of the PROGRAMMING jack should not exceed  $\pm 10$  V, since a greater voltage would cause the instrument to sweep beyond its band limits.

#### PHASE LOCK (PIN 12)

When the instrument is operated in a closed-loop synchronizing system, the correction voltage is applied to pin 12 of the PROGRAMMING jack. Again, the MODE switch must be set to  $\Delta f$  and the pin 11 to 12 jumper must be removed (refer to Figure 2-13).

#### REMOTE OUTPUT LEVEL (PIN 6)

For remote control of the 0 to 20 dB OUTPUT VERNIER control range, first adjust the front-panel OUTPUT VERNIER control fully clockwise. This will produce a METER reading of 3. Connect the external level control as shown in Figure 2-14. The program level will be indicated on the front-panel METER.

#### EXTERNAL AM (PIN 6)

To produce AM, connect the modulating source to pin 6, as shown in Figure 2-15.

The modulating frequency may vary over a 0 to 10 kHz (at 3 dB point) range. The modulation sensitivity is 1 V<sub>pp</sub>/10% modulation. The maximum % AM is dependent upon the front-panel OUTPUT VERNIER setting, as shown in Figure 2-16.

#### EXTERNAL TRIGGER (PIN 7)

The Sweep Time circuit may be remotely triggered by applying a +10 V pulse to pin 7 of the rear-panel PROGRAMMING plug. For proper operation, the front-panel SWEEP TIME control must be set to one of the four variable time positions, and not to MANUAL or LINE. The TRIG/RECUR switch must be set to TRIG. The repetition rate of the external trigger should be slower than the frequency repetition rate set by the front-panel SWEEP TIME and VAR/MANUAL controls.

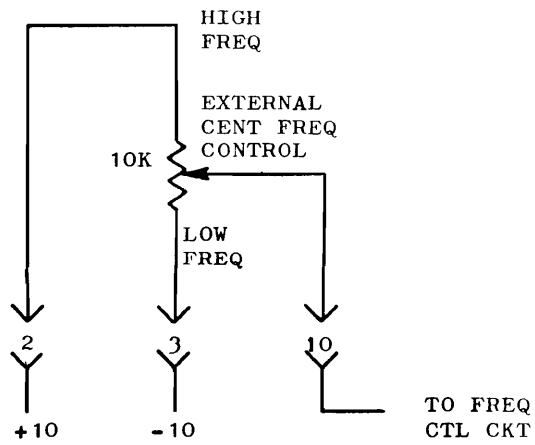

Figure 2-9. Remote Center Frequency Control

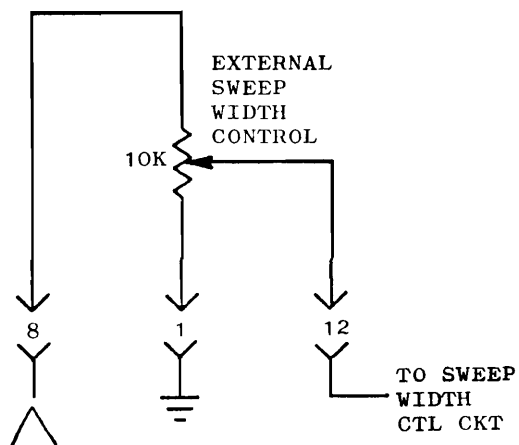

Figure 2-10. Remote Sweep Width Control

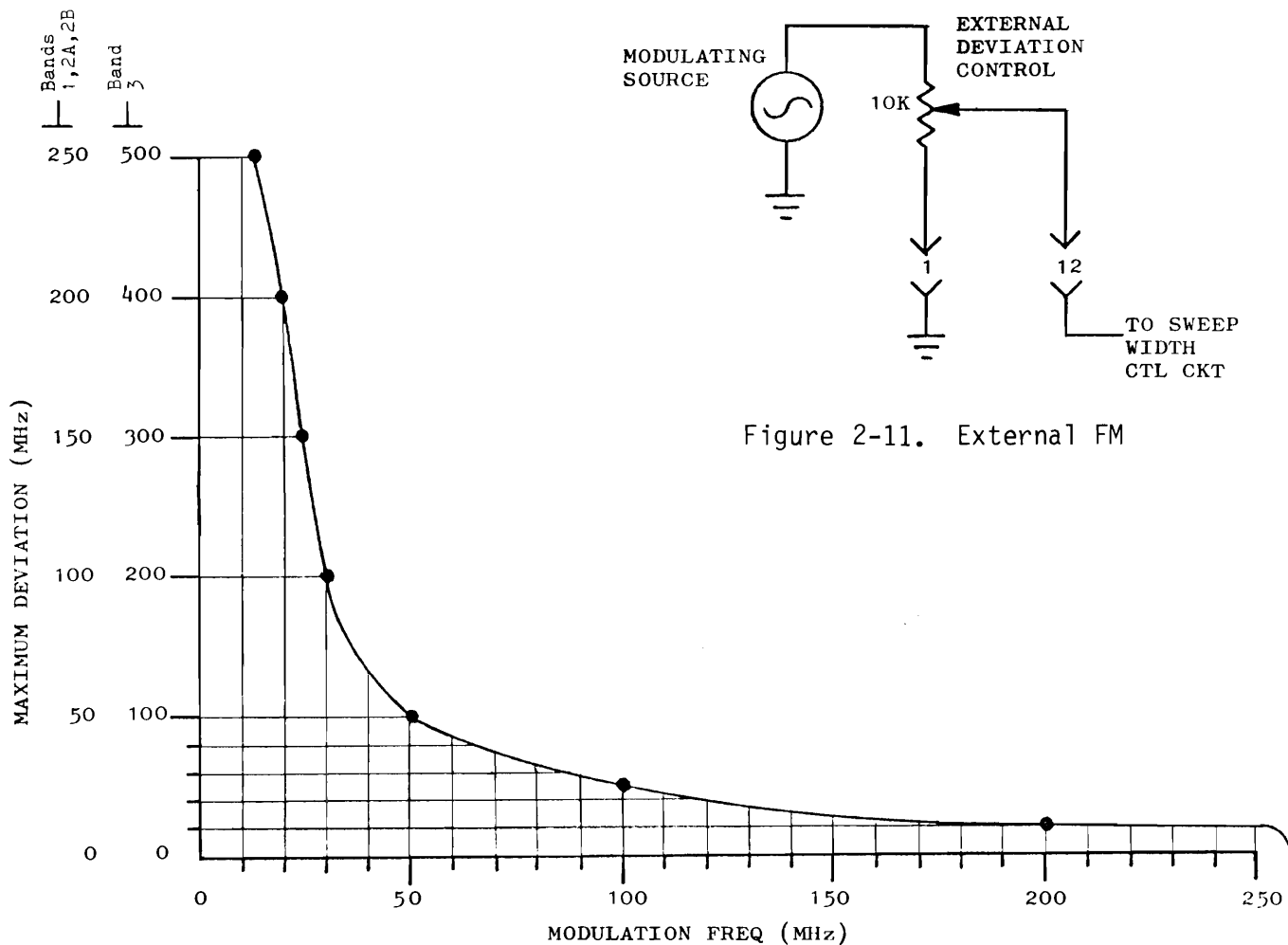

Figure 2-12. Maximum FM Deviation

REMOTE BAND SELECTION (PINS 21-24)

For remote control of band selection, remove the jumper between pins 18 and 19 on the PROGRAMMING plug. Any frequency band may now be selected by applying a ground (contact closure or TTL) signal to pin 21, 23, or 24 on the PROGRAMMING plug. Applying a ground signal to pins 21 and 22 simultaneously will select the second half of band 2 (1000-1500 MHz) (see Section 3.13). If no ground signal is applied, band 1 will be selected.

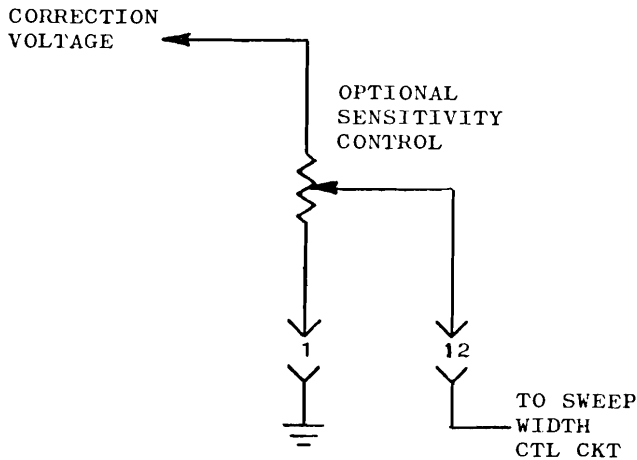

Figure 2-13. Phase Lock

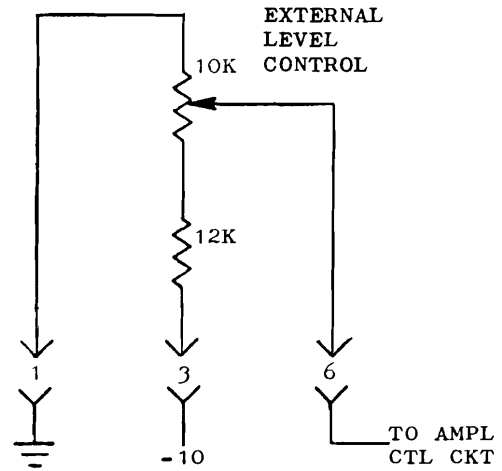

Figure 2-14. Remote Level Control

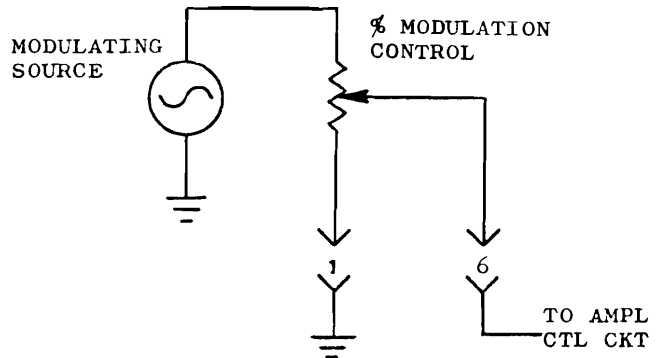

Figure 2-15. External AM

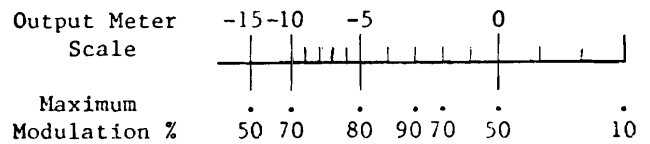

Figure 2-16. Maximum % AM

# SECTION 3

## THEORY OF OPERATION

### 3.1 INTRODUCTION

This section first presents an overall block diagram view of the Model 2002A, followed by a more detailed description of each module and assembly.

Before beginning the actual circuit descriptions, it would be well to become familiar with the mechanical arrangement of the instrument. This will enable the block diagram and circuit descriptions to be associated with the physical locations in the instrument, providing a better overall understanding of the instrument (refer to Figure 5-22).

### 3.2 BLOCK DIAGRAM

The block diagram in Figure 3-1 contains both block and module information. The blocks contained within each module are indicated by the module outline.

The general operation of the Model 2002A is as follows:

The front-panel CENT FREQ and SWEEP WIDTH control settings are fed into the M102A and M103A Sweep Drive modules, where they are combined into a single signal. This signal (sweep drive) is used to drive the varactor diodes in the appropriate Sweep Oscillator (M109 or M110). Necessary level shifting, shaping, and amplitude control are accomplished in the Sweep Drive modules.

The Sweep Oscillator output is fed into the MA111 Wide Band Amplifier, and then through the Step Attenuator to the RF output. Leveling is accomplished by a monitor diode in the MA111 which compares the output level to a reference voltage supplied by the OUTPUT VERNIER. Any error is amplified in the M104A Leveler module, and correction is made at the PIN diode leveler in the MA111.

The marker circuit is composed of the M105 Marker Adder module, the M6C External Marker module, and the various marker options selected by the customer. The marker circuit uses a sample of the RF signal (sweep sample) which is also leveled in the M104A Leveler. This leveling not only provides a constant-amplitude sweep sample signal to the marker circuit, but also standardizes the sweep sample signals in all instruments, assuring proper operation of field installed marker options.

More detailed descriptions of the individual modules and assemblies are provided below. Schematics are in Section 7.

### 3.3 DPS2A – POWER SUPPLY

The Power Supply provides DC power for the rest of the instrument, and a 27 VAC signal to the M101B Sweep Rate Generator module.

The transformer steps the line voltage down to 27 VAC, a level which can be used by the DC-producing circuits. (A portion of this 27 VAC signal is sent to the M101B for use in the line rate sweep function of the instrument.) Fullwave rectifiers and filter capacitors convert the AC signal to DC.

A portion of this 27 VDC signal is sent to the +20 V regulator mounted on the instrument chassis, the rest is sent to the  $\pm 18$  V and +7 V supply circuits.

The +18 V circuit has a temperature-compensated precision voltage reference. This reference is compared to the output voltage by an error amplifier which corrects any error in the output voltage.

The -18 V circuit compares the +18 V and -18 V outputs and holds the difference in their magnitudes to zero.

The +7.3 V circuit uses a three-terminal adjustable voltage regulator IC to provide a pre-regulated +7.3 V output. This voltage supplies other voltage regulators throughout the instrument.

### 3.4 M101B – SWEEP RATE

#### INTRODUCTION

This module generates the basic sweep ramp for the instrument, an inverted ramp used in S/S mode, and a synchronous square wave used for blanking.

The M101B is basically a hysteresis oscillator, consisting of a hysteresis switch (IC5A) and an inverting integrator (IC1 with C9). The sweep ramp is the integrator output, while the inverted ramp (derived from the sweep ramp) is the output of an inverting buffer (IC2).



## SWEEP RAMP

Diodes CR17 and CR18 clip the hysteresis switch output to produce a  $\sim\pm 10.6$  V square wave. CR13 and CR14 reduce the level to  $\sim\pm 10$  V, and also provide temperature compensation. The  $\pm 10$  V square wave is positively fed back to the non-inverting input of the hysteresis switch along with delayed negative feedback from the integrator.

When the negative feedback outweighs the positive feedback, the non-inverting input crosses the ground reference on the inverting input and the switch changes state. This occurs when the hysteresis switch output and the sweep ramp are equal in magnitude but opposite in polarity. The switch output is buffered by IC6B and sent through the sweep time resistor network to pin 10 of the module, the inverting integrator input.

## SWEEP TIME

Sweep time is the time required for the sweep ramp to rise from -10 V to +10 V, and is determined by the current fed into the inverting integrator input. Sweep time is selected by the front-panel SWEEP TIME control, and is calibrated by the Freq. Adj. control (R60).

## TRIGGERED SWEEP

For operation in recurring sweep mode, +18 V is applied to pin 2 of the module. For triggered sweep mode, this voltage is removed, shutting off Q2 and removing the reverse bias on CR12. This lowers the hysteresis switch trip point to -10.7 V and arms the clamping circuit (IC3A, Q1, and associated components). As the descending ramp reaches -10 V, Q1 fires and clamps the ramp at -10 V. Since the ramp cannot reach -10.7 V, recurring sweep is prevented.

The trigger circuit (IC3B and associated components) is armed when clamping has occurred. The positive trigger pulse is applied (either from the front-panel switch or the rear-panel PROGRAMMING plug) to module pin 5, and is fed through C11 to IC3B pin 5. This switches IC3B pin 7 to +18 V. As pin 5 drops back below the slightly positive voltage on pin 6, pin 7 switches to -18 V, sending a negative pulse to the hysteresis switch, causing it to switch states and trigger the sweep.

## LINE RATE SWEEP

Line rate sweep is an automatically triggered mode, the trigger source being a 27 VAC signal from the Power Supply. Pin 9 of the module is the line rate enable. When a +18 V signal is present, the reverse bias on CR10 is removed, and the 27 VAC is sent to IC3B as the trigger signal.

## SWEEP DWELL

A sweep dwell feature is also provided for use with network analyzers. The dwell is similar to the clamp described above, but differs in that it is produced at the start of the forward trace (hysteresis switch negative, RF output available), while the clamp occurs at the end of the retrace (hysteresis switch positive, RF output blanked). When a positive voltage is applied to pin 15 of the module, the bias on pin 6 of IC5B is made less negative. When the hysteresis switch output goes negative, a large negative spike is sent to IC5B pin 5, turning off Q3. The RF blanking is removed at this time by IC6A. With Q3 turned off, module pin 12 is pulled to ground, shutting off the inverting integrator. As pin 5 of IC5B returns to ground potential, it crosses the reference still on pin 6, thus turning on Q3 and starting the integrator.

## MANUAL SWEEP

During manual sweep, +18 V is applied to pin 1 of the module, which places  $\sim 2.5$  V bias on pin 2 of the hysteresis switch and locks the switch negative. CR1 and CR3 are forward biased, so that IC1 is now a linear amplifier instead of an integrator. Manual Limit control R20 is adjusted such that the front-panel VAR/MANUAL control varies the output of IC1 between -10 V and +10 V; thus, the ramp can be manually swept by means of the VAR/MANUAL control.

## 3.5 M102A – SWEEP DRIVE

This module provides the correct sweep drive voltage required by sweep oscillators 1 and 3.

The M102A sums the voltage from the CENT FREQ control with a portion of the sweep ramp selected by the SWEEP WIDTH control setting. The combined ramp is then shaped into the proper signal to drive the oscillators. The unshaped ramp and two offset ( $\sim\pm 7.5$  V) ramps appear as outputs from the M102A to the M103A, where they are used in shaping the sweep drive signals for oscillators 2A and 2B.

The shaping of the sweep drive signals is accomplished by adding the two offset ramps to the combined ramp via 2.2 kohm resistor networks. As the ramp rises and falls, diodes strung along the networks are successively forward biased at  $\sim 2$  V intervals. As a result, the current to the input of the sweep drive IC is changed as each diode becomes forward biased, thus changing the effective input impedance to the IC, and so changing its gain. An increase in gain will cause an expansion of the sweep oscillator range.

Some of the diodes also feed current to an inverting amplifier, which, in turn, feeds its output to the sweep drive IC.

The effect of this inversion is to subtract current from the sweep drive IC, thus decreasing its gain and compressing the sweep oscillator range.

The actual amount of gain at each interval is determined by a potentiometer (Lin control) in series with each of the diodes. In this way, the sweep drive is shaped to produce a linearly swept RF output signal.

### 3.6 M103A – SWEEP DRIVE

This module supplies the centering voltages to the four voltage-controlled sweep oscillators in the instrument, and also provides the correct sweep drive voltages required for oscillators 2A and 2B.

The centering voltages are adjusted with potentiometers R7, R8, R9, and R10. These voltages are applied as bias voltages to the varactor diodes in each sweep oscillator. The bias is adjusted such that each sweep oscillator will be at its center frequency when its sweep drive voltage is zero.

The sweep drive circuitry in the M103A is very similar to that in the M102A described above. The combined and offset ramps from the M102A are added in 2.2 kohm resistor networks, turning on the shaping diodes in succession and effectively changing the input impedance and gain of the sweep drive IC's. Instead of an inverting amplifier, however, some of the diodes feed the non-inverting input of the sweep drive IC's, causing compression of the sweep oscillator range. The other diodes feed the inverting input of the sweep drive IC's, causing the sweep oscillator range to expand. As in the M102A, the Lin controls determine the amount of compression or expansion, and so enable a linearly swept RF output signal to be produced.

### 3.7 M104A – LEVELER

#### INTRODUCTION

This module contains the leveling circuitry for both the instrument RF output and internal sweep sample, and also drives the front-panel METER and UNLEVELED lamp.

#### SWEEP SAMPLE LEVELING

To level the sweep sample, a reference voltage is set on pin 6 of IC2B via level control R2. Pin 5 is the input from the MA111 sweep sample monitor diode. The output from the IC is used to drive a pair of PIN diode attenuators in the MA111, thus leveling the sweep sample.

#### RF OUTPUT LEVELING

The OUTPUT VERNIER voltage is buffered by IC1B. The

Level Max control (R12) calibrates the leveler when the VERNIER is fully cw. The output from this control is fed through a temperature compensation diode in the MA111 back to the M104A to be used as part of the RF leveler reference. The Level Min control (R23) calibrates the leveler when the VERNIER is fully ccw.

IC3 is the RF leveler. The composite voltage from R23 and R12 is used as a reference on pin 2. The output from the MA111 RF output monitor diode is applied to pin 3. The IC output, buffered by Q6, drives a PIN diode attenuator in the MA111, thus leveling the RF output.

#### METER DRIVE

The OUTPUT VERNIER signal is buffered by IC2A, and is used to drive the output METER. The METER reading is calibrated with the Meter Cal control, R18.

#### UNLEVELED LAMP DRIVE

Q2, Q3, and Q4 form a window detector, and turn on the front-panel UNLEVELED lamp when the leveler output exceeds its normal range.

### 3.8 M105 – MARKER ADDER

The function of this module is to take the small beat-frequency marker signals from the various marker options, amplify them, and send them to the front-panel MARKER SIZE control to be added to the demodulated RF signal for display.

Two parallel amplifiers are used in this module. The output of one of the amplifiers is adjusted with the Size Ratio control, R29, to produce markers of different sizes.

Transistors Q1 through Q5 are low-noise preamplifiers. Q9, Q10, Q12, Q13, Q22, and Q23 are controlled by the front-panel MARKER WIDTH switch. When selected, these FETs switch in capacitors to limit the frequency response of the amplifiers, thus producing narrow markers. With the MARKER WIDTH switch in either of its two narrowest settings, Q6 and Q8 are activated, switching in C29 and C8 on the emitters of the preamplifiers, thus increasing the low frequency gain and producing a narrowed center frequency null for the narrowed marker. IC1 and IC2, along with output transistors Q14, Q15, Q16, and Q17, produce the high gain needed for the marker output.

### 3.9 M109 – SWEEP OSCILLATOR 1

This module generates the 1-530 MHz band 1 (plus oversweep) frequency by heterodyning the output of an 1198 MHz fixed oscillator (Q5) and an 1199-1728 VCO (Q2). The VCO is biased to oscillate at 1448 MHz when the sweep drive signal is 0 V, and varies above and below this

frequency as the sweep drive is varied.) Both outputs are buffered and leveled before being heterodyned in the mixer (CR101 through CR104). The mixer IF output is preamplified (Q201 through Q204) and sent through the M110 to the MA111 Output Amplifier.

During blanking, Q4 turns on, turning off Q202 and Q203, thus eliminating the RF output signal.

Both oscillators are turned on by a -18 V signal from the M131 Band Select module. This signal also turns on IC2 which activates the sweep filter (CR202 and L205). This filter is controlled by the same sweep drive signal which controls the VCO, and serves to reduce the harmonic content of the preamplified output.

In CW mode, the sweep drive signal becomes a DC voltage, and -18 V is applied to pin 16 of the module, turning on Q1. This switches C6 to ground, thus reducing noise on the sweep drive signal and lowering the residual FM of the RF output signal.

### 3.10 M110 – SWEEP OSCILLATORS 2A, 2B, AND 3

This module generates the 500 to 2500 MHz output frequencies. The M110 consists mainly of three separate VCOs. The VCOs are turned on individually by -18 V signals from the M131 Band Select module. Each VCO is biased to oscillate at its respective band center frequency when its sweep drive signal is 0 V. As the sweep drive signal varies, so does the frequency of the selected VCO. A PIN diode switch at the output of each VCO couples the output signal to the module output, J2, and also serves to isolate the VCO from the other two VCOs. From J2, the output signal is sent to the MA111 Output Amplifier.

When band 1 is selected, the B-1 signal turns on the PIN diode switch formed by CR8 and CR9, routing the M109 output through to J2.

During CW operation, the sweep drive signals are DC voltages. FET switches Q3, Q4, and Q6 are activated, switching capacitors C32, C35, and C47 to ground. This reduces the noise on the sweep drive signals, and so reduces the instrument's residual FM.

In oscillators 2A and 2B, RF blanking is accomplished by turning the VCO off. Oscillator 3, having a slower on/off response, is left on during blanking, and the output is turned off via the PIN diode switch formed by CR18, CR19, CR24, and CR25.

### 3.11 MA111 – OUTPUT AMPLIFIER

The MA111 is a six-stage amplifier arranged in two sections of three stages each, the output of each section being individually monitored and leveled. The output of the first

section feeds the input to the second section, and also supplies a sweep sample output to the marker modules.

The collector voltage and the base current of each transistor stage is individually adjusted at the factory by potentiometers on the bases of the transistors (Q301 to Q312). These pots are carefully trimmed for optimum gain and distortion, and should be readjusted only by qualified personnel.

Field checks on this assembly should be limited to checking for the proper RF input, and for the proper signals from the +20 V Power Supply and the M104 Leveler module. If these tests show the Amplifier itself to be defective, the unit should be returned to the factory for servicing.

Also included in this assembly are the sweep sample monitor diode, the output monitor diode, and the PIN diode leveler attenuators. The operation of these is discussed in connection with the M104A Leveler module.

### 3.12 M121 – MODULATOR

This module performs four basic functions. It provides the 1 kHz square wave modulation for low-level recovery applications, the oscilloscope horizontal drive signal, the slope signal, and applies the AM signal from an external source to the OUTPUT VERNIER.

#### SQUARE WAVE MODULATION

IC3 and its associated components form a 1 kHz square wave oscillator, the output of which ( $\sim 0$  to +16 V) is used to blank the RF output at a 1 kHz rate. The oscillator is active only when +18 V is applied to module pin 1 via the front-panel 1 kHz MOD pushbutton.

#### SCOPE HORIZONTAL

Resistors R7 and R8 sum the sweep ramp from the M101B Sweep Rate module with a +10 V reference to produce the 0 to +10 V horizontal output signal. This signal is available at the SCOPE HORIZ OUT connector, and is used to drive the horizontal input of an oscilloscope.

#### SLOPE

IC1B amplifies the 1 V/GHz ramp from module pin 9. The amplified ramp is applied to IC1A and IC2. R9 adjusts the gain of IC1A and nulls any internally-produced slope, while the gain of IC2 is controlled by the front-panel SLOPE control. IC4A sums the outputs of IC1B and IC2 and applies the combined signal to the OUTPUT VERNIER. IC4B provides a correction voltage to the Int Slope Null control (mechanically connected to the OUTPUT VERNIER), and thus to the front-panel METER.

## AMPLITUDE MODULATION

The external AM signal from the rear-panel PROGRAMMING jack is buffered by IC4A and applied to the OUTPUT VERNIER, thus modulating the instrument RF output.

### 3.13 M131 – BAND SELECT

This module takes the programming information from the M132 Interface module and provides the signal used to enable each oscillator at the proper time. The M131 also provides the frequency/sweep program for the Sweep Drive modules, the 1 V/GHz reference signal, and the band switch pulse for the M101B and M132.

#### BAND SELECTION

The M131 takes the B2+, B2B+, and B4+ signals from the M132, and the band 3 signal directly from the BAND switch (or PROGRAMMING jack), and converts them to the B-1, B-2A, B-2B, and B-3 oscillator enable signals. IC3A, IC3B, and IC4A are comparators which perform this conversion. IC4B prevents the shifting of the crossover points when the sweep time is changed.

The easiest way to see how the band selection takes place is to examine the selection process for each of the BAND switch (or PROGRAMMING jack) settings.

**Band 1:** The sweep program (all or part of the -10 V to +10 V sweep ramp from the SWEEP WIDTH/STOP control) is inverted by IC1A. R59 and R66 set a reference of ~-13 V at pin 3 of IC3A. Since the inverted sweep ramp applied to pin 2 of IC3A is always more positive than the -13 V reference, comparator IC3A puts out -18 V at all times. This -18 V turns on Q10, which turns on Q14, which causes the -18 V B-1 signal to be put out at module pin 5. The -18 V at IC3A pin 1 also causes comparators IC3B and IC4A (through CR48 and CR39) to put out +18 V, thus keeping the B-2A, B-2B, and B-3 signals at +18 V and the oscillators turned off.

#### NOTE

**In the absence of a +18 V B2+, B4+, or ground band 3 signal, the M131 will default to band 1 programming.**

**Band 2 (front panel):** The +18 V B2+ signal turns on Q9 through CR32, thus turning on Q7 and Q8 which puts ~+18 V at the cathode of CR38. This removes the -18 V at this point and allows R69 to set the reference at pin 5 of IC3B at 0 V. The inverted sweep ramp is applied to IC3B pin 6. During the positive portion of the ramp, IC3B puts out -18 V at pin 7, turning on Q11 and Q15, to put out the -18 V B-2A signal at module pin 16.

During the negative portion of the inverted ramp, the output of IC3B goes positive. The -18 V signal from IC3B pin 7 through CR40 which had held IC4A pin 2 negative is removed, and IC4A pin 2 goes positive due to +18 V through CR36. Pin 1 of IC4A goes negative, turning on Q12 and Q16, thus turning on the -18 V B-2B signal at module pin 15.

The output of IC3A is held positive by +18 V applied to pin 3 through CR31 and CR33. The emitters of Q7 and Q9 are held at near-ground potential since module pin 10 is grounded through an external diode (CR3 on the BAND switch), but Q8 is also turned on, preventing Q6 from turning on.

**Band 2 (PROGRAMMING jack):** The +18 V B2+ signal will turn on only band 2A (500-1000 MHz). If band 2B (1000-1500 MHz) is desired, both the band 2 and band 2B PROGRAMMING jack pins (22 and 21) must be grounded to provide the B2+ and B2B+ signals to the M131. If both bands 2A and 2B are desired, a sensing circuit must be used to detect when the sweep ramp (PROGRAMMING jack pin 8) crosses 0 V. The sensing circuit could then supply (or remove) ground to PROGRAMMING jack pin 22 for band 2B operation.

For band 2A, the +18 V B2+ signal sends the output of IC3B negative as in front-panel operation; however, the reference on pin 5 of IC3B is not 0 V, but a negative voltage. This is true because module pin 10 is not grounded, but floating. Thus, Q9 and Q8 are not turned on. The result is that band 2A is continuously enabled, and even if the voltage at pin 6 of IC3B goes below 0 V, the comparator output remains negative, the B-2A signal remains -18 V, and the band 2A oscillator tries to sweep above its limit (above 1000 MHz). (This oscillator will sweep slightly above 1000 MHz, allowing operation in the vicinity of 1000 MHz without band switching.)

For band 2B, both the +18 V B2+ and B2B+ signals are active. The B2B+ places +18 V on pin 5 of IC3B, keeping band 2A disabled and enabling band 2B. The B2+ signal holds the outputs of the other comparators positive as in front-panel operation. The result is that band 2B is continuously enabled, and if the voltage at pin 2 of IC4A goes above 0 V, the band 2B oscillator will try to sweep below its range (below 1000 MHz). (This oscillator will sweep slightly below 1000 MHz, allowing operation in the vicinity of 1000 MHz without band switching.)

**Band 3:** The band 3 ground signal turns on Q7 which allows Q6 to turn on. This applies ~+18 V to IC3A pin 3, IC3B pin 5, and IC4A pin 3 through CR26, CR35, and CR37. The outputs of IC3A, IC3B, and IC4A are all +18 V, keeping Q10, Q11, and Q12 turned off and their collectors open. This allows Q13 to turn on, which turns on Q17 and thus the -18 V B-3 signal at module pin 14.

Band 4: The +18 V B4+ signal causes the comparator references to be set by R57, R60, and R63. This causes the comparators to change states as the inverted sweep ramp (applied to the inverting inputs) passes through the reference voltage levels. Thus, the oscillator enable signals are turned on sequentially as the sweep progresses.

#### FREQUENCY/SWEEP PROGRAM

This circuit takes the sweep ramp from the M101B and divides it into as many ramps as there are oscillators to be used. The frequency program, sweep ramp, and offset program are summed at the input of amplifier IC1B. The output of the amplifier is the combined frequency/sweep program for the Sweep Drive modules.

During each cycle of the sweep ramp, diodes CR1 through CR3 conduct as selected by the incoming B2+, B4+, and band 3 signals. As each set of diodes conducts, FET switches Q1, Q2, and Q3 switch in resistor sets to change the gain of amplifier IC1B. The -18 V B-1, B-2A, B-2B, and B-3 signals also cause one of the diodes (CR15 through CR18) at the input of IC1B to conduct, switching in a pre-set (via R39 through R46) offset current. In this way, a separate frequency/sweep program can be provided for each oscillator. This is important since each oscillator requires a -10 V to +10 V ramp to program it to sweep its full range (a partial ramp programs only a portion of the range). The offset currents and switched amplifier gain produce the proper frequency/sweep program output for each oscillator as it is enabled.

When band 3 is enabled, FET switch Q3 is off, meaning R13 is in the feedback path of amplifier IC1A. This doubles the integrating time constant of the amplifier, and so

doubles the sweep time of the frequency sweep program for band 3. This is necessary since oscillator 3 sweeps twice the range of oscillators 1, 2A, and 2B, and doubling the sweep time ensures a constant frequency vs. time relationship.

#### 1 V/GHz REFERENCE

The inverted sweep ramp from IC1A is fed into amplifier IC2B. The output of this amplifier is a voltage directly related to the instantaneous RF output frequency as programmed by the sweep ramp. This voltage ranges linearly from 0 V at 0 MHz to 2.5 V at 2500 MHz, and is not affected by the band or oscillator selection.

#### BAND SWITCH PULSE

IC2A and its associated components form a pulse generator which puts out a +18 V 1 msec pulse whenever any of the B-1, B-2A, B-2B, or B-3 oscillator enable signals changes states. This pulse provides a 1 msec delay at the band switching crossover points (the delay circuit is in the M101B), and is used to generate the band stacking blanking and sequence sync pulses in the M132.

#### 3.14 M132 – INTERFACE

This module accepts the band selection signals from either the front-panel BAND switch or the rear-panel PROGRAMMING jack and converts them, via switching transistors, into drive voltages for the M131 Band Select module. The M132 also takes the band switch pulse from the M131 and converts it into the positive and negative Z-axis pulses (for the rear-panel BAND STACKING BLANKING connector) and the sequence sync pulse available at pin 25 of the PROGRAMMING jack.

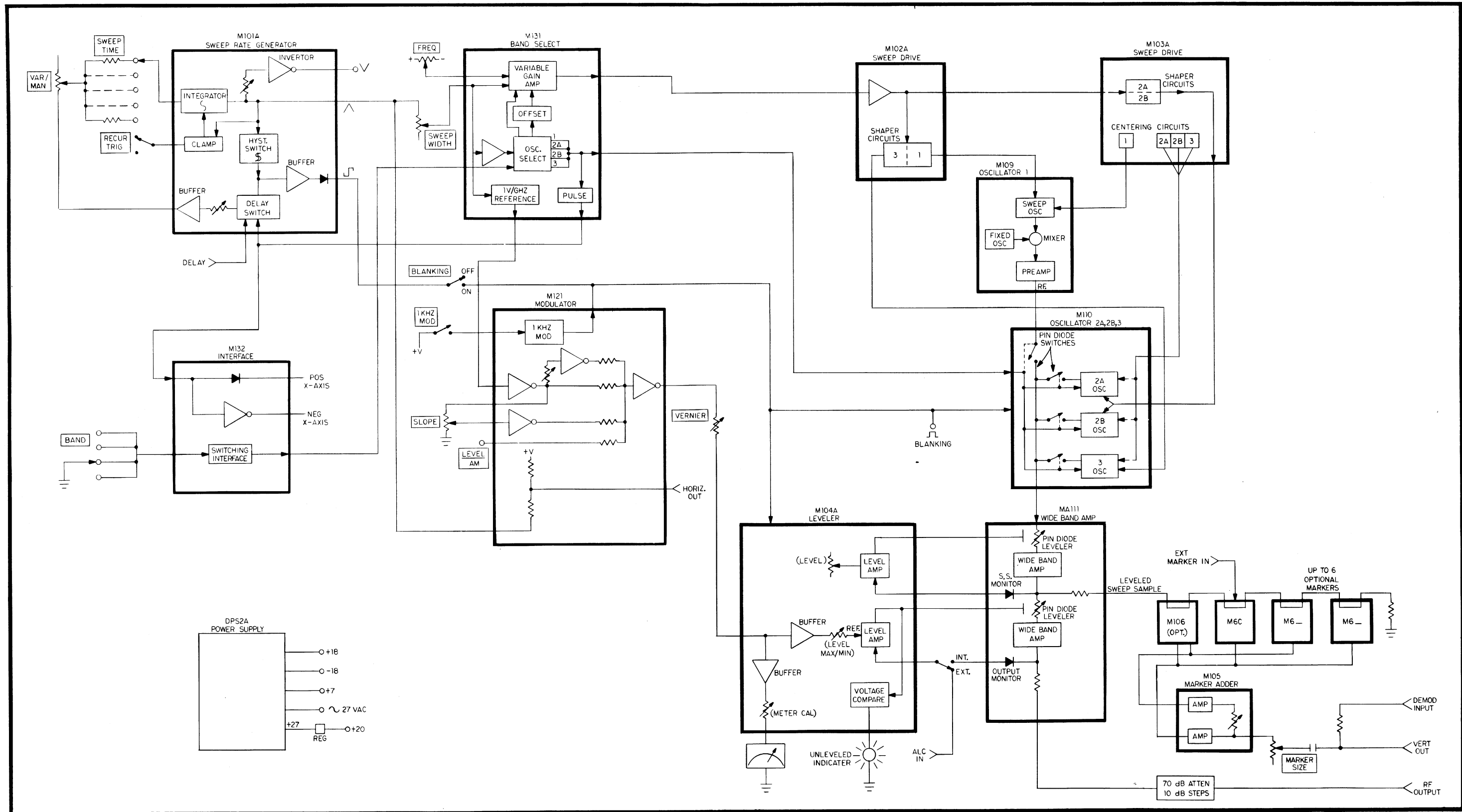

Figure 3-1. Block Diagram

# SECTION 4

## PERFORMANCE TESTS

### 4.1 INTRODUCTION

The purpose of the performance tests in this section is to verify that the Model 2002A Sweep/Signal Generator meets its published specifications (Section 1.2). These tests assume that the instrument is equipped with Option A3, Deluxe Harmonic Markers (Sections 1.2.5 and 1.3.3). This option provides a selective combination of harmonic markers at 1, 10, 50, and 100 MHz intervals throughout the 1 to 2500 MHz frequency range. While it is possible to check the instrument's performance without Option A3 by using suitable external CW sources, a complete check by this method is impractical. The Individual Harmonic Markers, Option A2, can be used up to 1500 MHz only, and are therefore inadequate.

Recommended test equipment is listed in Table 4-1. Tests are normally performed in the order listed. The order conforms to the Specification order in Section 1.2. If tests are performed on Option A3 (Section 4.13.4), the user may perform this test prior to other tests.

Refer to operating instructions in Section 2 to become familiar with Model 2002A controls and their functions prior to beginning these tests. Before applying AC power to the Model 2002A, see Section 2.3 for electrical installation details. The line voltage should be maintained at either 115 or 230 VAC  $\pm 10\%$ , 50 to 400 Hz during the tests. The nominal ambient temperature for tests is 25°C. Correction factors are to be applied as specified in some of the tests at different ambient temperatures.

Table 4-1. Recommended Test Equipment

INSTRUMENT	CRITICAL REQUIREMENT	RECOMMENDED
Oscilloscope	DC coupled, 1 mV/div sensitivity	HP-1200A
Digital Voltmeter	Accuracy: $\pm 0.04\%$	Dana 4200
Power Meter	Frequency Range: 1 MHz to 2500 MHz	HP-435A/8482A
Spectrum Analyzer	Frequency Range: 1 MHz to 5 GHz	HP-8554B/8552B HP-8555A/85552B
Precision Attenuator Pads	10, 20 and 40 dB	Weinchel 50-10, 50-20, 50-40
CW Signal Generator	Adjustable from 1 MHz to 1600 MHz with 0.1 V output, Accuracy: $\pm 10$ MHz	Any suitable signal source covering this frequency range.
Marker Generator	1, 10, 50, 100 Harmonic Markers	Wavetek Option A3
RF Detector	Frequency Range: 1 MHz to 2500 MHz	Wavetek D153
Frequency Counter	Frequency Range: to 500 MHz	HP-5300B/5303B
VSWR Bridge	Frequency Range: 5 MHz to 2 GHz, 40 dB directivity.	Wiltron 60N50

## 4.2 FREQUENCY RANGE AND ACCURACY TESTS

Mechanical dial check: rotate the Model 2002A CENT FREQ/START and SWEEP WIDTH/STOP thumb wheels to their mechanical stops at minimum frequency positions. Both frequency pointers must read  $0 \pm 2$  MHz on the sweep width FREQUENCY SCALE. If they do not, see Section 5.3.3.

### 4.2.1 $\Delta F$ MODE

The frequency range and accuracy are measured using the setup in Figure 4-1. Set the Model 2002A controls as follows:

BAND	1
CENT FREQ	250 MHz
SWEEP WIDTH	500 MHz
MODE	$\Delta F$
STEP ATTENUATOR	+10 dBm
OUTPUT VERNIER	+3 dBm on METER
SWEEP TIME	0.1-0.01 sec
VAR/MANUAL	full cw
HARMONIC MARKERS	50 MHz
MARKER WIDTH	WIDE
TILT/NORM	NORM
TRIG/RECUR	RECUR
SIZE	full down
BLANKING	ON
EXT/INT	INT

The seven MARKER pushbuttons are off (not depressed).

Set the scope's horizontal and vertical inputs for DC coupling. Turn on AC power, and allow the Model 2002A to stabilize for 30 minutes minimum.

Adjust the Model 2002A MARKER SIZE control and the scope's horizontal and vertical sensitivity controls to obtain a display similar to Figure 4-2.

#### NOTE

Adjust the Model 2002A VAR/MANUAL control for optimum viewing on the scope. The sweep time should be fast enough to eliminate flicker, and slow enough to accurately identify the 0 MHz marker (lock-in point). Because of variations in detector, scope, and leveler responses, slight distortions may occur at the low-frequency end of the display. Viewing of the display may be enhanced by disconnecting the detector output from the DEMOD in connector. This provides a horizontal base line with markers. The zero lock-in point is enhanced by depressing the EXT MARKER pushbutton and turning the front-panel BLANKING switch off. The end points of the horizontal line are adjusted to coincide with the left and right graticule

borderlines using scope horizontal position and sensitivity controls. In this test and subsequent tests, use either the detected or the horizontal-line display as desired.

Locate the 500 MHz marker by counting from the zero lock-in point at the lower left corner of the display in 50 MHz steps. Increase the CENT FREQ (left thumb wheel) control setting until the 500 MHz marker is centered in the display. The frequency (green) pointer should indicate approximately 500 MHz. Decrease the SWEEP WIDTH (right thumb wheel) control setting from 500 MHz toward 0 MHz, and adjust the CENT FREQ control until a display similar to Figure 4-3 is obtained. Set the HARMONIC MARKERS switch to 1 MHz, and adjust the CENT FREQ and SWEEP WIDTH controls to position the 499 MHz marker on the left graticule borderline and the 501 MHz marker on the right graticule borderline. This provides a sweep width of 2 MHz.

#### NOTE

Adjust the scope horizontal sensitivity and position controls for a display 10 divisions wide and align on the graticule.

If RF output level is normal (Section 4.9), and vertical deflection is less than 1 volt, check for a faulty detector or and uncalibrated scope.

Operator viewing may be enhanced by turning off blanking and by disconnecting the demodulated signal from the Model 2002A. A horizontal line with markers will then be displayed at the base line.

Set the HARMONIC MARKERS to 50 MHz, and adjust the CENT FREQ control until the zero beat of the 500 MHz marker is centered in the display as shown in Figure 4-3. The green pointer on the FREQUENCY SCALE must indicate between 490 and 510 MHz at an ambient temperature of 25°C.

#### NOTE

If it is necessary to verify that a 500 MHz marker is centered in the display, inject the output of a CW signal generator into the MARKER IN connector of the Model 2002A, and depress the EXT MARKER pushbutton on the front panel. Tune the signal generator until the external marker coincides with the original marker in the display. The signal generator frequency should be 500 MHz. This procedure can be used to identify any marker in subsequent tests.

#### NOTE

Allow  $\pm 0.5$  MHz additional error for each degree ambient temperature difference from 25°C on bands 1 and 2. For



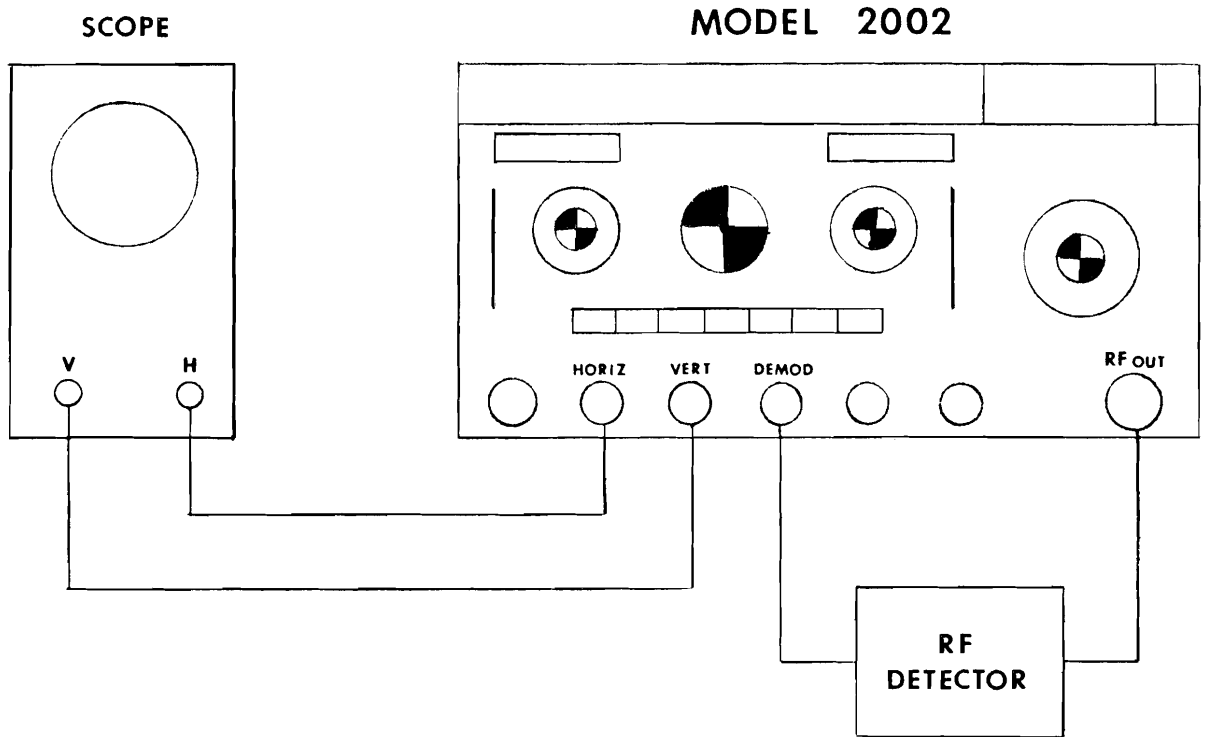

Figure 4-1. Typical Test Set-up

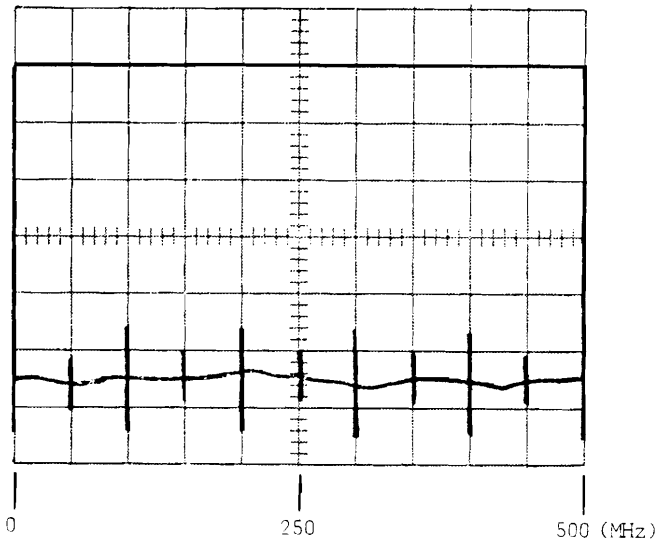

Figure 4-2. Detected RF Display (Band 1)

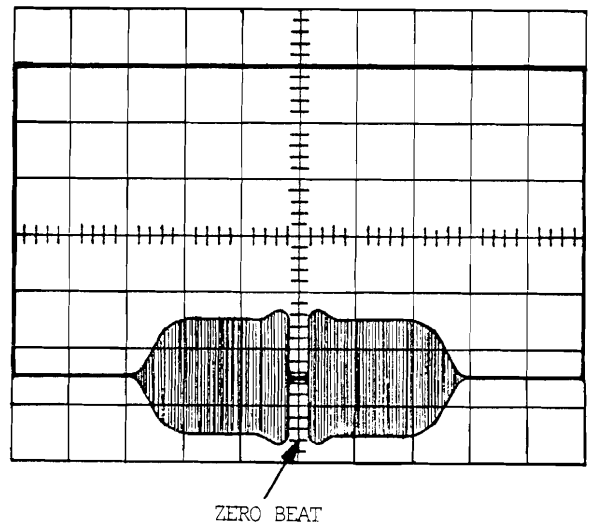

Figure 4-3. Birdy Marker Display (2 MHz Sweep Width)

example, a 20°C ambient temperature increases the allowable error by 2.5 MHz at 500 MHz, and the required FREQUENCY SCALE reading should be between 487.5 and 512.5 MHz. On band 3, the temperature correction factor is 1.0 MHz/°C.

By adjusting only the CENT FREQ control to center markers on the display, continue to verify frequency accuracy at 50 MHz intervals between 450 and 50 MHz. The frequency (green) pointer must indicate the center frequency within 10 MHz +0.5 MHz/°C at each 50 MHz interval.

To verify the 1.0 MHz minimum frequency on band 1, set the HARMONIC MARKERS switch to 1 MHz, and adjust the CENT FREQ control to position the first marker to the right of the zero lock-in point at display center. The centered marker is the 1 MHz marker, and it should be clearly visible in the display. (The flatness down to 1 MHz is measured in Section 4.11.)

Set the HARMONIC MARKERS switch to 50 MHz, and adjust the CENT FREQ control to position the zero lock-in point at display center. Disconnect the RF detector from the DEMOD IN connector to facilitate the adjustment. The green pointer must indicate 0 ±10 MHz +0.5 MHz/°C on the FREQUENCY SCALE.

Use a procedure similar to the one above to measure the frequency accuracy on bands 2 and 3. The allowable error on band 2 is ±20 MHz +0.5 MHz/°C. Use the external marker as needed to identify marker center frequencies. On band 3, the accuracy is verified at 100 MHz intervals using the 100 MHz harmonic markers. The allowable error on band 3 is ±20 MHz +1 MHz/°C. Note that full sweep width spans only half the band.

Set the BAND switch to 4 and check the full 1 to 2500 MHz range at 100 MHz intervals. The allowable error is ±50 MHz plus the applicable temperature compensation factor (0.5 or 1.0 MHz/°C). Note that the maximum sweep width is approximately 500 MHz.

#### 4.2.2 CW MODE

The procedure in Section 4.2.1 measures frequency accuracy at narrow sweep widths. Operation in CW is equivalent to zero sweep width in ΔF, except that no markers appear and blanking is inactive. It is therefore unnecessary, unless desired, to measure frequency range and accuracy in CW mode.

#### 4.2.3 S/S (START/STOP) MODE

The following test measure frequency range and accuracy in the S/S mode. Set the Model 2002A controls as follows:

BAND	1
START	0 MHz
STOP	500 MHz
MODE	S/S

Adjust other controls as in the ΔF mode test (Section 4.2.1). Adjust the START and STOP controls until the 0 and 500 MHz markers coincide with the left and right graticule borderlines as shown in Figure 4-2. The red pointer, which indicates stop frequency, must read between 485 and 515 MHz on the FREQUENCY SCALE at 25°C. Adjust the STOP control until the 450 MHz marker coincides with the right graticule borderline. The red pointer must read between 435 and 465 MHz on the FREQUENCY SCALE at 25°C. Repeat the above test at each 50 MHz interval to the MHz lock-in point. The allowable error is ±15 MHz +0.5 MHz/°C difference from 25°C ambient temperature.

Readjust the STOP control until the 500 MHz marker coincides with the right graticule borderline, and adjust the START control, if required, until the 0 MHz lock-in point coincides with the left graticule borderline. The start frequency (green) pointer must read between -15 and +15 MHz on the FREQUENCY SCALE at 25°C. By adjusting only the START control to position the markers, repeat the above test at each 50 MHz interval to 500 MHz. The allowable error is ±15 MHz +0.5 MHz/°C.

Repeat the above tests on bands 2 and 3 at each 100 MHz interval. (Use 100 MHz harmonic markers.) The allowable error on band 2 is ±30 MHz + 0.5 MHz/°C, and on band 3, ±30 MHz + 1 MHz/°C.

Set the BAND switch to 4 and check the full 1 to 2500 MHz range at 100 MHz intervals. The allowable error is ±50 MHz plus the applicable temperature compensation factor (0.5 or 1.0 MHz/°C).

#### 4.3 SWEEP WIDTH TEST

Using the setup in Figure 4-1 and the control settings in Section 4.2.1, obtain a display as in Figure 4-2, with lower corners that coincide with the left and right graticule borderlines. Adjust the CENT FREQ and SWEEP WIDTH controls until the 500 MHz marker coincides with the right graticule border line, and the 0 MHz lock-in point coincides with the left graticule borderline. The red pointer on the sweep width FREQUENCY SCALE must indicate 500 ±15 MHz +0.5 MHz/°C difference from 25°C ambient temperature.

Adjust the SWEEP WIDTH control to 100 MHz and the CENT FREQ control to 300 MHz. Adjust both controls until the 250 MHz marker coincides with the left borderline

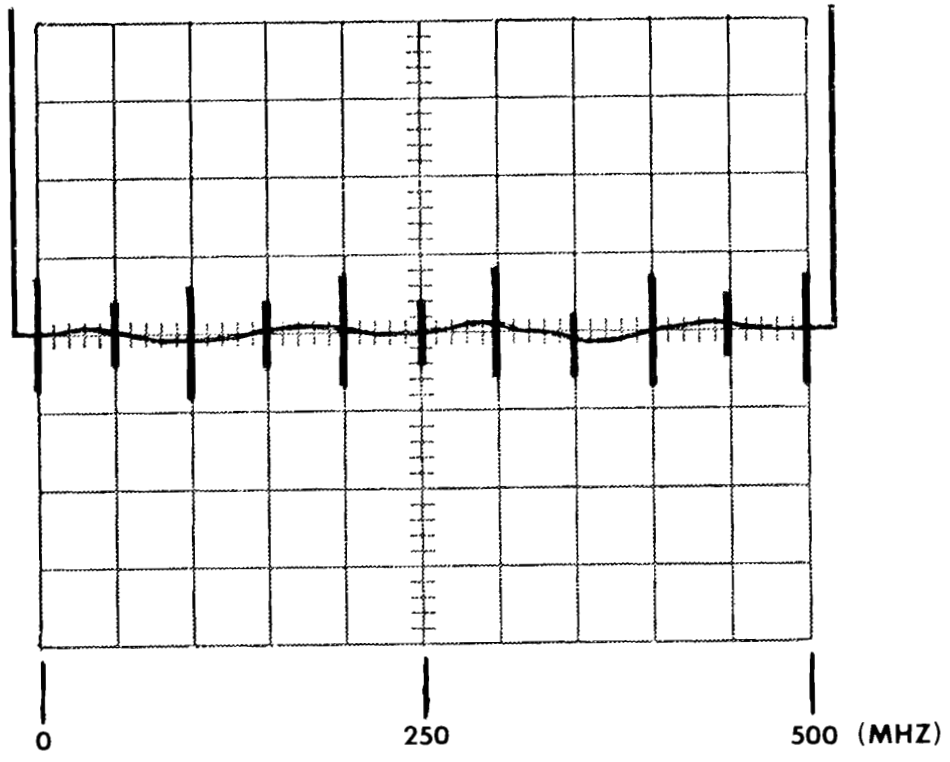

Figure 4-4. Linearity Display (Band 1)

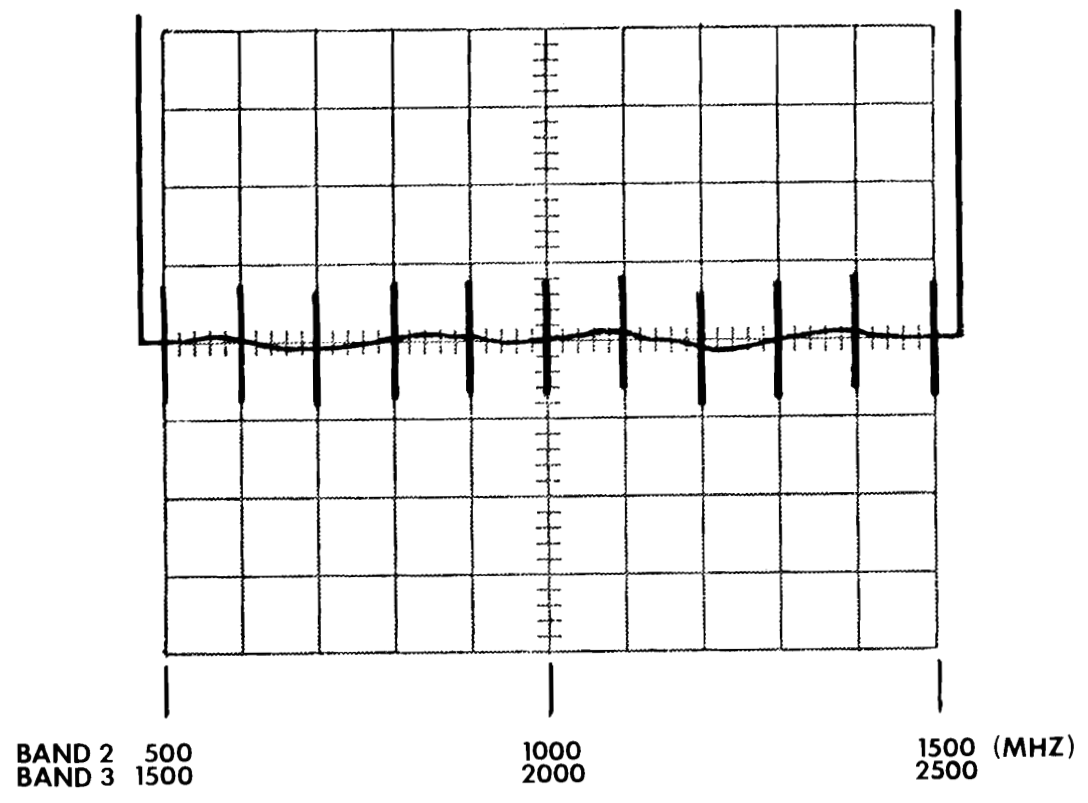

Figure 4-5. Linearity Display (Bands 2,3)

and the 350 MHz marker coincides with the right borderline of the graticule. The red pointer on the sweep width FREQUENCY SCALE must indicate  $100 \pm 15$  MHz  $+0.5$  MHz/ $^{\circ}$ C difference from  $25^{\circ}$ C ambient temperature.

Set the HARMONIC MARKERS selector to 1 MHz. Adjust the CENT FREQ and SWEEP WIDTH controls for a sweep width of exactly 1 MHz at any center frequency between 1 and 500 MHz. Adjust the CENT FREQ control to center a 1 MHz marker on the display. Set the MARKER WIDTH control to produce a marker approximately 200 kHz wide on the display.

Next, adjust the SWEEP WIDTH control toward minimum. The 200 kHz wide marker should expand horizontally to fill the display. This procedure verifies minimum sweep width requirements.

Repeat the above procedures for bands 2, and 3. The allowable sweep width error is  $\pm 30$  MHz  $+0.5$  MHz/ $^{\circ}$ C difference from  $25^{\circ}$ C ambient on band 2. On band 3, the allowable error is  $\pm 30$  MHz  $+1.0$  MHz/ $^{\circ}$ C. Minimum sweep width should be 200 kHz on all bands. When checking 500 MHz sweep width on bands 2 and 3, set the CENT FREQ control to any 50 MHz interval near the center of the band.

The frequency accuracy measured in the preceding tests is closely related to display linearity, which is measured in the following test.

#### 4.4 DISPLAY LINEARITY TEST

Display linearity is measured at the band limits in the S/S MODE only. Use the setup in Figure 4-1, and set the controls as in Section 4.2.3, except adjust the scope horizontal position and sensitivity controls to over-sweep both ends of the graticule approximately 1/2 division. Adjust the START and STOP controls until each marker in the comb (including the 0 and 500 MHz markers) coincides with its corresponding vertical graticule line within 0.1 division (0.5 minor division). This allowable error is equivalent to a 1% linearity. (See Figure 4-4.)

#### NOTE

**If the horizontal linearity of the scope is improperly calibrated, the above test is invalid. Refer to the scope linearity check in Section 5.3.3 in this manual.**

Repeat the above procedure on bands 2 and 3. The allowable linearity error is  $\pm 0.1$  division on all bands. (Use 100 MHz harmonic markers.) (See Figure 4-5.)

## 4.5 SPURIOUS SIGNAL TEST

### 4.5.1 HARMONICS AND NON-HARMONICS

A spectrum analyzer covering the range of 1 MHz to 5 GHz is required for this test. Measurements are made in accordance with instructions furnished with the analyzer. The Model 2002A is set to CW mode. All markers should be turned off. The RF output of the Model 2002A is connected to the RF input of the spectrum analyzer.

The second and third harmonics of the output signal are usually the main spurious signals on all bands. These harmonics should be at least 20 dB below the carrier between 1 and 10 MHz, and at least 30 dB below the carrier between 10 and 2500 MHz.

Non-harmonic spurious signals are generated by a heterodyne oscillator on band 1. These spurious signals should be at least 35 dB below the carrier in the band (1 to 500 MHz), and at least 30 dB below the carrier outside the band. No non-harmonics should be detectable on bands 2 or 3, since fundamental oscillators are used.

### 4.5.2 RESIDUAL FM TEST

A spectrum analyzer is used to measure residual FM. The residual FM should be measured at the maximum frequency in each of the bands, and at any other desired frequencies in the range of 1 to 2500 MHz. The Model 2002A is set to CW mode. All markers are turned off. The RF output of the Model 2002A is connected to the RF input of the spectrum analyzer, and is set to +13 dBm. The spectrum analyzer is tuned to the fundamental of the Model 2002A.

With the spectrum analyzer set according for 3 kHz bandwidth, internal scan mode, 10 kHz/division scan width, 0.2 sec/division scan time, and 10 dB/division sensitivity, the residual FM should be less than 10 kHz peak-to-peak on bands 1 and 3, and less than 20 kHz peak-to-peak on band 3. The peak-to-peak measurement refers to the difference between the maximum and minimum frequencies of the signal peak which is observed as horizontal jitter on the spectrum analyzer. (See Figure 4-6.)

### 4.6 FREQUENCY DRIFT TEST

Frequency drift should be measured at 500, 100, 1500, and 2500 MHz (the highest frequency of each oscillator), and at any other desired frequencies between 1 and 2500 MHz. Use the setup and control settings of Section 4.2.1, except

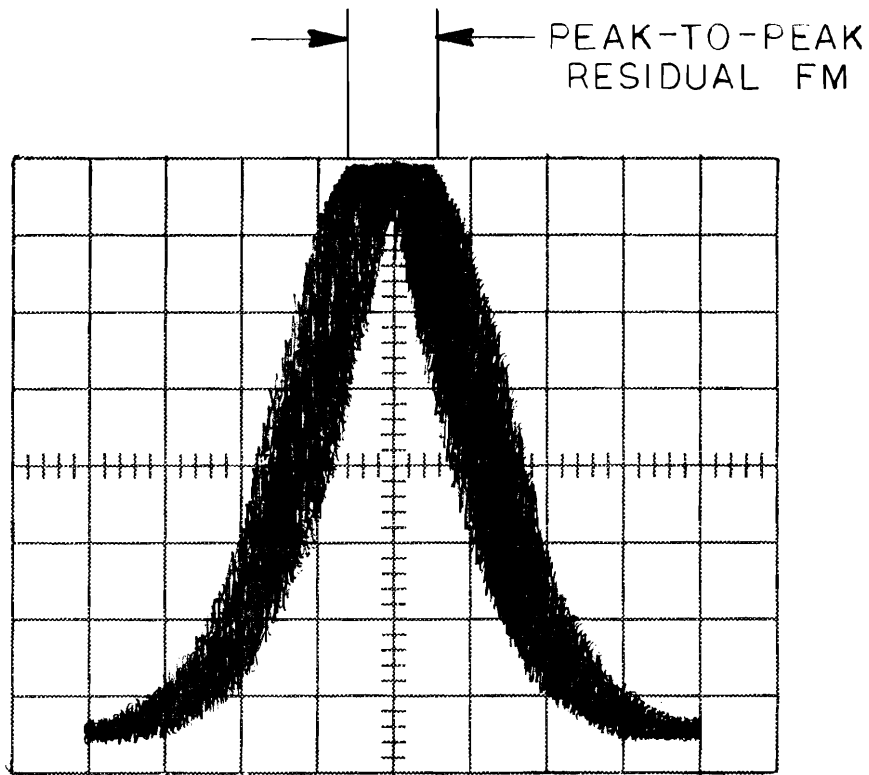

Figure 4-6. Residual FM

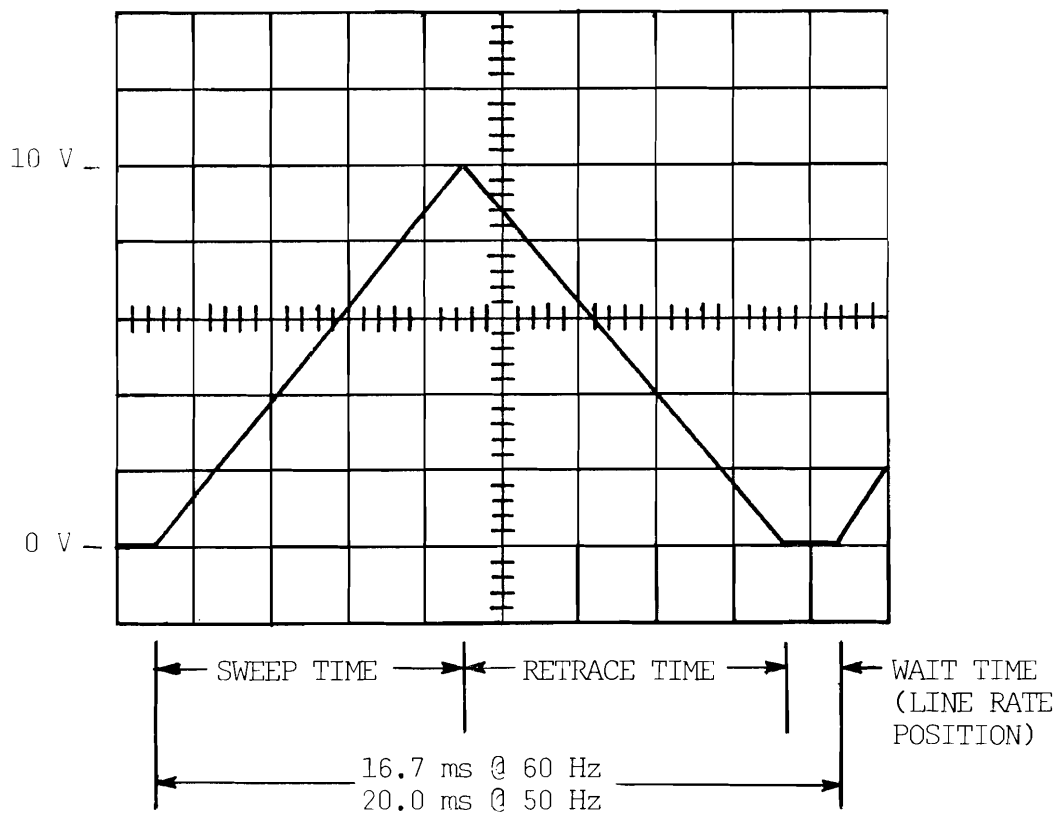

Figure 4-7. Horizontal Output Waveform

calibrate the display's sweep width to exactly 1 MHz and center the marker (for example, 500 MHz) on the display with the SWEEP TIME switch set to LINE. Read frequency drift directly from the scope display by noting the change in the marker's position with time. Each division represents 100 kHz. When reading drift over long periods of time, calibrate the display's sweep width to 5 MHz using 1 MHz harmonic markers. Next, turn off the 1 MHz markers and turn on the 10 MHz (or 50 MHz) harmonic markers. Center a marker on the scope display and read drift as before, except 1 division now equals 500 kHz.

The maximum allowable drift on bands 1 and 2 is 100 kHz per 5 minutes, or 2 MHz per 8 hours. This specification applies after a one-hour minimum warmup at a constant ambient temperature, and allowing a 5 minute stabilizing period after a frequency change. On band 3, the maximum allowable drift is 200 kHz per 5 minutes, or 4 MHz per 8 hours.

#### 4.7 BLANKING TEST

With the front-panel BLANKING switch turned on, the RF output in S/S and  $\Delta F$  modes is removed during the sweep retrace time to provide a zero-volt base line. Use the setup in Figure 4-1 and preset the controls as in Sections 4.2.1 or 4.2.2. The display should be as shown in Figure 4-2. Set the BLANKING switch to its up position, and verify that the zero-volt base line is removed from the display. Repeat this test on bands 2 and 3. Reset the BLANKING switch to ON.

#### 4.8 OUTPUT IMPEDANCE AND SWR TEST

A 50 ohm SWR bridge, a spectrum analyzer, and a signal generator are required for this test.

The output impedance and SWR of the Model 2002A are measured in combination, and the result is expressed as return loss which may be directly converted to SWR. The Model 2002A and the signal generator, both operating in CW mode, are set to the same output level and test frequency. The system is calibrated with the test port of the SWR bridge open and a 0 dB return loss reference is set on the spectrum analyzer. The Model 2002A is then connected to the test port of the SWR bridge. The SWR of the Model 2002A is obtained from the return loss indication on the spectrum analyzer as the signal generator is tuned through the test frequency range. The return loss indication is disregarded at points where the two frequencies are exactly equal. The SWR should be less than 1.5:1 (return loss greater than 14 dB) with the Model 2002A OUTPUT STEP ATTENUATOR set to 0 dBm (10 dB insertion loss). The SWR should be less than 1.3:1 (return loss greater than 7 dB) with the OUTPUT STEP ATTENUATOR set to -10 dBm (20 dB insertion loss).

#### 4.9 RF OUTPUT MAXIMUM LEVEL TEST

This measurement is made with a power meter. Set the power meter to its +15 dBm range. Set the Model 2002A controls as in Section 4.2.1, except set the MODE switch to CW. Connect the power sensor to the RF OUT connector of the Model 2002A. The power meter must read between +12.5 and +13.5 dBm. RF output flatness is measured in Section 4.11.

#### 4.10 RF OUTPUT ATTENUATION AND ACCURACY TESTS

##### 4.10.1 STEP ATTENUATOR

The Step Attenuator provides 70 dB of attenuation in 10 dB steps. The accuracy can be measured by using a suitable attenuation test set, or by directly substituting precision RF attenuator pads for each 10 dB step of the Attenuator. The difference between the two outputs represents the Attenuator error. An RF detector can be used to recover the signal at levels down to approximately -40 dBm. Below this level, an RF amplifier or a sensitive receiver (spectrum analyzer) must be used. The allowable error is  $\pm 3\%$  of the attenuation. The maximum error, which is at 70 dB, is  $\pm 2.1$  dB. This error is produced by the Step Attenuator alone, and does not include the flatness or the OUTPUT VERNIER ATTENUATOR error.

##### 4.10.2 VERNIER ATTENUATOR

The accuracy of the OUTPUT VERNIER ATTENUATOR is measured using the power meter while operating the instrument in CW mode on band 1 at 250 MHz. With the OUTPUT STEP ATTENUATOR set to +10 dBm, adjust the VERNIER for a +3 dBm reading on the output METER. The power meter should read  $+13 \pm 0.5$  dBm. Using the OUTPUT VERNIER only, check the output METER readings in 1 dB steps between +3 and -10 dB. The power meter reading at each step should be within 0.5 dB of the indicated output level (the sum of the output METER reading and the OUTPUT STEP ATTENUATOR setting). The output is not specified below -10 dBm output METER readings.

#### 4.11 RF OUTPUT FLATNESS TEST

Flatness is the variation in output amplitude versus frequency. It is normally measured with a power meter, but it can be measured with a broadband negative-polarity RF detector. The power meter method is preferred, since its flatness is better than most RF detectors. A power sensor is used with the power meter, and a calibration chart is affixed to the sensor. At the operating frequency, a calibration factor noted on the chart is set on the power meter's calibration factor control, and a corrected reading is obtained from the power meter.

The flatness is measured in the S/S mode with the SWEEP TIME switch set to MANUAL. The BAND switch is set to 4, and the VAR/MANUAL control is adjusted through its range. The SLOPE control must be adjusted for zero slope. The power meter is set to its +15 dBm scale and connected to the RF OUT connector of the Model 2002A.

To read flatness down to the 1 MHz minimum, first calibrate the scope display from 0 to 10 MHz as follows. Set the SWEEP TIME selector to LINE and set the START control to -10 MHz and the STOP control to +10 MHz. Turn off all markers and depress the EXT MARKER pushbutton to activate the 0 MHz marker. The 0 MHz marker should appear near the display center. Turn on the 10 MHz harmonic markers. Adjust the START control to position the 0 MHz marker on the left graticule borderline, and the STOP control to position the 10 MHz marker on the right graticule borderline. Turn off the EXT MARKER and turn on the 1 MHz harmonic markers. With the SWEEP TIME selector set to MANUAL, adjust the VAR/MANUAL control to position the zero beat of the 1 MHz marker approximately one division from the left borderline of the display graticule. Turn off the markers. Set the proper calibration factor and read the power meter. (The power meter will null if the VAR/MANUAL control is set to the zero beat of the 0 MHz marker.) Tune the 1 to 10 MHz range with the VAR/MANUAL control and note the power meter readings.

Set the START and STOP controls to 10 and 2500 MHz respectively. Tune the entire frequency range with the VAR/MANUAL control. Note the frequency where the maximum corrected power meter reading is obtained. Use the OUTPUT VERNIER to adjust the corrected output level to exactly +13 dBm at that frequency where the maximum output level occurs. Again tune the full range and note the minimum corrected power meter reading. A minimum reading of at least +12 dBm is required to meet the  $\pm 0.5$  dB flatness specification.

#### NOTE

If a detected swept response is to be observed, the lowest detected output level should be at least 90% of the highest detected level at sweep rates up to 100 MHz/ms. At faster rates, the overall flatness may deteriorate slightly.

#### 4.12 SWEEP TIME (HORIZONTAL OUTPUT) TEST

Connect the Model 2002A HORIZ OUT connector to the scope vertical input. Adjust the scope controls for an internally generated, automatic, line-triggered sweep of 2 mV/division, and a vertical sensitivity of 2 V/division. Set the Model 2002A BAND switch to 1, the SWEEP TIME selector to LINE, and the TRIG/RECUR switch to RECUR (full down position). Adjust the scope's vertical position, horizontal position, and trigger level to obtain a waveform as shown in Figure 4.7.

Set the SWEEP TIME selector to 0.1 – 0.01 sec and the VAR/MANUAL control fully clockwise. The wait time should disappear and the sweep time should be less than 10 ms with approximately equal sweep time (rising) and retrace time (falling) periods. Set the scope time base to 20 ms/division. Adjust the VAR/MANUAL control fully counterclockwise. The sweep time should be greater than 100 ms with approximately a 10:1 ratio between the sweep and retrace time periods.

#### NOTE

The retrace time period remains fairly constant at any SWEEP TIME setting as the VAR/MANUAL control varies the total sweep time period. With the VAR/MANUAL control fully clockwise, the sweep and retrace times are both 0.01 seconds. With the control fully counterclockwise, the sweep time is approximately 0.1 seconds and the retrace time remains 0.01 seconds. On the next lower range (1 - .1), the retrace time should be a constant 0.1 seconds, and the sweep time should vary from 0.1 to 1 second.

Repeat the previous checks for the 1 - .1, 10 - 1, and 100 - 10 second positions on the SWEEP TIME selector switch. Adjust the scope time base as necessary to ensure that the VAR/MANUAL control will adjust the sweep time from greater than the maximum to less than the minimum time specified for each range.

Set the SWEEP TIME selector to MANUAL and adjust the VAR/MANUAL control throughout its range. A DC voltage should be present at the HORIZ OUT connector that is variable from  $0 \pm 0.5$  V with the control fully counterclockwise to  $+10 \pm 0.5$  V with the control fully clockwise. Use a DVM for this measurement.

Set the SWEEP TIME selector to the .1 - .01 position and the TRIG/RECUR switch to its middle position. The sweep should be disabled. Moving the TRIG/RECUR switch to the full up (spring-loaded) position and then releasing it should produce one complete sweep cycle.

#### NOTE

The triggered mode of operation is possible only in the variable rate positions, and will not operate in the LINE or MANUAL positions of the SWEEP TIME selector.

#### 4.13 MARKER SYSTEM TESTS

The Model 2002A utilizes a birdy-bypass marker system which provides for both internal and external markers. A CW signal generator is used to check out the external system. Option A3, which provides a combination of 1, 10, 50, and 100 MHz harmonic markers, is required to fully check out the internal marker system.

A front-panel rotary switch (labeled HARMONIC MARKERS) selects the desired comb in Option A3. An internal operator control on module M105 (labeled Size Ratio) adjusts the ratio of small to full-size markers in the comb to facilitate identification in all marker options. Other markers, Options A1 and A2, if installed, and the external marker, are individually selected by label from the row of seven front-panel MARKER pushbutton switches. All marker geometries (size, width, tilt, and rectification) are controlled from front-panel switches and controls. In addition, all markers have internal Size controls (see Section 5.3.6 for adjustment procedure).

#### 4.13.1 EXTERNAL MARKER

Use the setup in Figure 4-1 and connect the CW output of a signal generator to the Model 2002A MARKER IN connector. Set controls as in Section 4.2.3, and adjust the MARKER SIZE control to obtain a display similar to Figure 4-2. Set the signal generator for a 100 mV CW output, and depress the Model 2002A EXT MARKER pushbutton. Tune the signal generator from 1 to 500 MHz and note the movement of the external birdy in the display. The fundamental external birdy amplitude should be approximately equal to the amplitude of the even harmonic markers in the comb. The amplitude of second and third harmonics of the external signal, when in the band, may also be approximately equal to the fundamental marker amplitude.

When operating on band 2 or 3, the second, third, or higher harmonics of the external signal generator carrier may be required to verify operation of the external marker system on signal generators with limited maximum frequency. Increasing the level of the carrier may be required.

#### 4.13.2 SINGLE FREQUENCY MARKER (OPTION A1)

Use the procedure in the previous sections, and depress the correct pushbutton for the single frequency marker to be tested. Turn off all other markers, and set the BAND switch for the correct band to display the single frequency marker. Adjust the CENT FREQ control to center the marker on the display, and read the FREQUENCY SCALE to identify the marker within 5 MHz.

#### 4.13.3 INDIVIDUAL HARMONIC MARKERS (OPTION A2)

Option A2 provides a harmonic marker comb up to 1500 MHz. Use the setup and procedure in Section 4.2.3, except depress the appropriate pushbutton in the row of MARKER switches (50 HAR, for example), and turn off all other markers.

The Option A2 markers can be tested using a procedure similar to Section 4.13.4, except the maximum operating frequency is 1500 MHz for the individual harmonic markers.

#### 4.13.4 DELUXE HARMONIC MARKERS (OPTION A3)

The Option A3 harmonic markers are used in several previous performance tests. The 1, 10, 50, and 100 MHz harmonic (comb) markers are controlled by the front-panel HARMONIC MARKERS rotary switch. To check out the Option A3 markers, proceed as follows.

#### NOTE

**The following tests for marker frequency accuracy, marker width, size, rectification and tilt are made with the 50 MHz harmonic markers. Other markers can be tested using a similar procedure.**

#### MARKER ACCURACY

Marker accuracy can be verified by any one of several methods. In one method, a frequency counter measures the RF output frequency of the Model 2002A as follows: A convenient harmonic marker (preferably near the counter's maximum frequency) or a single frequency marker is displayed on the scope with the Model 2002A operating in  $\Delta F$  mode with a sweep width of approximately 1 MHz. The sweep time is then set to MANUAL, and the VAR/MANUAL control is adjusted for a zero beat of the displayed marker. The marker's frequency is read on the frequency counter. For example, a 500 MHz marker should read 500 MHz  $\pm 25$  kHz. The allowable error is as follows: 0.005% at 25°C and 0.007% at 0 to 50°C for Options A1 and A2. For Option A3, the allowable error is 0.005% at 0 to 50°C. Since the error is quite small, a higher harmonic frequency provides an error which is more easily read on the counter. On Option A3, a single crystal reference is used for all harmonic frequencies, and only a single measurement is required.

A second method uses a tunable frequency synthesizer as an external marker. With the Model 2002A operating in  $\Delta F$  mode, a test marker is displayed at 1 MHz sweep width. The synthesizer is tuned until its zero beat coincides in the scope display with the zero beat of the test marker.

A third method uses a frequency counter only, but requires removal of the instrument and marker covers. A probe from the marker oscillator section to the counter is adjusted for a signal level sufficient for the counter to accurately read the crystal frequency.



The highest crystal frequency used in the Model 2002A is 50 MHz. Markers above 50 MHz use harmonics of a given crystal frequency.

Test equipment for marker accuracy is not listed in Table 4-1, since the inherent stability of quartz crystals makes a marker accuracy check unnecessary in all but the most critical applications.

#### MARKER WIDTH

Repeat the setup in Figure 4-1, and set the Model 2002A controls to position a 2500 MHz marker on the display at a sweep width of exactly 1 MHz. Other controls should be initially set as in Section 4.2.1. Adjust the MARKER SIZE control and scope vertical sensitivity for a 2 Vpp marker display.

Adjust the CENT FREQ control to center the marker's zero beat on the scope display. With the MARKER WIDTH switch set to WIDE, note that the displayed marker width is approximately 400 kHz (each horizontal division equals 100 kHz). Decrease MARKER WIDTH in successive steps to NARROW, and note that the marker width decreases in steps to approximately 15 kHz at NARROW.

#### NOTE

**Marker width is also a function of internal marker Size controls. The above check applies to normal settings of internal marker controls.**

#### MARKER SIZE

Set Model 2002A controls as in Section 4.3.2, and observe the 50 MHz marker comb from 50 to 500 MHz. Note that even harmonic markers (100, 200, . . . etc.) have a uniform amplitude in the display. The odd harmonic markers (50, 150, . . . etc.) have a smaller, but uniform amplitude. The relative amplitude or size is determined by the internal Size Ratio control (see Section 5.3.5). The even harmonic of the 50 MHz harmonic markers should be of uniform amplitude throughout all four bands. The odd harmonics should be smaller, but of uniform amplitude throughout all bands.

Set the MODE switch to  $\Delta F$  and center the 2500 MHz marker on the display at a sweep width of approximately 2 MHz using the CENT FREQ and SWEEP WIDTH controls on band 3. Set the scope's vertical sensitivity and position controls as required to read marker amplitude in the following steps. With the front-panel SIZE paddle switch fully depressed (to the large diamond), rotate the MARKER SIZE control throughout its range. The displayed marker amplitude should vary from approximately 4 Vpp at the clockwise limit to

approximately 10 mVpp at the counterclockwise limit. Set the SIZE paddle switch to mid-position (small diamond). Again rotate the MARKER SIZE control throughout its range. The displayed marker amplitude should vary from approximately 25 mVpp to approximately 50  $\mu$ Vpp.

#### MARKER RECTIFICATION

Set the SIZE paddle switch to full up position (triangle). This position provides positive rectified birdy markers for use with X-Y plotters. With the SWEEP TIME selector set to .1 - .01, adjust the VAR/MANUAL control fully counterclockwise. Disconnect the RF detector from the DEMOD IN connector on the Model 2002A and rotate the MARKER SIZE control throughout its range. With the scope properly adjusted, the marker amplitude should vary from approximately 2 V to 1 mV. The rectified marker amplitude depends upon the RF detector impedance when connected to the DEMOD IN connector. With the DEMOD IN connector center conductor shorted to ground, the voltages should vary from approximately 0.2 V to 1 mV.

#### MARKER TILT

Center the 2500 MHz marker in the display at a sweep width of approximately 200 MHz. Set the TILT/NORM switch to TILT and the SIZE paddle switch to full down position. While adjusting the MARKER SIZE control throughout its range, note that the marker is adjustable from a 4 Vpp nearly vertical marker to a horizontal marker equal to approximately 10% of the horizontal display (1 division of 10).

#### 4.14 EXTERNAL PROGRAMMING

External programming inputs are not normally checked at incoming inspection unless these special functions are to be used in a particular application. The program input signals, external controls necessary, and input pin connections are covered in Section 2, Operation. If it is necessary to check these functions at incoming inspection, reference can be made to that section of the manual for complete setup instructions.

#### 4.15 SLOPE TEST

Set the BAND switch to 4, the MODE switch to S/S, and the START and STOP controls to 1 and 2500 MHz, respectively. Use the OUTPUT VERNIER to calibrate levels of 7.5, +10, and +12.5 dBm on the scope display (refer to Figure 4-7). Reset the OUTPUT VERNIER for a +10 dBm output (0 dBm on output METER). Use a screwdriver to adjust the front-panel SLOPE control fully clockwise. When viewed on the scope display, the output at 2500 MHz should be approximately +12.5 dBm and the output at 1 MHz should still be +10 dBm. Adjust the

SLOPE control fully counterclockwise. The output at 2500 MHz should be approximately +7.5 dBm and the output at 1 MHz should still be +10 dBm when viewed on the display. The sloped line should be approximately linear.

#### **4.16 1 KHZ MODULATION TEST**

Set the BAND switch to 4, the MODE switch to S/S, the START control to 1 MHz, the STOP control to 2500 MHz, the SWEEP TIME selector to MANUAL, and the VAR/MANUAL control fully ccw. Turn off all markers and blanking. Turn the 1 kHz MOD pushbutton switch on and set the scope for 0.2 msec/division on the horizontal time base, internally triggered. A waveform (approximately square) with a period of 1 msec should be displayed. The

amplitude of the waveform should be equal to that of the unmodulated waveform. Tune the VAR/MANUAL control throughout its range and note the amplitude of the waveform at all frequencies. Turn the 1 kHz MOD switch off.

#### **4.17 PEN LIFT (OPTION B4)**

Two terminals are provided on the rear panel which provide contact closure during forward sweep time. Pen lift occurs only in the 1 - 10 and 10 - 100 positions of the SWEEP TIME control. The unit is tested with an X-Y plotter or with a VOM to indicate contact closure during the sweep trace interval. The marker SIZE paddle switch should be in its full up position when checking markers with an X-Y plotter.

# SECTION 5

## MAINTENANCE

### 5.1 INTRODUCTION

This section provides information for servicing, calibrating, and troubleshooting the Model 2002A Sweep/Signal Generator.

### 5.2 SERVICE INFORMATION

#### 5.2.1 DISASSEMBLY INFORMATION

Refer to Figure 5-1.

**REMOVAL OF BOTTOM COVER** - Remove two rear feet (A) and lift cover off with a slight rear movement. Reinstall cover by reversing the removal procedure.

**REMOVAL OF TOP COVER** - Remove the single screw (B) from top and lift off cover with a slight rear movement. Reinstall cover by reversing the removal procedure.

**REMOVAL OF SIDE PANEL** - To remove the right side panel, refer to Section 5.2.3. To remove the left-side panel, remove the six screws (E) holding the side panel to the instrument. However, one side panel must remain on the instrument to secure the front-panel assembly to the chassis.

#### CAUTION

To prevent possible damage to harness when reinstalling side panels, use only the original screws or equivalent. Longer screws in the bottom two holes can cause damage to wiring.

#### 5.2.2 MODULE SERVICING

**REMOVAL OF MODULE** - Modules may be replaced by removing any cables attached to top of the modules and

removing hold-down screw (C) from bottom. Rock module slightly while lifting upward to free module from chassis socket.

**REMOVAL OF MODULE COVER** - Remove all nuts and screws from top of module and slide cover off.

**REINSTALLING MODULE** - Before installing the module, check that module pins are straight and properly aligned; then carefully seat module pins into the chassis socket, replace module hold-down screw (C) to insure a good ground connection between module and chassis, and replace any cables attached to top of module. Module cable connections are shown in Figure 5-22.

#### NOTE

If a defective module is replaced with a new module, certain calibration procedures must be repeated as shown in the following list:

MODULE	PROCEDURE	SECTION
M101B	Sweep Rate	5.3.2
M102A	Frequency Cal	5.3.3
M103A	Frequency Cal	5.3.3
M104A	Level Cal	5.3.4
M105	None	---
M109	Frequency Cal	5.3.3
M110	Frequency Cal	5.3.3
MA111	Level Cal	5.3.4
M121	1 kHz Mod Adj	5.3.5
M131	Frequency Cal	5.3.3
M132	None	---
M6C	None	---
M6H	Marker Size	5.3.6
M6S	Marker Size	5.3.6
M106	Marker Size	5.3.6

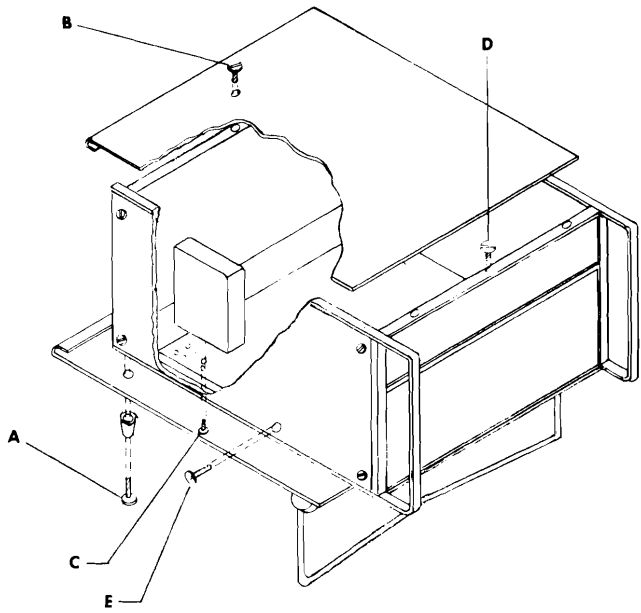

Figure 5-1. Disassembly

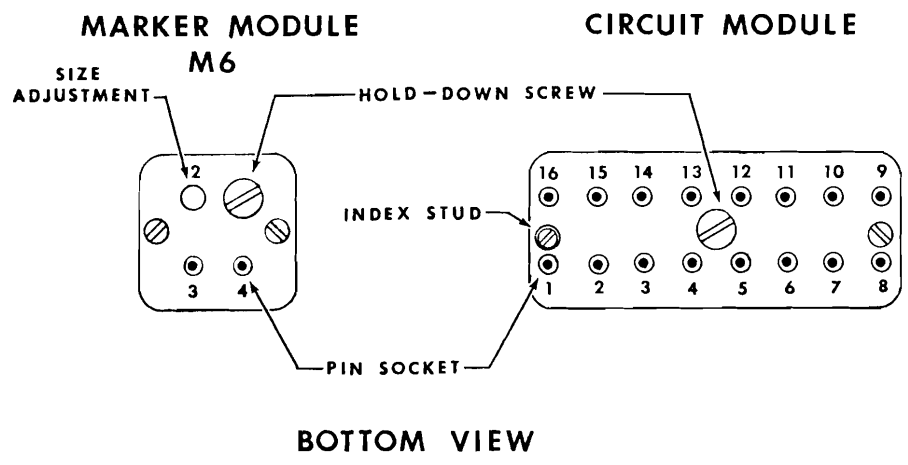

Figure 5-2. Module Pin Configuration

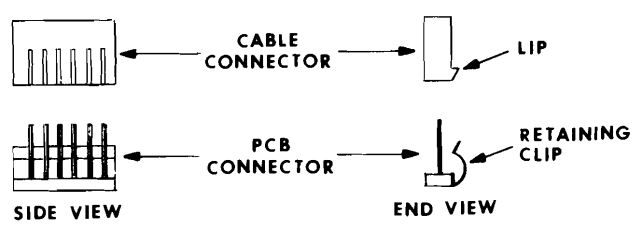

Figure 5-3. Connector Alignment

SERVICE KIT K005 - This kit contains a module extender, RF extension cables, and adapters which enable a module to be electrically operated while physically located above the rest of the modules, thereby making all parts easily accessible.

MODULE-PIN NUMBERING SYSTEM - The module pins are numbered as shown in Figure 5-2. The off-center index stud prevents the module's being plugged in backward and also provides a method for locating pin 1.

#### NOTE

**All 16 pins are not required in each module. Only the pins actually used are installed, but the numbering system remains the same.**

#### 5.2.3 OUTPUT AMPLIFIER SERVICING (MA111)

Refer to Figure 5-22. First remove cable W2 from the Amplifier and the M110 Sweep Oscillator. Remove the sweep sample cable, W5, from the Amplifier, and remove the output cable W3 from the Step Attenuator. (Do not attempt to remove cable W3 from the Amplifier yet.) Next, remove the 6 screws holding the right-side panel to the instrument (screws (E) in Figure 5-1). Do not remove the two screws in the side panel holding the Amplifier to the side panel. The right-side panel can now be removed from the instrument, which will provide access to the Amplifier. The Amplifier can be operated in this position by substituting for cable W2 with a longer flexible cable provided in the service kit. Remove cable W3 from the Amplifier output and connect an RF detector or power meter directly to the Amplifier output to check its performance. To reinstall the Amplifier, reverse this procedure. Remember to securely tighten cable W3 to the Amplifier output before reinstalling the side panel.

#### 5.2.4 POWER SUPPLY SERVICING

PRINTED CIRCUIT BOARD CONNECTORS - When re-installing a harness connector to the Power Supply printed-circuit board, be sure connector is properly aligned with the board connector pins and that connector faces proper direction (see Figure 5-3).

POWER SUPPLY BOARD REMOVAL - The Power Supply board and heatsink can be removed by removing the four screws which secure the printed circuit board to the instrument rear panel. After removal of the connecting harnesses, the board can be carefully lifted from the instrument.

#### CAUTION

The Power Supply board may be raised far enough to allow

checking of many components with the harnesses still connected; however, power must NOT be applied to the instrument unless the negative (ground) side of C10 is connected to the instrument chassis ground and to the positive (ground) side of C9 (jumper wires are sufficient).

The Power Supply board is reinstalled by reversing the removal procedure.

#### 5.2.5 TRANSISTOR AND IC LEAD CONFIGURATION

Lead configuration is shown in Figure 5-4.

#### 5.2.6 RECOMMENDED TEST EQUIPMENT

The test equipment shown in Table 4-1 is recommended for servicing, troubleshooting and calibrating the Wavetek Model 2002A.

#### 5.3 CALIBRATION PROCEDURE

The following procedure assumes the instrument is equipped with the A3 Deluxe Harmonic Marker option. Calibration by using an external marker generator and other marker options is possible; however, a complete calibration by this method is extremely inefficient.

Figure 5-4. Component Lead Configuration

Remove top and bottom covers. The instrument is calibrated using the module extender from the service kit. Allow a half-hour warm-up before calibrating.

In general, calibration should be performed in the sequence given.

#### 5.3.1 POWER SUPPLY CHECK AND ADJUSTMENT

The Power Supply provides +27 VDC (unregulated), and three regulated DC voltages, +18 V, -18 V, and +7 V to the instrument. The performance of the Power Supply can conveniently be checked by measuring the values at J2. (See Figure 5-22 and Table 5-1.)

The Power Supply also supplies a 20 VAC signal on pin 8 of J2 which is used to trigger the sweep rate circuit when the SWEEP TIME control is set to LINE.

A separate +20 V supply is used to the supply DC voltage to the MA111 Output Amplifier. It is located on the under side of the chassis as shown in Figure 5-23.

Adjust the +20 volt control to provide +20.0 volts at the indicated point in Figure 5-23. Typical peak-to-peak ripple is <10 mV.

# MAINTENANCE

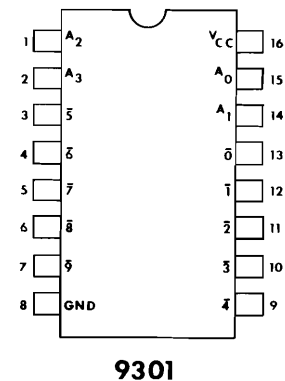
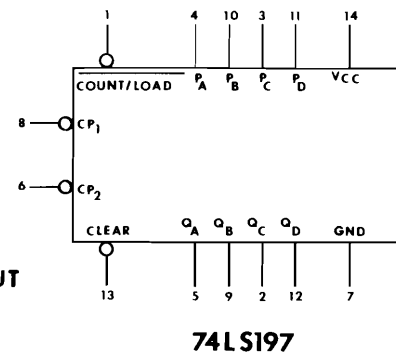
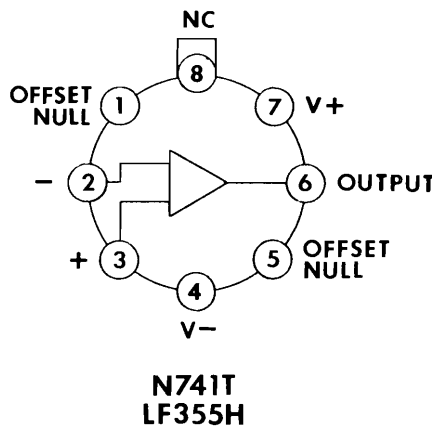
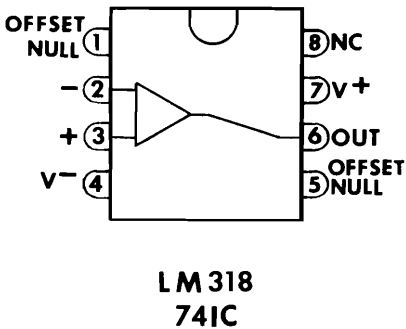
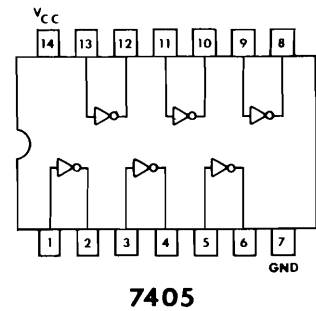
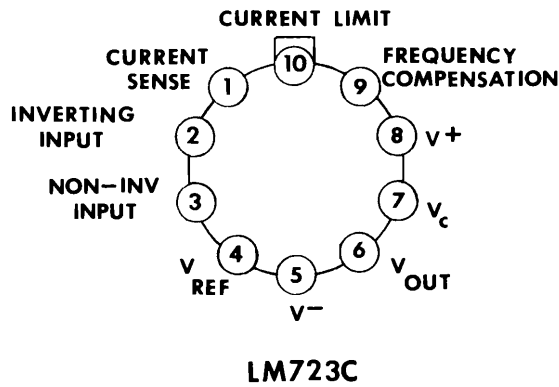
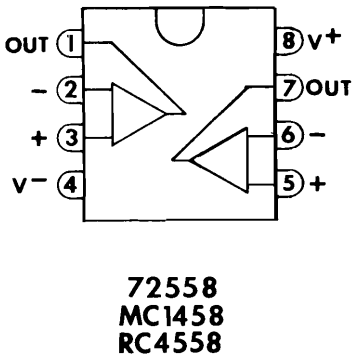
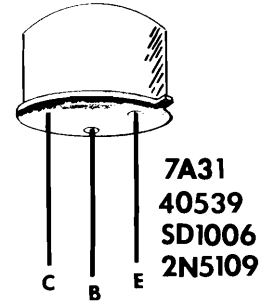
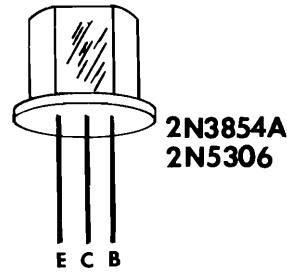
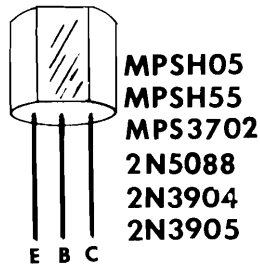
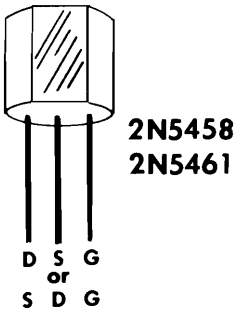
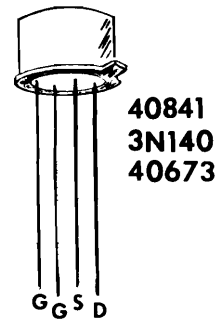
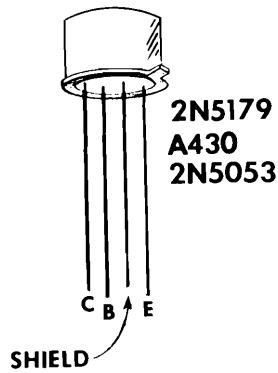
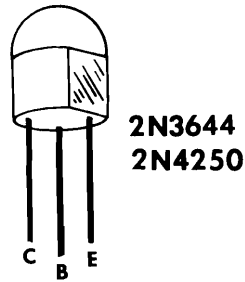
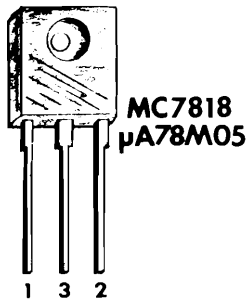

Figure 5-4. Component Lead Configuration

TABLE 5-1. J2 PIN VALUES

J2 PIN	SUPPLY	VOLTAGE & TOLERANCE	TYPICAL TO-PEAK	PEAK-RIPPLE
1	+27	+28 ±1*	1.5V	
2 & 3	+18	+18.00 ADJ	.5 mV	
4 & 5	-18	-18.00 ADJ	.5 mV	
6	NC			
7	+7	7.5±.2	.5 mV	
8	20 VAC	-----	-----	
9	COMMON	COMMON	-----	

\*With input 115 VAC

### 5.3.2 SWEEP RATE ADJUSTMENT AND CHECKS

The sweep rate circuit consists of module M101B and associated front-panel controls. It provides the basic ramp from which the horizontal output and sweep drive signals are derived, plus the RF blanking signal and a precision ±10 V supply. The following procedure checks and calibrates the sweep rate circuit.

#### DISASSEMBLY PROCEDURE

Remove the screw from the top of module M101B and lift cover off. Figure 5-5 shows the location of the M101B adjustments. Figure 5-6 shown the associated front-panel controls.

#### FREQ ADJUSTMENTS

Set the instrument control as follows:

MODE	ΔF
BAND	1
SWEEPTIME	.01 - .1
VAR/MANUAL	full cw
TRIG/RECUR	RECUR
BLANKING	ON
SWEEP DWELL	OFF

Connect the oscilloscope's vertical input to the HORIZ OUT connector on the instrument front panel. Adjust the oscilloscope's sensitivity, position, and time base controls to produce a stable pattern similar to Figure 5-7. Adjust the Freq adjustment in the M101B module to produce a sweep time of ≤10 msec. Set the MANUAL control fully counterclockwise and check the sweep time. It must be longer than 110 msec.

### WAIT TIME ADJUSTMENT

Set the instrument controls as follows:

MODE	ΔF
BAND	2
SWEEP TIME	LINE
VAR/MANUAL	N/A
TRIG/RECUR	RECUR
BLANKING	ON
SWEEP DWELL	OFF
CENT FREQ	1000 MHz
SWEEP WIDTH	500 MHz

The scope should show a triangle wave with a delay of approximately 1 msec in approximately the center of both the rise and fall of the waveform (see Figure 5-7). These delays are due to band switching discontinuities. Adjust the Wait control (located on the rear of the SWEEP TIME switch - see Figure 5-22) to produce a 1 msec delay at the bottom of the triangle (see Figure 5-8).

Set the BAND switch to 1. The wait time at the bottom of the triangle should be approximately 3 msec with no delays due to band switching discontinuities. The same should be true when the BAND switch is set to 3.

Set the BAND switch to 4. The rise and fall times of the triangle should be approximately twice as long as they were on Band 2, thus the repetition rate is half the line frequency. The wait time should vary from approximately 1 to 7 msec, depending upon the number of band switching discontinuity delays present as the CENT FREQ and SWEEP WIDTH control settings are varied.

#### MANUAL LIMIT ADJUSTMENT

Set the front-panel SWEEP TIME selector to its MANUAL POSITION. Set the scope's horizontal trigger control for line rate. Set the VAR/MANUAL control fully clockwise and adjust the Manual Limit control on the M101B to produce a DC voltage exactly equal to the peak amplitude of the horizontal output as read in Figure 5-7 or 5-8 (approximately +10 V).

#### SWEEP DWELL

Set the BAND switch to 4 and turn the rear-panel SWEEP DWELL switch on. The wait time at the bottom of the triangle should increase by approximately 4 msec. The fall time of the triangle wave should decrease, thus the repetition rate of the sweep remains at half the line frequency.

Set the BAND switch to 1, 2, or 3. The rise and fall times of the triangle wave should be the same as they were

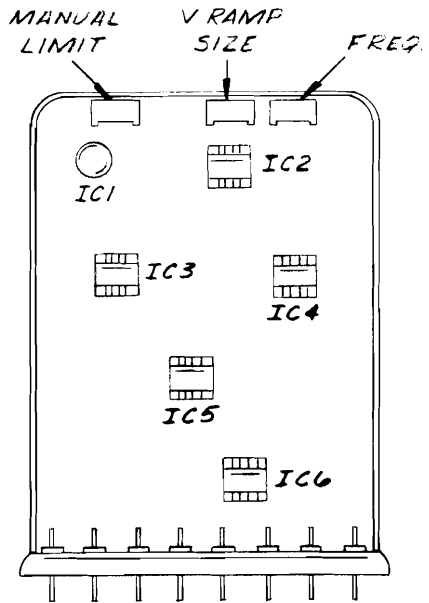

Figure 5-5. M101B Adjustments

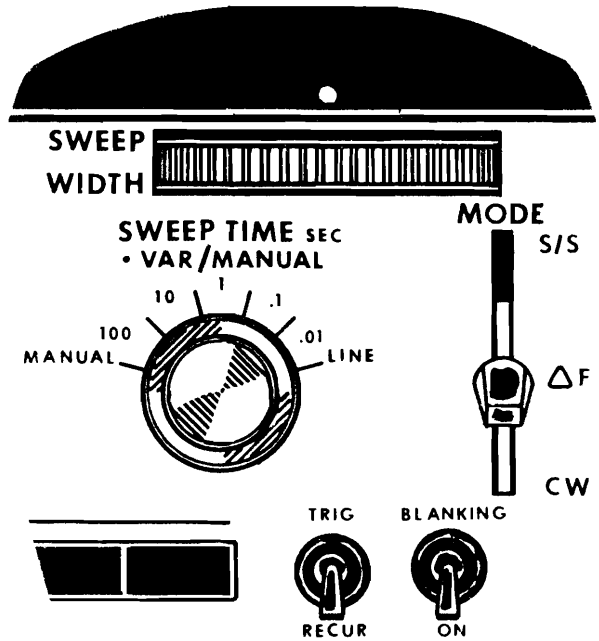

Figure 5-6. Sweep Time Controls (F.P.)

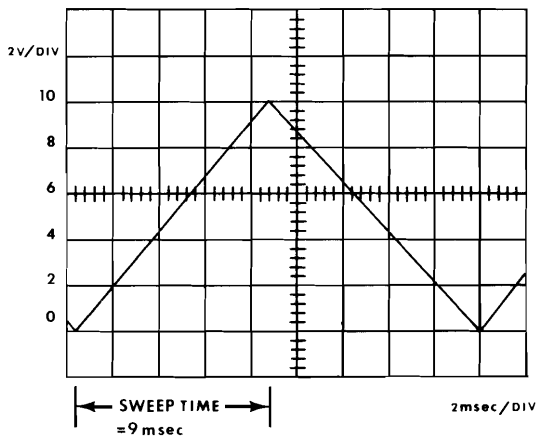

Figure 5-7. Frequency Adjustment

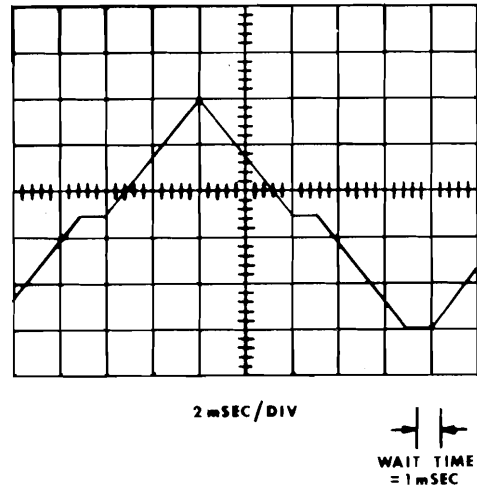

Figure 5-8. Wait Time Adjustment

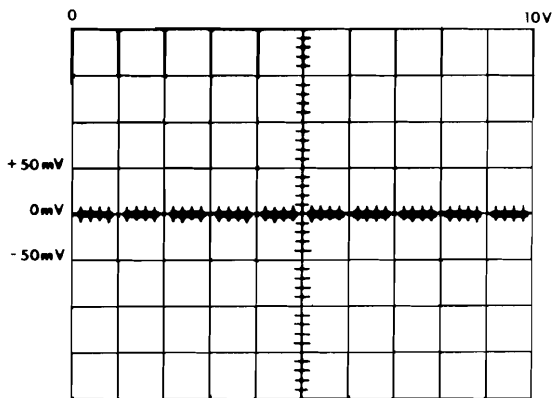

Figure 5-9. Ramp Size Adjustment

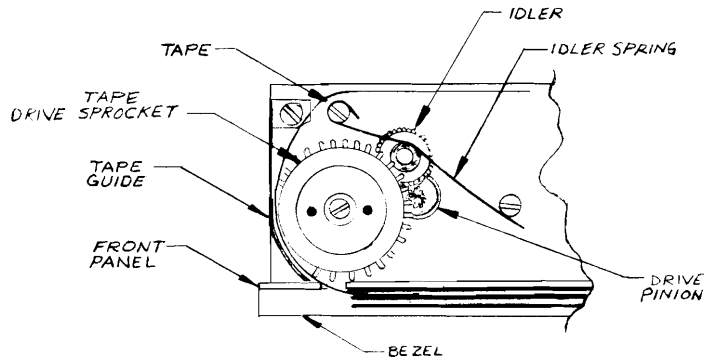

Figure 5-10. Tape Drive



previously, but the wait time will increase by approximately 4 msec, thus cutting the repetition rate in half due to the wait time overlapping the line trigger pulse.

#### PRECISION $\pm 10$ V SUPPLY CHECK

In order to maintain the accuracy of the FREQUENCY SCALE in the S/S,  $\Delta F$  and CW modes of operation, the  $\pm 10$  V supplies, the standard-sweep ramp, and the inverted sweep ramp must maintain precise relationships with each other. These relationships are maintained by precision resistors and a single potentiometer (V Ramp Size) located in the M101B module. The following procedure checks these relationships and provides a high-resolution method of calibrating the inverted ramp size.

Connect the DVM to pin 7 of the M131 module. Set the BAND switch to 1, the MODE switch to CW, and the CENTER FREQ control against its mechanical stop at the low end of the FREQUENCY SCALE. Record the voltage read on the DVM to three decimal places. Set the CENTER FREQ control against its mechanical stop at the high end of the FREQUENCY SCALE. Compare this voltage (ignoring polarity) to the previously read voltage. The difference should be less than 10 mV.

#### RAMP SIZE CHECK

Set the instrument controls as follows:

BAND	1
SWEEP TIME	LINE
MODE	$\Delta F$

CENTER FREQ and SWEEP WIDTH controls set against their mechanical stops at the high end of the FREQUENCY SCALE.

Connect the instrument HORIZ OUT connector to the oscilloscope's horizontal input. Adjust the oscilloscope to operate in an X-Y mode with its horizontal sensitivity set to 1 volt per division and the vertical sensitivity set to 50 millivolts per division. Center the trace on the scope with the position controls as shown in the dashed line of Figure 5-9. Connect the oscilloscope's vertical input to pin 7 of the M131 module. Set the SWEEP TIME selector to the 1 - 10 sec position and the VAR MANUAL control fully clockwise. (This slow sweep is necessary to prevent scope errors due to overdriving.) A trace with a repetition rate of 1 second should appear at the left side of the scope display (see Figure 5-9). The end of the scope trace should be 0 volts  $\pm 70$  mV measured on the vertical axis. Do not change the setting of the SWEEP WIDTH control, but set the CENT FREQ control against its mechanical stop at the low frequency end of the FREQUENCY SCALE. The end of the scope trace should now be at the right side of the display (Figure 5-9) and again have an amplitude of 0 V  $\pm 70$  mV.

#### INVERTED RAMP SIZE (V RAMP SIZE)

Remove the vertical input to the oscilloscope. Set the SWEEP TIME to MANUAL. Adjust the VAR/MANUAL sweep time control to position the dot to the exact center of the oscilloscope display. Set the MODE switch to CW and both CENT FREQ and SWEEP WIDTH controls against their mechanical stops at the high end of the FREQUENCY SCALE.

Connect the DVM to pin 7 of the M131 module and record the voltage to three decimal places. Set the MODE switch to S/S and compare the DVM reading to the previously recorded voltage. The difference should be less than 35 mV. Record the second voltage to three decimal places. Rotate the VAR/ MANUAL control to its extreme counterclockwise position. Adjust the V Ramp Size control in module M101B (see Figure 5-5) to obtain the same exact voltage. Rotating the VAR/MANUAL control through its entire range should not change the DVM reading. Replace the cover on the M101B module.

This procedure ensures the frequency error produced by module M101B will be less than 3 MHz.

#### 5.3.3 FREQUENCY ADJUSTMENT

##### MECHANICAL ADJUSTMENT OF FREQUENCY INDICATOR TAPE

Rotate both START and STOP thumbwheels to their lowest frequency positions at the mechanical stops. Both frequency indicators must read 0 MHz  $\pm 2$  MHz when read on the Sweep Width FREQUENCY SCALE: if not, proceed as follows: With reference to Figure 5-10, disengage Idler by forcing Idler Spring to a disengaged position. While Idler is disengaged, rotate the Tape Drive Gear until the frequency indicator indicates zero frequency. Release the Idler Spring and engage the Idler. If the frequency error is still more than 2 MHz, loosen the screw holding the Tape Guide and Rotate the Guide so the Tape can be disengaged from the sprockets on the Tape Drive Gear. Disengage the Tape from the Tape Drive Gear sprockets and advance the tape one sprocket in the opposite direction of the frequency error. Engage the Tape on the sprocket, reposition the Tape Guide and tighten the screw. Again disengage the Idler and turn the Tape Drive Gear to indicate zero frequency. The front-panel CENT FREQ/START control thumbwheel must be held against its mechanical stop during the entire adjustment procedure.

##### OSCILLOSCOPE LINEARITY CHECK

Before making the following electrical adjustment, first check the horizontal linearity of the oscilloscope, since any oscilloscope linearity errors will be added to the linearity adjustment error.

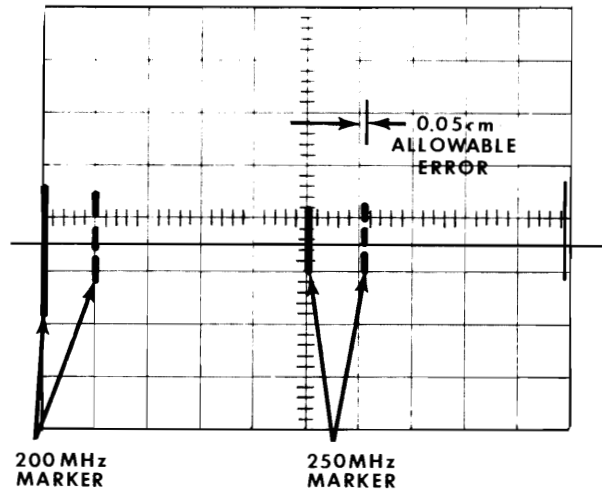

Figure 5-11. Scope Linearility Check

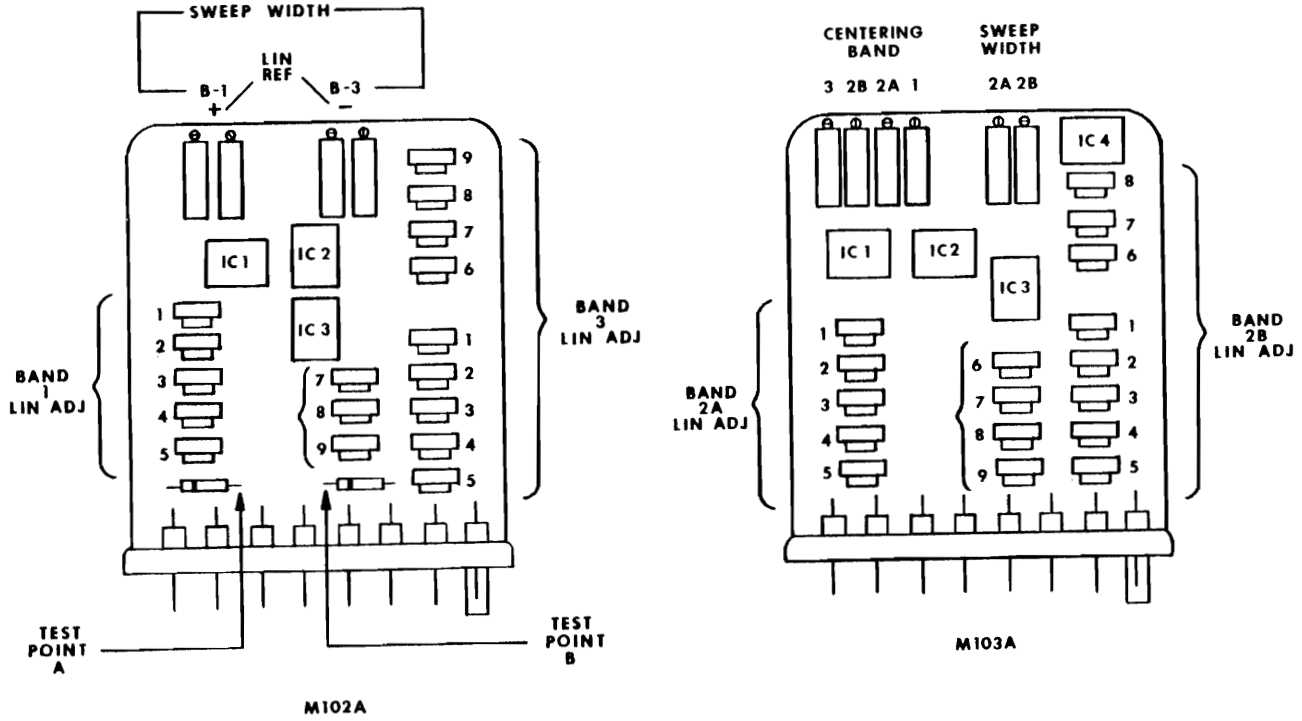

Figure 5-12. Sweep Drive Adjustments

Adjust the oscilloscope to operate in an X-Y mode and set the horizontal and vertical sensitivities to 1 V/division. Connect the instrument HORIZ OUT connector to the oscilloscope's horizontal input, and the VERT OUT connector to the oscilloscope's vertical input. The scope inputs should be DC coupled.

Set the instrument controls as follows:

BAND	1
MODE	$\Delta F$
CENT FREQ	250 MHz
SWEEP WIDTH	100 MHz
SWEEP TIME	LINE
HARMONIC MARKERS	50 MHz

Adjust the oscilloscope's horizontal position and sensitivity controls for a horizontal line that over-travels the scope graticule approximately 0.5 division on both ends (see Figure 5-11). Adjust the MARKER WIDTH for a display width that slightly overlaps the width of a graticule line. Fine adjust the CENT FREQ and SWEEP WIDTH controls until the 200 MHz marker exactly coincides with the extreme left graticule line and the 250 MHz marker exactly coincides with the center line of the scope graticule as shown in Figure 5-11. Disregard the position of the 300 MHz marker. Adjust only the CENT FREQ control until the 200 MHz marker coincides with the graticule line one division from the extreme left. The 250 MHz marker should coincide with the first graticule line to the right of center within  $\pm 0.25$  minor division. Continue to adjust only the CENT FREQ control to position markers at one division intervals until the 200 MHz marker coincides with the graticule center line.

The 250 MHz marker should coincide with its corresponding graticule line within  $\pm 0.25$  minor divisions at all five check points across the display.

The 0.25 minor division error (50 mV) is equivalent to a 0.5% linearity error. This error can be eliminated by using the same scope for calibration and operation.

#### ELECTRICAL FREQUENCY ADJUSTMENTS

Electrical frequency adjustments are located in modules M131, M102A and M103A. In order to access the controls in these modules, the module being adjusted should be set up on a module entender (part of Service Kit K004) with the module cover removed.

#### LINEARITY REFERENCE ADJUSTMENT

Set the instrument controls as follows:

BAND	1
MODE	$\Delta F$
CENT FREQ	exactly 250 MHz

SWEEP WIDTH	exactly 500 MHz
SWEEP TIME	LINE

Adjust the oscilloscope to operate in an X-Y mode and set the horizontal and vertical sensitivities to 1 V/division. Connect the instrument HORIZ OUT connector to the oscilloscope's horizontal input and position the trace as shown in Figure 5-13. The scope trace must be exactly 10 divisions long, starting exactly on the extreme left graticule line and ending exactly on the extreme right graticule line. Adjust the oscilloscope's horizontal sensitivity and position controls as necessary. Connect the oscilloscope's vertical input to Test Point A (see Figure 5-12) of module M102A.

Adjust the + Lin Ref Control to position the "knee" exactly one division from the extreme right side of the display (see Figure 5-13). Next, connect the oscilloscope's vertical input to Test Point B and adjust the - Lin Ref control to position the "knee" exactly one division from the extreme left side of the display (see Figure 5-13).

#### CENTER FREQUENCY ADJUSTMENT

Set the instrument controls as follows:

BAND	1
MODE	$\Delta F$
CENT FREQ	exactly 250 MHz
SWEEP WIDTH	10 MHz
SWEEP TIME	LINE
HARMONIC MARKERS	50 MHz

Adjust the oscilloscope to operate in an X-Y mode and set the horizontal and vertical sensitivities to 1 V/division. Connect the instrument HORIZ OUT connector to the oscilloscope's horizontal input and center the horizontal trace on the scope.

Connect the instrument's VERT OUT connector to the oscilloscope's vertical input and adjust the MARKER SIZE and WIDTH controls for a display similar to that shown in Figure 5-14. If no marker is visible on the display, increase the SWEEP WIDTH control until a small marker is present on the display. (The operation is such that odd harmonics of 50 MHz will have a smaller amplitude than even harmonics. Since the center frequencies of bands 1, 2A, and 2B are odd harmonics, they will have a smaller amplitude, while the center frequency of band 3 is an even harmonic and will have a larger marker amplitude.) This procedure will work if the center frequency error is less than 100 MHz. If the center frequency error is more than 100 MHz, an external marker must be used to identify the correct 50 MHz harmonic. The external marker generator's frequency can be at the center frequency or at a subharmonic. For example, the band 3 center frequency is 2000 MHz, so the external marker frequency can be 2000, 1000, or 500 MHz. The external marker circuit will produce harmonics of the input signal to 2000 MHz.

Figure 5-13.  
Linearity Reference  
Adjustment

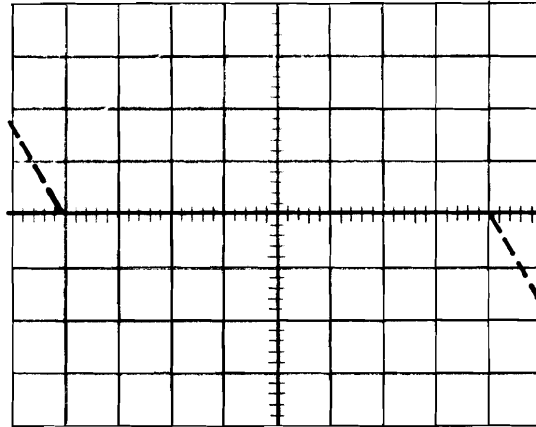

Figure 5-14.  
Centering

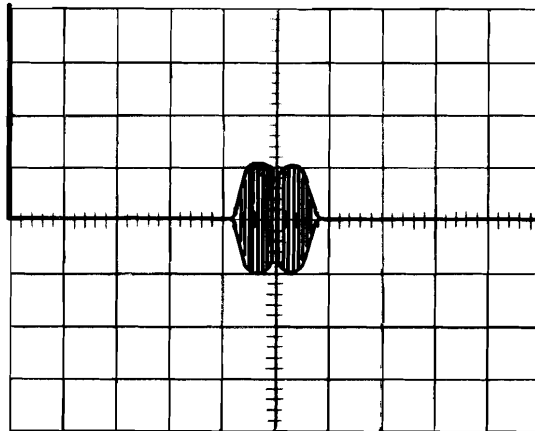
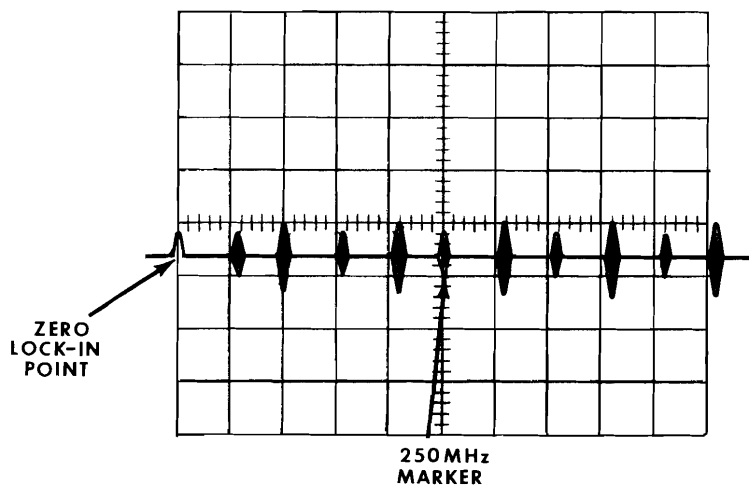

Figure 5-15.  
Display Calibration



### CENTERING BAND 1

With the M103A Centering Band 1 control (see Figure 5-12) adjust the 250 MHz marker to the center of the display as shown in Figure 5-14. Decrease the sweep width to <10 MHz before completing the adjustment.

### CENTERING BAND 2

This will be covered in the Linearity Adjustment (Band 2) Section below.

### CENTERING BAND 3

Set the BAND switch to 3 and center the 2000 MHz marker on the display with the Centering Band 3 control. Without touching other controls, switch between bands 1 and 3 and verify that each marker is centered.

### ADJUSTMENT OF 0 MHz LOCK-IN POINT

Set the instrument controls as follows:

BAND	1
MODE	$\Delta F$
CENT FREQ	0 MHz
SWEEP WIDTH	10 MHz

Adjust the M102A Sweep Width Band 1 control (see Figure 5-12) to position the 0 MHz lock-in point to the exact center of the display.

Set the instrument controls as follows:

BAND	1
MODE	$\Delta F$
CENT FREQ	exactly 250 MHz
SWEEP WIDTH	530 MHz
SWEEP TIME	LINE
HARMONIC MARKER	50 MHz

With the oscilloscope's horizontal position and sensitivity controls, superimpose the 0 MHz lock-in point exactly on the extreme left graticule line and the 250 MHz marker exactly on the center line of the scope graticule. (Disregard location of all other markers.) See Figure 5-15.

### LINEARITY ADJUSTMENT (BANDS 1 AND 3)

Being careful not to disturb the oscilloscope's position and sensitivity controls, readjust the M102A Sweep Width Band 1 control to superimpose the 150 MHz marker exactly on the scope graticule line as shown in Figure 5-16. Proceed to adjust Band 1 Lin 1 through 9 controls in Module M102A

(Figure 5-12) to position each marker as shown in Figure 5-16. (There is no Lin 6 control for Band 1.) The adjustment procedure must be done in the sequence given.

Each of the eleven markers in the display must be aligned within  $\pm 1$  full division of its vertical graticule line to provide the maximum specified linearity error of 1%.

Set the MODE switch to S/S and adjust the START and STOP controls to exactly duplicate the display shown in Figure 5-16.

Change to band 3.

Turn on the 100 MHz markers. Check the position of the 2000 MHz marker. Adjust the Sweep Width Band 3 and Linearity controls (Lin 1 through 9) to position the markers as shown in Figure 5-16. (Use the Sweep Width Band 3 control to set the 1900 MHz marker.)

While observing the oscilloscope display, switch between bands 1 and 3 without adjusting any other controls. There should be a negligible shift in marker location on the display.

Set the oscilloscope's vertical sensitivity control for 5 V/division and connect the oscilloscope's vertical input to pin 7 of the M131 module.

### LINEARITY ADJUSTMENT (BAND 2)

Set the BAND switch to 2. With the oscilloscope's vertical input still connected to pin 7 of the M131 module, adjust R36 in the M131 to position the band 2A portion of the ramp such that it crosses 0 V exactly 2.5 divisions in from the extreme left graticule (see Figure 5-17). Adjust R42 such that the band 2B portion crosses 0 V exactly 2.5 divisions in from the extreme right graticule. Turn on the 50 MHz markers and connect the oscilloscope's vertical input to the instrument's SCOPE VERT connector. Using the M103A Cent 2A control, position the 750 MHz marker exactly 2.5 divisions in from the extreme left graticule. Using the Sweep Width 2A control, position the 700 MHz marker exactly 2 divisions in from the extreme left graticule. Adjust the Band 2A Lin Adj controls to position the other markers at 0.5 division intervals (see Table 5-2).

Using the M103A Cent 2B control, position the 1250 MHz marker exactly 2.5 divisions in from the extreme right graticule. Using the Sweep Width 2B control, position the 1200 MHz marker exactly 3 divisions in from the extreme right graticule. Adjust the Band 2B Lin Adj controls to position the other markers at 0.5 division intervals (see Table 5-2 and Figure 5-17).

Figure 5-16.  
Linearity Adjustments,  
Bands 1 And 3

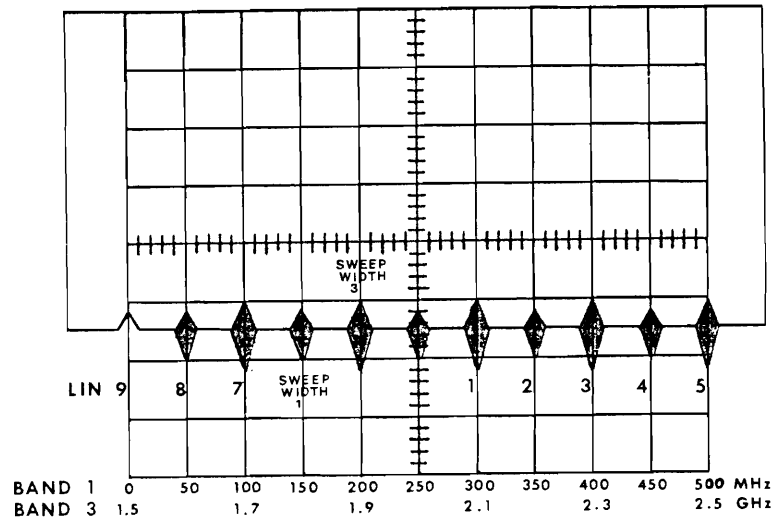

Figure 5-17.  
Linearity Adjustments,  
Band 2

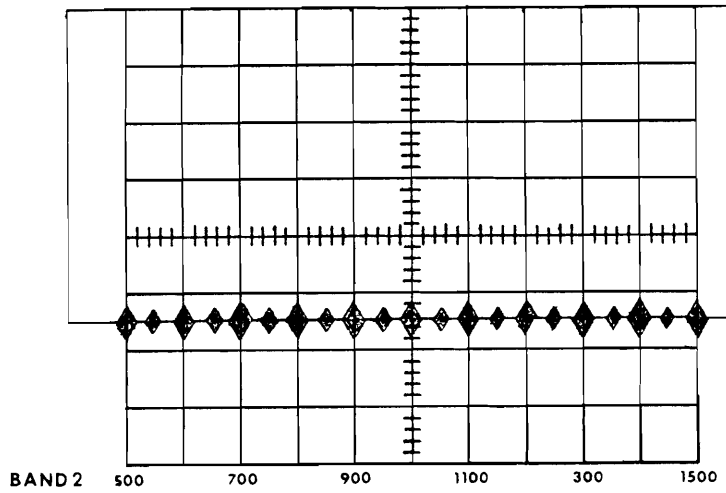
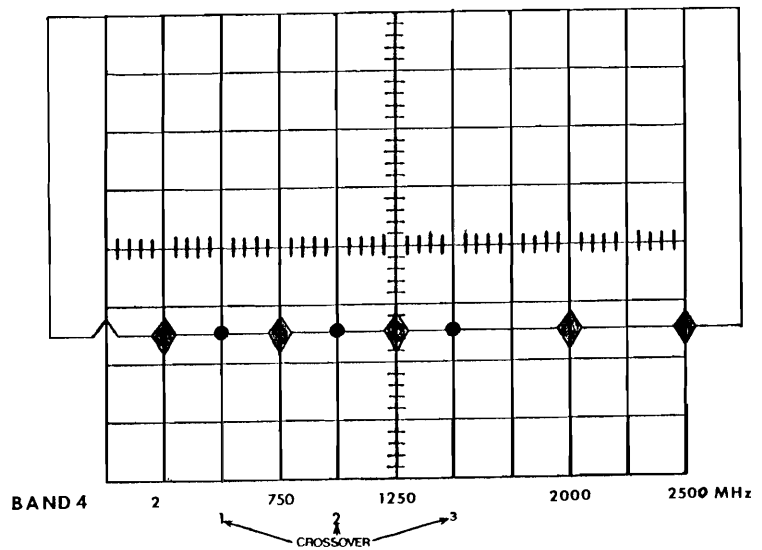

Figure 5-18.  
Linearity Adjustments,  
Band 4



**TABLE 5.2. BAND 2 LINEARITY ADJUSTMENT**

(Adjust controls in order given.)

BAND A		BAND B	
CTL	MKR (MHz)	CTL	MKR (MHz)
1	800	1	1300
2	850	2	1350
3	900	3	1400
4	950	4	1450
5	000	5	1500
6	650	6	1100
7	600	7	1050
8	550	8	1000
9	500		

Replace the covers on modules M102A and M103A.

**BAND 4 SET-UP**

Set up of band 4 is a special case since this is a stacked band made up of four individual oscillators which have already been set up for linearity.

All controls for setting up band 4 are located in module M131 (see Figure 5-19). These controls act to break the basic ramp from the M101B rate generator into 4 sequential 10 V ramps before it is applied to the shaping circuits.

Place the front-panel BAND switch to 4, leaving the other front-panel controls and scope settings as they were for the Band 3 linearity adjustments. Using R57 in the M131, set the first crossover point approximately 2 divisions in from the extreme left graticule. Use R60 to set the second crossover 4 divisions in from the extreme left graticule and R64 to set the last crossover 6 divisions in from the extreme left graticule. These settings are approximate, and the crossover points may be moved slightly during the rest of this set-up to examine any oscillator at the point of crossover. Final setting of these crossover points will be covered in the next section. The reason for making these preliminary settings is to ensure that all four oscillators are activated in their appropriate sequence (see Figure 5-18).

Using R34, adjust the 250 MHz marker to fall precisely one division in from the extreme left graticule. (This must be the first centering control adjusted, as it affects the centering of all four oscillators.) Using R45, adjust the 750 MHz marker to be precisely on the 3rd graticule in from the oscilloscope's far left graticule. (To identify markers on bands other than band one, use the MARKER IN connector in conjunction with an external source.) Adjust R44 such that the 1250 MHz marker falls exactly on the center graticule of the scope. Adjust R40 such that the 2000 MHz marker falls on the second graticule in from the extreme right scope graticule. The four oscillators should

now be centered in their respective positions.

All that remains is to set the sweep widths of the oscillators such that the 500 MHz harmonics (500, 1000, 1500) fall at the crossover points.

In setting the sweep widths, R17 must be adjusted first, as it affects all four oscillators. R17 adjusts the sweep width of the band 3 oscillator (1500-2500 MHz). To adjust, first move the last crossover point (with R64) slightly to the left of it's normal position (1 division to right of scope center), then adjust R17 to position the 1500 MHz marker from the band 3 oscillator on (or very slightly to the right of) the first graticule to the right of scope center.

R18 adjusts the sweep widths of the oscillators for bands 1, 2A, and 2B simultaneously. Adjust R18 to almost superimpose the 500 MHz marker from band 1 on the 500 MHz marker from band two (these markers can be seen simultaneously if the BLANKING switch on the front panel is turned off, since the crossover point on the retrace occurs at a lower frequency than it does during forward sweep).

If all of the aforementioned adjustments are properly made, there should be less than 20 MHz overlap of frequencies at any crossover point. The next section details the procedure for checking the overlap and making the final settings of the crossover points.

**CROSSOVER ADJUSTMENT**

Set the BAND switch to 4. Adjust R57 in module M131 such that the first crossover point (500 MHz) on the forward sweep (not the retrace) is exactly 2 divisions in from the left edge of the display. Adjust R60 such that the second crossover point (1000 MHz) is exactly 4 divisions in from the left edge of the display. Adjust R64 such that the third crossover point (1500 MHz) is exactly 6 divisions in from the left edge of the display.

After adjusting the crossover points, set the START and STOP controls such that the 450 MHz marker falls on the far left vertical graticule and the 550 MHz marker falls on the far right vertical graticule. Turn on the 10 MHz markers, and identify each marker by counting from the 450 MHz and 550 MHz markers toward the center of the display. (Do not count past the crossover point from either direction.) Adjust R57 in module M131 such that the crossover point is just to the left of the 500 MHz marker from the higher band (see Figure 5-18). The marker to the left of the crossover point should be 490, 500, or 510 MHz from the lower band. If it is not, adjust.

**NOTE**

**The exact frequency of the crossover point is not critical; however, the crossover "overlap" specification of +20-9 MHz should be maintained.**

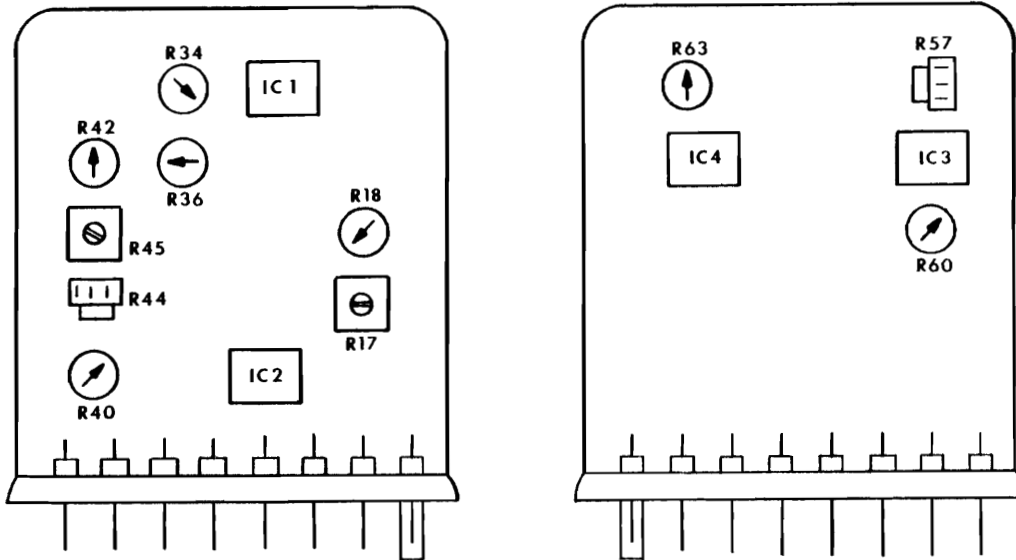

Figure 5-19. M131 Adjustments

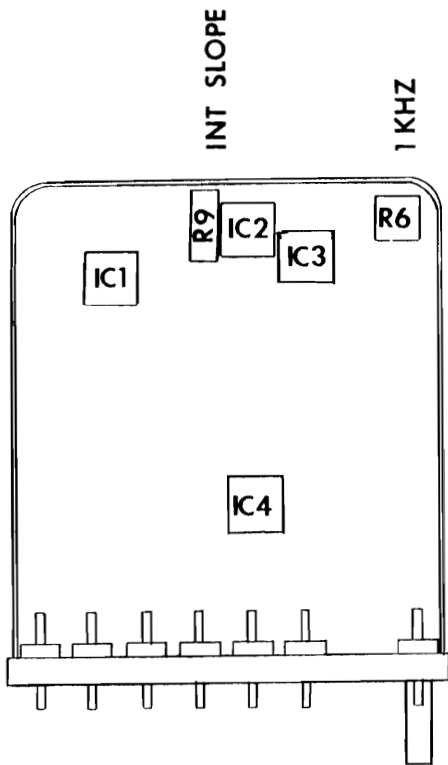

Figure 5-20. M104A Adjustments

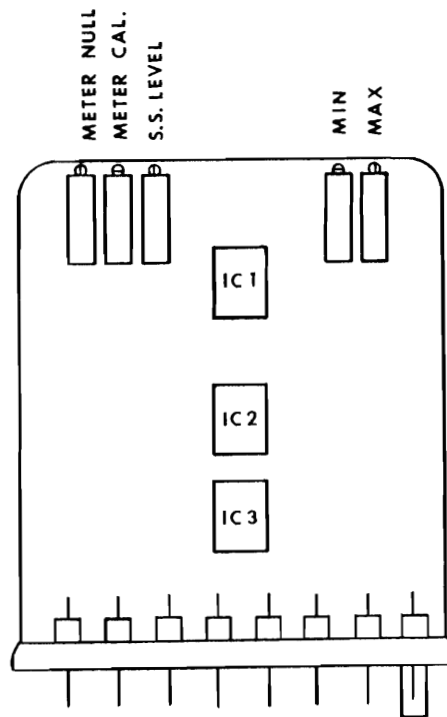

Figure 5-21. M121 Adjustments



Repeat the above procedure using the corresponding frequencies and controls for the 1000 and 1500 MHz cross-over points.

Carefully replace the cover on the M131 module.

### 5.3.4 LEVEL ADJUSTMENT

The leveler adjustments and the output METER calibrator are located in modules M104A and M121. Remove the covers from these modules.

### SLOPE ADJUSTMENTS

The Model 2002A has two slope adjustments. The internal Slope control is factory set to compensate for any roll-off of amplitude due to components. The front-panel SLOPE control is for customer use to compensate for any roll-off due to interconnections. This slope is detectable on the output meter at slow sweep speeds, but since the purpose of the internal Slope is to assure a flat output, this slope is nulled out at the METER by the following procedure.

Set the Model 2002A for a sweep time of .01 seconds, sweeping from 1 to 2500 MHz (band 4, S/S). Connect the oscilloscope vertical input to pin 12 of the M121 module and adjust the internal Slope control (R9 of the M121) for zero slope. Connect the oscilloscope vertical input to pin 10 of the M121. Any slope showing at this point is now due entirely to the external scope control. Adjust the front-panel SLOPE control to obtain zero slope at this point. Now readjust the internal Slope control in the M121 to obtain the maximum slope. This slope is now due entirely to the internal slope. Set the front-panel SWEEP RATE control to MANUAL and rotate the VAR/MANUAL control throughout its range. The METER may show some deflection as the unit is swept manually. If it does, turn the VAR/MANUAL control fully cw and adjust the Meter Null control (R11 in the M104A) to bring the METER reading back towards its position when the VAR/MANUAL control is fully ccw.

It may be necessary to manually sweep the unit back and forth through its range several times while this adjustment is being made. Continue adjusting until the METER shows no perceptible deflection as the unit is manually swept through its range. The internal slope is now nulled out and will not show perceptibly on the METER.

Switch the front-panel SWEEP RATE switch back to the .01 sec position and readjust the internal Slope control to obtain a flat output.

### METER CAL

With AC power turned off, check position of the METER pointer. It should be positioned over the dot at the

extreme left end of the METER scale. If not, the METER's mechanical zero must be readjusted.

Remove the two screws from the METER mounting bracket located on the back of the front panel. Remove the METER from the front panel. The METER's zero adjustment is now accessible, and can be adjusted for proper zero position. Reinstall the METER.

Turn AC power on and adjust the front-panel OUTPUT VERNIER control to the maximum clockwise position. Adjust the M104A Meter Cal control (see Figure 5-20) to superimpose the METER pointer over the +3 dBm mark at the extreme right side of the scale.

### SWEEP SAMPLE LEVEL ADJUST

Referring to Figure 5-22, disconnect cable W5 from the MA111 Output Amplifier. Connect the power meter's sensor to this sweep sample connector. Necessary coax adapters to connect the power sensor (type N) to the sweep sample connector (type SMC) are available as part of the K005 Service Kit. Adjust the Model 2002A controls as follows:

BAND	1
MODE	S/S
START	0 MHz
STOP	500 MHz
SWEEP TIME	MANUAL

Rotate the VAR/MANUAL control to its center position and adjust the sweep sample SS Level control (R2) in module M104A (Figure 5-20) to obtain a power meter reading of -10 dBm. Rotate the VAR/MANUAL control through its entire range. The minimum and maximum readings must be between -8 and -12 dBm. Repeat this check for bands 2 and 3. Disconnect the adapters and reconnect cable W5 to Output Amplifier MA111.

### OUTPUT LEVEL MIN AND MAX ADJUST

Adjust the Model 2002A controls as follows:

BAND	1
MODE	CW
CENT FREQ	250 MHz
OUTPUT STEP	+10 dBm
OUTPUT VERNIER	full cw

Set the power meter to its +15 dBm range and connect it to the instrument RF OUT connector. Adjust the Level Max control (R12) in module M104A to produce a power meter reading of +13 dBm.

Turn the OUTPUT VERNIER control to indicate -10 dB on the output METER scale. Set the power meter to its 0

dBm scale and adjust the Level Min control (R23) in module M104A to produce a power meter reading of 0 dBm. Since some interaction exists between the Level Max and Min controls, the adjustments must be repeated until the +13 and 0 dBm readings are obtained without further adjustments of the Max and Min controls. The RF output at other frequencies will be checked during Performance Tests (Section 4).

Replace the cover on module M104A.

### 5.3.5 1 KHZ MODULATION FREQ ADJUSTMENT

A single-turn potentiometer on top of module M121 (see Figure 5-22) adjusts the modulation frequency.

### 5.3.6 MARKER SIZE ADJUSTMENT (OPTION A1, A2, AND A3)

Each marker module has a Size adjustment potentiometer which is accessible from the under side of the sweep generator when the bottom cover is removed (see Figure 5-23). The control is adjusted until a saturated marker is obtained on the scope display. A saturated marker is obtained when a further increase in the marker module's Size adjustment does not increase the marker amplitude on the scope display. Increasing the Size adjustment beyond this point will result in spurious markers on the display.

The A3 Deluxe Harmonic Marker option has 4 Marker Size adjustments, one for each marker. They are normally adjusted while operating on band 4. Check all bands and the entire frequency range for proper operation. The A2 Harmonic Marker options are adjusted while operating on band 3, and checked for proper operation on bands 1, 2, and 3 only.

An additional marker size control labeled "Size Ratio", located on top of module M105, is considered an operator control. The Size Ratio control adjusts the ratio of small to full-size markers from approximately 25 to 80%. It is normally adjusted for a 50% ratio (see Section 1.2.5). This control also affects the full-size marker amplitude slightly.

## 5.4 TROUBLESHOOTING

Effective troubleshooting requires a thorough understanding of the block diagrams and circuit description located in Section 3 of this manual. The Performance Tests in Section 4 and Calibration Procedures in Section 5 will aid in localizing the trouble symptom to a particular module or PC board. Once this has been accomplished, the module or board can be replaced or repaired with aid of the proper schematic and parts layout diagram. In general, it is preferable to replace a defective module or PC board assembly.

Equipment troubles are frequently due simply to improper control settings; therefore, before engaging in a troubleshooting procedure, be sure the front-panel controls are set in proper operating position. Refer to the operating instructions in Section 2 of this manual for a complete explanation of each control's function along with typical operating instructions.

After verifying that the trouble is not improper setting of the controls or test setup, make a thorough visual inspection of the instrument for such obvious defects as loose or missing screws, broken wires, defective module-pin sockets, loose RF cables, and burned or broken components.

After localizing the problem, voltage and resistance checks will help find defective components.

For troubleshooting purposes, it is permissible to operate the Model 2002A with any of the plug-in modules or RF cables removed; however, the instrument should be turned off when removing or installing modules. If substitute modules are available, possibly from another Model 2002A, this provides an easy method of verifying if a suspected module is defective.

RF cables can be disconnected from the module output connectors; then, a power meter or spectrum analyzer can be connected directly to the module connector for power level or frequency measurements. Fabrication of a short coax adapter cable, terminated in a mating connector for the modules on one end and a BNC connector on the other, will facilitate connection of test equipment.

A problem in a power supply may cause many symptoms pointing to other areas, and should be checked when the symptom does not indicate a specific problem.

### 5.4.1 TROUBLESHOOTING HINTS

Following is a list of several typical symptoms, accompanied by the possible cause(s) or a troubleshooting procedure. It is assumed the instrument has been properly calibrated previously, and that a warm-up period will precede troubleshooting.

**±18 V OUT OF CALIBRATION** - If the ±18 V supplies measure low, unplug modules until an overload is found.

**INTERMITTENT OPERATION** - Check for loose RF cables or loose modules. If none, check for defective module pin sockets.

**INCORRECT HORIZONTAL OUTPUT** - If horizontal output is incorrect, check module M101B.

**INCORRECT SWEEP RATE** - Check wiring to front-panel SWEEP TIME switch and M101B.

**FREQUENCY UNSTABLE (JITTER)** - Check all modules for loose hold-down screws, especially modules M102A and M103A. Operating the unit in a strong magnetic field, such as setting on top of, or adjacent to, another instrument containing a large power transformer can produce 60 Hz hum modulation.

If all bands are unstable, check for excessive ripple on power supplies.

**NO RF SWEEP** - Check all bands. If none sweep, try the other sweep mode. If still none sweep, check the rear-panel PROGRAMMING plug.

If only one band has no RF sweep, check the appropriate sweep drive signal. If correct, the trouble is probably in the Sweep Oscillator.

**RF OUTPUT NOT FLAT** - Most common cause is the external RF detector being defective. Another is the monitor diode located in the MA111 module. This is a point contact diode and can be damaged if the RF output is momentarily connected to a B+ voltage. A good monitor diode will produce a negative detected voltage (at pin 13 of M104A) approximately twice the amplitude of the external detector. For example, at an RF output of +10 dBm, an external RF detector will read approximately 0.8 V. The internal monitor will read approximately -1.6 V.

**NO RF OUTPUT** - All bands - Defective Attenuator or RF cables connecting to the input or output of the Attenuator. Single band only - if only one band does not work, check for the switched B- voltage at the appropriate module socket as shown on the instrument Wiring Diagram.

## MARKER PROBLEMS

To isolate the cause of a marker problem when the symptom does not clearly indicate a specific circuit or component, first check the sweep sample output at the MA111 Sweep Sample Out connector. It should be a detected signal of between 30 and 50 mV. If the proper sweep sample signal is not present, it indicates that the trouble is in the MA111.

Next, connect the detector in place of the Terminating Plug, P102. A signal at this point indicates all jumper cables and RF jacks on the M6 modules are intact. Check for the birdy output at pin 3 of the marker module. A 10 to 15 mV peak-to-peak birdy is sufficient to drive the M105 module and indicates the M6 module is operating properly. With the 10 mV peak-to-peak birdy present at the input of

the M105 (pins 5, 6, 7, 8, 9), a 20 V peak-to-peak signal will be produced at the output (pin 1). This indicates proper operation of the M105. This output signal at pin 1 is controllable in width by the front-panel MARKER WIDTH control. The signal is now routed through the front-panel MARKER SIZE control to the front-panel VERT OUT connector. A 4 V peak-to-peak signal is normally at this point when the front-panel MARKER SIZE control is set to maximum. A common marker problem occurs when one of the interconnecting cables between the M6 modules is loose. This causes a notch in the sweep sample input to the module, causing uneven harmonics or weak output.

## 5.5 FIELD INSTALLATION OF OPTIONS

All options available on the Model 2002A can be field installed as described below. In each case, refer to Figures 5-22 and 5-23 for locations of sockets, cables, etc. In each case, the top and bottom covers of the instrument must be removed. (For Option B5, only the top cover need be removed.)

### 5.5.1 OPTIONS A1 and A2

Install Options A1 and A2 as follows:

1. Plug the M6 module into the appropriate socket and install the hold-down screw through the instrument chassis.
2. Connect the cable supplied to one of the connectors on top of the module.
3. Remove the Terminating Plug from the M6C or other marker module and install it on the open connector of the M6.
4. Connect the open end of the cable to the connector on which the Terminating Plug had been installed.
5. Replace the blank front-panel pushbutton corresponding to the marker socket used (see Schematic 1B) with the engraved button supplied.
6. Using the test set-up shown in Figure 4-1 (BAND switch set to 2 for harmonic markers, to the appropriate band for single-frequency markers), adjust the Marker Size control, accessible through the instrument chassis, for the correct operating level (see Section 5.3.6).

### NOTE

**If an M66H Dual Harmonic Marker module is to be installed, it will occupy two marker sockets.**

### 5.5.2 OPTION A3

Install Option A3 as follows:

1. Plug the M106 Deluxe Harmonic marker module into the appropriate socket and install the hold-down screw through the instrument chassis.
2. Remove connection cable W5 from the M6C External Marker module and install it on the M106 connector further from the M6C.
3. Connect the cable supplied to the open connectors on the M6C and the M106.
4. Remove the "OPTION NOT INSTALLED" knob from the instrument front panel, and install the new knob supplied.
5. Using the test set-up shown in Figure 4-1 (BAND switch set to 4), adjust the four Marker Size adjustments, accessible through the instrument chassis, for the correct operating levels, i.e. saturated markers (see Section 5.3.6).

### 5.5.3 OPTION B4

Install Option B4 as follows:

1. Remove the binding posts from the mounting bracket of the Pen Lift assembly.
2. Remove the option plate from the instrument rear panel, and remove the two plug buttons from the holes marked "PEN LIFT".
3. Place the mounting bracket against the option plate such that the bracket holes line up with the PEN LIFT holes, and the component side of the bracket will face the instrument power transformer when the option plate is reinstalled.
4. Insert the binding posts through the option plate and mounting bracket from the outside, and secure each using, in order, the shoulder washer, lock washer, and nut provided.
5. Solder each binding post to the wire immediately adjacent to it.
6. Re-install the option plate on the instrument rear panel.
7. Solder the gray wire to pin 10 of the M106 socket.
8. Solder the orange wire to pin 9 of the M106 socket.

### 5.5.4 OPTION B5

Install Option B5 as follows:

1. Remove the Terminating Plug from the M6C or other marker module and connect the Aux RF Out cable to the module connector.
2. Remove the plug button from the rear-panel hole marked "AUX RF OUT".
3. Unscrew the BNC connector body, lockwasher, and backing nut from the Aux RF Out cable.
4. Insert the BNC connector body through the rear-panel AUX RF OUT hole and secure it with the backing nut and lockwasher.
5. Screw the cable into the connector body.
6. Connect the 50 ohm terminator to the BNC connector. When Option B5 is in use, the terminator is removed. When the option is not in use, the terminator must be connected.

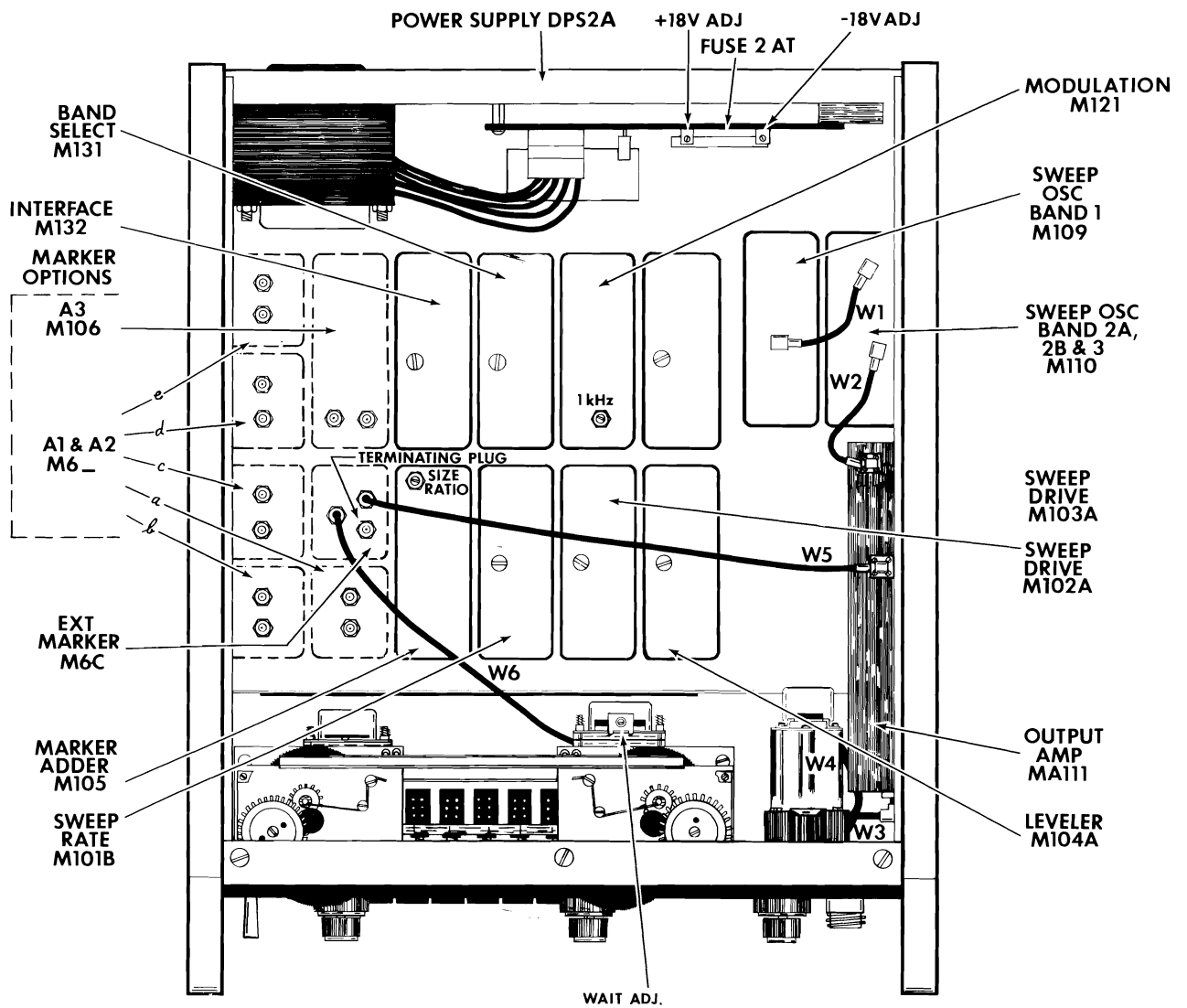

Figure 5-22. Top View

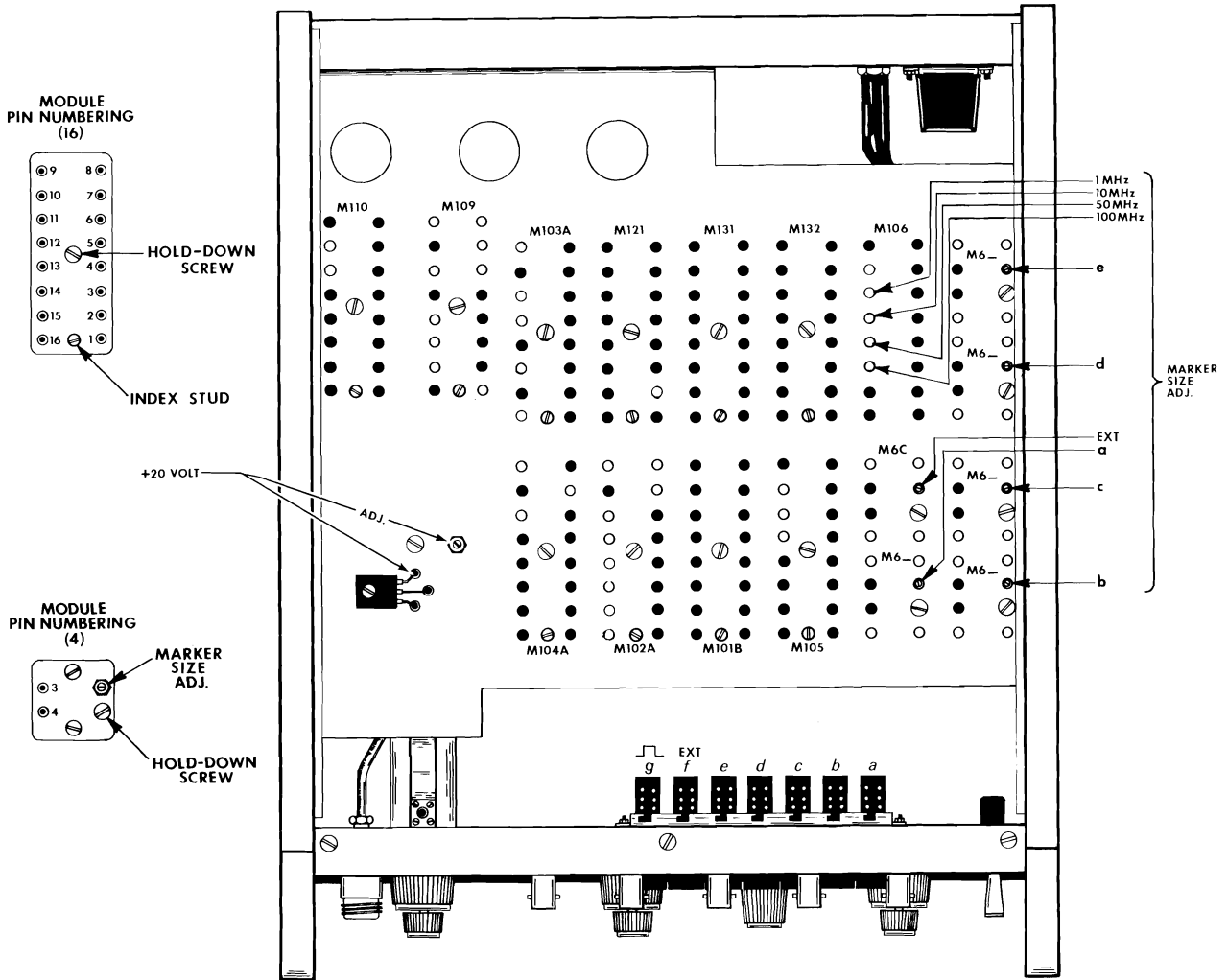

Figure 5-23. Bottom View

# SECTION 6

## REPLACEABLE PARTS

### 6.1 INTRODUCTION

This section contains lists of all replaceable parts for the instrument.

For an assembly containing one or more subassemblies, the assembly list appears first, and is followed by the subassembly lists.

The lists appear in the following order.

PARTS LIST	ASSEMBLY
1010-00-0141	2002A
1111-00-0083	CHASSIS
1118-00-0040	REAR PANEL
1219-00-0152	R.P. HARNESS
1118-00-0018	FRONT PANEL
-----	F.P. SUB-ASSY PARTS
1219-00-0150	HARNESS
1118-00-0029	PEN LIFT
1115-00-0011	DPS2A
1218-00-0250	PC – DPS2A
1219-00-0144	LINE CORD – DPS2A
1114-00-0267	M101B
1114-00-0268	M102A
1114-00-0269	M103A
1114-00-0270	M104A
1114-00-0137	M105
1114-00-0138	M109
1219-00-0055	RF MIXER – M109
1219-00-0070	PRE-AMP – M109
1114-00-0139	M110
1118-00-0014	MA111
1218-00-1111	I/O NTWK – MA111
1218-00-1110	I/O NTWK – MA111
1218-00-1100	BIAS CKT – MA111
1114-00-0205	M121
1114-00-0252	M131
1114-00-0251	M132
1114-00-0124	M6C
1114-00-0050	M6H-1
1114-00-0099	M6H-10
1114-00-0100	M6H-50
1114-00-0045	M6S-3
1114-00-0152	M106
1218-00-1180	PC – M106

### 6.2 MANUFACTURERS CODE

The following code is used on the parts lists to identify the manufacturer.

ABBRV	NAME.....	CITY.....	ST
A-B	ALLEN-BRADLEY	MILWAUKEE	WI
A-D	ANALOG DEVICES	CAMBRIDGE	MA
A-H	ARROW HART, INC.	KETTERING	OH
A-I	ALAN INDUSTRIES	COLUMBUS	IN
A-M	AMERICAN MAGNETICS	CARTERVILLE	IL
A-P	AMERICAN PLASTICRAFT CO.	CHICAGO	IL
ABAC	ABACUS PACKAGING CO.	CHICAGO	IL
ACI	ADVANCE COMPONENTS, INC.	CENTERBROOK	CT
AER	AVX CERAMICS	MYRTLE BEACH	SC
AERTK	AERTECH INDUSTRIES	SUNNYVALE	CA
AHAM	AHAM COMPANY	AZUSA	CA
AIN	ALPHA INDUSTRIES, INC.	WOBURN	MA
ALC	ALCO ELECTRONICS PRODUCTS	NORTH ANDOVER	ME
ALLPL	ALL PLASTICS, INC.	INDIANAPOLIS	IN
AMD	ADVANCED MICRO DEVICES INC.	SUNNYVALE	CA
AMD	ADVANCED MICRO DEVICES, INC.	SUNNYVALE	CA
AMELC	AMERICAN ELECTRIC CORDSETS	BENSENVILLE	IL
AMP	AMP, INC.	HARRISBURG	PA
APL	AMPHENOL CONNECTOR SYSTEMS	BROADVIEW	IL
APX	AMPEREX ELECTRONIC CORP.	SLATERSVILLE	RI
ARC	ARCO ELECTRIC PRODUCTS	SHELBYVILLE	IN
ARN	ARNOLD ENGINEERING CO.	MARENGO	IL
ARW-M	ARROW-M CORP.	CARSON	CA
ASC	ASSOCIATED SPRING	BRISTOL	CT
ASE	AIRCO SPEER ELECTRONICS	ST. MARYS	PA
AT/IN	ATLANTIC INDIA RUBBER COMPANY	CHICAGO	IL
ATC	AMERICAN TECHNICAL CERAMICS	HUNTINGTON STATION	NY
ATR	ATR COIL CO.	BLOOMINGTON	IN
AUGAT	AUGAT, INC.	ATTLEBORO	MA
AULT	AULT INC.	MINNEAPOLIS	MN
AVT	AVANTEK, INC.	SANTA CLARA	CA
AWC	ALPHA WIRE	ELIZABETH	NJ
B-T	BEK-TEK, INC.	READING	PA
BEK	BECKMAN INSTRUMENTS, INC.	FULLERTON	CA
BEL	BELDEN CORP.	GENEVA	IL
BER	BERG ELECTRONICS	NEW CUMBERLAND	PA
BGH	BEECH GROVE HARDWARE	BEECH GROVE	IN
BORDN	BORDEN INC.	COLUMBUS	OH
BOU	BOURNS, INC.	RIVERSIDE	CA
BREZ	BREEZE CORPORATIONS, INC.	UNION	NJ
BUCK	BUCKEYE STAMPING CO.	COLUMBUS	OH
BUD	BUD RADIO, INC.	WILLOUGHBY	OH
BURND	BURNDY CORP.	NORWALK	CT
BUS	BUSSMAN MFG.	ST. LOUIS	MO
BWC	BARON WIRE AND CABLE CORP.	NILES	IL
C-D	CORNELL DUBILIER ELECT. DIV.	NEWARK	NJ
C-E	CLINTON ELECTRONICS	ROCKFORD	IL
C-H	CUTLER-HAMMER, INC.	MILWAUKEE	WI
C-I	COMPONENTS, INC.	BIDDEFORD	ME
C-J	TRW/CINCH	ELK GROVE VILLAGE	IL
C-K	C & K COMPONENTS, INC.	WATERTOWN	MA
C-L	CENTRALAB DIV.	MILWAUKEE	WI
C-W	C-W INDUSTRIES	WARMINSTER	PA
CAI	CUSTOM ACCESSORIES, INC.	SKOKIE	IL
CAM	CAMBION	CAMBRIDGE	MA
CAR	CARLING ELECTRIC, INC.	WEST HARTFORD	CT



ABBRV	NAME.....	CITY.....	ST
CCM	CORCOM, INC.	CHICAGO	IL
CDC	COMPONENT DEVELOPMENT CORP.	CARSON	CA
CECO	CENTRAL COIL CO.	BRAZIL	IN
CGW	CORNING GLASS WORKS	CORNING	NY
CHE	CHERRY ELECTRICAL PRODUCTS	WAUKEGAN	IL
CHOM	CHOMERICS INC.	WOBURN	MA
CHRY	CHRYSLER CORP.	DETROIT	MI
CIMCO	CIMCO WIRE AND CABLE INC.	ALLENDALE	NJ
CKI	CTS KNIGHTS, INC.	SANDWICH	IL
CLA	CLAIREX CORP.	MT. VERNON	NY
CLAR	CLAROSTAT MFG. CO	DOVER	NH
CLFX	COLE-FLEX CORP.	BABYLON	NY
CPKG	CREATIVE PACKAGING DIV.	INDIANAPOLIS	IN
CTS	CHICAGO TELEPHONE SYSTEMS	CHICAGO	IL
CTS-E	CTS OF ELKHART	ELKHART	IN
CTSBR	CTS OF BERNE	BERNE	IN
CTSBV	CTS OF BROWNSVILLE	BROWNSVILLE	TX
DAL	DALE TECHNOLOGY CORP.	HARTSDALE	NY
DAV	HARRY DAVIES MOLDING CO.	CHICAGO	IL
DAYTN	DAYTON ELECTRIC CO.	CHICAGO	IL
DEL	DELEVAN DIV.	EAST AURORA	NY
DEN	DENNISON MFG. CO.	FRAMINGHAM	MA
DEW	DEWIRE FABRICATING CORP.	LOWELL	MA
DILEC	DILECTRON	MONROVIA	CA
DIO	DIODES, INC.	CHATSWORTH	CA
DRA	DRAKE MANUFACTURING CO.	HARWOOD HEIGHTS	IL
E-C	ELECTRONIC CRYSTALS	KANSAS CITY	MO
E-M	ELECTRA/MIDLAND CORP.	MINERAL WELLS	TX
ECMC	ELECTRI-CORD MFG. CO. INC.	WESTFIELD	PA
ELCO	ELCO INDUSTRIES	ROCKFORD	IL
ELFX	ELECTRO-FLEX HEAT INC.	BLOOMFIELD	CT
EMRON			S
EPITK	EPITEK ELECTRONICS	KANATA, ONT., CAN.	**
ETP	ERIE TECHNOLOGICAL PRODUCTS	ERIE	PA
EXAR	EXAR INTEGRATED SYSTEMS	SUNNYVALE	CA
F-K	THERMWELL PRODUCTS, INC.	FRAMINGHAM	MA
F-S	FEDERAL SCREW	CHICAGO	IL
FAN	FANCOURT & CO.	GREENSBORO	NC
FASTX	FASTEX DIV., ILL. TOOL WORKS	DES PLAINES	IL
FCD	FAIRCHILD	MOUNTAIN VIEW	CA
FRK	FRAKO	FRANKFORT, GER.	**
FRTE	FAIR RITE PRODUCTS CORP.	WALLKILL	NY
FRXC	FERROXCUBE DIVISION	SAUGERTIES	NY
G-E	GENERAL ELECTRIC	INDIANAPOLIS	IN
G-H	GRAYHILL, INC.	LA GRANGE	IL
G-I	GEN'L INSTRUMENT SEMICONDUCTOR	HICKSVILLE	NY
G-T	GRAND TRANSFORMERS	GRAND HAVEN	MI
GAL	GALILEO ELECTRO-OPTICS	CARMEL	IN
GATES	GATES ENERGY PROD.	DENVER	CO
GBN	GILBERT ENGINEERING CO. INC.	PHOENIX	AZ
GNATR	GENERAL ATRONICS CORP.	PHILADELPHIA	PA
GOU	GOULD, INC.	ST. PAUL	MN
GRIES	GRIES REPRODUCER	NEW ROCHELLE	NY
GRIP	GRIPMASTER CO.	MARLBORO	NJ
GUDL	GUDEBROD BROS. SILK CO.	CHICAGO	IL
H-P	HEWLETT-PACKARD	INDIANAPOLIS	IN

ABBRV	NAME.....	CITY.....	ST
HARTW	HARTWELL CORP.	PLACENTIA	CA
HEL	HELIPOT	ANAHEIM	CA
HEY	HEYMAN MFG. CO.	WAUKESHA	WI
HHS	HERMAN H. SMITH, INC.	BROOKLYN	NY
HIT	HITACHI AMERICA, LTD.	SAN FRANCISCO	CA
HOLGW	HOLLINGSWORTH SLDRLS TERM.	POTTSTOWN	PA
HOLUB	HOLUB DISTRIBUTING CO.	NEWPORT	KY
HSD	HARRIS CORP. SEMICDR. DIV.	MELBOURNE	FL
HUD	HUDSON TOOL & DIE CO.	NEWARK	NJ
HY/PL	HYDRO PLASTICS INC.	GEORGETOWN	KY
HYT	HYTRONICS	PINELLAS PARK	FL
ICI	ILLINOIS CAPACITOR INC.	MORTON GROVE	IL
IERC	INT'L ELEC. RESEARCH CORP.	BURBANK	CA
INDEC	INDUSTRIAL ELECTRONIC HDWR.	NEW YORK	NY
INT	INTERSIL, INC.	CUPERTINO	CA
INWEB	INTERNATIONAL WEBBING	WHITEHALL	PA
IRC	INTERNATIONAL RESISTANCE CO.	PHILADELPHIA	PA
IREC	INT'L RECTIFIER CORP.	LOS ANGELES	CA
ITT	INT'L TELEPHONE & TELEGRAPH	W. PALM BEACH	FL
JAN	JAN HARDWARE MFG. CO.	LONG ISLAND CITY	NY
JEF	JEFFERS	DUBOIS	PA
JEFWC	JEFFERSON WIRE AND CABLE	WORCHESTER	MA
JEW	JEWELL ELECTRICAL INSTRUMENTS	MANCHESTER	NH
JHSN	JOHANSON MFG. CORP.	BOONTON	NJ
JON	E.F. JOHNSON CO.	WASECA	MN
JUDD	JUDD WIRE DIV. ECC	TURNERS FALLS	MA
K-L	KERRIGAN LEWIS MFG.	CHICAGO	IL
K-S	K & S ENGINEERING CO.	CHICAGO	IL
KEENE	KEENE CORP.	NEWARK	DE
KEM	KEMTRON ELECTRON PRODUCTS	NEWBURYPORT	MA
KEY	KEYSTONE ELECTRONIC CORP.	NEW YORK	NY
KID	KIDCO, INC.	MEDFORD	NJ
KIN	KINGS ELECTRONICS	TUCKAHOE	NY
KSTR	KESTER SOLDER DIV.	CHICAGO	IL
KSW	KSW ELECTRONICS	INDIANAPOLIS	IN
KUL	KULKA ELECTRIC CORP.	MT. VERNON	NY
LAURN	LAUREN MFG CO.	NEW PHILADELPHIA	OH
LEYSE	LEYSE ALUMINUM CO.	KEWANEE	WI
LIT	LITTELFUSE, INC.	DES PLAINES	IL
LRC	LRC ELECTRONICS, INC.	HORNELL	NY
M-A	MICROWAVE ASSOCIATES	BURLINGTON	MA
M-D	MILLER DIAL & NAMEPLATE CO.	EL MONTE	CA
M-E	MEPCO ELECTRA, INC.	MORRISTOWN	NJ
M-O	ILLUMINATED PRODUCTS INC.	SANTA ANA	CA
M-P	MICRO PLASTICS INC.	CHATSWORTH	CA
MAL	MALLORY CONTROLS CO.	FRANKFORT	IN
MAND	MANDEX	CHICAGO	IL
MARQ	J. & J. MARQUARDT	TUTTILINGEN, GER.	**
MDC	MAIDA DEVELOPMENT CO.	HAMPTON	VA
MILN	MILLEN MFG. CO.	NEW YORK	NY
MILSP	MILITARY SPECIFICATION	WASHINGTON	DC
MINOR	MINOR RUBBER CO.	BLOOMFIELD	NJ
MITEK	MITEK	LEXINGTON	MA
MLRQW	J.W. MILLER	COMPTON	CA
MMM	3M COMPANY	ST. PAUL	MN
MNO	MONSANTO COMM. PROD. DIV.	PALO ALTO	CA

ABBRV	NAME.....	CITY.....	ST
MOL	MGLEX PRODUCTS	LISLE	IL
MORAD	MORGAN ADHESIVES	STOW	OH
MOT	MOTOROLA SEMI. PROD. DIV.	INDIANAPOLIS	IN
MRO	MICRO SWITCH DIV.	FREEPORT	IL
MSN	MICROSONICS DIV.	WEYMOUTH	MA
MSP	MICRO SEMICONDUCTOR CORP.	SANTA ANA	CA
MWS	MAGNET WIRE SUPPLY CO.	CHATSWORTH	CA
MYERS	MYERS SPRING CO.	LOGANSPOET	IN
N-T	NATIONAL TEL-TRONICS	LAREDO	TX
NAT	NATIONAL SEMICONDUCTOR CORP.	SANTA CLARA	CA
NEC	NIPPON ELECTRIC CO.	TOKYO, JAPAN	**
NEL	NATIONAL ENGINEERING LABS	INDIANAPOLIS	IN
NEW	NEWARK ELECTRONICS	INDIANAPOLIS	IN
NPC	NUCLEONIC PRODUCTS CO.	CANOGA PARK	CA
NYLO	NYLOMATIC	MORRISVILLE	PA
O-G	OPTI-GAGE INC.	DAYTON	OH
O-S	OMNI SPECTRA INC.	FARMINGTON	MI
OAK	OAK INDUSTRIES INC.	CRYSTAL LAKE	IL
OHM	OHMITE MFG. CO.	SKOKIE	IL
OMEGA	OMEGA WIRE & CABLE	HARLEYSVILLE	PA
OPTRN	OPTRON INC.	CARROLLTON	TX
P-B	POTTER AND BRUMFIELD	PRINCETON	IN
P-C	POWER COMPONENTS	WOODLAND HILLS	CA
P-K	PARKER KALON CORP.	CLIFTON	NJ
P-T	PENN TUBE PLASTICS CO.	CLIFTON HEIGHTS	PA
P-U	PROJECTS UNLIMITED INC.	DAYTON	OH
POLPH	POLYPHASE INSTR. CO.	BRIDGEPORT	PA
PAM	PAMOTOR DIV.	BURLINGAME	CA
PAM	PAMOTOR DIV.	BURLINGAME	CA
PAND	PANDUIT CORP.	TINLEY PARK	IL
PARA	PARAMETRIC INDUSTRIES	NORTHFIELD	IL
PCC	PANEL COMPONENTS CORP.	BERKELEY	CA
PEC	PACIFIC ELECTRICORD CO.	GARDENA	CA
PHC	PHILADELPHIA HANDLE CO.	CAMDEN	NJ
PIC	PIHER INTERNATIONAL CORP.	ARLINGTON HEIGHTS	IL
PLSSY	PLESSEY ENG.	SCHILLER PARK	IL
PMCL	PERMACEL DIV.	NEW BRUNSWICK	NJ
PMI	PRECISION MONOLITHICS INC.	SANTA CLARA	CA
POM	POMONA ELECTRONICS CO., INC.	POMONA	CA
PRMD	PYRAMID INDUSTRIES, INC.	PHOENIX	AZ
PRSN	PRECISION TUBE CO., INC	NORTH WALES	PA
PTN	PENN TRAN CORP.	BELLEFONT	PA
PYRO	PYROFILM CORP.	WHIPPANY	NY
PYTT	PYTTRONICS INDUSTRIES, INC.	MONTGOMERYVILLE	PA
Q-C	QUALITY COMPONENTS	ST. MARYS	PA
R-N	ROBINSON-NUGENT	NEW ALBANY	IN
RAY	RAYTHEON	INDIANAPOLIS	IN
RCA	RCA	CAMDEN	NJ
REL	RELIANCE MICA CO.	BROOKLYN	NY
RGR	ROGERS CORP.	CHANDLER	AZ
RICH	RICHCO PLASTIC CO.	CHICAGO	IL
RICHM	RICHARDS METAL PRODUCTS	WOLCOTT	CT
RMC	RADIO MATERIALS CORP.	CHICAGO	IL
RMF	RMF PRODUCTS INC.	BATAVIA	IL
ROGAN	ROGAN CORP.	NORTHBROOK	IL
S-C	SPECIALTY CONNECTOR	INDIANAPOLIS	IN

ABBRV	NAME.....	CITY.....	ST
S-G	STANDARD GRIGSBY	AURORA	IL
S-I	SWITCHCRAFT, INC.	CHICAGO	IL
S-S	SERVICE SUPPLY	INDIANAPOLIS	IN
S-T	SARKES TARZIAN	BLOOMINGTON	IN
SCBE	SCANBE DIVISION	EL MONTE	CA
SCC	STACKPOLE CARBON CO.	ST. MARYS	PA
SCX	SILICONIX INC.	SANTA CLARA	CA
SEAST	SEASTROM MFG. CO.	GLENDALE	CA
SECR	SECOR INC.	WESTWOOD	NJ
SEL	SEAELECTRO CORP.	MAMARONECK	NY
SEM	SEMTECH	NEWBURY PARK	CA
SEMTX	SEMTEX	DAYTON	OH
SGM	SIGMA INSTRUMENTS	BRAINTREE	MA
SHAM	SHAMROCK PLASTICS & RUBBER CO.	INDIANAPOLIS	IN
SIEM	SIEMENS	ISELIN	NJ
SIG	SIGNETICS CORPORATION	SUNNYVALE	CA
SLT	SOLITRON/MICROWAVE DIV.	PORT SALERNO	FL
SMTC	SAMTEC INC.	NEW ALBANY	IN
SOUTH	SOUTHCO FASTENERS	LESTER	PA
SPE	SPECTROL	DAYTON	OH
SPEC	SPECTRUM CONTROL, INC.	FAIRVIEW	PA
SPR	SPRAGUE ELECTRIC CO.	INDIANAPOLIS	IN
SPST	SPECTRA-STRIP	GARDEN GROVE	CA
SSS	SOLID STATE SCIENTIFIC	MONTGOMERYVILLE	PA
STDPS	STANDARD PRESSED STEEL	JENKINTOWN	PA
STR	STETTNER TRUSH CO.	CAZENOVIA	NY
STSA	STEEL SALES	INDIANAPOLIS	IN
SYL	GTE SYLVANIA	WALTHAM	MA
SYS	SYSCON INTERNATIONAL, INC.	SOUTH BEND	IN
T-I	TEXAS INSTRUMENTS	DALLAS	TX
TCPL	TACONIC PLASTIC	PETERSBURG	NY
TEK	TEKTRONIX	INDIANAPOLIS	IN
TEKA	TEKA PRODUCTS INC.	COLLEGE POINT	NY
TELE	TELETYPE CORP.	ELK GROVE VILLAGE	IL
THR	THERMALLOY CO.	DALLAS	TX
TIMES	TIMES WIRE AND CABLE	CINCINNAI	OH
TIN	TINNERMAN PRODUCTS, INC.	CLEVELAND	OH
TKN	TECHNICAL WIRE	CRAWFORD	NJ
TLNC	TELCNIC ALTAIR	LAGUNA BEACH	CA
TORCO	TOR CORP.	VAN NUYS	CA
TR-UT	TRIAD-UTRAD DIV.	HUNTINGTON	IN
TRU	WALDES TRUARC	LONG ISLAND CITY	NY
TRW	TRW CAPACITOR DIV.	OGALLALA	NB
TVL	TEL-VISION LABS	WAUCONDA	IL
U-C	UNIVERSAL COMPONENTS	LOS ANGELES	CA
UNCAR	UNION CARBIDE COMPONENTS	GREENVILLE	SC
UNIC	UNICORP	ORANGE	NJ
UNIT	UNITRODE CORP.	WATERTOWN	MA
USECO	USECO DIV.	VAN NUYS	CA
UTK	UNITRACK DIV.	UPPER DARBY	PA
VAC	VACTEC INC.	MARYLAND HEIGHTS	MO
VACO	VACO PRODUCTS CO.	NORTHBROOK	IL
VAR	VARADYNE CAPACITOR DIV.	SANTA MONICA	CA
VARIL	VARI-L CO.	DENVER	CO
VELCR	VELCRO USA INC	NEW YORK	NY
VLIER	VLIER ENGINEERING CORP.	BURBANK	CA

ABBRV	NAME.....	CITY.....	ST
VONGT	VONNEGUT HARDWARE	INDIANAPOLIS	IN
VRN	VERNITRON CORP.	GREAT NECK	NY
VRN	VERNITRON CORP.	GREAT NECK	NY
W-E	WELLS ELECTRONICS	SOUTH BEND	IN
W-I	WAVETEK INDIANA, INC.	BEECH GROVE	IN
WAG	WAGNER ELECTRIC CORP.	ST. LOUIS	MO
WECK	WECKESSER CO., INC.	CHICAGO	IL
WAFLD	WAKEFIELD ENGINEERING	WAKEFIELD	MA
WNSL	WEINSCHHEL ENGINEERING	GAITHERSBURG	MD
WSD	WAVETEK	SAN DIEGO	CA
WBR	WAVETEK	SANTA ROSA	CA
ZEN	ZENITH RADIO CORP.	CHICAGO	IL
ZERQ	ZERO MANUFACTURING CO.	BURBANK	CA
ZIE	ZIERICK MFG. CORP.	MOUNT KISCO	NY
ZPT	ZIPPERTUBING, CO.	LOS ANGELES	CA

REFERENCE DESIGNATORS	PART DESCRIPTION	ORIG-MFGR-PART-NO	MFGR	WAVETEK NO.	QTY
1	CHASSIS 2002A	1111-00-0083	W-I	1111-00-0083	1
2	CABINET 2002A	1111-00-0084	W-I	1111-00-0084	1
3	FRONT PANEL 2002A	1118-00-0018	W-I	1118-00-0018	1
4	POWER SUPPLY, DPS2A	DPS2A	W-I	1115-00-0011	1
5	SWEEP RATE, M101B	M101B	W-I	1114-00-0267	1
6	SWEEP DRIVE, M102A	M102A	W-I	1114-00-0268	1
7	SWEEP DRIVE, M103A	M103A	W-I	1114-00-0269	1
8	LEVELER, M104A	M104A	W-I	1114-00-0270	1
9	MKR ADDER, M105	M105	W-I	1114-00-0137	1
10	SWP OSC, M109	M109	W-I	1114-00-0138	1
11	SWP OSC, M110	M110	W-I	1114-00-0139	1
12	OUTPUT AMPLIFIER MA111	MA111	W-I	1118-00-0014	1
13	MODULATOR, M121	M121	W-I	1114-00-0205	1
14	BAND SELECT, M131	M131	W-I	1114-00-0252	1
15	INTERFACE, M132	M132	W-I	1114-00-0251	1
16	EXT MKR, M6C	M6C	W-I	1114-00-0124	1
<b>WAVETEK PARTS LIST</b>		TITLE SWP GEN. 2002A	ASSEMBLY NO. 1010-00-0141  PAGE: 1		REV A

REFERENCE DESIGNATORS	PART DESCRIPTION	ORIG-MFGR-PART-NO	MFGR	WAVETEK NO.	QTY
P1	PRDG PLUG, A529-004	A529-004	W-I	1118-00-0012	1
P5	SMC TERM, 50 A500-267	A500-267	W-I	1118-00-0007	1
W1 W2	CABLE ASSY, 2-1/2 IN	WX2002-W1	W-I	1217-00-0024	2
W3	CABLE ASSY, 4-1/2IN	WX2002-W3	W-I	1217-90-0016	1
W4	CABLE ASSY, 2-3/8 IN	WX2002A-W4-WNSL	W-I	1217-90-0038	1
W5	CABLE ASSY, 10-1/4 IN	WX3000-200-W21	W-I	1217-00-0102	1
W6	CABLE ASSY, 12 IN	WX2002-W6	W-I	1217-80-0022	1
HH1	HARNESS 2002A-A, B, C	1219-00-0150	W-I	1219-00-0150	1
<b>WAVETEK PARTS LIST</b>		TITLE SWP GEN. 2002A	ASSEMBLY NO. 1010-00-0141  PAGE: 2		REV A

REFERENCE DESIGNATORS	PART DESCRIPTION	ORIG-MFGR-PART-NO	MFGR	WAVETEK NO.	QTY
C01	CAP, TANT, .47MF, 50V CE113-447	935	TRW	1510-21-9470	1
IC1	IC, IC000-026	MC7818CD	MDT	7000-78-1800	1
R24	POT, 1K RP124-210	WA26032S-102MA	A-B	4610-10-7102	1
R25	RES, C, 1/4W, 5%, 2K RC103-220	CF1/4-2K	ASE	4700-15-2001	1
<b>WAVETEK PARTS LIST</b>		TITLE CHASSIS 2002A	ASSEMBLY NO. 1111-00-0083		REV
			PAGE: 1		

REFERENCE DESIGNATORS	PART DESCRIPTION	ORIG-MFGR-PART-NO	MFGR	WAVETEK NO.	QTY
J6	CONN, BNC, JB000-023	KC79-167	KIN	2110-01-1009	1
S5 S6	SWITCH, TOG, BLK ANOD	7101PN	C-K	5106-00-0009	2
NONE	HARNES, 2002A-D	1219-00-0152	W-I	1219-00-0152	1
<b>WAVETEK PARTS LIST</b>		TITLE REAR PANEL 2002A	ASSEMBLY NO. 1118-00-0040		REV
			PAGE 1		

REFERENCE DESIGNATORS	PART DESCRIPTION	ORIG-MFGR-PART-NO	MFGR	WAVETEK NO.	QTY
P3	HSG, MINI-LATCH, 5-PIN	65039-032	BER	2113-10-0001	1
NONE	TERM, MALE, MC000-116	48116	BER	2113-22-0001	4
<b>WAVETEK PARTS LIST</b>		TITLE HARNES 2002A-D	ASSEMBLY NO. 1219-00-0152		REV
			PAGE: 1		

REFERENCE DESIGNATORS	PART DESCRIPTION	ORIG-MFGR-PART-NO	MFGR	WAVETEK NO.	QTY
A1	ATTEN 0-70/10DB	9833	WNSL	3010-52-0003	1
C02	CAP, CER, 20PF, 1KV CD101-020	60C0G200J	MDC	1510-10-0200	1
C03	CAP, CER, 120PF, 1KV CD102-112	60U121M	MDC	1510-10-1121	1
C05	CAP, CER, 360PF, 1KV CD102-136	60U361M	MDC	1510-10-1361	1
CR13	LED DL000-003	5082-4955	H-P	4810-02-0003	1
CR14	LED DL000-001	NSL5046	NAT	4810-02-0001	1
J05 J09 J10 J11	CONN, BNC, JB000-023	KC79-167	KIN	2110-01-1009	4
M1	METER, OUTPUT LEVEL MI000-006	MI000-006	W-I	2410-06-0002	1
R07 R08	RES, C, 1/4W, 5%, 10K RC103-310	CF1/4-10K	ASE	4700-15-1002	2
R18	RES, C, 1/2W, 5%, 680 RC105-168	CF1/2-680	ASE	4700-25-6800	1
R21 R30	RES, C, 1/4W, 5%, 47K RC103-347	CF1/4-47K	ASE	4700-15-4702	2
R24	POT., DUAL, 10K-OHM PER B/P	CM42826	CLAR	4610-40-1103	1
<b>WAVETEK PARTS LIST</b>		TITLE FRONT PANEL 2002A	ASSEMBLY NO. 1118-00-0018  PAGE: 1		REV B

REFERENCE DESIGNATORS	PART DESCRIPTION	ORIG-MFGR-PART-NO	MFGR	WAVETEK NO.	QTY
R31	RES, C, 1/4W, 5%, 1M RC103-510	CF1/4-1M	ASE	4700-15-1004	1
S06 S13	SWITCH, TOG, BLK ANDD, ST001-006	7101PN	C-K	5106-00-0009	2
S07	SWITCH, TOGGLE ST002-006	7107PN-BLK	C-K	5106-00-0011	1
S09	SWITCH, PB, SZ001-004	2KCB070000-304BL	C-L	5110-00-0006	1
S10	SWITCH ASSY, ROTARY SR000-031	SR000-031	W-I	5104-00-0018	1
S12	SWITCH, TOGGLE ST000-006	7103PN-BLK	C-K	5106-00-0004	1
43	START ASSY A529-010	A529-010	W-I	1219-00-0061	1
44	STOP ASSY, A529-011	A529-011	W-I	1219-00-0060	1
45	PC ASSY, B530-009	A530-009	W-I	1218-00-1020	1
46	SWP TIME ASSY, 2002A	1118-00-0038	W-I	1118-00-0038	1
47	MKR SW ASSY A523-008	A523-008	W-I	1212-00-0003	1
48	MODE SW ASSY A529-008	A529-008	W-I	1212-00-0002	1
49	BAND SW, 2002A	1212-00-0008	W-I	1212-00-0008	1
42	PWR SW ASSY, 16-1/2	1212-00-0006	W-I	1212-00-0006	1
<b>WAVETEK PARTS LIST</b>		TITLE FRONT PANEL 2002A	ASSEMBLY NO. 1118-00-0018  PAGE: 2.		REV B



REFERENCE DESIGNATORS	PART DESCRIPTION	ORIG-MFGR-PART-NO	MFGR	WAVETEK NO.	QTY
C4	CAP,CER,15PF,1KV	10TCC-Q15	SPR	1510-10-0150	1
CR2 CR3	DIODE	IN4148	FCD	4807-01-0914	2
CR4 CR5 CR6 CR7 CR8 CR9 CR10 CR11	DIODE	IN4004	P-C	4806-01-4004	8
CR12	DIODE	IN34A	HIT	4807-01-0034	1
P1	PLUG,36-PIN	03-06-2362	MOL	2113-04-0005	1
NONE	TERMINAL,MALE	1854	MOL	2113-05-0002	6
P201	PLUG	19-09-2042	MOL	2113-26-0001	1
NONE	TERMINAL,MALE	02-09-2118	MOL	2113-09-0004	4
R4	RES,MF,1/8W,1%,10K	MF55K10K	ASE	4701-03-1002	1
R5	RES,MF,1/8W,1%,40.2K	MF55K-40.2K	ASE	4701-03-4022	1
R6	RES,C,1/4W,5%,47K	CF1/4-47K	ASE	4700-15-4702	1
R7 R8	RES,C,1/4W,5%,10K	CF1/4-10K	ASE	4700-15-1002	2
R9	RES,C,1/4W,5%,43K	CF-1/4-43K	ASE	4700-15-4302	1
R10	RES,C,1/4W,5%,27K	CF1/4-27K	ASE	4700-15-2702	1
R11	POT,50K	360S503B	CTS	4610-00-1503	1
R12	RES,MF,1/8W,1%,47.5K	MF55K-47.5K	ASE	4701-03-4752	1
R13	RES,C,1/4W,5%,470K	CF1/4-470K	ASE	4700-15-4703	1
<b>WAVETEK PARTS LIST</b>	TITLE	ASSEMBLY NO.		REV	
	F.P. SUB-ASSY PARTS	-----			
PAGE 1					

REFERENCE DESIGNATORS	PART DESCRIPTION	ORIG-MFGR-PART-NO	MFGR	WAVETEK NO.	QTY
R14	RES,P/O SWITCH ASSY	SWITCH-P	W-I	4799-99-9998	1
R15	RES,C,1/4W,5%,4.7M	CB4755	A-3	4700-15-4704	1
R16	RES,C,1/4W,5%,47M	CB4765	A-3	4700-15-4705	1
R17	RES,C,1/4W,5%,470	CF1/4-470	ASE	4700-15-4700	1
R19 R20	POT,CONT,10K	534	SPE	4610-20-1103	2
R32	RES,C,1/4W,5%,4.7K	CF1/4-4.7K	ASE	4700-15-4701	1
R33	RES,C,1/4W,5%,33K	CF1/4-33K	ASE	4700-15-3302	1
S1	SWITCH,LEVER	A42125	S-G	5101-00-0007	1
S2	SWITCH ASSY,ROTARY	SR000-017	W-I	5104-00-0005	1
S3	SWITCH,LEVER	184A1	OAK	5101-00-0001	1
S4	SWITCH,SLIDE	GF124/G20-18	C-W	5105-00-0007	1
S11	SWITCH ASSY,ROTARY	SR000-016	W-I	5104-00-0004	1
S201	SWITCH,TOGGLE DPDT	9201P3HZQ	C-K	5106-00-0016	1
<b>WAVETEK PARTS LIST</b>	TITLE	ASSEMBLY NO.		REV	
	F.P. SUB-ASSY PARTS	-----			
PAGE 2					

REFERENCE DESIGNATORS	PART DESCRIPTION	ORIG-MFGR-PART-NO	MFGR	WAVETEK NO.	QTY
J1	RECEPTACLE, 36-PIN	03-06-1361	MOL	2113-03-0004	1
NONE	TERMINAL, FEMALE MC000-018	02-06-1131	MOL	2113-05-0001	23
J12	HSG. MINI-LATCH, 10PIN MC000-130	65039-027	BER	2113-10-0010	1
NONE	PLUG, POLARIZING MC000-117	65307-001	BER	2113-23-0001	3
NONE	TERM, MINI-PV MC000-092	47439	BER	2113-20-0001	19
J2	JACK, FEMALE, 9-CKT MC000-067	09-50-3091	MOL	2113-06-0001	1
NONE	CONTACT MC000-068	08-50-0107	MOL	2113-07-0001	8
J3	HSG. MINI-LATCH, 5-PIN MC000-111	65039-032	BER	2113-10-0001	1
J4 P4	HSG. MINI-LATCH, 6-PIN MC000-112	65039-031	BER	2113-10-0002	2
NONE	TERM. MALE, MC000-116	48116	BER	2113-22-0001	6
NONE	TERM, FEMALE MC000-042	02-06-1103	MOL	2113-05-0004	1
<b>WAVETEK PARTS LIST</b>		TITLE HARNES 2002A-A, B, C	ASSEMBLY NO. 1219-00-0150  PAGE: 1		REV

REFERENCE DESIGNATORS	PART DESCRIPTION	ORIG-MFGR-PART-NO	MFGR	WAVETEK NO.	QTY
C001	DIODE D9109-140	1N414B	FCD	4807-01-0914	1
J02 J03	POST, BINDING, BLK MC000-038	2439	PGM	2112-01-0001	2
K01	RELAY, SPST MR000-001	JRM1006	P-B	4510-00-0001	1
Q01 Q02	TRANS QA038-541	2N3854A	Q-E	4901-03-8541	2
R01	RES, C, 1/4W, 5%, 470 RC103-147	CF1/4-470	ASE	4700-15-4700	1
R02	RES, C, 1/4W, 5%, 10K RC103-310	CF1/4-10K	ASE	4700-15-1002	1
R03 R04	RES, C, 1/4W, 5%, 22K RC103-322	CF1/422K	ASE	4700-15-2202	2
<b>WAVETEK PARTS LIST</b>		TITLE PEN LIFT ASSY	ASSEMBLY NO. 1118-00-0029  PAGE: 1		REV

REFERENCE DESIGNATORS	PART DESCRIPTION	ORIG-MFGR-PART-NO	MFGR	WAVETEK NO.	QTY
F101	FUSE, SLD BLD, 1 AMP, 250V	MDL-1	BUS	2410-05-0005	1
IC101	POS, VOLTAGE REG.	LM317T	NAT	7000-03-1700	1
J101	CONN, 6-PIN, KONEKTON MC000-076	09-50-3061	MDL	2113-06-0002	1
J201	RECEPTACLE	19-09-1042	MDL	2113-26-0002	1
18	CONTACT, MC000-131	08-50-0106	MDL	2113-07-0002	5
Q101 Q102	PROT PWR DARLINGTON	LM395T	NAT	4902-00-3950	2
S101	SWITCH, SLIDE, DPDT	EPSI-SLI	S-I	5105-00-0011	1
T101	XFMR, PWR	8720	A-M	5610-00-0027	1
23	PC ASSEMBLY, DPS2A	1218-00-0250	W-I	1218-00-0250	1
24	LINE CORD ASSEMBLY	1219-00-0144	W-I	1219-00-0144	1

<b>WAVETEK PARTS LIST</b>	TITLE POWER SUPPLY, DPS2A	ASSEMBLY NO. 1115-00-0011	REV C
		PAGE: 1	

REFERENCE DESIGNATORS	PART DESCRIPTION	ORIG-MFGR-PART-NO	MFGR	WAVETEK NO.	QTY
C02 C06	CAP, CER, .005MF, 100V	TG-D50	SPR	1510-10-2502	2
C02 C06	CAP, CER, .005MF, 100V	TG-D50	SPR	1510-10-2502	2
C03 C05 C07	CAP, ELECT, 1MF, 25V CE120-001	162D105X9025BC2	SPR	1510-21-7010	3
C04 C09	CAP, ELECT, 100MF, 25V CE105-110	TE1211	SPR	1510-20-4101	2
C10	CAP, 10000MF, 16V CE122-310	D76381	SPR	1510-21-4103	1
C11	CAP, TANT, 10MF, 25V CE120-010	162D106X0025DD2	SPR	1510-21-7100	1
CR01	DIODE BRIDGE	MDA101	MOT	4806-02-0003	1
CR02 CR04	DIODE DG109-140	1N4148	FCD	4807-01-0914	2
CR03 CR05 CROB	DIODE DR000-001	1N4004	P-C	4806-01-4004	3
CR06 CR07	DIODE DR000-009	1N5624	G-E	4806-01-5624	2
F01	FUSE, S. B., 2AMP MF000-002	313-002	LIT	2410-05-0001	1
IC01	VOLTAGE REFERENCE	REF-02CJ	PMI	7000-00-0200	1
IC02	DUAL OP AMP	TL082CP	T-I	7000-00-8200	1
J01 J02 J03	CONN., RECEPT., 3-PIN	6-86105-3	AMP	2112-25-0001	3

<b>WAVETEK PARTS LIST</b>	TITLE PC ASSEMBLY, DPS2A	ASSEMBLY NO. 1218-00-0250	REV C
		PAGE: 1.	

REFERENCE DESIGNATORS	PART DESCRIPTION	ORIG-MFGR-PART-NO	MFGR	WAVETEK NO.	QTY
P01	PLUG, 6-PIN KONEKTON MC000-075	09-65-1061	MOL	2112-05-0002	1
P02	CONN, MALE, 9-PIN MC000-071	09-65-1091	MOL	2112-05-0001	1
Q01	JFET, N-CHANNEL	E232	SCX	4902-00-2320	1
Q02	TRANS GA039-060	2N3906	T-I	4901-03-9060	1
R01 R12 R14	RES. C, 1/4W, 5%, 4.7K RC103-247	CF1/4-4.7K	ASE	4700-15-4701	3
R02	RES. C, 1/4W, 5%, 1K RC103-210	CF1/4-1K	ASE	4700-15-1001	1
R03	RES. C, 1/4W, 5%, 39K RC103-339	CF1/4-39K	ASE	4700-15-3902	1
R04	RES. MF, 1/8W, 1%, 4.87K RF212-487	MF55K-4.87K	ASE	4701-03-4871	1
R05	RES. VAR. CERMET, 500	89PR500	BEK	4610-00-2501	1
R06	RES. C, 1/4W, 5%, 3.9K RC103-239	CF1/43.9K	ASE	4700-15-3901	1
R08	RES. MF, 1/8W, 1%, 13.0K RF213-130	MF55K-13.0K	ASE	4701-03-1302	1
R09 R11	RES. MF, 1/8W, 1%, 10K RF213-100	MF55K10K	ASE	4701-03-1002	2
<b>WAVETEK PARTS LIST</b>		TITLE PC ASSEMBLY, DPS2A	ASSEMBLY NO. 1218-00-0250  PAGE: 2		REV C

REFERENCE DESIGNATORS	PART DESCRIPTION	ORIG-MFGR-PART-NO	MFGR	WAVETEK NO.	QTY
R10	RES., VAR. CERMET 200-OHM	89PR200	BEK	4610-00-2201	1
R13	RES. C, 1/4W, 5%, 10K RC103-310	CF1/4-10K	ASE	4700-15-1002	1
R15	RES. C, 1/4W, 5%, 1.2K RC103-212	CF1/4-1.2K	ASE	4700-15-1201	1
R16	RES., M.F., 1/8W, 1%, 150-OHM	MF55K-150	ASE	4701-03-1500	1
R18	RES., M.F., 1/8W, 1%, 768-OHM	MF55K-768	ASE	4701-03-7680	1
<b>WAVETEK PARTS LIST</b>		TITLE PC ASSEMBLY, DPS2A	ASSEMBLY NO. 1218-00-0250  PAGE: 3		REV C

REFERENCE DESIGNATORS	PART DESCRIPTION	ORIG-MFGR-PART-NO	MFGR	WAVETEK NO.	QTY
6	TERM, FEMALE MC000-136	02-09-1118	MOL	2113-09-0003	4
P202	CORD SET, 18/3SVT, 6FT GRY, MLD. CAP, UL-APPRV	17237SVT	BEL	6011-80-0001	1
<b>WAVETEK PARTS LIST</b>		TITLE LINE CORD ASSEMBLY	ASSEMBLY NO. 1219-00-0144  PAGE: 1		REV B

REFERENCE DESIGNATORS	PART DESCRIPTION	ORIG-MFGR-PART-NO	MFGR	WAVETEK NO.	QTY
C01 C02 C03 C04 C05 C06 C07 C08 C18 C19 C20 C21 C22 C23	CAP, F. T., .6.8PF CF102-R68	FA5C-6892	A-B	1510-30-1689	14
C09	CAP, MYLAR, .15MF, 100V CP103-415	WMF1P15	C-D	1510-60-2154	1
C10 C26	CAP, CER, .005MF, 1KV CD102-250	5GA-D50	SPR	1510-10-1502	2
C11 C12	CAP, CER, .001MFD, 1KV CD102-210	5GAD10	SPR	1510-10-1102	2
C13	CAP, CER, 470PF, 1KV CD102-147	60U471M	MDC	1510-10-1471	1
C14 C17	CAP, ELECT, 1MF, 25V CE120-001	162D105X9025BC2	SPR	1510-21-7010	2
C15	CAP, CER, .01MF, 100V CD103-310	6BU103M	MDC	1510-10-2103	1
C16	CAP, CER, 10PF, 1KV CD101-010	10TCC-G10	SPR	1510-10-0100	1
C24 C25	CAP, F. T., .470PF CF101-147	FA5C-4712	A-B	1510-30-0471	2
CR01 CR03	DIODE DR000-001	1N4004	P-C	4806-01-4004	2
CR02 CR04 CR05 CR06 CR07 CR08 CR09 CR10 CR11 CR12 CR13 CR14 CR15 CR17 CR18 CR19	DIODE DG109-140	1N4148	FCD	4807-01-0914	18
<b>WAVETEK PARTS LIST</b>		TITLE SWEEP RATE, M101B	ASSEMBLY NO. 1114-00-0267  PAGE: 1		REV B

REFERENCE DESIGNATORS	PART DESCRIPTION	ORIG-MFGR-PART-NO	MFGR	WAVETEK NO.	QTY
CR20 CR21					
IC1	OP AMPL TO-5 ILO03-004	LF355H	NAT	7000-03-5501	1
IC2	IC, IC000-002	N5741CV	SIG	7000-57-4100	1
IC3 IC4 IC5	IC, IC000-005	RC455BDN	RAY	7000-14-5800	3
IC6	DUAL OP AMP	TL082CP	T-I	7000-00-8200	1
Q1	TRANS QB000-009	MPS3702	MOT	4902-03-7020	1
Q2	TRANS GA038-541	2N3854A	G-E	4901-03-8541	1
Q3	TRANS GA054-580	2N5458	MOT	4901-05-4580	1
Q4	TRANS GA054-610	2N5461	MOT	4901-05-4610	1
R01	RES, C, 1/4 W, 5%, 43K RC103-343	CF-1/4-43K	ASE	4700-15-4302	1
R02 R60	POT, 20K, RP129-320	360S203B	CTS	4610-00-1203	2
R03	RES, MF, 1/8W, 1%, 88.7K RF213-887	MF55K-88.7K	ASE	4701-03-8872	1
R04 R14 R40	RES, C, 1/4W, 5%, 150K RC103-415	CF1/4-150K	ASE	4700-15-1503	3
R05	RES, C, 1/4W, 5%, 27K RC103-327	CF1/4-27K	ASE	4700-15-2702	1
<b>WAVETEK PARTS LIST</b>		TITLE SWEEP RATE, M101B	ASSEMBLY NO. 1114-00-0267  PAGE: 2		REV B

REFERENCE DESIGNATORS	PART DESCRIPTION	ORIG-MFGR-PART-NO	MFGR	WAVETEK NO.	QTY
R06	RES, C, 1/4W, 5%, 1K RC103-210	CF1/4-1K	ASE	4700-15-1001	1
R07 R29	RES, C, 1/4W, 5%, 82K RC103-382	CF1/4-82K	ASE	4700-15-8202	2
R08/R11 R23/R24 R36/R41	RES, SET, 2-10K, 1/8W QTY: 2: 4701-03-1002	RX000-003	W-I	4789-00-0004	3
R09 R32 R53 R54	RES, C, 1/4W, 5%, 120K RC103-412	CF1/4-120K	ASE	4700-15-1203	4
R10 R43	RES, C, 1/4W, 5%, 12K RC103-312	CF1/4-12K	ASE	4700-15-1202	2
R12 R56	RES, C, 1/4W, 5%, 1.2M RC103-512	CF1/4-1.2M	ASE	4700-15-1204	2
R13 R25 R28 R38 R57 R58	RES, C, 1/4W, 5%, 47K RC103-347	CF1/4-47K	ASE	4700-15-4702	6
R15	RES, C, 1/4W, 5%, 1.5M RC103-515	CF1/4-1.5M	ASE	4700-15-1504	1
R16 R18 R61	RES, MF, 1/8W, 1%, 48.7K RF213-487	MF55K-48.7K	ASE	4701-03-4872	3
R17	POT, 2K, RP129-220	360S202B	CTS	4610-00-1202	1
R19 R63	RES, C, 1/4W, 5%, 22K RC103-322	CF1/422K	ASE	4700-15-2202	2
R20	RES, MF, 1/8W, 1%, 44.2K RF213-442	MF55K-44.2K	ASE	4701-03-4422	1
<b>WAVETEK PARTS LIST</b>	TITLE SWEEP RATE, M101B	ASSEMBLY NO. 1114-00-0267			REV B
		PAGE: 3			

REFERENCE DESIGNATORS	PART DESCRIPTION	ORIG-MFGR-PART-NO	MFGR	WAVETEK NO.	QTY
R21	RES, MF, 1/8W, 1%, 56.2K RF213-562	MF55K-56.2K	ASE	4701-03-5622	1
R22	RES, C, 1/4W, 5%, 4.7M RC103-547	CB4755	A-B	4700-15-4704	1
R26	RES, C, 1/4W, 5%, 56K RC103-356	CF1/4-56K	ASE	4700-15-5602	1
R30	RES, C, 1/4W, 5%, 33K RC103-333	CF1/4-33K	ASE	4700-15-3302	1
R31	RES, C, 1/4W, 5%, 22 RC103-022	CF1/4-22	ASE	4700-15-2209	1
R33	RES, C, 1/4W, 5%, 68K RC103-368	CF1/4-68K	ASE	4700-15-6802	1
R34 R42	RES, C, 1/4W, 5%, 2.7K RC103-227	CF1/4-2.7K	ASE	4700-15-2701	2
R35 R50	RES, C, 1/4W, 5%, 1M RC103-510	CF1/4-1M	ASE	4700-15-1004	2
R37	RES, C, 1/4W, 5%, 8.2K RC103-282	CF1/4-8.2K	ASE	4700-15-8201	1
R39	RES, C, 1/4W, 5%, 680K RC103-468	CF1/4-680K	ASE	4700-15-6803	1
R44	RES, C, 1/4W, 5%, 10K RC103-310	CF1/4-10K	ASE	4700-15-1002	1
<b>WAVETEK PARTS LIST</b>	TITLE SWEEP RATE, M101B	ASSEMBLY NO. 1114-00-0267			REV B
		PAGE: 4			

REFERENCE DESIGNATORS	PART DESCRIPTION	DRIG-MFGR-PART-NO	MFGR	WAVETEK NO.	QTY
R45	RES, C, 1/4W, 5%, 330K RC103-433	CF1/4-330K	ASE	4700-15-3303	1
R46	RES, C, 1/4W, 5%, 180K RC103-418	CF1/4-180K	ASE	4700-15-1803	1
R48	RES, C, 1/4W, 5%, 30K RC103-330	CF1/4-30K	ASE	4700-15-3002	1
R51	RES, C, 1/4W, 10%, 10M RC104-610	CB1061	A-B	4700-16-1005	1
R52	RES, C, 1/4W, 5%, 470K RC103-447	CF1/4-470K	ASE	4700-15-4703	1
R55	RES, C, 1/4W, 5%, 820K RC103-482	CF1/4-820K	ASE	4700-15-8203	1
R59	RES, C, 1/4W, 5%, 470 RC103-147	CF1/4-470	ASE	4700-15-4700	1
R62	RES, MF, 1/8W, 1%, 100K RF214-100	MF55K-100K	ASE	4701-03-1003	1
R27	RES, C, 1/4W, 5%, 100K	CF 1/4-100K	ASE	4700-15-1003	1
<b>WAVETEK PARTS LIST</b>		TITLE SWEEP RATE, M101B	ASSEMBLY NO. 1114-00-0267  PAGE: 5		REV B

REFERENCE DESIGNATORS	PART DESCRIPTION	ORIG-MFGR-PART-NO	MFGR	WAVETEK NO.	QTY
C06 C08	CAP, G-C, 2.0PF, 10% CG101-220	GC-2.0PF	G-C	1510-40-0020	2
C06 C08	CAP, G-C, 2.0PF, 10% CG101-220	GC-2.0PF	G-C	1510-40-0020	2
C12 C14	CAP, TANT, .47MF, 50V CE113-447	935	TRW	1510-21-9470	2
C13 C99	CAP, F. T., 470PF CF101-147	FA5C-4712	A-B	1510-30-0471	2
CR01 CR02 CR03 CR04 CR05 CR06 CR07 CR08 CR09 CR10 CR11 CR12 CR13 CR14 CR15 CR16 CR17 CR18 CR19 CR20	DIODE DG109-140	1N414B	FCD	4807-01-0914	20
IC01 IC02 IC03	DUAL OP AMP, RAYTHEON IC000-027	RC4558DN	RAY	7000-45-5801	3
Q01	TRANS-GA042-500	2N4250	FCD	4901-04-2500	1
Q02	TRANS GA050-880	2N508B	MOT	4901-05-0880	1
R01 R49	RES, MF, 1/8W, 1%, 2.74K RF212-274	MF55K-2.74K	ASE	4701-03-2741	2
R02 R48	POT, 2K, RP130-220	B9PR2K	BEK	4610-00-2202	2
R03 R47	RES, MF, 1/8W, 1%, 15K RF213-150	MF55K-15K	ASE	4701-03-1502	2
<b>WAVETEK PARTS LIST</b>	TITLE SWEEP DRIVE, M102A	ASSEMBLY NO. 1114-00-0268		REV B	
		PAGE: 1			

REFERENCE DESIGNATORS	PART DESCRIPTION	ORIG-MFGR-PART-NO	MFGR	WAVETEK NO.	QTY
R04 R51	RES, MF, 1/8W, 1%, 10K RF213-100	MF55K10K	ASE	4701-03-1002	2
R5 R50	RES, MF, 1/8W, 1%, 4.87K RF212-487	MF55K-4.87K	ASE	4701-03-4871	2
R07 R08 R09 R10 R24 R25 R26 R27 R53 R54 R55 R56 R70 R71 R72 R73	RES, C, 1/4W, 5%, 2.2K RC103-222	CF1/4-2.2K	ASE	4700-15-2201	16
R11 R12 R13 R14 R15 R28 R29 R30 R57 R58 R59 R60 R61 R74 R75 R76 R77	POT, 100K, RP144-410	91WR100K	BEK	4610-00-4104	17
R16 R40 R62 R87 R88	RES, C, 1/4W, 5%, 82K RC103-382	CF1/4-82K	ASE	4700-15-8202	5
R17 R19 R21 R23 R32 R34 R36 R63 R64 R67 R69 R79	RES, C, 1/4W, 5%, 220K RC103-422	CF1/4220K	ASE	4700-15-2203	12
R18 R20 R22 R31 R33 R35	RES, C, 1/4W, 5%, 680K RC103-468	CF1/4-680K	ASE	4700-15-6803	6
R37 R38 R39 R41 R85 R90	RES, C, 1/4W, 5%, 100K RC103-410	CF1/4-100K	ASE	4700-15-1003	6
R42 R89	POT, 20K, RP130-320	B9PR20K	BEK	4610-00-2203	2
R81 R82 R83	RES, C, 1/4W, 5%, 120K	CF1/4-120K	ASE	4700-15-1203	3
R84	RES, C, 1/4W, 5%, 750K	CF1/4-750K	ASE	4700-15-7503	1
R86	RES, C, 1/4W, 5%, 10K	CF1/4-10K	ASE	4700-15-1002	1
<b>WAVETEK PARTS LIST</b>	TITLE SWEEP DRIVE, M102A	ASSEMBLY NO. 1114-00-0268		REV B	
		PAGE: 2			



REFERENCE DESIGNATORS	PART DESCRIPTION	DRIG-MFGR-PART-NO	MFGR	WAVETEK NO.	QTY
C01 C02 C03 C04 C05 C06 C07 C08 C10	CAP, F. T., 6.8PF CF102-R68	FA5C-6892	A-B	1510-30-1689	9
C09 C11	CAP, Q-C, 2.0PF, 10% CG101-220	QC-2.0PF	Q-C	1510-40-0020	2
C12 C13	CAP, CER, .05MF, 100V CD103-350	TG-S50	SPR	1510-10-2503	2
C14 C15	CAP, F. T., 470PF CF101-147	FA5C-4712	A-B	1510-30-0471	2
CRO1 CRO2 CRO3 CRO4 CRO5 CRO6 CRO7 CRO8 CRO9 CRO10 CRO11 CRO12 CRO13 CRO14 CRO15 CRO16 CRO17 CRO18	DIODE DG109-140	1N4148	FCD	4807-01-0914	18
IC01 IC02 IC03 IC04	DUAL OP AMP, RAYTHEON IC000-027	RC4558DN	RAY	7000-45-5801	4
R01 R02 R03 R04 R05 R06	RES, MF, 1/8W, 1%, 499 RF211-499	MF55K-499	ASE	4701-03-4990	6
R07 R08 R09 R10 R45 R82	POT, 20K, RP130-320	B9PR20K	BEK	4610-00-2203	6
R11 R12 R13 R14	RES, C, 1/4W, 5%, 330 RC103-133	CF1/4-330	ASE	4700-15-3300	4
R15 R16 R17 R18 R29 R30 R31 R32 R46 R47 R48 R49 R63 R64 R65 R66	RES, C, 1/4W, 5%, 2.2K RC103-222	CF1/4-2.2K	ASE	4700-15-2201	16
<b>WAVETEK PARTS LIST</b>	TITLE SWEEP DRIVE, M103A	ASSEMBLY NO. 1114-00-0269  PAGE: 1	REV		

REFERENCE DESIGNATORS	PART DESCRIPTION	DRIG-MFGR-PART-NO	MFGR	WAVETEK NO.	QTY
R19 R20 R21 R22 R23 R33 R34 R35 R50 R51 R52 R53 R54 R67 R68 R69 R70	POT, 100K, RP144-410	91WR100K	BEK	4610-00-4104	17
R24 R43 R55	RES, C, 1/4W, 5%, 82K RC103-382	CF1/4-82K	ASE	4700-15-8202	3
R25 R26 R62 R71 R73	RES, C, 1/4W, 5%, 220K RC103-422	CF1/4220K	ASE	4700-15-2203	5
R27 R28 R36 R37 R38 R75 R76	RES, C, 1/4W, 5%, 330K RC103-433	CF1/4-330K	ASE	4700-15-3303	7
R39	RES, C, 1/4W, 5%, 750K RC103-475	CF1/4-750K	ASE	4700-15-7503	1
R40 R41 R44 R77 R78 R79	RES, C, 1/4W, 5%, 100K RC103-410	CF1/4-100K	ASE	4700-15-1003	6
R42	RES, C, 1/4W, 5%, 10K RC103-310	CF1/4-10K	ASE	4700-15-1002	1
R56 R58 R72 R74 R80 R81	RES, C, 1/4W, 5%, 150K RC103-415	CF1/4-150K	ASE	4700-15-1503	6
R57 R59 R61	RES, 1/4W, 5%, 470K RC103-447AB	CB4745	A-B	4705-15-4703	3
R60	RES, C, 1/4W, 5%, 180K RC103-418	CF1/4-180K	ASE	4700-15-1803	1
<b>WAVETEK PARTS LIST</b>	TITLE SWEEP DRIVE, M103A	ASSEMBLY NO. 1114-00-0269  PAGE: 2	REV		

REFERENCE DESIGNATORS	PART DESCRIPTION	ORIG-MFGR-PART-NO	MFGR	WAVETEK NO.	QTY
C01 C02 C03 C05 C07 C08 C09	CAP, CER, .02UF, 50V	TG-S20	SPR	1510-10-2203	7
C04	CAP, TANT, .47MF, 50V CE113-447	935	TRW	1510-21-9470	1
C06 C10	CAP, CER, 360PF, 1KV CD102-136	60U361M	MDC	1510-10-1361	2
C11 C12 C13 C14 C15 C16 C17 C20 C21 C23 C24	CAP, F. T., 6.8PF CF102-R68	FA5C-6892	A-B	1510-30-1689	11
C18 C19	CAP, F. T., 470PF CF101-147	FA5C-4712	A-B	1510-30-0471	2
CR01 CR02 CR03	DIODE DG109-140	1N4148	FGD	4807-01-0914	3
IC01 IC03	IC, IC000-002	N5741CV	SIG	7000-57-4100	2
IC02	DUAL OP AMP, RAYTHEON IC000-027	RC455BDN	RAY	7000-45-5801	1
G01 G02	TRANS GA054-580	2N5458	MOT	4901-05-4580	2
G03 G04 G05	TRANS GA038-541	2N3854A	G-E	4901-03-8541	3
G06	TRANS GA054-610	2N5461	MOT	4901-05-4610	1
R01	RES, C, 1/4W, 5%, 560K RC103-456	CF1/4-560K	ASE	4700-15-5603	1
R02 R12 R23	POT, 20K, RP130-320	B9PR20K	BEK	4610-00-2203	3
<b>WAVETEK PARTS LIST</b>		TITLE LEVELER, M104A	ASSEMBLY NO. 1114-00-0270  PAGE: 1		REV A

REFERENCE DESIGNATORS	PART DESCRIPTION	ORIG-MFGR-PART-NO	MFGR	WAVETEK NO.	QTY
R03 R10* R29*	RES, C, 1/4W, 5%, 470K RC103-447	CF1/4-470K	ASE	4700-15-4703	3
R04 R06 R22 R25 R37 R38	RES, C, 1/4W, 5%, 47K RC103-347	CF1/4-47K	ASE	4700-15-4702	6
R05 R39	RES, C, 1/4W, 5%, 10M RC103-610	CB1065	A-B	4700-15-1005	2
R07 R26	RES, C, 1/4W, 5%, 1M RC103-510	CF1/4-1M	ASE	4700-15-1004	2
R08 R27	RES, C, 1/4W, 5%, 2.2M RC103-522	CF1/4-2.2M	ASE	4700-15-2204	2
R09 R28	RES, C, 1/4W, 5%, 1K RC103-210	CF1/4-1K	ASE	4700-15-1001	2
R11	POT, 1M, RP130-510	B9PR1M	BEK	4610-00-2105	1
R13	RES, C, 1/4W, 5%, 33K RC103-333	CF1/4-33K	ASE	4700-15-3302	1
R14	RES, C, 1/8W, 5%, 220K RC101-422	CF1/8-220K	ASE	4700-05-2203	1
R15	RES, C, 1/4W, 5%, 120K RC103-412	CF1/4-120K	ASE	4700-15-1203	1
R16	RES, C, 1/4W, 5%, 360K RC103-436	CF1/4-360K	ASE	4700-15-3603	1
R17	RES, C, 1/4W, 5%, 12K RC103-312	CF1/4-12K	ASE	4700-15-1202	1
<b>WAVETEK PARTS LIST</b>		TITLE LEVELER, M104A	ASSEMBLY NO. 1114-00-0270  PAGE: 2		REV A

REFERENCE DESIGNATORS	PART DESCRIPTION	ORIG-MFGR-PART-NO	MFGR	WAVETEK NO.	QTY
R18	POT, 5K, RP130-250	89PR5K	BEK	4610-00-2502	1
R19	RES, C, 1/4W, 5%, 330K RC103-433	CF1/4-330K	ASE	4700-15-3303	1
R20 R36	RES, C, 1/4W, 5%, 10K RC103-310	CF1/4-10K	ASE	4700-15-1002	2
R21	RES, C, 1/4W, 5%, 200K RC103-420	CF1/4-200K	ASE	4700-15-2003	1
R24	RES, C, 1/4W, 5%, 270K RC103-427	CF1/4-270K	ASE	4700-15-2703	1
R30*	RES, C, 1/4W, 5%, 7.5K RC103-275	CF1/4-7.5K	ASE	4700-15-7501	1
R31	RES, C, 1/4W, 5%, 2.2K RC103-222	CF1/4-2.2K	ASE	4700-15-2201	1
R32	RES, C, 1/4W, 5%, 4.7K RC103-247	CF1/4-4.7K	ASE	4700-15-4701	1
R33	RES, C, 1/4W, 5%, 6.8K RC103-268	CF1/4-6.8K	ASE	4700-15-6801	1
R34	RES, C, 1/4W, 5%, 100 RC103-110	CF1/4-100	ASE	4700-15-1000	1
R35	RES, C, 1/4W, 5%, 68K RC103-368	CF1/4-68K	ASE	4700-15-6802	1
R40	RES, C, 1/4W, 5%, 200	CF1/4-200	ASE	4700-15-2000	1
<b>WAVETEK PARTS LIST</b>	TITLE LEVELER, M104A	ASSEMBLY NO. 1114-00-0270  PAGE: 3		REV A	

REFERENCE DESIGNATORS	PART DESCRIPTION	ORIG-MFGR-PART-NO	MFGR	WAVETEK NO.	QTY
C01 C03 C05 C16 C24 C26	CAP, F. T., 6.8PF CF102-R68	FA5C-6892	A-B	1510-30-1689	6
C02 C04 C06 C25 C27	CAP, CER., .002MF, 1KV CD102-220	5GAD20	SPR	1510-10-1202	5
C07 C10 C22 C28	CAP, CER., .01MF, 100V CD103-310	68U103M	MDC	1510-10-2103	4
C08 C29	CAP, TANT, 10MF, 25V CE120-010	162D106X0025DD2	SPR	1510-21-7100	2
C09 C23	CAP, CER., .001MFD, 1KV CD102-210	5GAD10	SPR	1510-10-1102	2
C11 C14 C15 C17 C18 C21	CAP, CER., .02UF, 50V	TG-S20	SPR	1510-10-2203	6
C12 C13 C19 C20	CAP, CER, 100PF, 1KV CD102-110	60U101M	MDC	1510-10-1101	4
C30 C31 C32 C33 C35 C37 C38	CAP, F. T., 470PF CF101-147	FA5C-4712	A-B	1510-30-0471	7
C34 C36	CAP, ELECT, 100MF, 25V CE105-110	TE1211	SPR	1510-20-4101	2
CR1	DIODE DR000-001	1N4004	P-C	4806-01-4004	1
IC1 IC2	IC, IC000-030	LM318N	NAT	7000-03-1800	2
L1 L2	CHOK, 10.0MH, 10% LA005-010	OBN100K	ASE	1810-03-0100	2
<b>WAVETEK PARTS LIST</b>		TITLE MKR ADDER, M105	ASSEMBLY NO. 1114-00-0137  PAGE: 1		REV C

REFERENCE DESIGNATORS	PART DESCRIPTION	ORIG-MFGR-PART-NO	MFGR	WAVETEK NO.	QTY
G01 G02 G03 G04 G05	TRANS GA050-880	2N5088	MDT	4901-05-0880	5
G06 G08 G15 G17	TRANS GA038-541	2N3854A	G-E	4901-03-8541	4
G07 G09 G10 G11 G12 G13	TRANS GA054-580	2N5458	MDT	4901-05-4580	6
G14 G16	TRANS GB000-009	MPS3702	MDT	4902-03-7020	2
R01 R04 R07 R47 R50	RES, C, 1/4W, 5%, 5.6K RC103-256	CF1/4-5.6K	ASE	4700-15-5601	5
R02 R05 R08 R46 R48	RES, C, 1/4W, 5%, 22K RC103-322	CF1/422K	ASE	4700-15-2202	5
R03 R06 R09 R18 R34 R45 R49	RES, C, 1/4W, 5%, 270 RC103-127	CF1/4-270	ASE	4700-15-2700	7
R10 R41	RES, C, 1/4W, 5%, 4.7K RC103-247	CF1/4-4.7K	ASE	4700-15-4701	2
R11 R12 R16 R36 R39 R40	RES, C, 1/4W, 10%, 10M RC104-610	CB1061	A-B	4700-16-1005	6
R13 R17 R19 R24 R25 R29 R33 R38	RES, C, 1/4W, 5%, 10K RC103-310	CF1/4-10K	ASE	4700-15-1002	8
R14 R21 R22 R27 R32 R37	RES, C, 1/4W, 5%, 1K RC103-210	CF1/4-1K	ASE	4700-15-1001	6
R15 R35	RES, C, 1/4W, 5%, 220K RC103-422	CF1/4220K	ASE	4700-15-2203	2
<b>WAVETEK PARTS LIST</b>		TITLE MKR ADDER, M105	ASSEMBLY NO. 1114-00-0137  PAGE: 2		REV C

REFERENCE DESIGNATORS	PART DESCRIPTION	ORIG-MFGR-PART-NO	MFGR	WAVETEK NO.	QTY	
R20 R23 R26 R31	RES. C, 1/4W, 5%, 680 RC103-168	CF1/4-680	ASE	4700-15-6800	4	
R28	RES. C, 1/4W, 5%, 100K RC103-410	CF1/4-100K	ASE	4700-15-1003	1	
R30	POT. 20K RP124-320	WA260325-203MA	A-B	4610-10-7203	1	
R42 R43 R44	RES. C, 1/4W, 10%, 2. 2M RC104-522AB	CB2251	A-B	4705-16-2204	3	
R51 R52	RES. C, 1/4W, 5%, 3. 3K RC103-233	CF1/4-3. 3K	ASE	4700-15-3301	2	
<b>WAVETEK</b> <b>PARTS LIST</b>		TITLE MKR ADDER, M105		ASSEMBLY NO. 1114-00-0137  PAGE: 3		REV C

REFERENCE DESIGNATORS	PART DESCRIPTION	ORIG-MFGR-PART-NO	MFGR	WAVETEK NO.	QTY
C01 C03	CAP, F. T., 470PF CF101-147	FA5C-4712	A-B	1510-30-0471	2
C02 C15	CAP, F. T., 6.8PF CF102-R68	FA5C-6892	A-B	1510-30-1689	2
C04 C05 C24 C26 C27 C29 C30	CAP, TANT, .47MF, 50V CE113-447	935	TRW	1510-21-9470	7
C06	CAP, MON, 1MF, 50V, 20%	3420-050-E105M	AER	1510-11-3105	1
C07 C08 C09 C10 C14 C16 C22 C33	CAP, FT, CER, 100PF, 20% CF104-110	4420-100PF	AER	1510-30-3101	8
C11 C12 C20	CAP, G-C, 10PF, 10%, CG101-310	GC-10PF	G-C	1510-40-0100	3
C13 C21	CAP, CER, 120PF, 1KV CD102-112	60U121M	MDC	1510-10-1121	2
C17	CAP, G. C., .47PF CG101-147	GC-.47PF	G-C	1510-40-0478	1
C18	CAP, CHIP, 1PF, 100V CC101-R10	3BN100S1ROC(S)	VAR	1510-00-0010	1
C19	CAP, G. C., 3PF CG101-230	GC-3PF	G-C	1510-40-0030	1
C23	CAP, G. C., 1PF CG101-210	GC-1PF	G-C	1510-40-0010	1
C25 C28 C31	CAP, CER, F. T. 1000PF CF112-210	54-794-010-102P	SPEC	1510-30-8102	3
<b>WAVETEK PARTS LIST</b>		TITLE SWP OSC, M109	ASSEMBLY NO. 1114-00-0138		REV E
			PAGE: 1		

REFERENCE DESIGNATORS	PART DESCRIPTION	ORIG-MFGR-PART-NO	MFGR	WAVETEK NO.	QTY
C32	CAP, G-C, 2.0PF, 10% CG101-220	GC-2.0PF	G-C	1510-40-0020	1
CR01 CR02 CR03 CR04	DIODE DC000-008	BB205	APX	4803-02-0004	4
CR05 CR09	DIODE DP000-040	MA47980	M-A	4805-02-0001	2
CR06 CR10	DIODE DG100-821	1N82A6	G-I	4807-01-0082	2
CR07 CR08 CR11	DIODE DG109-140	1N4148	FCD	4807-01-0914	3
IC1 IC2 IC3	IC, IC000-004	N5741T	SIG	7000-57-4101	3
J1	CONN JF000-005	37JR116-1	S-C	2110-03-0002	1
L01 L17 L18	TORRID, 10 TURN	LA009-010-1	HYT	1810-05-0004	3
L02 L03	FERRITE CHOKE LA009-010	T1255-2	HYT	1810-05-0002	2
L04 L07 L09 L11 L12 L13 L15 L19	RF CHOKE	CHOKE	W-I	1819-99-9999	8
L05 L08 L10 L14	CHOKE .22MH 10% LA005-R02	08NR22K	ASE	1810-03-0228	4
L06	CHOKE, .22MH, 10% LA008-R02	506-000022V1	SYS	1810-04-0228	1
L16	TORRID, 4 TURN	LA009-004-1	HYT	1810-05-0003	1
Q1	TRANS QA054-610	2N5461	MDT	4901-05-4610	1
<b>WAVETEK PARTS LIST</b>		TITLE SWP OSC, M109	ASSEMBLY NO. 1114-00-0138		REV E
			PAGE: 2		

REFERENCE DESIGNATORS	PART DESCRIPTION	ORIG-MFGR-PART-NO	MFGR	WAVETEK NO.	QTY
Q2	TRANS QB000-013	A430	APX	4902-00-4300	1
Q3 Q6	TRANS GA050-530	2N5053	APX	4901-05-0530	2
Q4	TRANS GA03B-541	2N3854A	G-E	4901-03-8541	1
Q5	TRANS GA051-090	2N5109	SSS	4901-05-1090	1
R01 R04 R16 R38	RES. C, 1/4W, 5%, 2.2K RC103-222	CF1/4-2.2K	ASE	4700-15-2201	4
R03	RES. C, 1/4W, 5%, 10M RC103-610	CB1065	A-B	4700-15-1005	1
R02 R11 R17 R22 R27 R30 R37 R40	RES. C, 1/4W, 5%, 10K RC103-310	CF1/4-10K	ASE	4700-15-1002	8
R05	RES. C, 1/4W, 5%, 680 RC103-168	CF1/4-680	ASE	4700-15-6800	1
R06	RES. C, 1/4W, 5%, 8.2K RC103-282	CF1/4-8.2K	ASE	4700-15-8201	1
R07 R08	RES. C, 1/4W, 5%, 1K RC103-210	CF1/4-1K	ASE	4700-15-1001	2
R09 R12 R31 R33	RES. C, 1/4W, 5%, 4.7K RC103-247	CF1/4-4.7K	ASE	4700-15-4701	4
R10 R32	RES. C, 1/4W, 5%, 470 RC103-147	CF1/4-470	ASE	4700-15-4700	2
R13 R34	RES. C, 1/4W, 5%, 560 RC103-156	CF1/4-560	ASE	4700-15-5600	2
<b>WAVETEK PARTS LIST</b>		TITLE SWP OSC, M109	ASSEMBLY NO. 1114-00-0138		REV E
			PAGE: 3		

REFERENCE DESIGNATORS	PART DESCRIPTION	ORIG-MFGR-PART-NO	MFGR	WAVETEK NO.	QTY
R14 R35	POT, 20K, RP129-320	360S203B	CTS	4610-00-1203	2
R15	RES. C, 1/4W, 5%, 470K RC103-447	CF1/4-470K	ASE	4700-15-4703	1
R18	RES. C, 1/4W, 5%, 270 RC103-127	CF1/4-270	ASE	4700-15-2700	1
R19 R41	RES. C, 1/4W, 5%, 47 RC103-047	CF1/4-47	ASE	4700-15-4709	2
R20 R26	RES. C, 1/4W, 5%, 3.3K RC103-233	CF1/4-3.3K	ASE	4700-15-3301	2
R21 R24	RES. C, 1/4W, 5%, 15K RC103-315	CF1/4-15K	ASE	4700-15-1502	2
R23	RES. C, 1/4W, 5%, 91K RC103-391	CF1/4-91K	ASE	4700-15-9102	1
R25 R39	RES. C, 1/4W, 5%, 47K RC103-347	CF1/4-47K	ASE	4700-15-4702	2
R28	RES. C, 1/2W, 5%, 150 RC105-115	CF1/2-150	ASE	4700-25-1500	1
R29	RES. C, 1/4W, 5%, 3.9K RC103-239	CF1/4-3.9K	ASE	4700-15-3901	1
R36	RES. C, 1/4W, 5%, 100K RC103-410	CF1/4-100K	ASE	4700-15-1003	1
<b>WAVETEK PARTS LIST</b>		TITLE SWP OSC, M109	ASSEMBLY NO. 1114-00-0138		REV E
			PAGE: 4		

REFERENCE DESIGNATORS	PART DESCRIPTION	ORIG-MFGR-PART-NO	MFGR	WAVETEK NO.	QTY
R42	RES, C, 1/4W, 5%, 10 RC103-010	CF1/4-10	ASE	4700-15-1009	1
23	RF MIXER ASSY	A500-319	W-I	1219-00-0055	1
22	PRE-AMP, A529-012	A529-012	W-I	1219-00-0070	1

<b>WAVETEK PARTS LIST</b>	TITLE SWP OSC, M109	ASSEMBLY NO. 1114-00-0138	REV E
		PAGE: 5	

REFERENCE DESIGNATORS	PART DESCRIPTION	ORIG-MFGR-PART-NO	MFGR	WAVETEK NO.	QTY
C101	CAP, G-C, 2.4PF, 10% CG101-224	GC-2.4PF	G-C	1510-40-0249	1
CR101 CR102 CR103 CR104	DIODE DG000-009	5082-2835	H-P	4809-02-0002	4
T101	RF XFMR FROM: 1813-00-0007	TR001-003	W-I	1210-40-0003	1
T102	RF XFMR FROM: 1813-00-0008	TR002-001	W-I	1210-41-0001	1

<b>WAVETEK PARTS LIST</b>	TITLE RF MIXER ASSY	ASSEMBLY NO. 1219-00-0055	REV A
		PAGE: 1	



REFERENCE DESIGNATORS	PART DESCRIPTION	ORIG-MFGR-PART-NO	MFGR	WAVETEK NO.	QTY
C201 C207	CAP, TANT, .47MF, 50V CE113-447	935	TRW	1510-21-9470	2
C202 C204 C206	CAP, FT, 500PF, 20%250V CF104-150	4420-500PF	AER	1510-30-3501	3
C203	CAP, ELECT, 1MF, 25V CE120-001	162D105X9025BC2	SPR	1510-21-7010	1
C205	CAP, Q-C, 2.0PF, 10% CG101-220	QC-2.0PF	Q-C	1510-40-0020	1
CR201	DIODE DB000-001	HW6.8B	MSP	4801-02-0001	1
CR202	DIODE DC000-005	BB141A	ITT	4889-00-0001	1
L201 L203	RF CHOKE	CHOKE	W-I	1819-99-9999	2
L204 L206	FERRITE CHOKE LA009-010	T1255-2	HYT	1810-05-0002	2
Q201 Q202	TRANS QA050-530	2N5053	APX	4901-05-0530	2
Q203	TRANS QB000-009	MPS3702	MDT	4902-03-7020	1
Q204	TRANS QB000-013	A430	APX	4902-00-4300	1
R201	RES, C, 1/4W, 5%, 100 RC103-110	CF1/4-100	ASE	4700-15-1000	1
R202	RES, C, 1/4W, 5%, 330 RC103-133	CF1/4-330	ASE	4700-15-3300	1
<b>WAVETEK PARTS LIST</b>		TITLE PRE-AMP, A529-012	ASSEMBLY NO. 1219-00-0070		REV D
			PAGE: 1		

REFERENCE DESIGNATORS	PART DESCRIPTION	ORIG-MFGR-PART-NO	MFGR	WAVETEK NO.	QTY
R203	RES, C, 1/4W, 5%, 470 RC103-147	CF1/4-470	ASE	4700-15-4700	1
R204	RES, C, 1/4W, 5%, 2.7K RC103-227	CF1/4-2.7K	ASE	4700-15-2701	1
R205	RES, C, 1/4W, 5%, 27K RC103-327	CF1/4-27K	ASE	4700-15-2702	1
R206 R208 R209	RES, C, 1/4W, 5%, 47 RC103-047	CF1/4-47	ASE	4700-15-4709	3
R207	RES, C, 1/4W, 5%, 4.7K RC103-247	CF1/4-4.7K	ASE	4700-15-4701	1
<b>WAVETEK PARTS LIST</b>		TITLE PRE-AMP, A529-012	ASSEMBLY NO. 1219-00-0070		REV D
			PAGE: 2		

REFERENCE DESIGNATORS	PART DESCRIPTION	ORIG-MFGR-PART-NO	MFGR	WAVETEK NO.	QTY
C01 C02 C03 C05 C42 C43 C48 C49 C50 C52	CAP, F. T., 470PF CF101-147	FA5C-4712	A-B	1510-30-0471	10
C04 C33 C45 C51	CAP, F. T., 6.8PF CF102-R68	FA5C-6892	A-B	1510-30-1689	4
C06 C07 C31 C32 C34 C35 C46 C47	CAP, TANT, 10MF, 25V CE120-010	162D106X0025DD2	SPR	1510-21-7100	8
C08	CAP, M. C., .47PF CG102-147	MC-.47PF	G-C	1510-40-1478	1
C09 C10 C11 C12 C13 C14 C15 C16 C17 C19 C20 C21 C24 C25 C26 C27 C28 C29 C30 C36 C37 C39 C40 C41 C44	CAP, FT, CER, 100PF, 20% CF104-110	4420-100PF	AER	1510-30-3101	25
C18	CAP, CER, F. T., 10PF CF119-010	4420-10PF	AVX	1510-31-5100	1
C22	CAP, MC, 1.1PF, 10% CG102-211	MC1.1PF	G-C	1510-40-1119	1
C23	CAP, M. C., .75PF CG102-175	MC-.75PF	G-C	1510-40-1758	1
C38	CAP., CHIP 75PF 10%	100B750KP500	ATC	1510-00-2750	1
CR01 CR02 CR03 CR04 CR05 CR12 CR13 CR14 CR15	DIDDE DC000-008	BB205	APX	4803-02-0004	9
<b>WAVETEK PARTS LIST</b>		TITLE SWP OSC, M110	ASSEMBLY NO. 1114-00-0139		REV F
			PAGE: 1		

REFERENCE DESIGNATORS	PART DESCRIPTION	ORIG-MFGR-PART-NO	MFGR	WAVETEK NO.	QTY
CR06 CR07 CR08 CR09 CR10 CR11	DIODE DP000-060	MA47047	M-A	4805-02-0003	6
CR16 CR17	DIODE, VARACTOR DC000-010	DKV6550B	AIN	4803-02-0006	2
CR18 CR19 CR24 CR25	DIODE DP000-040	MA47980	M-A	4805-02-0001	4
CR20 CR21 CR22 CR23	DIODE DR000-001	1N4004	P-C	4806-01-4004	4
J1 J2	CONN JF000-005	37JR116-1	S-C	2110-03-0002	2
L01 L02 L05 L06 L16	CHOKE .22MH 10% LA005-R02	08NR22K	ASE	1810-03-0228	5
L03 L04 L07 L08 L10 L11 L12 L13 L14 L15	RF CHOKE	CHOKE	W-I	1819-99-9999	10
L09	CHOKE .10MH 10% LA005-R01	08NR10K	ASE	1810-03-0019	1
L17	TORRID, 10 TURN	LA009-010-1	HYT	1810-05-0004	1
Q01	TRANS QB000-034	BFR94	APX	4902-00-0940	1
Q02	TRANS QB000-013	A430	APX	4902-00-4300	1
Q03 Q04 Q06 Q08 Q12	TRANS QB000-009	MFS3702	MOT	4902-03-7020	5
Q05	TRANS QB000-033	MRF905	MOT	4902-00-9050	1
Q07 Q13	TRANS GA054-610	2N5461	MOT	4901-05-4610	2
<b>WAVETEK PARTS LIST</b>		TITLE SWP OSC, M110	ASSEMBLY NO. 1114-00-0139		REV F
			PAGE: 2		

REFERENCE DESIGNATORS	PART DESCRIPTION	ORIG-MFGR-PART-NO	MFGR	WAVETEK NO.	QTY	
Q09 Q10 Q11	TRANS QA03B-541	2N3854A	G-E	4901-03-8541	3	
R01 R03 R34	RES, C, 1/4W, 5%, 100 RC103-110	CF1/4-100	ASE	4700-15-1000	3	
R02 R49	RES, C, 1/4W, 5%, 330 RC103-133	CF1/4-330	ASE	4700-15-3300	2	
R04 R27	RES, C, 1/4W, 5%, 22 RC103-022	CF1/4-22	ASE	4700-15-2209	2	
R05 R22	RES, C, 1/4W, 5%, 680 RC103-168	CF1/4-680	ASE	4700-15-6800	2	
R06 R20	RES, C, 1/4W, 5%, 8.2K RC103-282	CF1/4-8.2K	ASE	4700-15-8201	2	
R07 R21	RES, C, 1/4W, 5%, 4.7K RC103-247	CF1/4-4.7K	ASE	4700-15-4701	2	
R08 R09 R10 R17 R18 R19 R23 R25	RES, C, 1/4W, 5%, 1K RC103-210	CF1/4-1K	ASE	4700-15-1001	8	
R11	RES, C, 1/4W, 5%, 470 RC103-147	CF1/4-470	ASE	4700-15-4700	1	
R12	RES, C, 1/4W, 5%, 5.6K RC103-256	CF1/4-5.6K	ASE	4700-15-5601	1	
R13 R14 R15 R33 R37 R38 R39 R40 R43 R44	RES, C, 1/4W, 5%, 2.2K RC103-222	CF1/4-2.2K	ASE	4700-15-2201	10	
R16	RES, C, 1/4 W, 5%, 110	CB1115	A-B	4705-15-1100	1	
<b>WAVETEK PARTS LIST</b>		TITLE SWP OSC, M110		ASSEMBLY NO. 1114-00-0139  PAGE: 3		REV F

REFERENCE DESIGNATORS	PART DESCRIPTION	ORIG-MFGR-PART-NO	MFGR	WAVETEK NO.	QTY	
R24 R26 R50	RES, C, 1/4W, 5%, 10K RC103-310	CF1/4-10K	ASE	4700-15-1002	3	
R28	RES, C, 1/4W, 5%, 15	CB1505	A-B	4705-15-1509	1	
R29	RES, C, 1W, 10%, 470 RC108-147	GB4711	A-B	4700-36-4700	1	
R30	RES, C, 1/8 W, 5%, 680	BB6815	A-B	4705-05-6800	1	
R31	RES, C, 1/4W, 5%, 560 RC103-156	CF1/4-560	ASE	4700-15-5600	1	
R32	RES, C, 1/4 W, 10%, 2.7K	CB2721	A-B	4705-16-2701	1	
R35 R36 R41 R42	RES, C, 1/4W, 5%, 27K RC103-327	CF1/4-27K	ASE	4700-15-2702	4	
R45	RES, C, 1/4W, 5%, 22K RC103-322	CF1/422K	ASE	4700-15-2202	1	
R46 R52	RES, C, 1/4W, 5%, 100K RC103-410	CF1/4-100K	ASE	4700-15-1003	2	
R47	RES, C, 1/4W, 10%, 3.3M RC104-533	CB3351	A-B	4700-16-3304	1	
R48	RES, C, 1/4W, 10%, 22M RC104-622	CB2261	A-B	4700-16-2205	1	
R51	RES, C, 1/4W, 5%, 1M	CF1/4-1M	ASE	4700-15-1004	1	
R53	RES, C, 1/4W, 5%, 47K	CF1/4-47K	ASE	4700-15-4702	1	
R54	RES, C, 1/4W, 10%, 10M	CB1061	A-B	4700-16-1005	1	
<b>WAVETEK PARTS LIST</b>		TITLE SWP OSC, M110		ASSEMBLY NO. 1114-00-0139  PAGE: 4		REV F

REFERENCE DESIGNATORS	PART DESCRIPTION	ORIG-MFGR-PART-NO	MFGR	WAVETEK NO.	QTY
C01 C05 C06 C10 C11 C15 C16 C18 C19 C22 C23 C27 C28 C32 C33 C37	CAP, FT, 500PF, 20%250V CF104-150	4420-500PF	AER	1510-30-3501	16
C02 C03 C07 C09 C12 C14 C17 C20 C24 C26 C29 C30 C34	CAP, ELECT, 1MF, 25V CE120-001	162D105X9025BC2	SPR	1510-21-7010	13
C04 C08 C13 C21 C25 C31	CAP., VAR., 1.5/.25 PF	273-0001-001	JON	1510-70-7259	6
C35 C36	CAP, CER, F. T., 3.5PF CF117-R35	4420-3.5PF	AVX	1510-31-3359	2
CR1 CR3 CR4 CR5	DIODE PIN	5082-3081	H-P	4805-02-0004	4
CRO2	DIODE, 1N82 MITEK ONLY	1N82	MTK	4807-03-0003	1
CRO6	DIODE, MK904	MK904	MTK	4807-03-0004	1
CRO7	DIODE, 1N82AG, SEMTEX ONLY	1N82AG(SMTX)	SEMTEX	4807-03-0005	1
J1 J2	CONN JF000-005	37JR116-1	S-C	2110-03-0002	2
L1 L4 L5	CHOKE, 1MH, 10% LA005-R10	0BN1ROK	ASE	1810-03-0010	3
L02 L09	TORRID, 10 TURN	LA009-010-1	HYT	1810-05-0004	2
L3 L6 L8	CHOKE, 33MH, 10% LA005-033	0BN330	ASE	1810-03-0330	3
<b>WAVETEK PARTS LIST</b>		TITLE OUTPUT AMPLIFIER MA111	ASSEMBLY NO. 111B-00-0014  PAGE: 1		REV I

REFERENCE DESIGNATORS	PART DESCRIPTION	ORIG-MFGR-PART-NO	MFGR	WAVETEK NO.	QTY
L7	CHOKE, 22MH, 10% LA005-022	0BN220	ASE	1810-03-0220	1
Q1 Q2 Q3 Q4	TRANS MCRWV	NEO2135	NEC	4902-02-1350	4
Q5 Q6	TRANS PWR	MSC80264	MSC	4902-80-2640	2
R01	RES, C, 1/BW, 5%, 120	BB1215	A-B	4705-05-1200	1
R02 R08 R10	RES, C, 1/4W, 5%, 470 RC103-147	CF1/4-470	ASE	4700-15-4700	3
R03 R07 R09 R11 R12	RES, C, 1/BW, 5%, 330	BB3315	A-B	4705-05-3300	5
R04 R13	RES, C, 1/BW, 5%, 75	BB7505	A-B	4705-05-7509	2
R05	RES, C, 1/BW, 5%, 100	BB1015	A-B	4705-05-1000	1
R06	RES, C, 1/BW, 5%, 180	BB1815	A-B	4705-05-1800	1
R14	RES, C3, 1/BW, 1%, 49.9 RF220-499	C3-49.9	CGW	4706-03-4999	1
R15	RES, C, 1/BW, 5%, 47 RC101-047	CF1/8-47	ASE	4700-05-4709	1
NONE	BIAS CKT ASSY	MA111-S3	W-I	1218-00-1100	1
NONE	I/O COUPLING NETWORK	MA111-S2	W-I	1218-00-1110	1
NONE	I/O COUPLING NETWORK	MA111-S1	W-I	1218-00-1111	1
<b>WAVETEK PARTS LIST</b>		TITLE OUTPUT AMPLIFIER MA111	ASSEMBLY NO. 111B-00-0014  PAGE: 2		REV I

REFERENCE DESIGNATORS	PART DESCRIPTION	ORIG-MFGR-PART-NO	MFGR	WAVETEK NO.	QTY
C101 C102 C103 C104 C105 C106 C107	CAP., CHIP, .1 MF	51C1209-B104Z	CFI	1510-00-3104	7
CR101	DIODE PIN	5082-3081	H-P	4805-02-0004	1
L101 L102 L103 L105 L107 L109	CHOKE, 1MH, 10% LA005-R10	0BN1R0K	ASE	1810-03-0010	6
L104 L106 L108	CHOKE, 33MH, 10% LA005-033	0BN330	ASE	1810-03-0330	3
R101 R105 R109	RES. C, 1/8W, 5%, 75	BB7505	A-B	4705-05-7509	3
R102 R106 R110	RES. C, 1/4W, 5%, 1K RC103-210	CF1/4-1K	ASE	4700-15-1001	3
R103 R107 R111	RES. C, 1/8W, 5%, 270	BB2715	A-B	4705-05-2700	3
R104 R108 R112	RES. C, 1/8W, 5%, 330	BB3315	A-B	4705-05-3300	3
<b>WAVETEK PARTS LIST</b>	TITLE I/O COUPLING NETWORK	ASSEMBLY NO. 1218-00-1111			REV
		PAGE: 1			

REFERENCE DESIGNATORS	PART DESCRIPTION	ORIG-MFGR-PART-NO	MFGR	WAVETEK NO.	QTY
CR201	DIODE PIN	5082-3081	H-P	4805-02-0004	1
CR201	DIODE PIN	5082-3081	H-P	4805-02-0004	1
L201 L202 L203 L205 L207 L209	CHOKE, 1MH, 10% LA005-R10	0BN1R0K	ASE	1810-03-0010	6
L204 L206 L208	CHOKE, 33MH, 10% LA005-033	0BN330	ASE	1810-03-0330	3
R201 R205 R209	RES. C, 1/8W, 5%, 75	BB7505	A-B	4705-05-7509	3
R202 R206 R210	RES. C, 1/4W, 5%, 1K RC103-210	CF1/4-1K	ASE	4700-15-1001	3
R203 R207 R211	RES. C, 1/8W, 5%, 270	BB2715	A-B	4705-05-2700	3
R204 R208 R212	RES. C, 1/8W, 5%, 330	BB3315	A-B	4705-05-3300	3
<b>WAVETEK PARTS LIST</b>	TITLE I/O COUPLING NETWORK	ASSEMBLY NO. 1218-00-1110			REV
		PAGE: 1			

REFERENCE DESIGNATORS	PART DESCRIPTION	ORIG-MFGR-PART-NO	MFGR	WAVETEK NO.	QTY
C301	CAP, CER, .001MFD, 1KV CD102-210	5GAD10	SPR	1510-10-1102	1
CR301	DIODE DB000-010	1N4732	ITT	4801-01-4732	1
P301	HEADER, 10-PIN STRT REF: 2112-07-0000	MC000-123	W-I	2112-07-0003	1
NONE	PC BOARD, Z413	Z413	W-I	1710-00-1100	1
NONE	HEADER, 3-PIN STRT REF: 2112-07-0000	MC000-096	W-I	2112-07-0001	6
Q301 Q303 Q305 Q307 Q309 Q311	TRANS QB000-009	MPS3702	MOT	4902-03-7020	6
Q302 Q304 Q306 Q308 Q310 Q312	TRANS QA053-060	2N5306	G-E	4901-05-3060	6
R301 R307 R313 R318	RES, C, 1/4W, 5%, 4.7K RC103-247	CF1/4-4.7K	ASE	4700-15-4701	4
R302 R304 R308 R310 R314 R316 R319 R321 R327 R332	POT, 10K	91AR10K	BEK	4610-00-7103	10
R303 R309 R315 R320	RES, C, 1/4W, 5%, 2.7K RC103-227	CF1/4-2.7K	ASE	4700-15-2701	4
R305 R311 R322 R335	RES, MF, 1/8W, 1%, 100 RF211-100	MF55K100	ASE	4701-03-1000	4
R306 R312	RES, C, 1/2W, 5%, 390 RC105-139	CF1/2-390	ASE	4700-25-3900	2
<b>WAVETEK PARTS LIST</b>		TITLE BIAS CKT ASSY	ASSEMBLY NO. 1218-00-1100  PAGE: 1		REV A

REFERENCE DESIGNATORS	PART DESCRIPTION	ORIG-MFGR-PART-NO	MFGR	WAVETEK NO.	QTY
R317 R323	RES, C, 1/2W, 5%, 220 RC105-122	CF1/2-220	ASE	4700-25-2200	2
R324 R329	RES, C, 1/4W, 5%, 3.9K RC103-239	CF1/43.9K	ASE	4700-15-3901	2
R325 R330	POT, 2K	91AR2K	BEK	4610-00-7202	2
R328 R333	RES, C, 1W, 5%, 56	QB5605	A-B	4700-35-5609	2
R334	RES, C, 1/4W, 5%, 270 RC103-127	CF1/4-270	ASE	4700-15-2700	1
<b>WAVETEK PARTS LIST</b>		TITLE BIAS CKT ASSY	ASSEMBLY NO. 1218-00-1100  PAGE: 2		REV A

REFERENCE DESIGNATORS	PART DESCRIPTION	ORIG-MFGR-PART-NO	MFGR	WAVETEK NO.	QTY
C01	CAP, CER, F. T. 1000PF CF112-210	54-794-010-102P	SPEC	1510-30-8102	1
C02	CAP, CER, 10PF, 1KV CD101-010	10TCC-010	SPR	1510-10-0100	1
C03 C06 C07 C08 C09 C10 C11 C12 C17 C18 C19	CAP, F. T., 6.8PF CF102-R68	FA5C-6892	A-B	1510-30-1689	11
C04 C14 C15	CAP, F. T., 470PF CF101-147	FA5C-4712	A-B	1510-30-0471	3
C05	CAP, MYLAR, .022MF200V CP101-322	WMF2S22	C-D	1510-60-0223	1
C13 C16	CAP, TANT, 10MF, 25V CE120-010	162D106X0025DD2	SPR	1510-21-7100	2
CR01 CR02	DIODE DG109-140	1N414B	FCD	4807-01-0914	2
IC01 IC02 IC04	DUAL OP AMP, RAYTHEON IC000-027	RC4558DN	RAY	7000-45-5801	3
IC03	IC, IC000-030	LM318N	NAT	7000-03-1800	1
L01 L02	FERRITE CHOKE LA009-010	T1255-2	HYT	1810-05-0002	2
R01	RES, MF, 1/8W, 1%, 47. 5K RF213-475	MF55K-47. 5K	ASE	4701-03-4752	1
R02	RES, MF, 1/8W, 1%, 46. 4K RF213-464	MF55K-46. 4K	ASE	4701-03-4642	1
<b>WAVETEK PARTS LIST</b>		TITLE MODULATOR, M121	ASSEMBLY NO. 1114-00-0205  PAGE: 1		REV F

REFERENCE DESIGNATORS	PART DESCRIPTION	ORIG-MFGR-PART-NO	MFGR	WAVETEK NO.	QTY
R03	RES, MF, 1/8W, 1%, 48. 7K RF213-487	MF55K-48. 7K	ASE	4701-03-4872	1
R04	RES, C, 1/4W, 5%, 150 RC103-115	CF1/4-150	ASE	4700-15-1500	1
R05	RES, C, 1/4W, 5%, 39K RC103-339	CF1/4-39K	ASE	4700-15-3902	1
R06	POT, 20K, RP131-320	360T203B	CTS	4610-00-3203	1
R07 R08 R15	RES, MF, 1/8W, 1%, 20K RF213-200	MF55K-20K	ASE	4701-03-2002	3
R09	POT, 10K, RP130-310	89PR10K	BEK	4610-00-2103	1
R10 R18 R28 R29 R35 R36	RES, MF, 1/8W, 1%, 10K RF213-100	MF55K10K	ASE	4701-03-1002	6
R11	RES, MF, 1/8W, 1%, 21. 5K RF213-215	MF55K-21. 5K	ASE	4701-03-2152	1
R12 R24	RES, MF, 1/8W, 1%, 8. 06K RF212-806	MF55K-8. 06K	ASE	4701-03-8061	2
R13	RES, C, 1/4W, 5%, 6. 8K RC103-268	CF1/4-6. 8K	ASE	4700-15-6801	1
R14 R21	RES, MF, 1/8W, 1%, 36. 5K RF213-365	MF55K-36. 5K	ASE	4701-03-3652	2
R16	RES, C, 1/4W, 5%, 33K RC103-333	CF1/4-33K	ASE	4700-15-3302	1
<b>WAVETEK PARTS LIST</b>		TITLE MODULATOR, M121	ASSEMBLY NO. 1114-00-0205  PAGE: 2		REV F

REFERENCE DESIGNATORS	PART DESCRIPTION	ORIG-MFGR-PART-NO	MFGR	WAVETEK NO.	QTY
R17	RES, MF, 1/8W, 1%, 2.74K RF212-274	MF55K-2.74K	ASE	4701-03-2741	1
R22	RES, MF, 1/8W, 1%, 12.1K RF213-121	MF55K-12.1K	ASE	4701-03-1212	1
R23	RES, MF, 1/8W, 1%, 17.8K RF213-178	MF55K-17.8K	ASE	4701-03-1782	1
R25 R38	RES, MF, 1/8W, 1%, 1.1K RF212-110	MF55K-1.1K	ASE	4701-03-1101	2
R26	RES, C, 1/4W, 5%, 10K RC103-310	CF1/4-10K	ASE	4700-15-1002	1
R27	RES, C, 1/4W, 5%, 8.2K RC103-282	CF1/4-8.2K	ASE	4700-15-8201	1
R30 R39	RES, MF, 1/8W, 1%, 100 RF211-100	MF55K100	ASE	4701-03-1000	2
R32	RES, MF, 1/8W, 1%, 100K RF214-100	MF55K-100K	ASE	4701-03-1003	1
R33	RES, MF, 1/8W, 1%, 200K RF214-200	MF55K-200K	ASE	4701-03-2003	1
R34	RES, MF, 1/8W, 1%, 42.2K RF213-422	MF55K-42.2K	ASE	4701-03-4222	1
R37	RES, C, 1/4W, 5%, 68K RC103-368	CF1/4-68K	ASE	4700-15-6802	1
<b>WAVETEK PARTS LIST</b>	TITLE MODULATOR, M121	ASSEMBLY NO. 1114-00-0205  PAGE: 3			REV F



REFERENCE DESIGNATORS	PART DESCRIPTION	ORIG-MFGR-PART-NO	MFGR	WAVETEK NO.	QTY
C01 C02 C03 C04 C05 C06 C07 C18 C19 C20 C21 C22 C23 C24	CAP, F. T., 6.8PF CF102-R68	FA5C-6892	A-B	1510-30-1689	14
C08	CAP, CER, 100PF, 1KV CD102-110	60U101M	MDC	1510-10-1101	1
C09 C11 C16 C17 C25	CAP, CER, .05MF, 100V CD103-350	TG-S50	SPR	1510-10-2503	5
C10	CAP, MDN, 1MF, 50V, 20%	3420-050-E105M	AER	1510-11-3105	1
C13 C14	CAP, CER, .01MF, 100V CD103-310	68U103M	MDC	1510-10-2103	2
C15	CAP, G-C, 2.0PF, 10% CG101-220	QC-2.0PF	G-C	1510-40-0020	1
C27 C28	CAP, CER, F. T. 1000PF CF112-210	54-794-010-102P	SPEC	1510-30-8102	2
CR01 CR02 CR03 CR04 CR05 CR06 CR07 CR08 CR09 CR10 CR11 CR12 CR13 CR14 CR15 CR16 CR17 CR18 CR19 CR20 CR21 CR22 CR23 CR24 CR25 CR26 CR27 CR28 CR29 CR30 CR31 CR32 CR33 CR34 CR35 CR36 CR37 CR38 CR39 CR40 CR41 CR42 CR43 CR44 CR45 CR46 CR47 CR48 CR49	DIODE DG109-140	1N4148	FCD	4807-01-0914	49
<b>WAVETEK PARTS LIST</b>	TITLE BAND SELECT, M131	ASSEMBLY NO. 1114-00-0252  PAGE: 1	REV C		

REFERENCE DESIGNATORS	PART DESCRIPTION	ORIG-MFGR-PART-NO	MFGR	WAVETEK NO.	QTY
IC01 IC02 IC03 IC04	DUAL OP AMP, RAYTHEON IC000-027	RC4558DN	RAY	7000-45-5801	4
Q01 Q02 Q04	TRANS QA054-580	2N5458	MDT	4901-05-4580	3
Q03 Q05	TRANS QA054-610	2N5461	MDT	4901-05-4610	2
Q06 Q08 Q10 Q11 Q12 Q13	TRANS QB000-009	MPS3702	MDT	4902-03-7020	6
Q07 Q09	TRANS QA038-541	2N3854A	G-E	4901-03-8541	2
Q14 Q15 Q16 Q17	TRANS QA039-040	2N3904	T-I	4901-03-9040	4
R01 R02 R03	RES, SET, 3-178K, 1/8W QTY: 3: 4701-03-1783	RX000-002	W-I	4789-00-0001	1
R04 R05 R06 R07	RES, SET, 464K-MTCH. 1% QTY: 4: 4701-03-4643	4789-00-0008	W-I	4789-00-0008	1
R08 R10 R21 R24	RES, C, 1/4W, 5%, 10M RC103-610	CB1065	A-B	4700-15-1005	4
R11 R19 R9	RES, C, 1/4W, 5%, 47M RC103-647	CB4765	A-B	4700-15-4705	3
R12	RES, C, 1/4W, 5%, 200K RC103-420	CF1/4-200K	ASE	4700-15-2003	1
R13 R38	RES, SET, 2-178K, 1/8W QTY: 2: 4701-03-1783	RX000-005	W-I	4789-00-0002	1
<b>WAVETEK PARTS LIST</b>	TITLE BAND SELECT, M131	ASSEMBLY NO. 1114-00-0252  PAGE: 2	REV C		

REFERENCE DESIGNATORS	PART DESCRIPTION	ORIG-MFGR-PART-NO	MFGR	WAVETEK NO.	QTY
R14 R15 R20 R32 R73 R98	RES, C, 1/4W, 5%, 1M RC103-510	CF1/4-1M	ASE	4700-15-1004	6
R16	RES, MF, 1/8W, 1%, 40.2K RF213-402	MF55K-40.2K	ASE	4701-03-4022	1
R17 R45	PDT, 1M RP101-510	U201	CTS	4610-10-0105	2
R18 R34 R36 R40 R42 R44 R63	PDT, 100K, RP144-410	91WR100K	BEK	4610-00-4104	7
R22	RES, MF, 1/8W, 1%, 34.0K RF213-340	MF55K-34.0K	ASE	4701-03-3402	1
R23	RES, MF, 1/8W, 1%, 3.48K RF212-348	MF55K-3.48K	ASE	4701-03-3481	1
R25	RES, MF, 1/8W, 1%, 1.1K RF212-110	MF55K-1.1K	ASE	4701-03-1101	1
R26	RES, MF, 1/8W, 1%, 4.99K RF212-499	MF55K-4.99K	ASE	4701-03-4991	1
R27	RES, MF, 1/8W, 1%, 1K RF212-100	MF55K-1K	ASE	4701-03-1001	1
R28	RES, MF, 1/8W, 1%, 76.8K RF213-768	MF55K-76.8K	ASE	4701-03-7682	1
R29	RES, C, 1/4W, 5%, 680K RC103-468	CF1/4-680K	ASE	4700-15-6803	1
<b>WAVETEK PARTS LIST</b>		TITLE BAND SELECT, M131	ASSEMBLY NO. 1114-00-0252		REV C
			PAGE: 3		

REFERENCE DESIGNATORS	PART DESCRIPTION	ORIG-MFGR-PART-NO	MFGR	WAVETEK NO.	QTY
R30	RES, MF, 1/8W, 1%, 21.5K RF213-215	MF55K-21.5K	ASE	4701-03-2152	1
R31	RES, MF, 1/8W, 1%, 9.09K RF212-909	MF55K-9.09K	ASE	4701-03-9091	1
R33	RES, MF, 1/8W, 1%, 16.5K RF213-165	MF55K-16.5K	ASE	4701-03-1652	1
R35	RES, C, 1/4W, 5%, 360K RC103-436	CF1/4-360K	ASE	4700-15-3603	1
R37	RES, C, 1/4W, 5%, 620K RC103-462	CB6245	A-B	4700-15-6203	1
R39	RES, C, 1/4W, 5%, 180K RC103-418	CF1/4-180K	ASE	4700-15-1803	1
R41 R74	RES, C, 1/4W, 5%, 270K RC103-427	CF1/4-270K	ASE	4700-15-2703	2
R43	RES, C, 1/4W, 5%, 390K RC103-439	CF1/4-390K	ASE	4700-15-3903	1
R46 R58 R68	RES, C, 1/4W, 5%, 100K RC103-410	CF1/4-100K	ASE	4700-15-1003	3
R47 R50 R61 R64 R70 R71 R79 R80 R81 R83 R96 R97	RES, C, 1/4W, 5%, 10K RC103-310	CF1/4-10K	ASE	4700-15-1002	12
R48	RES, C, 1/4W, 5%, 3.3K RC103-233	CF1/4-3.3K	ASE	4700-15-3301	1
<b>WAVETEK PARTS LIST</b>		TITLE BAND SELECT, M131	ASSEMBLY NO. 1114-00-0252		REV C
			PAGE: 4		

REFERENCE DESIGNATORS	PART DESCRIPTION	ORIG-MFGR-PART-NO	MFGR	WAVETEK NO.	QTY	
R49 R51	RES, C, 1/4W, 5%, 51K RC103-351	CF1/4-51K	ASE	4700-15-5102	2	
R52 R55	RES, C, 1/4W, 5%, 82K RC103-382	CF1/4-82K	ASE	4700-15-8202	2	
R53 R54 R66 R69	RES, C, 1/4W, 5%, 15K RC103-315	CF1/4-15K	ASE	4700-15-1502	4	
R56 R62 R67 R82	RES, C, 1/4W, 5%, 27K RC103-327	CF1/4-27K	ASE	4700-15-2702	4	
R57 R60	POT, 10K, RP144-310	91WR10K	BEK	4610-00-4103	2	
R59 R75	RES, C, 1/4W, 5%, 4.7K RC103-247	CF1/4-4.7K	ASE	4700-15-4701	2	
R72	RES, C, 1/4W, 5%, 2.2M RC103-522	CF1/4-2.2M	ASE	4700-15-2204	1	
R76 R77 R78	RES, C, 1/4W, 5%, 33K RC103-333	CF1/4-33K	ASE	4700-15-3302	3	
R84 R85 R86 R87	RES, C, 1/4W, 5%, 1.8K RC103-218	CF1/4-1.8K	ASE	4700-15-1801	4	
R88 R89 R90 R91	RES, C, 1/4W, 5%, 22K RC103-322	CF1/422K	ASE	4700-15-2202	4	
R92 R93 R94 R95 R99	RES, C, 1/4W, 5%, 47K RC103-347	CF1/4-47K	ASE	4700-15-4702	5	
		TITLE BAND SELECT, M131		ASSEMBLY NO. 1114-00-0252  PAGE: 5		REV C

REFERENCE DESIGNATORS	PART DESCRIPTION	ORIG-MFGR-PART-NO	MFGR	WAVETEK NO.	QTY
C01 C02 C03 C04 C05 C06 C09 C10 C11 C12 C13 C14 C15 C16	CAP, F. T., 6.8PF CF102-R68	FA5C-6892	A-B	1510-30-1689	14
C07 C08	CAP, F. T., 470PF CF101-147	FA5C-4712	A-B	1510-30-0471	2
C17 C18	CAP, TANT, 10MF, 25V CE120-010	162D106X0025DD2	SPR	1510-21-7100	2
CR01 CR02 CR03 CR04 CR05 CR06	DIODE DG109-140	1N4148	FCD	4807-01-0914	6
Q01 Q03 Q05 Q08 Q10 Q11 Q12 Q13	TRANS GA03B-541	2N3854A	G-E	4901-03-8541	8
Q02 Q04 Q06 Q07 Q09	TRANS GB000-009	MPS3702	MOT	4902-03-7020	5
R01 R05 R09	RES, C, 1/4W, 5%, 82K RC103-382	CF1/4-82K	ASE	4700-15-8202	3
R02 R04 R06 R08 R10 R12	RES, C, 1/4W, 5%, 15K RC103-315	CF1/4-15K	ASE	4700-15-1502	6
R03 R07 R11	RES, C, 1/4W, 5%, 51K RC103-351	CF1/4-51K	ASE	4700-15-5102	3
R13 R17	RES, C, 1/4W, 5%, 100K RC103-410	CF1/4-100K	ASE	4700-15-1003	2
R14 R27	RES, C, 1/4W, 5%, 22K RC103-322	CF1/422K	ASE	4700-15-2202	2
<b>WAVETEK PARTS LIST</b>	TITLE INTERFACE, M132	ASSEMBLY NO. 1114-00-0251 PAGE: 1	REV A		

REFERENCE DESIGNATORS	PART DESCRIPTION	ORIG-MFGR-PART-NO	MFGR	WAVETEK NO.	QTY
R15 R16 R19 R22	RES, C, 1/4W, 5%, 47K RC103-347	CF1/4-47K	ASE	4700-15-4702	4
R18 R21 R23 R24 R26 R29	RES, C, 1/4W, 5%, 10K RC103-310	CF1/4-10K	ASE	4700-15-1002	6
R20 R25	RES, C, 1/4W, 5%, 1.5K RC103-215	CF1/4-1.5K	ASE	4700-15-1501	2
<b>WAVETEK PARTS LIST</b>	TITLE INTERFACE, M132	ASSEMBLY NO. 1114-00-0251 PAGE: 2	REV A		

REFERENCE DESIGNATORS	PART DESCRIPTION	ORIG-MFGR-PART-NO	MFGR	WAVETEK NO.	QTY
C1	CAP, F. T., 470PF CF101-147	FA5C-4712	A-B	1510-30-0471	1
C2	CAP, FT, 500PF, 20%250V CF104-150	4420-500PF	AER	1510-30-3501	1
C3	CAP, CER., .01MF, 100V CD103-310	68U103M	MDC	1510-10-2103	1
C4	CAP, CER., .05MF, 100V CD103-350	TG-S50	SPR	1510-10-2503	1
C5	CAP, F. T., 6.8PF CF102-R68	FA5C-6892	A-B	1510-30-1689	1
CR1	DIODE DG100-821	1N82AG	G-I	4807-01-0082	1
J1 J2 J3	CONN JF000-005	37JR116-1	S-C	2110-03-0002	3
L01	TORRID, 4 TURN	LA009-004-1	HYT	1810-05-0003	1
G1	TRANS GA03B-541	2N3854A	G-E	4901-03-8541	1
R01	RES, C, 1/4W, 5%, 47 RC103-047	CF1/4-47	ASE	4700-15-4709	1
R02	RES, C, 1/4W, 5%, 51 RC103-051	CF1/451	ASE	4700-15-5109	1
R03 R05	RES, C, 1/4W, 5%, 470 RC103-147	CF1/4-470	ASE	4700-15-4700	2
R04	RES, C, 1/4W, 5%, 150 RC103-115	CF1/4-150	ASE	4700-15-1500	1
<b>WAVETEK PARTS LIST</b>		TITLE EXT MKR, M&C	ASSEMBLY NO. 1114-00-0124  PAGE: 1		REV B

REFERENCE DESIGNATORS	PART DESCRIPTION	ORIG-MFGR-PART-NO	MFGR	WAVETEK NO.	QTY
R06	RES, C, 1/4W, 5%, 180K RC103-418	CF1/4-180K	ASE	4700-15-1803	1
R07	RES, C, 1/4W, 5%, 470K RC103-447	CF1/4-470K	ASE	4700-15-4703	1
R08 R10	RES, C, 1/4W, 5%, 10K RC103-310	CF1/4-10K	ASE	4700-15-1002	2
R09	POT, 20K RP124-320	WA29032S-203MA	A-B	4610-10-7203	1
<b>WAVETEK PARTS LIST</b>		TITLE EXT MKR, M&C	ASSEMBLY NO. 1114-00-0124  PAGE: 2		REV B

REFERENCE DESIGNATORS	PART DESCRIPTION	ORIG-MFGR-PART-NO	MFGR	WAVETEK NO.	QTY
C01	CAP, VALUE DETERMINED IN CALIBRATION	CAP, TRIM	W-I	1519-99-9999	1
C02	CAP, CER, 33PF, 1KV CD104-033	10TU-Q33	SPR	1510-10-3330	1
C03 C14	CAP, CER, .01MF, 100V CD103-310	68U103M	MDC	1510-10-2103	2
C04	CAP, CER, .025MF, 50V CD103-325	TG-S25	SPR	1510-10-2253	1
C05	CAP, CER, 68PF, 1KV CD104-068	68U2J680J	MDC	1510-10-3680	1
C06	CAP, CER, 100PF, 1KV CD104-110	10TCU-T10	SPR	1510-10-3101	1
C07	CAP, VAR, 3.5-13PF250V CV101-013	7S-TRIKD-02-3.5-13PF	STR	1510-70-0130	1
C08	CAP, CER, 15PF, 1KV CD101-015	10TCC-Q15	SPR	1510-10-0150	1
C09	CAP, CER, 47PF, 1KV CD104-047	60U2J470J	MDC	1510-10-3470	1
C10 C13	CAP, CER, .001MFD, 1KV CD102-210	56AD10	SPR	1510-10-1102	2
C11	CAP, TANT, .47MF, 50V CE113-447	935	TRW	1510-21-9470	1
<b>WAVETEK PARTS LIST</b>		TITLE HAR MKR, M6H-1	ASSEMBLY NO. 1114-00-0050  PAGE: 1		REV F

REFERENCE DESIGNATORS	PART DESCRIPTION	ORIG-MFGR-PART-NO	MFGR	WAVETEK NO.	QTY
C12	CAP, CER, 470PF, 1KV CD102-147	60U471M	MDC	1510-10-1471	1
C15	CAP, FT, 500PF, 20%250V CF104-150	4420-500PF	AER	1510-30-3501	1
C16	CAP, F. T., .6.8PF CF102-R68	FA5C-6892	A-B	1510-30-1689	1
C17	CAP, F. T., 470PF CF101-147	FA5C-4712	A-B	1510-30-0471	1
C18	CAP, TANT, 10MF, 25V CE120-010	162D106X0025DD2	SPR	1510-21-7100	1
CR1 CR2	DIODE DG100-821	1N82AG	G-I	4807-01-0082	2
J1 J2	CONN JF000-005	37JR116-1	S-C	2110-03-0002	2
L1 L2 L3	RF CHOKE	CHOKE	W-I	1819-99-9999	3
L04	TORRID, 4 TURN	LA009-004-1	HYT	1810-05-0003	1
Q1 Q3	TRANS QB000-009	MPS3702	MOT	4902-03-7020	2
Q2	TRANS QA038-541	2N3854A	G-E	4901-03-8541	1
Q4	TRANS QA051-790	2N5179	RCA	4901-05-1790	1
Q5	TRANS QB000-013	A430	APX	4902-00-4300	1
Q6	TRANS QA054-580	2N5458	MOT	4901-05-4580	1
<b>WAVETEK PARTS LIST</b>		TITLE HAR MKR, M6H-1	ASSEMBLY NO. 1114-00-0050  PAGE: 2		REV F

REFERENCE DESIGNATORS	PART DESCRIPTION	ORIG-MFGR-PART-NO	MFGR	WAVETEK NO.	QTY
Q7	TRANS QA050-880	2N5088	MOT	4901-05-0880	1
R01 R16	RES. C, 1/4W, 5%, 1K RC103-210	CF1/4-1K	ASE	4700-15-1001	2
R02 R05 R12	RES. C, 1/4W, 5%, 3.9K RC103-239	CF1/43.9K	ASE	4700-15-3901	3
R03 R04	RES. C, 1/4W, 5%, 2.2K RC103-222	CF1/4-2.2K	ASE	4700-15-2201	2
R06	RES. C, 1/4W, 5%, 27K RC103-327	CF1/4-27K	ASE	4700-15-2702	1
R07 R09 R13	RES. C, 1/4W, 5%, 470 RC103-147	CF1/4-470	ASE	4700-15-4700	3
R08 R20	RES. C, 1/4W, 5%, 10K RC103-310	CF1/4-10K	ASE	4700-15-1002	2
R10 R24	RES. C, 1/4W, 5%, 100 RC103-110	CF1/4-100	ASE	4700-15-1000	2
R11	RES. C, 1/4W, 5%, 75 RC103-075	CR1/4-75	ASE	4700-15-7509	1
R14	RES. C, 1/4W, 5%, 33K RC103-333	CF1/4-33K	ASE	4700-15-3302	1
R15	RES. C, 1/4W, 5%, 1M RC103-510	CF1/4-1M	ASE	4700-15-1004	1
R17	RES. C, 1/4W, 5%, 8.2K RC103-282	CF1/4-8.2K	ASE	4700-15-8201	1
<b>WAVETEK PARTS LIST</b>		TITLE HAR MKR, M6H-1	ASSEMBLY NO. 1114-00-0050  PAGE: 3		REV F

REFERENCE DESIGNATORS	PART DESCRIPTION	ORIG-MFGR-PART-NO	MFGR	WAVETEK NO.	QTY
R18	RES. C, 1/4W, 5%, 15K RC103-315	CF1/4-15K	ASE	4700-15-1502	1
R19	RES. C, 1/4W, 5%, 1.5M RC103-515	CF1/4-1.5M	ASE	4700-15-1504	1
R21	PDT, 20K RP124-320	WA20032S-203MA	A-B	4610-10-7203	1
R22 R23	RES. C, 1/4W, 5%, 4.7K RC103-247	CF1/4-4.7K	ASE	4700-15-4701	2
X1	CRYSTAL X25W XX000-251	X25W-00.00000	W-I	2310-00-0251	1
<b>WAVETEK PARTS LIST</b>		TITLE HAR MKR, M6H-1	ASSEMBLY NO. 1114-00-0050  PAGE: 4		REV F

REFERENCE DESIGNATORS	PART DESCRIPTION	ORIG-MFGR-PART-NO	MFGR	WAVETEK NO.	QTY
C01 C07	CAP, CER, 47PF, 1KV CD104-047	60U2J470J	MDC	1510-10-3470	2
C02	CAP, CER, 330PF, 1KV CD104-133	10TCU-T33	SPR	1510-10-3331	1
C03	CAP, CER, 120PF, 1KV CD104-112	10TCU-T12	SPR	1510-10-3121	1
C04	CAP, FT, 500PF, 20%250V CF104-150	4420-500PF	AER	1510-30-3501	1
C05	CAP, VAR, 3.5-13PF250V CV101-013	7S-TRIKO-02-3.5-13PF	STR	1510-70-0130	1
C06	CAP, CER, 15PF, 1KV CD101-015	10TCC-Q15	SPR	1510-10-0150	1
C08 C09	CAP, CER, .001MFD, 1KV CD102-210	5GAD10	SPR	1510-10-1102	2
C10	CAP, CER, .01MF, 100V CD103-310	68U103M	MDC	1510-10-2103	1
C11	CAP, F. T., 6.8PF CF102-R68	FA5C-6892	A-B	1510-30-1689	1
C12	CAP, F. T., 470PF CF101-147	FA5C-4712	A-B	1510-30-0471	1
C13	CAP, TANT, 10MF, 25V CE120-010	162D106X0025DD2	SPR	1510-21-7100	1
<b>WAVETEK PARTS LIST</b>		TITLE HAR MKR, M6H-10	ASSEMBLY NO. 1114-00-0099		REV D
			PAGE: 1		

REFERENCE DESIGNATORS	PART DESCRIPTION	ORIG-MFGR-PART-NO	MFGR	WAVETEK NO.	QTY
CR1	DIODE DG100-821	1N82AG	G-I	4807-01-0082	1
J1 J2	CONN JF000-005	37JR116-1	S-C	2110-03-0002	2
L1 L3	RF CHOKE	CHOKE	W-I	1819-99-9999	2
L02	TORRID, 10 TURN	LA009-010-1	HYT	1810-05-0004	1
L04	TORRID, 4 TURN	LA009-004-1	HYT	1810-05-0003	1
Q1	TRANS QA038-541	2N3854A	G-E	4901-03-8541	1
Q2	TRANS QB000-013	A430	APX	4902-00-4300	1
Q3	TRANS QA054-580	2N5458	MOT	4901-05-4580	1
Q4	TRANS QA050-880	2N5088	MOT	4901-05-0880	1
R01	RES, C, 1/4W, 5%, 47K RC103-347	CF1/4-47K	ASE	4700-15-4702	1
R02	RES, C, 1/4W, 5%, 56 RC103-056	CF1/4-56	ASE	4700-15-5609	1
R03	RES, C, 1/4W, 5%, 1.5K RC103-215	CF1/4-1.5K	ASE	4700-15-1501	1
R04 R17	RES, C, 1/4W, 5%, 100 RC103-110	CF1/4-100	ASE	4700-15-1000	2
R05	RES, C, 1/4W, 5%, 75 RC103-075	CR1/4-75	ASE	4700-15-7509	1
<b>WAVETEK PARTS LIST</b>		TITLE HAR MKR, M6H-10	ASSEMBLY NO. 1114-00-0099		REV D
			PAGE: 2		



REFERENCE DESIGNATORS	PART DESCRIPTION	ORIG-MFGR-PART-NO	MFGR	WAVETEK NO.	QTY
R06	RES. C, 1/4W, 5%, 3.9K RC103-239	CF1/43.9K	ASE	4700-15-3901	1
R07	RES. C, 1/4W, 5%, 470 RC103-147	CF1/4-470	ASE	4700-15-4700	1
R08	RES. C, 1/4W, 5%, 33K RC103-333	CF1/4-33K	ASE	4700-15-3302	1
R09	RES. C, 1/4W, 5%, 1M RC103-510	CF1/4-1M	ASE	4700-15-1004	1
R10	RES. C, 1/4W, 5%, 1K RC103-210	CF1/4-1K	ASE	4700-15-1001	1
R11	RES. C, 1/4W, 5%, 8.2K RC103-282	CF1/4-8.2K	ASE	4700-15-8201	1
R12	RES. C, 1/4W, 5%, 15K RC103-315	CF1/4-15K	ASE	4700-15-1502	1
R13	RES. C, 1/4W, 5%, 1.5M RC103-515	CF1/4-1.5M	ASE	4700-15-1504	1
R14	RES. C, 1/4W, 5%, 10K RC103-310	CF1/4-10K	ASE	4700-15-1002	1
R15	POT. 20K RP124-320	WA2G032S-203MA	A-B	4610-10-7203	1
R16	RES. C, 1/4W, 5%, 100K RC103-410	CF1/4-100K	ASE	4700-15-1003	1
X1	CRYSTAL, XX000-321	X32W-00.00000	W-I	2310-00-0321	1
<b>WAVETEK PARTS LIST</b>		TITLE HAR MKR. M6H-10	ASSEMBLY NO. 1114-00-0099  PAGE: 3		REV D

REFERENCE DESIGNATORS	PART DESCRIPTION	ORIG-MFGR-PART-NO	MFGR	WAVETEK NO.	QTY
C01	CAP, CER, 20PF, 1KV CD101-020	60C06200J	MDC	1510-10-0200	1
C02	CAP, CER, 120PF, 1KV CD104-112	10TCU-T12	SPR	1510-10-3121	1
C03 C07	CAP, CER, 47PF, 1KV CD104-047	60U2J470J	MDC	1510-10-3470	2
C04	CAP, FT, 500PF, 20%250V CF104-150	4420-500PF	AER	1510-30-3501	1
C05	CAP, VAR, 3.5-13PF250V CV101-013	75-TRIKO-02-3.5-13PF	STR	1510-70-0130	1
C06	CAP, CER, 15PF, 1KV CD101-015	10TCC-Q15	SPR	1510-10-0150	1
C08 C09	CAP, CER, .001MFD, 1KV CD102-210	5GAD10	SPR	1510-10-1102	2
C10	CAP, CER, .01MF, 100V CD103-310	68U103M	MDC	1510-10-2103	1
C11	CAP, F. T., 6.8PF CF102-R68	FA5C-6892	A-B	1510-30-1689	1
C12	CAP, F. T., 470PF CF101-147	FA5C-4712	A-B	1510-30-0471	1
C13	CAP, TANT, 10MF, 25V CE120-010	162D106X0025DD2	SPR	1510-21-7100	1
<b>WAVETEK PARTS LIST</b>		TITLE HAR MKR, M6H-50	ASSEMBLY NO. 1114-00-0100		REV E
			PAGE: 1		

REFERENCE DESIGNATORS	PART DESCRIPTION	ORIG-MFGR-PART-NO	MFGR	WAVETEK NO.	QTY
CR1	DIODE DG100-821	1N82AG	G-I	4807-01-0082	1
J1 J2	CONN JF000-005	37JR116-1	S-C	2110-03-0002	2
L1 L3	RF CHOKE	CHOKE	W-I	1819-99-9999	2
L02	TORRID, 10 TURN	LA009-010-1	HYT	1810-05-0004	1
L04	TORRID, 4 TURN	LA009-004-1	HYT	1810-05-0003	1
Q01	TRANS QA039-040	2N3904	T-I	4901-03-9040	1
Q2	TRANS QB000-013	A430	APX	4902-00-4300	1
Q3	TRANS QA054-580	2N5458	MOT	4901-05-4580	1
Q4	TRANS QA050-880	2N5088	MOT	4901-05-0880	1
R01	RES, C, 1/4W, 5%, 47K RC103-347	CF1/4-47K	ASE	4700-15-4702	1
R02	RES, C, 1/4W, 5%, 56 RC103-056	CF1/4-56	ASE	4700-15-5609	1
R03	RES, C, 1/4W, 5%, 1.5K RC103-215	CF1/4-1.5K	ASE	4700-15-1501	1
R04 R17	RES, C, 1/4W, 5%, 100 RC103-110	CF1/4-100	ASE	4700-15-1000	2
R05	RES, C, 1/4W, 5%, 75 RC103-075	CR1/4-75	ASE	4700-15-7509	1
<b>WAVETEK PARTS LIST</b>		TITLE HAR MKR, M6H-50	ASSEMBLY NO. 1114-00-0100		REV E
			PAGE: 2		

REFERENCE DESIGNATORS	PART DESCRIPTION	ORIG-MFGR-PART-NO	MFGR	WAVETEK NO.	QTY
R06	RES, C, 1/4W, 5%, 3.9K RC103-239	CF1/43.9K	ASE	4700-15-3901	1
R07	RES, C, 1/4W, 5%, 470 RC103-147	CF1/4-470	ASE	4700-15-4700	1
R08	RES, C, 1/4W, 5%, 33K RC103-333	CF1/4-33K	ASE	4700-15-3302	1
R09	RES, C, 1/4W, 5%, 1M RC103-510	CF1/4-1M	ASE	4700-15-1004	1
R10	RES, C, 1/4W, 5%, 1K RC103-210	CF1/4-1K	ASE	4700-15-1001	1
R11	RES, C, 1/4W, 5%, 8.2K RC103-282	CF1/4-8.2K	ASE	4700-15-8201	1
R12	RES, C, 1/4W, 5%, 15K RC103-315	CF1/4-15K	ASE	4700-15-1502	1
R13	RES, C, 1/4W, 5%, 1.5M RC103-515	CF1/4-1.5M	ASE	4700-15-1504	1
R14	RES, C, 1/4W, 5%, 10K RC103-310	CF1/4-10K	ASE	4700-15-1002	1
R15	POT, 20K RP124-320	WA20032S-203MA	A-B	4610-10-7203	1
R16	RES, C, 1/4W, 5%, 100K RC103-410	CF1/4-100K	ASE	4700-15-1003	1
X1	CRYSTAL, XX000-331	X33W-00.00000	W-I	2310-00-0331	1
<b>WAVETEK PARTS LIST</b>		TITLE HAR MKR, M6H-50	ASSEMBLY NO. 1114-00-0100  PAGE: 3		REV E

REFERENCE DESIGNATORS	PART DESCRIPTION	ORIG-MFGR-PART-NO	MFGR	WAVETEK NO.	QTY
C02	CAP, CER, 20PF, 1KV CD101-020	60C0G200J	MDC	1510-10-0200	1
C02	CAP, CER, 20PF, 1KV CD101-020	60C0G200J	MDC	1510-10-0200	1
C03	CAP, CER, 120PF, 1KV CD104-112	10TCU-T12	SPR	1510-10-3121	1
C04 C09	CAP, FT, 500PF, 20%250V CF104-150	4420-500PF	AER	1510-30-3501	2
C05	CAP, F. T., 470PF CF101-147	FA5C-4712	A-B	1510-30-0471	1
C08	CAP, VALUE DETERMINED IN CALIBRATION	CAP, TRIM	W-I	1519-99-9999	1
C10	CAP, CER, .01MF, 100V CD103-310	68U103M	MDC	1510-10-2103	1
C11	CAP, CER, .05MF, 100V CD103-350	TG-S50	SPR	1510-10-2503	1
C12	CAP, F. T., 6.8PF CF102-R68	FA5C-6892	A-B	1510-30-1689	1
CR1A	DIODE DG000-007	5082-2800	H-P	4809-02-0001	1
CR2	DIODE DG100-821	1N82A9	G-I	4807-01-0082	1
J1 J2	CONN JF000-005	37JR116-1	S-C	2110-03-0002	2
<b>WAVETEK PARTS LIST</b>		TITLE S. F. MKR, M6S-3	ASSEMBLY NO. 1114-00-0045  PAGE: 1		REV A

REFERENCE DESIGNATORS	PART DESCRIPTION	ORIG-MFGR-PART-NO	MFGR	WAVETEK NO.	QTY
L2	CHOKE, 2.2MH, 10% LA005-R22	08N2R2K	ASE	1810-03-0229	1
Q1 Q2	TRANS QA038-541	2N3854A	G-E	4901-03-8541	2
R1	RES, C, 1/4W, 5%, 47K RC103-347	CF1/4-47K	ASE	4700-15-4702	1
R2	RES, C, 1/4W, 5%, 56 RC103-056	CF1/4-56	ASE	4700-15-5609	1
R3 R4	RES, C, 1/4W, 5%, 1.5K RC103-215	CF1/4-1.5K	ASE	4700-15-1501	2
R5	RES, C, 1/4W, 5%, 180K RC103-418	CF1/4-180K	ASE	4700-15-1803	1
R6	RES, C, 1/4W, 5%, 470K RC103-447	CF1/4-470K	ASE	4700-15-4703	1
R7 R9	RES, C, 1/4W, 5%, 10K RC103-310	CF1/4-10K	ASE	4700-15-1002	2
RB	PDT, 20K RP124-320	WA29032S-203MA	A-B	4610-10-7203	1
X1	CRYSTAL, XX000-331	X33W-00.00000	W-I	2310-00-0331	1
<b>WAVETEK PARTS LIST</b>		TITLE S. F. MKR, M6S-3	ASSEMBLY NO. 1114-00-0045  PAGE: 2		REV A

REFERENCE DESIGNATORS	PART DESCRIPTION	ORIG-MFGR-PART-NO	MFGR	WAVETEK NO.	QTY
C05 C06	CAP, TANT, 10MF, 25V CE120-010	162D106X0025DD2	SPR	1510-21-7100	2
C05 C06	CAP, TANT, 10MF, 25V CE120-010	162D106X0025DD2	SPR	1510-21-7100	2
C07 C22	CAP, CER, .01MF, 100V CD103-310	68U103M	MDC	1510-10-2103	2
C08	CAP, CER, .01MF, 50V CD113-310	CY15C103M	C-L	1510-10-8103	1
C09	CAP, CER, 47PF, 1KV CD104-047	60U2J470J	MDC	1510-10-3470	1
C10	CAP, CER, 15PF, 1KV CD101-015	10TCC-Q15	SPR	1510-10-0150	1
C11 C14 C17 C18 C26	CAP, VAR, 3.5-13PF250V CV101-013	7S-TRIKO-02-3.5-13PF	STR	1510-70-0130	5
C12	CAP, CER, 120PF, 1KV CD104-112	10TCU-T12	SPR	1510-10-3121	1
C13 C24	CAP, FT, 500PF, 20%250V CF104-150	4420-500PF	AER	1510-30-3501	2
C15	CAP, M. C., .3.9PF CG102-239	MC-3.9PF	Q-C	1510-40-1399	1
C16 C19	CAP, M. C., .47PF CG102-147	MC-.47PF	Q-C	1510-40-1478	2
<b>WAVETEK PARTS LIST</b>		TITLE DLX HAR MKR, M106	ASSEMBLY NO. 1114-00-0152  PAGE: 1		REV B

REFERENCE DESIGNATORS	PART DESCRIPTION	ORIG-MFGR-PART-NO	MFGR	WAVETEK NO.	QTY
C20	CAP, Q. C., 1.1PF CG101-211	QC-1.1PF	Q-C	1510-40-0119	1
C21	CAP, ELECT, 1MF, 25V CE120-001	162D105X9025BC2	SPR	1510-21-7010	1
C23	CAP, CER, DISC, .001MF 50V, CD112-210	8101-050-102M	ETP	1510-10-7102	1
C25	CAP, CER, 270PF, 1KV CD102-127	60U271M	MDC	1510-10-1271	1
C27	CAP, CER, F. T., 68PF CF120-068	4420-68PF	AVX	1510-31-6680	1
C28	CAP, Q-C, 2.0PF, 10% CG101-220	QC-2.0PF	Q-C	1510-40-0020	1
C29 C30 C31	CAP, VARI, 7.35PF, 250V CV101-035	7STRIKO-02	STR	1510-70-0350	3
C34 C36	CAP, CER, .05MF, 100V CD103-350	TG-S50	SPR	1510-10-2503	2
C35 C37	CAP, F. T., 6.8PF CF102-R68	FA5C-6892	A-B	1510-30-1689	2
C41	CAP, M. C., .22PF CG102-122	MC-.22PF	Q-C	1510-40-1228	1
C42	CAP, M-C, 4.7PF, 10% CG102-247	QC-4.7PF	Q-C	1510-40-1479	1
<b>WAVETEK PARTS LIST</b>		TITLE DLX HAR MKR, M106	ASSEMBLY NO. 1114-00-0152  PAGE: 2		REV B

REFERENCE DESIGNATORS	PART DESCRIPTION	ORIG-MFGR-PART-NO	MFGR	WAVETEK NO.	QTY
C43	CAP, VAR, 2.5/5PF	5S-TRIKO-04-2.5/5	STR	1510-70-8509	1
CR01 CRO2	DIODE D6000-007	5082-2800	H-P	4809-02-0001	2
CR03	DIODE D6000-012	5082-0180	H-P	4811-02-0001	1
CR4	DIODE D6100-821	1N82A6	G-I	4807-01-0082	1
IC01	IC, IC000-011	78M05UC	FCD	7000-78-0500	1
J01 J02	CONN JF000-005	37JR116-1	S-C	2110-03-0002	2
L01 L12 L13 L14 L15	CHOKE .47MH 10% LA005-R04	08NR47K	ASE	1810-03-0478	5
L02 L03 L05 L06 L09	CHOKE .22MH 10% LA005-R02	08NR22K	ASE	1810-03-0228	5
L04 L07	CHOKE, 1MH, 10% LA005-R10	08N1R0K	ASE	1810-03-0010	2
L08	CHOKE, 3.3MH, 10% LA005-R33	08N3R3K	ASE	1810-03-0339	1
L10	RF CHOKE	CHOKE	W-I	1819-99-9999	1
L16	CHOKE, .82MH 10%	080R82K	ASE	1810-03-0828	1
Q1 Q3 Q4 Q5 Q6	TRANS GA050-530	2N5053	APX	4901-05-0530	5
Q2	TRANS GA038-541	2N3854A	G-E	4901-03-8541	1
R01	RES, C, 1/4W, 5%, 1.8K RC103-218	CF1/4-1.8K	ASE	4700-15-1801	1
<b>WAVETEK PARTS LIST</b>		TITLE DLX HAR MKR, M106	ASSEMBLY NO. 1114-00-0152		REV B
			PAGE: 3		

REFERENCE DESIGNATORS	PART DESCRIPTION	ORIG-MFGR-PART-NO	MFGR	WAVETEK NO.	QTY
R02 R03 R12 R15	RES, C, 1/4W, 5%, 1K RC103-210	CF1/4-1K	ASE	4700-15-1001	4
R04 R09 R10	RES, C, 1/4W, 5%, 100 RC103-110	CF1/4-100	ASE	4700-15-1000	3
R05	RES, C, 1/4W, 5%, 18K RC103-318	CF1/4-18K	ASE	4700-15-1802	1
R06 R25 R26	RES, C, 1/4W, 5%, 10K RC103-310	CF1/4-10K	ASE	4700-15-1002	3
R07	RES, C, 1/4W, 5%, 47K RC103-347	CF1/4-47K	ASE	4700-15-4702	1
R08	RES, C, 1/4W, 5%, 1.2K RC103-212	CF1/4-1.2K	ASE	4700-15-1201	1
R11 R14 R17	RES, C, 1/4W, 5%, 470 RC103-147	CF1/4-470	ASE	4700-15-4700	3
R13 R20 R36	RES, C, 1/4W, 5%, 82 RC103-082	CF1/4-82	ASE	4700-15-8209	3
R16	RES, C, 1/4W, 5%, 56 RC103-056	CF1/4-56	ASE	4700-15-5609	1
R18	RES, C, 1/4W, 5%, 4.7K RC103-247	CF1/4-4.7K	ASE	4700-15-4701	1
R19	RES, C, 1/2W, 5%, 560 RC105-156	CF1/2-560	ASE	4700-25-5600	1
<b>WAVETEK PARTS LIST</b>		TITLE DLX HAR MKR, M106	ASSEMBLY NO. 1114-00-0152		REV B
			PAGE: 4		

REFERENCE DESIGNATORS	PART DESCRIPTION	ORIG-MFGR-PART-NO	MFGR	WAVETEK NO.	QTY
R23	RES. C, 1/4W, 5%, 150 RC103-115	CF1/4-150	ASE	4700-15-1500	1
R27 R28 R29	RES. C, 1/4W, 5%, 100K RC103-410	CF1/4-100K	ASE	4700-15-1003	3
R30	RES. C, 1/4W, 5%, 22K RC103-322	CF1/422K	ASE	4700-15-2202	1
R31	RES. C, 1/8W, 5%, 4.7K RC101-247	CF1/8-4.7K	ASE	4700-05-4701	1
R32	RES. C. 1/8W 5% 470	CF1/8-470	ASE	4700-05-4700	1
R33	RES. C, 1/8W, 5%, 2.2K RC101-222	CF1/8-2.2K	ASE	4700-05-2201	1
R34	RES. 1/8W, 5, 82-DHM	CF1/8-82	ASE	4700-05-8209	1
R35	RES. C, 1/4W, 5%, 330 RC103-133	CF1/4-330	ASE	4700-15-3300	1
T01	RF XFMR FROM: 1813-00-0007	1210-40-0012	W-I	1210-40-0012	1
X1	CRYSTAL. XX000-331	X33W-00.00000	W-I	2310-00-0331	1
21	PC ASSY	1218-00-1180	W-I	1218-00-1180	1
<b>WAVETEK PARTS LIST</b>		TITLE DLX HAR MKR, M106	ASSEMBLY NO. 1114-00-0152		REV B
			PAGE: 5		

REFERENCE DESIGNATORS	PART DESCRIPTION	ORIG-MFGR-PART-NO	MFGR	WAVETEK NO.	QTY
C101 C103 C104 C106 C107 C108 C115	CAP, ELECT, 1MF, 25V CE120-001	162D105X9025BC2	SPR	1510-21-7010	7
C102	CAP, CER, 3.3PF, 1KV CD101-R33	10TCC-V33	SPR	1510-10-0339	1
C109 C112 C120 C123	CAP, CER, .01MF, 100V CD103-310	68U103M	MDC	1510-10-2103	4
C110	CAP, CER, 4.7PF, 1KV CD101-R47	10TCC-V47	SPR	1510-10-0479	1
C111 C124 C125	CAP, VAR, 3.5-13PF250V CV101-013	7S-TRIKO-02-3.5-13PF	STR	1510-70-0130	3
C113 C119	CAP, CER, 360PF, 1KV CD102-136	60U361M	MDC	1510-10-1361	2
C114 C118	CAP, CER, 470PF, 1KV CD102-147	60U471M	MDC	1510-10-1471	2
C116	CAP, CER, .002MF, 1KV CD102-220	5GAD20	SPR	1510-10-1202	1
C121	CAP, CER, 120PF, 1KV CD102-112	60U121M	MDC	1510-10-1121	1
CR101 CR102 CR103 CR111 CR112	DIODE DG109-140	1N4148	FCD	4807-01-0914	5
CR106	DIODE DG100-821	1N82AG	G-I	4807-01-0082	1
CR107 CR108 CR109 CR110	DIODE DG000-007	5082-2800	H-P	4809-02-0001	4
<b>WAVETEK</b> <b>PARTS LIST</b>		TITLE PC ASSY	ASSEMBLY NO. 1218-00-1180  PAGE: 1		REV D

REFERENCE DESIGNATORS	PART DESCRIPTION	ORIG-MFGR-PART-NO	MFGR	WAVETEK NO.	QTY
IC101	IC, IC000-017	N82S90A	SIG	8000-82-9001	1
IC102	IC, IC000-016	N8290A	SIG	8000-82-9000	1
IC103	IC, IC000-012	SN7404N	T-I	8000-74-0400	1
IC104	IC, IC000-005	RC4558DN	RAY	7000-14-5800	1
L108	CHOKE .47MH 10% LA005-R04	08NR47K	ASE	1810-03-0478	1
L301 L302 L303	TDRRID, 10 TURN	LA009-010-1	HYT	1810-05-0004	3
Q103 Q104 Q108 Q109	TRANS QA050-530	2N5053	APX	4901-05-0530	4
Q105 Q106 Q107 Q110	TRANS QA054-580	2N5458	MDT	4901-05-4580	4
Q111	TRANS QA054-610	2N5461	MDT	4901-05-4610	1
R101 R103	RES, 1/8W, 5.12K-OHM	CF1/8-12K	ASE	4700-05-1202	2
R105	RES, C, 1/4W, 5%, 390 RC103-139	CF1/4-390	ASE	4700-15-3900	1
R106	RES, C, 1/8W, 5%, 22 RC101-022	CF1/8-22	ASE	4700-05-2209	1
R107	RES, C, 1/8W, 5%, 47 RC101-047	CF1/8-47	ASE	4700-05-4709	1
R109 R112 R136 R140	RES, C, 1/8W 5% 470	CF1/8-470	ASE	4700-05-4700	4
<b>WAVETEK</b> <b>PARTS LIST</b>		TITLE PC ASSY	ASSEMBLY NO. 1218-00-1180  PAGE: 2		REV D



REFERENCE DESIGNATORS	PART DESCRIPTION	ORIG-MFGR-PART-NO	MFGR	WAVETEK NO.	QTY
R110 R113 R115 R116 R118 R134 R135 R138 R139	RES, C, 1/8W, 5%, 1K RC101-210	CF1/8-1K	ASE	4700-05-1001	9
R111	RES, C, 1/4W, 5%, 560 RC103-156	CF1/4-560	ASE	4700-15-5600	1
R114 R133 R137	RES, C, 1/4W, 5%, 180 RC103-118	CF1/4-180	ASE	4700-15-1800	3
R117 R120 R130 R144	POT, 20K, RP144-320	91WR20K	BEK	4610-00-4203	4
R119 R151	RES, C, 1/4W, 5%, 1K RC103-210	CF1/4-1K	ASE	4700-15-1001	2
R121 R122 R124 R127 R145	RES, C, 1/8W, 5%, 4.7K RC101-247	CF1/8-4.7K	ASE	4700-05-4701	5
R123 R126	RES, C, 1/8W, 5%, 22K RC101-322	CF1/8-22K	ASE	4700-05-2202	2
R125 R128 R129 R143	RES, C, 1/8W, 5%, 10M RC101-610	BB1065	A-B	4700-05-1005	4
R131 R141	RES, C, 1/4W, 5%, 1.5K RC103-215	CF1/4-1.5K	ASE	4700-15-1501	2
R132 R146	RES, C, 1/8W, 5%, 2K RC101-220	CF1/8-2K	ASE	4700-05-2001	2
R142	RES, C, 1/4W, 5%, 22K RC103-322	CF1/422K	ASE	4700-15-2202	1
<b>WAVETEK PARTS LIST</b>		TITLE PC ASSY	ASSEMBLY NO. 1218-00-1180  PAGE: 3		REV D

REFERENCE DESIGNATORS	PART DESCRIPTION	ORIG-MFGR-PART-NO	MFGR	WAVETEK NO.	QTY
R147 R148	RES, C, 1/4W, 5%, 10K RC103-310	CF1/4-10K	ASE	4700-15-1002	2
R149	RES. 1/8W, 5, 330-OHM	CF1/8-330	ASE	4700-05-3300	1
R150	RES, C, 1/4W, 5%, 10M RC103-610	CB1065	A-B	4700-15-1005	1
T101 T102	RF XFMR FROM: 1813-00-0007	1210-40-0016	W-I	1210-40-0016	2
<b>WAVETEK PARTS LIST</b>		TITLE PC ASSY	ASSEMBLY NO. 1218-00-1180  PAGE: 4		REV D

# SECTION 7

## SCHEMATICS

### 7.1 INTRODUCTION

This section contains all schematics for the instrument. A schematic index is given in Section 7.3.











### 7.2 SCHEMATIC NOTES

The following notes and abbreviations pertain to all sche-

matics. Additional notes pertaining to specific schematics are included on each schematic if required.

Unless otherwise noted, resistor values are given in ohms, capacitor values are given in pF, and inductor values are given in  $\mu\text{H}$ .

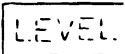
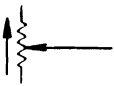
#### SYMBOL NOTES

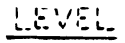
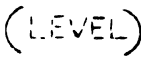
	Denotes DC voltage reading unless otherwise specified.		Coaxial jack
	Denotes high-impedance crystal detector reading in volts unless otherwise specified.		Coaxial plug
	Denotes 50 ohm crystal detector reading in volts unless otherwise specified.		Coaxial cable
	Signal or voltage source.		Factory adjusted part.
	Connects to indicated signal or voltage source.		Denotes a front-panel device.
	Arrow indicates clockwise rotation of wiper.		Denotes a rear-panel device.
			Denotes a printed circuit board adjustment or accessible module adjustment.
			Denotes an internal module adjustment not accessible without removing module cover.

#### ABBREVIATION CODE

A	ampere	IF	intermediate frequency	$\Omega$	ohm
AC	alternating current	J	jack	OC	opto-coupler
C	capacitor	K	relay	P	plug
ccw	counterclockwise	kHz	kilohertz	p	peak
CR	diode	k $\Omega$	kilohm	pp	peak-to-peak
CW	continuous wave	kV	kilovolt	pF	picofarad
cw	clockwise	kW	kilowatt	Q	transistor
dB	decibel	L	inductor	R	resistor
dBc	dB referred to carrier	M	meter	RF	radio frequency
dBm	dB referred to 1 mW	MHz	megahertz	RMS	root-mean-square
dBmV	dB referred to 1 mV	M $\Omega$	megohm	R.P.	rear panel
DC	direct current	mA	milliampere	S	switch
DS	indicating device, lamp	mH	millihenry	T	transformer
F	farad	mV	millivolt	T.P.	test point
F.P.	front panel	mW	milliwatt	V	volt
H	henry	$\mu\text{F}$	microfarad	VA	voltampere
Hz	hertz	$\mu\text{A}$	microampere	W	watt
IC	integrated circuit	$\mu\text{H}$	microhenry	X	crystal

### 7.3 SCHEMATIC INDEX

The schematics appear in the following order.

ASSEMBLY	NAME
2002A	Wiring Diagram
2002A	Marker System Diagram
DPS2A	Power Supply
M101B	Sweep Rate
M102A	Sweep Drive
M103A	Sweep Drive
M104A	Leveler
M105	Marker Adder
M109	Sweep Oscillator 1
M110	Sweep Oscillator 2A, 2B, 3
MA111	Output Amplifier
M121	Modulator
M131	Band Select
M132	Interface
M6C	External Marker
M6H-1	Harmonic Marker (1 MHz)
M6H-5-50	Harmonic Marker (5-50 MHz)
M6S	Single Frequency Marker
M106	Deluxe Harmonic Marker

Printed circuit board layouts, where applicable, are shown opposite their corresponding schematics.

# 2002A WIRING DIAGRAM

REV. \_\_\_\_\_

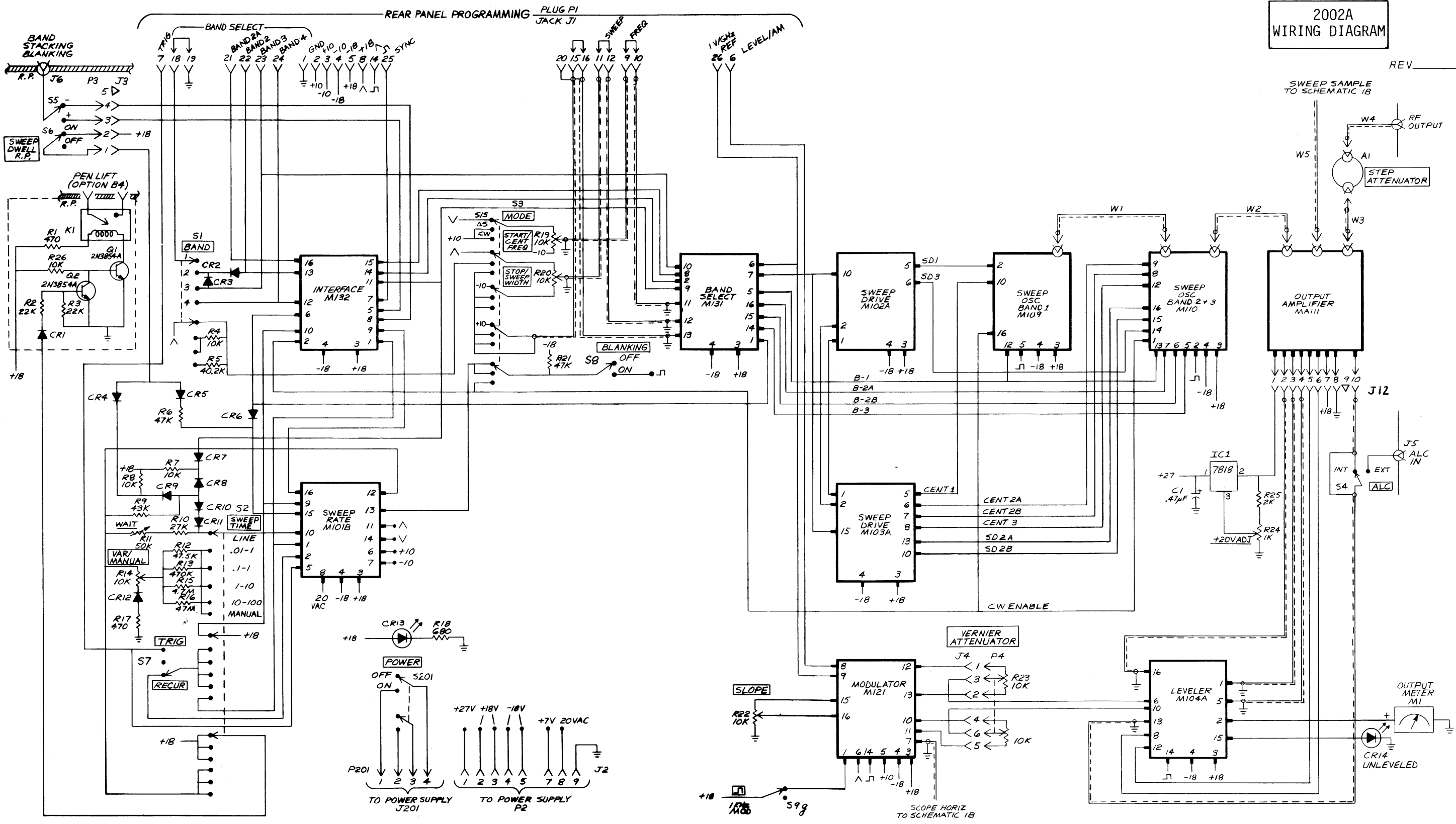

REV \_\_\_\_\_

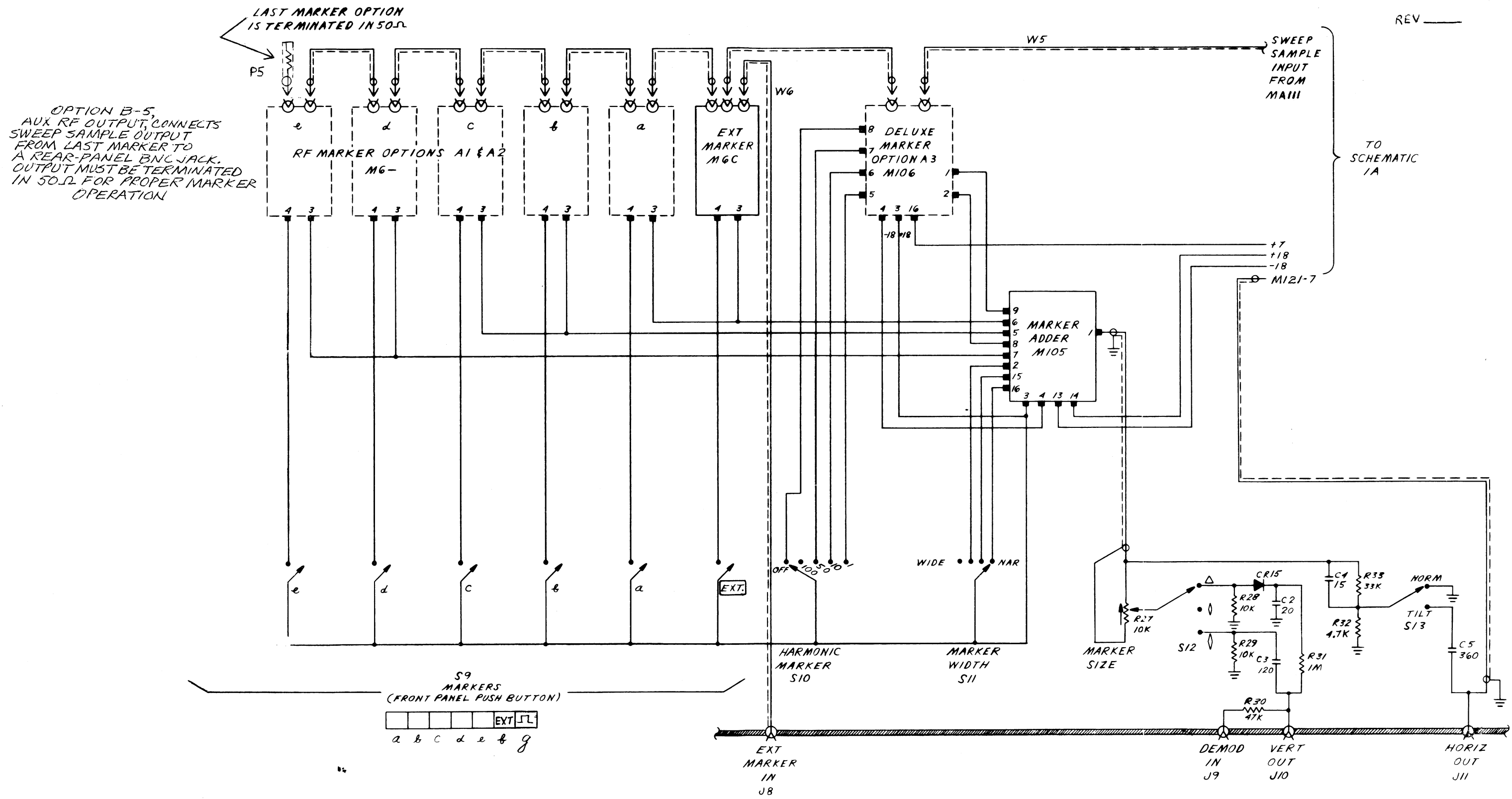

# DPS2A

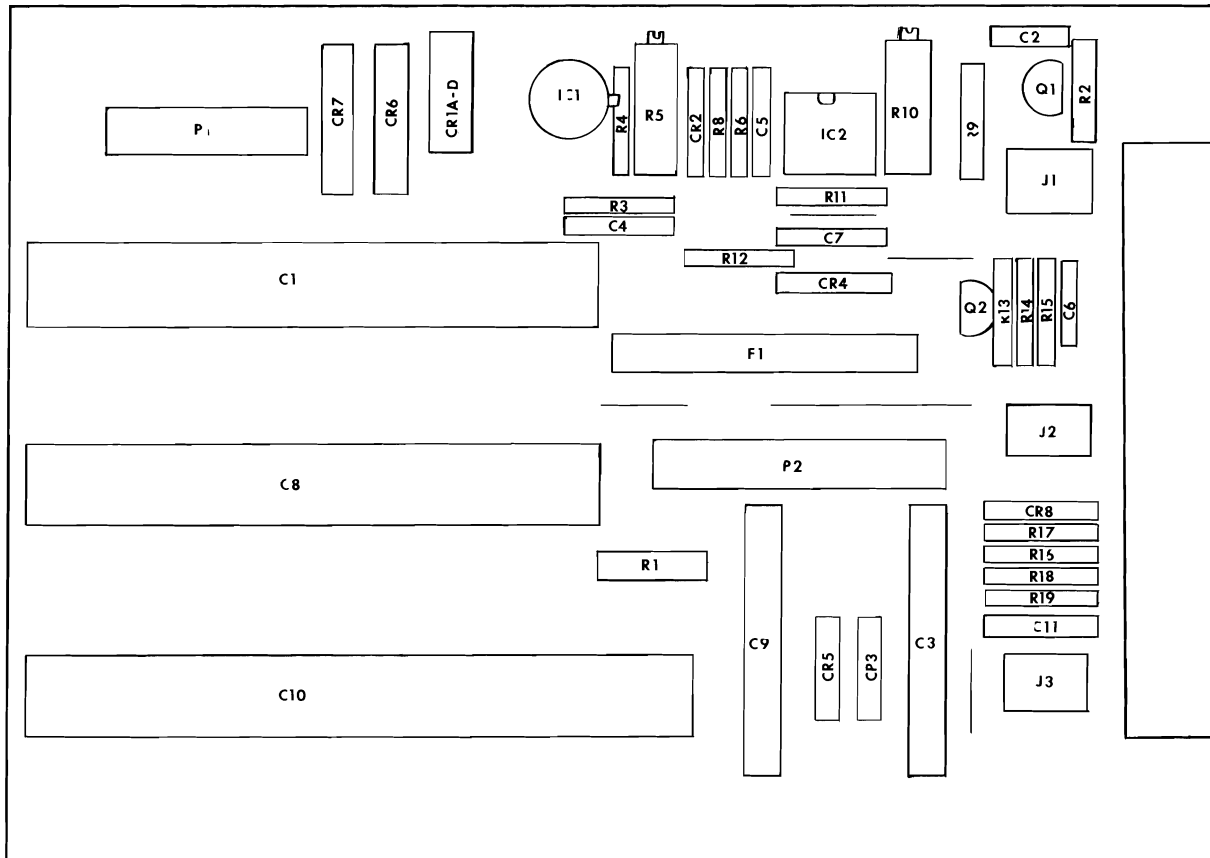

REV A  
DPS2A  
POWER SUPPLY

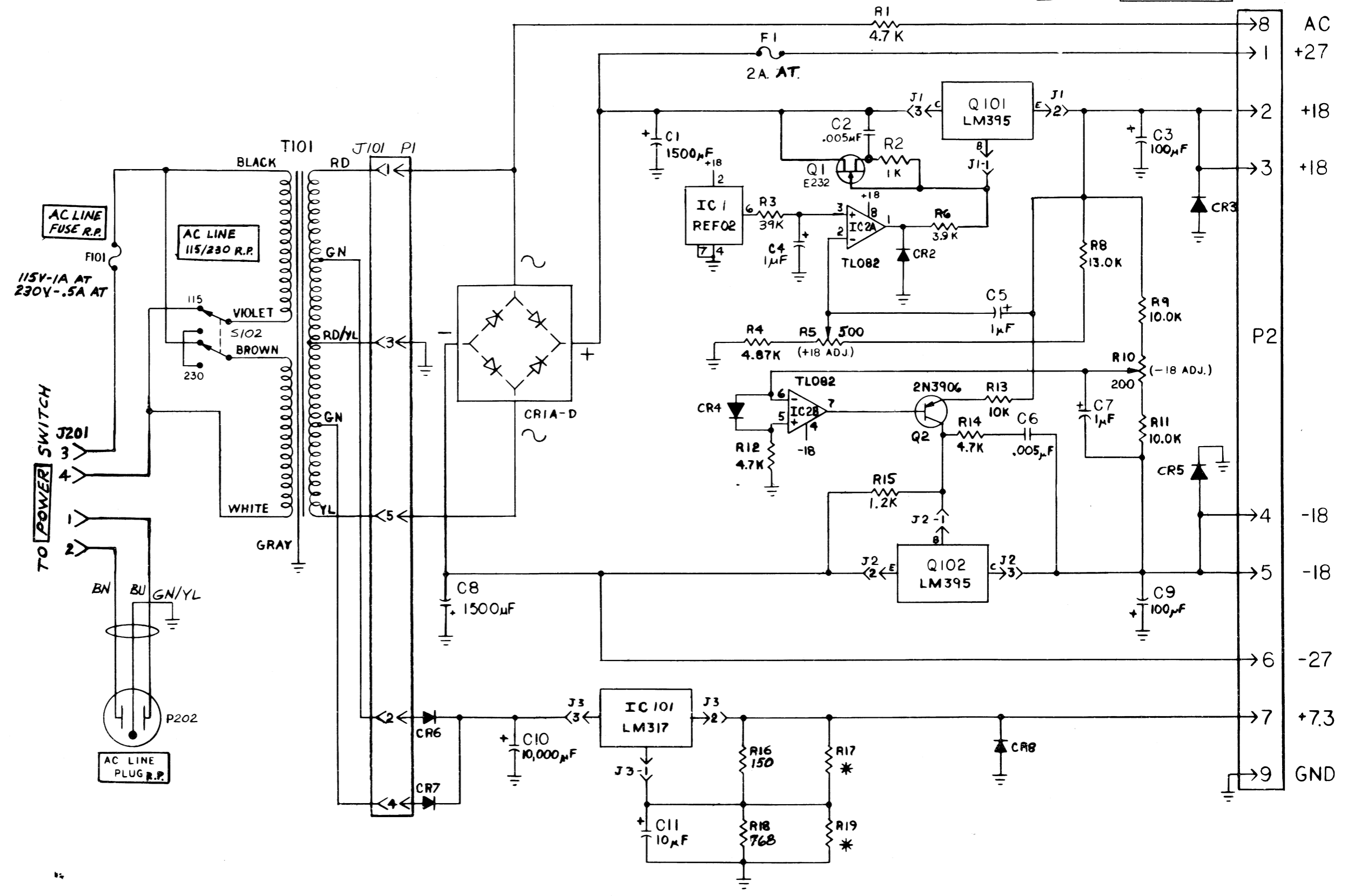

# M 101B

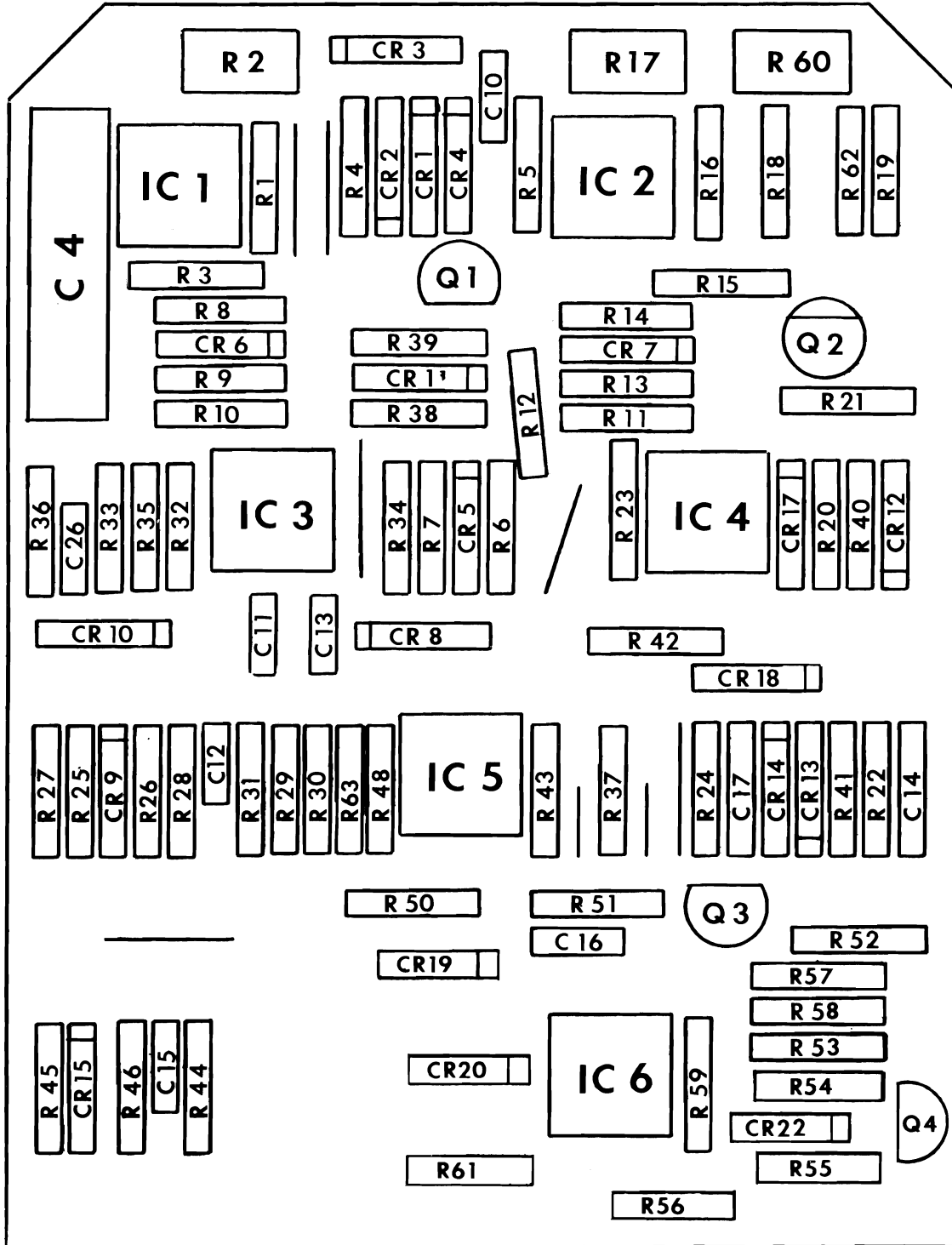



M101B  
SWEEP RATE

REV B

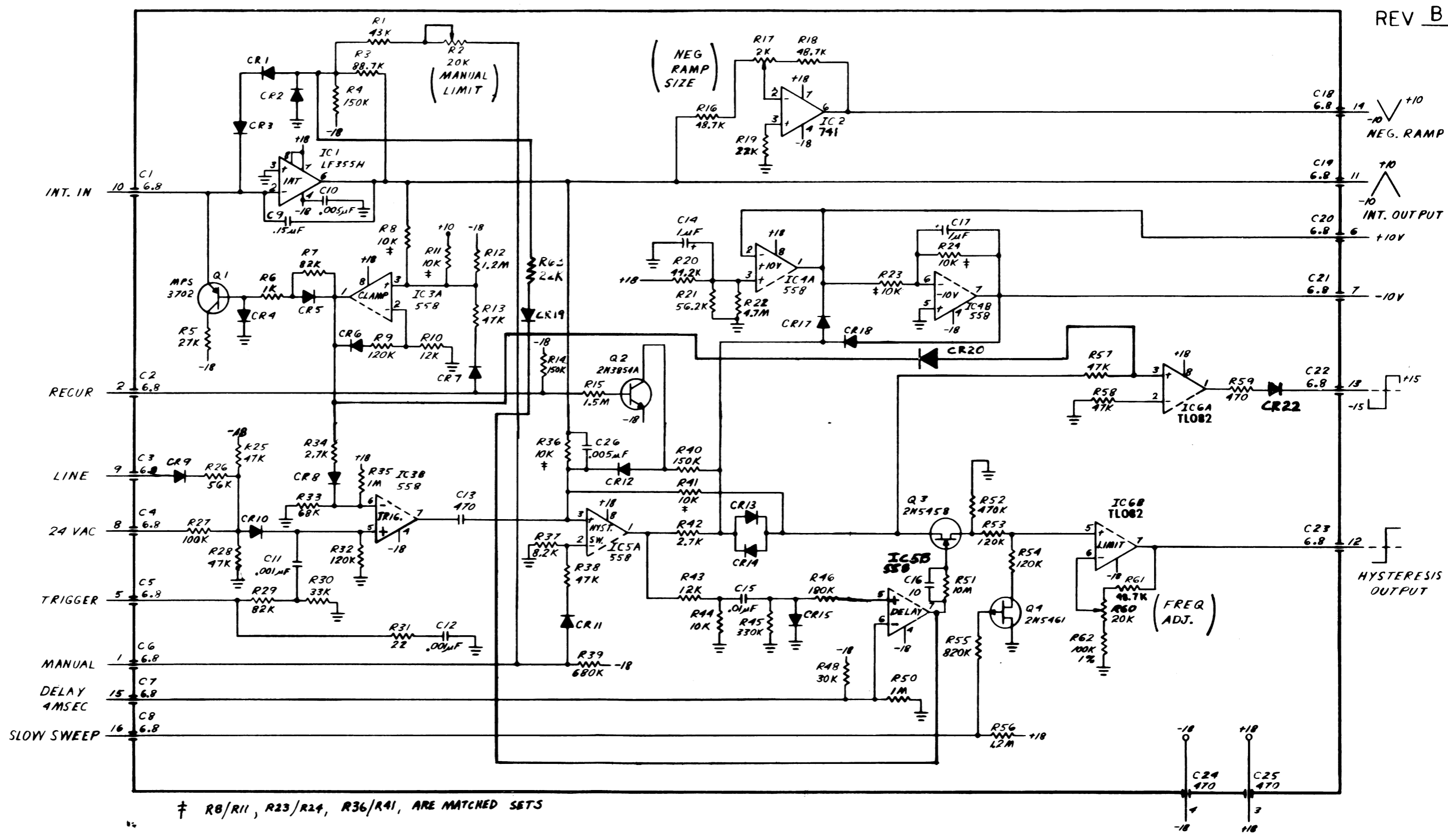

# M102A

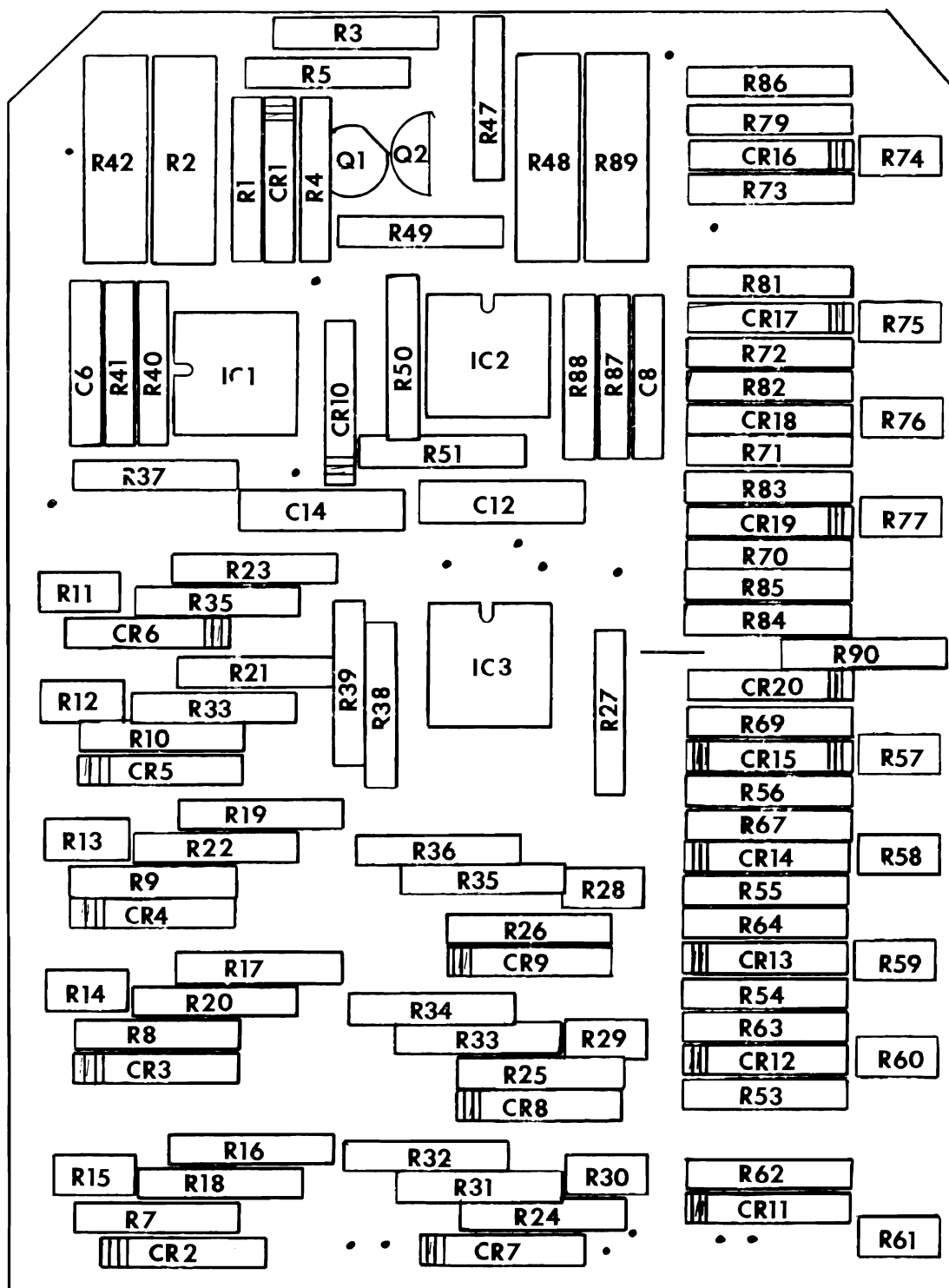

# M102A SWEEP DRIVE

REV

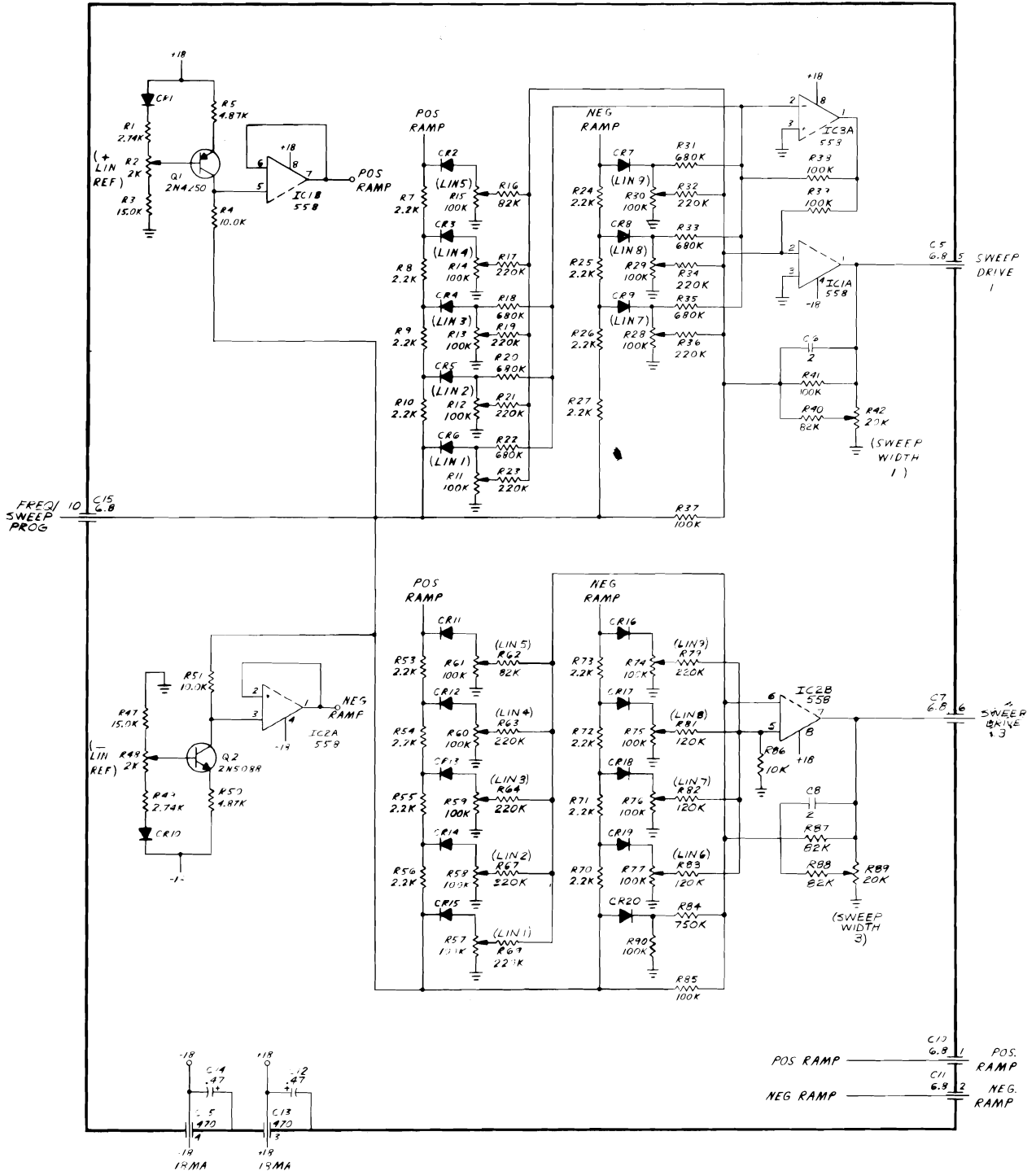

# M103A

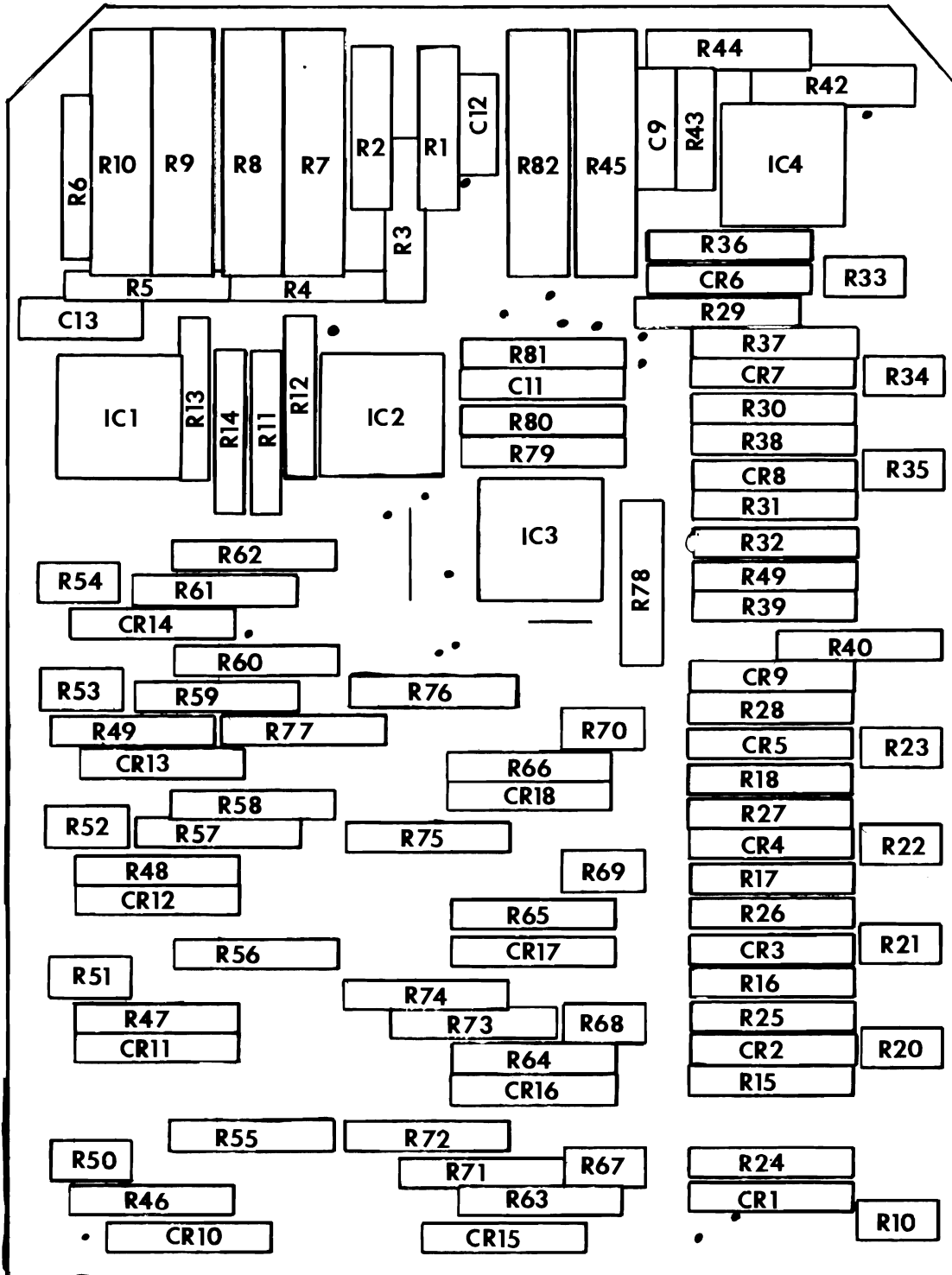

# M103A SWEEP DRIVE

REV

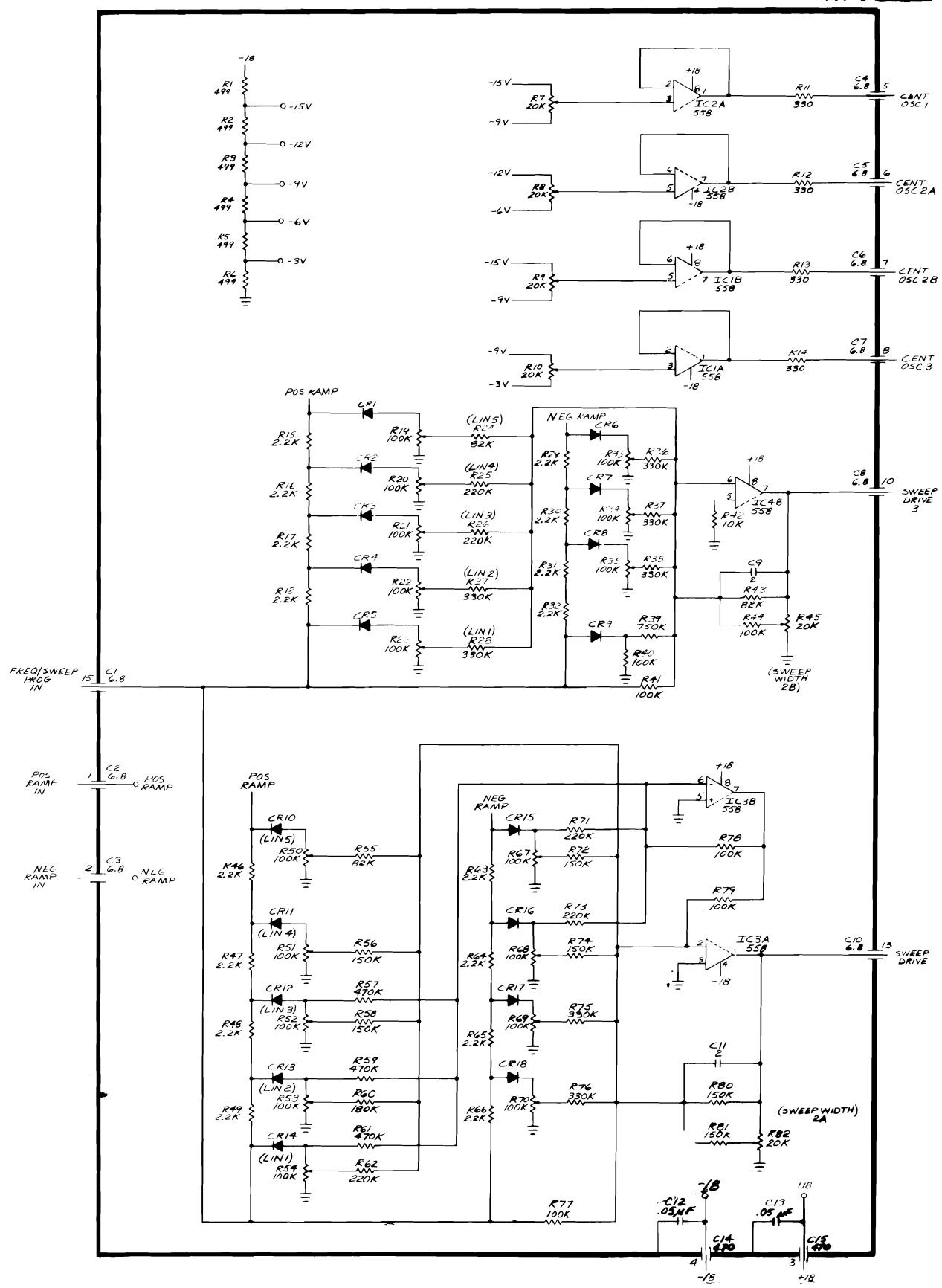



M104A  
LEVELER

REV. A

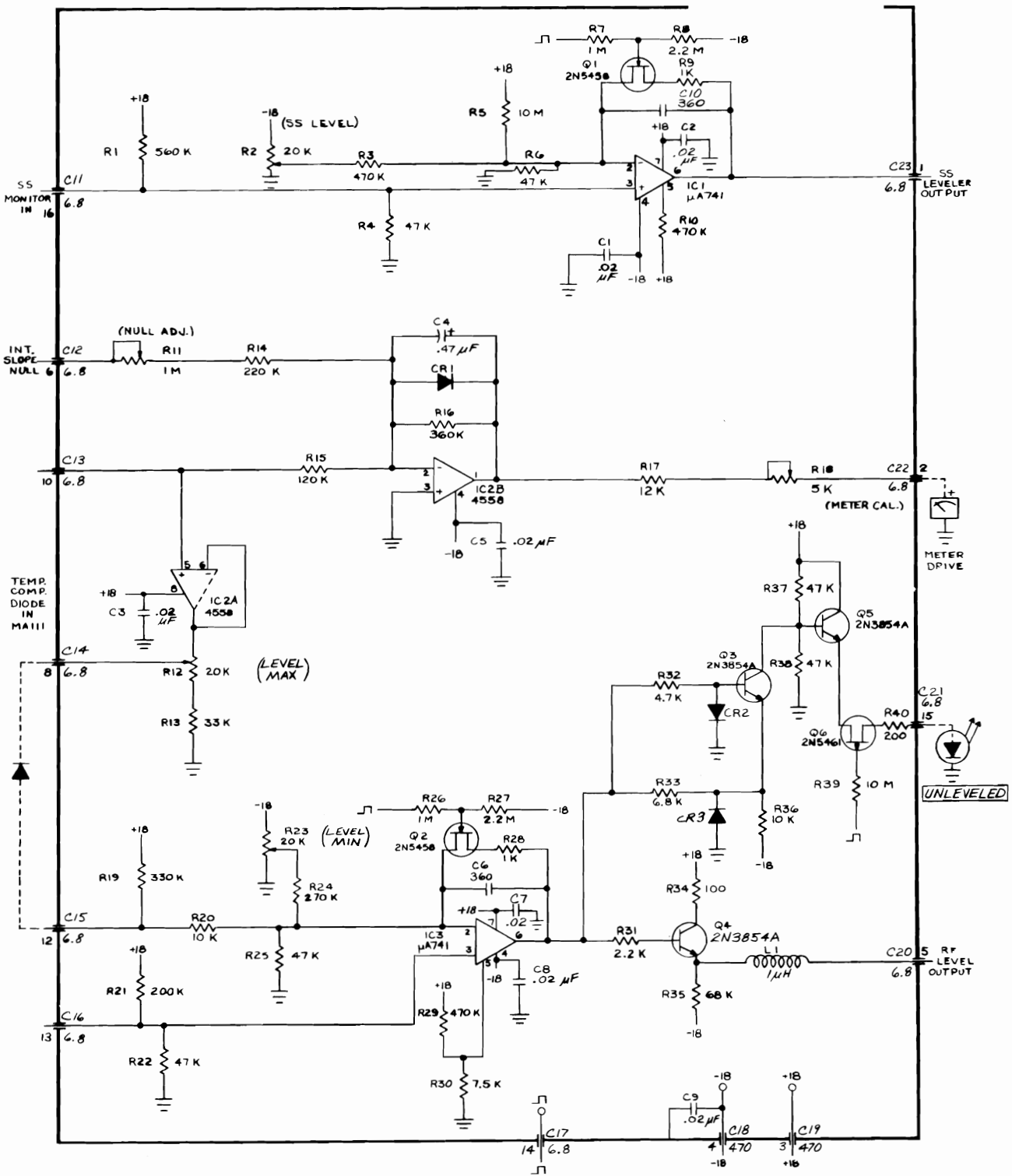

# M 105

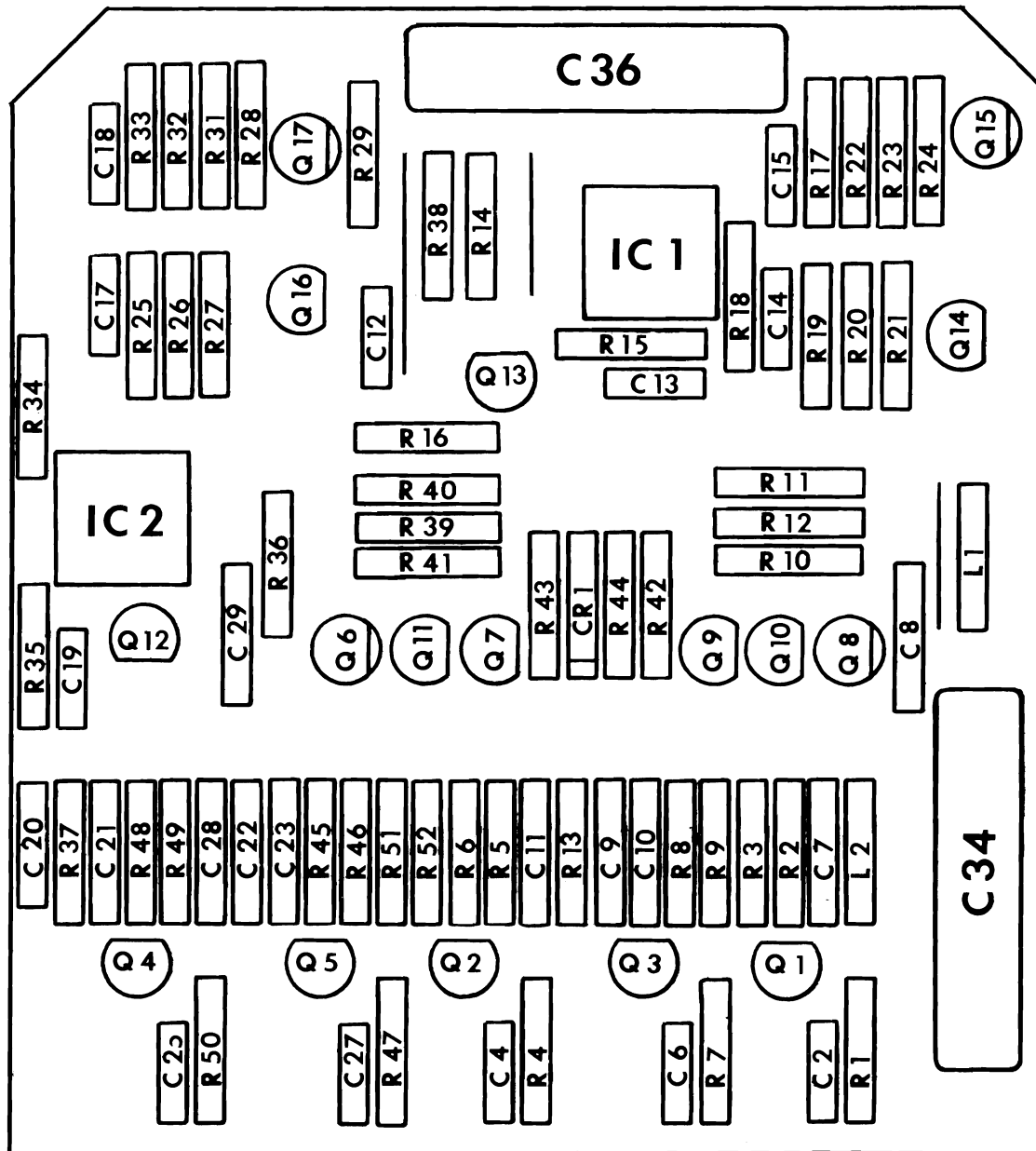



M105  
MARKER ADDER

REV \_\_\_\_\_

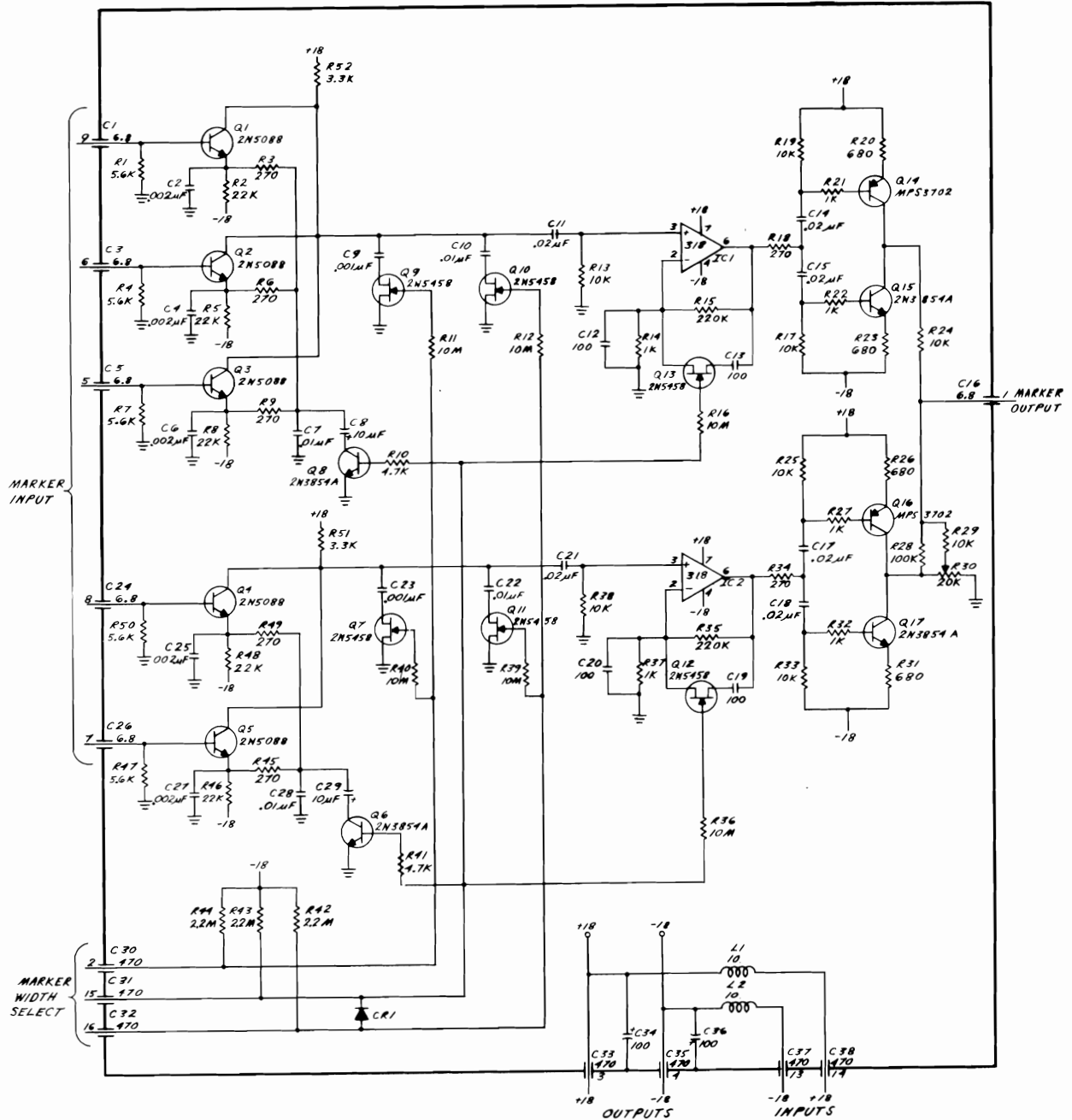

M109  
SWEEP OSC. 1

REV B

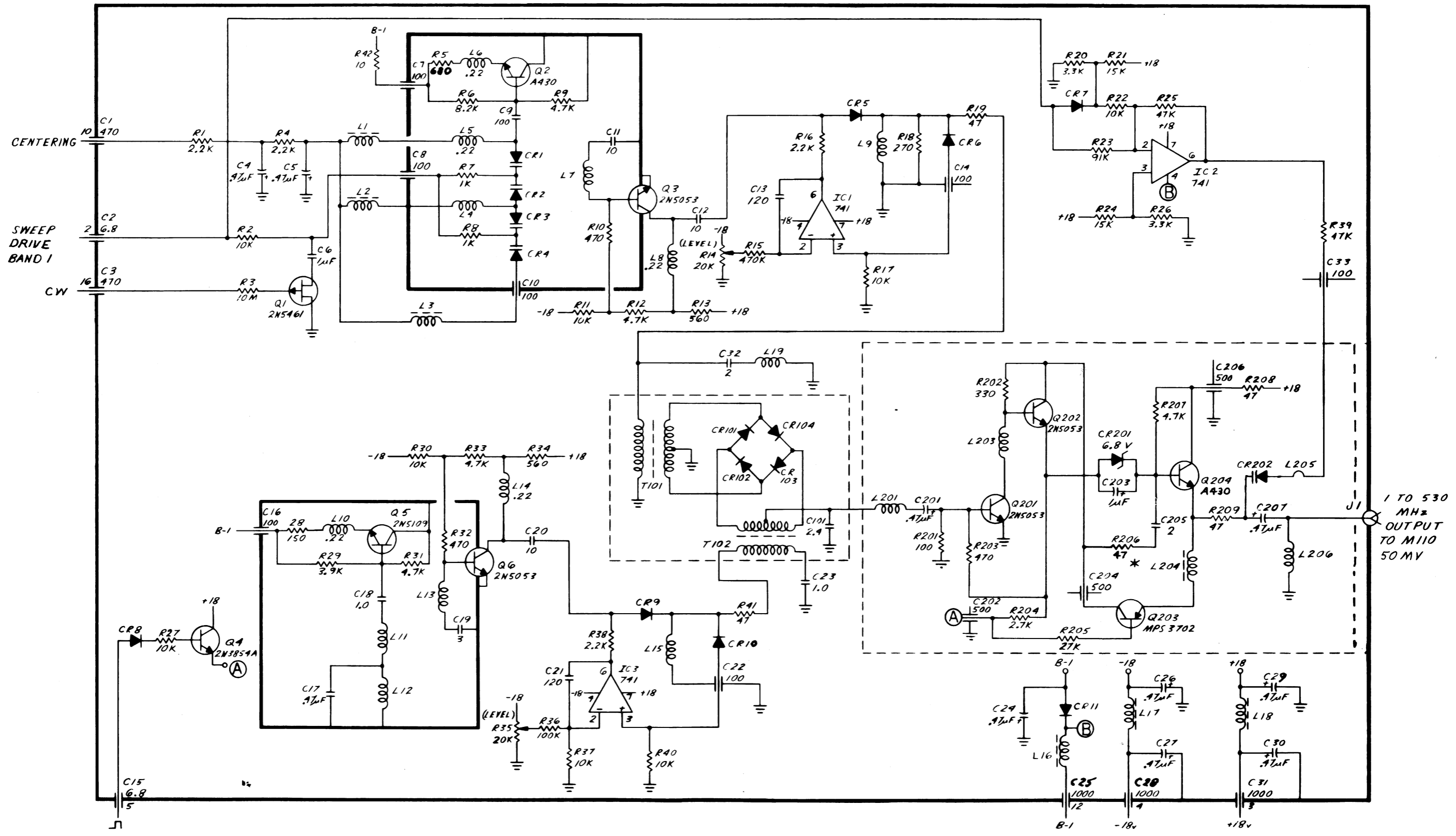

M110  
SWEEP OSC. 2A, 2B, 3

REV B

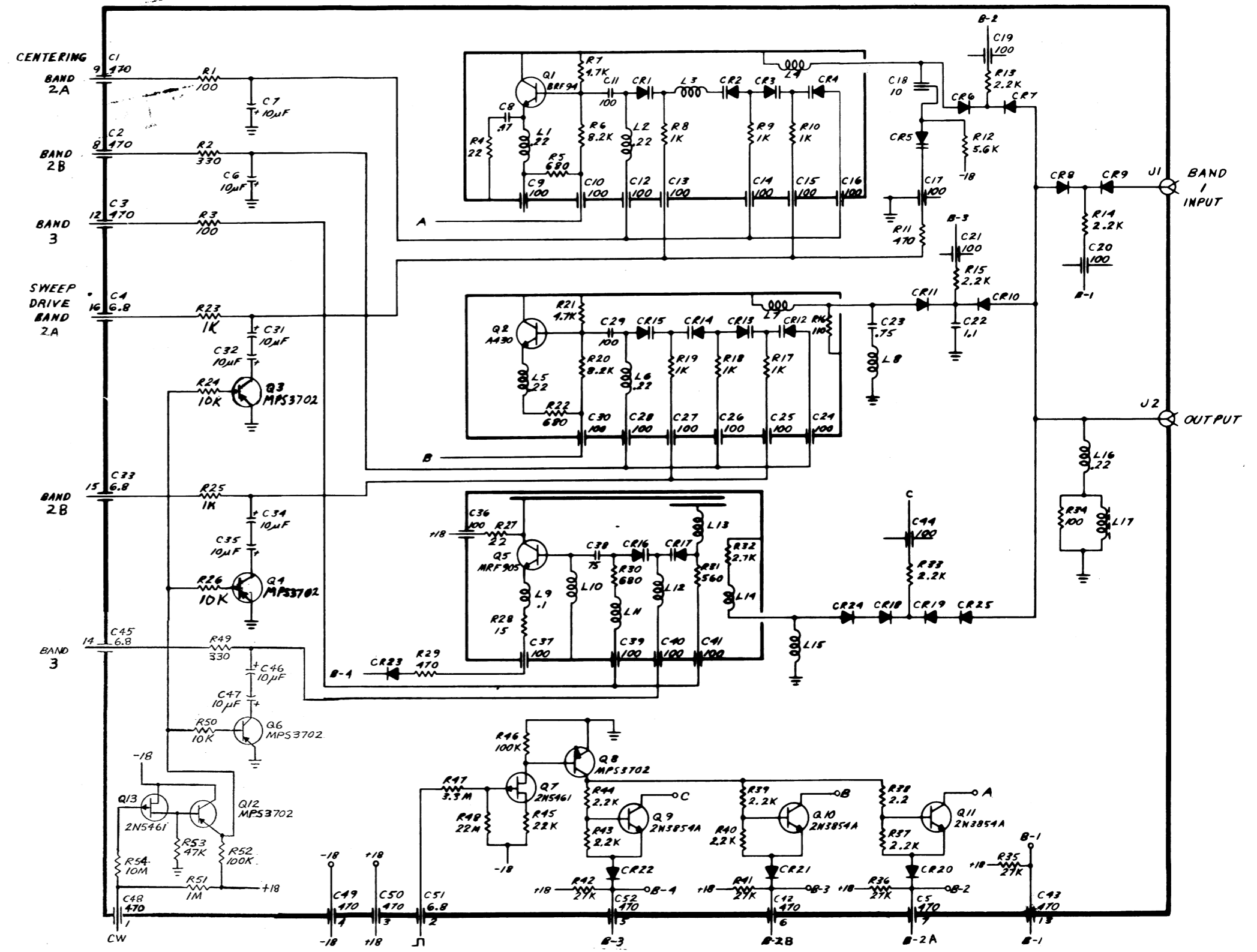

MA111  
OUTPUT AMP

REV

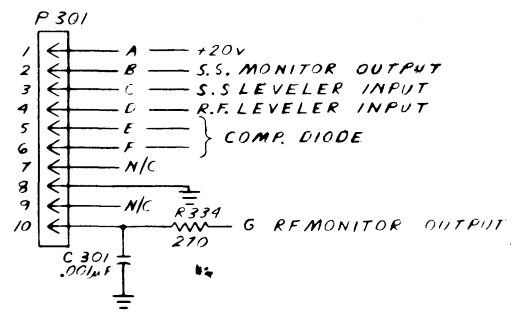
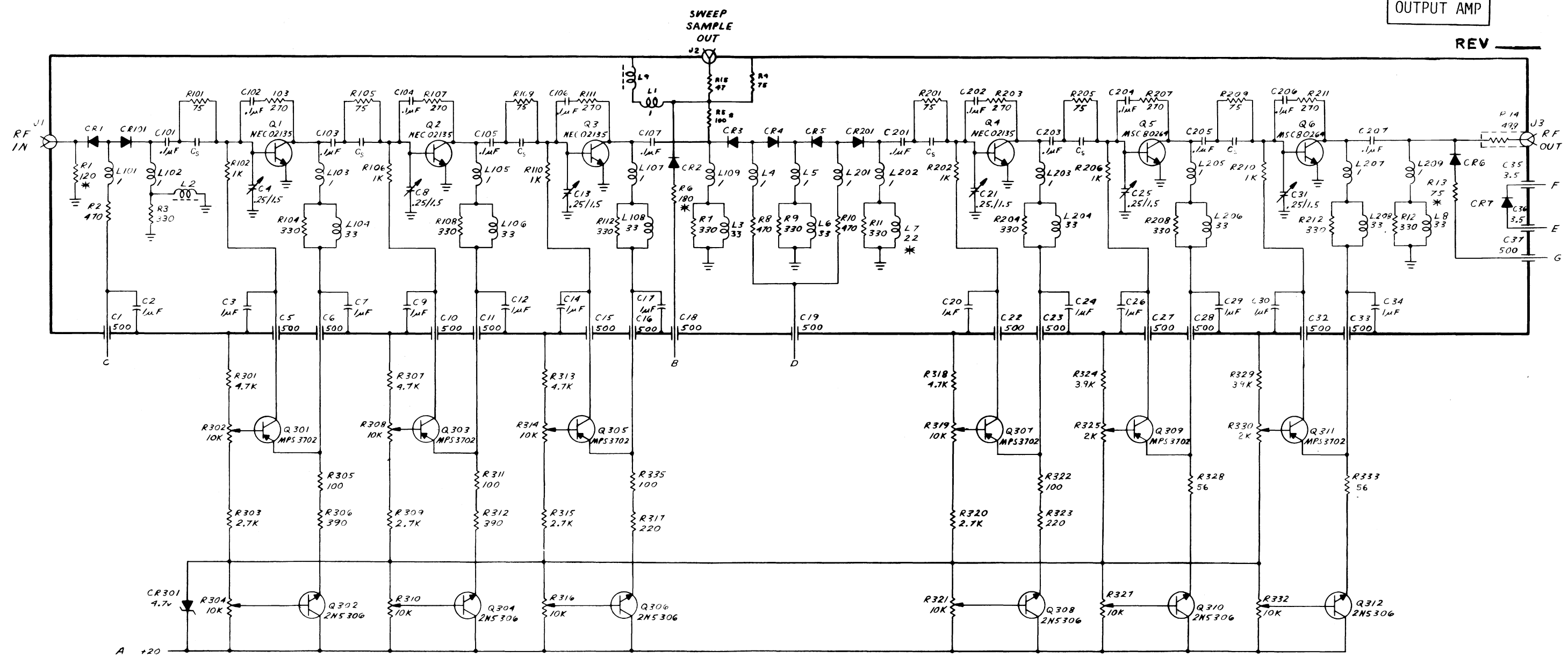

# M121

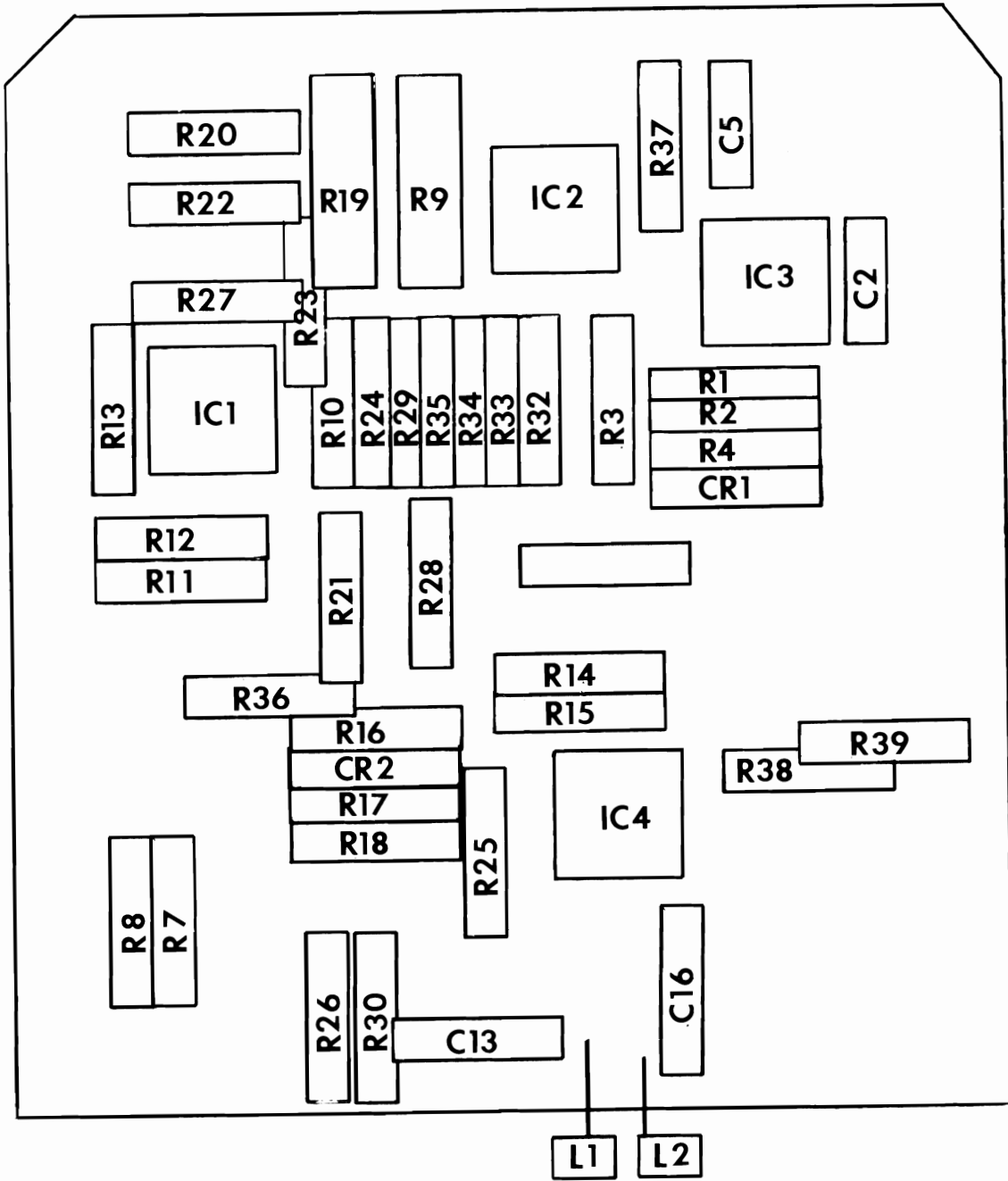

M121  
MODULATOR

REV C

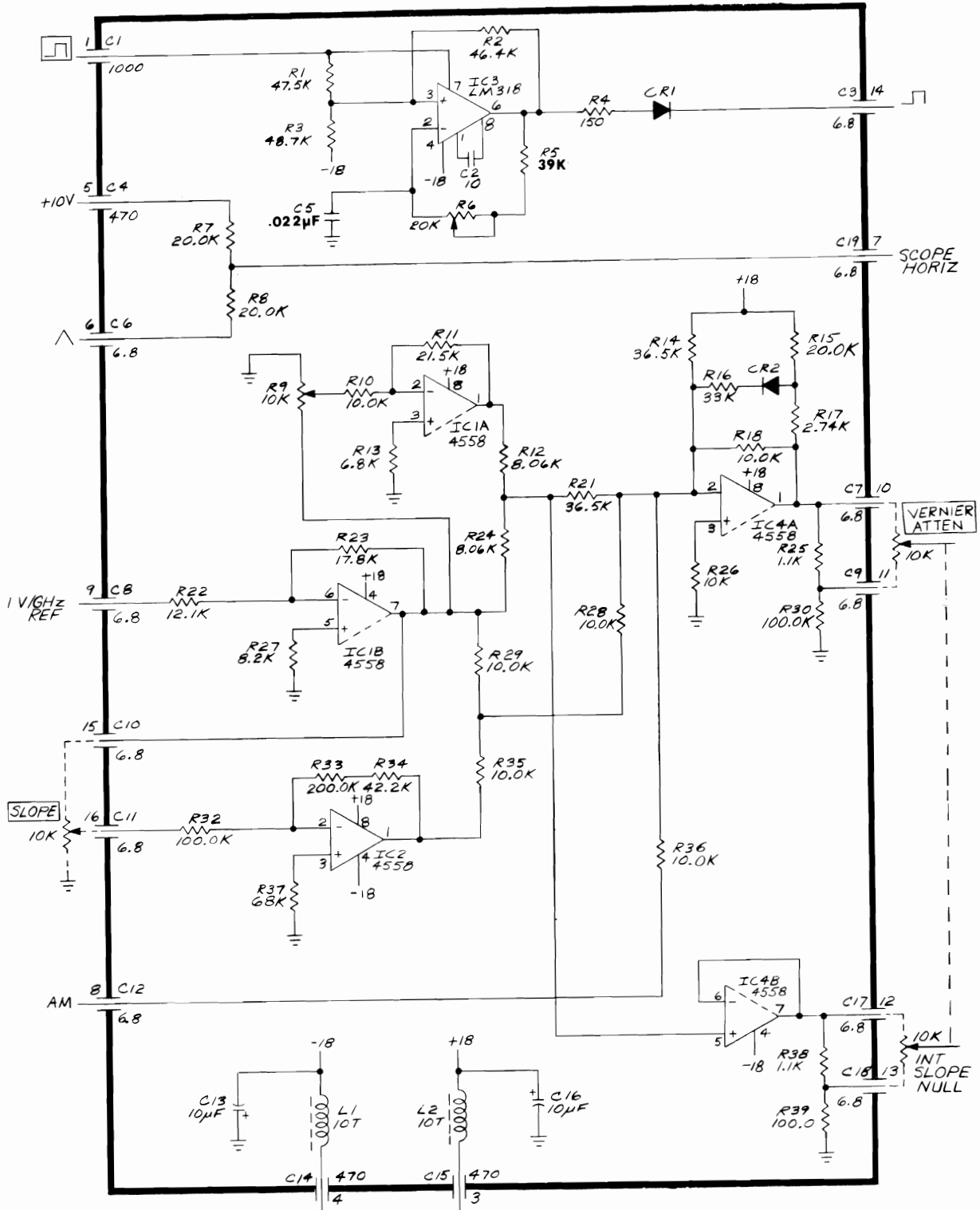

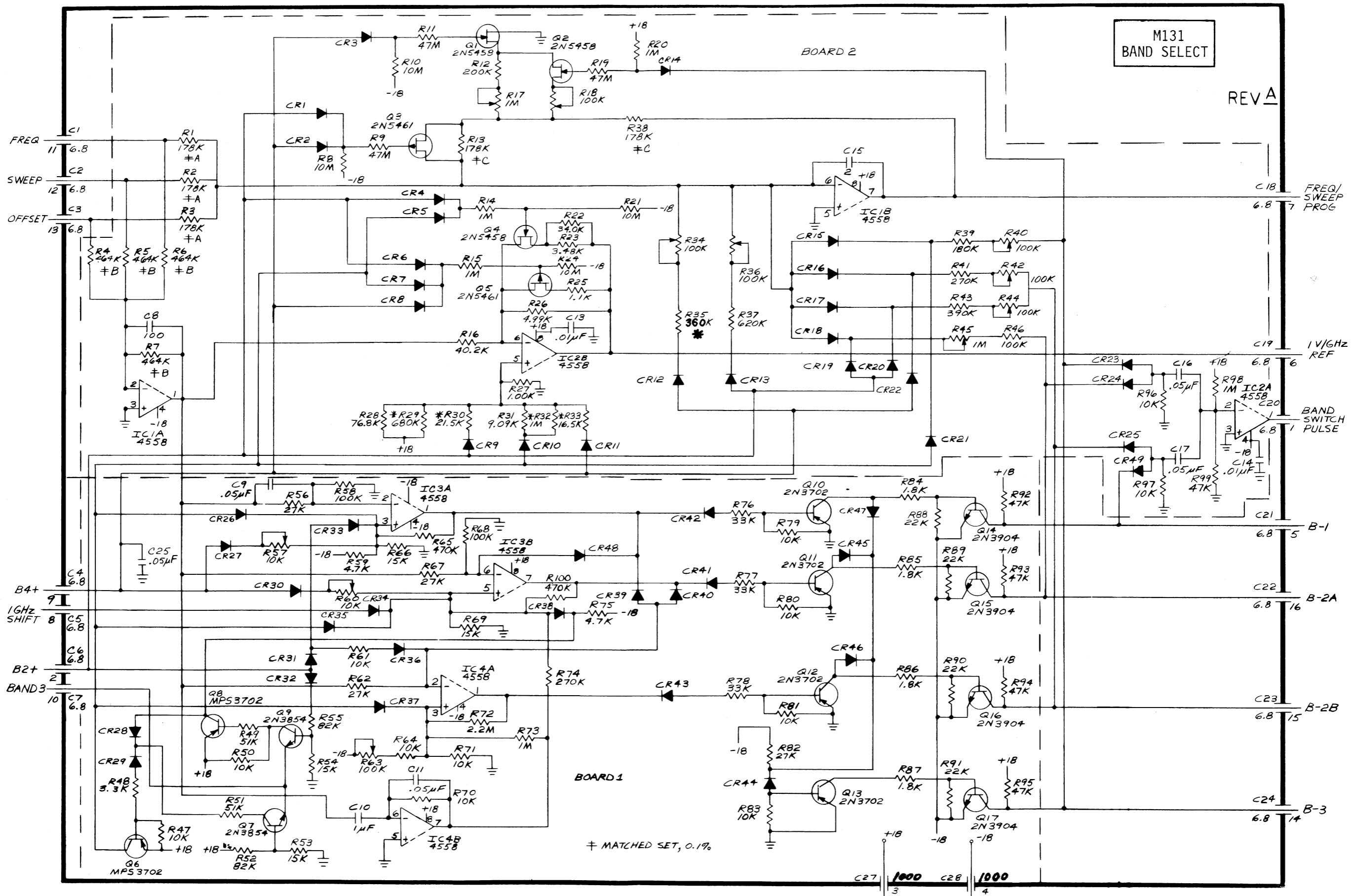





M132  
INTERFACE

REV \_\_\_\_\_

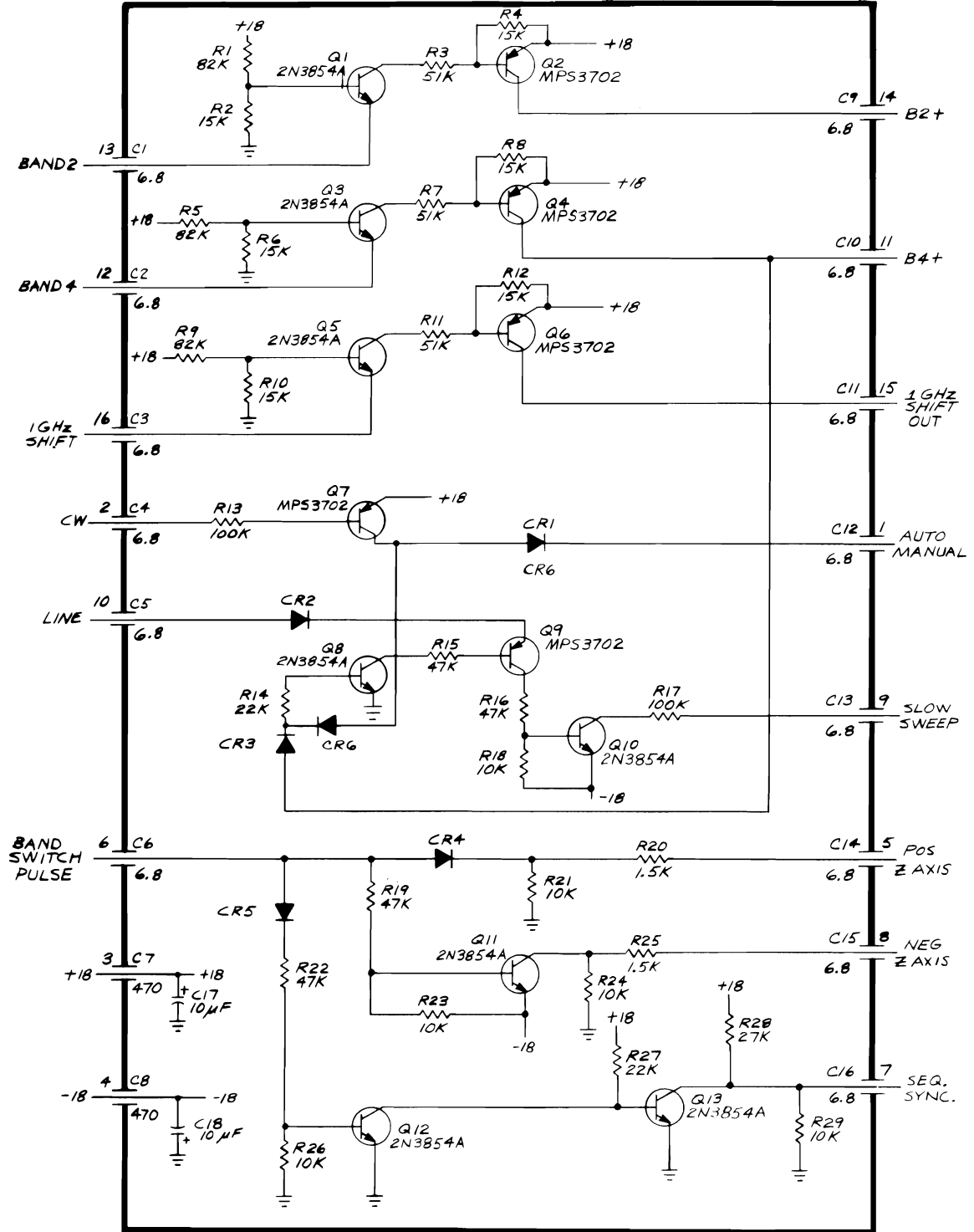

M6C  
EXT. MARKER

REV A

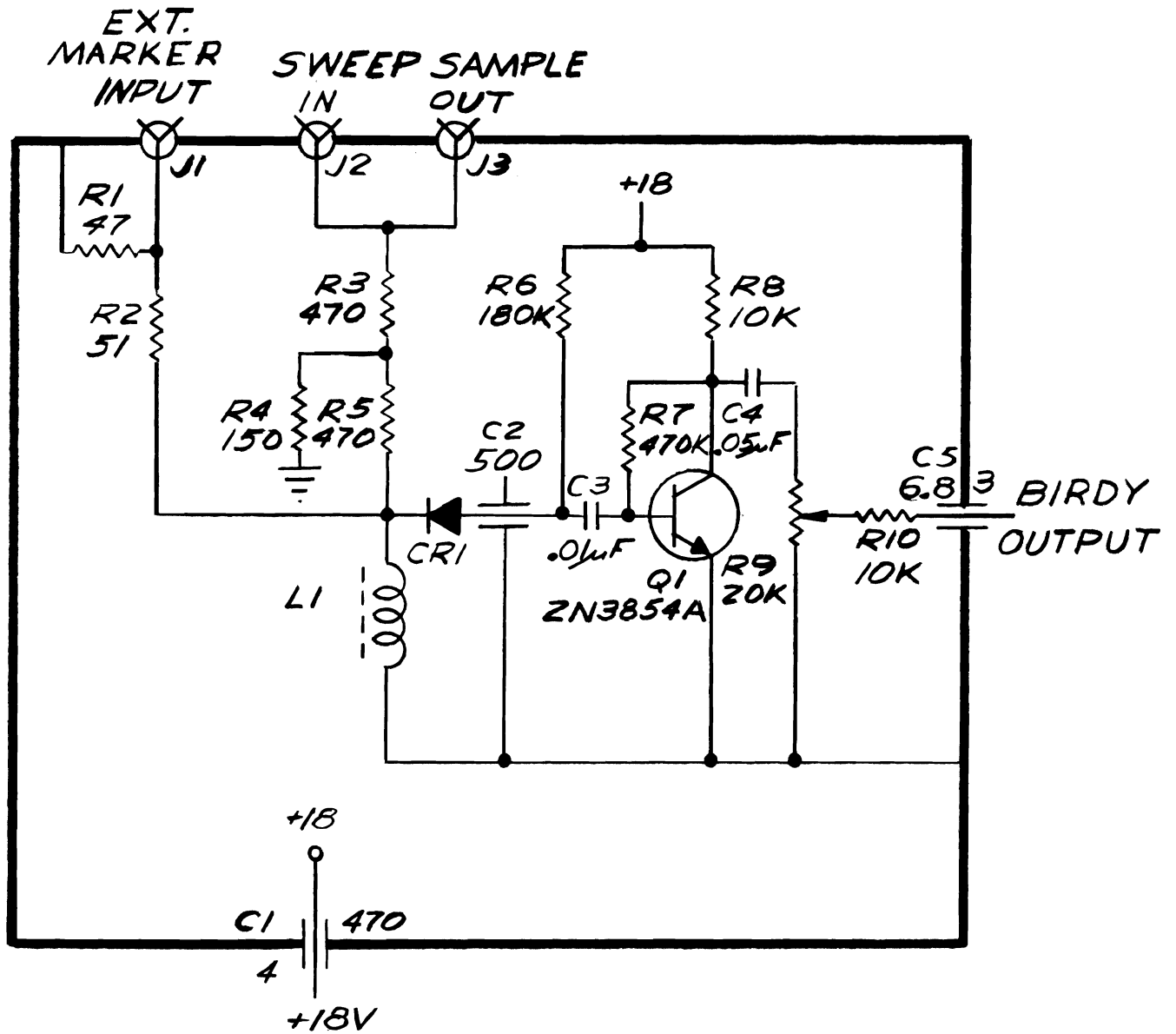

M6H-1  
HAR. MARKER (1 MHz)

REV E

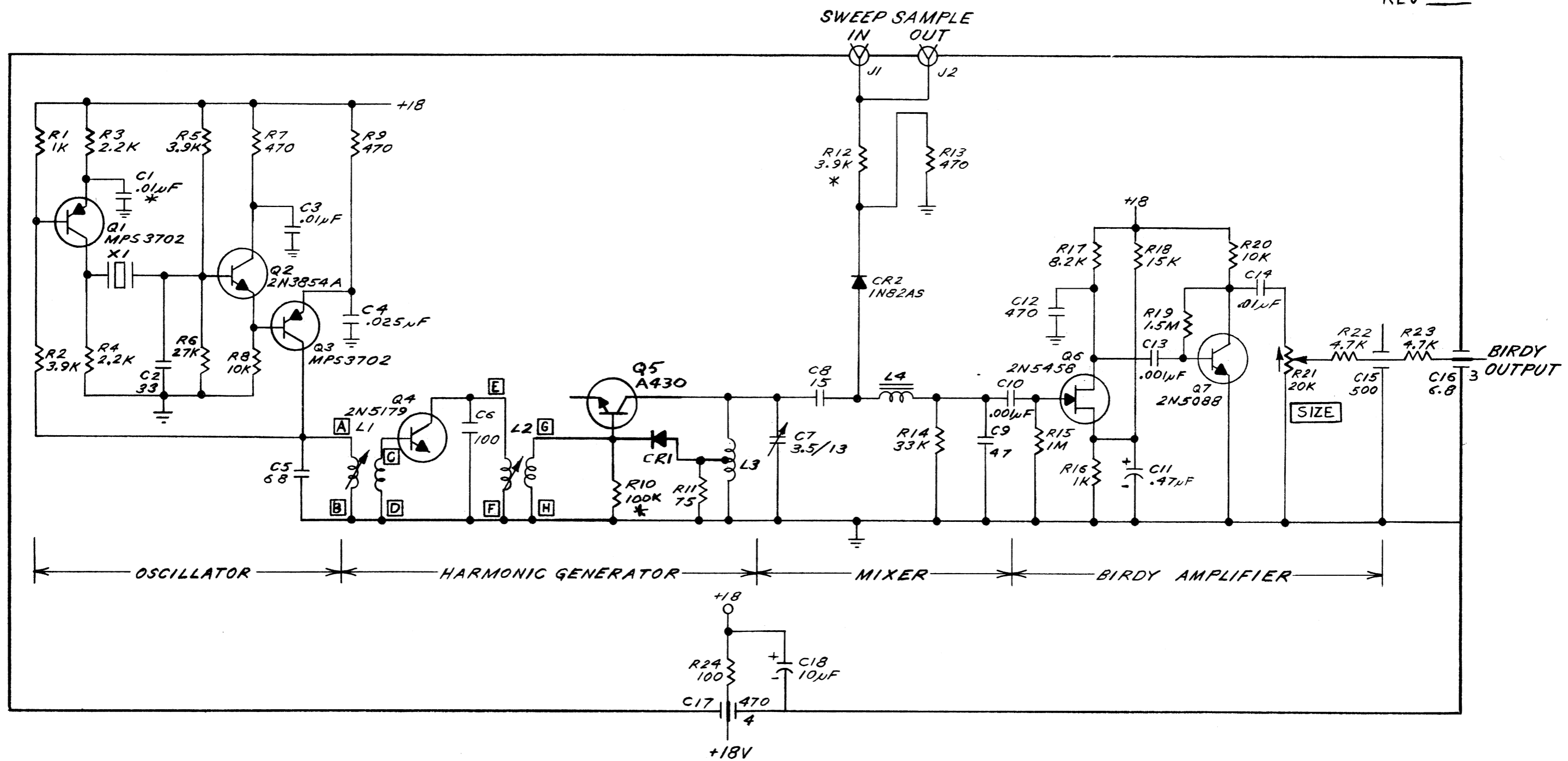

M6H-5-50  
HAR. MARKER (5-50 MHz)

REV   D  

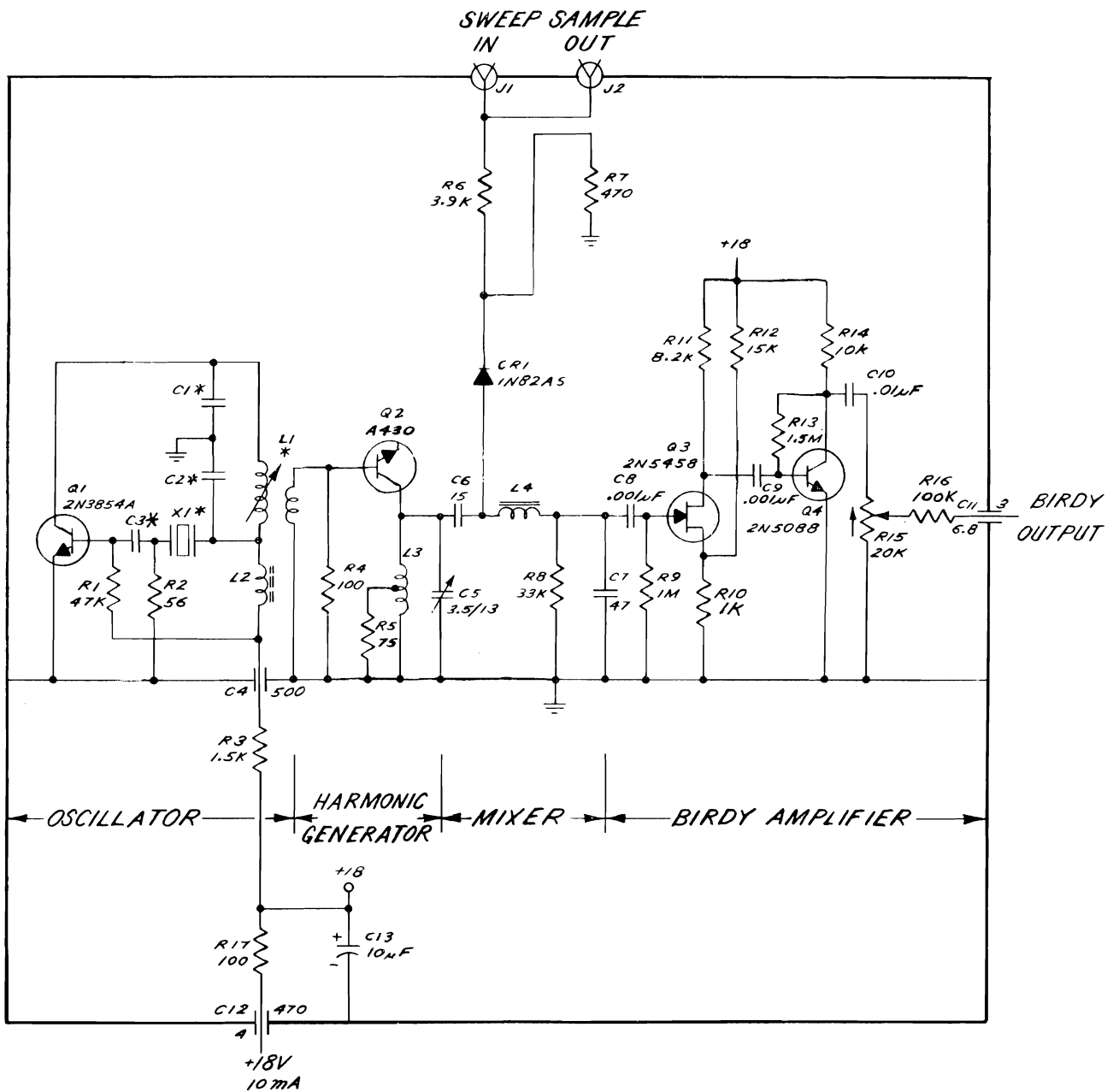

M6S  
S.F. MARKER

REV \_\_\_\_\_

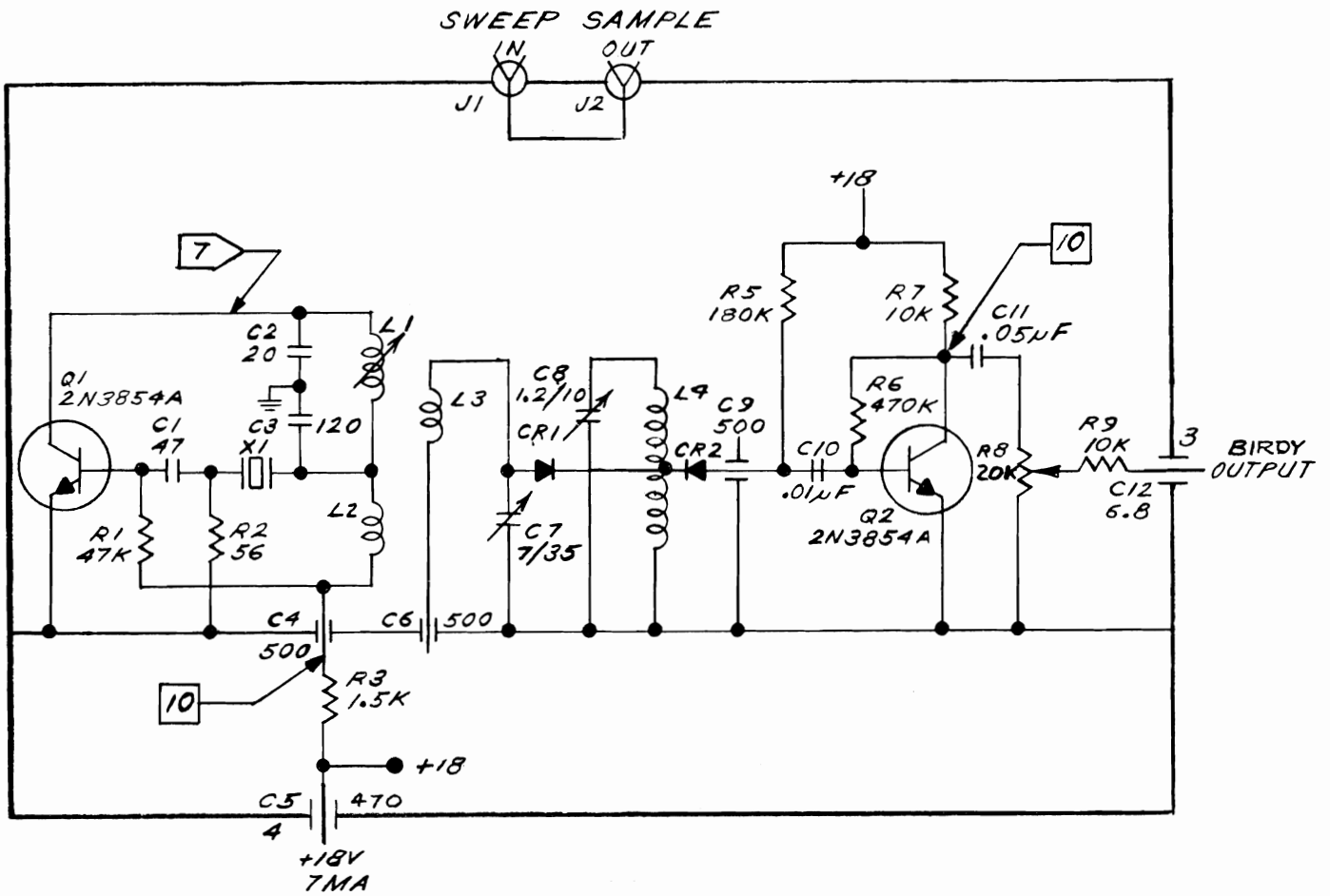

# M106

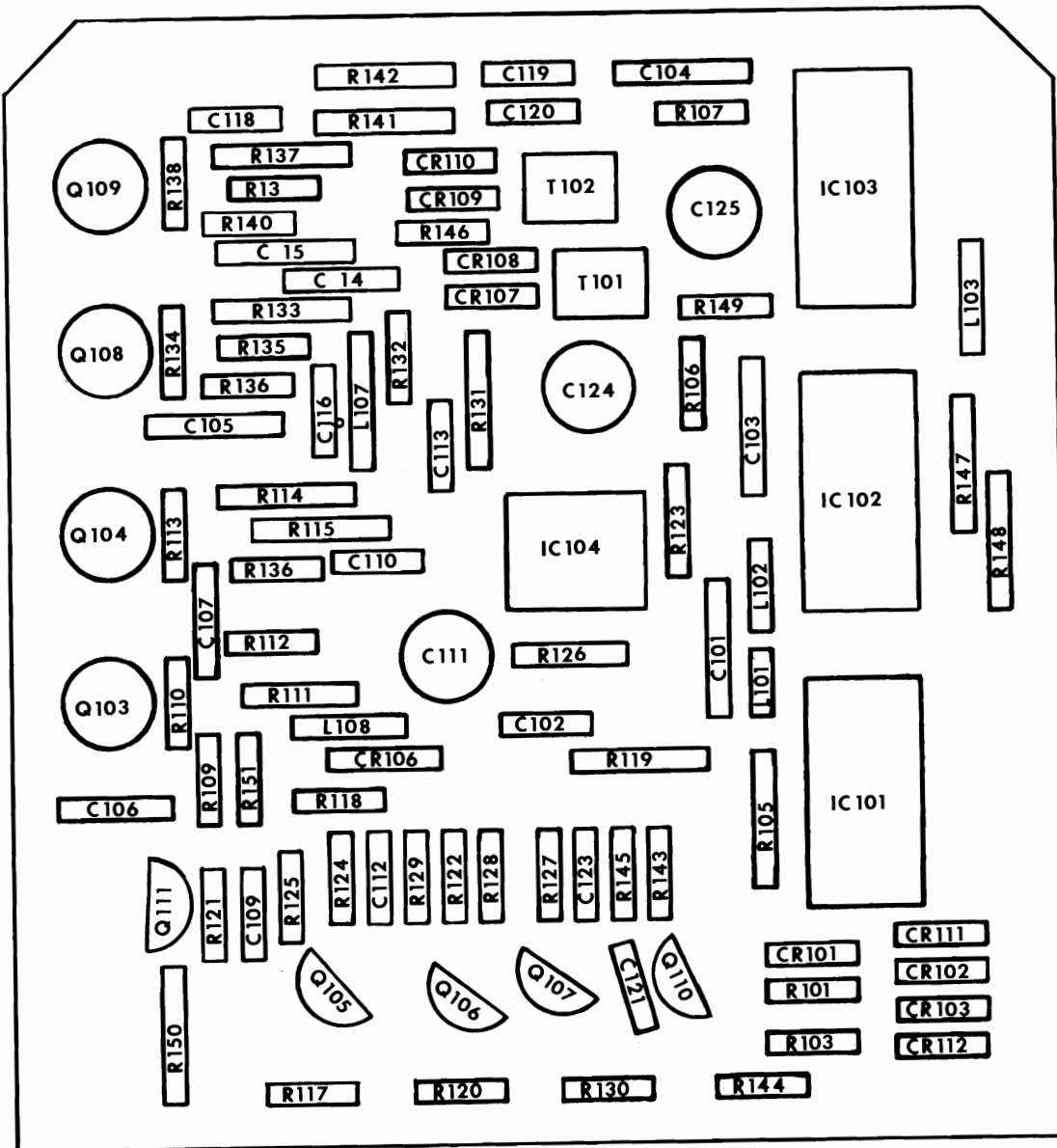

M106  
DLX. HAR. MARKER

REV B

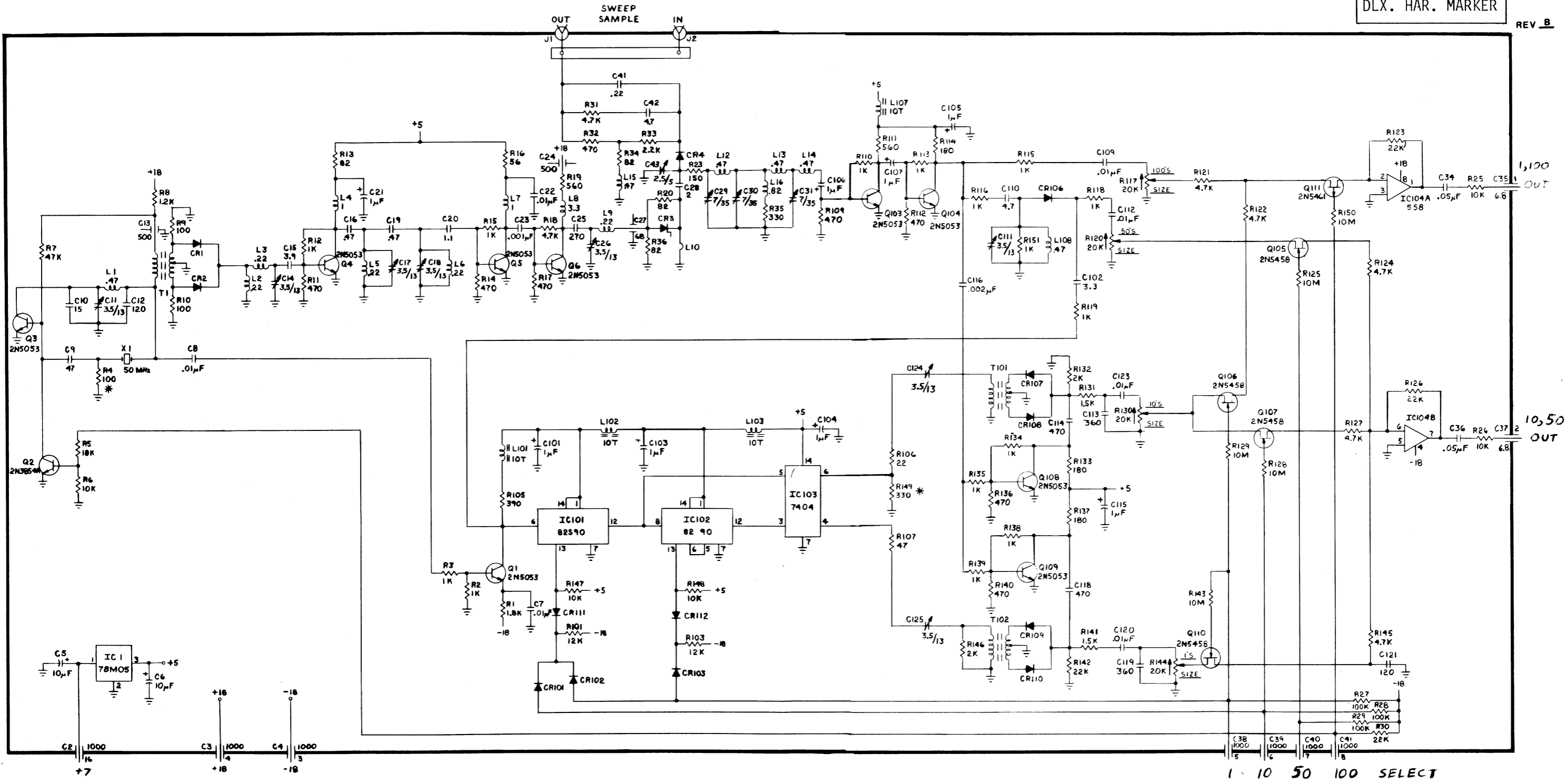

1 10 50 100 SELECT

MANUAL CHANGES - MODEL 2002A

- Pg 5-13 1500 MHz crossover adj. is R63, not R64.
- M131 R17 and R45 are now CTS, 363T105B, Wavetek P/N 4610-00-3105.
- M104A R10 and R29 are now 100 kohm, Wavetek P/N 4700-15-1003.  
R30 and R41 (see schematic details) are 1 Mohm potentiometers, CTS, 363S105B, Wavetek P/N 4610-00-1105.

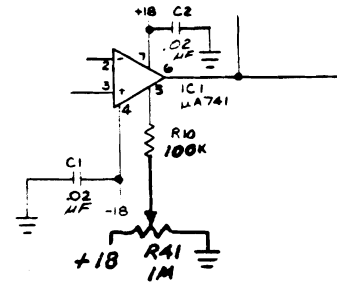
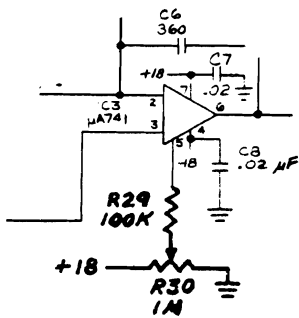

Also, add L1 (Wavetek P/N 1810-05-0004) to the Parts List.

Page 5-14 Figures 5-20 and 5-21 are reversed. Figure 5-20 (M104A Adjustments) is updated as shown. (NOTE: RF Bal and S.S. Bal are factory adjustments.)

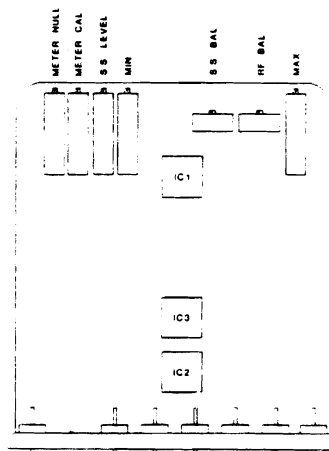

M109 Add 10K resistor R43 (Wavetek P/N 4700-15-1002) from pin 2 of IC1 to ground.

M106 Add CR112 (1N4148, Wavetek P/N 4807-01-0914) as shown.

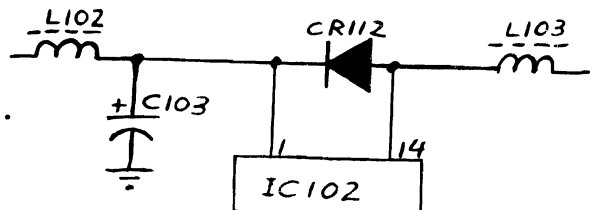

4/2/81