

EMERSON RADIO & PHONO. CORP. Chassis AY

MODELS AY194, AY195

MODEL BD197

Chassis BD Schematics

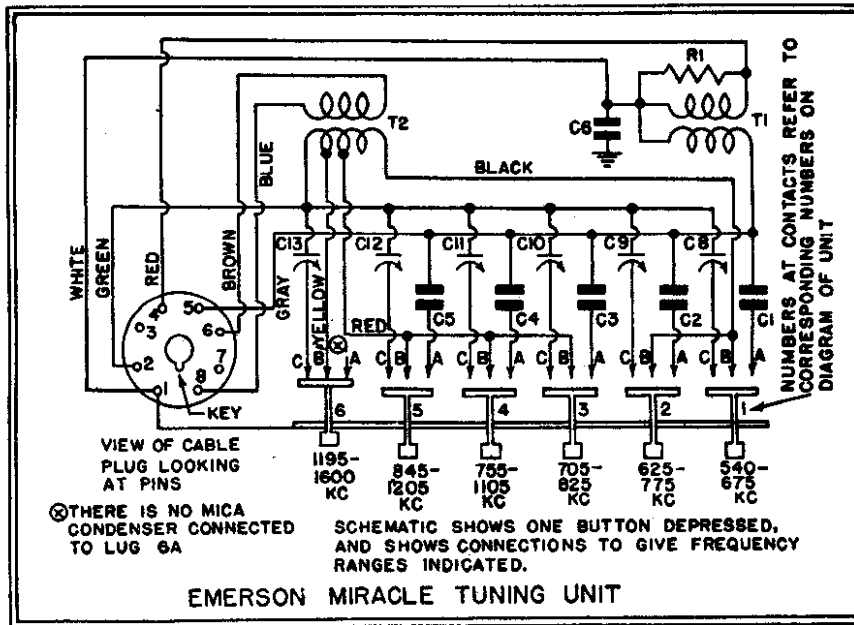

Schematic No. 3

Tube Data

The tube complement is as follows:

- 1-6A7, pentagrid oscillator-modulator.
- 1-6D6, first i-f amplifier.
- 1-6Q7, diode detector, a-f amplifier, a.v.c.
- 1-25L6, beam power output.
- 1-25Z5, dual half-wave rectifier.
- 1-3CR-241, ballast tube (R13 on schematic).

All octal-base tubes may be replaced with either metal or equivalent octal-base glass tubes.

