

CDP-CX300/CX350/CX691

SERVICE MANUAL

US Model
CDP-CX300/CX350/CX691
Canadian Model
CDP-CX300/CX350
AEP Model
UK Model
Australian Model
CDP-CX350



Photo; CDP-CX350

Model Name Using Similar Mechanism	NEW
CD Mechanism Type	CDM54-KIBD35E
Base Unit Type	KSM-213BFN/M-NP
Optical Pick-up Type	KSS-213BFN

SPECIFICATIONS

Compact disc player

Laser	Semiconductor laser ($\lambda = 780 \text{ nm}$) Emission duration: continuous
Laser output	Max 44.6 μW * * This output is the value measured at a distance of 200 mm from the objective lens surface on the Optical Pick-up block with 7 mm aperture.
Frequency response	20 Hz to 20 kHz $\pm 0.5 \text{ dB}$
Signal-to-noise ratio	CDP-CX350: More than 108 dB CDP-CX300/CX691: More than 107 dB
Dynamic range	More than 93 dB
Harmonic distortion	Less than 0.0045 %
Channel separation	More than 100 dB

Outputs

	Jack type	Maximum output level	Load impedance
LINE OUT	Phono jacks	2 V (at 50 kilohms)	Over 10 kilohms
DIGITAL OUT (OPTICAL)	Optical output connector	-18 dBm	Wave length: 660 nm

General

Power requirements

Where purchased	Power requirements
USA	120 V AC, 60 Hz
Australia	240 V AC, 50/60 Hz

Power consumption CDP-CX350: 13 W

Dimensions (approx.) (w/h/d) 430 \times 189 \times 484 mm (17 \times 7 1/2 \times 19 in.) incl. projecting parts

Mass (approx.) CDP-CX350: 8.5 kg (18 lbs 12 oz)

Supplied accessories

- Audio cord (1)
- CD booklet holders (3) and label (1)
- Remote commander (remote) (1) (CDP-CX300/CX350 only)
- Size AA (LR6) batteries (3)
- Size AA (NS) batteries (2) (CDP-CX300 only)

Design and specifications are subject to change without notice.

COMPACT DISC PLAYER

SONY®



Laser component in this product is capable of emitting radiation exceeding the limit for Class 1.

CLASS 1 LASER PRODUCT
LUOKAN 1 LASERLAITE
KLASS 1 LASERAPPARAT

This appliance is classified as a CLASS 1 LASER product. The CLASS 1 LASER PRODUCT MARKING is located on the rear exterior.

CAUTION : INVISIBLE LASER RADIATION WHEN OPEN AND INTERLOCKS DEFEATED. AVOID EXPOSURE TO BEAM.
ADVARSEL : USYNLIG LASERSTRÅLING VED ÅBNING NÅR SIKKERHEDSAFBRYDERE ER UDE AF FUNKTION UNDGÅ UDSÆTTELSE FOR STRÅLING.
VORSICHT : UNSICHTBARE LASERSTRALUNG, WENN ABDECKUNG GEÖFFNET UND SICHERHEITSVERRIEGELUNG ÜBERBRÜCKT, NICHT DEM STRAHL AUSSETZEN.
VARO! : AVATTAESSA JA SUOJALUKITUS OHITETTASSA OLET ALT-TINA NÄKYMÄTTÖMÄLLE LASERSÄTEYILLE, ÄLÄ KATSO SÄTEESEEN.
VARNING : OSYNLIG LASERSTRÅLING NÅR DENNA DEL ÄR ÖPPNAD OCH SPÄRREN ÄR URKOPPLAD, BETRÄKTA EJ STRÅLEN.
ADVERSEL : USYING LASERSTRÅLING NÅR DEKSEL ÅPNES OG SIKKERHEDSLÅS BRYTES, UNNGÅ EKSPONERING FOR STRÅLEN.
VIGYÁZAT! : A BURKOLAT NYITÁSAKOR LÁTHATATIAN LÉZERSUGÁRVESZÉLY! KERÜLJE A BESUGÁRZÁST!

The following caution label is located inside of the unit.

CAUTION

Use of controls or adjustments or performance of procedures other than those specified herein may result in hazardous radiation exposure.

Notes on chip component replacement

- Never reuse a disconnected chip component.
- Notice that the minus side of a tantalum capacitor may be damaged by heat.

Flexible Circuit Board Repairing

- Keep the temperature of soldering iron around 270°C during repairing.
- Do not touch the soldering iron on the same conductor of the circuit board (within 3 times).
- Be careful not to apply force on the conductor when soldering or unsoldering.

SAFETY-RELATED COMPONENT WARNING !!

COMPONENTS IDENTIFIED BY MARK \triangle OR DOTTED LINE WITH MARK \triangle ON THE SCHEMATIC DIAGRAMS AND IN THE PARTS LIST ARE CRITICAL TO SAFE OPERATION. REPLACE THESE COMPONENTS WITH SONY PARTS WHOSE PART NUMBERS APPEAR AS SHOWN IN THIS MANUAL OR IN SUPPLEMENTS PUBLISHED BY SONY.

ATTENTION AU COMPOSANT AYANT RAPPORT À LA SÉCURITÉ!!

LES COMPOSANTS IDENTIFIÉS PAR UNE MARQUE \triangle SUR LES DIAGRAMMES SCHÉMATIQUES ET LA LISTE DES PIÈCES SONT CRITIQUES POUR LA SÉCURITÉ DE FONCTIONNEMENT. NE REMPLACER CES COMPOSANTS QUE PAR DES PIÈCES SONY DONT LES NUMÉROS SONT DONNÉS DANS CE MANUEL OU DANS LES SUPPLÉMENTS PUBLIÉS PAR SONY.

SAFETY CHECK-OUT

After correcting the original service problem, perform the following safety checks before releasing the set to the customer: Check the antenna terminals, metal trim, “metallized” knobs, screws, and all other exposed metal parts for AC leakage. Check leakage as described below.

LEAKAGE

The AC leakage from any exposed metal part to earth Ground and from all exposed metal parts to any exposed metal part having a return to chassis, must not exceed 0.5 mA (500 microamperes). Leakage current can be measured by any one of three methods.

1. A commercial leakage tester, such as the Simpson 229 or RCA WT-540A. Follow the manufacturers’ instructions to use these instruments.
2. A battery-operated AC milliammeter. The Data Precision 245 digital multimeter is suitable for this job.
3. Measuring the voltage drop across a resistor by means of a VOM or battery-operated AC voltmeter. The “limit” indication is 0.75 V, so analog meters must have an accurate low-voltage scale. The Simpson 250 and Sanwa SH-63Trd are examples of a passive VOM that is suitable. Nearly all battery operated digital multimeters that have a 2V AC range are suitable. (See Fig. A)

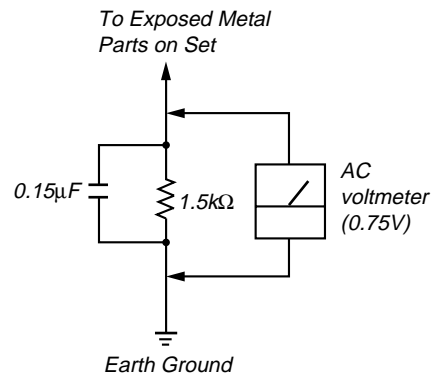
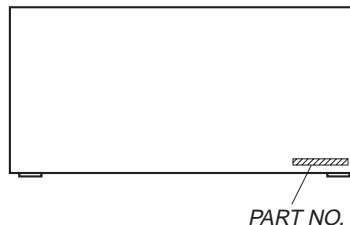

Fig. A. Using an AC voltmeter to check AC leakage.

MODEL IDENTIFICATION — BACK PANEL —



PARTS No.	MODEL
4-215-964-0□	CX300 : US
4-215-964-1□	CX300 : CND
4-215-964-2□	CX350 : US
4-215-964-3□	CX350 : CND
4-215-964-4□	CX350 : AEP, UK
4-215-964-5□	CX350 : AUS
4-215-964-7□	CX691 : US

- Abbreviation
CND : Canadian model
AUS : Australian model

SECTION 1 SERVICING NOTE

TABLE OF CONTENTS

1. SERVICING NOTE	3
2. GENERAL	6
3. DISASSEMBLY	
3-1. Front Panel Assembly	7
3-2. Table (300) Assembly	7
3-3. Base (Door, Gear) Assembly	8
3-4. Pop-up Assembly	8
3-5. Mechanism Deck	9
3-6. Base Unit	9
4. SERVICE MODE	10
5. TEST MODE	14
5-1. ADJ Mode	14
5-2. Key and Display Check Mode	14
6. ADJUSTMENTS	
6-1. Mechanical Adjustments	15
6-2. Electrical Adjustment	17
7. DIAGRAMS	
7-1. Circuit Boards Location	20
7-2. Block Diagrams	
• BD Section	21
• Main Section	23
7-3. Schematic Diagram – BD Section –	27
7-4. Printed Wiring Board – BD Section –	29
7-5. Printed Wiring Board – Main Section –	31
7-6. Schematic Diagram – Main (1/2) Section –	33
7-7. Schematic Diagram – Main (2/2) Section –	35
7-8. Printed Wiring Board – T. Sens Section –	37
7-9. Printed Wiring Board – T. Sens (In) Section –	37
7-10. Printed Wiring Board – D. Sens (Out) Section –	38
7-11. Schematic Diagram – Sensor Section –	38
7-12. Schematic Diagram – Display Section –	39
7-13. Printed Wiring Board – Display Section –	41
7-14. Schematic Diagram – Jog Section –	43
7-15. Printed Wiring Board – Jog Section –	44
7-16. Schematic Diagram – Power Section –	47
7-17. Printed Wiring Board – Power Section –	48
7-18. Schematic Diagram – Jack Section –	49
7-19. Printed Wiring Board – Jack Section –	50
7-20. Schematic Diagram – Sensor/Motor Section –	53
7-21. Printed Wiring Board – Sensor/Motor Section –	54
7-22. IC Block Diagrams	55
7-23. IC Pin Functions	58
8. EXPLODED VIEWS	
8-1. Case Section	60
8-2. Chassis Section	61
8-3. Front Panel Section	62
8-4. Mechanism Section 1 (CDM54-K1BD35E)	63
8-5. Mechanism Section 2 (CDM54-K1BD35E)	64
8-6. Mechanism Section 3 (CDM54-K1BD35E)	65
8-7. Optical Pick-up Section (KSM-213BFN/M-NP)	66
9. ELECTRICAL PARTS LIST	67

NOTES ON HANDLING THE OPTICAL PICK-UP BLOCK OR BASE UNIT

The laser diode in the optical pick-up block may suffer electrostatic break-down because of the potential difference generated by the charged electrostatic load, etc. on clothing and the human body. During repair, pay attention to electrostatic break-down and also use the procedure in the printed matter which is included in the repair parts.

The flexible board is easily damaged and should be handled with care.

NOTES ON LASER DIODE EMISSION CHECK

The laser beam on this model is concentrated so as to be focused on the disc reflective surface by the objective lens in the optical pick-up block. Therefore, when checking the laser diode emission, observe from more than 30 cm away from the objective lens.

The emission check enables continuous checking of the S curve.

LASER DIODE AND FOCUS SEARCH OPERATION CHECK

Carry out the “S curve check” in “CD section adjustment” and check that the S curve waveform is output three times.

CD-TEXT TEST DISC

This unit is able to display the TEXT data (character information) written in the CD on its fluorescent indicator tube.

The CD-TEXT TEST DISC (TGCS-313:J-2501-126-A) is used for checking the display.

To check, perform the following procedure.

Checking Method:

1. Turn ON the power, set the disc on the disc table with the side labeled as “test disc” as the right side, close the front cover, and chuck the disc.
2. The following will be displayed on the fluorescent indicator tube. (The display switches each time the **TIME/TEXT** button is pressed.)
Display : CD TEXT TEST DISC (Album Title)
3. Press the **▶** button and play back the disc.
4. The following will be displayed on the fluorescent indicator tube. (If nothing is displayed, press the **TIME/TEXT** button.)
Display : 1kHz/0 dB/ L&R
5. Rotate **◀▶** knob to switch the track. The text data of each track will be displayed.
For details of the displayed contents for each track, refer to “Table 1 : CD-TEXT TEST DISC Text Data Contents” and “Table 2 : CD-TEXT TEST DISC Recorded Contents and Display”.

Restrictions in CD-TEXT Display

In this unit, some special characters will not be displayed properly. These will be displayed as a space or a character resembling it. For details, refer to “Table 2 : CD-TEXT DISC Recorded Contents and Display”.

Table 1 : CD-TEXT TEST DISC Text Data Contents (TRACKS No. 1 to 41:Normal Characters)

TRACK No.	Displayed Contents	TRACK No.	Displayed Contents
1	1kHz/0dB/L&R	22	1kHz/-90dB/L&R
2	20Hz/0dB/L&R	23	Infinity Zero w/o emphasis//L&R
3	40Hz/0dB/L&R	24	Infinity Zero with emphasis//L&R
4	100Hz/0dB/L&R	25	400Hz+7kHz(4:1)/0dB/L&R
5	200Hz/0dB/L&R	26	400Hz+7kHz(4:1)/-10dB/L&R
6	500Hz/0dB/L&R	27	19kHz+20kHz(1:1)/0dB/L&R
7	1kHz/0dB/L&R	28	19kHz+20kHz(1:1)/-10dB/L&R
8	5kHz/0dB/L&R	29	100Hz/0dB/L*
9	7kHz/0dB/L&R	30	1kHz/0dB/L*
10	10kHz/0dB/L&R	31	10kHz/0dB/L*
11	16kHz/0dB/L&R	32	20kHz/0dB/L*
12	18kHz/0dB/L&R	33	100Hz/0dB/R*
13	20kHz/0dB/L&R	34	1kHz/0dB/R*
14	1kHz/0dB/L&R	35	10kHz/0dB/R*
15	1kHz/-1dB/L&R	36	20kHz/0dB/R*
16	1kHz/-3dB/L&R	37	100Hz Squer Wave//L&R
17	1kHz/-6dB/L&R	38	1kHz Squer Wave//L&R
18	1kHz/-10dB/L&R	39	1kHz w/emphasis/-0.37dB/L&R
19	1kHz/-20dB/L&R	40	5kHz w/emphasis/-4.53dB/L&R
20	1kHz/-60dB/L&R	41	16kHz w/emphasis/-9.04dB/L&R
21	1kHz/-80dB/L&R		

NOTE : The contents of Track No. 1 to 41 are the same as those of the current TEST DISC-their titles are displayed.

Table 2: CD-TEXT TEST DISC Recorded Contents and Display
(In this unit, some special characters cannot be displayed. This is no a fault.)

TRACK No.	Recorded contents	Display
42	! " # \$ % & ' (21h to 27h) 1kHz 0dB L&R	← All the same
43	() * + , - . / (28h to 2Fh)	← All the same
44	0 1 2 3 4 5 6 7 (30h to 37h)	← All the same
45	8 9 : ; < = > ? (38h to 3Fh)	← All the same
46	@ A B C D E F G (40h to 47h)	← All the same
47	H I J K L M N O (48h to 4Fh)	← All the same
48	P Q R S T U V W (50h to 57h)	← All the same
49	X Y Z [\] ^ _ (58h to 5Fh)	X Y Z [\] ^ _ (58....
50	` a b c d e f g (60h to 67h)	← All the same
51	h i j k l m n o (68h to 6Fh)	← All the same
52	p q r s t u v w (70h to 77h)	← All the same
53	x y z { } ~ ■ (78h to 7Fh)	x y z { } ~ (78....
54	■ i ç £ ¤ ¥ ¦ § (A0h to A7h) 8859-1	i ç £ ¤ ¥ ¦ § (A0.... ■ is not displayed
55	♪ ©ª « ¬ ® ¯ (A8h to AFh)	♪ (A8.... ©ª « ¬ ® ¯ are not displayed
56	· ± ² ³ ´ µ ¶ • (B0h to B7h)	´ µ • (B0.... · ± ² ³ ¶ are not displayed
57	† ° » ¼ ½ ¾ ¿ (B8h to BFh)	† ¿ (B8.... ° » ¼ ½ ¾ are not displayed
58	À Á Â Ã Ä Å Æ Ç (C0h to C7h)	← All the same
59	È É Ê Ë Ì Í Î Ï (C8h to CFh)	← All the same
60	Ð Ñ Ò Ó Ô Õ Ö × (D0h to D7h)	← All the same
61	Ø Ù Ú Û Ü Ý Þ ß (D8h to DFh)	Ø Ù Ú Û Ü Ý Þ ß (D8....
62	à á â ã ä å æ ç (E0h to E7h)	← All the same
63	è é ê ë ì í î ï (E8h to FFh)	← All the same
64	ð ñ ò ó ô õ ö ÷ (F0h to F7h)	ð ñ ò ó ô õ ö ÷ (F0....
65	ø ù ú û ü ý þ ÿ (F8h to FFh)	← All the same
66	No.66	← All the same
67	No.67	← All the same
to	to	to
99	No.99	← All the same

SECTION 2 GENERAL

Front Panel

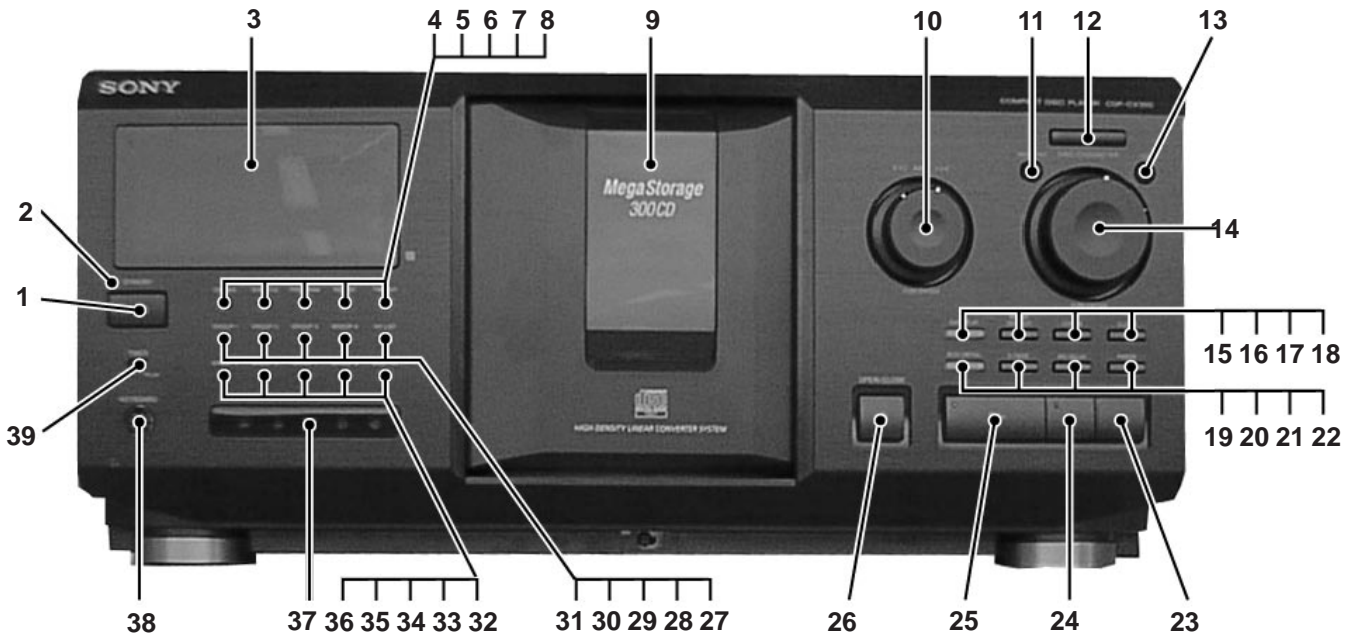

Photo: CDP-CX350

LOCATION OF PARTS AND CONTROLS

- | | | | |
|----|---|----|---------------------------------|
| 1 | I/⏻ (power) button | 21 | NO DELAY button |
| 2 | STANDBY indicator | 22 | FADER button |
| 3 | Display window | 23 | ■ (stop)/DISC EJECT button |
| 4 | CONTINUE button | 24 | ▬▬ (pause) button and indicator |
| 5 | SHUFFLE button | 25 | ▷ (play) button and indicator |
| 6 | PROGRAM button | 26 | ⌘ OPEN/CLOSE button |
| 7 | REPEAT button | 27 | HIT LIST button and indicator |
| 8 | TIME/TEXT button | 28 | GROUP 4 button and indicator |
| 9 | Front cover | 29 | GROUP 3 button and indicator |
| 10 | ◀◀ AMS ▶▶/PUSH ENTER knob and button | 30 | GROUP 2 button and indicator |
| 11 | MENU/NO button | 31 | GROUP 1 button and indicator |
| 12 | +100 button | 32 | GROUP FILE button |
| 13 | YES button | 33 | GROUP 8 button and indicator |
| 14 | DISC/CHARACTER/PUSH ENTER knob and button | 34 | GROUP 7 button and indicator |
| 15 | EASY PLAY button and indicator | 35 | GROUP 6 button and indicator |
| 16 | MEMO/SEARCH button | 36 | GROUP 5 button and indicator |
| 17 | CHECK button | 37 | IR Repeater window (CDP-CX350) |
| 18 | CLEAR button | 38 | KEYBOARD jack |
| 19 | MEGA CONTROL button and indicator | 39 | TIMER OFF/PLAY switch |
| 20 | X-FADE button | | |

* AMS is abbreviation for Automatic Music Sensor.

SECTION 3 DISASSEMBLY

Note : Follow the disassembly procedure in the numerical order given.

3-1. FRONT PANEL ASSEMBLY

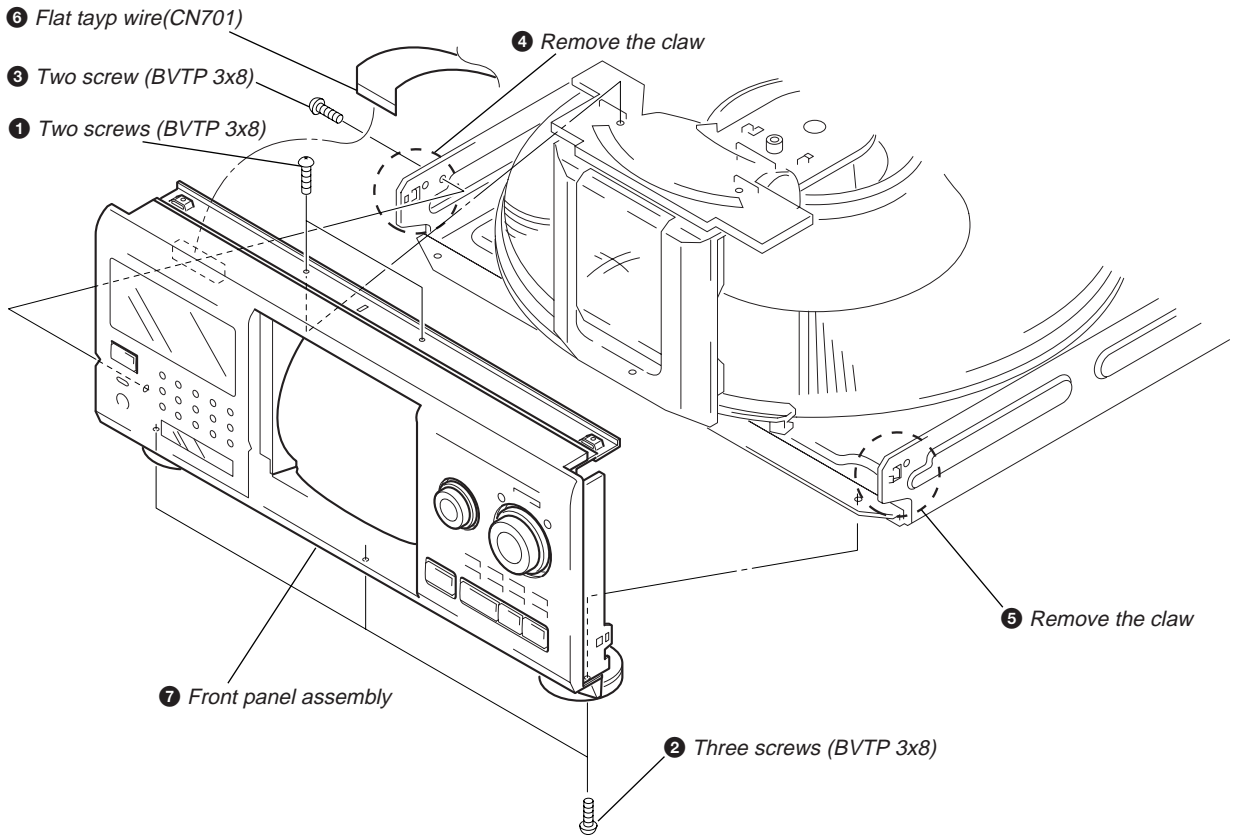

3-2. TABLE (300) ASSEMBLY

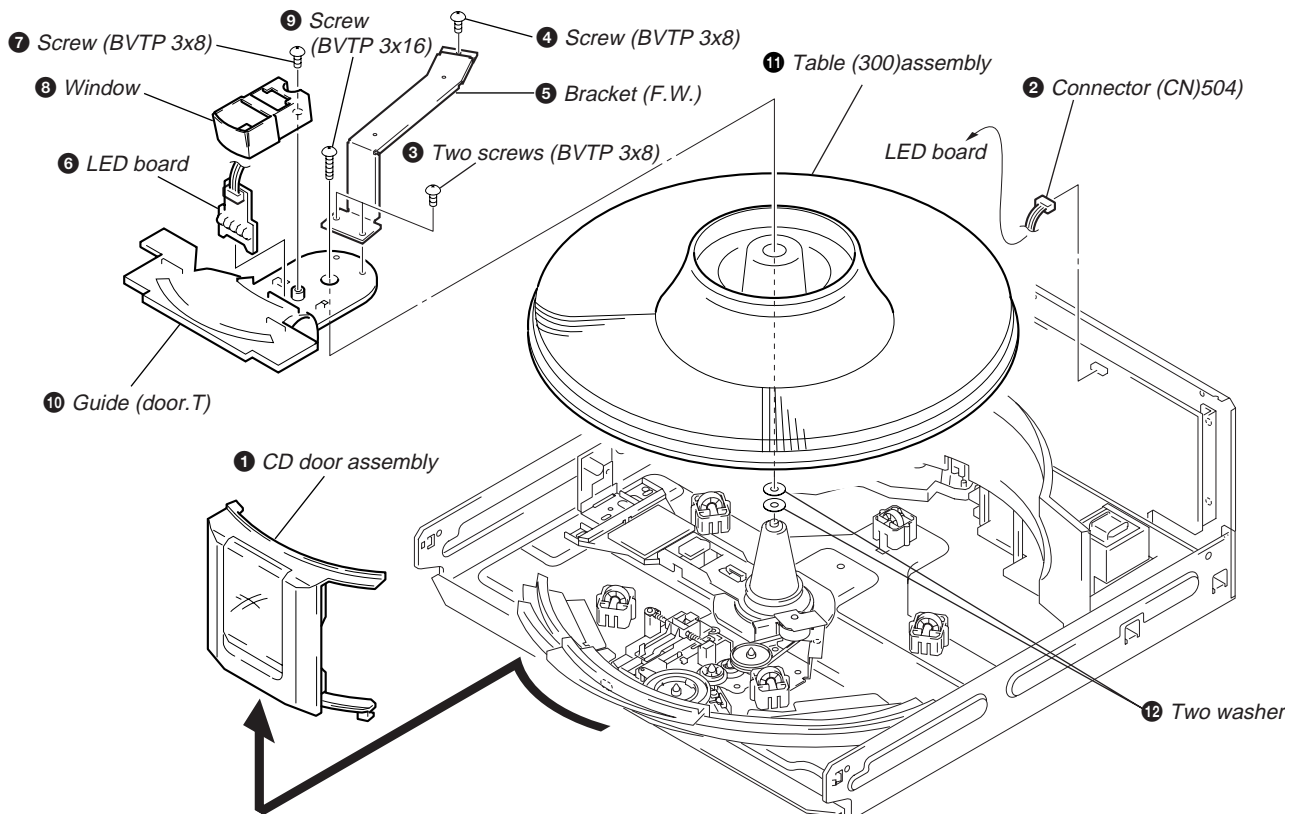

3-3. BASE (DOOR, GEAR) ASSEMBLY

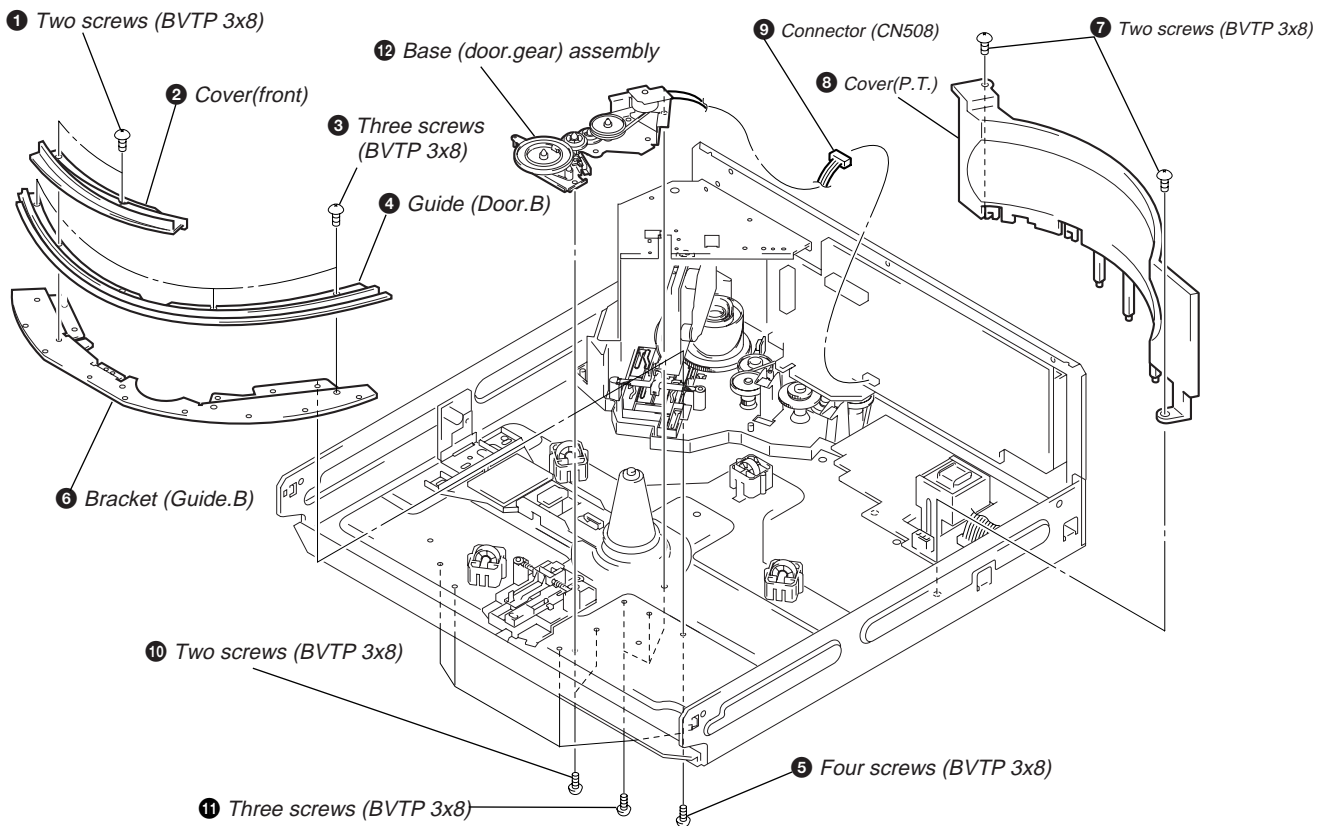

3-4. POP-UP ASSEMBLY

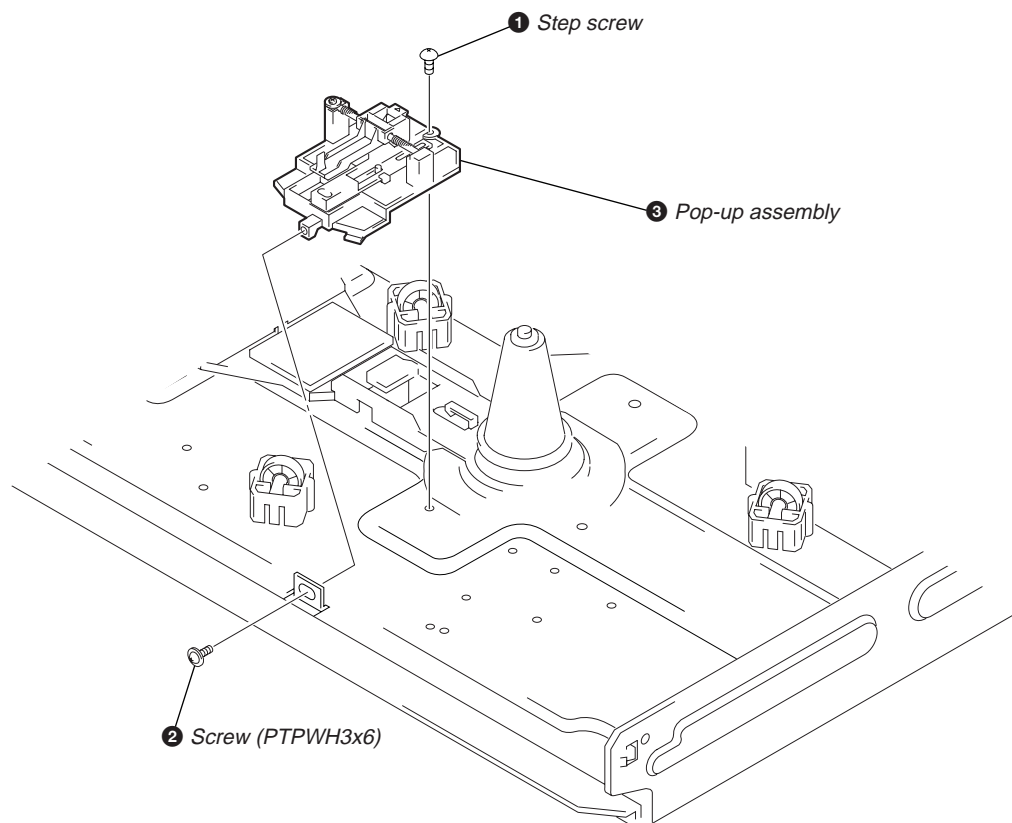

3-5. BACK PANEL ASSEMBLY

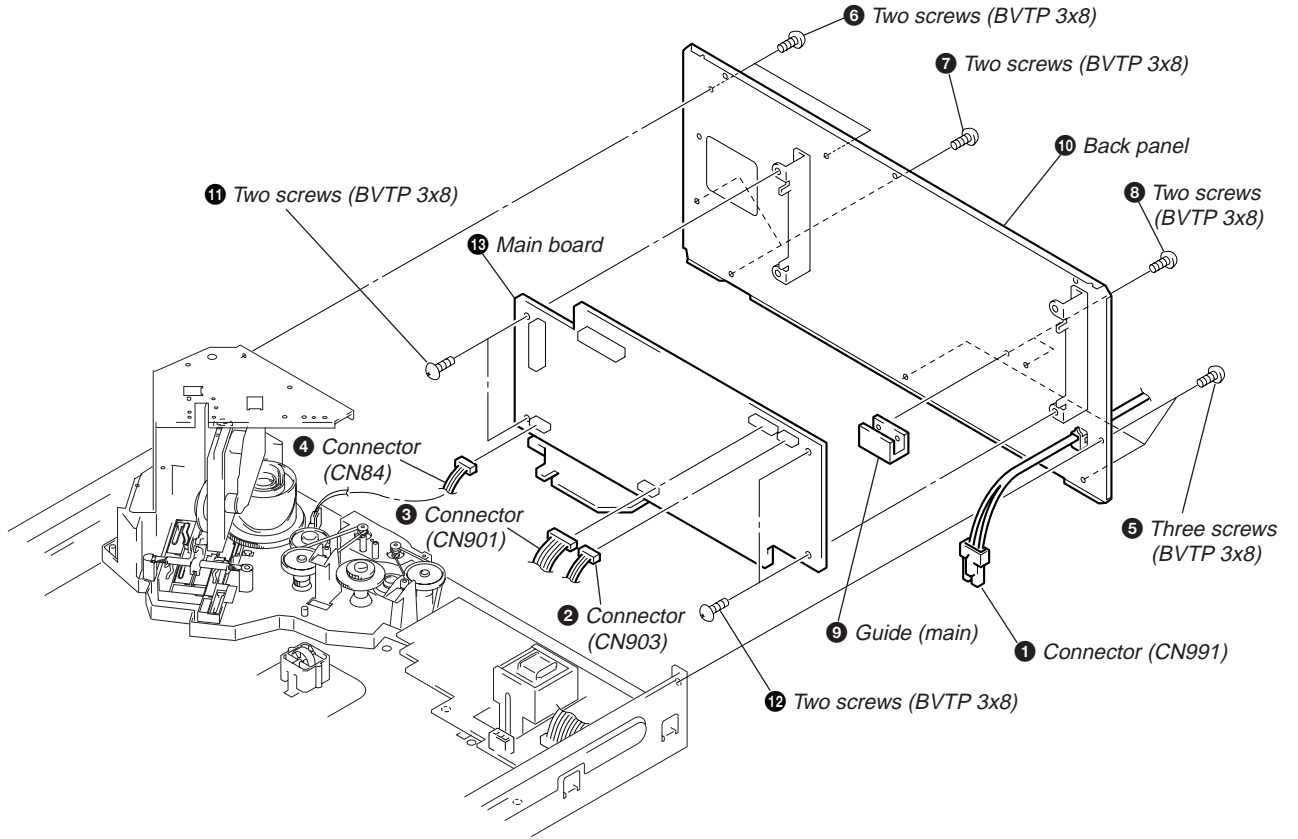

3-6. CDM ASSEMBLY

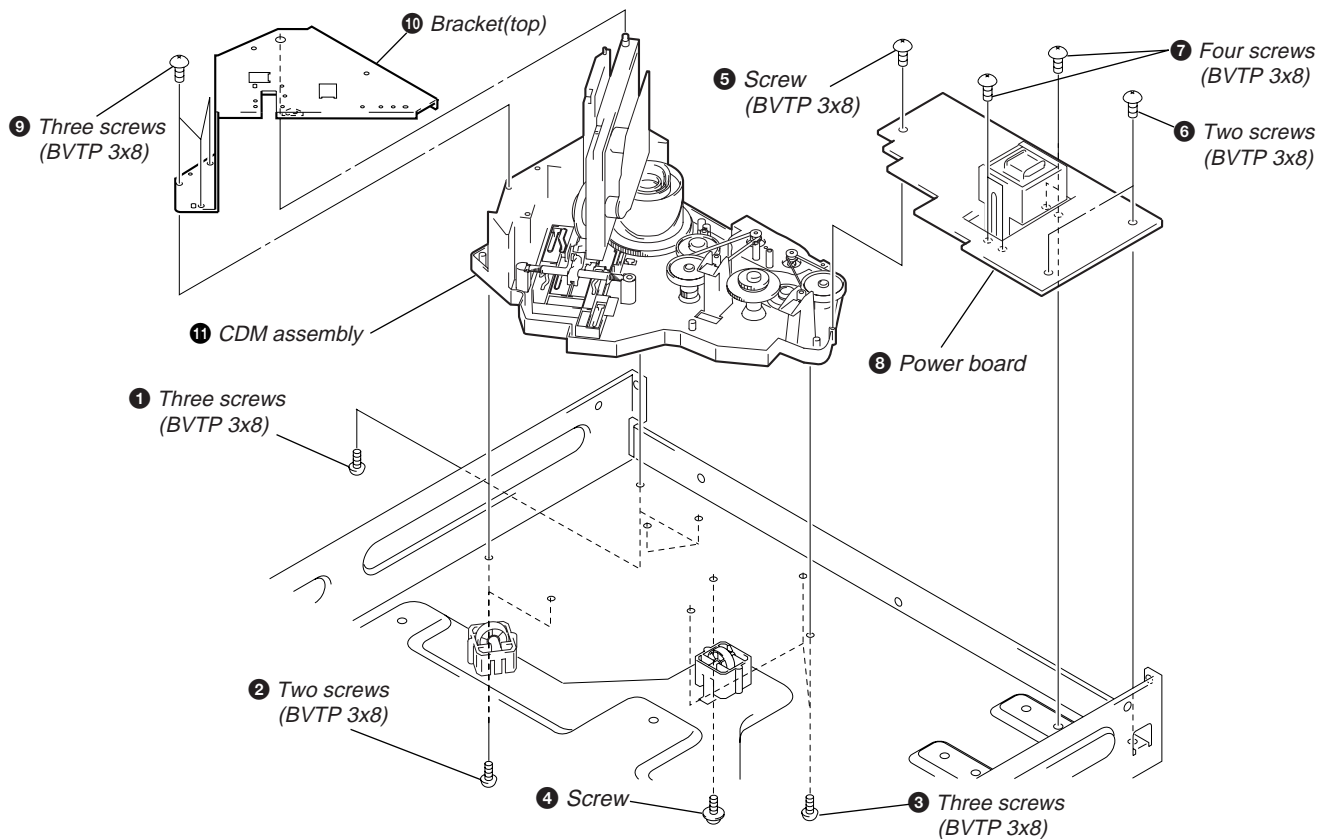

SECTION 4 SERVICE MODE

SPECIAL FUNCTION

This unit is provided with several service modes. Details are shown in the following table.

Mode name	Power supply state	Button operation	Remarks
ALL ERASE	OFF	[CLEAR] + [0]	Note 1
AGING MODE	ON	[GROUP 1] + [△ OPEN/CLOSE] + [+100]	
LOADING AGING MODE	ON	[GROUP 2] + [△ OPEN/CLOSE] + [+100]	
TABLE AGING MODE	ON	[GROUP 3] + [△ OPEN/CLOSE] + [+100]	
DOOR POP UP AGING MODE	ON	[GROUP 4] + [△ OPEN/CLOSE] + [+100]	
TABLE LOTATION MODE	ON	[GROUP 5] + [△ OPEN/CLOSE] + [+100]	Used in adjustment
TITLE MEMO SHIFT MODE	ON	[GROUP 7] + [△ OPEN/CLOSE] + [+100]	
MODEL NAME DISPLAY	ON	[GROUP 1] + [▷] + [+100]	
MICROPROCESSOR VERSION DISPLAY	ON	[GROUP 2] + [▷] + [+100]	
ALL LIT MODE	ON	[GROUP 3] + [▷] + [+100]	
MECHANISM ADJUSTMENT MODE	ON	[GROUP 4] + [▷] + [+100]	
SHIPMENT MODE	ON	[GROUP 5] + [▷] + [+100]	Note 1
TITLE MEMO RECORDING CHECK MODE	ON	[GROUP 6] + [▷] + [+100]	Note 1

Note 1

Do not execute unless with a proper reason, otherwise the memory of the title memo recorded by the customer will be erased. The title memo recording check mode is not required for servicing. Do not execute.

ALL ERASE

This mode is used for clearing information such as the title memo. Do not execute if information such as the title memo is not to be erased.

Procedure:

While pressing the [CLEAR] button with the power OFF, press the [I/⏻] button and turn on the power.

The fluorescent display tube displays "ALL ERASE" and all memories will be cleared.

AGING MODE

- Mode which repeatedly changes and plays back discs automatically in the unit.
 - It will repeat aging as long as no errors occur.
 - If an error occurs during aging, it will stop all servos, motors, etc. instantaneously, display the error number, and stop operations. However, the stopping conditions differ according to whether the unit is equipped with the "self-protection function during errors" described later.
- The function serves to maintain the state of the unit when errors occur.

Sequence of Aging Mode

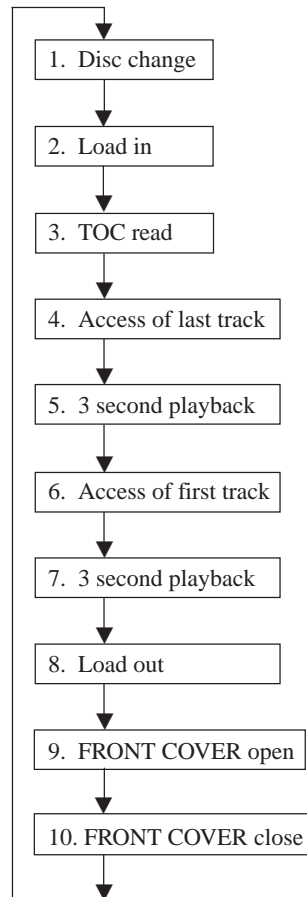

Order of Disc Change

(1 cycle takes 3 minutes)

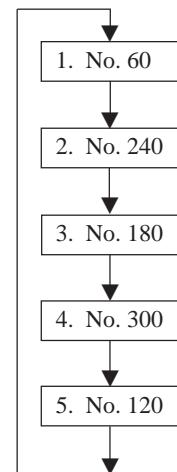

Special Aging Mode Functions

The aging mode is provided with the following convenient functions

- Disc setting mode (*1)
- Selection of presence of protection function during error (*2)
- Count function of aging cycle (*3)

***1 Disc setting mode:**

5 discs are set before setting the aging mode. This mode makes the setting of these discs more easy.

***2 Self protection function during errors:**

Function which voluntarily corrects errors which occur during normal operations by retries.

If this function is not provided, all operations will be stopped without retiring. It is suitable for checking errors with low reproducibility.

If this function is provided, and errors can be corrected by retries, aging will be continued without stopping.

***3 Aging cycle count function:**

Functions which displays the number of agings carried out on the Fluorescent indicator tube in numbers. One aging cycle consists of five discs.

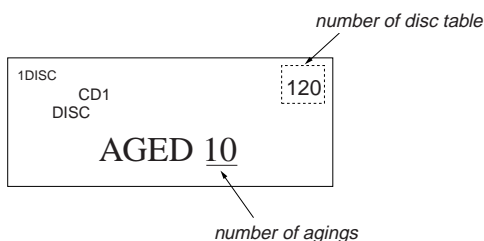

Aging Procedure

1. Turn ON the power of the unit. Press the **OPEN/CLOSE** and open the front cover.
2. Change the **COMMAND MODE** switch (S901) on set to **CD1**.
3. Press the **AGING START** button of the remote commander for aging mode (J-2501-123-A).
4. When the disc set mode is set, the **▶** and **■** LEDs blink.
5. Rotate the **DISC/CHARACTER** dial. The slits (No. 60, 120, 180, 240, 300) for setting the discs will come forward. Insert the discs into these slits. Do not set the discs in other slits.
6. Set whether the self-protection function during errors is equipped with the unit. Press the **REPEAT** button. If "REPEAT" is displayed on the Fluorescent indicator tube, it means the function is provided. If "REPEAT" is not displayed, it means the function is not provided.

Error Display

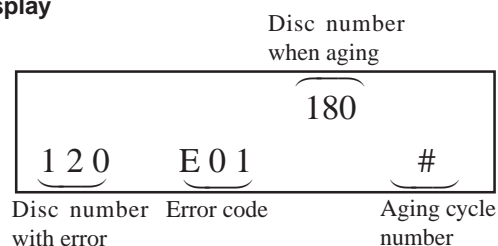

7. Press the **▶** button.
8. The **▶** LED blinks, the aging mode is set, and aging is started.
9. The aging cycle lasts 3 minutes. If errors occur during aging, the error number will be displayed on the Fluorescent indicator tube. (Refer to the following table for the details of the errors.)
10. Aging will be repeated as long as no errors occur.
11. After each aging cycle, the number displayed on the Fluorescent indicator tube will increase.
12. To end aging, disconnect the power cord from the outlet.

NOTE: As an alternative to steps 2 and 3, press the **GROUP 1** button, **OPEN/CLOSE** button, and **+100** button at the same time.

Error code

Code number	Name	Contents
Err 01	DISC sensor check 1	No disc in the specified slit
Err 02	DISC sensor check 2	Disc in other slits
Err 03	Table operation check 1	Table motor current over
Err 04	Table operation check 2	No table sensor input
Err 05	Loading operation check 1	Load in timeover
Err 06	Loading operation check 2	Load out timeover
Err *1	BU related check 1	Access timeover
Err *2	BU related check 2	High speed search NG
Err *3	BU related check 3	Q data read error
Err *4	BU related check 4	BU operation (from focus search to until signal can be read) timeover
Err *5	BU related check 5	GFS monitor error
Err *6	BU related check 6	Focus cannot be imposed by focus search
Err *7	BU related check 7	Auto focus bias adjustment cannot be performed

The * numbers mean the following according to the state of the unit during aging

- 2 : From chucking to end of TOC read
- 3 : From end of TOC read to end of last track playback
- 4 : From end of last track playback to end of first track playback

LOADING AGING MODE

- This mode is used for repeating loading operations continuously.
- Aging will be performed continuously unless an error occurs.
- When an error occurs, the error code will be displayed on the fluorescent indicator tube.

Procedure:

1. Set a disc in the DISC 1 slit.
2. With the power ON, while pressing the **GROUP 2** button and **OPEN/CLOSE** button, press the **+100** button.
3. When the mode is set, both the **▶** and **||** indicators will start to blink.
4. When the **▶** button is pressed, only the **▶** indicator will blink and aging starts.
5. To end the mode, press the **I/O** button or disconnect the power cord from the outlet.

The error codes displayed during operations and when errors occur are the same as the “AGING MODE” described earlier.

TABLE AGING MODE

- This mode is used for rotating the table randomly.
- Aging will be performed continuously unless an error occurs.
- When an error occurs, the error code will be displayed on the fluorescent indicator tube.

Procedure:

1. Set discs in slits 1, 2, 99, 100, and 200.
2. With the power ON, while pressing the **GROUP 3** button and **OPEN/CLOSE** button, press the **+100** button.
3. When the mode is set, both the **▶** and **||** indicators will start to blink.
4. When the **▶** button is pressed, only the **▶** indicator will blink and aging starts.
5. To end the mode, press the **I/O** button or disconnect the power cord from the outlet.

During aging, operations will be carried out sequentially in the order of No. 1, No. 2, No. 100, No. 99, and No. 200 slits.

The error codes displayed during operations and when errors occur are the same as the “AGING MODE” described earlier.

DOOR POP UP AGING MODE

- This mode is used for performing aging of the CD pop up part and door open/close.
It is used for checking if operations are performed normally.

Method:

1. To select a slot to be aged, press the **OPEN/CLOSE** button and rotate the **DISC/CHARACTER** knob with the front door opened to select a number.
2. With the power ON, while pressing the **GROUP 4** button and **OPEN/CLOSE** button, press the **+100** button.
3. When the **▶** button is pressed, aging starts, and door open/close and up/down operations of the pop up part are performed continuously.
4. To end the mode, press the **I/O** button.

If DISC is not selected at step 1, aging will be performed at the 192 slot.

The number of times aging is performed will be displayed on the fluorescent indicator tube during operations.

TABLE ROTATION MODE

- This mode is used for electrical adjustments. Refer to the section on Electrical Adjustments.

TITLE MEMO SHIFT MODE

- This mode is used for writing title memo information recorded in this unit in a different unit.
Use it for transferring disc memo contents written by the customer to the new units when replacing the unit, etc.

Connection:

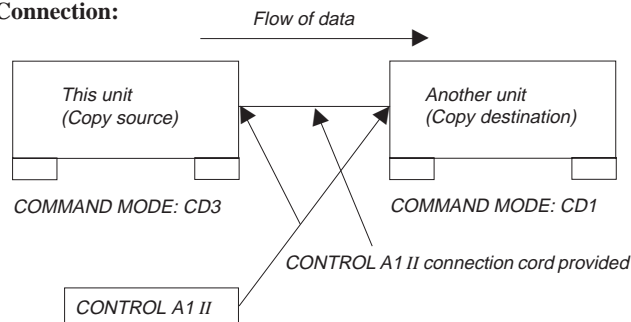

Procedure:

1. Connect two units using the **CONTROL A1 II** connection cord shown in the figure.
2. Set the **COMMAND MODE** switch of the copy source unit to **CD3** and the **COMMAND MODE** switch of the copy destination unit to **CD1**.
3. With the power on, while pressing the **GROUP 7** button and **OPEN/CLOSE** button of the copy destination unit, press the **+100** button.
4. When the data has been transferred, the fluorescent indicator tube displays “complete” for about 1 second.

MODEL NAME DISPLAY

- Model names can be displayed on the fluorescent indicator tube for checking the microprocessor model setting, etc.

Procedure:

With the power ON, while pressing the **GROUP 1** and **▶** buttons, press the **+100** button.
The model name is displayed on the fluorescent indicator tube.

MICROPROCESSOR VERSION DISPLAY

- The microprocessor version can be displayed on the fluorescent indicator tube.

Procedure:

With the power ON, while pressing the **GROUP 2** and **▶** buttons, press the **+100** button.
The microprocessor version is displayed on the fluorescent indicator tube.

ALL LIT MODE

- This mode is used for lighting the whole fluorescent indicator tubes and LEDs.

Procedure:

With the power ON, while pressing the **GROUP 3** and **▶** buttons, press the **+100** button.
Both the fluorescent indicator tubes and LEDs will light up completely.
To end this mode, press the **I/O** mode.

MECHANISM ADJUSTMENT MODE

- This mode is used for mechanism adjustments. Refer to the section on Mechanism Adjustments.

SHIPMENT MODE

- This mode is used for setting the unit to the shipment state. Do not execute it without a proper reason as it erases the memory of the title memo recorded by the customer.

Procedure:

Set the **COMMAND MODE** switch to **CD1** and the **TIMER** switch to **OFF**. Next, with the power ON, while pressing the **GROUP 5** button and **▶** button, press the **+100** button. If the switch state is normal, the model name will be displayed on the fluorescent indicator tube and the unit will set into the shipment mode.

If the various switches are not set to their designated positions, error codes will be displayed on the fluorescent indicator tube.

TITLE MEMO RECORDING CHECK MODE

This mode is not required for servicing. Do not execute without a proper reason.

If executed, the memory of the title memo recorded by the customer will be erased.

SECTION 5 TEST MODE

5-1. ADJ MODE

1. Turn ON the power of the unit, set disc to disc table, and perform chucking.
2. Disconnect the power supply plug from the outlet.
3. To set ADJ mode, connect the test point (ADJ) of the MAIN board to Ground, and connect the power supply plug to the outlet.

In this mode, table rotation and loading operations are not performed because it is taken that the disc has already been chucked.

Note: The same operations are also performed in the following when the test point (ADJ) is connected to Ground after turning on the power.

- Direct search (movement of sledding motor) is not performed during accessing
- Ignored even when GFS becomes L
- Ignored even when the Q data cannot be read
- Focus gain does not decrease

ADJ Mode Special Functions Table (The buttons shown with () function by using the supplied remote commander only)

Button	Function
CONTINUE	Servo average display Displays VC, FE, RF, TE and traverse in hexadecimal numbers
SHUFFLE	Focus bias display Each time this is pressed, the focus bias is switched between 1 and 2 (1) Bias actually set Optimum bias Minimum jitter (2) U:Upper aliasing bias L:Lower aliasing bias
PROGRAM	Auto gain display Displays focus, tracking, sledding in hexadecimal numbers
GROUP 3 (3)	Turns off the tracking and sledding servo
GROUP 8 (8)	Turns on the tracking and sledding servo
CHECK	S-curve observation mode. (Exits this mode when the  button is pressed.)

5-2. KEY AND DISPLAY CHECK MODE

To set this mode, connect the test point (AFADJ) on the MAIN board to Ground, and connect the power supply plug to the outlet.



Note: When this mode is executed, all title memos recorded will be erased.

- When this button is pressed, “line # No. #” will be displayed. However, these will not be displayed for the following special buttons. However, these will not be displayed for the following special buttons.

 (stop) button: FL segment check
(Refer to FL Tube Check Patterns)

 (pause) button: FL grid check
(Refer to FL Tube Check Patterns)

The  LED also lights up simultaneously.

 (play) button: All FL segment and grid will light up.
 LED also lights up simultaneously.

TIMER switch: When the switch position is **PLAY**, the **STANDBY** LED lights up. It goes OFF when set to **OFF**.

Each time this button is pressed, the value of the “Go+ ## keys” increases. Buttons pressed once will not be counted when pressed again.

FL Tube Check Patterns

Segment check

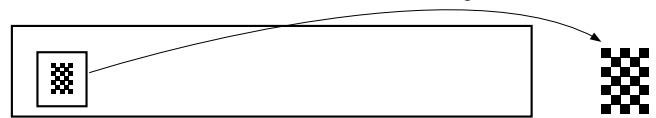

Grid check

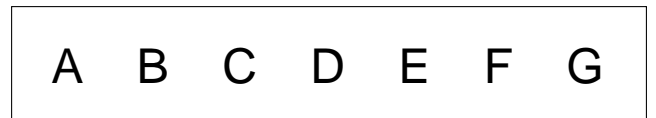

- When the jog dial is rotated to the right, the GROUP LEDs light up in the order of 1→2..8→HIT LIST→EASY PLAY→MEGA CONTROL→1.
- When the jog dial is rotated to the left, the GROUP LEDs light up in the order of 8→7..1→MEGA CONTROL→EASY PLAY→HIT LIST→8.

• Abbreviation

FL: Fluorescent Indicator Tube

[MAIN BOARD] – Component Side –

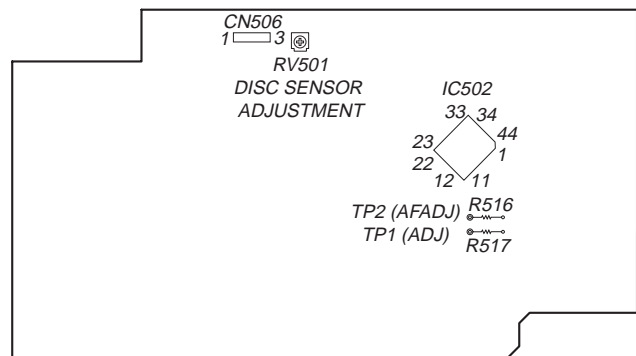

SECTION 6 ADJUSTMENTS

6-1. MECHANICAL ADJUSTMENTS

Pop Up Mechanism Adjustment

1. With the power ON, while pressing the **GROUP 4** and  buttons, press the **+100** button to enter the mechanism adjustment mode.
2. Press the **GROUP 1** button to operate the loading mechanism, and continue pressing until the disc table locks. (Fig-1)
3. Press the **GROUP 2** button to raise the pop up part.
4. Remove the cover (chassis), loosen the adjusting screw, move the screwdriver left and right until the lever (POP UP) does not touch the slit wall, and secure the screw. (Fig-2)

The following buttons have special functions in this mode.

GROUP 1	button: Loading mechanism IN operation
GROUP 5	button: Loading mechanism OUT operation
GROUP 2	button: Pop up part UP operation
GROUP 6	button: Pop up part DOWN operation

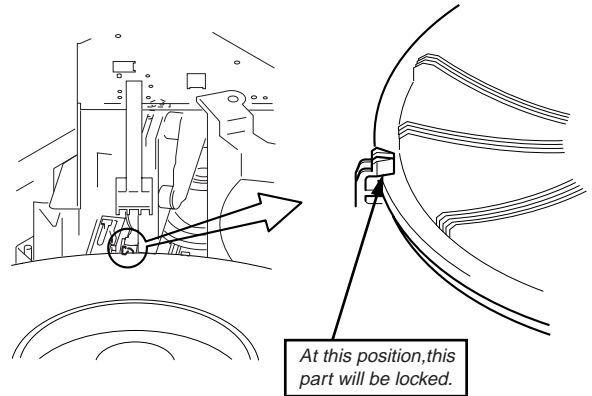
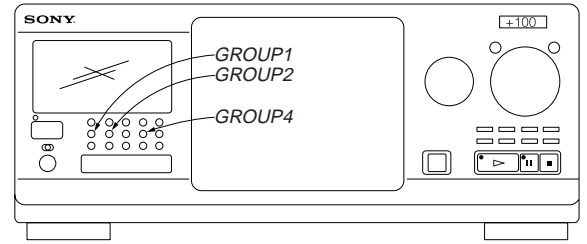

Fig-1

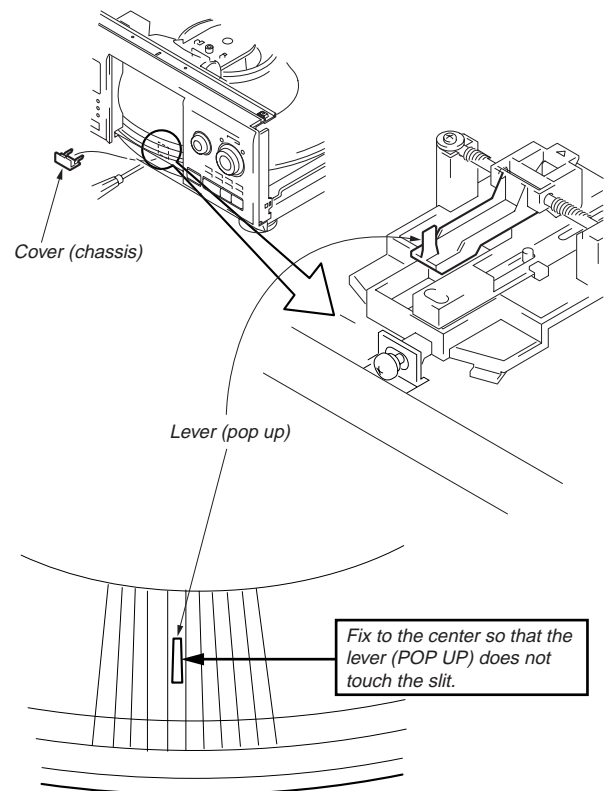

Fig-2

Sensor Adjustment

1. With the power ON, while pressing the **GROUP 4** and **▶** buttons, press the **+100** button to enter the mechanism adjustment mode.
2. Press the **GROUP 1** button to operate the loading mechanism, and continue pressing until the disc table locks. (Fig-3)
3. Loosen the fixing screw, move the holder (TABLE SENSOR) slightly, and when the LED (green) of the **PLAY** button switches to the LED (orange) of the **PAUSE** button (or vice versa), secure the holder (TABLE SENSOR). (Fig-4)
4. Moving the disc table right and left with a hand after the screw is fixed, the table will move by the play of a disc table. If the LEDs light up alternately, the adjustment will be performed correctly. (Fig-4)

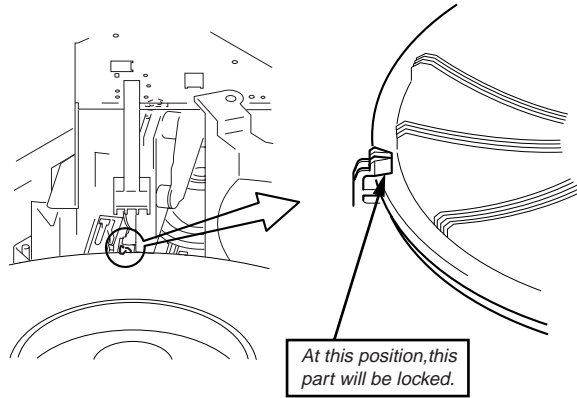
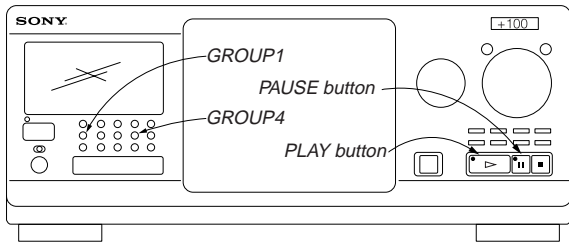

Fig-3

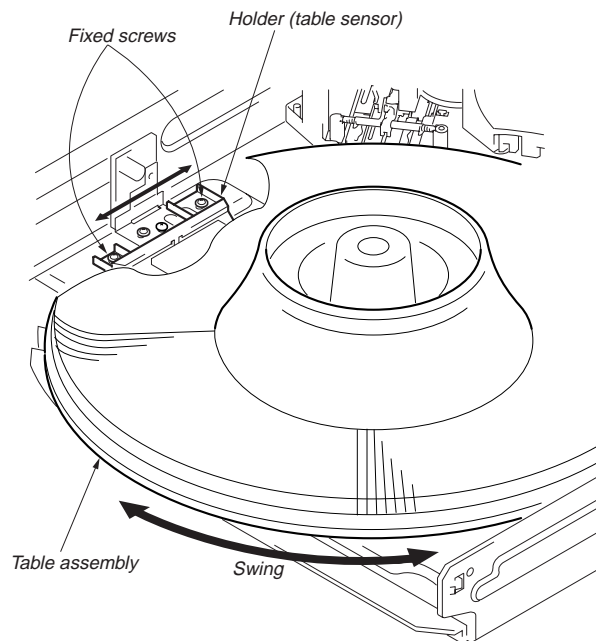
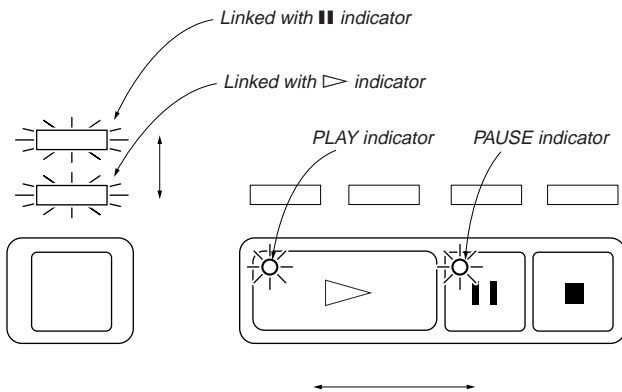

Fig-4

6-2. ELECTRICAL ADJUSTMENT

Note:

1. CD Block is basically designed to operate without adjustment. Therefore, check each item in order given.
2. Use YEDS-18 disc (3-702-101-01) unless otherwise indicated.
3. Use an oscilloscope with more than 10MΩ impedance.
4. Clean the object lens by an applicator with neutral detergent when the signal level is low than specified value with the following checks.

S-Curve Check

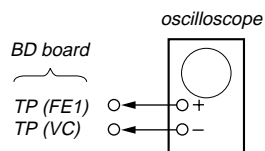

Procedure :

1. Chuck the disc (YEDS-18) beforehand, and disconnect the power cord from the outlet.
2. Connect oscilloscope to test point TP (FE1) on BD board.
3. Connect test point TP1 (ADJ) on MAIN board to ground with lead wire.
4. The ADJ mode is set when the power cord is inserted into the outlet and power is supplied.
5. The fifth track is played automatically.
6. Press the **CHECK** button.
7. Check the oscilloscope waveform (S-curve) is symmetrical between A and B. And confirm peak to peak level within 3 ± 1 Vp-p.

S-curve waveform

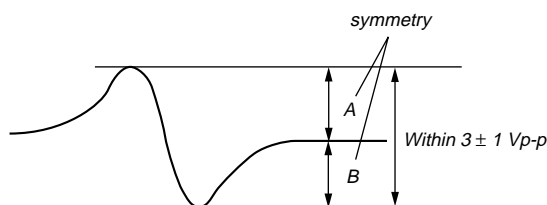

8. Pressing the **I/⏻** button stops the output of the waveform (s curve).
9. After check, remove the lead wire connected in step 3.

Note :

- Try to measure several times to make sure than the ratio of A : B or B : A is more than 10 : 7.
- Take sweep time as long as possible and light up the brightness to obtain best waveform.

Adjustment Location: BD board

RF Level Check

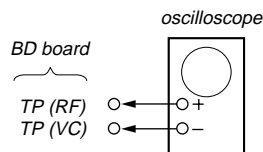

Procedure :

1. Connect oscilloscope to test point TP (RF) on BD board.
2. Turn Power switch on.
3. Put disc (YEDS-18) in to play the number five track.
4. Confirm that oscilloscope waveform is clear and check RF signal level is correct or not.

Note: A clear RF signal waveform means that the shape “ \diamond ” can be clearly distinguished at the center of the waveform.

RF signal waveform

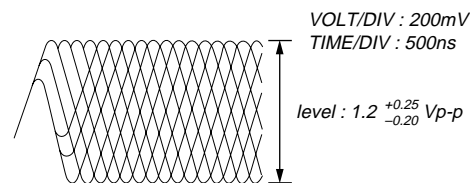

Adjustment Location: BD board

E-F Balance Check

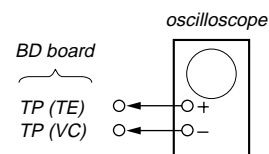

Procedure :

1. Chuck the disc (YEDS-18) beforehand, and disconnect the power cord from the outlet.
2. Connect oscilloscope to test point TP (TE) on BD board.
3. Connect test point TP1 (ADJ) on MAIN board to ground with lead wire.
4. The ADJ mode is set when the power cord is inserted into the outlet and power is supplied.
5. The fifth track is played automatically.
6. Press the **GROUP 3** button. (The tracking servo and the sledding servo are turned OFF.)
7. Check the level B of the oscilloscope's waveform and the A (DC voltage) of the center of the Traverse waveform.

Confirm the following :
 $A/B \times 100 = \text{less than } \pm 22\%$

Traverse waveform

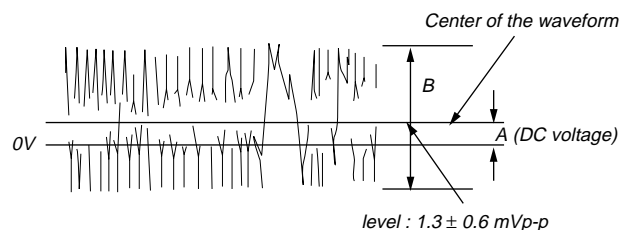

8. Press the **GROUP 8** button. (The tracking servo and sledding servo are turned ON.) Confirm the C (DC voltage) is almost equal to the A (DC voltage) is step 7.

Traverse waveform

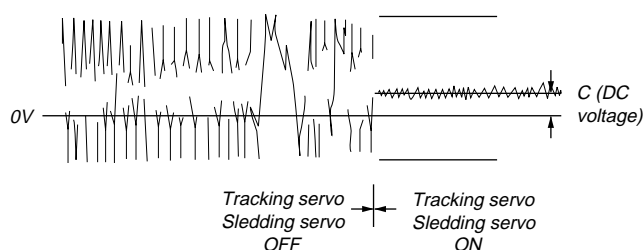

9. Disconnect the lead wire of TP1 (ADJ) connected in step 2.

Adjustment Location: MAIN board

Disc Sensor Adjustment

Be sure to perform this adjustment after sensor adjustment in MECHANICAL ADJUSTMENT.

Connection:

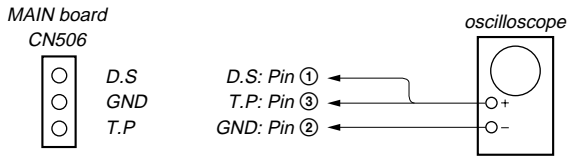

Waveform:

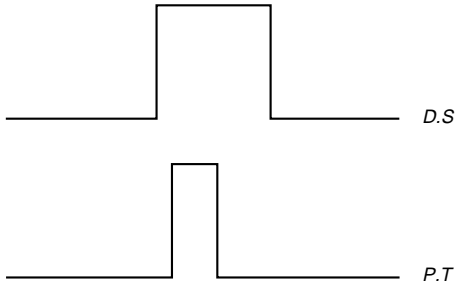

1. Connect the oscilloscope to Pins ①, ②, and ③ of CN506 of the MAIN board.
2. Check that no discs are loaded in the unit.
3. With the power ON, while pressing the **GROUP 5** and **OPEN/CLOSE** buttons, press the **+100** button. The disc table starts to rotate in the clockwise direction.
4. Loosen the fixing screw, move the mounting board (SENSOR), and secure the mounting board (SENSOR) at the point the H portion of the P.T waveform comes the center of the H portion of the D.S waveform.

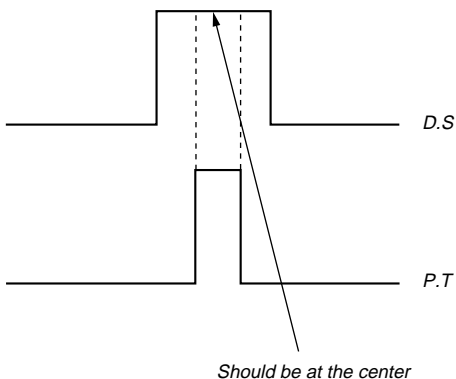
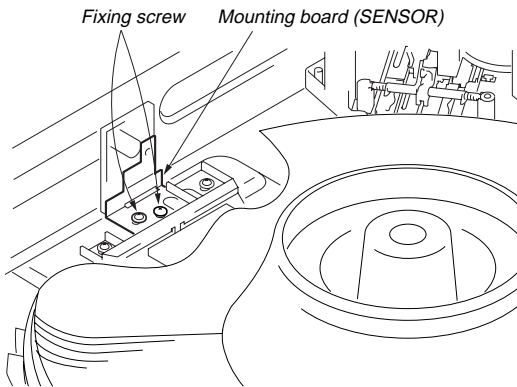

5. Rotate the **DISC/CHARACTER** knob in the counterclockwise direction and the disc table starts to rotate in the same direction. Check that the waveform at this time is the same as that in step 4. If larger by a considerable extent, rotate the **DISC/CHARACTER** knob in the clockwise direction and the disc table starts to rotate in the same direction. Repeat from step 4.
6. Rotate RV501 of the MAIN board and adjust so that the H and L portions of the D.S waveform become the same.

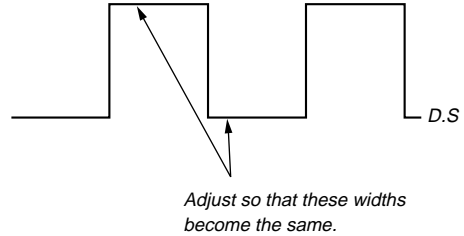

Adjustment Location: MAIN board

Adjustment Location :

[BD BOARD] – Side B –

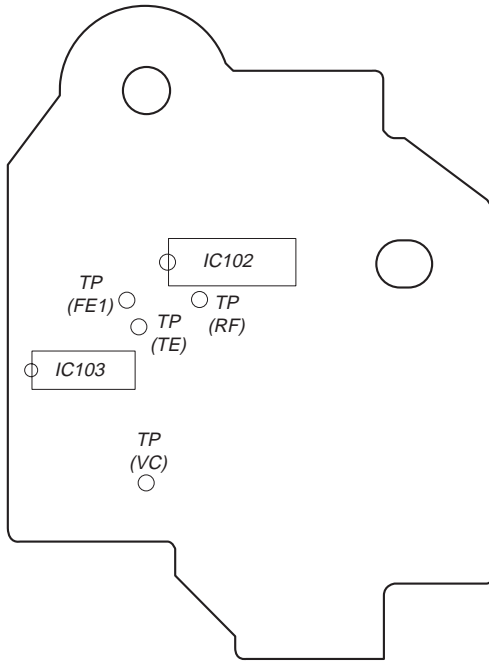

[MAIN BOARD] – Component Side –

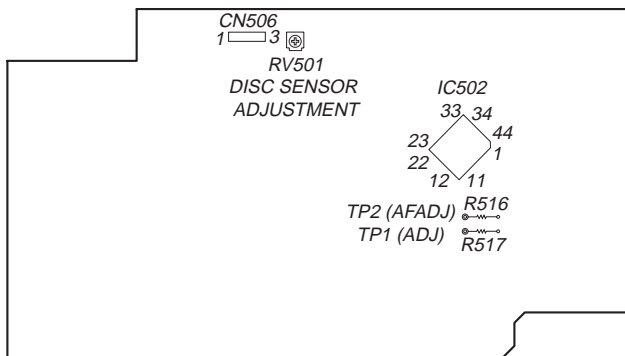

SECTION 7 DIAGRAMS

7-1. CIRCUIT BOARDS LOCATION

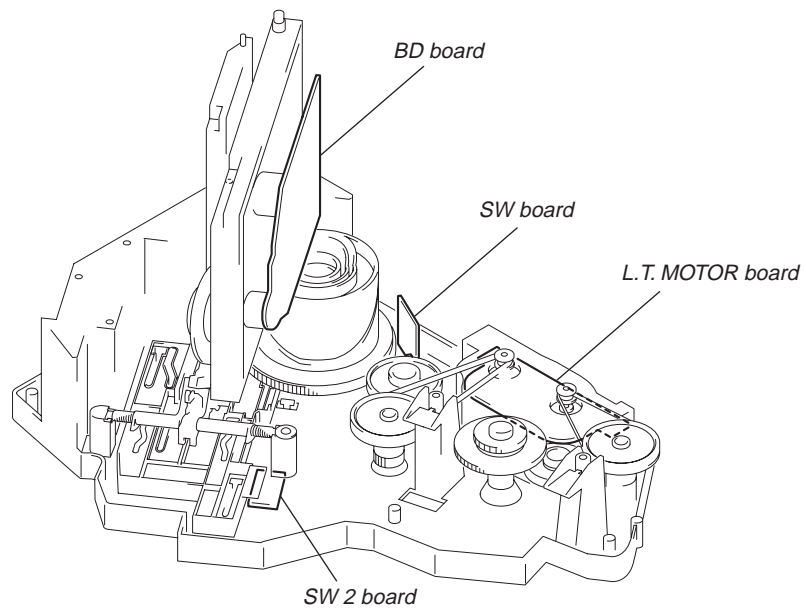
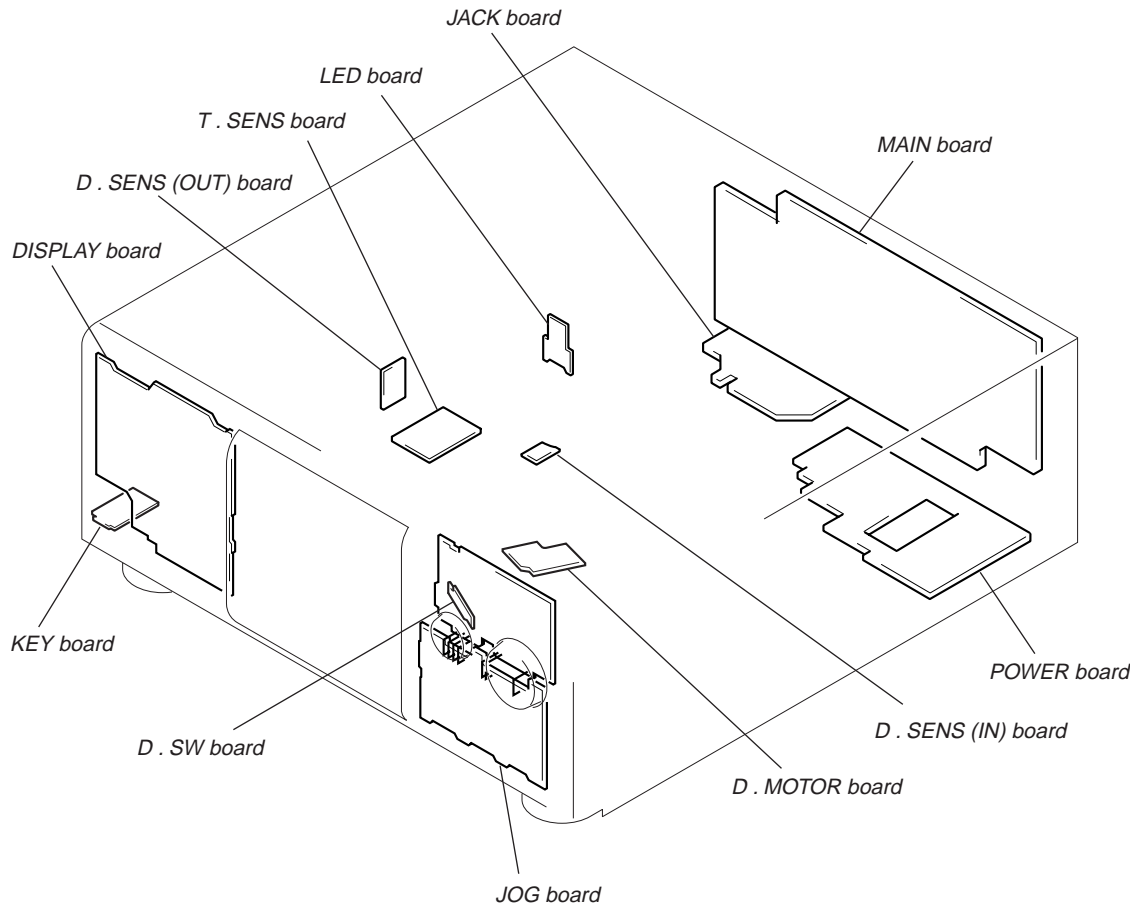

7-2. BLOCK DIAGRAMS
- BD SECTION -

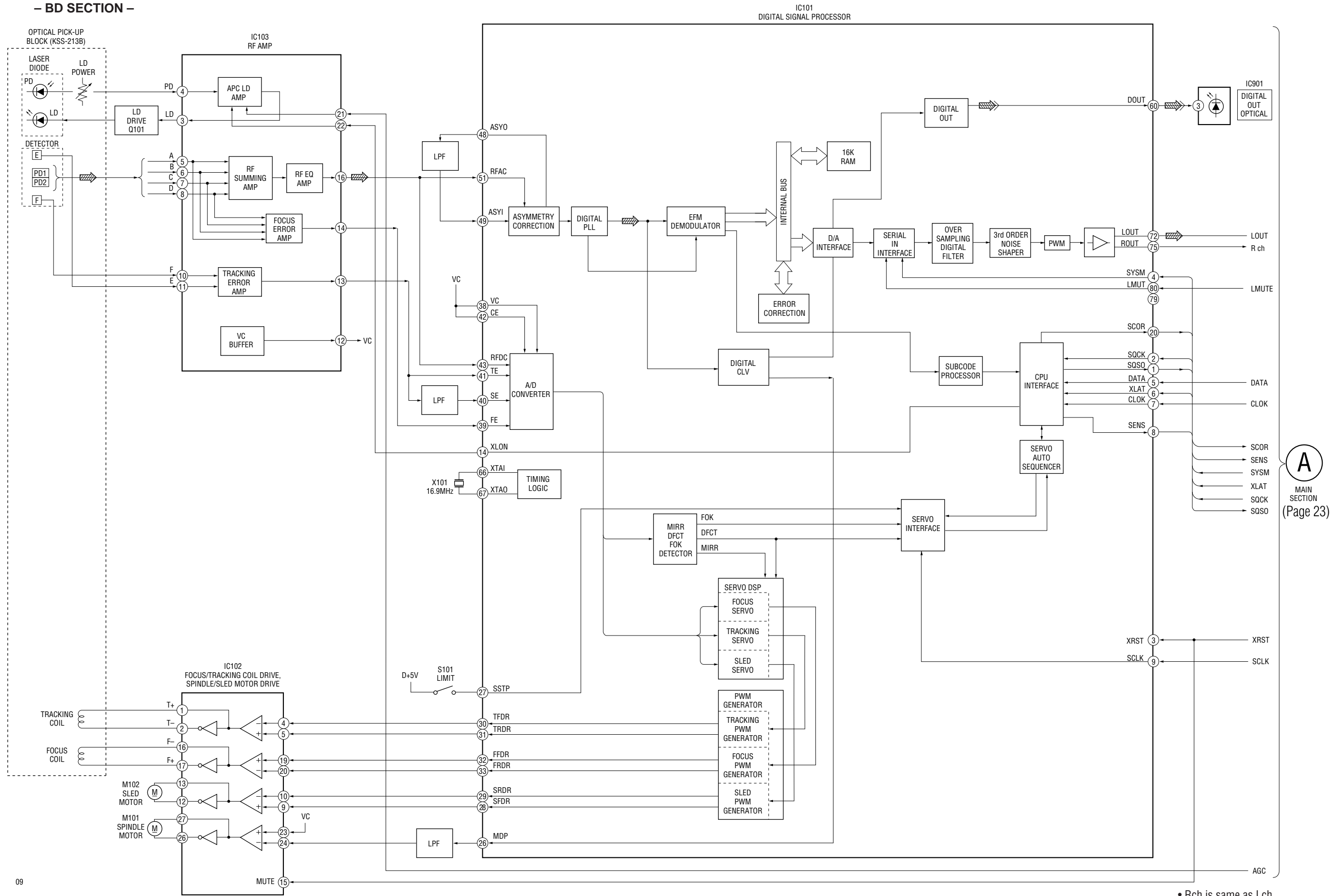

09

• Rch is same as Lch.
• SIGNAL PATH
 : CD
 : CD (digital)

A
MAIN SECTION
(Page 23)

- MAIN SECTION -

A
BD SECTION
(Page 22)

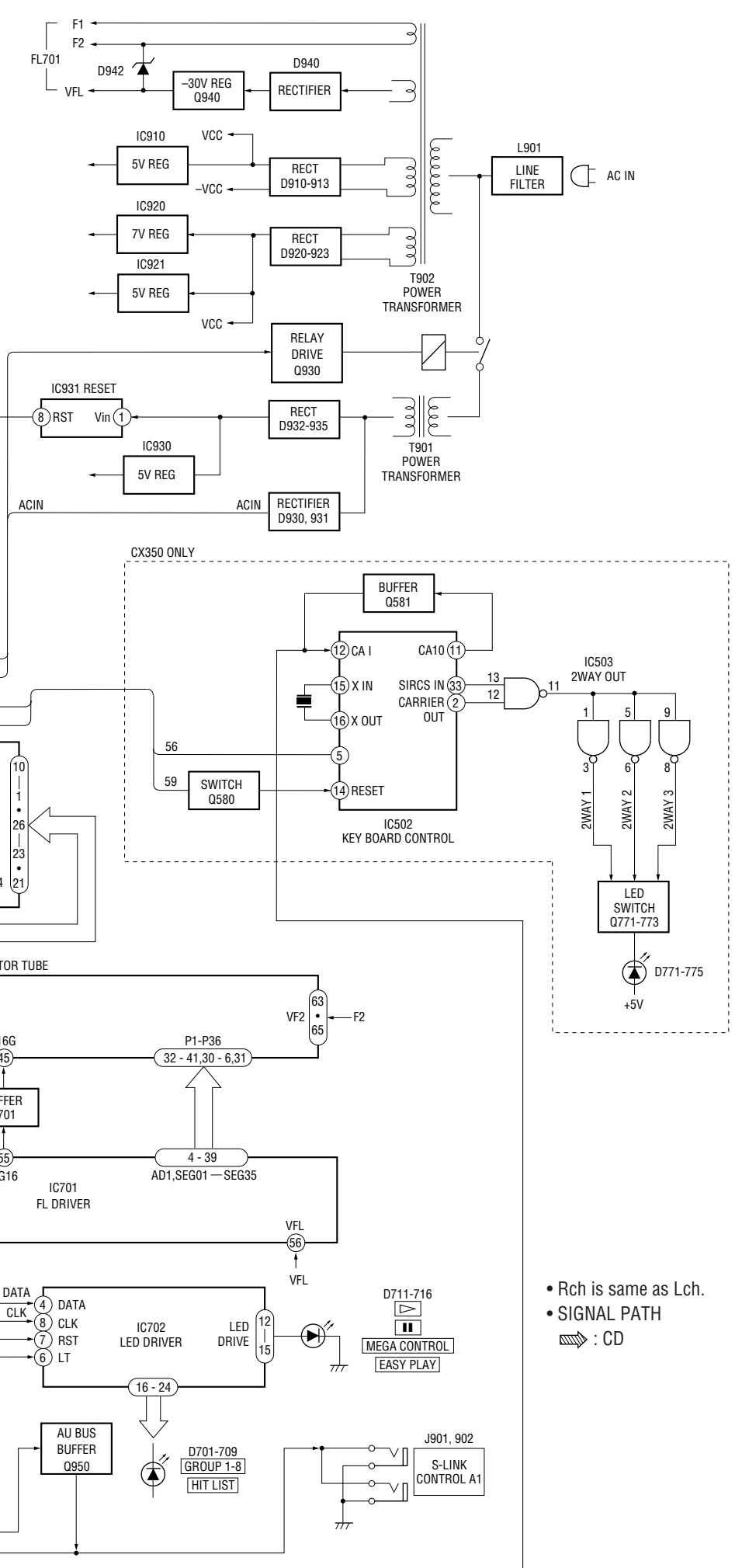
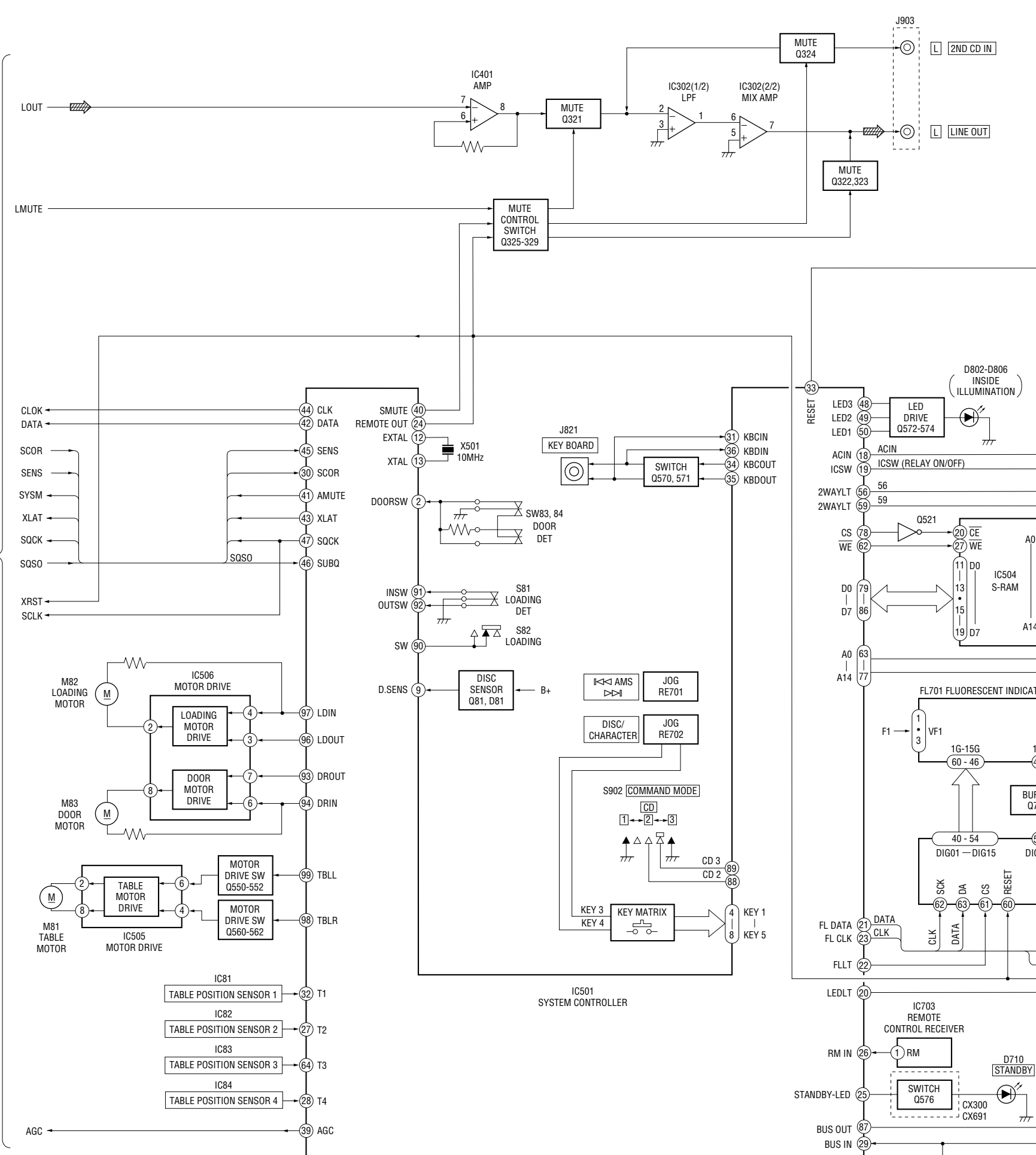

• Rch is same as Lch.
• SIGNAL PATH
▨ : CD

THIS NOTE IS COMMON FOR PRINTED WIRING BOARDS AND SCHEMATIC DIAGRAMS.
(In addition to this, the necessary note is printed in each block.)

For schematic diagrams.

Note:

- All capacitors are in μF unless otherwise noted. pF: μpF
- 50 WV or less are not indicated except for electrolytics and tantalums.
- All resistors are in Ω and $1/4\text{W}$ or less unless otherwise specified.
- Δ : internal component.
- \square : panel designation.

Note:
 The components identified by mark Δ or dotted line with mark Δ are critical for safety.
 Replace only with part number specified.

Note:
 Les composants identifiés par une marque Δ sont critiques pour la sécurité.
 Ne les remplacer que par une pièce portant le numéro spécifié.

- $\text{B}+$: B+ Line.
- $\text{B}-$: B- Line.
- \square : adjustment for repair.
- Voltages and waveforms are dc with respect to ground under no-signal (detuned) conditions.
 no mark : STOP
- Voltages are taken with a VOM (Input impedance $10\text{M}\Omega$).
 Voltage variations may be noted due to normal production tolerances.
- Waveforms are taken with an oscilloscope.
 Voltage variations may be noted due to normal production tolerances.
- Circled numbers refer to waveforms.
- Signal path.
 \Rightarrow : CD
 \Rightarrow : digital out
- Abbreviation
 CND : Canadian model
 AUS : Australian model

For printed wiring boards.

Note:

- \circ : parts extracted from the component side.
- \square : parts extracted from the conductor side.
- \circ : Through hole.
- \square : Pattern from the side which enables seeing.
 (The other layers' patterns are not indicated.)

Caution:
 Pattern face side: Parts on the pattern face side seen from the (Side B) pattern face are indicated.
 Parts face side: Parts on the parts face side seen from the (Side A) parts face are indicated.

• Indication of transistor

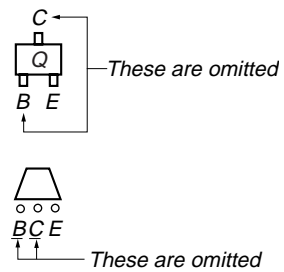

WAVEFORMS

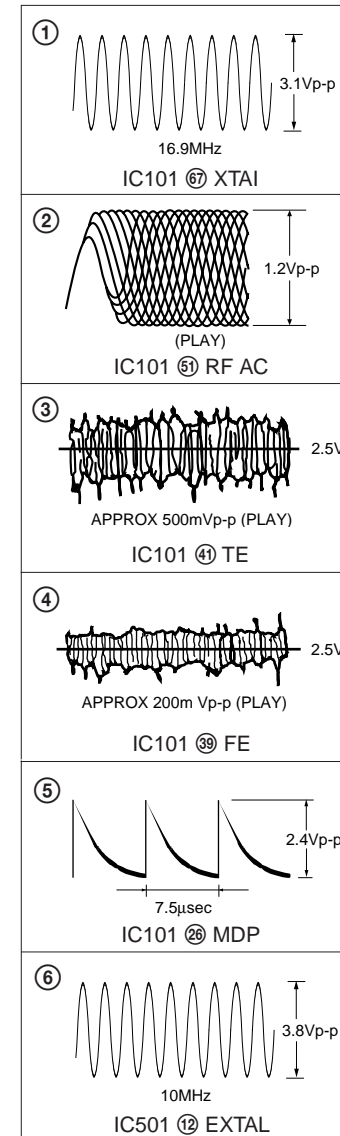

7-3. SCHEMATIC DIAGRAM – BD SECTION –

- See page 26 for Waveforms.
- See page 53, 54 for IC Block Diagrams.
- See page 56 for IC Pin Functions.

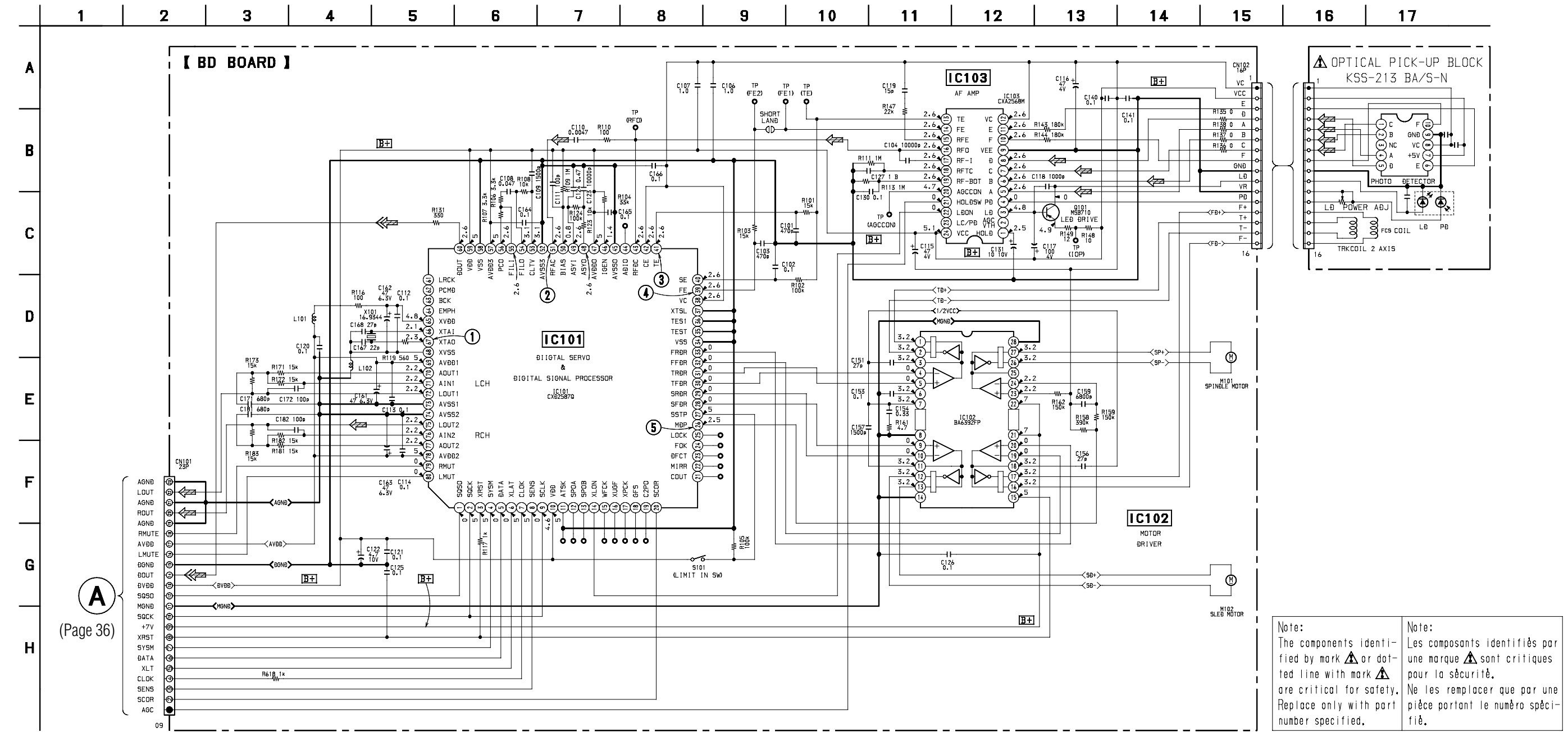

Note: The components identified by mark or dotted line with mark are critical for safety. Replace only with part number specified.

Note: Les composants identifiés par une marque sont critiques pour la sécurité. Ne les remplacer que par une pièce portant le numéro spécifié.

7-4. PRINTED WIRING BOARD – BD SECTION –
 • See page 20 for Circuit Boards Location.

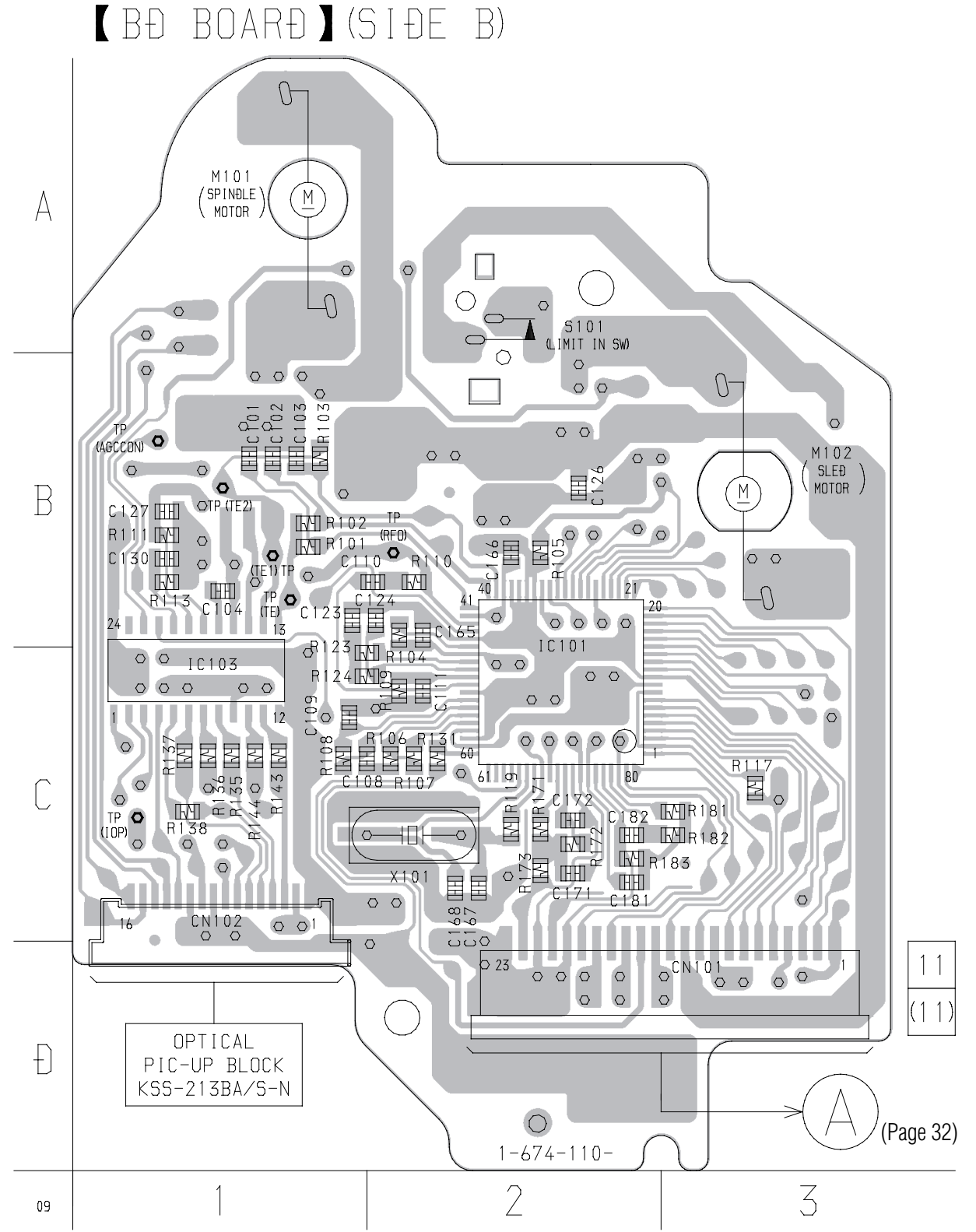
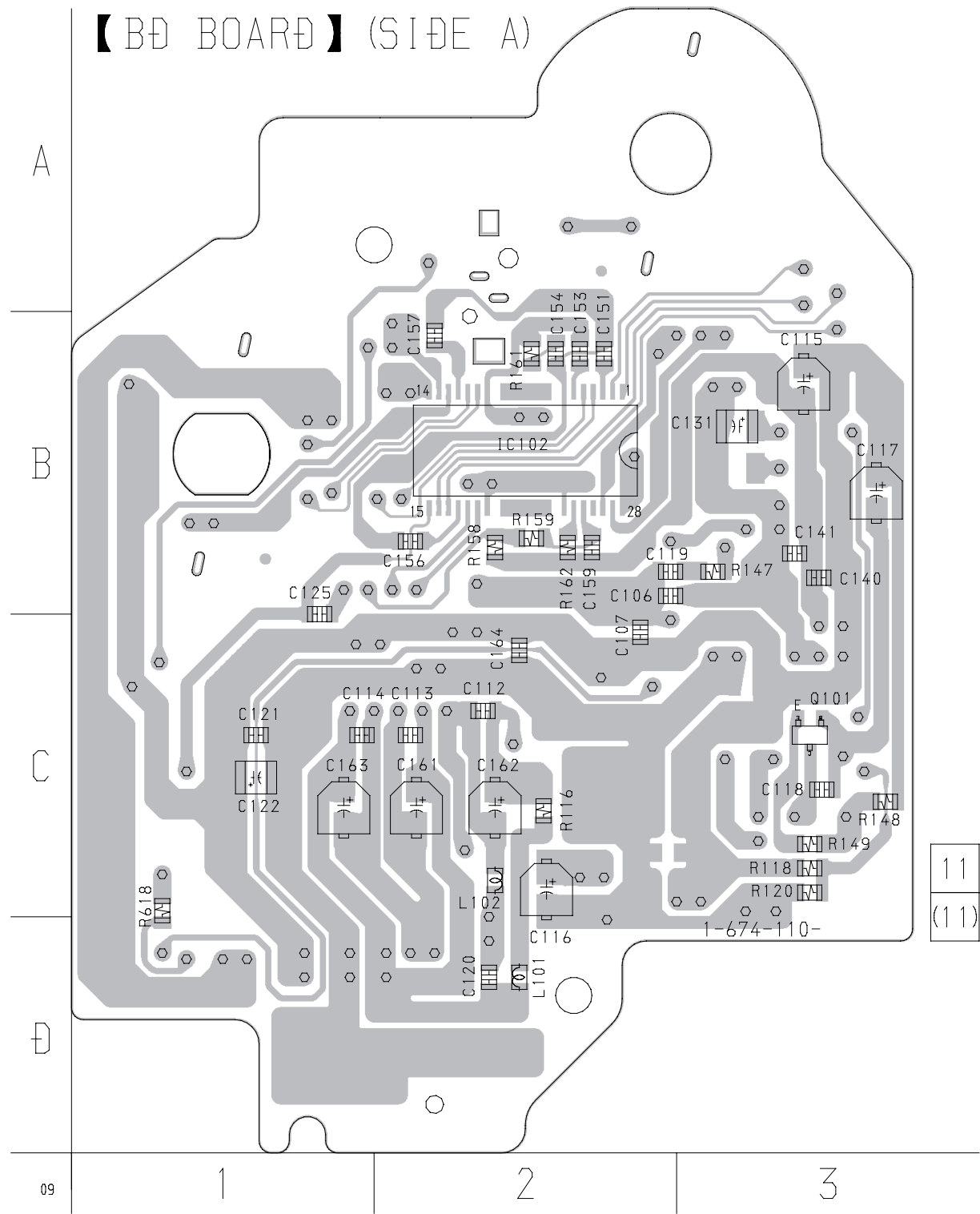

7-6. SCHEMATIC DIAGRAM – MAIN (1/2) SECTION –

- See page 26 for Waveforms.
- See page 54, 55 for IC Block Diagrams.

• See page 58 for IC Pin Functions.

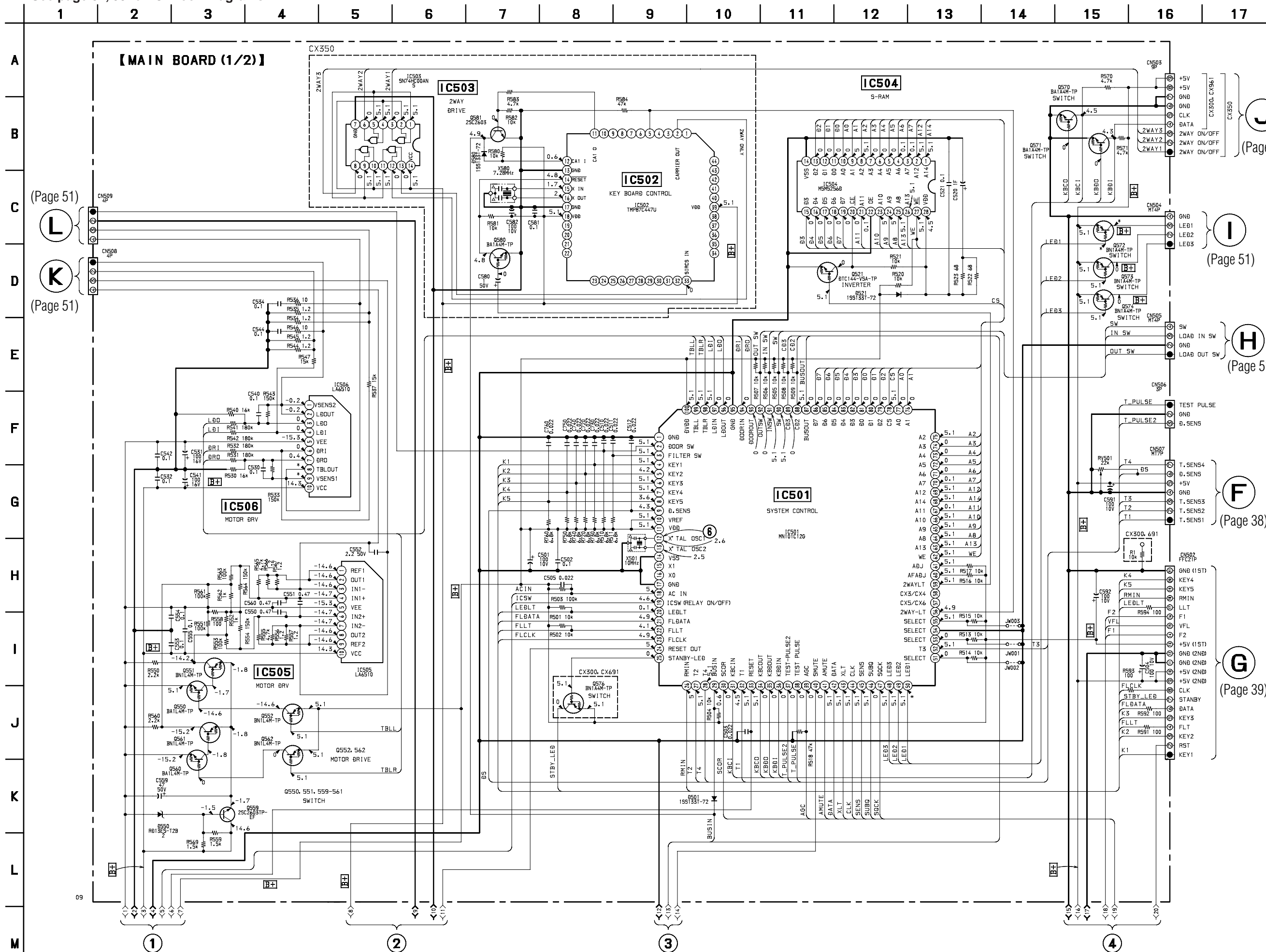

(Page 51)
L
K
(Page 51)

J
(Page 51)

I
(Page 51)

H
(Page 51)

F
(Page 38)

G
(Page 39)

CDP-CX300/CX350/CX691

7-7. SCHEMATIC DIAGRAM – MAIN (2/2) SECTION –

• See page 20 for Waveforms.

• See page 58 for IC Pin Functions.

• See page 54, 55 for IC Block Diagrams.

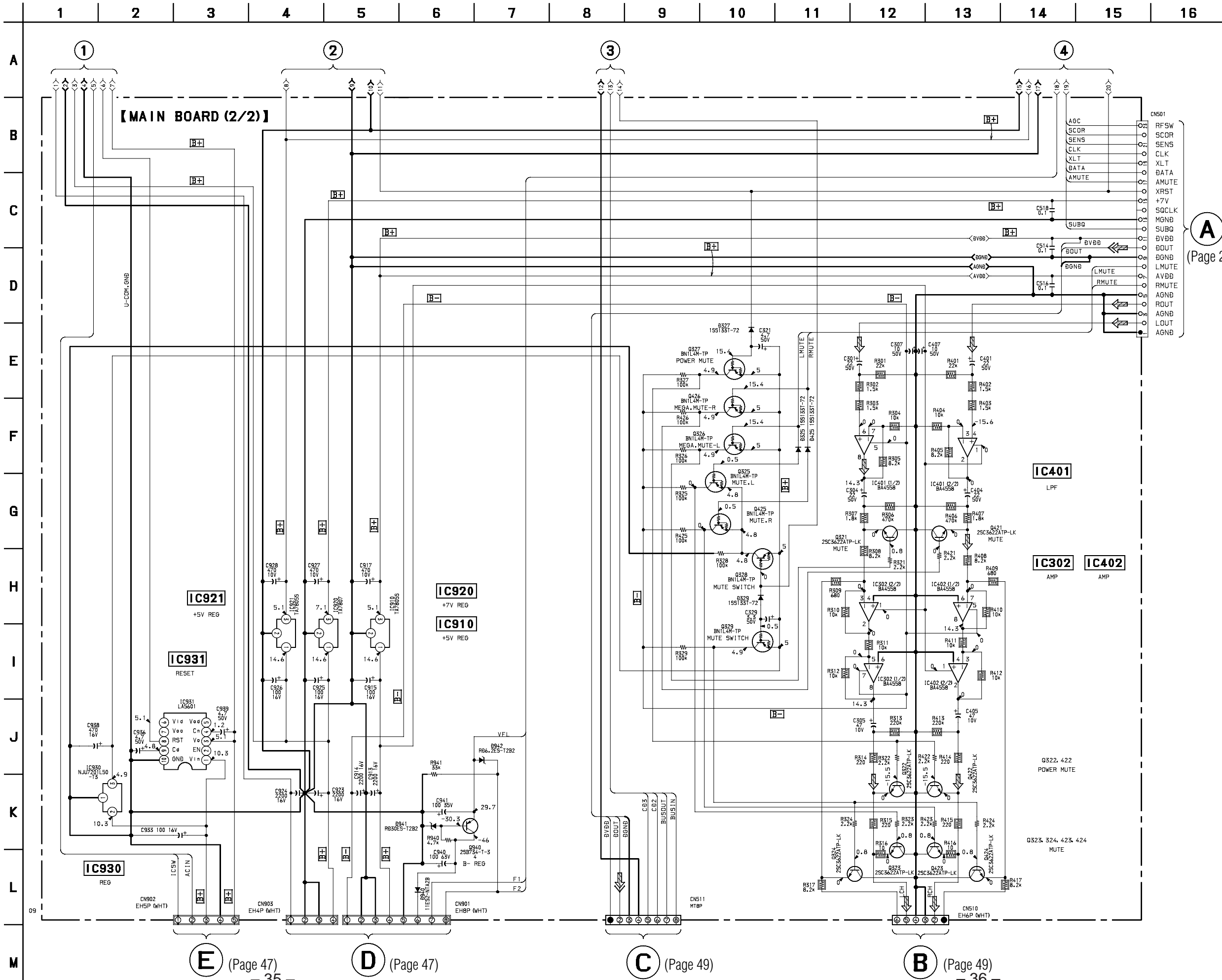

A
(Page 27)

E (Page 47)

D (Page 47)

C (Page 49)

B (Page 49)

7-8. PRINTED WIRING BOARD – T.SENS SECTION –
 • See page 20 for Circuit Boards Location.

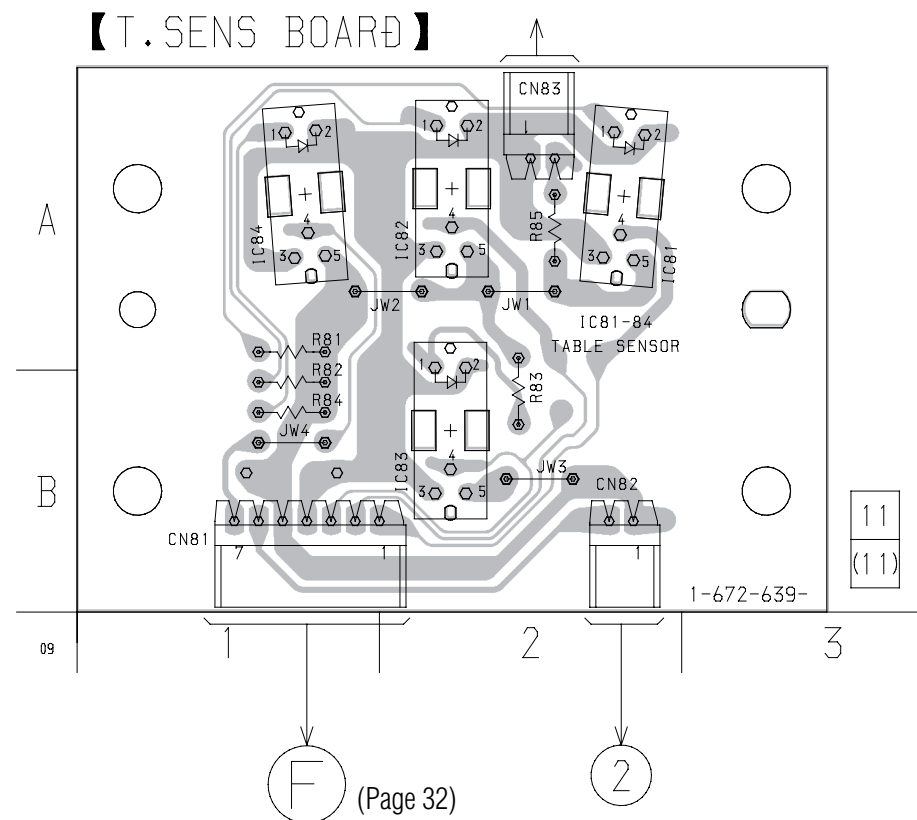

7-9. PRINTED WIRING BOARD – D.SENS (IN) SECTION –
 • See page 20 for Circuit Boards Location.

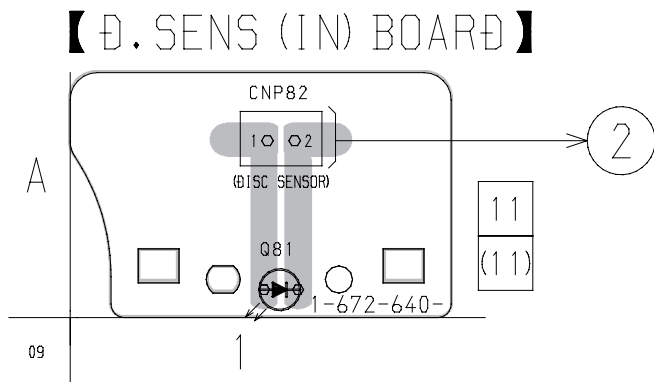

7-10. PRINTED WIRING BOARD – D.SENS (OUT) SECTION –
 • See page 20 for Circuit Boards Location.

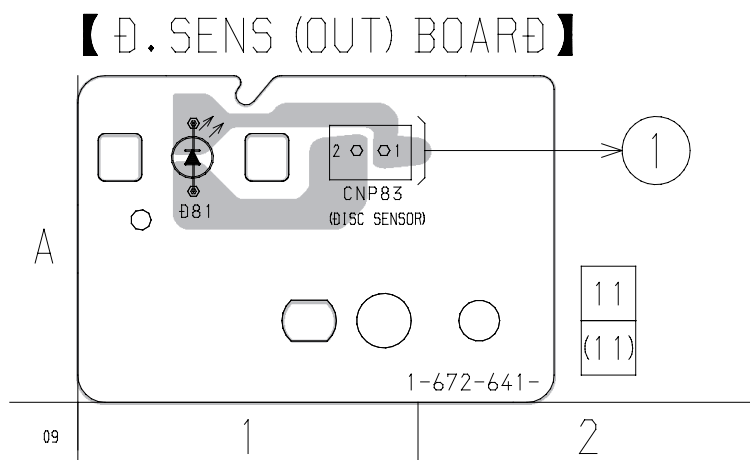

7-11. SCHEMATIC DIAGRAM – SENSOR SECTION –
 • See page 26 for Waveforms.

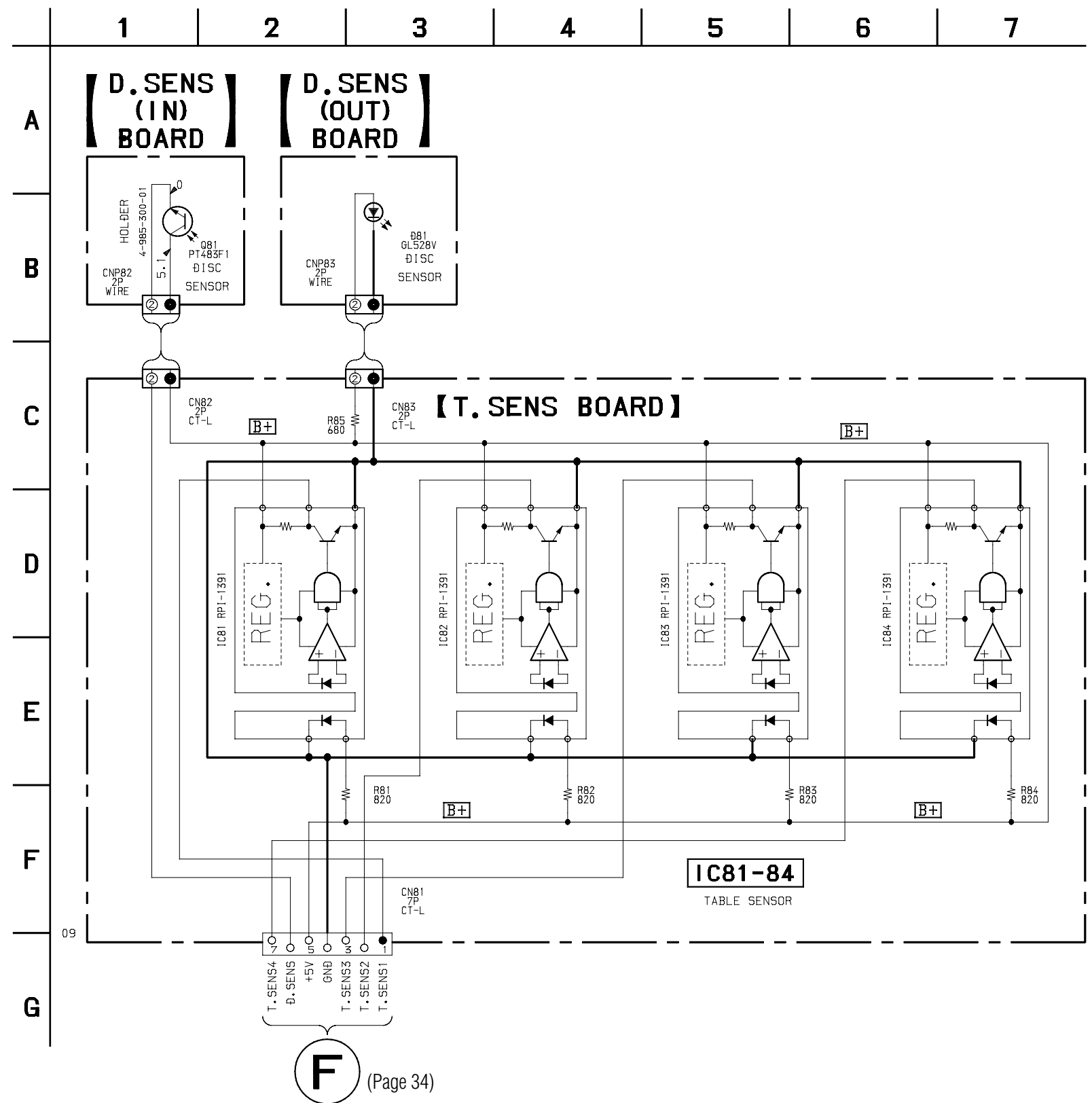

7-12. SCHEMATIC DIAGRAM – DISPLAY SECTION –

• See page 26 for Waveforms.

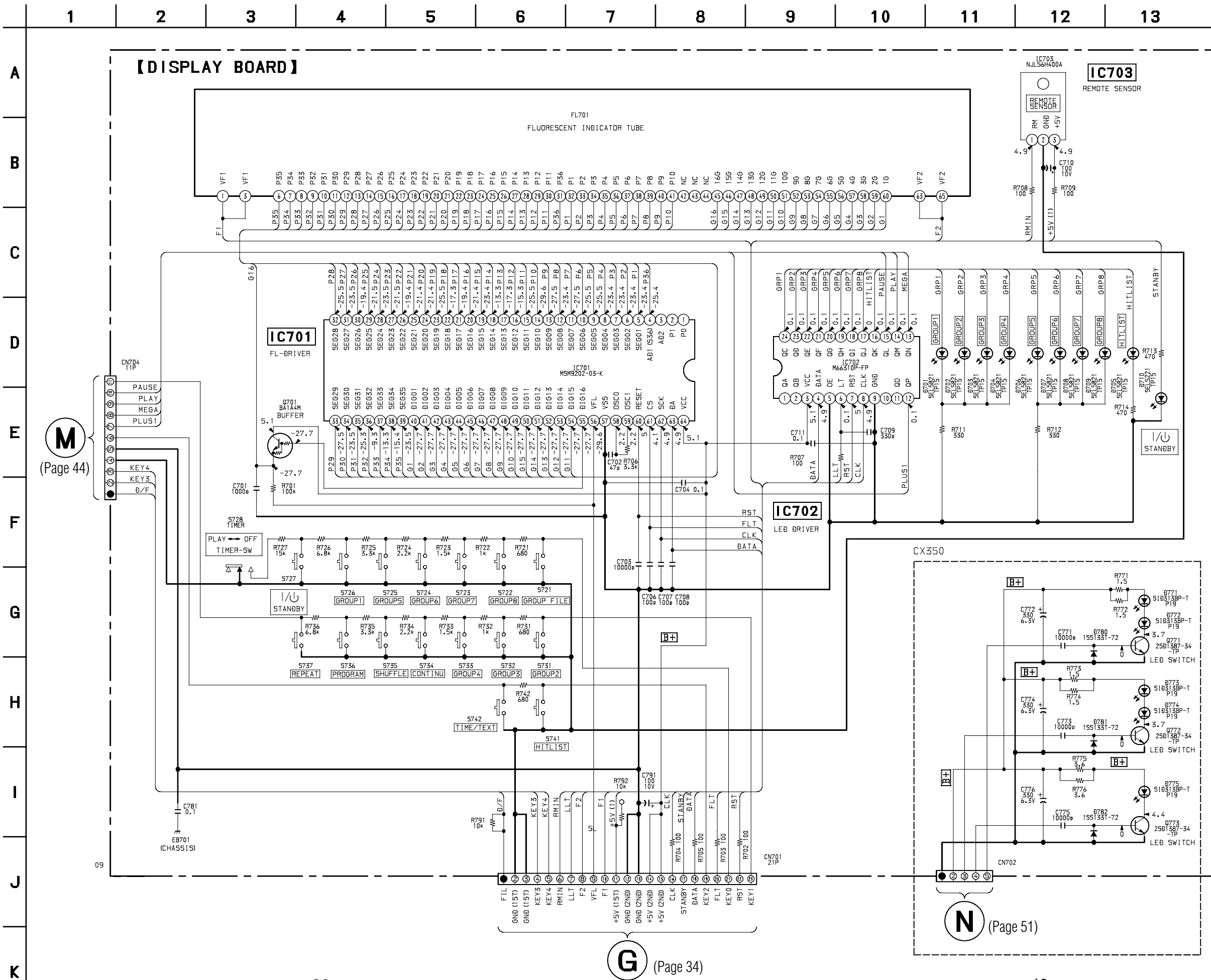

M (Page 44)

G (Page 34)

N (Page 51)

7-13. PRINTED WIRING BOARD – DISPLAY SECTION –
 • See page 20 for Circuit Boards Location.

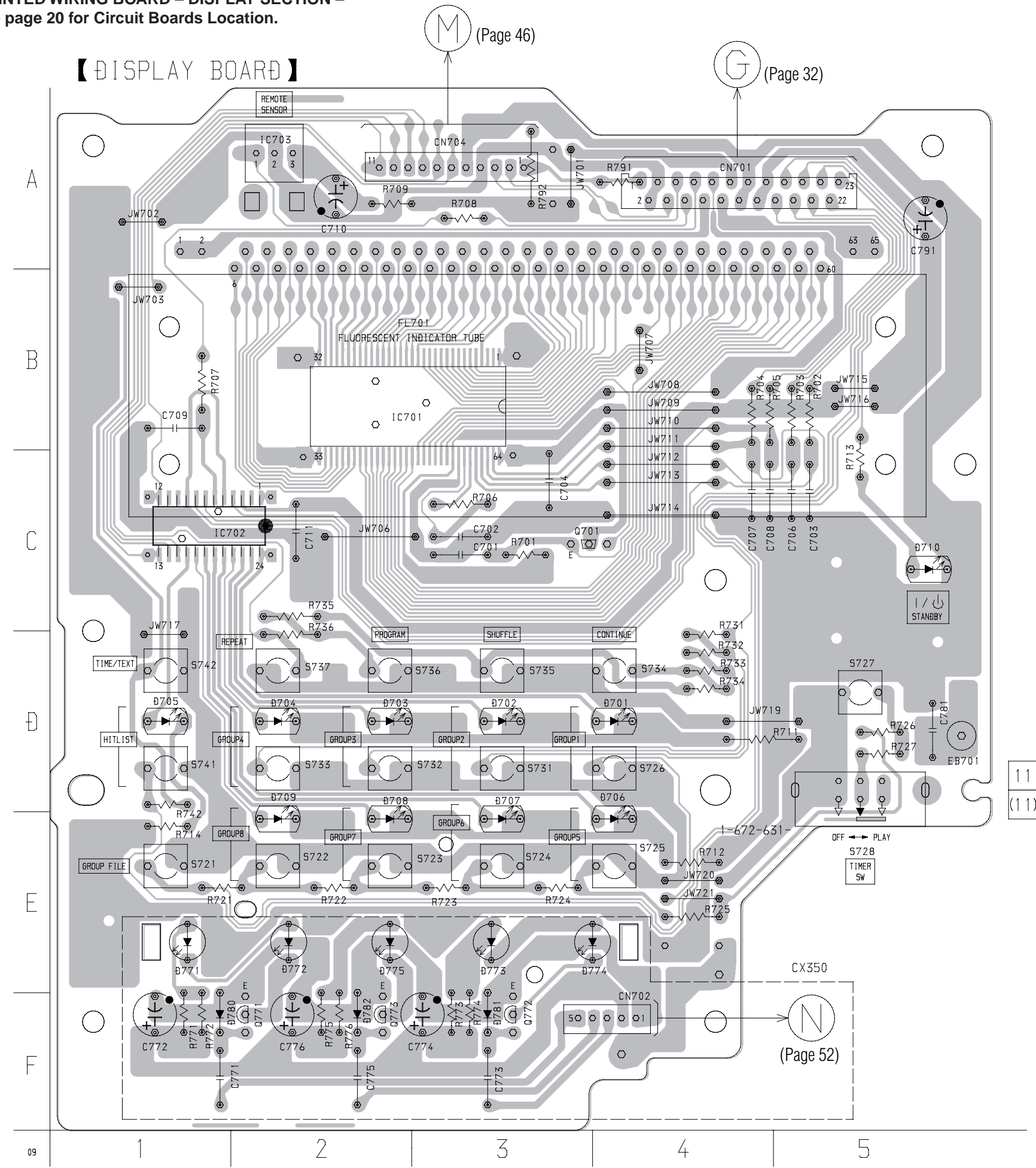

• Semiconductor Location

Ref. No.	Location
D701	D-4
D702	D-3
D703	D-2
D704	D-2
D705	D-1
D706	E-4
D707	E-3
D708	E-2
D709	E-2
D710	C-5
D771	E-1
D772	E-2
D773	E-3
D774	E-4
D775	E-2
D780	F-1
D781	F-3
D782	F-2
IC701	B-2
IC702	C-1
IC703	A-2
Q701	C-3
Q771	F-2
Q772	F-3
Q773	F-2

7-14. SCHEMATIC DIAGRAM – JOG SECTION –
 • See page 26 for Waveforms.

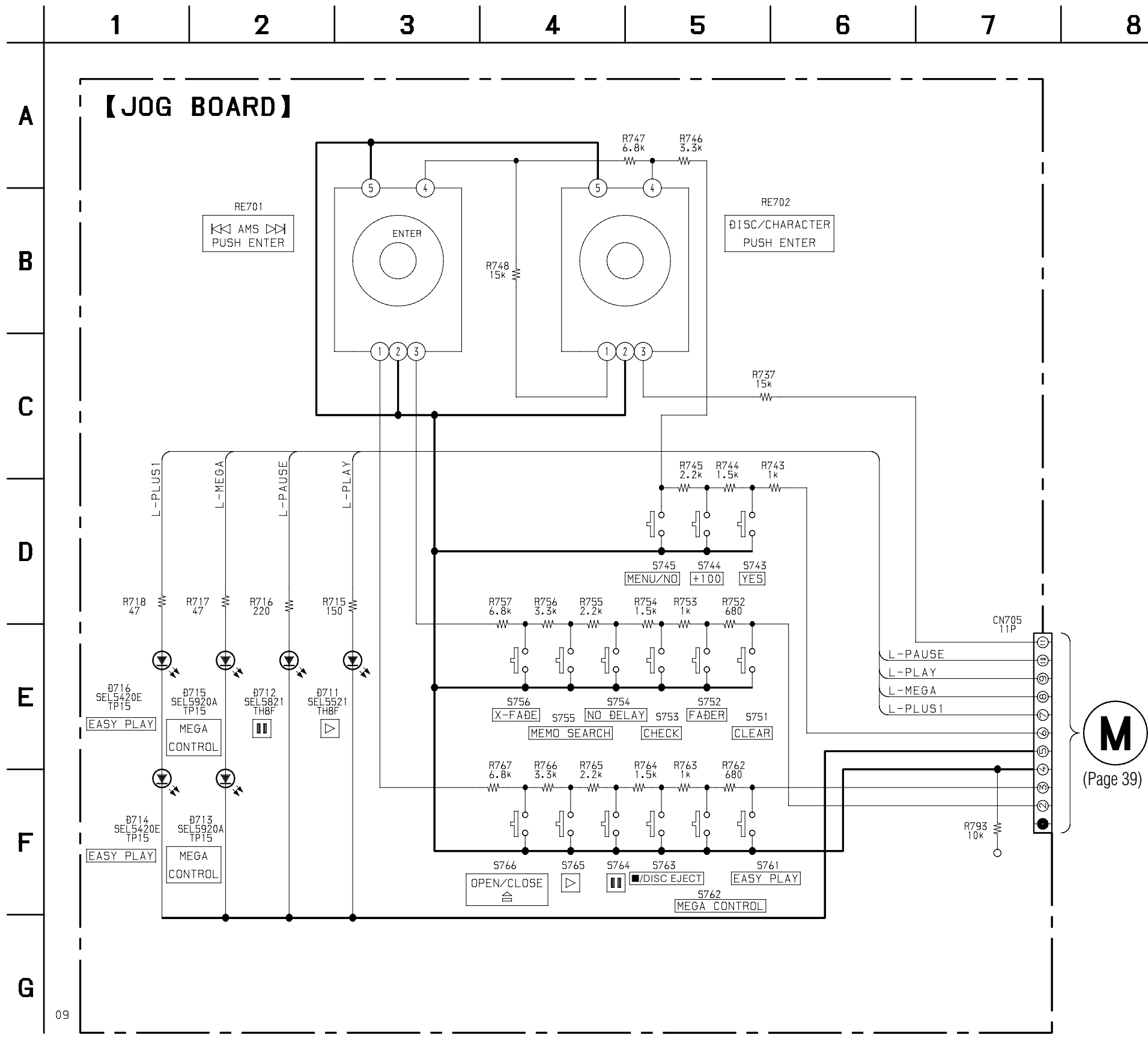

M
 (Page 39)

7-15. PRINTED WIRING BOARD – JOG SECTION –
 • See page 20 for Circuit Boards Location.

【 JOG BOARD】

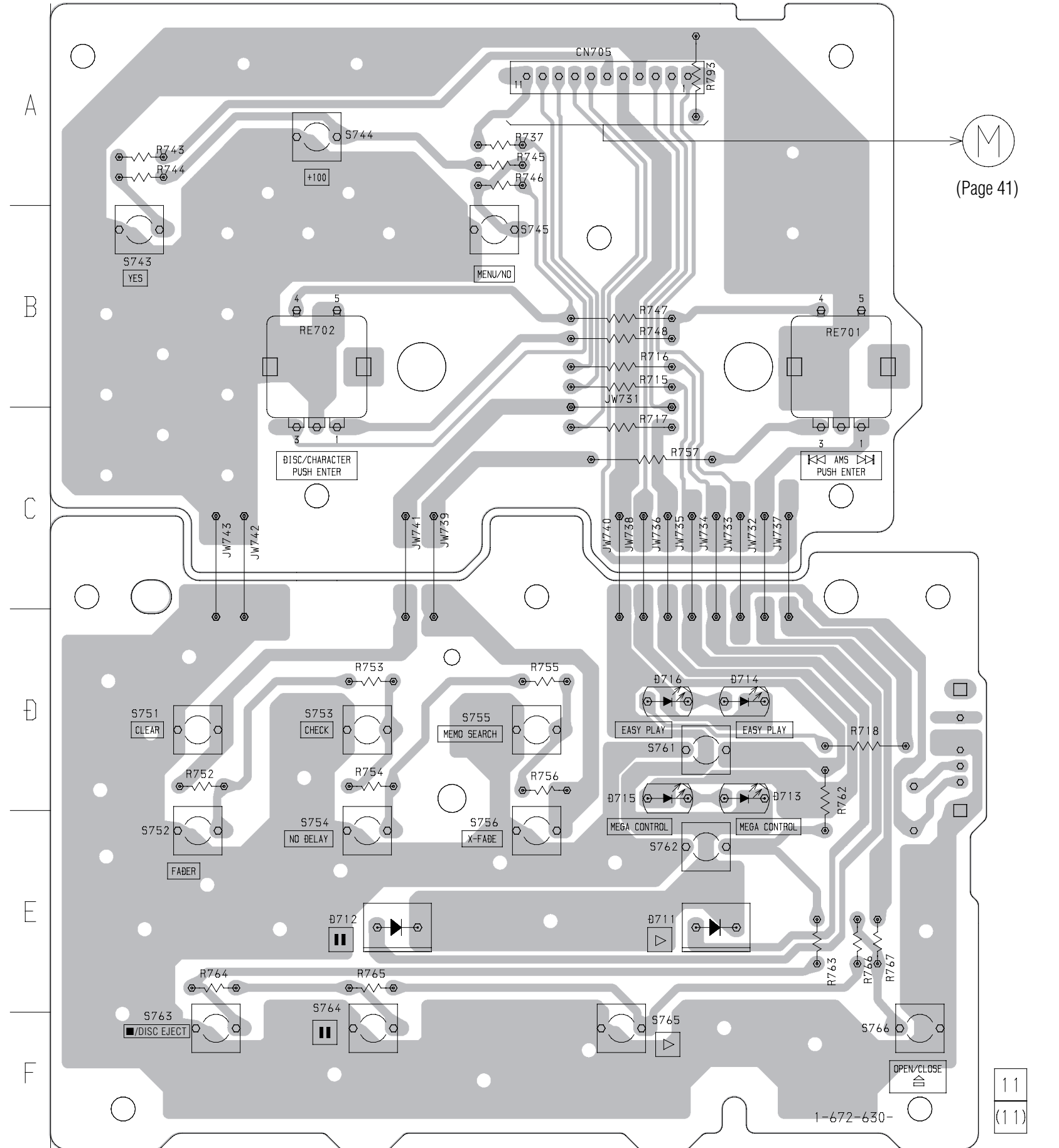



• Semiconductor Location

Ref. No.	Location
D771	D-4
D712	E-2
D713	D-4
D714	D-4
D715	D-4
D716	D-4

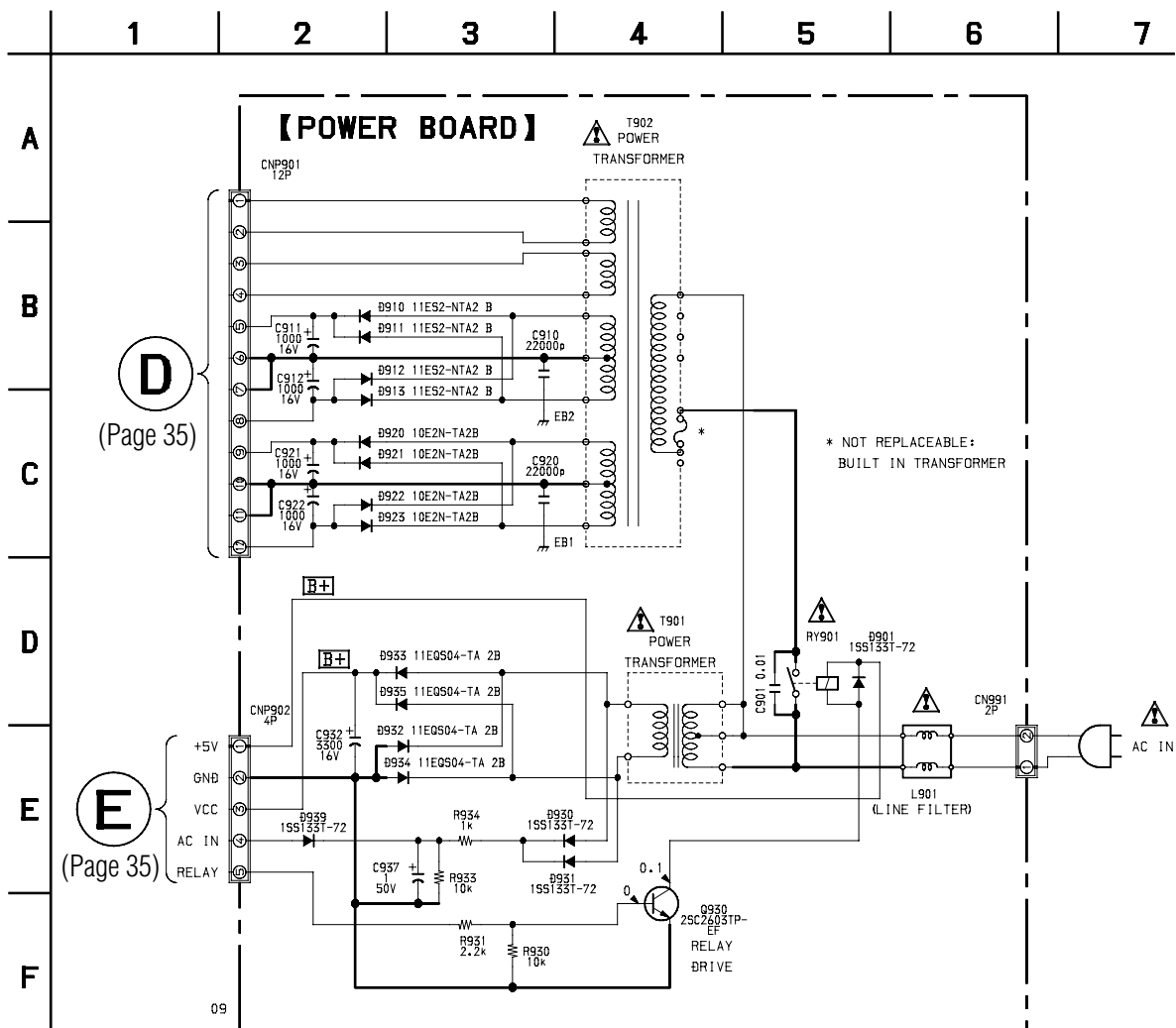
7-16. SCHEMATIC DIAGRAM – POWER SECTION –
• See page 26 for Waveforms.



Note:
The components identified by mark  or dotted line with mark  are critical for safety. Replace only with part number specified.

Note:
Les composants identifiés par une marque  sont critiques pour la sécurité. Ne les remplacer que par une pièce portant le numéro spécifié.

7-17. PRINTED WIRING BOARD – POWER SECTION –
• See page 20 for Circuit Boards Location.

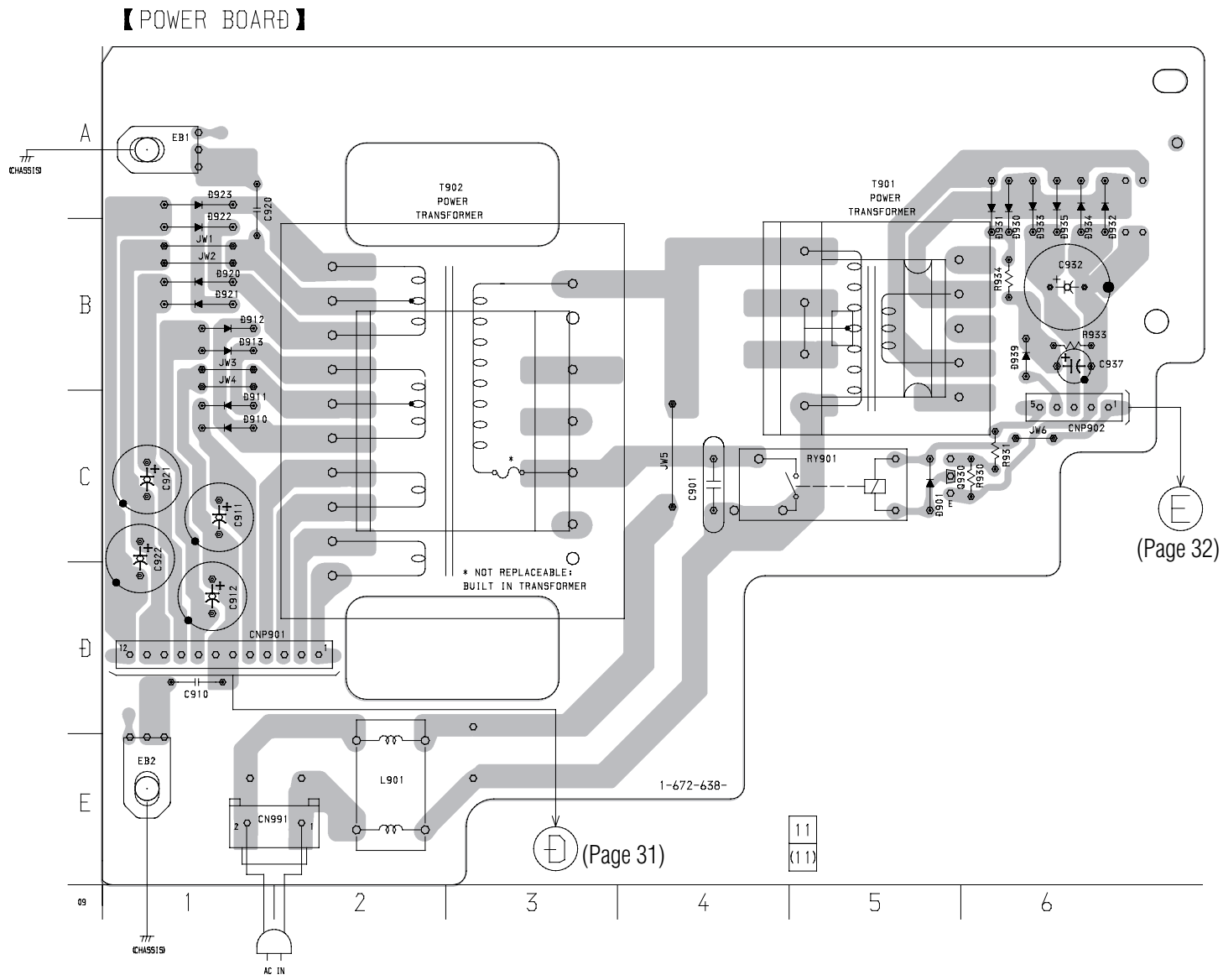

• Semiconductor Location

Ref. No.	Location
D901	C-5
D910	C-1
D911	C-1
D912	B-1
D913	B-1
D920	B-1
D921	B-1
D922	B-1
D923	A-1
D930	B-6
D931	B-6
D932	B-6
D933	B-6
D934	B-6
D935	B-6
D939	B-6

7-18. SCHEMATIC DIAGRAM – JACK SECTION –
 • See page 26 for Waveforms.

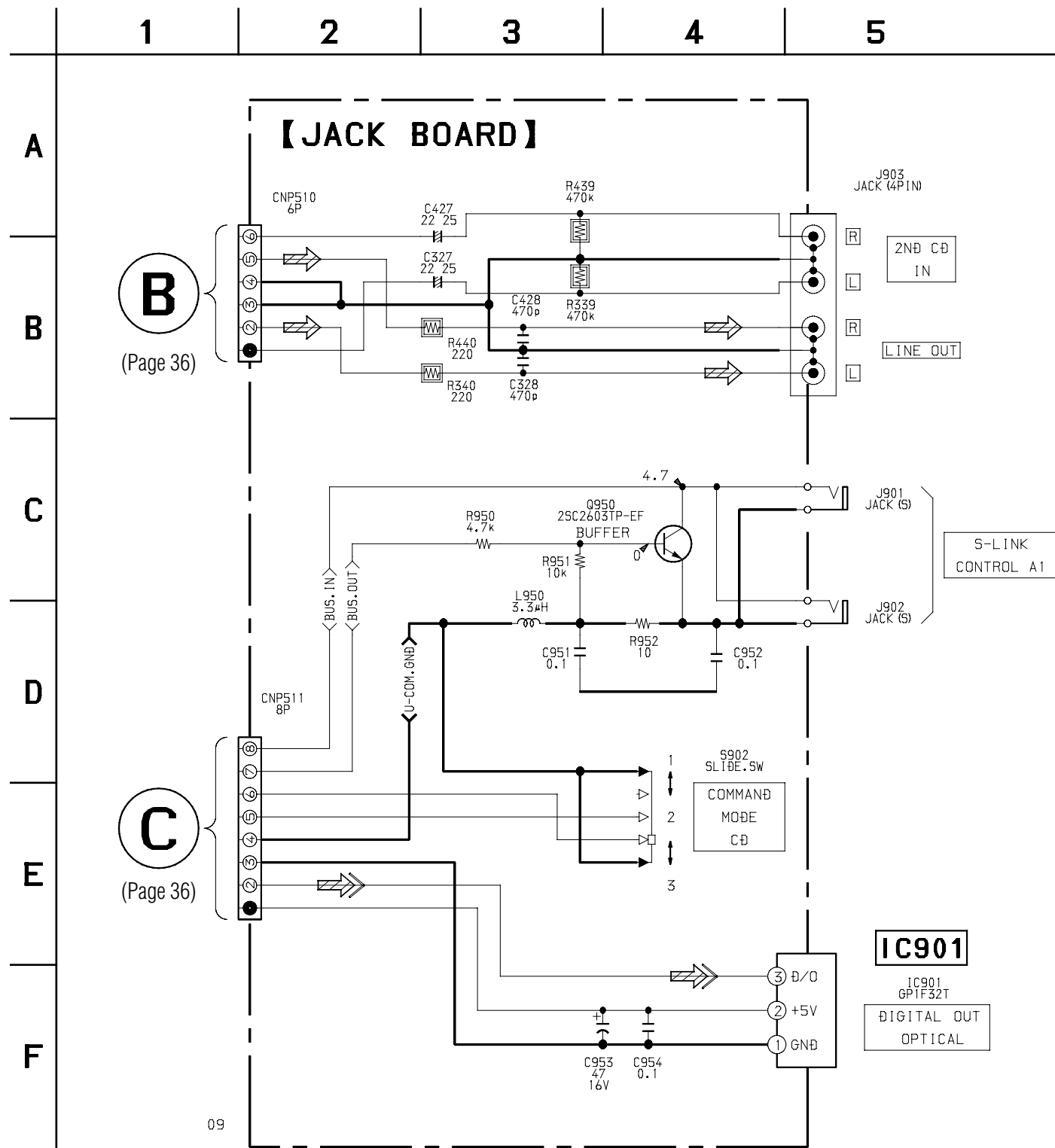

7-19. PRINTED WIRING BOARD – JACK SECTION –
 • See page 20 for Circuit Boards Location.

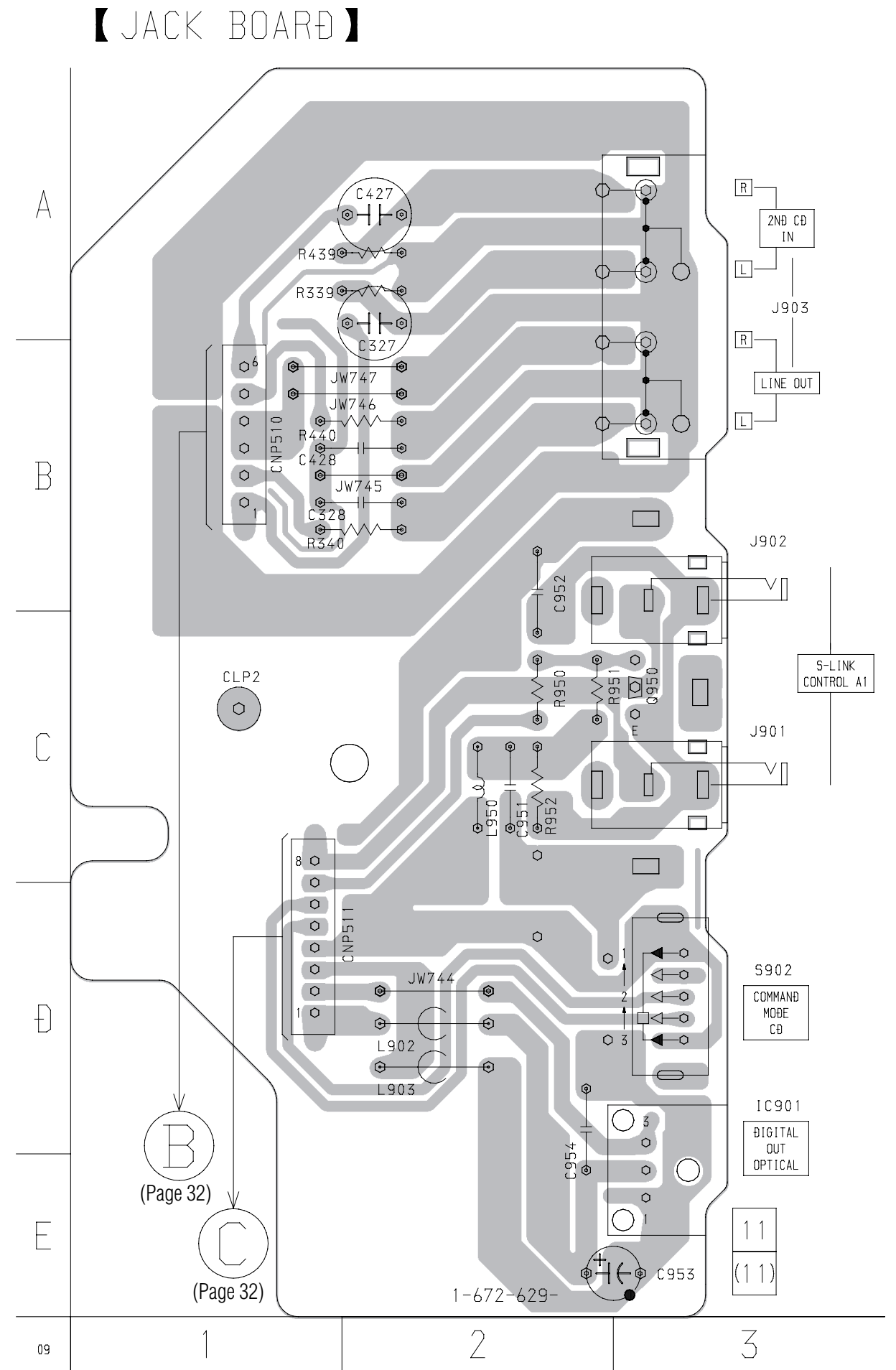

7-20. SCHEMATIC DIAGRAM – SENSOR/MOTOR SECTION –

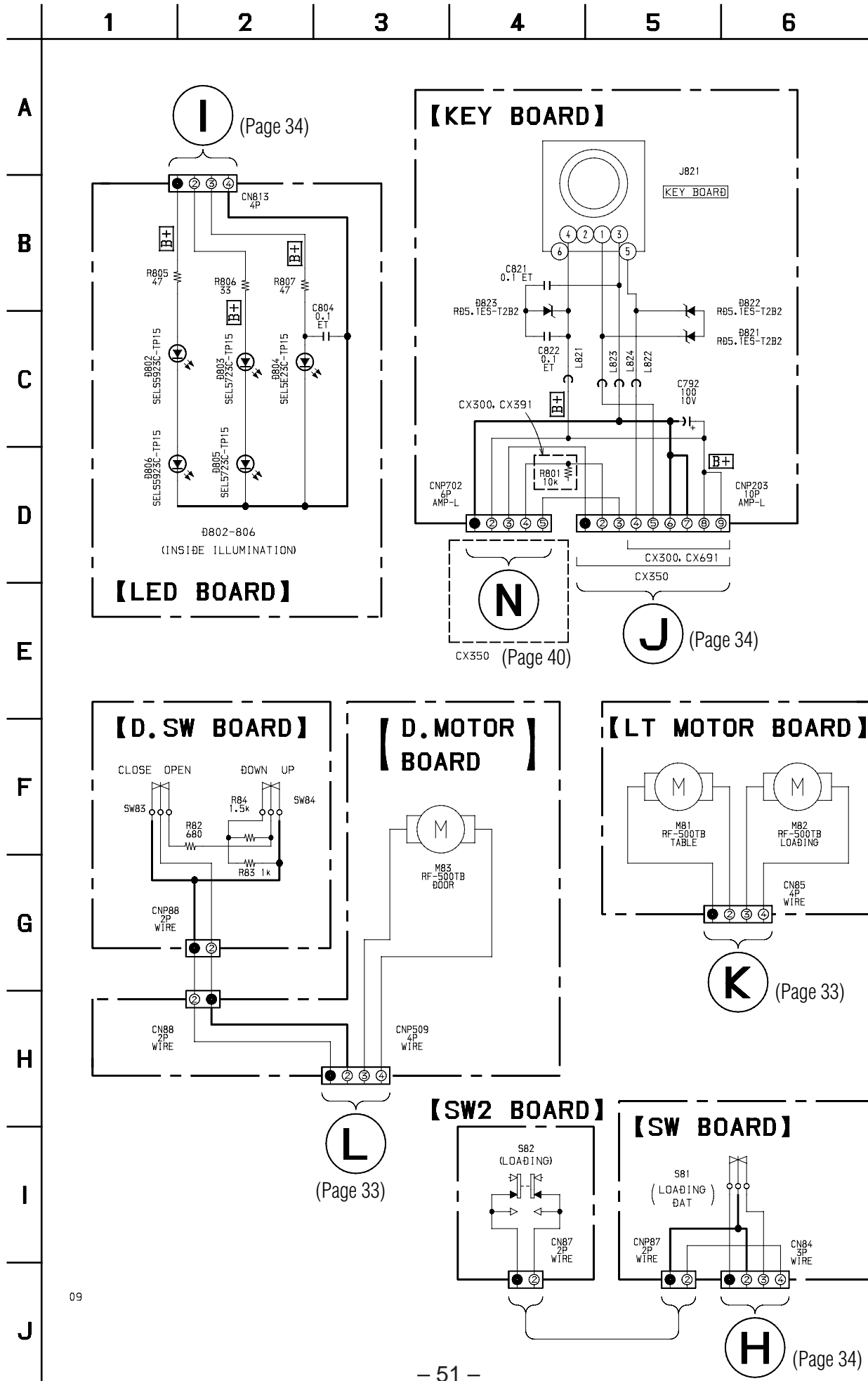

7-21. PRINTED WIRING BOARD – SENSOR/MOTOR SECTION –
• See page 20 for Circuit Boards Location.

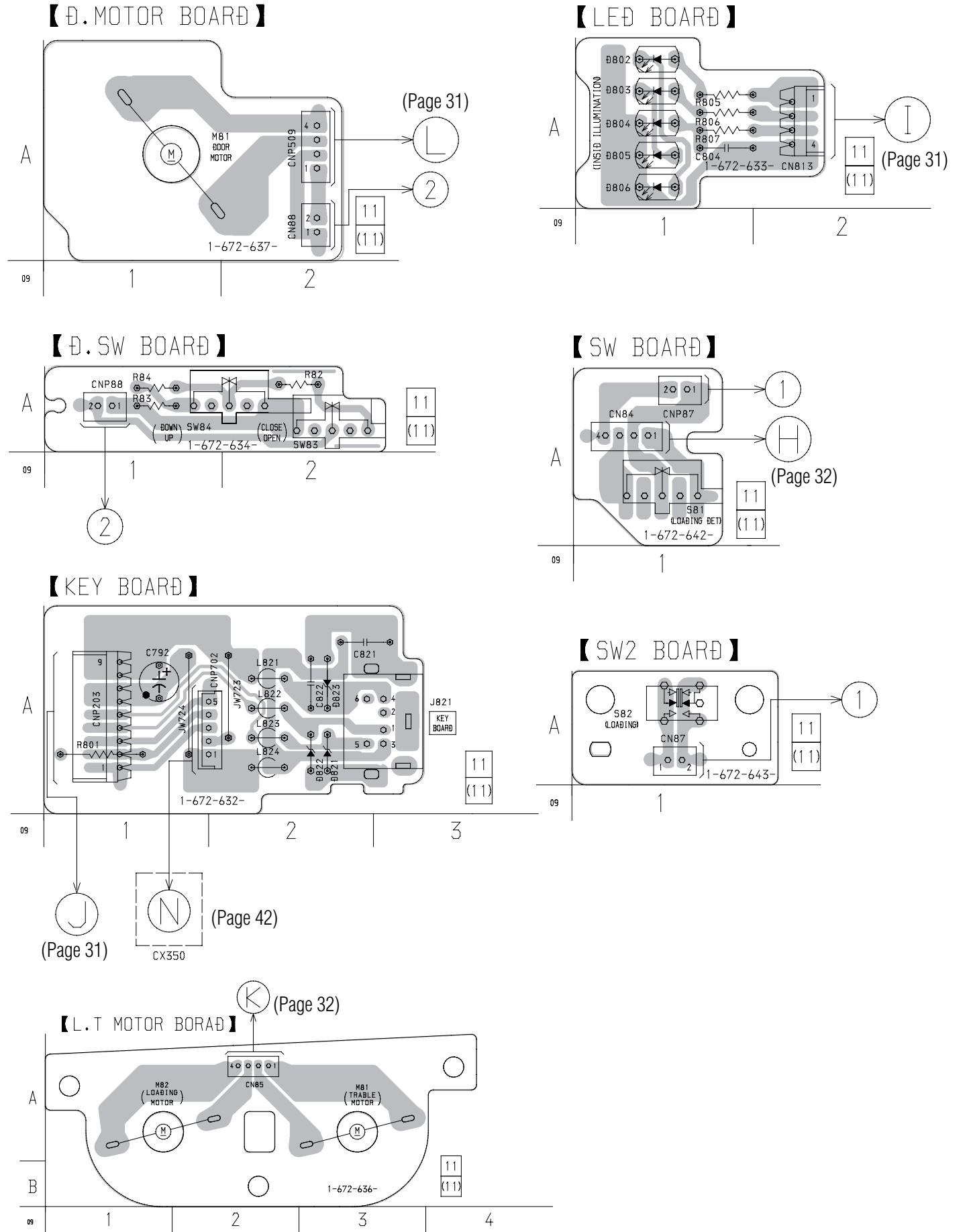

7-22. IC BLOCK DIAGRAMS

• BD section

IC101 CXD2587Q

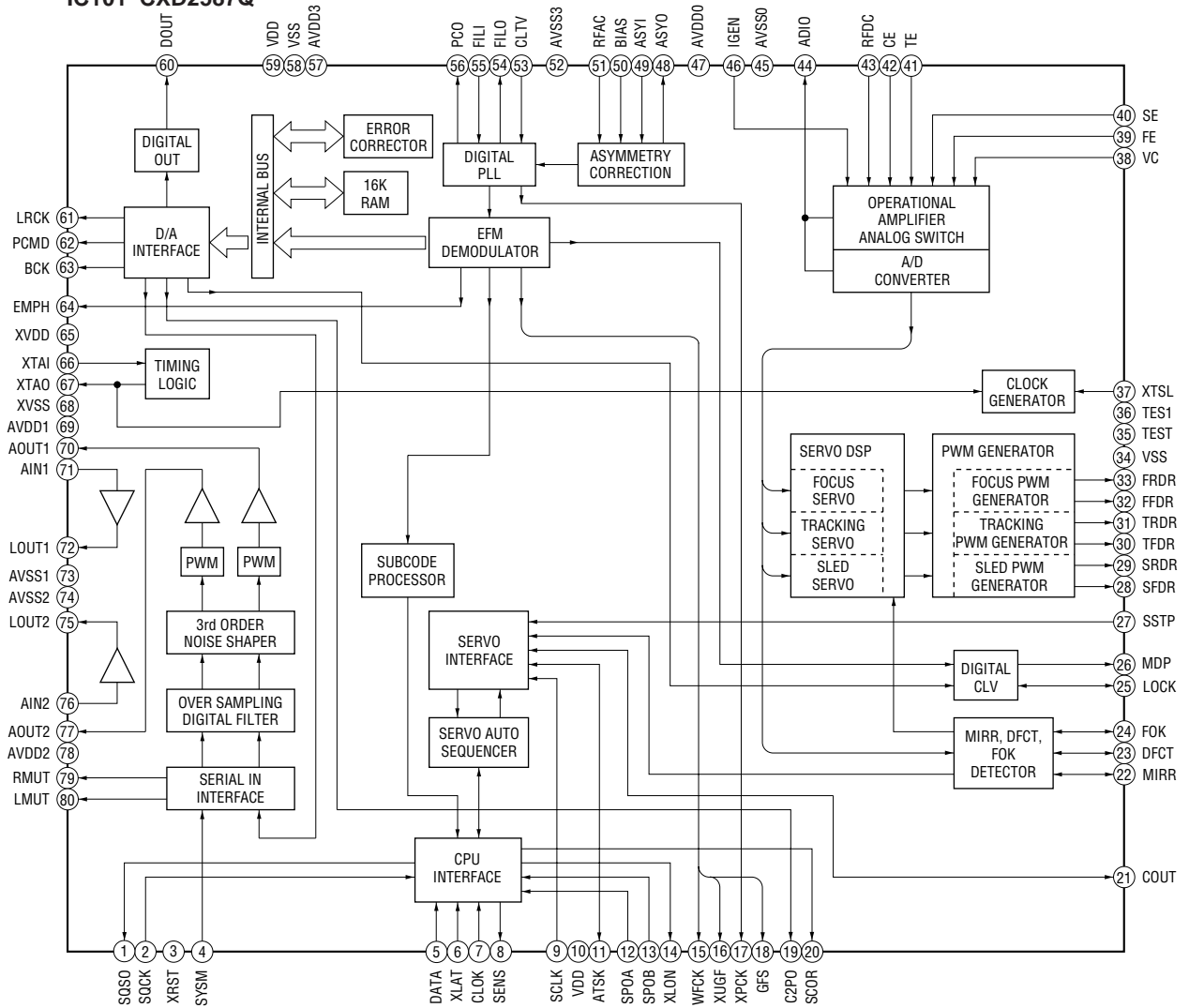

IC102 BA6392FP-E2

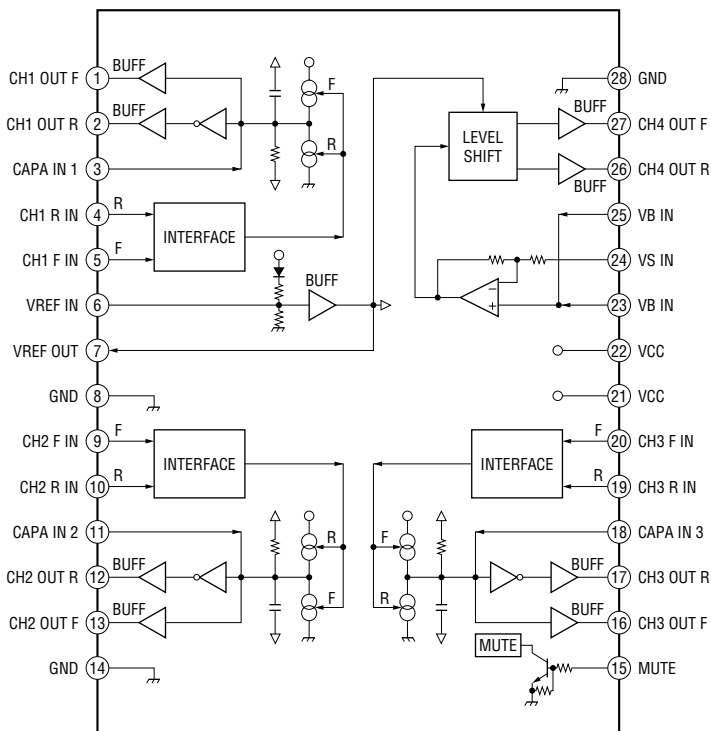

IC103 CXA2568M-T6

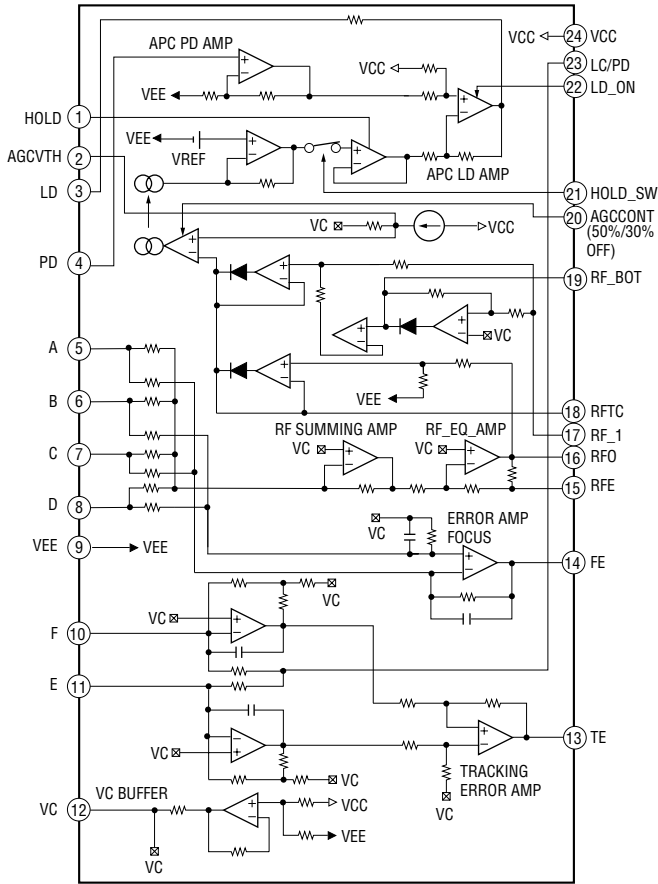

• **Main section**

IC504 M5M5256DFP-70XL

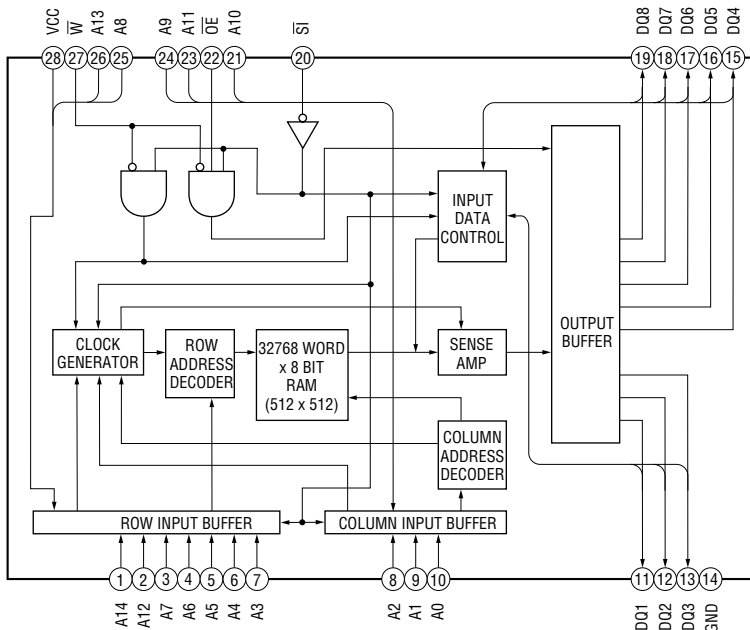

IC505 LA6510

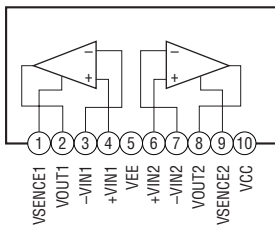

IC931 LA5601

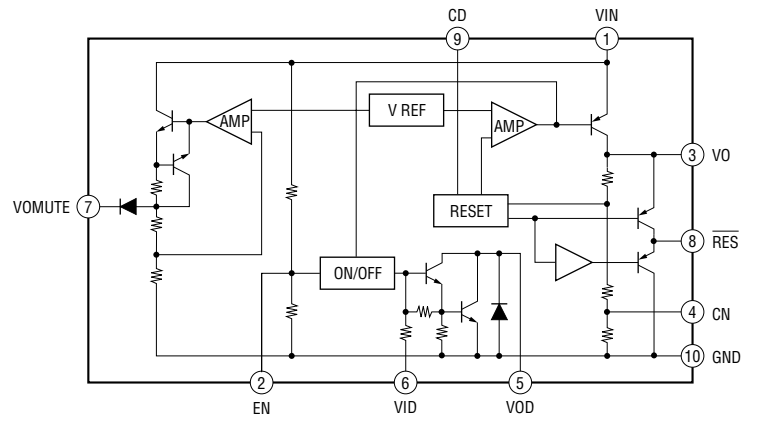

• Display section

IC702 M66310FP

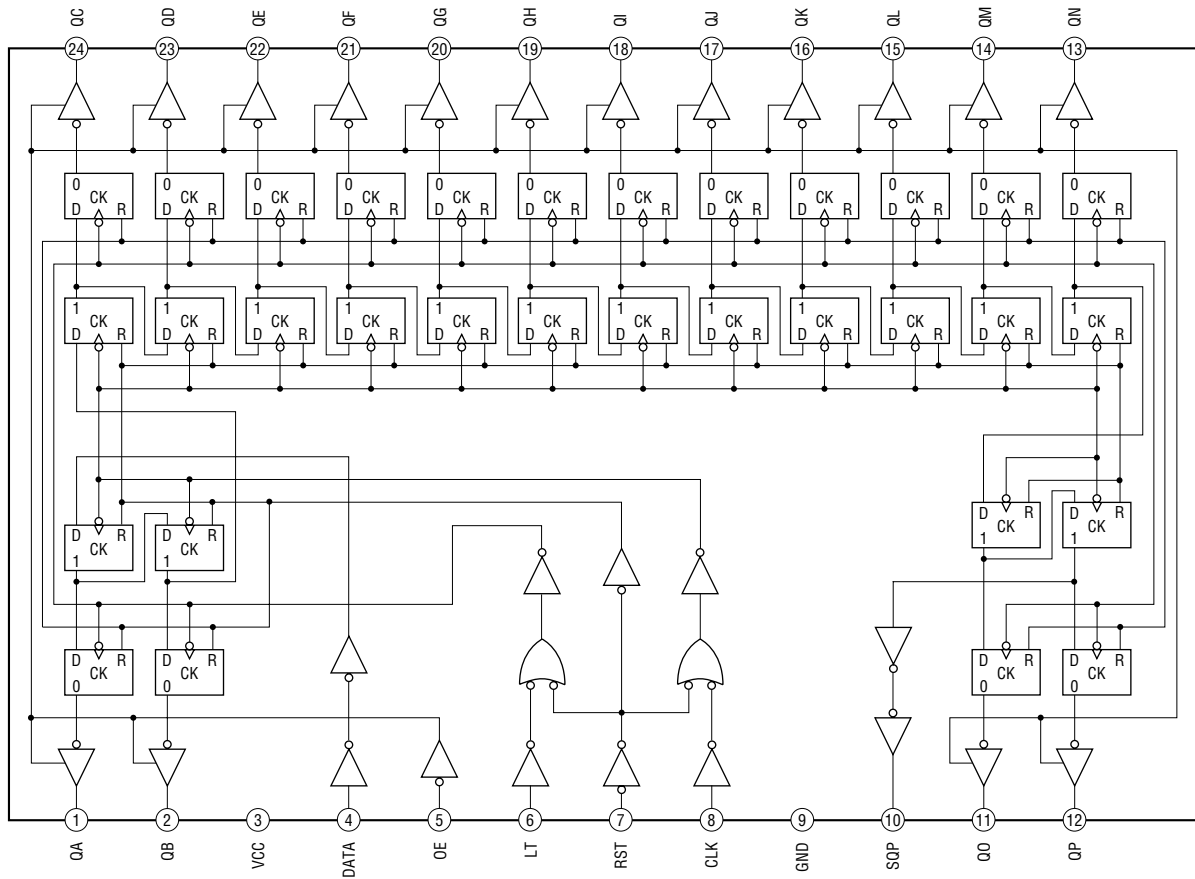

7-23. IC PIN FUNCTIONS

• IC101 DIGITAL SIGNAL PROCESSOR (CXD2587Q) (BD board)

Pin No.	Pin Name	I/O	Function
1	SQSO	O	Sub-Q 80-bit and PCM peak level data output (CD text data output)
2	SQCK	I	Clock input for SQSO read-out
3	XRST	I	System reset "L" : reset
4	SYSM	I	Muting input "H" : mute
5	DATA	I	Serial data input, supplied from CPU
6	XLAT	I	Latch input, supplied from CPU
7	CLOK	I	Serial data transfer clock input, supplied from CPU
8	SENS	O	SENS signal output to CPU
9	SCLK	I	SENS serial data read-out clock input
10	VDD	–	Digital power supply
11	ATSK	I/O	Input pin for anti-shock (Connected to ground)
12	SPOA	I	Microcomputer escape interface input A
13	SPOB	I	Microcomputer escape interface input B
14	XLON	O	Microcomputer escape interface output
15	WFCK	O	WFCK output (Not used)
16	XUGF	O	Not used
17	XPCK	O	Not used
18	GFS	O	Not used
19	C2PO	O	Not used
20	SCOR	O	Sub-code sync output
21	COUT	I/O	Numbers of track counted signal input/output (Not used)
22	MIRR	I/O	Mirror signal input/output (Not used)
23	DFCT	I/O	Defect signal input/output (Not used)
24	FOK	I/O	Focus OK input/output (Not used)
25	LOCK	I/O	GFS is sampled by 460 Hz. H when GFS is H (Not used)
26	MDP	O	Output to control spindle motor servo
27	SSTP	I	Input signal to detect disc inner most track
28	SFDR	O	Sled drive output
29	SRDR	O	Sled drive output
30	TFDR	O	Tracking drive output
31	TRDR	O	Tracking drive output
32	FFDR	O	Focus drive output
33	FRDR	O	Focus drive output
34	VSS	–	Digital ground
35	TEST	I	TEST pin connected normally to ground
36	TES1	I	TEST pin connected normally to ground
37	XTSL	I	X'tal selection input (Connected to ground)
38	VC	I	Center voltage input pin
39	FE	I	Focus error signal input
40	SE	I	Sled error signal input

- Abbreviation
GFS : Guarded Frame Sync

Pin No.	Pin Name	I/O	Function
41	TE	I	Tracking error signal input
42	CE	I	Center servo analog input
43	RFDC	I	RF signal input
44	ADIO	O	Test pin (Not used)
45	AVSS0	–	Analog ground
46	IGEN	I	Stabilized current input for operational amplifiers
47	AVDD0	–	Analog power supply
48	ASYO	O	EFM full swing output
49	ASYI	I	Asymmetry compare voltage input
50	BIAS	I	Asymmetry circuit constant current input
51	RFAC	I	EFM signal input
52	AVSS3	–	Analog ground
53	CLTV	I	Control voltage input for master VCO1
54	FILO	O	Filter output for master PLL
55	FILI	I	Filter input for master PLL
56	PCO	O	Charge-pump output for master PLL
57	AVDD3	–	Analog power supply
58	VSS	–	Digital ground
59	VDD	–	Digital power supply
60	DOUT	O	Digital-out output pin
61	LRCK	O	D/A interface LR clock output ($f = F_s$) (Not used)
62	PCMD	O	D/A interface serial data output (Not used)
63	BCK	O	D/A interface bit clock output (Not used)
64	EMPH	O	Playback disc output in emphasis mode (Not used)
65	XVDD	–	Power supply for master clock
66	XTAI	I	X'tal oscillator circuit input (16.9344MHz)
67	XTAO	O	X'tal oscillator circuit output (16.9344MHz)
68	XVSS	–	Ground for master clock
69	AVDD1	–	Analog power supply
70	AOUT1	O	L-ch analog output
71	AIN1	I	L-ch operational amplifiers input
72	LOUT1	O	L-ch line output
73	AVSS1	–	Analog ground
74	AVSS2	–	Analog ground
75	LOUT2	O	R-ch line output
76	AIN2	I	R-ch operational amplifiers input
77	AOUT2	O	R-ch analog output
78	AVDD2	–	Analog power supply
79	RMUT	O	R-ch “0” detection flag output
80	LMUT	O	L-ch “0” detection flag output

- Abbreviation
EFM : Eight to Fourteen Modulation
PLL : Phase Locked Loop

• IC501 SYSTEM CONTROL (MN101C12G-SA) (MAIN board)

Pin No.	Pin Name	I/O	Function
1	GND	—	Ground
2	DOOR SW	I	Door panel SW (5V: OPEN)
3	FILTER SW	I	D-F mode change SW
4	KEY1	I	Key A/D input
5	KEY2	I	
6	KEY3	I	
7	KEY4	I	
8	KEY5	I	
9	D.SENS	—	Disc sensor input
10	VREF	—	A/D standard power terminal
11	VDD	—	Connect to +5V
12	X'TAL OSC1	—	X'tal Oscillation (10MHz) Output
13	X'TAL OSC2	—	X'tal Oscillation (10MHz) Input
14	VSS	—	Connect to ground
15	X1	—	Not used
16	X0	—	Not used
17	GND	—	Ground
18	AC IN	I	Power monitor input
19	ICSW (RELAY ON/OFF)	O	Power terminal for circumference IC
20	LEDLT	O	Latch for LED driver output
21	FLDATA	O	Data for fluorescent indicator driver output
22	FLLT	O	Latch for fluorescent indicator output
23	FLCLK	O	Clock for fluorescent indicator output
24	RESET OUT	O	Reset output for circumference IC
25	STANDBY-LED	O	LED output for STANDBY
26	RMIN	I	Remote control input
27	T2	I	Table sensor input
28	T4	I	
29	BUSIN	I	CONTROL A1 input
30	SCOR	I	Sub code Q synchronous signal
31	KBCIN	I	Keyboard clock input
32	T1	I	Table sensor input
33	RESET	I	System reset signal input
34	KBCOUT	O	Keyboard clock output
35	KBDOUT	O	Keyboard data output
36	KBDIN	I	Keyboard data input
37	TEST-PULSE2	—	DISC detection test output
38	TEST PULSE	O	TSENS1, 2 AND output
39	AGC	O	CXD2587 LPH output
40	SMUTE	O	Mute output ON
41	AMUTE	I	Mute output ON
42	DATA	O	CXD2587 D/F data output
43	XLT	O	CXD2587 Latch output
44	CLK	O	CXD2587 D/F clock output
45	SENS	I	CXD2587 Servo sensor signal input
46	SUBQ	I	CXD2587 Q data input
47	SQCK	O	CXD2587 Q data clock output
48	LED3	O	interior illumination
49	LED2	O	interior illumination

Pin No.	Pin Name	I/O	Function
50	LED1	O	interior illumination
51	SELECT	I	CX691 select port (H: CX691 L: Other)
52	T3	I	Table sensor input
53	SELECT	I	J select port (H: J L: Other)
54	SELECT	I	ES select port (H: ES L: HiFi) (Fix at L)
55	SELECT	I	2WAY select port (H: 2WAY L: ONE WAY)
56	2WAY-LT	O	U-COM chip enable output
57	CX5/CX6	O	CXD8735 Latch output
58	CX3/CX4	O	Not used
59	2WAYLT	O	Reset output
60	AFADJ	I	AFADJ select port
61	ADJ	I	ADJ mode select port
62	WE	O	SRAM write enable output
63	A13	O	SRAM address output
64	A8	O	
65	A9	O	
66	A10	O	
67	A11	O	
68	A14	O	
69	A12	O	
70	A7	O	
71	A6	O	
72	A5	O	
73	A4	O	
74	A3	O	
75	A2	O	
76	A1	O	
77	A0	O	
78	CS	O	SRAM chip select output
79	D2	I/O	SRAM data input/output
80	D1	I/O	
81	D0	I/O	
82	D3	I/O	
83	D4	I/O	
84	D5	I/O	
85	D6	I/O	
86	D7	I/O	
87	BUSOUT	O	CONTROL-A1 output
88	CD2	I	Remote control mode select input (CDP2)
89	CD3	I	Remote control mode select input (CDP3)
90	SW	I	Table close switch
91	INSW	I	Loading in switch
92	OUTSW	I	Loading out switch
93	DOOROUT	—	Door open output
94	DOORIN	—	Door close output
95	GND	—	Ground
96	LDOUT	O	Loading motor PWM output for outside direction
97	LDIN	O	Loading motor PWM output for inside direction
98	TBLR	O	Table motor PWM output for right turn
99	TBLL	O	Table motor PWM output for left turn
100	DVDD	—	D/A converter standard power terminal

SECTION 8 EXPLODED VIEWS

NOTE:

- -XX, -X mean standardized parts, so they may have some difference from the original one.
- Items marked “*” are not stocked since they are seldom required for routine service. Some delay should be anticipated when ordering these items.
- Color Indication of Appearance Parts Example:
KNOB, BALANCE (WHITE) (RED)

↑ ↑
Parts color Cabinets color

- The mechanical parts with no reference number in the exploded views are not supplied.
- Hardware (# mark) list and accessories and packing materials are given in the last of this parts list.
- Abbreviation
CND : Canadian model
AUS : Australian model

The components identified by mark \triangle or dotted line with mark \triangle are critical for safety. Replace only with part number specified.

Les composants identifiés par une marque \triangle sont critiques pour la sécurité. Ne les remplacer que par une pièce portant le numéro spécifié.

8-1. CASE SECTION

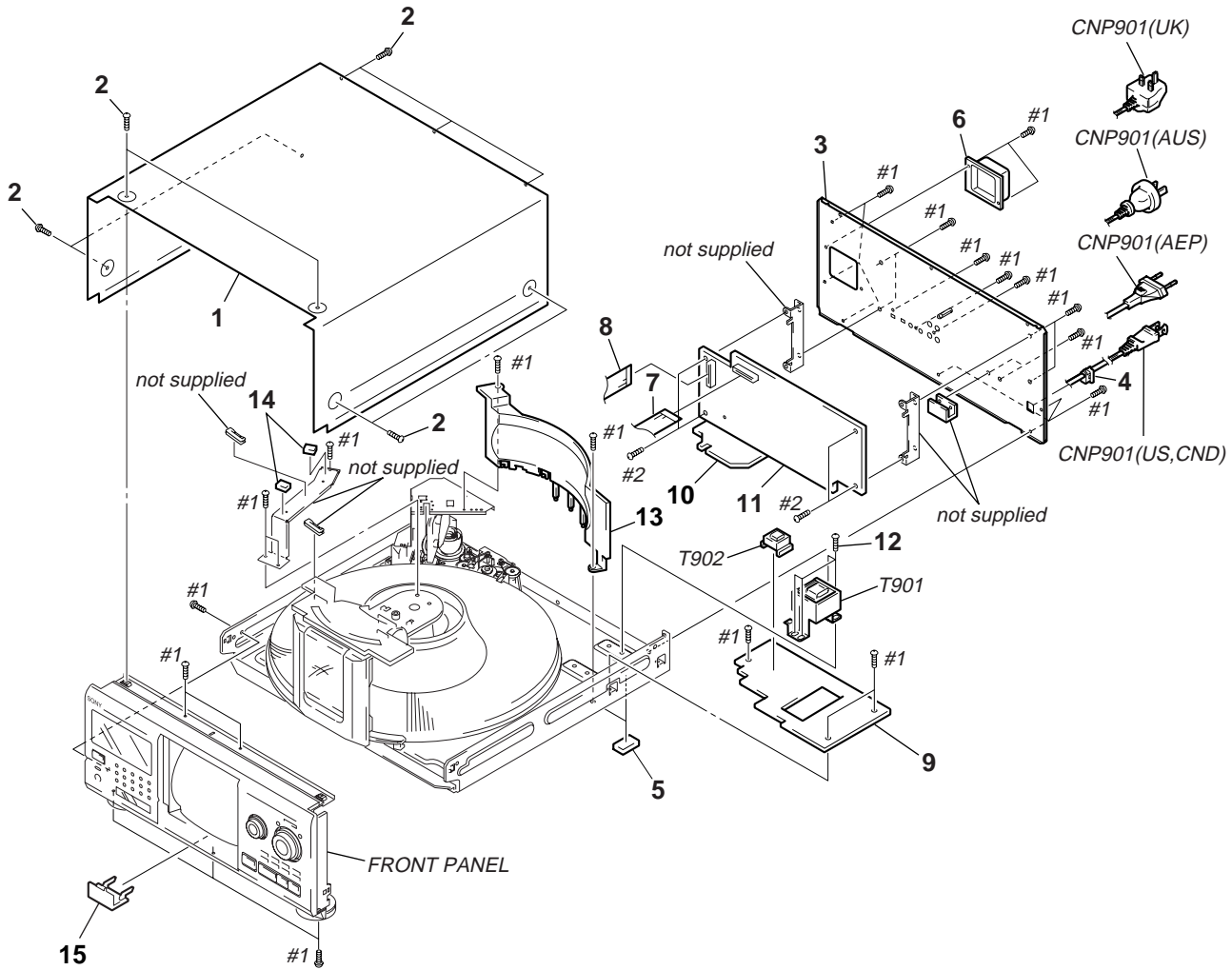

Ref. No.	Part No.	Description	Remark	Ref. No.	Part No.	Description	Remark
1	4-215-970-11	CASE		11	A-4724-560-A	MAIN BOARD, COMPLETE (CX350:AEP,UK,AUS)	
2	4-210-291-01	SCREW (CASE 3 TP2) (CX300/CX350)		11	A-4724-567-A	MAIN BOARD, COMPLETE (CX300/CX691)	
3	4-215-964-01	PANEL, BACK (CX300:US)		12	4-886-821-11	SCREW, S TIGHT, +PTTWH3X6	
3	4-215-964-11	PANEL, BACK (CX300:CND)		13	4-215-967-01	COVER (P.T.)	
3	4-215-964-21	PANEL, BACK (CX350:US)		14	4-985-553-11	CUSHION	
3	4-215-964-31	PANEL, BACK (CX350:CND)		15	4-215-960-01	COVER (CHASSIS)	
3	4-215-964-41	PANEL, BACK (CX350:AEP,UK)		\triangle CNP901	1-575-651-21	CORD, POWER (CX350:AEP)	
3	4-215-964-51	PANEL, BACK (CX350:AUS)		\triangle CNP901	1-696-845-11	CORD, POWER (CX350:AUS)	
3	4-215-964-71	PANEL, BACK (CX691)		\triangle CNP901	1-751-529-11	CORD, POWER (CX350:UK)	
* 4	3-703-244-00	BUSHING (2104), CORD		\triangle CNP901	1-783-531-41	CORD, POWER (CX300/CX350:US,CND/CX691)	
5	4-215-971-01	CUSHION (FOOT)		\triangle T901	1-433-666-11	TRANSFORMER, POWER (CX300/CX350:US,CND/CX691)	
* 6	4-982-807-01	COVER (FFC)		\triangle T901	1-433-668-11	TRANSFORMER, POWER (CX350:AEP,UK)	
7	1-790-420-11	WIRE (FLAT TYPE) (21 CORE)		\triangle T901	1-433-877-11	TRANSFORMER, POWER (CX350:AUS)	
8	1-773-183-11	WIRE (FLAT TYPE) (23 CORE)		\triangle T902	1-433-663-11	TRANSFORMER, POWER (CX300/CX350:US,CND/CX691)	
9	1-672-638-11	POWER BOARD		\triangle T902	1-433-665-11	TRANSFORMER, POWER (CX350:AEP,UK,AUS)	
10	1-672-629-11	JACK BOARD					
11	A-4724-557-A	MAIN BOARD, COMPLETE (CX350:US,CND)					

8-2. CHASSIS SECTION

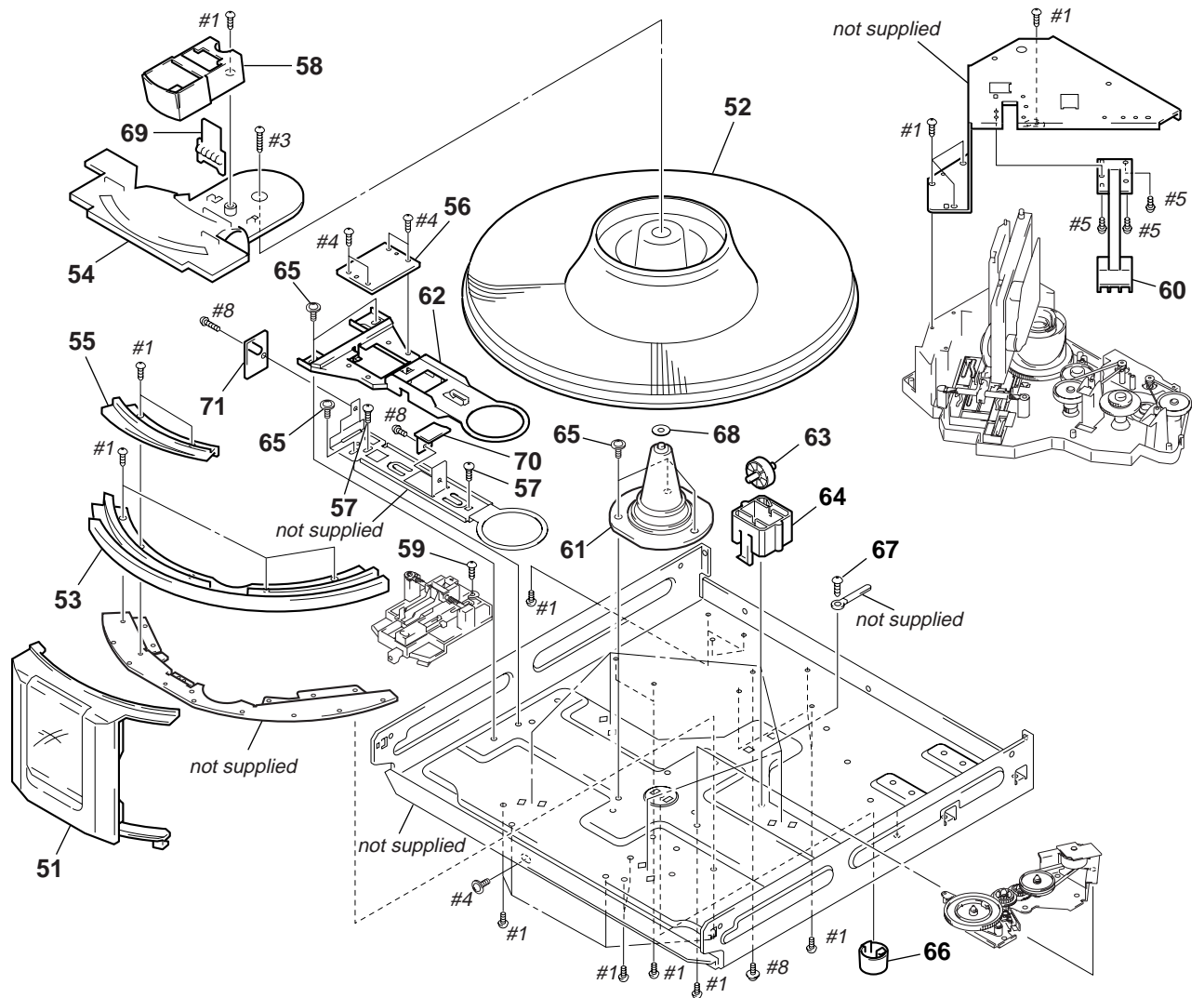

Ref. No.	Part No.	Description	Remark	Ref. No.	Part No.	Description	Remark
51	X-4950-889-1	DOOR (CD) ASSY		62	4-216-091-01	HOLDER (TABLE SENSOR)	
52	X-4950-902-1	TABLE (300) ASSY		63	4-216-092-01	HOLDER (ROLLER)	
53	4-215-952-01	GUIDE (DOOR.B)		64	4-216-093-01	ROLLER	
54	4-215-953-01	GUIDE (DOOR.T)		65	4-886-821-11	SCREW, S TIGHT, +PTTWH 3X6	
55	4-215-954-01	COVER (FRONT)		66	4-931-169-01	FOOT	
56	1-672-639-11	T.SENS BOARD		67	3-970-608-01	SUMITITE (B3), +BV	
57	4-216-096-01	SCREW (T1), STEP		68	3-701-447-21	WASHER, 10	
58	4-215-968-01	WINDOW (INTERNAL ILLUMINATION)		69	1-672-633-11	LED BOARD	
59	3-356-601-11	SCREW, STEP		70	1-672-640-11	D.SENS (IN) BOARD	
60	4-216-088-01	GUIDE (DISC)		71	1-672-641-11	D.SENS (OUT) BOARD	
61	4-216-089-01	SHAFT (CENTER)					

8-3. FRONT PANEL SECTION

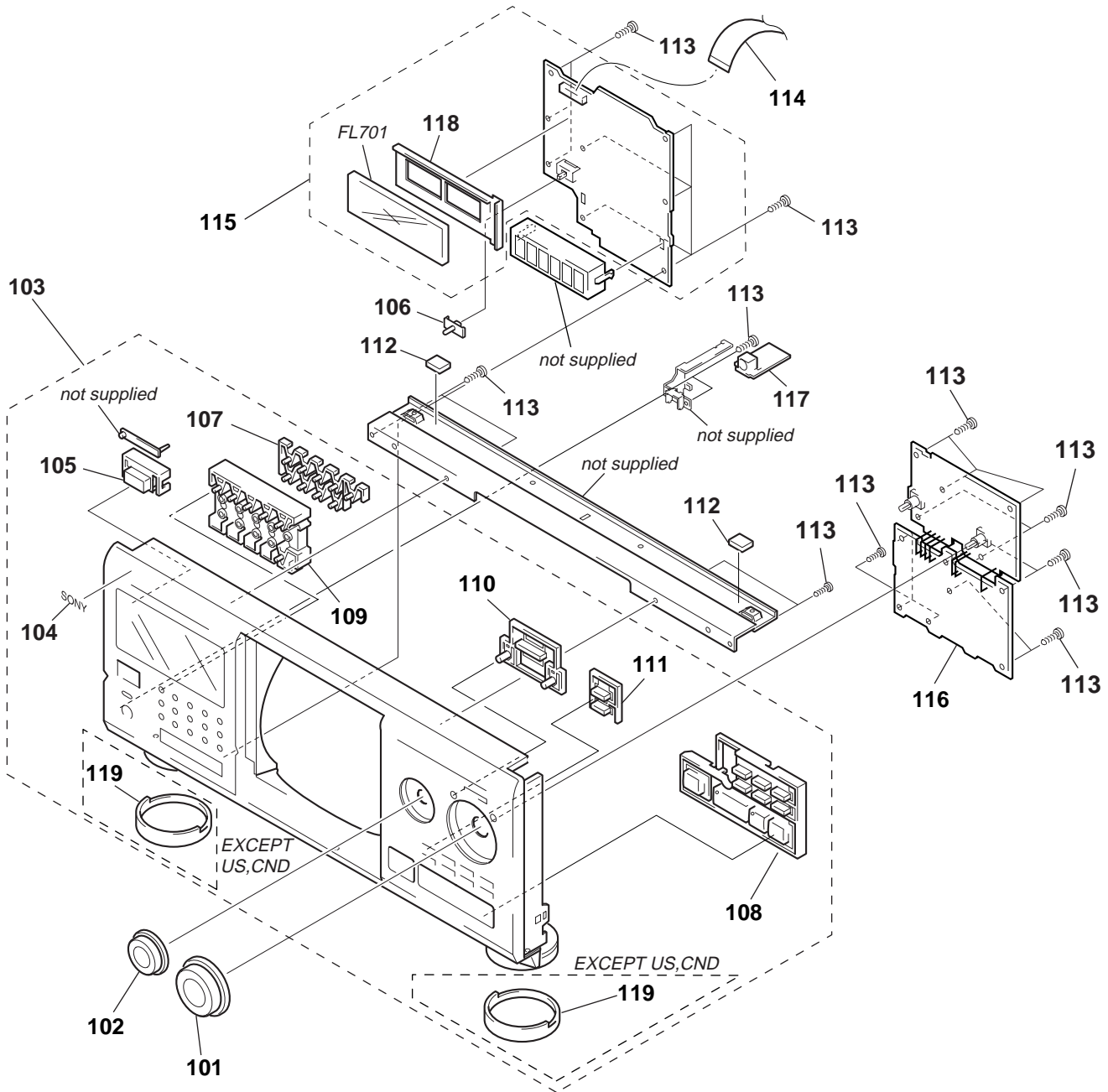

Ref. No.	Part No.	Description	Remark	Ref. No.	Part No.	Description	Remark
101	4-215-818-01	KNOB (DISC)		111	4-215-814-01	BUTTON (MEGA-CON)	
102	4-215-819-01	KNOB (AMS)		112	4-985-553-21	CUSHION	
103	X-4950-855-1	PANEL ASSY, FRONT (CX300)		113	4-951-620-01	SCREW (2.6X8), +BVTP	
103	X-4950-857-1	PANEL ASSY, FRONT (CX350:US,CND)		114	1-790-420-11	WIRE (FLAT TYPE) (21 CORE)	
103	X-4950-858-1	PANEL ASSY, FRONT (CX350:AEP,UK,AUS)		115	A-4724-546-A	DISPLAY BOARD, COMPLETE (CX350)	
103	X-4950-917-1	PANEL ASSY, FRONT (CX691)		115	A-4724-566-A	DISPLAY BOARD, COMPLETE (CX300/CX691)	
104	4-996-698-01	EMBLEM, SONY		116	A-4724-545-A	JOG BOARD, COMPLETE (CX350)	
105	4-215-928-01	BUTTON (POWER)		116	A-4724-565-A	JOG BOARD, COMPLETE (CX300/CX691)	
106	3-917-216-21	KNOB (TIMER)		117	1-672-632-11	KEY BOARD	
107	4-215-816-01	BUTTON (GROUP)		118	4-982-811-11	HOLDER (FL)	
108	X-4950-856-1	BUTTON (PLAY) ASSY		119	4-219-323-01	RING (DIA. 50) (EXCEPT US, CND)	
109	4-215-815-01	BUTTON (MODE)		FL701	1-517-861-11	INDICATOR TUBE, FLUORESCENT	
110	4-215-817-01	BUTTON (MENU)					

8-4. MECHANISM SECTION 1 (CDM54-K1BD35E)

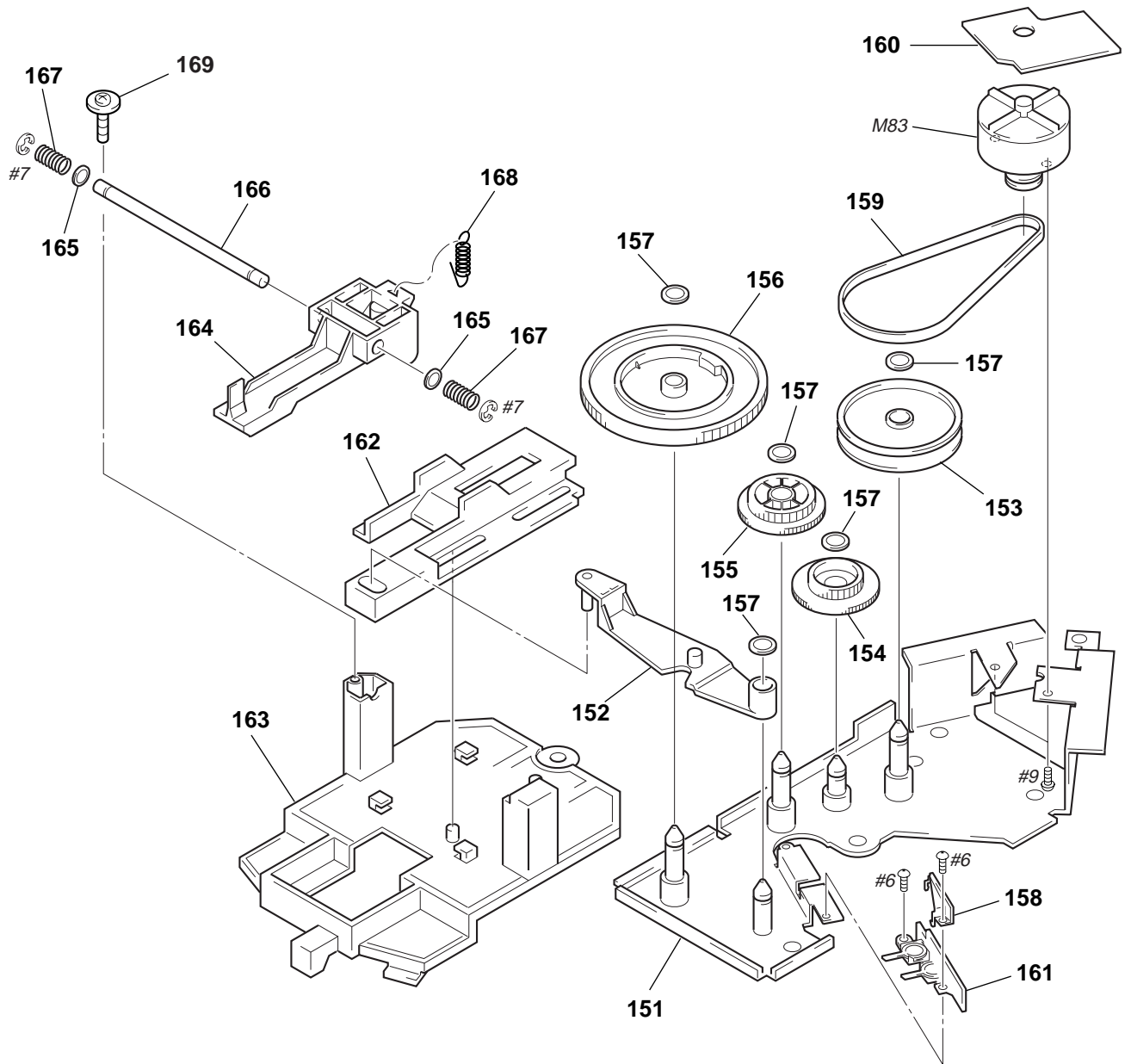

Ref. No.	Part No.	Description	Remark	Ref. No.	Part No.	Description	Remark
151	X-4950-888-1	BRACKET (DOOR.GEAR) ASSY		161	1-672-634-11	D.SW (A) BOARD	
152	4-215-959-01	LEVER (CAM.PU)		162	4-216-099-01	SLIDER (POP-UP)	
153	4-215-955-01	GEAR (DOOR.PULLEY)		163	4-216-100-01	HOLDER (POP-UP)	
154	4-215-956-01	GEAR (DOOR.CENTER)		164	4-216-098-01	LEVER (POP-UP)	
155	4-215-957-01	GEAR (DOOR.DRIVE)		165	3-701-441-21	WASHER	
156	4-215-958-01	GEAR (DOOR.CAM)		166	4-216-102-01	SHAFT (POP-UP FULCRUM)	
157	3-325-697-21	WASHER		167	4-216-103-01	SPRING (POP-UP), COMPRESSION	
158	4-219-324-01	HOLDER (L-SW)		168	4-216-104-01	SPRING (POP-UP), TENSION	
159	4-219-326-01	BELT (DIA. 42X1.2)		169	4-998-716-01	SCREW, BU FITTING	
160	1-672-637-11	D.MOTOR BOARD		M83	X-4950-062-1	DOOR MOTOR	

8-5. MECHANISM SECTION 2 (CDM54-K1BD35E)

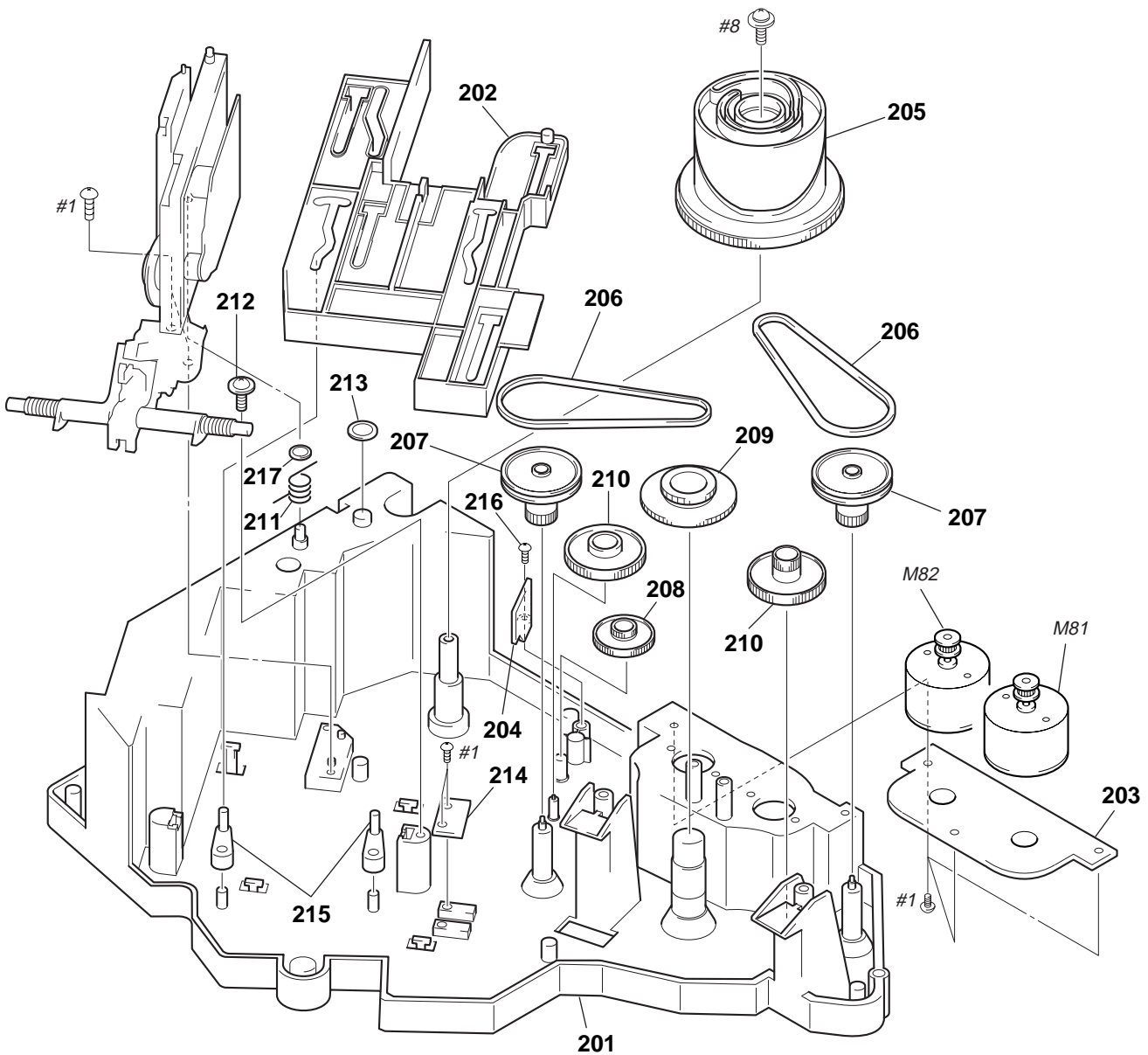

<u>Ref. No.</u>	<u>Part No.</u>	<u>Description</u>	<u>Remark</u>	<u>Ref. No.</u>	<u>Part No.</u>	<u>Description</u>	<u>Remark</u>
201	4-216-054-01	BASE (CDM)		211	4-216-081-01	SPRING (MG), TORSION	
202	4-216-063-01	SLIDER		212	4-998-716-01	SCREW, BU FITTING	
203	1-672-636-11	L.T.MOTOR BOARD		213	3-701-446-21	WASHER, 8	
204	1-672-642-11	SW BOARD		214	1-672-643-11	SW2 BOARD	
205	A-4672-676-A	CAM ASSY		215	4-216-062-01	LEVER (FULCRUM)	
206	4-216-061-01	BELT		216	4-951-620-01	SCREW (2.6X8), +BVTP	
207	4-216-060-01	PULLEY (1)		217	3-701-441-21	WASHER	
208	4-216-057-01	GEAR (CENTER 2)		M81	A-4672-675-A	MOTOR ASSY (TABLE)	
209	4-216-059-01	GEAR (TABLE)		M82	A-4672-675-A	MOTOR ASSY (LOADING)	
210	4-216-058-01	GEAR (CENTER)					

8-6. MECHANISM SECTION 3 (CDM54-K1BD35E)

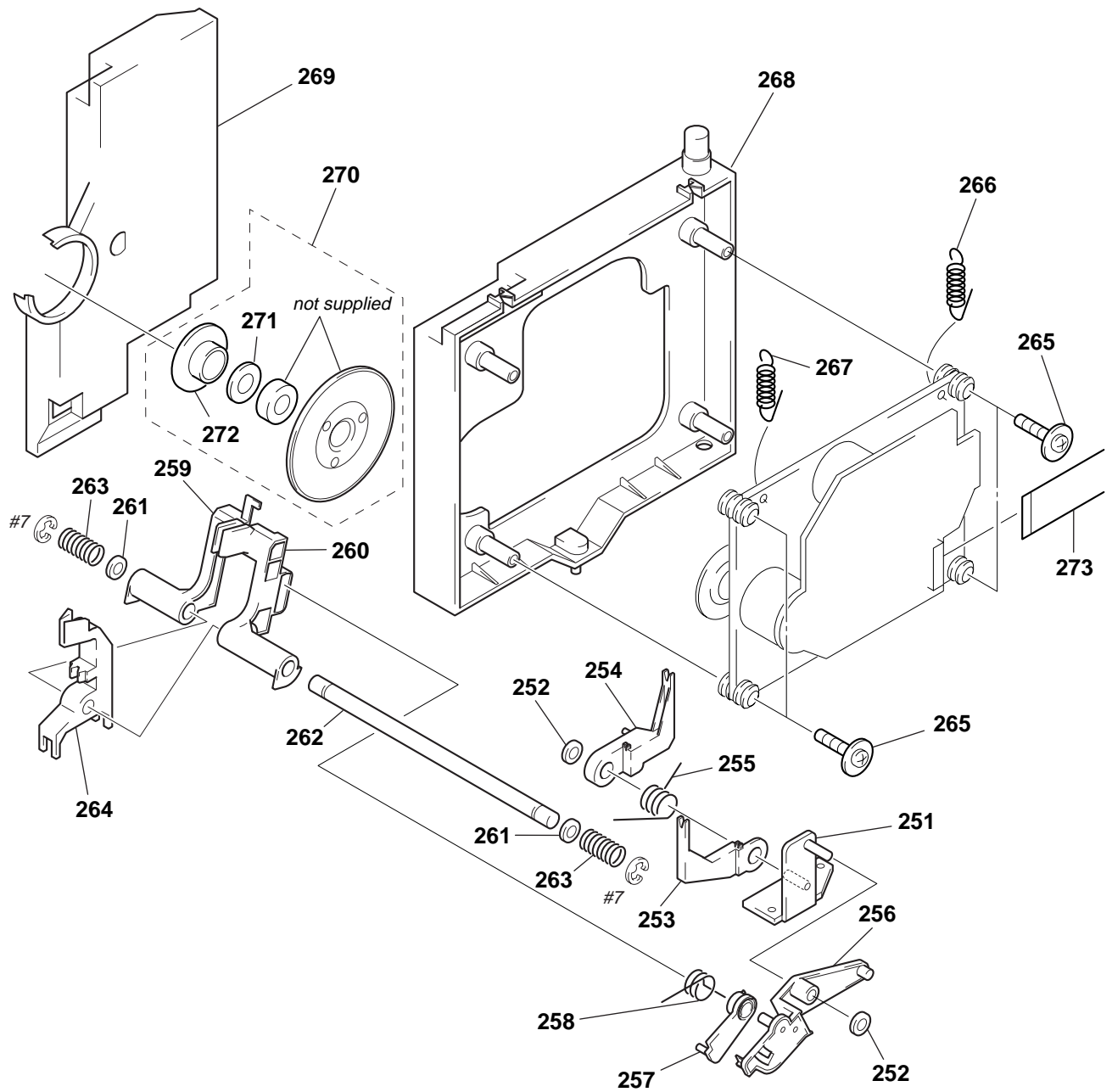

Ref. No.	Part No.	Description	Remark	Ref. No.	Part No.	Description	Remark
251	X-4950-900-1	BRACKET (LEVER) ASSY		263	4-216-067-01	SPRING (CLAMP), COMPRESSION	
252	3-325-697-21	WASHER		264	4-216-070-01	LEVER (LOCK)	
253	4-216-075-01	HOLDER (F)		265	4-957-577-01	SCREW PTP WH (2.6X8) (DIA. 10)	
254	4-216-076-01	HOLDER (R)					
255	4-216-077-01	SPRING (HOLDER FR), TORSION		266	4-216-086-01	SPRING (F-2), TENSION	
256	4-216-078-01	LEVER (LOADING)		267	4-216-085-01	SPRING (F-1), TENSION	
257	4-216-079-01	LIMITTER (LEVER)		268	X-4950-901-1	HOLDER ASSY, BU	
258	4-216-080-01	SPRING (LIMITTER), TORSION		269	4-216-082-01	HOLDER (MAGNET), TORSION	
259	X-4950-885-1	HOLDER (DISC L) ASSY		270	A-4672-768-A	MAGNET ASSY	
260	X-4950-886-1	HOLDER (DISC R) ASSY		271	4-960-633-11	YOKE (MAGNET)	
261	3-701-441-21	WASHER		272	4-999-139-02	PULLEY (B)	
262	4-216-066-01	SHAFT (CLAMP)		273	1-769-069-11	WIRE (FLAT TYPE) (16 CORE)	

8-7. OPTICAL PICK-UP SECTION (KSM-213BFN/M-NP)

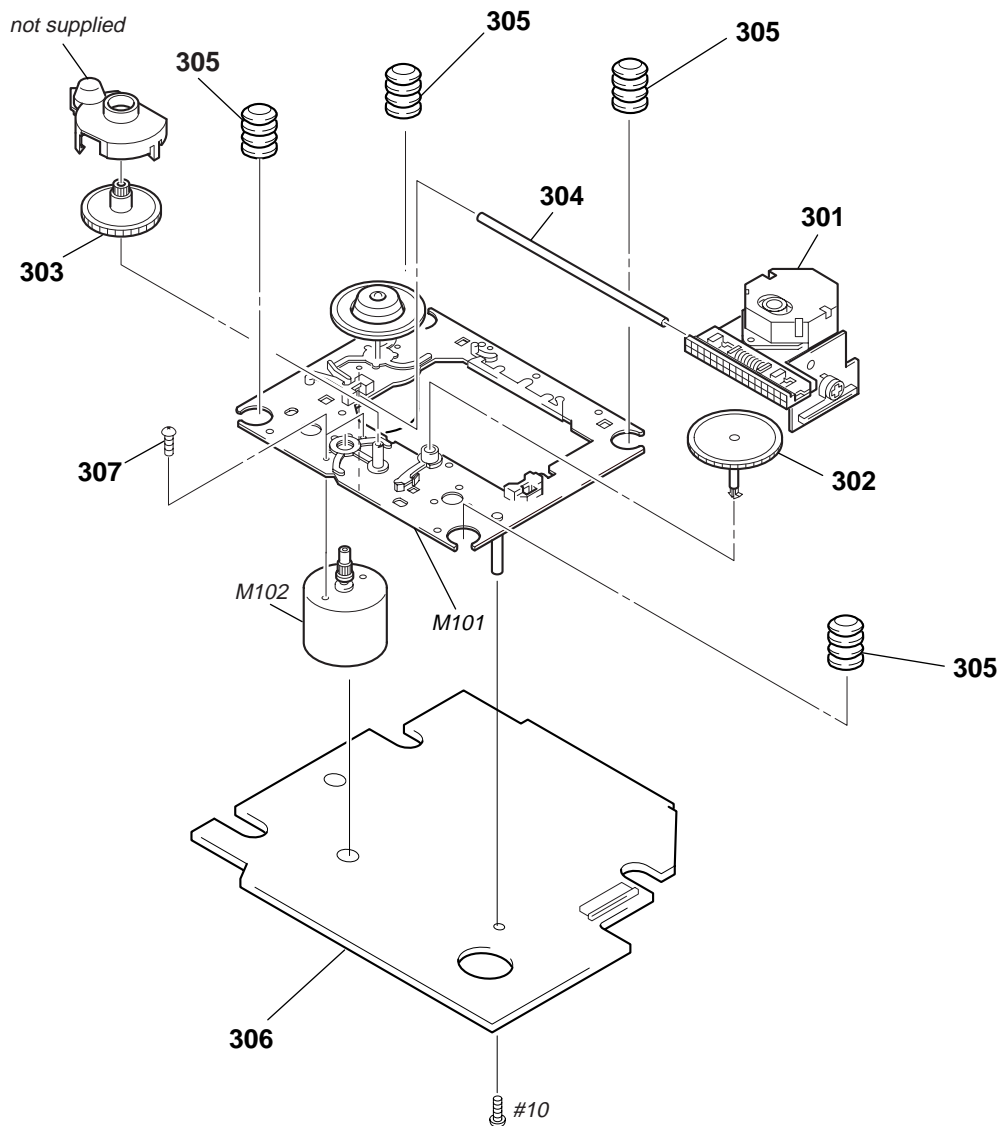

<p>The components identified by mark \triangle or dotted line with mark \triangle are critical for safety. Replace only with part number specified.</p>	<p>Les composants identifiés par une marque \triangle sont critiques pour la sécurité. Ne les remplacer que par une pièce portant le numéro spécifié.</p>
---	--

Ref. No.	Part No.	Description	Remark	Ref. No.	Part No.	Description	Remark
\triangle 301	8-848-379-31	OPTICAL PICK-UP KSS-213B/S-N		* 306	A-4724-761-A	BD BOARD, COMPLETE	
302	2-626-907-01	GEAR (A)(S)		307	3-713-786-51	SCREW +P2X3	
303	2-627-003-02	GEAR (B)(RP)		M101	X-2646-110-3	T.T CHASSIS ASSY (MB)(F)(SPINDLE)	
304	2-626-908-01	SHAFT, SLED		M102	X-2625-769-1	MOTOR GEAR ASSY (MB)(RP)(SLED)	
* 305	4-992-054-01	RUBBER, VIBRATION PROOF					

SECTION 9 ELECTRICAL PARTS LIST

BD

Note:

The components identified by mark Δ or dotted line with mark Δ are critical for safety. Replace only with part number specified.

Les composants identifiés par une marque Δ sont critiques pour la sécurité. Ne les remplacer que par une pièce portant le numéro spécifié.

When indicating parts by reference number, please include the board name.

- Due to standardization, replacements in the parts list may be different from the parts specified in the diagrams or the components used on the set.
- -XX, -X mean standardized parts, so they may have some difference from the original one.
- Items marked "*" are not stocked since they are seldom required for routine service. Some delay should be anticipated when ordering these items.
- RESISTORS
All resistors are in ohms
METAL: Metal-film resistor
METAL OXIDE: Metal Oxide-film resistor
F : nonflammable
- SEMICONDUCTORS
In each case, u: μ , for example:
uA...: μ A..., uPA...: μ PA..., uPB...: μ PB...,
uPC...: μ PC..., uPD...: μ PD...
- CAPACITORS
uF : μ F
- COILS
uH : μ H
- Abbreviation
CND : Canadian model
AUS : Australian model

Ref. No.	Part No.	Description	Remark	Ref. No.	Part No.	Description	Remark
*	A-4724-761-A	BD BOARD, COMPLETE *****		C167	1-163-235-11	CERAMIC CHIP 22PF	5% 50V
		< CAPACITOR >		C168	1-163-237-11	CERAMIC CHIP 27PF	5% 50V
				C171	1-163-137-00	CERAMIC CHIP 680PF	5% 50V
C101	1-163-005-11	CERAMIC CHIP 470PF	10% 50V	C172	1-163-251-11	CERAMIC CHIP 100PF	5% 50V
C102	1-163-038-91	CERAMIC CHIP 0.1uF	25V	C181	1-163-137-00	CERAMIC CHIP 680PF	5% 50V
C103	1-163-005-11	CERAMIC CHIP 470PF	10% 50V	C182	1-163-251-11	CERAMIC CHIP 100PF	5% 50V
C104	1-163-021-91	CERAMIC CHIP 0.01uF	10% 50V			< CONNECTOR >	
C106	1-164-346-11	CERAMIC CHIP 1uF	16V	CN101	1-770-072-11	CONNECTOR,(LIF(NON-ZIF))FFC23P	
C107	1-164-346-11	CERAMIC CHIP 1uF	16V	CN102	1-777-937-11	CONNECTOR, FFC/FPC 16P	
C108	1-163-035-00	CERAMIC CHIP 0.047uF	50V			< IC >	
C109	1-163-145-00	CERAMIC CHIP 0.0015uF	5% 50V	IC101	8-752-386-85	IC CXD2587Q	
C110	1-163-017-00	CERAMIC CHIP 0.0047uF	5% 50V	IC102	8-759-455-91	IC BA6392FP-E2	
C111	1-163-251-11	CERAMIC CHIP 100PF	5% 50V	IC103	8-752-085-51	IC CXA2568M-T6	
C112	1-163-038-91	CERAMIC CHIP 0.1uF	25V			< COIL >	
C113	1-163-038-91	CERAMIC CHIP 0.1uF	25V	L101	1-414-234-22	INDUCTOR CHIP 0uH	
C114	1-163-038-91	CERAMIC CHIP 0.1uF	25V	L102	1-414-234-22	INDUCTOR CHIP 0uH	
C115	1-126-607-11	ELECT CHIP 47uF	20% 4V			< TRANSISTOR >	
C116	1-126-607-11	ELECT CHIP 47uF	20% 4V	Q101	8-729-010-08	TRANSISTOR MSB710-R	
C117	1-126-209-11	ELECT CHIP 100uF	20% 4V			< RESISTOR >	
C118	1-163-275-11	CERAMIC CHIP 0.001uF	5% 50V	R101	1-216-077-00	METAL CHIP 15K	5% 1/10W
C119	1-163-231-11	CERAMIC CHIP 15PF	5% 50V	R102	1-216-097-91	RES,CHIP 100K	5% 1/10W
C120	1-163-038-91	CERAMIC CHIP 0.1uF	25V	R103	1-216-077-00	METAL CHIP 15K	5% 1/10W
C121	1-163-038-91	CERAMIC CHIP 0.1uF	25V	R104	1-216-085-00	METAL CHIP 33K	5% 1/10W
C122	1-135-155-21	TANTALUM CHIP 4.7uF	10% 16V	R105	1-216-097-91	RES,CHIP 100K	5% 1/10W
C123	1-163-021-91	CERAMIC CHIP 0.01uF	10% 50V	R106	1-216-061-00	METAL CHIP 3.3K	5% 1/10W
C124	1-164-005-11	CERAMIC CHIP 0.47uF	25V	R107	1-216-061-00	METAL CHIP 3.3K	5% 1/10W
C125	1-163-038-91	CERAMIC CHIP 0.1uF	25V	R108	1-216-073-00	METAL CHIP 10K	5% 1/10W
C126	1-163-038-91	CERAMIC CHIP 0.1uF	25V	R109	1-216-121-91	RES,CHIP 1M	5% 1/10W
C127	1-109-982-11	CERAMIC CHIP 1uF	10% 10V	R110	1-216-025-91	RES,CHIP 100	5% 1/10W
C130	1-164-004-11	CERAMIC CHIP 0.1uF	10% 25V	R111	1-216-121-91	RES,CHIP 1M	5% 1/10W
C131	1-135-216-11	TANTALUM CHIP 10uF	20% 10V	R113	1-216-121-91	RES,CHIP 1M	5% 1/10W
C140	1-163-038-91	CERAMIC CHIP 0.1uF	25V	R116	1-216-025-91	RES,CHIP 100	5% 1/10W
C141	1-163-038-91	CERAMIC CHIP 0.1uF	25V	R117	1-216-049-91	RES,CHIP 1K	5% 1/10W
C151	1-163-237-11	CERAMIC CHIP 27PF	5% 50V	R119	1-216-043-91	RES,CHIP 560	5% 1/10W
C153	1-163-038-91	CERAMIC CHIP 0.1uF	25V	R123	1-216-073-00	METAL CHIP 10K	5% 1/10W
C154	1-164-336-11	CERAMIC CHIP 0.33uF	25V	R124	1-216-097-91	RES,CHIP 100K	5% 1/10W
C156	1-163-237-11	CERAMIC CHIP 27PF	5% 50V	R131	1-216-037-00	METAL CHIP 330	5% 1/10W
C157	1-163-145-00	CERAMIC CHIP 0.0015uF	5% 50V	R135	1-216-295-91	SHORT 0	
C159	1-163-019-00	CERAMIC CHIP 0.0068uF	10% 50V	R136	1-216-295-91	SHORT 0	
C161	1-126-205-11	ELECT CHIP 47uF	20% 6.3V	R137	1-216-295-91	SHORT 0	
C162	1-126-205-11	ELECT CHIP 47uF	20% 6.3V				
C163	1-126-205-11	ELECT CHIP 47uF	20% 6.3V				
C164	1-163-038-91	CERAMIC CHIP 0.1uF	25V				
C165	1-163-038-91	CERAMIC CHIP 0.1uF	25V				
C166	1-163-038-91	CERAMIC CHIP 0.1uF	25V				

BD	D. MOTOR	D. SENS (IN)	D. SENS (OUT)	D. SW	DISPLAY
-----------	-----------------	---------------------	----------------------	--------------	----------------

Ref. No.	Part No.	Description	Remark
R138	1-216-295-91	SHORT	0
R143	1-216-103-00	METAL CHIP	180K 5% 1/10W
R144	1-216-103-00	METAL CHIP	180K 5% 1/10W
R147	1-216-081-00	METAL CHIP	22K 5% 1/10W
R148	1-216-001-00	METAL CHIP	10 5% 1/10W
R149	1-216-003-11	RES,CHIP	12 5% 1/10W
R158	1-216-111-00	METAL CHIP	390K 5% 1/10W
R159	1-216-101-00	METAL CHIP	150K 5% 1/10W
R161	1-216-308-00	METAL CHIP	4.7 5% 1/10W
R162	1-216-101-00	METAL CHIP	150K 5% 1/10W
R171	1-216-077-00	METAL CHIP	15K 5% 1/10W
R172	1-216-077-00	METAL CHIP	15K 5% 1/10W
R173	1-216-077-00	METAL CHIP	15K 5% 1/10W
R181	1-216-077-00	METAL CHIP	15K 5% 1/10W
R182	1-216-077-00	METAL CHIP	15K 5% 1/10W
R183	1-216-077-00	METAL CHIP	15K 5% 1/10W
R618	1-216-049-91	RES,CHIP	1K 5% 1/10W
		< SWITCH >	
S101	1-572-085-11	SWITCH, LEAF (LIMIT IN SW)	
		< VIBRATOR >	
X101	1-767-408-21	VIBRATOR, CRYSTAL (16.9344MHz)	

	1-672-637-11	D.MOTOR BOARD	*****
		< MOTOR >	
M83	1-541-632-11	MOTOR, DC (DOOR)	

	1-672-640-11	D.SENS (IN) BOARD	*****
*	4-985-300-01	HOLDER (P-T)	
		< TRANSISTOR >	
Q81	8-729-926-31	PHOTO TRANSISTOR PT483F1S (DISC SENSOR)	

	1-672-641-11	D.SENS (OUT) BOARD	*****
		< DIODE >	
D81	8-719-055-84	DIODE GL-528VS1 (DISC SENSOR)	

	1-672-634-11	D.SW BOARD	*****
		< RESISTOR >	
R82	1-249-415-11	CARBON	680 5% 1/4W F
R83	1-249-417-11	CARBON	1K 5% 1/4W F
R84	1-249-419-11	CARBON	1.5K 5% 1/4W F

Ref. No.	Part No.	Description	Remark
		< SWITCH >	
SW83	1-571-300-21	SWITCH, ROTARY	
SW84	1-571-300-21	SWITCH, ROTARY	

	A-4724-546-A	DISPLAY BOARD, COMPLETE (CX350)	*****
	A-4724-566-A	DISPLAY BOARD, COMPLETE (CX300/CX691)	*****
	4-982-811-11	HOLDER (FL)	
		< CAPACITOR >	
C701	1-162-294-31	CERAMIC	0.001uF 10% 50V
C702	1-162-215-31	CERAMIC	47PF 5% 50V
C703	1-162-306-11	CERAMIC	0.01uF 20% 16V
C704	1-164-159-11	CERAMIC	0.1uF 50V
C706	1-162-282-31	CERAMIC	100PF 10% 50V
C707	1-162-282-31	CERAMIC	100PF 10% 50V
C708	1-162-282-31	CERAMIC	100PF 10% 50V
C709	1-162-288-31	CERAMIC	330PF 10% 50V
C710	1-124-584-00	ELECT	100uF 20% 10V
C711	1-164-159-11	CERAMIC	0.1uF 50V
C771	1-162-306-11	CERAMIC	0.01uF 20% 16V (CX350)
C772	1-126-924-11	ELECT	330uF 20% 6.3V (CX350)
C773	1-162-306-11	CERAMIC	0.01uF 20% 16V (CX350)
C774	1-126-924-11	ELECT	330uF 20% 6.3V (CX350)
C775	1-162-306-11	CERAMIC	0.01uF 20% 16V (CX350)
C776	1-126-924-11	ELECT	330uF 20% 6.3V (CX350)
C781	1-164-159-11	CERAMIC	0.1uF 50V
C791	1-124-584-00	ELECT	100uF 20% 10V
		< CONNECTOR >	
CN701	1-568-838-11	SOCKET, CONNECTOR 21P	
* CN702	1-568-954-11	PIN, CONNECTOR 5P (CX350)	
		< DIODE >	
D701	8-719-046-39	DIODE SEL5821A-TH15	
D702	8-719-046-39	DIODE SEL5821A-TH15	
D703	8-719-046-39	DIODE SEL5821A-TH15	
D704	8-719-046-39	DIODE SEL5821A-TH15	
D705	8-719-046-39	DIODE SEL5821A-TH15	
D706	8-719-046-39	DIODE SEL5821A-TH15	
D707	8-719-046-39	DIODE SEL5821A-TH15	
D708	8-719-046-39	DIODE SEL5821A-TH15	
D709	8-719-046-39	DIODE SEL5821A-TH15	
D710	8-719-046-44	DIODE SEL5221S	
D771	8-719-059-14	DIODE SID313BP-TP19 (CX350)	
D772	8-719-059-14	DIODE SID313BP-TP19 (CX350)	
D773	8-719-059-14	DIODE SID313BP-TP19 (CX350)	
D774	8-719-059-14	DIODE SID313BP-TP19 (CX350)	
D775	8-719-059-14	DIODE SID313BP-TP19 (CX350)	

DISPLAY

JACK

Ref. No.	Part No.	Description	Remark
D780	8-719-911-19	DIODE 1SS119 (CX350)	
D781	8-719-911-19	DIODE 1SS119 (CX350)	
D782	8-719-911-19	DIODE 1SS119 (CX350)	
		< GROUND TERMINAL >	
EB701	1-690-880-41	LEAD (WITH CONNECTOR)	
		< FLUORESCENT INDICATOR >	
FL701	1-517-861-11	INDICATOR TUBE, FLUORESCENT	
		< IC >	
IC701	8-759-498-92	IC MSM9202-03GS-K	
IC702	8-759-183-47	IC M66310FP	
IC703	8-749-014-66	IC NJL56H400A	
		< TRANSISTOR >	
Q701	8-729-900-80	TRANSISTOR DTC114ES	
Q771	8-729-801-93	TRANSISTOR 2SD1387 (CX350)	
Q772	8-729-801-93	TRANSISTOR 2SD1387 (CX350)	
Q773	8-729-801-93	TRANSISTOR 2SD1387 (CX350)	
		< RESISTOR >	
R701	1-249-441-11	CARBON 100K	5% 1/4W
R702	1-247-807-31	CARBON 100	5% 1/4W
R703	1-247-807-31	CARBON 100	5% 1/4W
R704	1-247-807-31	CARBON 100	5% 1/4W
R705	1-247-807-31	CARBON 100	5% 1/4W
R706	1-247-843-11	CARBON 3.3K	5% 1/4W
R707	1-247-807-31	CARBON 100	5% 1/4W
R708	1-247-807-31	CARBON 100	5% 1/4W
R709	1-247-807-31	CARBON 100	5% 1/4W
R711	1-249-411-11	CARBON 330	5% 1/4W
R712	1-249-411-11	CARBON 330	5% 1/4W
R713	1-249-413-11	CARBON 470	5% 1/4W F
R714	1-249-413-11	CARBON 470	5% 1/4W F
R721	1-249-415-11	CARBON 680	5% 1/4W F
R722	1-249-417-11	CARBON 1K	5% 1/4W F
R723	1-249-419-11	CARBON 1.5K	5% 1/4W F
R724	1-249-421-11	CARBON 2.2K	5% 1/4W F
R725	1-247-843-11	CARBON 3.3K	5% 1/4W
R726	1-249-427-11	CARBON 6.8K	5% 1/4W F
R727	1-249-431-11	CARBON 15K	5% 1/4W
R731	1-249-415-11	CARBON 680	5% 1/4W F
R732	1-249-417-11	CARBON 1K	5% 1/4W F
R733	1-249-419-11	CARBON 1.5K	5% 1/4W F
R734	1-249-421-11	CARBON 2.2K	5% 1/4W F
R735	1-247-843-11	CARBON 3.3K	5% 1/4W
R736	1-249-427-11	CARBON 6.8K	5% 1/4W F
R742	1-249-415-11	CARBON 680	5% 1/4W F
R771	1-249-383-11	CARBON 1.5	5% 1/6W F (CX350)
R772	1-249-383-11	CARBON 1.5	5% 1/6W F (CX350)
R773	1-249-383-11	CARBON 1.5	5% 1/6W F (CX350)
R774	1-249-383-11	CARBON 1.5	5% 1/6W F (CX350)

Ref. No.	Part No.	Description	Remark
R775	1-247-772-00	CARBON 3.6	5% 1/4W (CX350)
R776	1-247-772-00	CARBON 3.6	5% 1/4W (CX350)
R791	1-249-429-11	CARBON 10K	5% 1/4W
R792	1-249-429-11	CARBON 10K	5% 1/4W
		< SWITCH >	
S721	1-572-184-11	SWITCH, KEYBOARD (GROUP FILE)	
S722	1-572-184-11	SWITCH, KEYBOARD (GROUP 8)	
S723	1-572-184-11	SWITCH, KEYBOARD (GROUP 7)	
S724	1-572-184-11	SWITCH, KEYBOARD (GROUP 6)	
S725	1-572-184-11	SWITCH, KEYBOARD (GROUP 5)	
S726	1-572-184-11	SWITCH, KEYBOARD (GROUP 1)	
S727	1-572-184-11	SWITCH, KEYBOARD (I/C) STANDBY)	
S728	1-570-157-51	SWITCH, SLIDE (PLAY/OFF TIMER-SW)	
S731	1-572-184-11	SWITCH, KEYBOARD (GROUP 2)	
S732	1-572-184-11	SWITCH, KEYBOARD (GROUP 3)	
S733	1-572-184-11	SWITCH, KEYBOARD (GROUP 4)	
S734	1-572-184-11	SWITCH, KEYBOARD (CONTINUE)	
S735	1-572-184-11	SWITCH, KEYBOARD (SHUFFLE)	
S736	1-572-184-11	SWITCH, KEYBOARD (PROGRAM)	
S737	1-572-184-11	SWITCH, KEYBOARD (REPEAT)	
S741	1-572-184-11	SWITCH, KEYBOARD (HITLIST)	
S742	1-572-184-11	SWITCH, KEYBOARD (TIME/TEXT)	

	1-672-629-11	JACK BOARD	*****
		< CAPACITOR >	
C327	1-124-282-00	ELECT 22uF	20% 25V
C328	1-162-290-31	CERAMIC 470PF	10% 50V
C427	1-124-282-00	ELECT 22uF	20% 25V
C428	1-162-290-31	CERAMIC 470PF	10% 50V
C951	1-164-159-11	CERAMIC 0.1uF	50V
C952	1-164-159-11	CERAMIC 0.1uF	50V
C953	1-104-665-11	ELECT 100uF	20% 10V
C954	1-164-159-11	CERAMIC 0.1uF	50V
		< IC >	
IC901	8-749-921-12	IC GP1F32T (DIGITAL OUT OPTICAL)	
		< JACK >	
* J901	1-764-188-11	JACK (SMALL TYPE) (DIA. 3.5)	(S-LINK CONTROL A1)
* J902	1-764-188-11	JACK (SMALL TYPE) (DIA. 3.5)	(S-LINK CONTROL A1)
J903	1-784-429-11	JACK, PIN 4P (2ND CD IN/LINE OUT)	
		< COIL >	
L950	1-410-503-11	INDUCTOR 3.3uH	
		< TRANSISTOR >	
Q950	8-729-620-05	TRANSISTOR 2SC2603-EF	

JACK	JOG	KEY
-------------	------------	------------

Ref. No.	Part No.	Ref. No.	Description	Part No.	Description	Remark
< RESISTOR >						
R339	1-215-485-00	METAL	470K	1%	1/4W	
R340	1-215-405-00	METAL	220	1%	1/4W	
R439	1-215-485-00	METAL	470K	1%	1/4W	
R440	1-215-405-00	METAL	220	1%	1/4W	
R950	1-249-425-11	CARBON	4.7K	5%	1/4W	F
R951	1-249-429-11	CARBON	10K	5%	1/4W	
R952	1-249-393-11	CARBON	10	5%	1/4W	F
< SWITCH >						
S902	1-762-910-11	SWITCH, SLIDE (COMMAND MODE CD)				

A-4724-545-A	JOG BOARD, COMPLETE (CX350)					

A-4724-565-A	JOG BOARD, COMPLETE (CX300/CX691)					

< DIODE >						
D711	8-719-046-40	DIODE	SEL5521C-TH8F (▷)			
D712	8-719-046-38	DIODE	SEL5821A-TH8F (■)			
D713	8-719-032-98	DIODE	SEL5820A (MEGA CONTROL)			
D714	8-719-032-86	DIODE	SEL5420E (EASY PLAY)			
D715	8-719-032-98	DIODE	SEL5820A (MEGA CONTROL)			
D716	8-719-032-86	DIODE	SEL5420E (EASY PLAY)			
< RESISTOR >						
R715	1-249-407-11	CARBON	150	5%	1/4W	F
R716	1-249-409-11	CARBON	220	5%	1/4W	F
R717	1-249-401-11	CARBON	47	5%	1/4W	F
R718	1-249-401-11	CARBON	47	5%	1/4W	F
R737	1-249-431-11	CARBON	15K	5%	1/4W	
R743	1-249-417-11	CARBON	1K	5%	1/4W	F
R744	1-249-419-11	CARBON	1.5K	5%	1/4W	F
R745	1-249-421-11	CARBON	2.2K	5%	1/4W	F
R746	1-247-843-11	CARBON	3.3K	5%	1/4W	
R747	1-249-427-11	CARBON	6.8K	5%	1/4W	F
R748	1-249-431-11	CARBON	15K	5%	1/4W	
R752	1-249-415-11	CARBON	680	5%	1/4W	F
R753	1-249-417-11	CARBON	1K	5%	1/4W	F
R754	1-249-419-11	CARBON	1.5K	5%	1/4W	F
R755	1-249-421-11	CARBON	2.2K	5%	1/4W	F
R756	1-247-843-11	CARBON	3.3K	5%	1/4W	
R757	1-249-427-11	CARBON	6.8K	5%	1/4W	F
R762	1-249-415-11	CARBON	680	5%	1/4W	F
R763	1-249-417-11	CARBON	1K	5%	1/4W	F
R764	1-249-419-11	CARBON	1.5K	5%	1/4W	F
R765	1-249-421-11	CARBON	2.2K	5%	1/4W	F
R766	1-247-843-11	CARBON	3.3K	5%	1/4W	
R767	1-249-427-11	CARBON	6.8K	5%	1/4W	F
R793	1-249-429-11	CARBON	10K	5%	1/4W	
< ROTARY ENCODER >						
RE701	1-475-543-11	ENCODER, ROTARY (◀◀ AMS ▶▶▶ PUSH ENTER)				

Ref. No.	Part No.	Description	Part No.	Description	Remark
RE702	1-475-543-11	ENCODER, ROTARY (DISC/CHARACTER PUSH ENTER)			
< SWITCH >					
S743	1-572-184-11	SWITCH, KEYBOARD (YES)			
S744	1-572-184-11	SWITCH, KEYBOARD (+100)			
S745	1-572-184-11	SWITCH, KEYBOARD (MENU/NO)			
S751	1-572-184-11	SWITCH, KEYBOARD (CLEAR)			
S752	1-572-184-11	SWITCH, KEYBOARD (FADER)			
S753	1-572-184-11	SWITCH, KEYBOARD (CHECK)			
S754	1-572-184-11	SWITCH, KEYBOARD (NO DELAY)			
S755	1-572-184-11	SWITCH, KEYBOARD (MEMO SEARCH)			
S756	1-572-184-11	SWITCH, KEYBOARD (X-FADE)			
S761	1-572-184-11	SWITCH, KEYBOARD (EASY PLAY)			
S762	1-572-184-11	SWITCH, KEYBOARD (MEGA CONTROL)			
S763	1-572-184-11	SWITCH, KEYBOARD (■/DISC EJECT)			
S764	1-572-184-11	SWITCH, KEYBOARD (■)			
S765	1-572-184-11	SWITCH, KEYBOARD (▷)			
S766	1-572-184-11	SWITCH, KEYBOARD (≡ OPEN/CLOSE)			

1-672-632-11	KEY BOARD BOARD				

< CAPACITOR >					
C792	1-126-925-11	ELECT	470uF	20%	10V
C821	1-164-159-11	CERAMIC	0.1uF		50V
C822	1-164-159-11	CERAMIC	0.1uF		50V
< CONNECTOR >					
* CNP203	1-568-944-11	PIN, CONNECTOR 6P (CX300/CX691)			
* CNP203	1-568-947-11	PIN, CONNECTOR 9P (CX350)			
< DIODE >					
D821	8-719-109-85	DIODE	RD5.1ES-B2		
D822	8-719-109-85	DIODE	RD5.1ES-B2		
D823	8-719-109-85	DIODE	RD5.1ES-B2		
< JACK >					
J821	1-785-945-11	CONNECTOR, DIN (KEY BOARD)			
< COIL >					
L821	1-424-122-11	FILTER, NOISE			
L822	1-424-122-11	FILTER, NOISE			
L823	1-424-122-11	FILTER, NOISE			
L824	1-424-122-11	FILTER, NOISE			
< RESISTOR >					
R801	1-249-429-11	CARBON	10K	5%	1/4W (CX300/CX691)

Ref. No.	Part No.	Description	Remark	Ref. No.	Part No.	Description	Remark
	1-672-636-11	L.T. MOTOR BOARD *****		C510	1-161-494-00	CERAMIC 0.022uF	25V
		< MOTOR >		C511	1-161-494-00	CERAMIC 0.022uF	25V
M81	1-541-632-11	MOTOR, DC (TABLE)		C512	1-161-494-00	CERAMIC 0.022uF	25V
M82	1-541-632-11	MOTOR, DC (LOADING)		C514	1-164-159-11	CERAMIC 0.1uF	50V
		*****		C516	1-164-159-11	CERAMIC 0.1uF	50V
	1-672-633-11	LED BOARD *****		C518	1-164-159-11	CERAMIC 0.1uF	50V
*	4-976-473-01	HOLDER (LED-S) < CAPACITOR >		C520	1-110-489-11	CAPACITOR 1F	5.5V
C804	1-164-159-11	CERAMIC 0.1uF	50V	C521	1-164-159-11	CERAMIC 0.1uF	50V
		< CONNECTOR >		C530	1-136-165-00	FILM 0.1uF	5% 50V
* CN813	1-568-942-11	PIN, CONNECTOR 4P < DIODE >		C531	1-126-933-11	ELECT 100uF	20% 16V
D802	8-719-071-41	DIODE SELS5923C-TP15		C532	1-164-159-11	CERAMIC 0.1uF	50V
D803	8-719-071-42	DIODE SEL5723C-TP15		C534	1-164-159-11	CERAMIC 0.1uF	50V
D804	8-719-072-76	DIODE SEL5E23C-TP15		C540	1-136-165-00	FILM 0.1uF	5% 50V
D805	8-719-071-42	DIODE SEL5723C-TP15		C541	1-126-933-11	ELECT 100uF	20% 16V
D806	8-719-071-41	DIODE SELS5923C-TP15 < RESISTOR >		C542	1-164-159-11	CERAMIC 0.1uF	50V
R805	1-249-401-11	CARBON 47 5% 1/4W F		C544	1-164-159-11	CERAMIC 0.1uF	50V
R806	1-249-399-11	CARBON 33 5% 1/4W F		C550	1-136-173-00	FILM 0.47uF	5% 50V
R807	1-249-401-11	CARBON 47 5% 1/4W F		C551	1-136-173-00	FILM 0.47uF	5% 50V
		*****		C552	1-109-953-11	ELECT 2.2uF	20% 50V
A-4724-557-A		MAIN BOARD, COMPLETE (CX350:US,CND) *****		C553	1-164-159-11	CERAMIC 0.1uF	50V
A-4724-560-A		MAIN BOARD, COMPLETE (CX350:AEP,UK,AUS) *****		C554	1-164-159-11	CERAMIC 0.1uF	50V
A-4724-567-A		MAIN BOARD, COMPLETE (CX300/CX691) *****		C555	1-164-159-11	CERAMIC 0.1uF	50V
7-685-871-01		SCREW +BVTT 3X6 (S) < CAPACITOR >		C559	1-126-967-11	ELECT 47uF	20% 50V
C301	1-126-965-11	ELECT 22uF 20% 50V		C560	1-136-173-00	FILM 0.47uF	5% 50V
C304	1-126-965-11	ELECT 22uF 20% 50V		C580	1-126-960-11	ELECT 1uF	20% 50V (CX350)
C305	1-104-664-11	ELECT 47uF 20% 10V		C581	1-164-159-11	CERAMIC 0.1uF	50V (CX350)
C307	1-126-964-11	ELECT 10uF 20% 50V		C582	1-104-665-11	ELECT 100uF	20% 10V (CX350)
C321	1-126-963-11	ELECT 4.7uF 20% 50V		C591	1-104-665-11	ELECT 100uF	20% 10V
C329	1-126-962-11	ELECT 3.3uF 20% 50V		C592	1-104-665-11	ELECT 100uF	20% 10V
C401	1-126-965-11	ELECT 22uF 20% 50V		C720	1-161-494-00	CERAMIC 0.022uF	25V
C404	1-126-965-11	ELECT 22uF 20% 50V		C730	1-161-494-00	CERAMIC 0.022uF	25V
C405	1-104-664-11	ELECT 47uF 20% 10V		C740	1-161-494-00	CERAMIC 0.022uF	25V
C407	1-126-964-11	ELECT 10uF 20% 50V		C750	1-161-494-00	CERAMIC 0.022uF	25V
C501	1-104-665-11	ELECT 100uF 20% 10V		C760	1-161-494-00	CERAMIC 0.022uF	25V
C502	1-164-159-11	CERAMIC 0.1uF 50V		C913	1-126-768-11	ELECT 2200uF	20% 16V
C503	1-161-494-00	CERAMIC 0.022uF 25V		C914	1-126-768-11	ELECT 2200uF	20% 16V
C504	1-104-665-11	ELECT 100uF 20% 10V		C915	1-126-933-11	ELECT 100uF	20% 16V
C505	1-161-494-00	CERAMIC 0.022uF 30% 28V		C917	1-126-925-11	ELECT 470uF	20% 10V
				C923	1-126-768-11	ELECT 2200uF	20% 16V
				C924	1-126-768-11	ELECT 2200uF	20% 16V
				C925	1-126-933-11	ELECT 100uF	20% 16V
				C926	1-126-933-11	ELECT 100uF	20% 16V
				C927	1-126-925-11	ELECT 470uF	20% 10V
				C928	1-126-925-11	ELECT 470uF	20% 10V
				C933	1-126-933-11	ELECT 100uF	20% 16V
				C936	1-126-963-11	ELECT 4.7uF	20% 50V
				C938	1-126-935-11	ELECT 470uF	20% 16V
				C939	1-126-963-11	ELECT 4.7uF	20% 50V
				C940	1-128-576-11	ELECT 100uF	20% 63V
				C941	1-126-948-11	ELECT 100uF	20% 35V
						< CONNECTOR >	
				* CN501	1-568-839-11	SOCKET, CONNECTOR 23P	
				CN502	1-568-838-11	SOCKET, CONNECTOR 21P	
				* CN503	1-568-936-11	PIN, CONNECTOR 9P (CX350)	
				* CN505	1-568-955-11	PIN, CONNECTOR 6P (CX300/CX691)	

MAIN

Ref. No.	Part No.	Description	Remark	Ref. No.	Part No.	Description	Remark
CN504	1-506-469-11	PIN, CONNECTOR 4P		Q521	8-729-030-08	TRANSISTOR DTC144VSA-TP	
CN505	1-506-469-11	PIN, CONNECTOR 4P		Q550	8-729-900-89	TRANSISTOR DTC144ES	
* CN506	1-564-518-11	PLUG, CONNECTOR 3P		Q551	8-729-900-65	TRANSISTOR DTA144ES	
* CN507	1-568-934-11	PIN, CONNECTOR 7P		Q552	8-729-900-65	TRANSISTOR DTA144ES	
* CN508	1-568-953-41	PIN, CONNECTOR 4P		Q559	8-729-620-05	TRANSISTOR 2SC2603-EF	
CN509	1-506-469-11	PIN, CONNECTOR 4P		Q560	8-729-900-89	TRANSISTOR DTC144ES	
* CN510	1-564-509-11	PLUG, CONNECTOR 6P		Q561	8-729-900-65	TRANSISTOR DTA144ES	
* CN511	1-568-935-11	PIN, CONNECTOR 8P		Q562	8-729-900-65	TRANSISTOR DTA144ES	
* CN901	1-564-511-11	PLUG, CONNECTOR 8P		Q570	8-729-900-80	TRANSISTOR DTC114ES	
* CN902	1-564-508-11	PLUG, CONNECTOR 5P		Q571	8-729-900-80	TRANSISTOR DTC114ES	
* CN903	1-564-507-11	PLUG, CONNECTOR 4P		Q572	8-729-422-57	TRANSISTOR UN4111	
		< DIODE >		Q573	8-729-422-57	TRANSISTOR UN4111	
D325	8-719-911-19	DIODE 1SS119		Q574	8-729-422-57	TRANSISTOR UN4111	
D327	8-719-911-19	DIODE 1SS119		Q576	8-729-422-57	TRANSISTOR UN4111 (CX300/CX691)	
D329	8-719-911-19	DIODE 1SS119		Q580	8-729-900-80	TRANSISTOR DTC114ES (CX350)	
D425	8-719-911-19	DIODE 1SS119		Q581	8-729-620-05	TRANSISTOR 2SC2603-EF (CX350)	
D501	8-719-911-19	DIODE 1SS119		Q940	8-729-140-97	TRANSISTOR 2SB734-34	
D521	8-719-911-19	DIODE 1SS119				< RESISTOR >	
D550	8-719-110-36	DIODE RD13ES-B2		R1	1-249-429-11	CARBON 10K 5% 1/4W	(CX300/CX691)
D580	8-719-911-19	DIODE 1SS119 (CX350)		R301	1-215-453-00	METAL 22K 1% 1/4W	
D940	8-719-024-99	DIODE 11ES2-NTA2B		R302	1-215-425-00	METAL 1.5K 1% 1/4W	
D941	8-719-110-72	DIODE RD30ESB2		R303	1-215-425-00	METAL 1.5K 1% 1/4W	
D942	8-719-109-93	DIODE RD6.2ESB2		R304	1-215-445-00	METAL 10K 1% 1/4W	
		< IC >		R305	1-215-443-00	METAL 8.2K 1% 1/4W	
IC302	8-749-015-59	IC BA4558-HT		R306	1-215-485-00	METAL 470K 1% 1/4W	
IC401	8-749-015-59	IC BA4558-HT		R307	1-215-427-00	METAL 1.8K 1% 1/4W	
IC402	8-749-015-59	IC BA4558-HT		R308	1-215-443-00	METAL 8.2K 1% 1/4W	
IC501	8-759-574-44	IC MN101C12G-SA		R309	1-215-417-00	METAL 680 1% 1/4W	
IC502	8-759-545-07	IC TMP87C447U-4A06 (CX350)		R310	1-215-445-00	METAL 10K 1% 1/4W	
IC503	8-759-267-86	IC SN74HC00ANS (CX350)		R311	1-215-445-00	METAL 10K 1% 1/4W	
IC504	8-759-463-99	IC M5M5256DFP-70XL		R312	1-215-445-00	METAL 10K 1% 1/4W	
IC505	8-759-822-38	IC LA6510		R313	1-215-477-00	METAL 220K 1% 1/4W	
IC506	8-759-822-38	IC LA6510		R314	1-215-405-00	METAL 220 1% 1/4W	
IC910	8-759-094-53	IC TA7805S		R315	1-215-405-00	METAL 220 1% 1/4W	
IC920	8-759-605-00	IC M5F78M07L		R316	1-215-373-31	METAL 10 1% 1/4W	
IC921	8-759-094-53	IC TA7805S		R317	1-215-443-00	METAL 8.2K 1% 1/4W	
IC930	8-759-173-39	IC NJU7201L50-T3		R321	1-249-421-11	CARBON 2.2K 5% 1/4W	F
IC931	8-759-821-93	IC LA5601		R322	1-249-421-11	CARBON 2.2K 5% 1/4W	F
		< TRANSISTOR >		R323	1-249-421-11	CARBON 2.2K 5% 1/4W	F
Q321	8-729-141-26	TRANSISTOR 2SC3622A-LK		R324	1-249-421-11	CARBON 2.2K 5% 1/4W	F
Q322	8-729-141-26	TRANSISTOR 2SC3622A-LK		R325	1-249-441-11	CARBON 100K 5% 1/4W	
Q323	8-729-141-26	TRANSISTOR 2SC3622A-LK		R326	1-249-441-11	CARBON 100K 5% 1/4W	
Q324	8-729-141-26	TRANSISTOR 2SC3622A-LK		R327	1-249-441-11	CARBON 100K 5% 1/4W	
Q325	8-729-900-65	TRANSISTOR DTA144ES		R328	1-249-441-11	CARBON 100K 5% 1/4W	
Q326	8-729-900-65	TRANSISTOR DTA144ES		R329	1-249-441-11	CARBON 100K 5% 1/4W	
Q327	8-729-900-65	TRANSISTOR DTA144ES		R401	1-215-453-00	METAL 22K 1% 1/4W	
Q328	8-729-900-65	TRANSISTOR DTA144ES		R402	1-215-425-00	METAL 1.5K 1% 1/4W	
Q329	8-729-900-65	TRANSISTOR DTA144ES		R403	1-215-425-00	METAL 1.5K 1% 1/4W	
Q421	8-729-141-26	TRANSISTOR 2SC3622A-LK		R404	1-215-445-00	METAL 10K 1% 1/4W	
Q422	8-729-141-26	TRANSISTOR 2SC3622A-LK		R405	1-215-443-00	METAL 8.2K 1% 1/4W	
Q423	8-729-141-26	TRANSISTOR 2SC3622A-LK		R406	1-215-485-00	METAL 470K 1% 1/4W	
Q424	8-729-141-26	TRANSISTOR 2SC3622A-LK		R407	1-215-427-00	METAL 1.8K 1% 1/4W	
Q425	8-729-900-65	TRANSISTOR DTA144ES		R408	1-215-443-00	METAL 8.2K 1% 1/4W	
Q426	8-729-900-65	TRANSISTOR DTA144ES		R409	1-215-417-00	METAL 680 1% 1/4W	
				R410	1-215-445-00	METAL 10K 1% 1/4W	

POWER	T. SENS	SW	SW2
--------------	----------------	-----------	------------

Ref. No.	Part No.	Description	Remark
C937	1-126-960-11	ELECT 1uF 20%	50V
		< CONNECTOR >	
* CN991	1-580-230-11	PIN, CONNECTOR (PC BOARD) 2P	
		< DIODE >	
D901	8-719-911-19	DIODE 1SS119	
D910	8-719-024-99	DIODE 11ES2-NTA2B	
D911	8-719-024-99	DIODE 11ES2-NTA2B	
D912	8-719-024-99	DIODE 11ES2-NTA2B	
D913	8-719-024-99	DIODE 11ES2-NTA2B	
D920	8-719-200-77	DIODE 10E2N	
D921	8-719-200-77	DIODE 10E2N	
D922	8-719-200-77	DIODE 10E2N	
D923	8-719-200-77	DIODE 10E2N	
D930	8-719-911-19	DIODE 1SS119	
D931	8-719-911-19	DIODE 1SS119	
D932	8-719-210-21	DIODE 11EQS04	
D933	8-719-210-21	DIODE 11EQS04	
D934	8-719-210-21	DIODE 11EQS04	
D935	8-719-210-21	DIODE 11EQS04	
D939	8-719-911-19	DIODE 1SS119	
		< GROUND TERMINAL >	
EB1	1-537-770-21	TERMINAL BOARD, GROUND	
EB2	1-537-770-21	TERMINAL BOARD, GROUND	
		< COIL >	
△L901	1-424-485-11	FILTER, LINE	
		< TRANSISTOR >	
Q930	8-729-620-05	TRANSISTOR 2SC2603-EF	
		< RESISTOR >	
R930	1-249-429-11	CARBON 10K 5%	1/4W
R931	1-249-421-11	CARBON 2.2K 5%	1/4W F
R933	1-249-429-11	CARBON 10K 5%	1/4W
R934	1-249-417-11	CARBON 1K 5%	1/4W F
		< RELAY >	
△RY901	1-755-299-11	RELAY	

	1-672-639-11	T. SENS BOARD	*****
		< CONNECTOR >	
CN81	1-506-486-11	PIN, CONNECTOR 7P	
CN82	1-506-481-11	PIN, CONNECTOR 2P	
CN83	1-506-481-11	PIN, CONNECTOR 2P	
		< IC >	
IC81	8-749-924-18	IC PHOTO INTERRUPTER RPI-1391	(TABLE SENSOR)
IC82	8-749-924-18	IC PHOTO INTERRUPTER RPI-1391	(TABLE SENSOR)

Ref. No.	Part No.	Description	Remark
IC83	8-749-924-18	IC PHOTO INTERRUPTER RPI-1391	(TABLE SENSOR)
IC84	8-749-924-18	IC PHOTO INTERRUPTER RPI-1391	(TABLE SENSOR)
		< RESISTOR >	
R81	1-249-416-11	CARBON 820 5%	1/4W F
R82	1-249-416-11	CARBON 820 5%	1/4W F
R83	1-249-416-11	CARBON 820 5%	1/4W F
R84	1-249-416-11	CARBON 820 5%	1/4W F
R85	1-249-415-11	CARBON 680 5%	1/4W F

	1-672-642-11	SW BOARD	*****
		< SWITCH >	
S81	1-571-300-21	SWITCH, ROTARY (LOADING DET)	

	1-672-643-11	SW2 BOARD	*****
		< SWITCH >	
S82	1-771-604-11	SWITCH, DETECTION (LOADING)	

		MISCELLANEOUS	

7	1-790-420-11	WIRE (FLAT TYPE) (21 CORE)	
8	1-773-183-11	WIRE (FLAT TYPE) (23 CORE)	
114	1-790-420-11	WIRE (FLAT TYPE) (21 CORE)	
273	1-769-069-11	WIRE (FLAT TYPE) (16 CORE)	
△301	8-848-379-31	OPTICAL PICK-UP KSS-213B/S-N	
△CNP901	1-575-651-21	CORD, POWER (CX350:AEP)	
△CNP901	1-696-845-11	CORD, POWER (CX350:AUS)	
△CNP901	1-751-529-11	CORD, POWER (CX350:UK)	
△CNP901	1-783-531-41	CORD, POWER (CX300/CX350:US,CND/CX691)	
FL701	1-517-861-11	INDICATOR TUBE, FLUORESCENT	
M101	X-2646-110-3	T.T CHASSIS ASSY (MB)(F)(SPINDLE)	
M102	X-2625-769-1	MOTOR GEAR ASSY (MB)(RP)(SLED)	
M81	A-4672-675-A	MOTOR ASSY (TABLE)	
M82	A-4672-675-A	MOTOR ASSY (LOADING)	
M83	X-4950-062-1	MOTOR ASSY (DOOR)	
△T901	1-433-666-11	TRANSFORMER, POWER	(CX300/CX350:US,CND/CX691)
△T901	1-433-668-11	TRANSFORMER, POWER (CX350:AEP,UK)	
△T901	1-433-877-11	TRANSFORMER, POWER (CX350:AUS)	
△T902	1-433-663-11	TRANSFORMER, POWER	(CX300/CX350:US,CND/CX691)
△T902	1-433-665-11	TRANSFORMER, POWER (CX350:AEP,UK,AUS)	

The components identified by mark △ or dotted line with mark △ are critical for safety. Replace only with part number specified.	Les composants identifiés par une marque △ sont critiques pour la sécurité. Ne les remplacer que par une pièce portant le numéro spécifié.
--	--

Ref. No.	Part No.	Description	Remark
ACCESSORIES & PACKING MATERIALS			

	1-418-254-11	REMOTE COMMANDER (RM-DX350) (CX350)	
	1-418-419-11	COMMANDER, REMOTE (RM-DX300) (CX300)	
	1-776-263-11	CORD, CONNECTION (AUDIO)	
	1-777-172-11	CORD, CONNECTION (CONTROL A1:CND)	
	3-810-765-11	MANUAL,COMMONNESS INSTRUCTION (FOR CONTROL A1) (CX300:US/CX350:US/CX691)	
	3-810-765-21	MANUAL,COMMONNESS INSTRUCTION (FOR CONTROL A1) (CX300:CND/CX350:CND,AEP,UK,AUS)	
	3-866-362-11	MANUAL, INSTRUCTION (ENGLISH) (CX300/CX691)	
	3-866-362-21	MANUAL, INSTRUCTION (FRENCH) (CX300:CND)	
	3-866-363-11	MANUAL, INSTRUCTION (ENGLISH) (CX350:US,AUS)	
	3-866-363-21	MANUAL, INSTRUCTION (ENGLISH, FRENCH) (CX350:CND,AEP,UK)	
	3-866-363-31	MANUAL, INSTRUCTION (SPANISH, PORTUGUESE, GERMAN) (CX350:AEP)	
	3-866-363-41	MANUAL, INSTRUCTION (DUTCH, SWEDISH, ITALIAN) (CX350:AEP)	
	4-219-390-01	LABEL (DISC NUMBER)	
	4-984-086-01	BOOKLET (100)	
	4-210-990-01	COVER, BATTERY (FOR RM-DX350) (CX350)	
	4-981-643-01	COVER, BATTERY (FOR RM-DX300) (CX300)	
	4-222-573-01	UPPER COVER (RM-DX350) (CX350)	

HARDWARE LIST

#1	7-685-646-79	SCREW +BVTP 3X8 TYPE2 N-S	
#2	7-685-871-01	SCREW +BVTT 3X6 (S)	
#3	7-685-650-79	SCREW +BVTP 3X16 TYPE2 N-S	
#4	7-685-903-11	SCREW +PTPWH 3X6 (TYPE2)	
#5	7-685-645-79	SCREW +BVTP 3X6 TYPE2 N-S	
#6	7-685-533-19	SCREW +BTP 2.6X6 TYPE2 N-S	
#7	7-624-106-04	STOP RING 3.0, TYPE -E	
#8	7-682-948-01	SCREW +PSW 3X8	
#9	7-621-775-00	SCREW +B 2.6X3	
#10	7-621-772-21	SCREW +B 2X5	

