

CDP-C425

SERVICE MANUAL

US Model
Canadian Model
AEP Model
UK Model
E Model

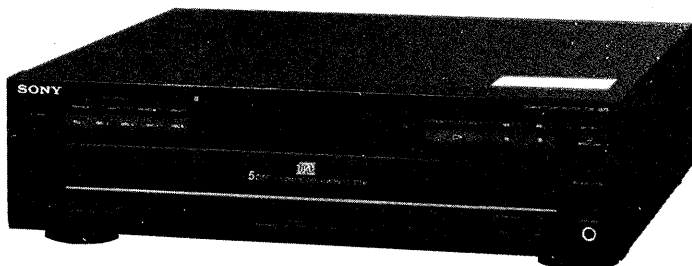

Model Name Using Similar Mechanism	CDP-C312M
Optical Pick-up Block Type	BU-5BD8B

SPECIFICATIONS

System	Compact disc digital audio system	Power consumption	12 W
Laser	Semiconductor laser ($\lambda=780$ nm) Emission duration: continuous	Dimensions	Approx. 430 × 125 × 385 mm (w/h/d) (17 × 5 × 15¼ inches) including projecting parts and controls
Laser output	Max. 44.6 μ W* * This output is the value measured at a distance of about 200 mm from the objective lens surface on the Optical Pick-up Block.	Weight	Approx. 5.6 kg (12 lbs 6 oz), net
Frequency response	2 Hz — 20 kHz (± 0.5 dB)	Remote commander RM-D325	
Signal to noise ratio	More than 100 dB	Remote control system	Infrared control
Dynamic range	More than 98 dB	Power requirements	3 V DC with two batteries size AA (IEC designation R6)
Harmonic distortion	Less than 0.005% (1 kHz)	Supplied accessories	
Channel separation	More than 100 dB (1 kHz)	Audio signal connecting cord	(phono plug × 2 ↔ phono plug × 2) (1)
Wow and flutter	Below measurable limit	Remote commander (1)	
Outputs	LINE OUT (phono jacks) Output level 2 V (at 50 kilohms) Load impedance over 10 kilohms PHONES (stereo phone jack) Output level 0 — 10 mW (variable) (at 32 ohms)	Sony SUM-3 (NS) batteries (2)	
		Operating Manual (1)	
General		Design and specifications subject to change without notice.	
Power requirements	US, Canadian Model: 120 V AC, 60Hz AEP Model: 220-230 V AC, 50/60Hz UK Model: 240 V AC, 50/60Hz E Model: 110-120, 220-240 V AC, 50/60Hz		

COMPACT DISC PLAYER
SONY®

Note on the Transit Key

The transit key on the bottom exterior of the unit protects the optical system against shock during transportation. Before operating the CD player, be sure to remove the key by following the instructions on the label, and store it in a safe place.

When transporting the unit, replace the key in its original hole and lock it in place.

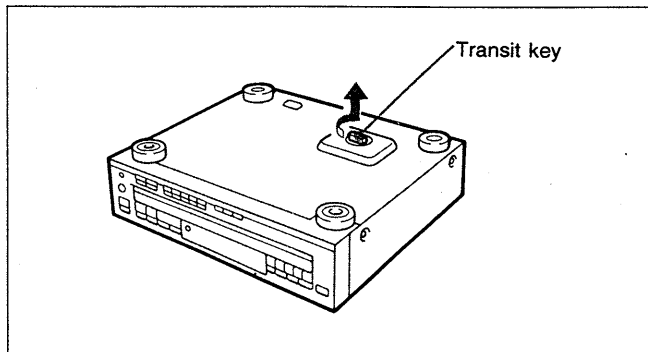

For the customers in Canada

CAUTION:
TO PREVENT ELECTRIC SHOCK, DO NOT USE THIS POLARIZED AC PLUG WITH AN EXTENSION CORD, RECEPTACLE OR OTHER OUTLET UNLESS THE BLADES CAN BE FULLY INSERTED TO PREVENT BLADE EXPOSURE.

THIS APPARATUS COMPLIES WITH THE CLASS B LIMITS FOR RADIO NOISE EMISSIONS SET OUT IN RADIO INTERFERENCE REGULATIONS.

TABLE OF CONTENTS

<u>Section</u>	<u>Title</u>	<u>Page</u>	<u>Section</u>	<u>Title</u>	<u>Page</u>
1. GENERAL			5. EXPLODED VIEWS		
1-1. Location of Controls		5	5-1. Front Panel and Case Assemblies		21
2. DISASSEMBLY			5-2. Disc Tray Assembly		22
2-1. Removal of Front Panel and Case Assemblies		6	5-3. Chassis Assembly		23
2-2. Removal of Disc Tray Assembly		6	5-4. Optical Pick-up Block Assembly (BU-5BD8B)		24
2-3. Removal of Optical Pick-up Block Assembly		6	6. ELECTRICAL PARTS LIST		25
3. ELECTRICAL BLOCK CHECKING		7			
4. DIAGRAMS					
4-1. Circuit Boards Location		9			
4-2. Semiconductor Lead Layouts		9			
4-3. IC Block Diagrams		10			
4-4. Printed Wiring Boards		12			
4-5. Schematic Diagram		17			

SAFETY-RELATED COMPONENT WARNING!!
COMPONENTS IDENTIFIED BY MARK OR DOTTED LINE WITH MARK ON THE SCHEMATIC DIAGRAMS AND IN THE PARTS LIST ARE CRITICAL TO SAFE OPERATION. REPLACE THESE COMPONENTS WITH SONY PARTS WHOSE PART NUMBERS APPEAR AS SHOWN IN THIS MANUAL OR IN SUPPLEMENTS PUBLISHED BY SONY.

ATTENTION AU COMPOSANT AYANT RAPPORT À LA SÉCURITÉ!
LES COMPOSANTS IDENTIFIÉS PAR UNE MARQUE SUR LES DIAGRAMMES SCHÉMATIQUES ET LA LISTE DES PIÈCES SONT CRITIQUES POUR LA SÉCURITÉ DE FONCTIONNEMENT. NE REMPLACER CES COMPOSANTS QUE PAR DES PIÈCES SONY DONT LES NUMÉROS SONT DONNÉS DANS CE MANUEL OU DANS LES SUPPLÉMENTS PUBLIÉS PAR SONY.

MODEL IDENTIFICATION

—Model Number Label—

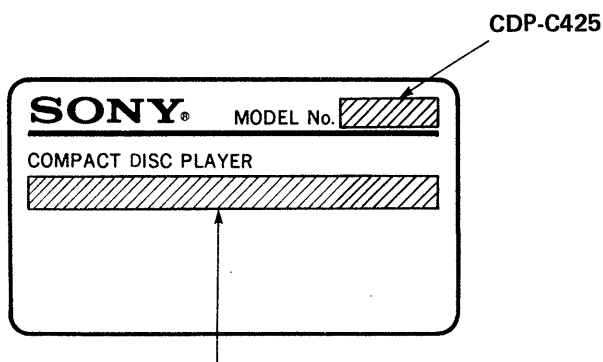

US, Canadian model : AC : 120V 60Hz

AEP model : AC : 220-230V~50/60Hz

UK model : AC : 240V~50/60Hz

E model : AC : 110-120V, 220-240V~50/60Hz

NOTES ON HANDLING THE OPTICAL PICK-UP BLOCK OR BASE UNIT

The laser diode in the optical pick-up block may suffer electrostatic breakdown because of the potential difference generated by the charged electrostatic load, etc. on clothing and the human body.

During repair, pay attention to electrostatic breakdown and also use the procedure in the printed matter which is included in the repair parts.

The flexible board is easily damaged and should be handled with care.

NOTES ON LASER DIODE EMISSION CHECK

The laser beam on this model is concentrated so as to be focused on the disc reflective surface by the objective lens in the optical pick-up block. Therefore, when checking the laser diode emission, observe from more than 30cm away from the objective lens.

SAFETY CHECK-OUT

After correcting the original service problem, perform the following safety checks before releasing the set to the customer:

Check the antenna terminals, metal trim, "metallized" knobs, screws, and all other exposed metal parts for AC leakage. Check leakage as described below.

LEAKAGE TEST

The AC leakage from any exposed metal part to earth ground and from all exposed metal parts to any exposed metal part having a return to chassis, must not exceed 0.5 mA (500 microamperes). Leakage current can be measured by any one of three methods.

1. A commercial leakage tester, such as the Simpson 229 or RCA WT-540A. Follow the manufacturers' instructions to use these instruments.
2. A battery-operated AC milliammeter. The Data Precision 245 digital multimeter is suitable for this job.
3. Measuring the voltage drop across a resistor by means of a VOM or battery-operated AC voltmeter. The "limit" indication is 0.75 V, so analog meters must have an accurate low-voltage scale. The Simpson 250 and Sanwa SH-63Trd are examples of a passive VOM that is suitable. Nearly all battery operated digital multimeters that have a 2V AC range are suitable. (See Fig. A)

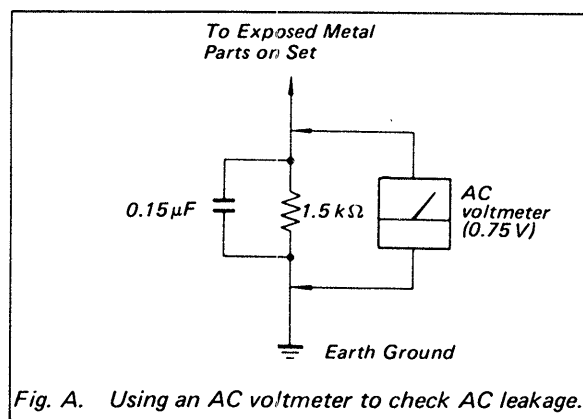

Fig. A. Using an AC voltmeter to check AC leakage.

PROTECTION OF EYES FROM LASER BEAM DURING SERVICING

This set employs a laser. Therefore, be sure to follow carefully the instructions below when servicing.

CAUTION

Use of controls or adjustments or performance of procedures other than those specified herein may result in hazardous radiation exposure.

1. Laser Diode Properties

- Material: GaAlAs
- Wavelength: 780 nm
- Emission Duration: continuous
- Laser Output: max. 44.6 μ W*

* This output is the value measured at a distance of about 200 mm from the objective lens surface on the Optical Pick-up Block.

2. During service, do not take the Optical Pick-up Block apart, and do not adjust the APC circuit. If there is a breakdown in the APC circuit (including laser diode), replace the entire Optical Pick-up Block (including APC board).

BESKYTTELSE AF ØJNE MOD LASERSTRÅLING UNDER SERVICE

I dette apparat anvendes laserlys. Derfor skal nedenstående instruktioner nøje følges under service.

Følg iverigt instruktionerne i servicemanualen.

ADVARSEL!!

Under service må øjnene ikke komme nær objektiv-linsen på den optiske pick-up enhed. I tilfælde af at det er nødvendigt at kontrollere udsendelsen af laserlys, skal det ske i en afstand af mere end 25 cm fra den optiske pick-up.

1. Laser-dioe data

- Materiale: GaAlAs
- Bølgelængde: 780 nm
- Udstråling: Kontinuerlig
- Laseroutput: Max. 0,4 mW*

* Målt i 1,6 mm afstand fra overfladen af objektiv-linsen på den optiske pick-up enhed.

- Klassifikation: Klasse IIIb.

2. Adskil aldrig den optiske pick-up enhed under service, og juster ikke APC kredsløbet (Automatic Power Control). Hvis APC kredsløbet (incl. laserdioden) bryder ned, skal hele den optiske pick-up enhed (incl. APC printkortet) udskiftes.

LASER ADVARSEL MÆRKNING

Følgende mærkning findes indvendig i apparatet:

1. Advarsel Mærkning

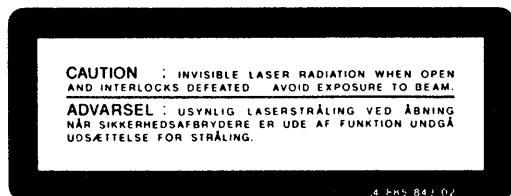

VAROITUS: Laite sisältää, laserdiodin, joka lähettää (näkyvätöntä) silmille vaarallista lasersäteilyä.

SECTION 1 GENERAL

1-1. LOCATION OF CONTROLS

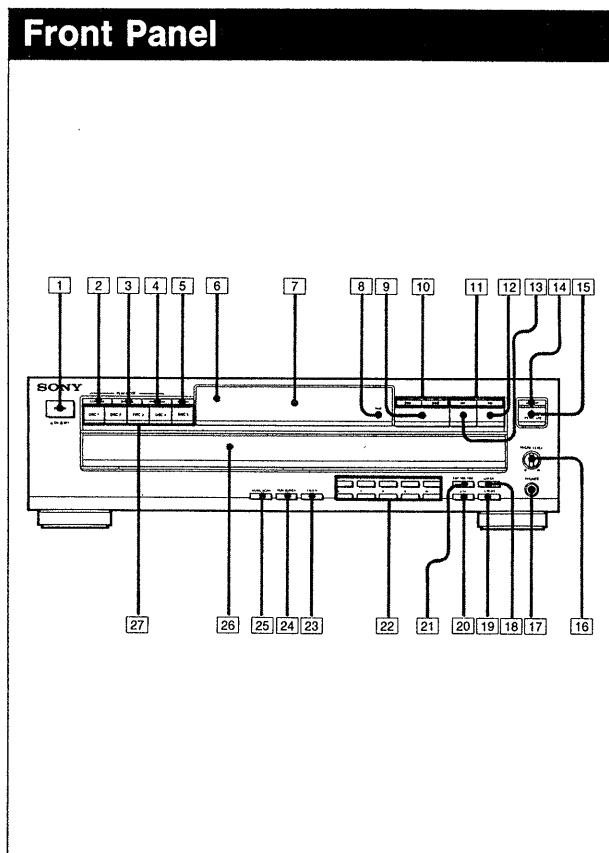

- 1 POWER switch
- 2 CONTINUE button
- 3 SHUFFLE button
- 4 PROGRAM button
- 5 REPEAT button
- 6 Remote sensor
- 7 Display window
- 8 TIME button
- 9 ▶ (play) button
- 10 ◀◀/▶▶ (AMS*) buttons
- 11 ◀◀/▶▶ (manual search) buttons
- 12 ■ (stop) button
- 13 || (pause) button
- 14 DISC SKIP button
- 15 ▲ OPEN/CLOSE button
- 16 PHONE LEVEL (Headphones) control
- 17 PHONES (Headphones) jack
- 18 CHECK (program check) button
- 19 CLEAR (program clear) button
- 20 > 10 (OVER 10) button
- 21 EDIT/TIME FADE button
- 22 Numeric buttons (1-10)
- 23 FADER button
- 24 PEAK SEARCH button
- 25 MUSIC SCAN button
- 26 Disc tray
- 27 DISC 1-5 buttons

* AMS is the abbreviation of Automatic Music Sensor.

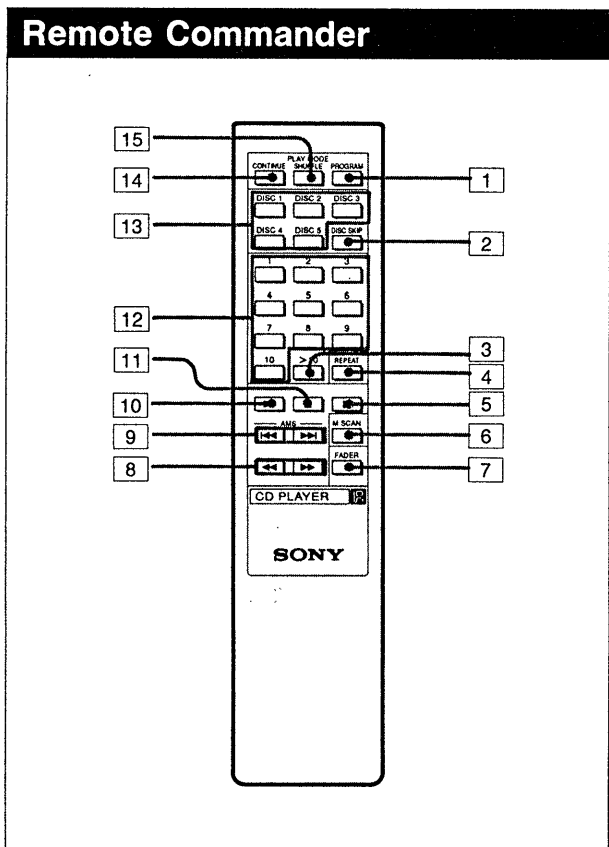

- 1 PROGRAM button
- 2 DISC SKIP button
- 3 > 10 (over 10) button
- 4 REPEAT button
- 5 ■ (stop) button
- 6 M.SCAN (Music scan) button
- 7 FADER button
- 8 ◀◀/▶▶ (manual search) buttons
- 9 ◀◀/▶▶ (AMS) buttons
- 10 ▶ (play) button
- 11 || (pause) button
- 12 Numeric buttons (1-10)
- 13 DISC 1-5 buttons
- 14 CONTINUE button
- 15 SHUFFLE button

SECTION 2 DISASSEMBLY

2-1. REMOVAL OF FRONT PANEL AND CASE ASSEMBLIES

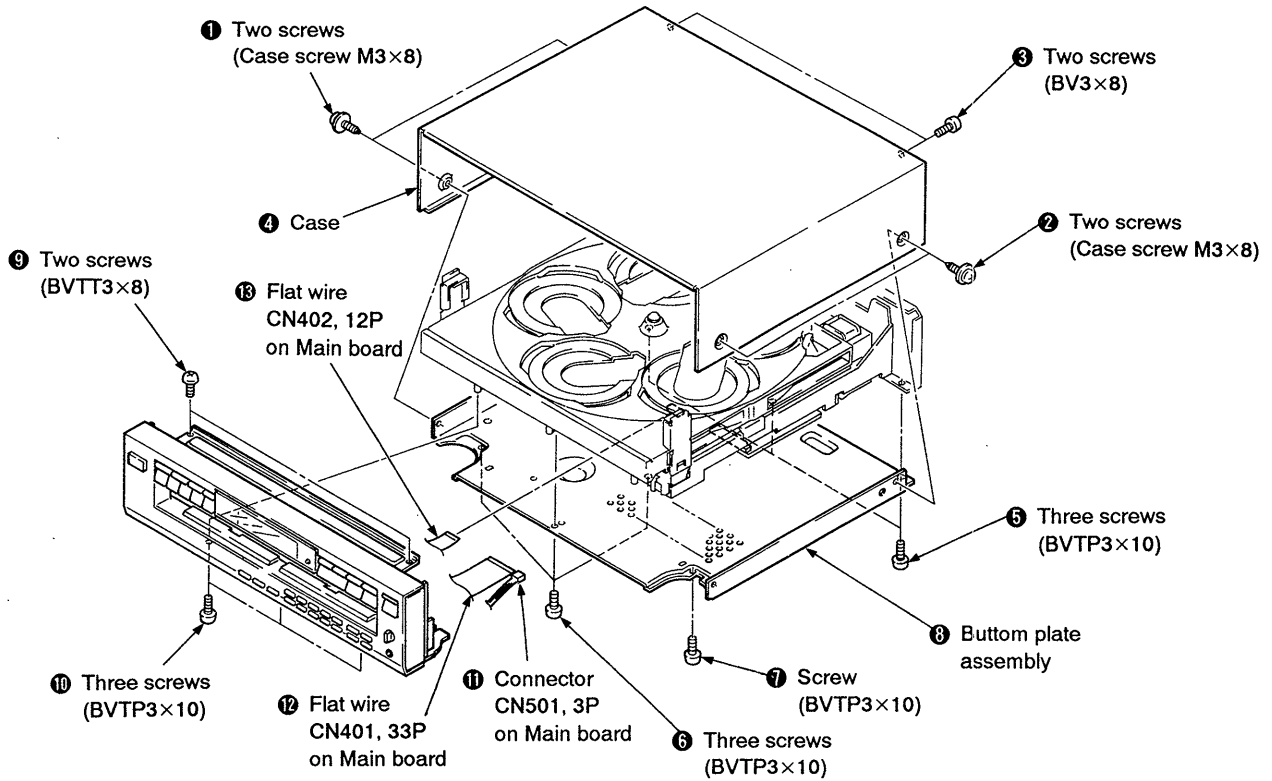

2-2. REMOVAL OF DISC TRAY ASSEMBLY

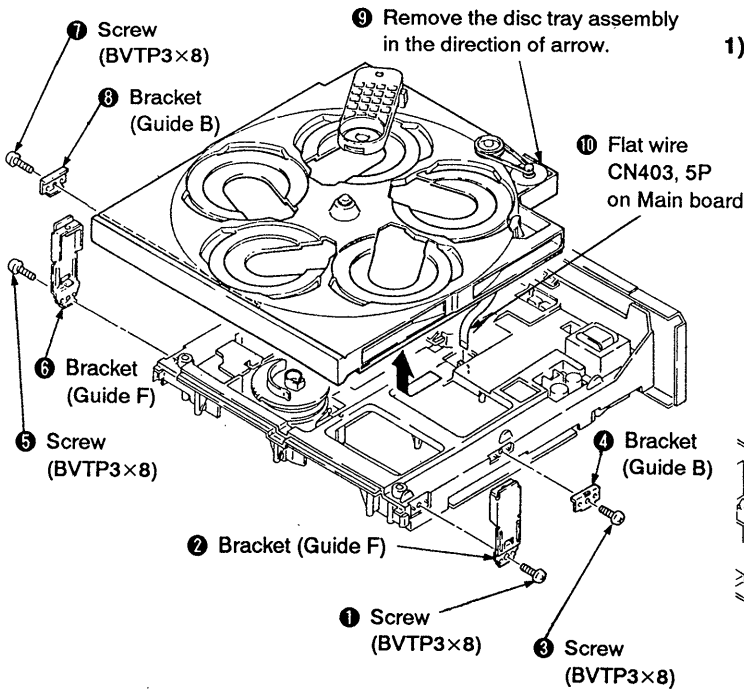

2-3. REMOVAL OF OPTICAL PICK-UP BLOCK ASSEMBLY

1) Replace the set up side down.

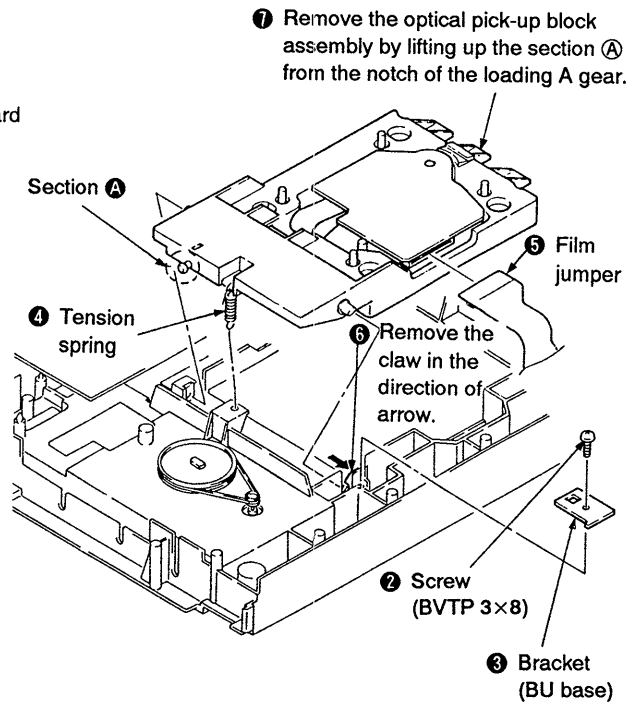

SECTION 3 ELECTRICAL BLOCK CHECKING

Note :

1. CD Block basically constructed to operate without adjustment. Therefore, check each item in order given.
2. Use YEDS-18 disc (3-702-101-01) unless otherwise indicated.
3. Use the oscilloscope with more than $10M\Omega$ impedance.
4. Clean an object lens by an applicator with neutral detergent when the signal level is low than specified value with the following checks.

S Curve Check

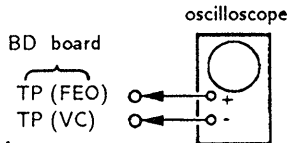

Procedure :

1. Connect oscilloscope to test point TP (FEO) on BD board.
2. Connect between test point TP (FES) and TP (VC) by lead wire.
3. Turned Power switch on and actuate the focus serch. (actuate the focus serch when disc table is moving in and out.)
4. Check the oscilloscope waveform (S curve) is symmetrical between A and B. And confirm peak to peak level within $3\pm 1V_{p-p}$.

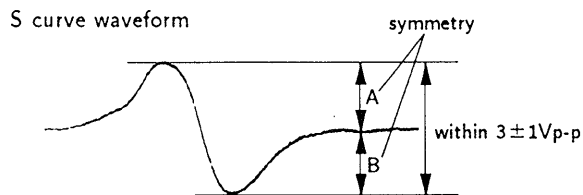

5. After check, remove the lead wire connected in step 2.

- Note :**
- Try to measure several times to make sure that the ratio of A : B or B : A is more than 10 : 7.
 - Take sweep time as long as possible and light up the brightness to obtain best waveform.

RF Level Check

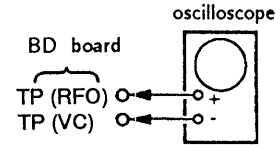

Procedure :

1. Connect oscilloscope to test point TP (RFO) on BD board.
2. Turn Power switch on.
3. Put disc (YEDS-18) in and playback.
4. Confirm that oscilloscope waveform is clear and check RF signal level is correct or not.

Note :

Clear RF signal waveform means that the shape “◇” can be clearly distinguished at the center of the waveform.

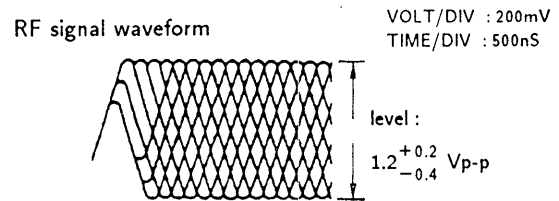

E-F Balance Check

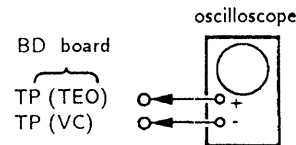

Procedure :

1. Connect test point TP (ADJ) to ground and TP (TES) to TP (VC) with lead wire.
2. Connect oscilloscope to test point TP (TEO) on BD board.
3. Turn Power switch on.
4. Put disc (YEDS-18) in and playback.
5. Confirm that the oscilloscope waveform is symmetrical on the top and bottom in relation to 0V, and check this level.

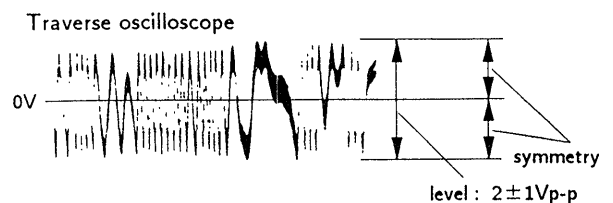

6. Remove the lead wire connected in step 1.

RF PLL Free-run Frequency Check

Procedure :

1. Connect frequency counter to test point (PCK) with lead wire.

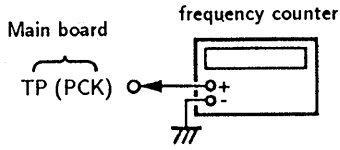

2. Turn Power switch on.
3. Confirm that reading on frequency counter is
4. 3218MHz.

Focus/Tracking Gain

This gain has a margin, so even if it is slightly off. There is no problem.

Therefore, do not perform, this adjustment.

Please note that it should be fixed to mechanical center position when you moved and do not know original position.

Adjustment Locations : [BD board]

— conductor side —

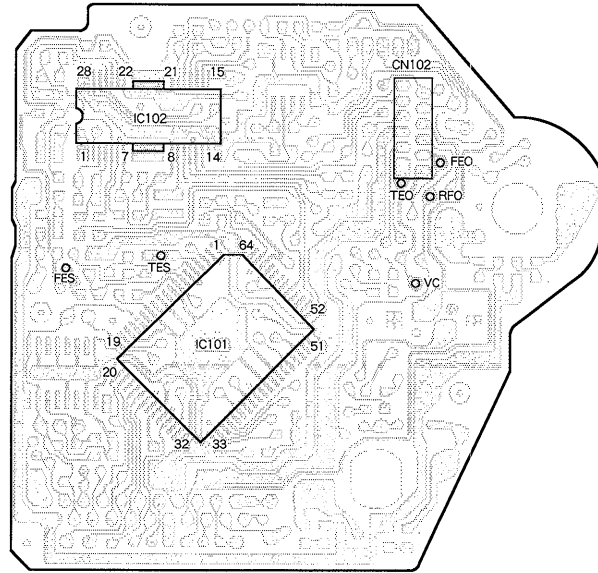

[Main board]

— component side —

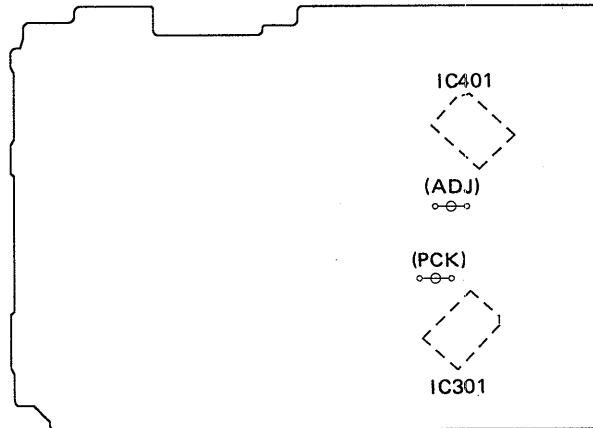

SECTION 4 DIAGRAMS

4-1. CIRCUIT BOARDS LOCATION

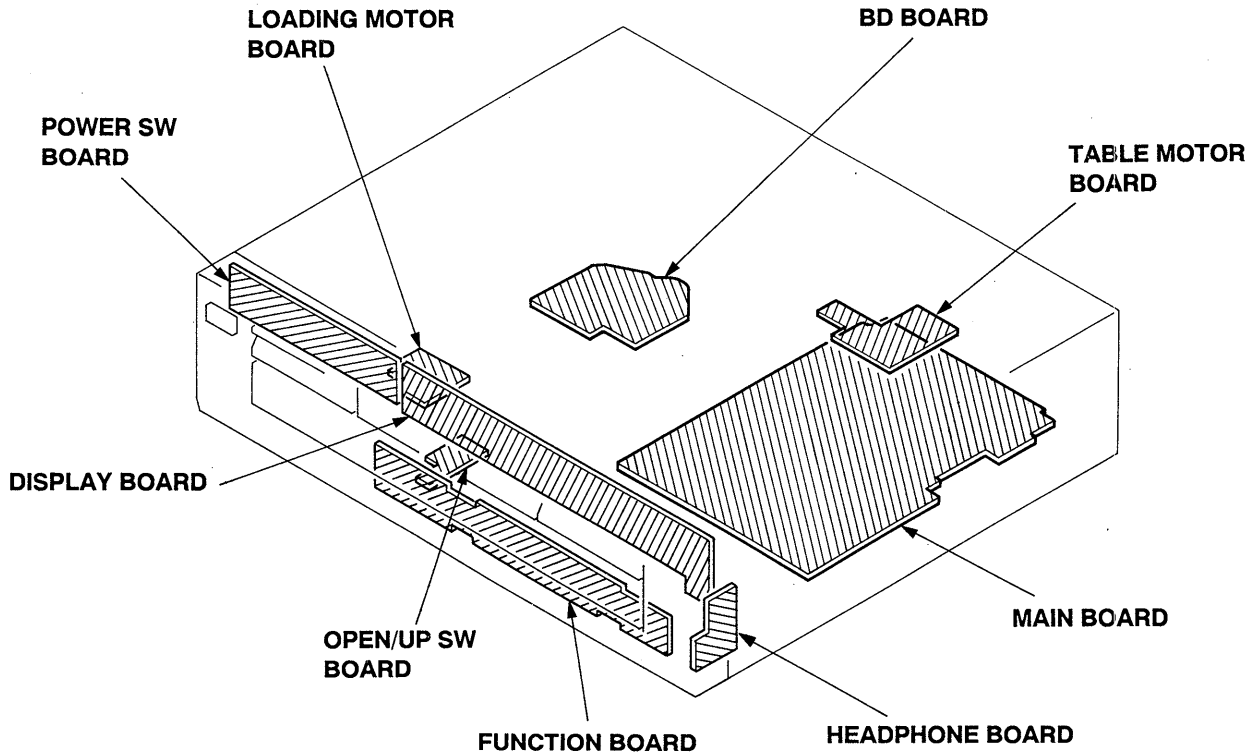

4-2. SEMICONDUCTOR LEAD LAYOUTS

BA6297FP

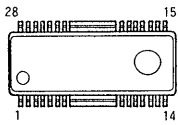

CXD25401Q

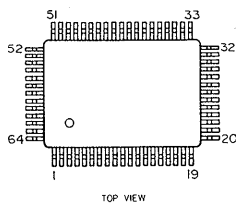

LA5602

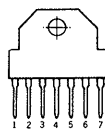

M5293L

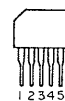

2SA1175-HFE

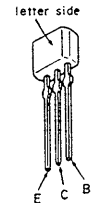

GP-1A521

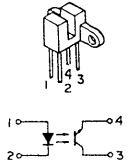

CXA1291P

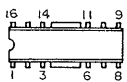

CXD2560M

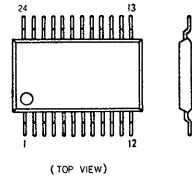

LA9215

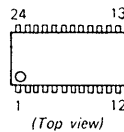

M5F7807L

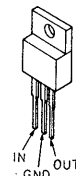

**DTA114ES
DTC114ES
DTC144ES**



**11ES2
1N4148M
RD8.2ES-B2**

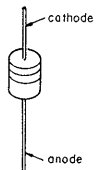

CXD2500AQ

CXP50116-267Q

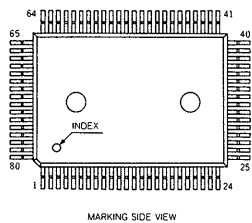

CXD2561BM

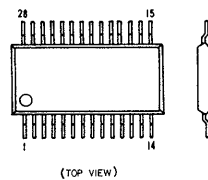

M5218AP

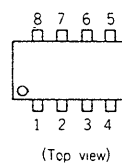

SBX1610-59

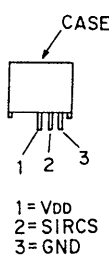

4-3. IC BLOCK DIAGRAMS

IC101 CXD2501Q

CXD2501

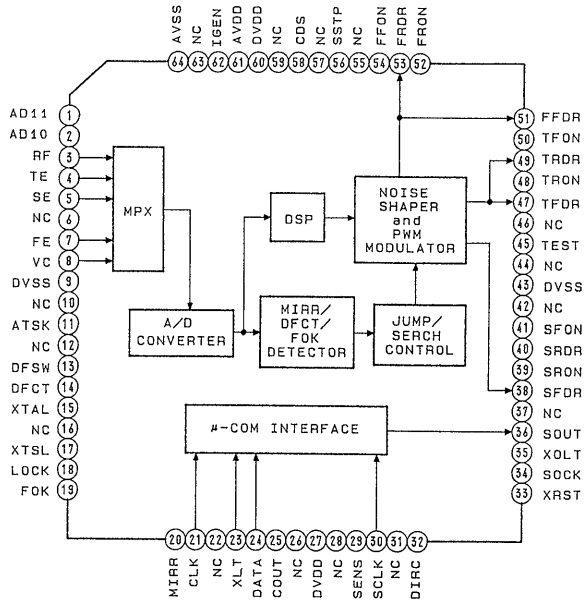

IC201 M5293L

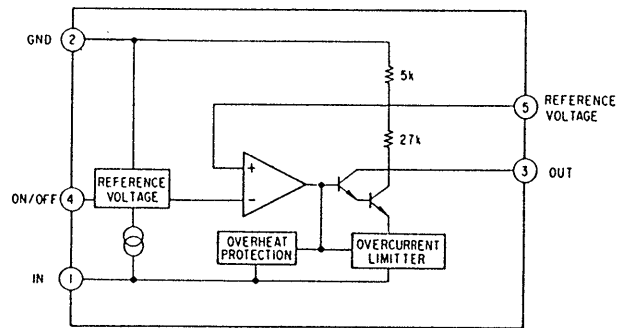

IC202 LA5602

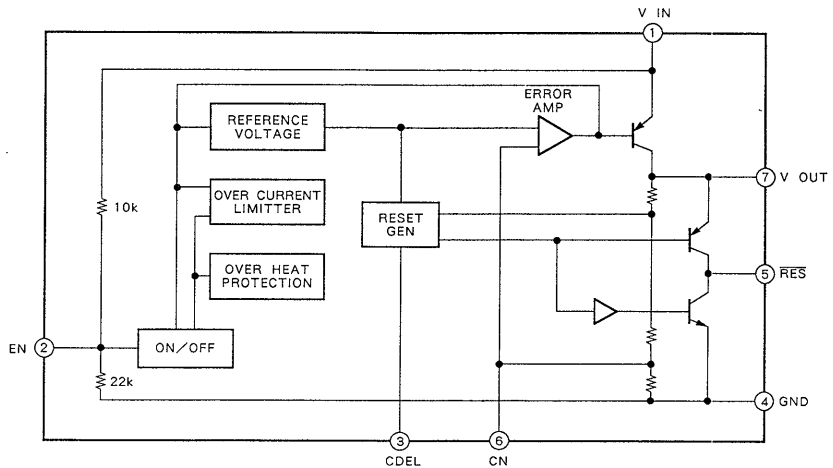

IC301 CXD2500AQ

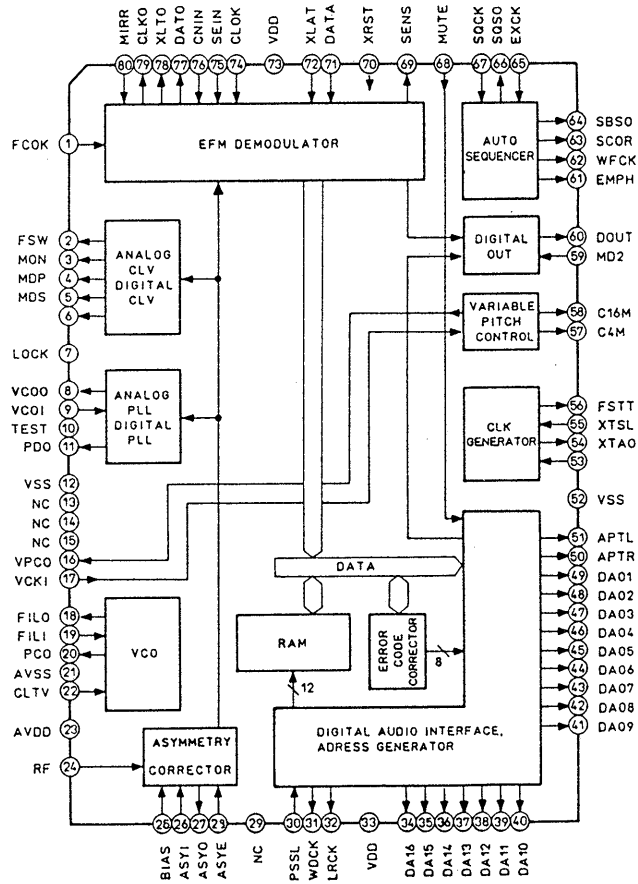

IC306 LA9215

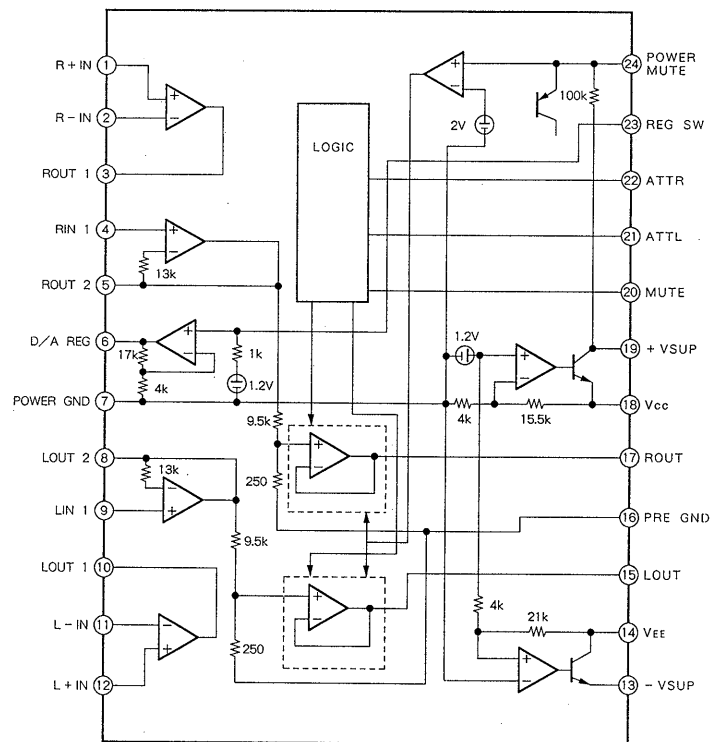

4-4. PRINTED WIRING BOARDS

• Refer to page 10 for IC BLOCK Diagrams.

• Semiconductor Location

Ref. No.	Location
D201	F-21
D202	F-21
D203	E-21
D204	E-21
D205	F-21
D206	E-21
D207	D-19
D208	H-19
D385	K-21
D701	I-28
IC101	E-27
IC102	G-26
IC201	F-21
IC202	F-20
IC204	E-21
IC301	H-16
IC302	J-18
IC303	I-20
IC306	I-23
IC401	F-16
IC402	E-17
IC501	G-20
IC701	F-7
Q201	G-20
Q302	H-21
Q303	H-21
Q304	H-21
Q305	H-21
Q401	D-15

Note:
 ○ : parts extracted from the component side.
 ● : Through hole.
 ▨ : Pattern on the side which is seen.
 ▩ : Pattern of the rear side.

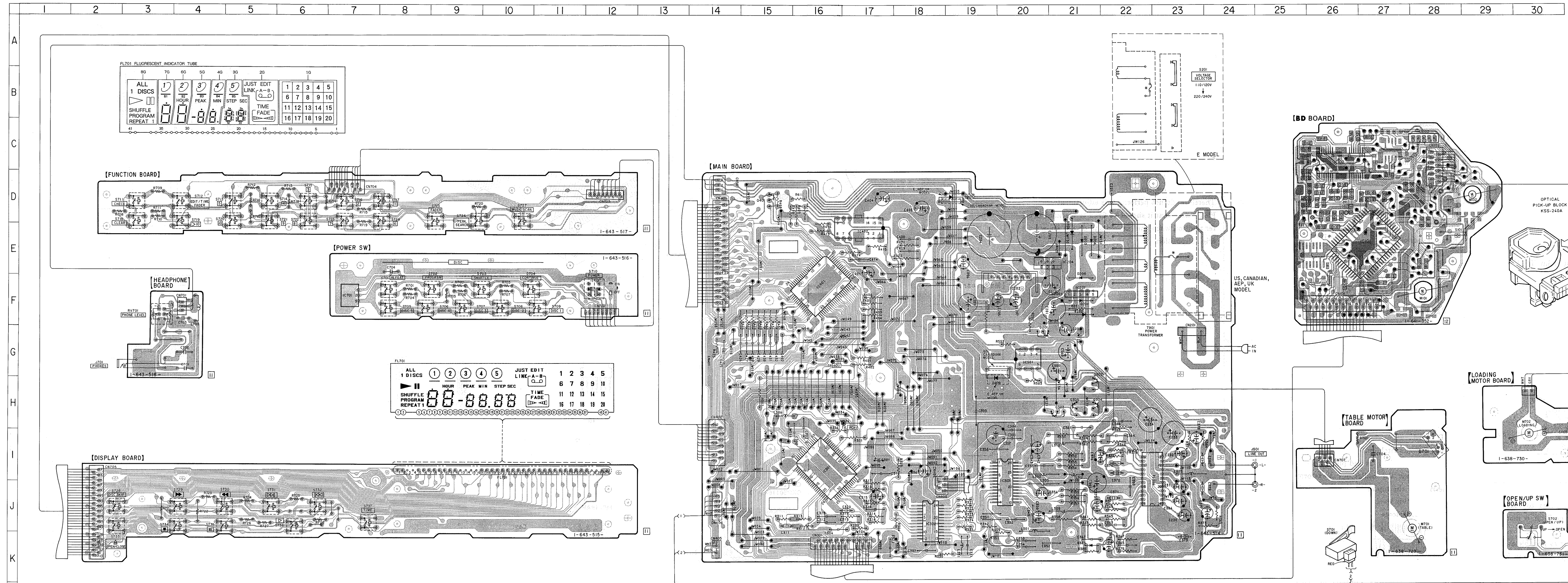

4-5. SCHEMATIC DIAGRAM

Refer to page 9 for Semiconductor Lead Layout.

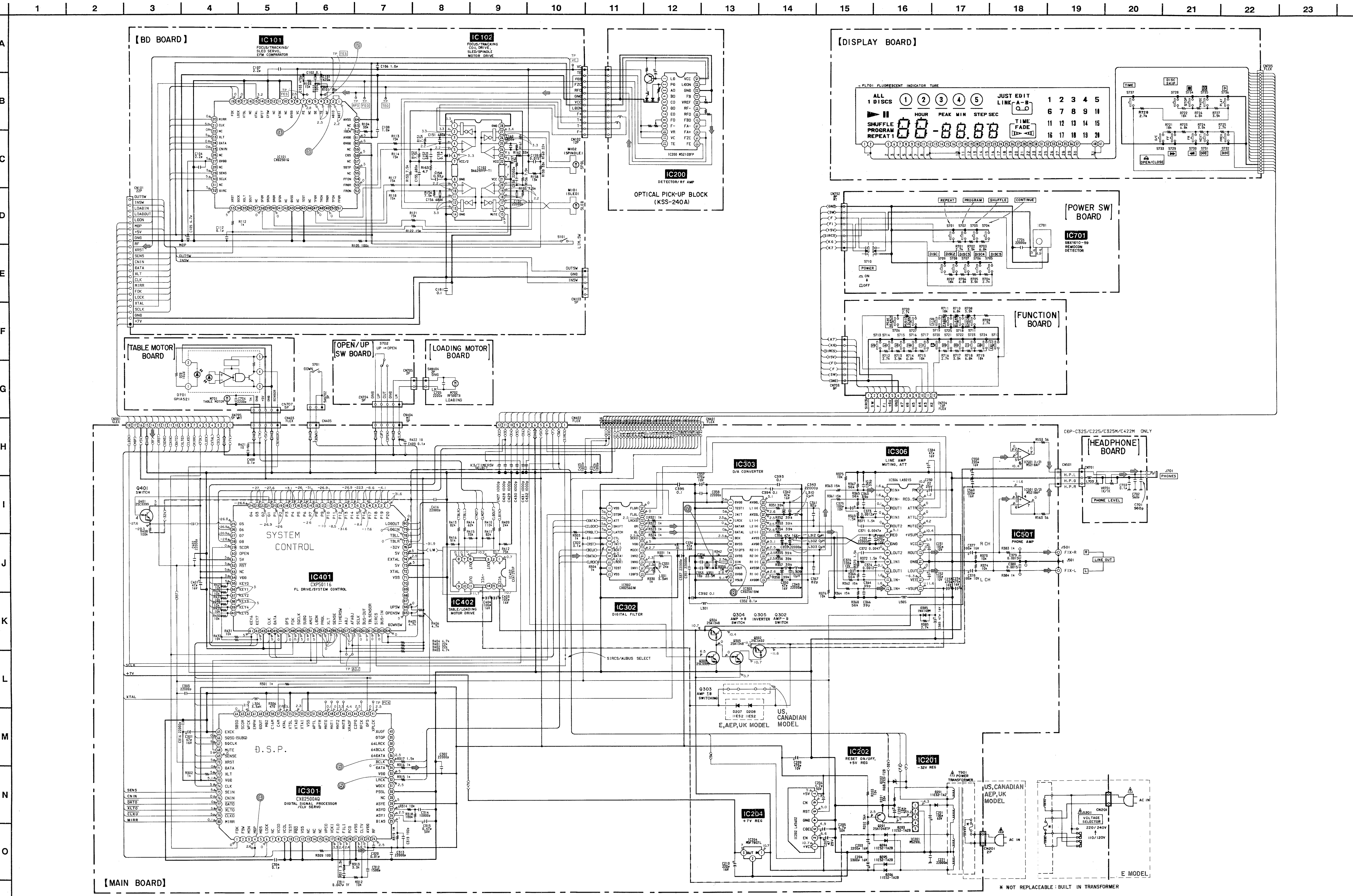

Note:

- All capacitors are in μF unless otherwise noted. pF : μF 50WV or less are not indicated except for electrolytics and tantalums.
- All resistors are in Ω and $\frac{1}{4}\text{W}$ or less unless otherwise specified.

Note: The components identified by mark **A** or dotted line with mark **A** are critical for safety. Replace only with part number specified.

Note: Les composants identifiés par une marque **A** sont critiques pour la sécurité. Ne les remplacer que par une pièce portant le numéro spécifié.

- : B+ Line
- : B- Line
- : adjustment for repair.
- Voltage and waveforms are dc with respect to ground under no-signal (detuned) conditions.
- Voltages are taken with a VOM (Input Impedance 10M Ω). Voltage variations may be noted due to normal production tolerances.
- Waveforms are taken with an oscilloscope. Voltage variations may be noted due to normal production tolerances.
- Circled numbers refer to waveforms.
- Signal path.

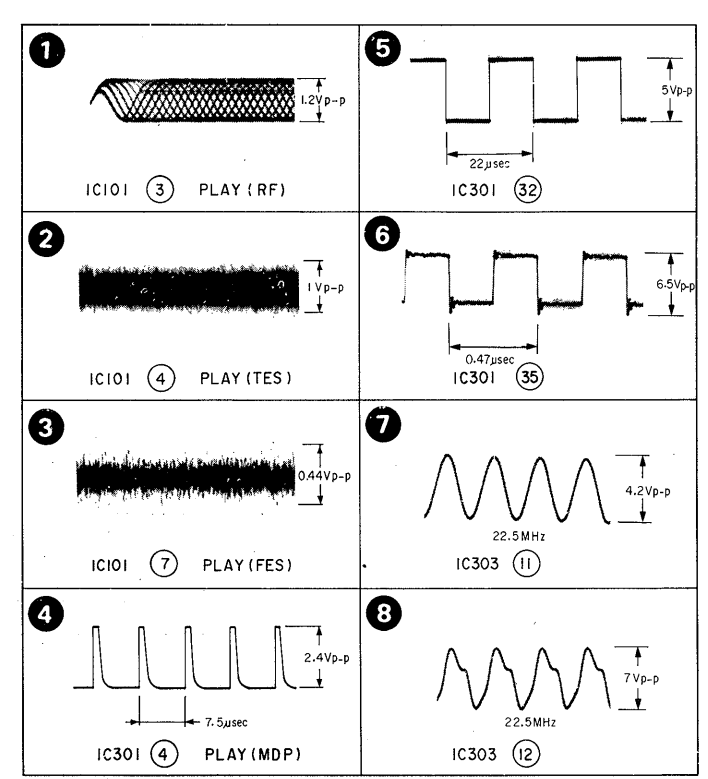

**SECTION 5
EXPLODED VIEWS**

NOTE:
 • -XX, -X mean standardized parts, so they may have some difference from the original one.
 • Color Indication of Appearance Parts
 Example:
 KNOB, BALANCE (WHITE) ... (RED)
 ↑
 Parts color Cabinet's color

• Items marked "*" are not stocked since they are seldom required for routine service. Some delay should be anticipated when ordering these items.
 • The mechanical parts with no reference number in the exploded views are not supplied.
 • Hardware (# mark) list is given in the last of this parts list.
 • Canadian model is abbreviated as CND.

The components identified by mark Δ or dotted line with mark Δ are critical for safety. Replace only with part number specified.
 Les composants identifiés par une marque Δ sont critiques pour la sécurité. Ne les remplacer que par une pièce portant le numéro spécifié.

5-1. FRONT PANEL AND CASE ASSEMBLIES

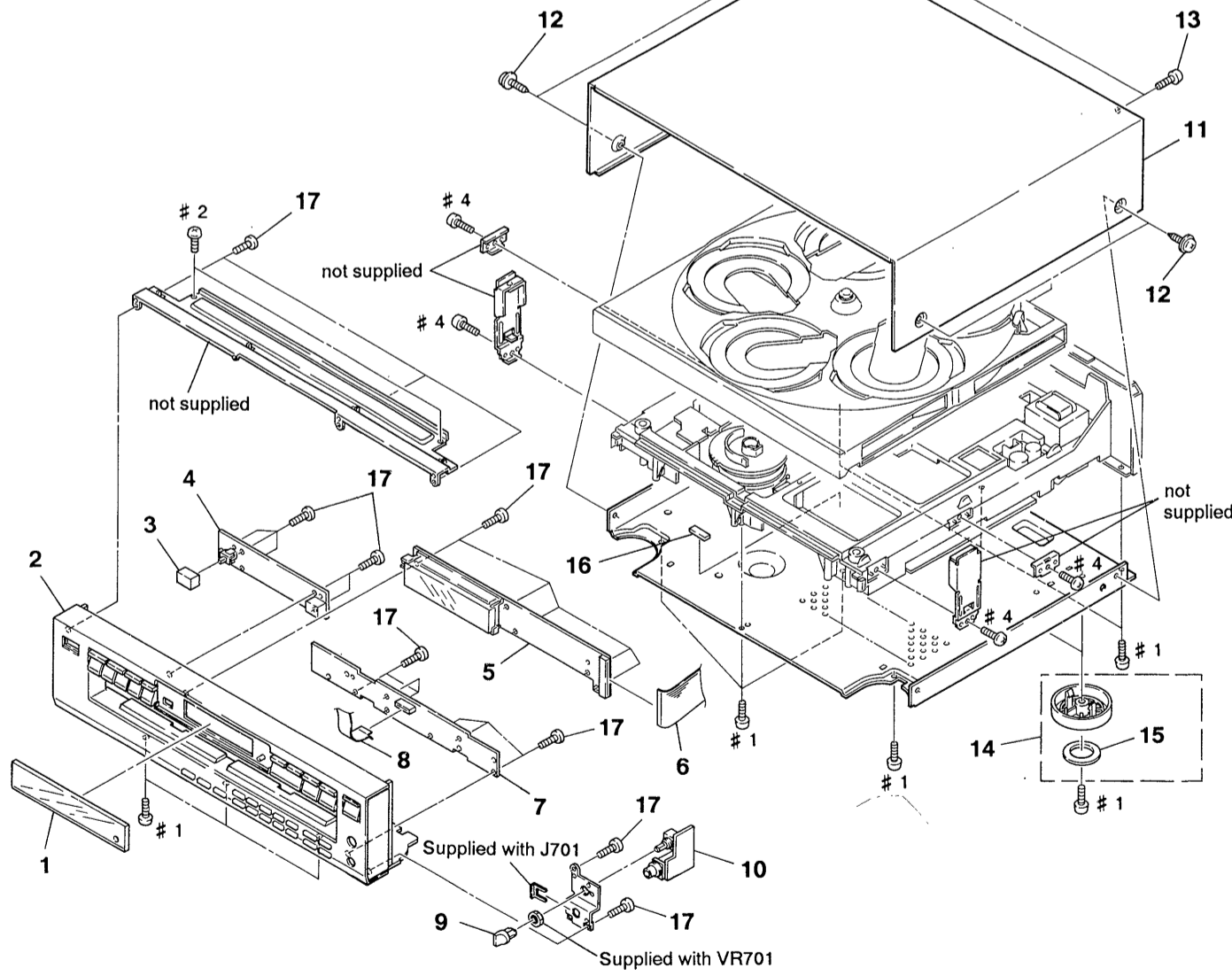

Ref. No.	Part No.	Description	Remark	Ref. No.	Part No.	Description	Remark
1	4-950-862-01	PLATE (FL), INDICATION		* 10	1-643-518-11	HEADPHONE BOARD	
2	X-4942-479-1	PANEL ASSY, FRONT (US, Canadian)		* 11	4-944-153-01	CASE	
3	X-4942-480-1	PANEL ASSY, FRONT (AEP, UK, E)		12	3-704-366-01	SCREW (CASE) (M3X8)	
4	4-922-921-01	BUTTON (POWER)		13	3-703-685-21	SCREW (18V 3X8)	
	1-643-516-11	POWER SW BOARD		14	X-4942-197-1	FOOT ASSY (US, Canadian)	
* 5	1-643-515-11	DISPLAY BOARD		14	X-4942-198-1	FOOT ASSY (AEP, UK, E)	
6	1-690-859-11	WIRE (FLAT TYPE) (33 CORE)		15	4-923-836-11	CUSHION	
* 7	1-643-517-11	FUNCTION BOARD		* 16	4-951-946-01	SHEET	
8	1-690-860-11	WIRE (FLAT TYPE) (12 CORE)		17	4-951-620-01	SCREW (2.6X8), BVTP	
9	4-950-169-01	KNOB (A) (VOL.)					

5-2. DISC TRAY ASSEMBLY

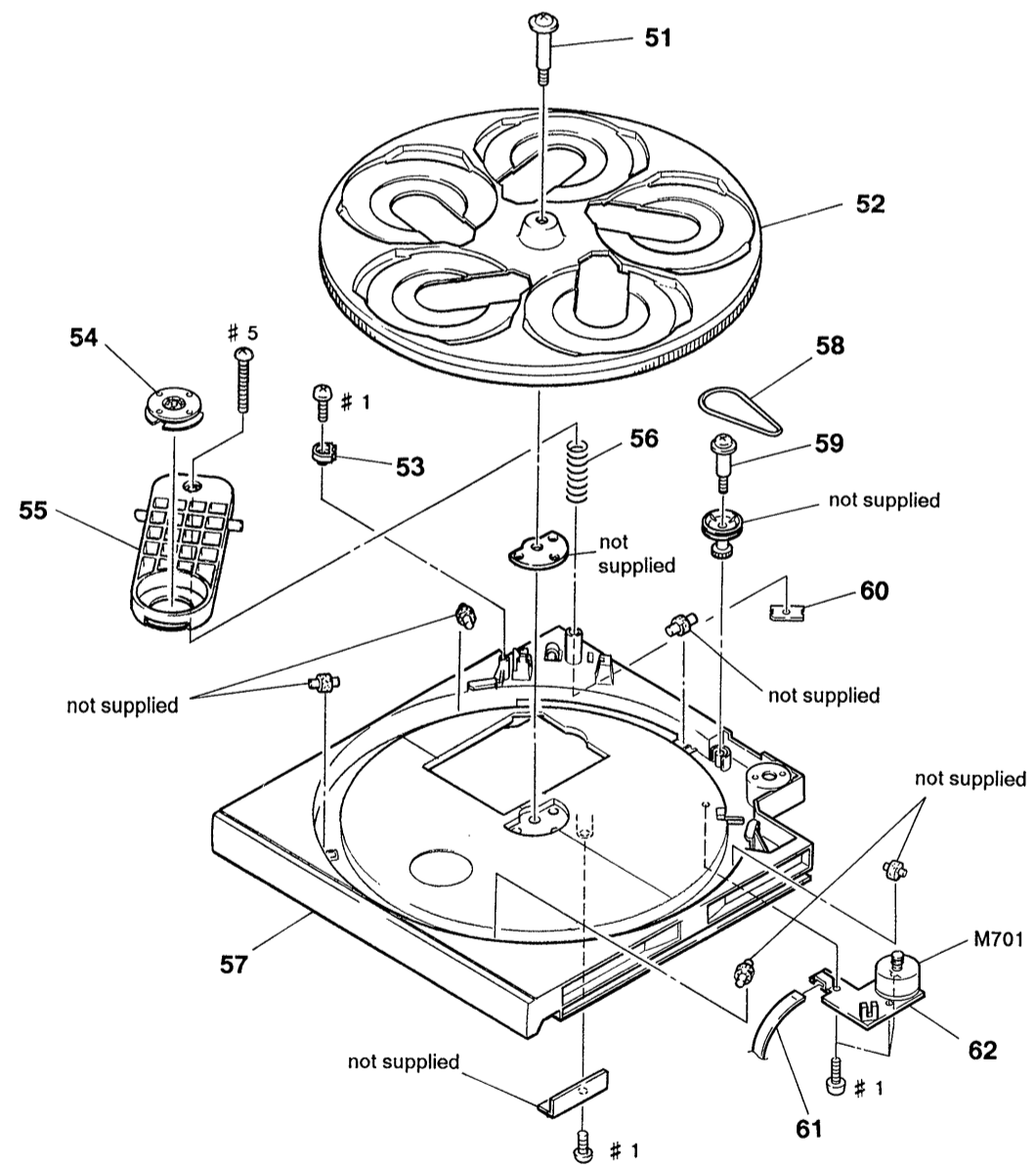

Ref. No.	Part No.	Description	Remark	Ref. No.	Part No.	Description	Remark
51	4-926-384-01	SCREW, STEP		58	4-926-399-01	BELT	
* 52	4-926-383-01	TABLE (B), DISK		59	4-923-697-01	SCREW, STEP	
* 53	4-949-226-01	PLATE, LOCK		* 60	4-926-388-01	BRACKET (ADJUSTMENT)	
* 54	1-452-538-11	MAGNET		61	1-590-849-11	WIRE, FLAT TYPE (5 CORE)	
* 55	4-930-506-02	BRACKET (PRESS PULLEY)		* 62	1-638-729-11	TABLE MOTOR BOARD	
				M701	A-4604-585-A	MOTOR ASSY, ROTARY (TABLE)	
56	4-926-395-01	SPRING, COMPRESSION					
57	4-950-866-01	TABLE (A), DISK					

5-3. CHASSIS ASSEMBLY

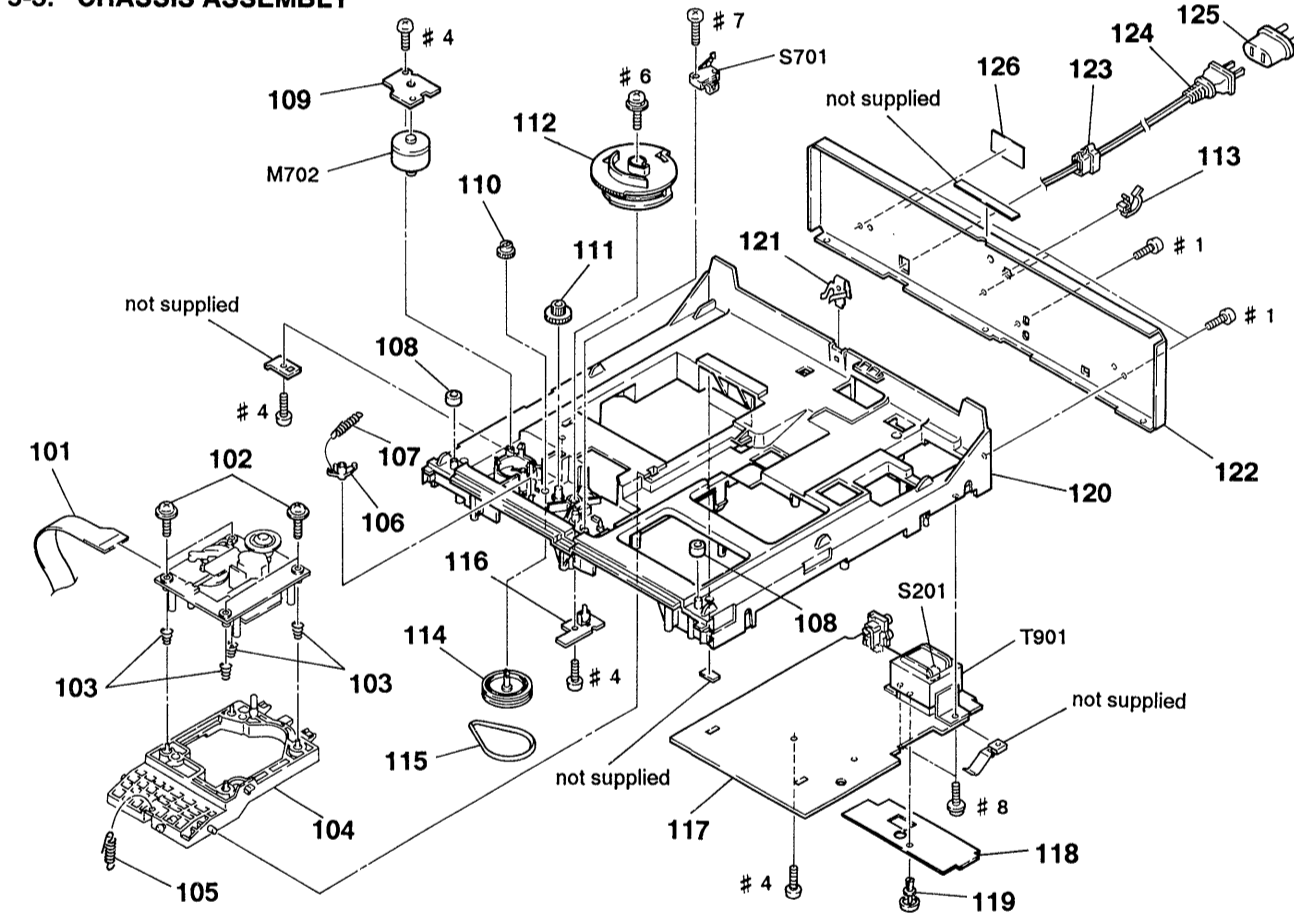

Ref. No.	Part No.	Description	Remark	Ref. No.	Part No.	Description	Remark
101	1-694-003-11	JAMPER, FILM (WITH TARMINAL)		* 120	4-943-997-01	CHASSIS	
102	4-933-134-01	SCREW (+PTPH M2.6X6)		* 121	4-943-996-01	SPRING, LEAF	
103	4-949-385-01	SPRING (D), COIL		* 122	4-949-994-01	PANEL, BACK (US, Canadian)	
* 104	4-934-373-01	BRACKET (BU)		* 122	4-949-994-21	PANEL, BACK (AEP)	
105	4-937-911-01	SPRING, TENSION		* 122	4-949-994-31	PANEL, BACK (E)	
106	4-917-519-01	LEVER, SET		* 122	4-949-994-41	PANEL, BACK (UK)	
107	4-924-412-01	SPRING (B), TENSION		* 123	3-703-244-00	BUSHING (2104), CORD (US, Canadian, AEP, UK)	
* 108	4-951-619-01	CUSHION (A)		* 123	3-703-571-11	BUSHING (S) (4516), CORD (E)	
* 109	1-638-730-11	LOADING MOTOR BOARD		* 124	1-558-946-21	CORD, POWER (UK)	
110	4-934-375-01	GEAR (LOADING B)		Δ 124	1-575-651-21	CORD, POWER (AEP)	
111	4-934-381-01	GEAR (LOADING C)		Δ 124	1-575-653-21	CORD, POWER (E)	
112	4-934-391-01	GEAR (LOADING A)		Δ 124	1-590-836-11	CORD, POWER (US, Canadian)	
* 113	4-949-235-01	HOOK		Δ 125	1-569-007-11	ADAPTER, CONVERSION 2P (E)	
114	X-4941-529-1	PULLEY ASSY		* 126	4-941-548-01	LABEL, CLASS 1 (AEP, UK, E)	
115	4-944-490-01	BELT (TIMING)					
				M702	A-4604-834-A	MOTOR ASSY, LOADING	
* 116	1-638-731-11	OPEN/UP SW BOARD		Δ S201	1-571-722-11	SWITCH, VOLTAGE SELECTION (E)	
* 117	A-4649-211-A	MAIN BOARD, COMPLETE (E)		S701	1-572-713-11	SWITCH, PUSH (WITH CONNECTOR) (DOWN)	
* 117	A-4649-214-A	MAIN BOARD, COMPLETE (US, Canadian)		Δ T901	1-449-955-11	TRANSFORMER, POWER (AEP, UK)	
* 117	A-4649-220-A	MAIN BOARD, COMPLETE (AEP, UK)		Δ T901	1-449-956-11	TRANSFORMER, POWER (E)	
* 118	4-944-178-01	SHEET (INSULATING)		Δ T901	1-450-876-11	TRANSFORMER, POWER (US, Canadian)	
119	3-531-576-11	RIVET					

The components identified by mark Δ or dotted line with mark Δ are critical for safety. Replace only with part number specified.
 Les composants identifiés par une marque Δ sont critiques pour la sécurité. Ne les remplacer que par une pièce portant le numéro spécifié.

5-4. OPTICAL PICK-UP BLOCK ASSEMBLY (BU-5BD8B)

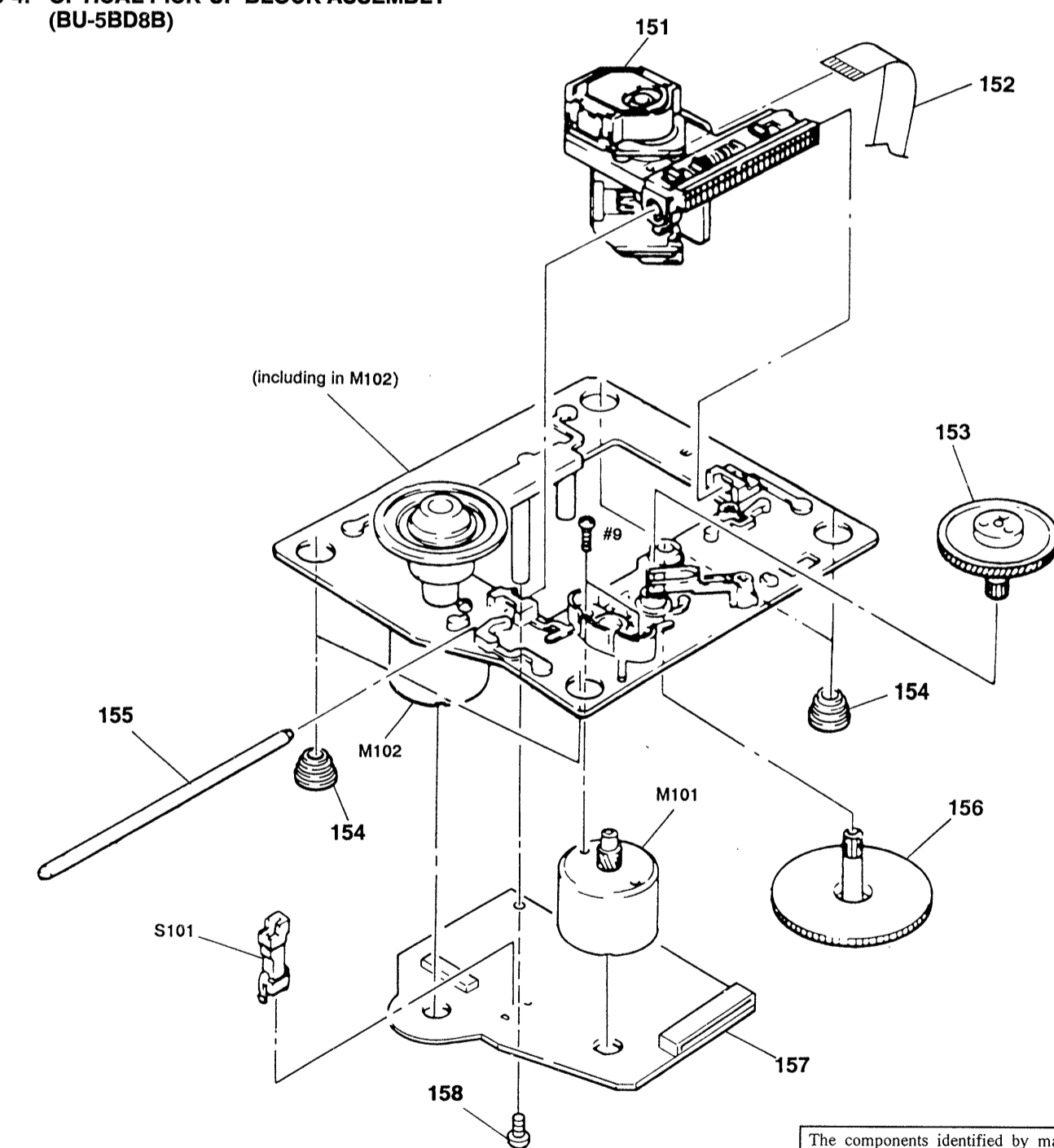

Ref. No.	Part No.	Description	Remark	Ref. No.	Part No.	Description	Remark
Δ 151	8-848-144-11	DEVICE, OPTICAL KSS-240A		* 157	A-4649-199-A	BD BOARD, COMPLETE	
152	1-575-001-11	WIRE, FLAT TYPE (12 CORE)		158	4-951-620-01	SCREW (2.6X8), BVTP	
153	4-917-567-01	GEAR (M)		M101	X-4917-504-1	MOTOR ASSY (SLED)	
154	4-951-940-01	INSULATOR (BU)		M102	X-4917-523-3	BASE (OUTSERT) ASSY (SPINDLE MOTOR)	
155	4-917-565-01	SHAFT, SLED		S101	1-572-085-11	SWITCH, LEAF (LIMIT IN)	
156	4-917-564-01	GEAR (P), FLATNESS					

The components identified by mark Δ or dotted line with mark Δ are critical for safety. Replace only with part number specified.
 Les composants identifiés par une marque Δ sont critiques pour la sécurité. Ne les remplacer que par une pièce portant le numéro spécifié.

SECTION 6 ELECTRICAL PARTS LIST

BD **MAIN**

NOTE:

The components identified by mark Δ or dotted line with mark Δ are critical for safety.
Replace only with part number specified.

Les composants identifiés par une marque Δ sont critiques pour la sécurité.
Ne les remplacer que par une pièce portant le numéro spécifié.

When indicating parts by reference number, please include the board name.

- Due to standardization, replacements in the parts list may be different from the parts specified in the diagrams or the components used on the set.
- -XX, -X mean standardized parts, so they may have some difference from the original one.
- RESISTORS
All resistors are in ohms
METAL: Metal-film resistor
METAL OXIDE: Metal Oxide-film resistor
F : nonflammable
- Items marked "*" are not stocked since they are seldom required for routine service. Some delay should be anticipated when ordering these items.
- SEMICONDUCTORS
In each case, u: μ , for example:
uA...: μ A..., uPA...: μ PA...,
uPB...: μ PB..., uPC...: μ PC...,
uPD...: μ PD...
- CAPACITORS
uF : μ F
- COILS
uH : μ H

Ref. No.	Part No.	Description	Remark	Ref. No.	Part No.	Description	Remark
*	A-4649-199-A	BD BOARD, COMPLETE *****		R112	1-216-049-00	METAL CHIP 1K 5% 1/10W	
		< CAPACITOR >		R113	1-216-077-00	METAL CHIP 15K 5% 1/10W	
C101	1-163-005-11	CERAMIC CHIP 470PF	10% 50V	R114	1-216-077-00	METAL CHIP 15K 5% 1/10W	
C102	1-163-038-00	CERAMIC CHIP 0.1uF	25V	R117	1-216-077-00	METAL CHIP 15K 5% 1/10W	
C103	1-163-005-11	CERAMIC CHIP 470PF	10% 50V	R118	1-216-077-00	METAL CHIP 15K 5% 1/10W	
C104	1-164-505-11	CERAMIC CHIP 2.2uF	16V	R121	1-216-077-00	METAL CHIP 15K 5% 1/10W	
C105	1-135-155-21	TANTALUM CHIP 4.7uF	10% 16V	R122	1-216-077-00	METAL CHIP 15K 5% 1/10W	
C106	1-164-346-11	CERAMIC CHIP 1uF	16V	R151	1-216-070-00	METAL CHIP 7.5K 5% 1/10W	
C107	1-164-505-11	CERAMIC CHIP 2.2uF	16V	R152	1-216-070-00	METAL CHIP 7.5K 5% 1/10W	
C108	1-164-346-11	CERAMIC CHIP 1uF	16V	R153	1-216-070-00	METAL CHIP 7.5K 5% 1/10W	
C112	1-163-038-00	CERAMIC CHIP 0.1uF	25V	R154	1-216-070-00	METAL CHIP 7.5K 5% 1/10W	
C151	1-163-007-11	CERAMIC CHIP 680PF	10% 50V	R155	1-216-070-00	METAL CHIP 7.5K 5% 1/10W	
C152	1-163-007-11	CERAMIC CHIP 680PF	10% 50V	R156	1-216-070-00	METAL CHIP 7.5K 5% 1/10W	
C153	1-163-038-00	CERAMIC CHIP 0.1uF	25V	R157	1-216-085-00	METAL CHIP 33K 5% 1/10W	
C154	1-164-336-11	CERAMIC CHIP 0.33uF	25V	R158	1-216-076-00	METAL CHIP 13K 5% 1/10W	
C155	1-163-007-11	CERAMIC CHIP 680PF	10% 50V	R159	1-216-085-00	METAL CHIP 33K 5% 1/10W	
C156	1-163-007-11	CERAMIC CHIP 680PF	10% 50V	R160	1-216-081-00	METAL CHIP 22K 5% 1/10W	
C157	1-163-037-11	CERAMIC CHIP 0.022uF	10% 25V	R161	1-216-093-00	METAL CHIP 68K 5% 1/10W	
C158	1-163-037-11	CERAMIC CHIP 0.022uF	10% 25V	R162	1-216-085-00	METAL CHIP 33K 5% 1/10W	
C159	1-163-023-00	CERAMIC CHIP 0.015uF	5% 50V	R163	1-216-308-00	METAL CHIP 4.7 5% 1/10W	
C160	1-163-019-00	CERAMIC CHIP 0.0068uF	10% 50V			< SWITCH >	
C181	1-163-038-00	CERAMIC CHIP 0.1uF	25V	S101	1-572-085-11	SWITCH, LEAF (LIMIT)	
		< CONNECTOR >		*****			
CN101	1-568-861-11	SOCKET, CONNECTOR 18P		*	A-4649-214-A	MAIN BOARD, COMPLETE (US, Canadian)	*****
CN102	1-568-795-11	SOCKET, CONNECTOR 12P					
		< IC >		*	A-4649-220-A	MAIN BOARD, COMPLETE (AEP, UK)	*****
IC101	8-752-344-48	IC CXD2501Q					
IC102	8-759-071-80	IC BA6297AFP-T1		*	A-4649-211-A	MAIN BOARD, COMPLETE (E)	*****
		< RESISTOR >					
R101	1-216-077-00	METAL CHIP 15K 5% 1/10W			7-682-547-04	SCREW +BVTT 3X6 (S)	
R102	1-216-097-00	METAL CHIP 100K 5% 1/10W					
R103	1-216-077-00	METAL CHIP 15K 5% 1/10W					
R104	1-216-085-00	METAL CHIP 33K 5% 1/10W					
R105	1-216-097-00	METAL CHIP 100K 5% 1/10W					

MAIN

Ref. No.	Part No.	Description	Remark	Ref. No.	Part No.	Description	Remark
< CAPACITOR >							
C201	1-124-572-11	ELECT	100uF 20% 63V	C356	1-126-022-11	ELECT	47uF 20% 16V
C202	1-126-059-11	ELECT	10uF 20% 50V	C357	1-124-997-11	ELECT	470uF 20% 10V
C203	1-124-556-11	ELECT	2200uF 20% 16V	C358	1-161-494-00	CERAMIC	0.022uF 25V
C204	1-124-887-00	ELECT	3300uF 20% 16V	C361	1-162-280-31	CERAMIC	82PF 10% 50V
C205	1-126-163-11	ELECT	4.7uF 20% 50V	C363	1-162-213-31	CERAMIC	39PF 5% 50V
C206	1-126-163-11	ELECT	4.7uF 20% 50V	C364	1-162-213-31	CERAMIC	39PF 5% 50V
C207	1-124-910-11	ELECT	47uF 20% 50V	C365	1-162-213-31	CERAMIC	39PF 5% 50V
C209	1-124-997-11	ELECT	470uF 20% 10V	C366	1-162-213-31	CERAMIC	39PF 5% 50V
C210	1-126-024-11	ELECT	220uF 20% 16V	C367	1-162-280-31	CERAMIC	82PF 10% 50V
C221	1-161-494-00	CERAMIC	0.022uF 25V	C371	1-130-479-00	MYLAR	0.0047uF 5% 50V
C230	1-126-049-11	ELECT	22uF 20% 25V	C372	1-130-479-00	MYLAR	0.0047uF 5% 50V
C231	1-124-994-11	ELECT	100uF 20% 10V	C373	1-130-472-00	MYLAR	0.0012uF 5% 50V
C232	1-124-994-11	ELECT	100uF 20% 10V	C374	1-130-472-00	MYLAR	0.0012uF 5% 50V
C233	1-126-012-11	ELECT	470uF 20% 16V	C375	1-124-994-11	ELECT	100uF 20% 10V
C234	1-126-012-11	ELECT	470uF 20% 16V	C376	1-124-994-11	ELECT	100uF 20% 10V
C301	1-126-022-11	ELECT	47uF 20% 16V	C377	1-124-994-11	ELECT	100uF 20% 10V
C302	1-161-494-00	CERAMIC	0.022uF 25V	C378	1-124-994-11	ELECT	100uF 20% 10V
C303	1-161-494-00	CERAMIC	0.022uF 25V	C379	1-130-473-00	MYLAR	0.0015uF 5% 50V
C304	1-164-159-11	CERAMIC	0.1uF 50V	C380	1-130-473-00	MYLAR	0.0015uF 5% 50V
C311	1-136-161-00	FILM	0.047uF 5% 50V	C384	1-126-022-11	ELECT	47uF 20% 16V
C312	1-161-374-11	CERAMIC	0.0015uF 20% 50V	C385	1-126-022-11	ELECT	47uF 20% 16V
C313	1-161-494-00	CERAMIC	0.022uF 25V	C390	1-161-494-00	CERAMIC	0.022uF 25V
C314	1-162-306-11	CERAMIC	0.01uF 20% 16V	C391	1-124-997-11	ELECT	470uF 20% 10V
C315	1-126-300-11	ELECT	0.47uF 20% 50V	C392	1-164-159-11	CERAMIC	0.1uF 50V
C316	1-161-494-00	CERAMIC	0.022uF 25V	C393	1-164-159-11	CERAMIC	0.1uF 50V
C319	1-162-282-31	CERAMIC	100PF 10% 50V	C394	1-164-159-11	CERAMIC	0.1uF 50V
C320	1-130-483-00	MYLAR	0.01uF 5% 50V	C395	1-164-159-11	CERAMIC	0.1uF 50V
C322	1-164-159-11	CERAMIC	0.1uF 50V	C401	1-126-022-11	ELECT	47uF 20% 16V
C331	1-162-208-31	CERAMIC	24PF 5% 50V	C402	1-161-494-00	CERAMIC	0.022uF 25V
C336	1-126-022-11	ELECT	47uF 20% 16V	C403	1-126-023-11	ELECT	100uF 20% 16V
C337	1-161-494-00	CERAMIC	0.022uF 25V	C404	1-126-023-11	ELECT	100uF 20% 16V
C342	1-126-022-11	ELECT	47uF 20% 16V	C408	1-164-159-11	CERAMIC	0.1uF 50V
C343	1-161-494-00	CERAMIC	0.022uF 25V	C409	1-164-159-11	CERAMIC	0.1uF 50V
C349	1-161-494-00	CERAMIC	0.022uF 25V	C414	1-161-494-00	CERAMIC	0.022uF 25V
C350	1-126-022-11	ELECT	47uF 20% 16V	C425	1-162-294-31	CERAMIC	0.001uF 10% 50V
C351	1-161-494-00	CERAMIC	0.022uF 25V	C426	1-162-294-31	CERAMIC	0.001uF 10% 50V
C352	1-164-159-11	CERAMIC	0.1uF 50V	C427	1-162-294-31	CERAMIC	0.001uF 10% 50V
C353	1-162-205-31	CERAMIC	18PF 5% 50V	C428	1-162-294-31	CERAMIC	0.001uF 10% 50V
C354	1-162-205-31	CERAMIC	18PF 5% 50V	C429	1-162-294-31	CERAMIC	0.001uF 10% 50V
C355	1-161-494-00	CERAMIC	0.022uF 25V	C430	1-162-294-31	CERAMIC	0.001uF 10% 50V
				C431	1-162-294-31	CERAMIC	0.001uF 10% 50V
				C432	1-162-294-31	CERAMIC	0.001uF 10% 50V

MAIN

Ref. No.	Part No.	Description	Remark	Ref. No.	Part No.	Description	Remark
C550	1-126-024-11	ELECT	220uF 20% 16V	L305	1-412-473-21	INDUCTOR	0uH
C560	1-126-024-11	ELECT	220uF 20% 16V	L306	1-412-297-11	INDUCTOR	3. 3uH
< CONNECTOR >							
* CN201	1-573-047-11	PIN, CONNECTOR (PC BOARD) 2P		L309	1-412-473-21	INDUCTOR	0uH
* CN301	1-691-895-11	SOCKET, CONNECTOR (L TYPE) 18P		L310	1-412-473-21	INDUCTOR	0uH
* CN401	1-691-901-11	SOCKET, CONNECTOR (L TYPE) 33P		L312	1-412-473-21	INDUCTOR	0uH
* CN402	1-691-891-11	SOCKET, CONNECTOR (L TYPE) 12P		L331	1-412-297-11	INDUCTOR	3. 3uH
* CN403	1-568-824-11	SOCKET, CONNECTOR 5P		< TRANSISTOR >			
* CN404	1-568-943-11	PIN, CONNECTOR 5P		Q201	8-729-119-76	TRANSISTOR	2SA1175-HFE
* CN501	1-568-941-11	PIN, CONNECTOR 3P		Q302	8-729-900-80	TRANSISTOR	DTC114ES
< DIODE >				Q303	8-729-900-89	TRANSISTOR	DTC144ES
D201	8-719-200-82	DIODE	11ES2	Q304	8-729-900-61	TRANSISTOR	DTA114ES
D202	8-719-110-08	DIODE	RD8, 2ES-B2	Q305	8-729-900-61	TRANSISTOR	DTA114ES
D203	8-719-200-82	DIODE	11ES2	< RESISTOR >			
D204	8-719-200-82	DIODE	11ES2	R201	1-249-435-11	CARBON	33K 5% 1/4W
D205	8-719-200-82	DIODE	11ES2	R202	1-249-438-11	CARBON	56K 5% 1/4W
D206	8-719-200-82	DIODE	11ES2	R203	1-249-429-11	CARBON	10K 5% 1/4W
D207	8-719-200-82	DIODE	11ES2 (AEP, UK, E)	R301	1-249-417-11	CARBON	1K 5% 1/4W
D208	8-719-200-82	DIODE	11ES2 (AEP, UK, E)	R302	1-249-417-11	CARBON	1K 5% 1/4W
D385	8-719-987-63	DIODE	1N4148M	R303	1-249-417-11	CARBON	1K 5% 1/4W
< IC >				R304	1-249-417-11	CARBON	1K 5% 1/4W
IC201	8-759-633-42	IC	M5293L	R306	1-249-413-11	CARBON	470 5% 1/4W
IC202	8-759-061-65	IC	LA5602	R309	1-249-405-11	CARBON	100 5% 1/4W
IC204	8-759-604-86	IC	M5F7807	R311	1-249-423-11	CARBON	3. 3K 5% 1/4W
IC301	8-752-337-26	IC	CXD2500AQ	R312	1-249-429-11	CARBON	10K 5% 1/4W
IC302	8-752-342-65	IC	CXD2560M	R313	1-249-423-11	CARBON	3. 3K 5% 1/4W
IC303	8-752-351-19	IC	CXD2561BM	R314	1-249-429-11	CARBON	10K 5% 1/4W
IC306	8-759-061-66	IC	LA9215	R315	1-249-417-11	CARBON	1K 5% 1/4W
IC401	8-752-834-31	IC	CXP50116-267Q	R316	1-249-417-11	CARBON	1K 5% 1/4W
IC402	8-759-821-32	IC	CXA1291P	R317	1-249-419-11	CARBON	1. 5K 5% 1/4W
IC501	8-759-634-51	IC	M5218AP	R318	1-249-441-11	CARBON	100K 5% 1/4W
< JACK >				R319	1-247-903-00	CARBON	1M 5% 1/4W
J501	1-569-442-11	JACK, PIN 2P (LINE OUT L/R)		R321	1-249-417-11	CARBON	1K 5% 1/4W
< COIL >				R322	1-249-417-11	CARBON	1K 5% 1/4W
L301	1-412-473-21	INDUCTOR	0uH	R323	1-249-417-11	CARBON	1K 5% 1/4W
L302	1-412-473-21	INDUCTOR	0uH	R324	1-249-417-11	CARBON	1K 5% 1/4W
L303	1-412-473-21	INDUCTOR	0uH	R330	1-249-417-11	CARBON	1K 5% 1/4W
				R331	1-249-417-11	CARBON	1K 5% 1/4W
				R342	1-249-417-11	CARBON	1K 5% 1/4W

MAIN

DISPLAY

POWER SW

FUNCTION

HEADPHONE

Ref. No.	Part No.	Description	Remark	Ref. No.	Part No.	Description	Remark
R351	1-249-436-11	CARBON	39K 5% 1/4W	R416	1-247-878-00	CARBON	91K 5% 1/4W
R352	1-249-436-11	CARBON	39K 5% 1/4W	R421	1-249-393-11	CARBON	10 5% 1/4W
R353	1-249-436-11	CARBON	39K 5% 1/4W	R422	1-249-393-11	CARBON	10 5% 1/4W
R354	1-249-436-11	CARBON	39K 5% 1/4W				
R355	1-249-436-11	CARBON	39K 5% 1/4W	R425	1-249-429-11	CARBON	10K 5% 1/4W
				R426	1-249-429-11	CARBON	10K 5% 1/4W
R356	1-249-436-11	CARBON	39K 5% 1/4W	R427	1-249-429-11	CARBON	10K 5% 1/4W
R357	1-249-436-11	CARBON	39K 5% 1/4W	R428	1-249-429-11	CARBON	10K 5% 1/4W
R358	1-249-436-11	CARBON	39K 5% 1/4W	R429	1-249-429-11	CARBON	10K 5% 1/4W
R359	1-247-903-00	CARBON	1M 5% 1/4W				
R361	1-249-431-11	CARBON	15K 5% 1/4W	R430	1-249-429-11	CARBON	10K 5% 1/4W
				R431	1-249-429-11	CARBON	10K 5% 1/4W
R362	1-249-431-11	CARBON	15K 5% 1/4W	R432	1-249-429-11	CARBON	10K 5% 1/4W
R363	1-249-431-11	CARBON	15K 5% 1/4W	R553	1-249-402-11	CARBON	56 5% 1/4W
R364	1-249-431-11	CARBON	15K 5% 1/4W	R563	1-249-402-11	CARBON	56 5% 1/4W
R365	1-249-438-11	CARBON	56K 5% 1/4W				
R366	1-249-438-11	CARBON	56K 5% 1/4W				
R367	1-249-438-11	CARBON	56K 5% 1/4W				
R368	1-249-438-11	CARBON	56K 5% 1/4W				
R369	1-249-419-11	CARBON	1. 5K 5% 1/4W				
R370	1-249-419-11	CARBON	1. 5K 5% 1/4W				
R371	1-249-419-11	CARBON	1. 5K 5% 1/4W				
R372	1-249-419-11	CARBON	1. 5K 5% 1/4W				
R373	1-249-429-11	CARBON	10K 5% 1/4W				
R374	1-249-429-11	CARBON	10K 5% 1/4W				
R375	1-249-429-11	CARBON	10K 5% 1/4W				
R376	1-249-429-11	CARBON	10K 5% 1/4W				
R383	1-249-417-11	CARBON	1K 5% 1/4W				
R384	1-249-417-11	CARBON	1K 5% 1/4W				
R385	1-249-422-11	CARBON	2. 7K 5% 1/4W				
R401	1-249-433-11	CARBON	22K 5% 1/4W				
R402	1-249-433-11	CARBON	22K 5% 1/4W				
R403	1-249-425-11	CARBON	4. 7K 5% 1/4W				
R404	1-249-425-11	CARBON	4. 7K 5% 1/4W				
R405	1-249-425-11	CARBON	4. 7K 5% 1/4W				
R406	1-249-425-11	CARBON	4. 7K 5% 1/4W				
R408	1-249-441-11	CARBON	100K 5% 1/4W				
R409	1-247-864-11	CARBON	24K 5% 1/4W				
R410	1-247-880-11	CARBON	110K 5% 1/4W				
R411	1-249-440-11	CARBON	82K 5% 1/4W				
R412	1-247-876-11	CARBON	75K 5% 1/4W				
R413	1-249-440-11	CARBON	82K 5% 1/4W				
R414	1-247-874-11	CARBON	62K 5% 1/4W				
R415	1-249-435-11	CARBON	33K 5% 1/4W				

< SWITCH >

△S201 1-571-722-11 SWITCH, VOLTAGE SELECTION (E)

< CRYSTAL >

X351 1-579-314-11 VIBRATOR, CRYSTAL (22.5MHz)

* 1-643-515-11 DISPLAY BOARD

* 1-643-516-11 POWER SW BOARD

* 1-643-517-11 FUNCTION BOARD

* 1-643-518-11 HEADPHONE BOARD

* 1-690-880-31 READ (WITH CONNECTOR)

* 4-950-864-01 HOLDER (FL)

< CAPACITOR >

C701 1-162-291-31 CERAMIC 560PF 10% 50V

C702 1-162-291-31 CERAMIC 560PF 10% 50V

C703 1-164-159-11 CERAMIC 0.1uF 50V

C704 1-161-494-00 CERAMIC 0.022uF 25V

< CONNECTOR >

* CN704 1-691-890-11 SOCKET, CONNECTOR (S TYPE) 12P

* CN705 1-691-901-11 SOCKET, CONNECTOR (L TYPE) 33P

The components identified by mark △ or dotted line with mark △ are critical for safety. Replace only with part number specified.

Les composants identifiés par une marque △ sont critiques pour la sécurité. Ne les remplacer que par une pièce portant le numéro spécifié.



DISPLAY

POWER SW

FUNCTION

HEADPHONE

Ref. No.	Part No.	Description	Remark	Ref. No.	Part No.	Description	Remark
		< FILTER >		R728	1-249-422-11	CARBON 2.7K 5% 1/4W	
FL701	1-519-721-11	INDICATOR TUBE, FLUORESCENT				< SWITCH >	
		< IC >		S701	1-554-303-21	SWITCH, TACTILE (REPEAT)	
IC701	8-741-100-48	IC SBX1610-59		S702	1-554-303-21	SWITCH, TACTILE (PROGRAM)	
		< JACK >		S703	1-554-303-21	SWITCH, TACTILE (SHUFFLE)	
J701	1-568-519-41	JACK, LARGE TYPE (PHONES)		S704	1-554-303-21	SWITCH, TACTILE (CONTINUE)	
		< COIL >		S705	1-554-303-21	SWITCH, TACTILE (DISC 5)	
L703	1-412-473-21	INDUCTOR 0uH		S706	1-554-303-21	SWITCH, TACTILE (DISC 4)	
		< RESISTOR >		S707	1-554-303-21	SWITCH, TACTILE (DISC 3)	
R701	1-249-422-11	CARBON 2.7K 5% 1/4W		S708	1-554-303-21	SWITCH, TACTILE (DISC 2)	
R702	1-249-424-11	CARBON 3.9K 5% 1/4W		S709	1-554-303-21	SWITCH, TACTILE (DISC 1)	
R703	1-249-427-11	CARBON 6.8K 5% 1/4W		S710	1-572-714-11	SWITCH, PUSH (POWER ON/OFF)	
R704	1-249-422-11	CARBON 2.7K 5% 1/4W		S711	1-554-303-21	SWITCH, TACTILE (CHECK)	
R705	1-249-424-11	CARBON 3.9K 5% 1/4W		S712	1-554-303-21	SWITCH, TACTILE (EDIT/TIME FADER)	
R706	1-249-427-11	CARBON 6.8K 5% 1/4W		S713	1-554-303-21	SWITCH, TACTILE (5)	
R707	1-249-432-11	CARBON 18K 5% 1/4W		S714	1-554-303-21	SWITCH, TACTILE (4)	
R708	1-249-424-11	CARBON 3.9K 5% 1/4W		S715	1-554-303-21	SWITCH, TACTILE (3)	
R709	1-249-422-11	CARBON 2.7K 5% 1/4W		S716	1-554-303-21	SWITCH, TACTILE (2)	
R710	1-249-427-11	CARBON 6.8K 5% 1/4W		S717	1-554-303-21	SWITCH, TACTILE (1)	
R711	1-249-432-11	CARBON 18K 5% 1/4W		S718	1-554-303-21	SWITCH, TACTILE (CLEAR)	
R712	1-249-422-11	CARBON 2.7K 5% 1/4W		S719	1-554-303-21	SWITCH, TACTILE (>10)	
R713	1-249-424-11	CARBON 3.9K 5% 1/4W		S720	1-554-303-21	SWITCH, TACTILE (10)	
R714	1-249-427-11	CARBON 6.8K 5% 1/4W		S721	1-554-303-21	SWITCH, TACTILE (9)	
R715	1-249-432-11	CARBON 18K 5% 1/4W		S722	1-554-303-21	SWITCH, TACTILE (8)	
R716	1-249-422-11	CARBON 2.7K 5% 1/4W		S723	1-554-303-21	SWITCH, TACTILE (7)	
R717	1-249-424-11	CARBON 3.9K 5% 1/4W		S724	1-554-303-21	SWITCH, TACTILE (6)	
R718	1-249-427-11	CARBON 6.8K 5% 1/4W		S725	1-554-303-21	SWITCH, TACTILE (FADER)	
R719	1-249-432-11	CARBON 18K 5% 1/4W		S726	1-554-303-21	SWITCH, TACTILE (PEAK SEARCH)	
R720	1-249-422-11	CARBON 2.7K 5% 1/4W		S727	1-554-303-21	SWITCH, TACTILE (MUSIC SCAN)	
R721	1-249-432-11	CARBON 18K 5% 1/4W		S728	1-554-303-21	SWITCH, TACTILE (DISC SKIP)	
R722	1-249-432-11	CARBON 18K 5% 1/4W		S729	1-554-303-21	SWITCH, TACTILE (▶▶)	
R723	1-249-427-11	CARBON 6.8K 5% 1/4W		S730	1-554-303-21	SWITCH, TACTILE (◀◀)	
R724	1-249-424-11	CARBON 3.9K 5% 1/4W		S731	1-554-303-21	SWITCH, TACTILE (◀▶)	
R725	1-249-422-11	CARBON 2.7K 5% 1/4W		S732	1-554-303-21	SWITCH, TACTILE (▶◀)	
R726	1-249-427-11	CARBON 6.8K 5% 1/4W		S733	1-554-303-21	SWITCH, TACTILE (OPEN/CLOSE △)	
R727	1-249-424-11	CARBON 3.9K 5% 1/4W		S734	1-554-303-21	SWITCH, TACTILE (■)	
				S735	1-554-303-21	SWITCH, TACTILE (▣)	
				S736	1-554-303-21	SWITCH, TACTILE (▷)	
				S737	1-554-303-21	SWITCH, TACTILE (TIME)	

The components identified by mark  or dotted line with mark  are critical for safety. Replace only with part number specified.

Les composants identifiés par une marque  sont critiques pour la sécurité. Ne les remplacer que par une pièce portant le numéro spécifié.

DISPLAY **POWER SW** **FUNCTION** **HEADPHONE**
TABLE MOTOR **LOADING MOTOR** **OPEN/UP SW**

Ref.No.	Part No.	Description	Remark	Ref.No.	Part No.	Description	Remark
		< VARIABLE RESISTOR >					
VR701	1-241-506-11	RES, VAR, CARBON 1K/1K (PHONE LEVEL)		152	1-575-001-11	WIRE, FLAT TYPE (12 CORE)	
		*****		6	1-690-859-11	WIRE (FLAT TYPE) (33 CORE)	
*	1-638-729-11	TABLE MOTOR BOARD		8	1-690-860-11	WIRE (FLAT TYPE) (12 CORE)	
		*****		* 54	1-452-538-11	MAGNET	
*	1-638-730-11	LOADING MOTOR BOARD		61	1-590-849-11	WIRE, FLAT TYPE (5 CORE)	
		*****		M101	X-4917-504-1	MOTOR ASSY (SLED)	
*	1-638-731-11	OPEN/UP SW BOARD		M102	X-4917-523-3	BASE (OUTSERT) ASSY (SPINDLE MOTOR)	
		*****		M701	A-4604-585-A	MOTOR ASSY, ROTARY (TABLE)	
		< CAPACITOR >		M702	A-4604-834-A	MOTOR ASSY, LOADING	
C704	1-161-375-00	CERAMIC 0.0022uF 20% 50V		S701	1-572-713-11	SWITCH, PUSH (WITH CONNECTOR) (DOWN)	
C705	1-161-375-00	CERAMIC 0.0022uF 20% 50V		△T901	1-449-955-11	TRANSFORMER, POWER (AEP, UK)	
		< CONNECTOR >		△T901	1-449-956-11	TRANSFORMER, POWER (E)	
		*****		△T901	1-450-876-11	TRANSFORMER, POWER (US, Canadian)	
* CN705	1-573-383-11	PIN, CONNECTOR (PC BOARD) 2P				*****	
* CN707	1-573-044-11	SOCKET, CONNECTOR 5P				ACCESSORIES & PACKING MATERIALS	
		< DIODE >				*****	
D701	8-719-970-19	DIODE GP-1A521				1-558-271-11	CORD, CONNECTION
		< RESISTOR >				1-693-053-11	REMOTE COMMANDER (RM-D325)
R701	1-249-416-11	CARBON 820 5% 1/4W				2-181-754-01	COVER, BATTERY
		< SWITCH >				3-754-820-11	MANUAL, INSTRUCTION (AEP, UK, E) (ENGLISH, FRENCH, SPANISH, PORTUGUESE)
S702	1-571-300-21	SWITCH, ROTARY (OPEN/UP)				3-754-820-21	MANUAL, INSTRUCTION (ENGLISH) (US, Canadian)
		*****				3-754-820-31	MANUAL, INSTRUCTION (FRENCH) (Canadian)
		MISCELLANEOUS				3-754-820-41	MANUAL, INSTRUCTION (AEP) (GERMAN, DUTCH, SWEDISH, ITALIAN)
		*****				3-795-629-11	INSTRUCTION (AEP)
101	1-694-003-11	JAMPER, FILM (WITH TARMINAL)				4-937-945-01	PLATE (TRANSPORT), LOCK
△124	1-558-946-21	CORD, POWER (UK)		*		4-941-548-01	LABEL, CLASS 1 (AEP, UK, E)
△124	1-575-651-21	CORD, POWER (AEP)		*		4-944-110-01	CUSHION (FRONT)
△124	1-575-653-21	CORD, POWER (E)		*		4-944-111-01	CUSHION (REAR)
△124	1-590-836-11	CORD, POWER (US, Canadian)		*		4-949-235-01	HOOK
		*****		*		4-951-752-01	INDIVIDUAL CARTON
△125	1-569-007-11	ADAPTER, CONVERSION 2P (E)				*****	
△151	8-848-144-11	DEVICE, OPTICAL KSS-240A				HARDWARE LIST	
		*****				*****	
		*****		# 1	7-685-647-79	SCREW +BVTP 3X10 TYPE2 N-S	

The components identified by mark △ or dotted line with mark △ are critical for safety. Replace only with part number specified.

Les composants identifiés par une marque △ sont critiques pour la sécurité. Ne les remplacer que par une pièce portant le numéro spécifié.

<u>Ref. No.</u>	<u>Part No.</u>	<u>Description</u>	<u>Remark</u>
# 2	7-682-548-04	SCREW +BVTT 3X8 (S)	
# 4	7-685-646-79	SCREW +BVTP 3X8 TYPE2 N-S	
# 5	7-682-554-04	SCREW +B 3X25	
# 6	7-682-661-09	SCREW +PSW 4X8	
# 7	7-685-136-19	SCREW +P 2. 6X12 TYPE2 NON-SLIT	
# 8	7-685-647-79	SCREW, TAPPING	
# 9	7-621-255-15	SCREW +P 2X3	
#10	7-682-547-04	SCREW +BVTT 3X6 (S)	

