

CDP-CE275/CE375

SERVICE MANUAL

Ver 1.1 2001.07

US Model
Canadian Model
Australian Model
CDP-CE275/CE375
AEP Model
UK Model
E Model
CDP-CE375



Photo: CDP-CE375

Model Name Using Similar Mechanism	CDP-CE345
CD Mechanism Type	CDM59-5BD27
Base Unit Name	BU-5BD27
Optical Pick-up Name	PXR-104X

SPECIFICATIONS

Compact disc player

Laser	Semiconductor laser ($\lambda = 780 \text{ nm}$) Emission duration : continuous
Frequency response	2 Hz to 20 kHz $\pm 0.5 \text{ dB}$
Dynamic range	More than 93 dB
Harmonic distortion	Less than 0.0045%

Outputs

	Jack type	Maximum output level	Load impedance
ANALOG OUT	Phono jacks	2 V (at 50 kilohms)	Over 10 kilohms
DIGITAL OUT (OPTICAL)	Optical output connector	-18 dBm	Wave length: 660 nm
PHONES (CDP-CE375 only)	Stereo phone jack	10 mW	32 ohms

General

Power requirements	120 V AC, 60 Hz
Power consumption	11 W
Dimensions (approx.) (w/h/d)	430 x 110 x 400 mm (17 x 4 3/8 x 15 3/4 in.) incl. projecting parts
Mass (approx.)	5 kg (11 lbs 1 oz)

Supplied accessories

Audio cord (2 phono plugs – 2 phono plugs) (1)
Remote commander (remote) (1) (CDP-CE375 only)
R6 (size AA) batteries (2) (CDP-CE375 only)

Design and specifications are subject to change without notice.

COMPACT DISC PLAYER

9-873-822-12
2001G0500-1
© 2001.7

Sony Corporation
Home Audio Company
Shinagawa Tec Service Manual Production Group

SONY®

TABLE OF CONTENTS

1. SERVICING NOTES	3
2. GENERAL	4
3. DISASSEMBLY	5
4. TEST MODE	10
5. ELECTRICAL ADJUSTMENTS	13
6. DIAGRAMS	
6-1. Note for Printed Wiring Boards and Schematic Diagrams	15
6-2. Printed Wiring Board – BD Board –	16
6-3. Schematic Diagram – BD Board –	17
6-4. Printed Wiring Boards – JUNCTION/SENSOR/ LOADING MOTOR Boards –	18
6-5. Schematic Diagram – JUNCTION/SENSOR/ LOADING MOTOR Boards –	19
6-6. Printed Wiring Board – MAIN Board –	20
6-7. Schematic Diagram – MAIN Board –	21
6-8. Printed Wiring Boards – PANEL Section –	22
6-9. Schematic Diagram – PANEL Section –	23
6-10. IC Pin Function Description	26
7. EXPLODED VIEWS	30
8. ELECTRICAL PARTS LIST	35

SAFETY CHECK-OUT

After correcting the original service problem, perform the following safety check before releasing the set to the customer: Check the antenna terminals, metal trim, “metallized” knobs, screws, and all other exposed metal parts for AC leakage. Check leakage as described below.

LEAKAGE TEST

The AC leakage from any exposed metal part to earth ground and from all exposed metal parts to any exposed metal part having a return to chassis, must not exceed 0.5 mA (500 microamperes.). Leakage current can be measured by any one of three methods.

1. A commercial leakage tester, such as the Simpson 229 or RCA WT-540A. Follow the manufacturers’ instructions to use these instruments.
2. A battery-operated AC milliammeter. The Data Precision 245 digital multimeter is suitable for this job.
3. Measuring the voltage drop across a resistor by means of a VOM or battery-operated AC voltmeter. The “limit” indication is 0.75 V, so analog meters must have an accurate low-voltage scale. The Simpson 250 and Sanwa SH-63Trd are examples of a passive VOM that is suitable. Nearly all battery operated digital multimeters that have a 2 V AC range are suitable. (See Fig. A)

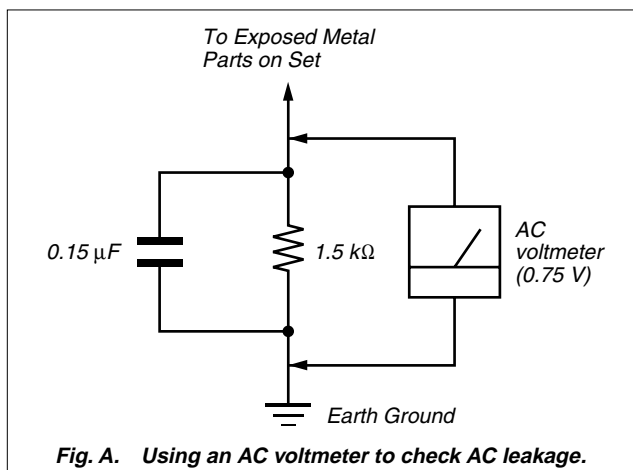

SAFETY-RELATED COMPONENT WARNING!!

COMPONENTS IDENTIFIED BY MARK \triangle OR DOTTED LINE WITH MARK \triangle ON THE SCHEMATIC DIAGRAMS AND IN THE PARTS LIST ARE CRITICAL TO SAFE OPERATION. REPLACE THESE COMPONENTS WITH SONY PARTS WHOSE PART NUMBERS APPEAR AS SHOWN IN THIS MANUAL OR IN SUPPLEMENTS PUBLISHED BY SONY.

**ATTENTION AU COMPOSANT AYANT RAPPORT
À LA SÉCURITÉ!**

LES COMPOSANTS IDENTIFIÉS PAR UNE MARQUE \triangle SUR LES DIAGRAMMES SCHÉMATIQUES ET LA LISTE DES PIÈCES SONT CRITIQUES POUR LA SÉCURITÉ DE FONCTIONNEMENT. NE REMPLACER CES COMPOSANTS QUE PAR DES PIÈCES SONY DONT LES NUMÉROS SONT DONNÉS DANS CE MANUEL OU DANS LES SUPPLÉMENTS PUBLIÉS PAR SONY.

SECTION 1 SERVICING NOTES

NOTES ON HANDLING THE OPTICAL PICK-UP BLOCK OR BASE UNIT

The laser diode in the optical pick-up block may suffer electrostatic break-down because of the potential difference generated by the charged electrostatic load, etc. on clothing and the human body.

During repair, pay attention to electrostatic break-down and also use the procedure in the printed matter which is included in the repair parts.

The flexible board is easily damaged and should be handled with care.

NOTES ON LASER DIODE EMISSION CHECK

The laser beam on this model is concentrated so as to be focused on the disc reflective surface by the objective lens in the optical pick-up block. Therefore, when checking the laser diode emission, observe from more than 30 cm away from the objective lens.

CAUTION

Use of controls or adjustments or performance of procedures other than those specified herein may result in hazardous radiation exposure.

This appliance is classified as a CLASS 1 LASER product. The CLASS 1 LASER PRODUCT MARKING is located on the rear exterior.

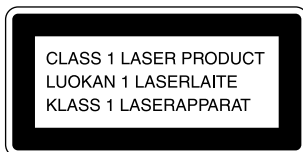

LASER DIODE AND FOCUS SEARCH OPERATION CHECK

Carry out the "S curve check" in "CD section adjustment" and check that the S curve waveforms is output three times.

Notes on chip component replacement

- Never reuse a disconnected chip component.
- Notice that the minus side of a tantalum capacitor may be damaged by heat.

Flexible Circuit Board Repairing

- Keep the temperature of the soldering iron around 270 °C during repairing.
- Do not touch the soldering iron on the same conductor of the circuit board (within 3 times).
- Be careful not to apply force on the conductor when soldering or unsoldering.

HOW TO OPEN THE DISC TABLE WHEN POWER SWITCH TURNS OFF

Insert a tapering driver into the aperture of the unit bottom, and turn it in the direction of the arrow (to OUT direction).

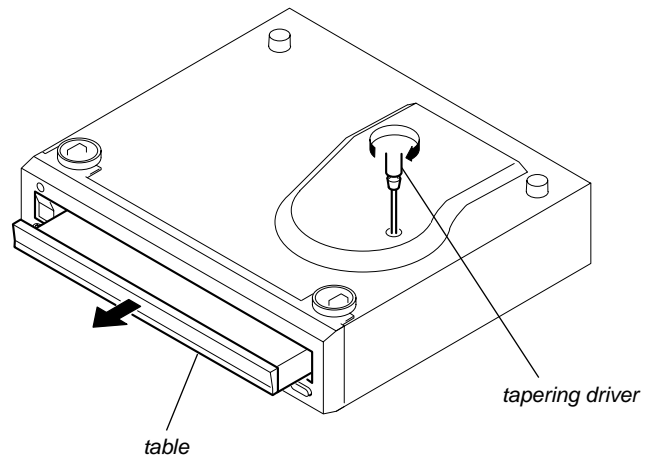

* To close the disc table, turn the tapering driver in the reverse direction (to IN direction).

NOTE FOR MAIN GEAR INSTALLATION

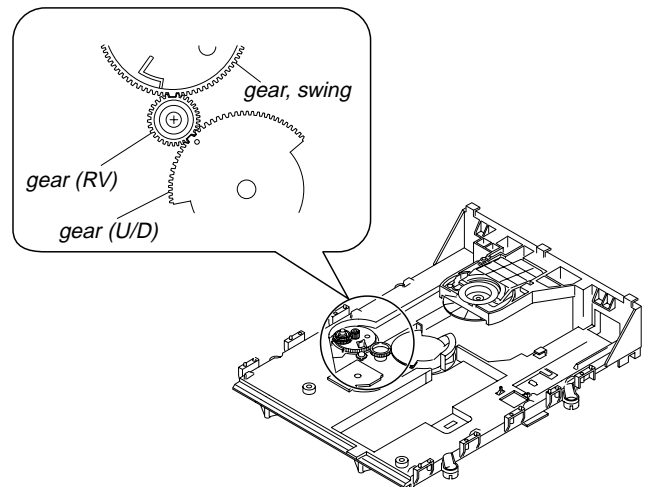

MODEL IDENTIFICATION - BACK PANEL -



Model	Part No.
CDP-CE275: US model	4-233-719-0□
CDP-CE275: Canadian model	4-233-719-1□
CDP-CE275: Australian model	4-233-719-2□
CDP-CE375: US model	4-233-718-0□
CDP-CE375: Canadian model	4-233-718-1□
CDP-CE375: AEP model	4-233-718-2□
CDP-CE375: UK model	4-233-718-3□
CDP-CE375: Australian model	4-233-718-4□
CDP-CE375: E model	4-233-718-5□
CDP-CE375: Singapore model	4-233-718-6□

SECTION 2 GENERAL

• LOCATION OF CONTROLS

– Front panel –

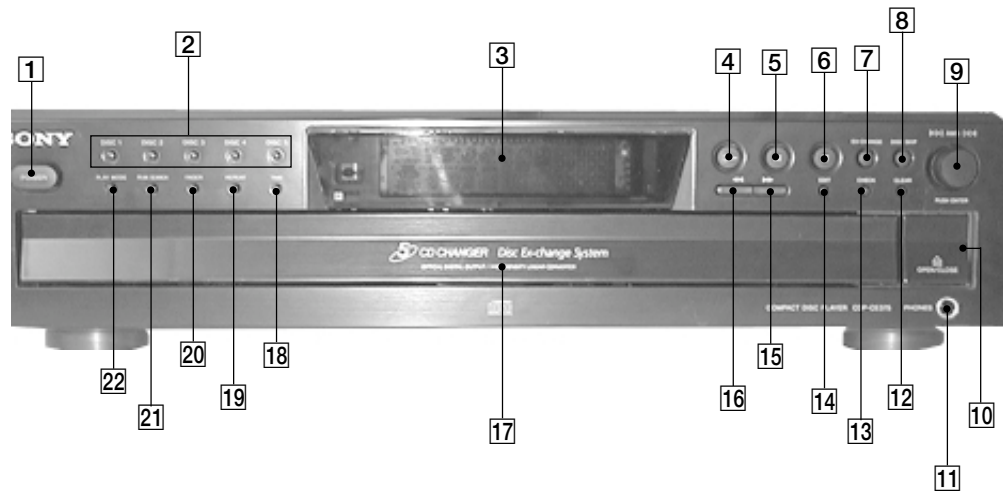

- | | |
|---|------------------------------|
| 1 POWER button | 12 CLEAR button |
| 2 DISC1 – DISC5 button | 13 CHECK button |
| 3 Fluorescent indicator tube display | 14 EDIT button |
| 4 ▷ button | 15 ►► button |
| 5 button | 16 ◀◀ button |
| 6 ■ button | 17 Disc table |
| 7 EX-CHANGE button | 18 TIME button |
| 8 DISC SKIP button | 19 REPEAT button |
| 9 ◀◀ AMS ▷▷ control | 20 FADER button |
| 10 ≡ OPEN/CLOSE button | 21 PEAK SEARCH button |
| 11 PHONES jack | 22 PLAY MODE button |

– Rear panel –



- | |
|--|
| 1 DIGITAL OUT OPTICAL connector |
| 2 ANALOG OUT |

SECTION 3 DISASSEMBLY

• The equipment can be removed using the following procedure.

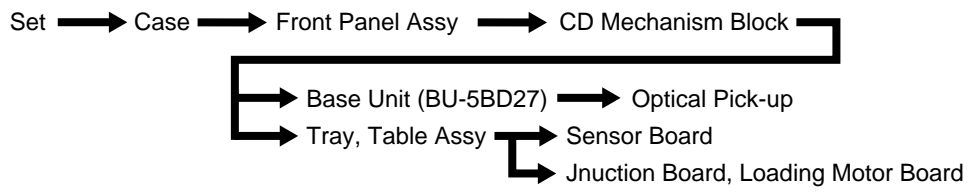

Note: Follow the disassembly procedure in the numerical order given.

3-1. CASE

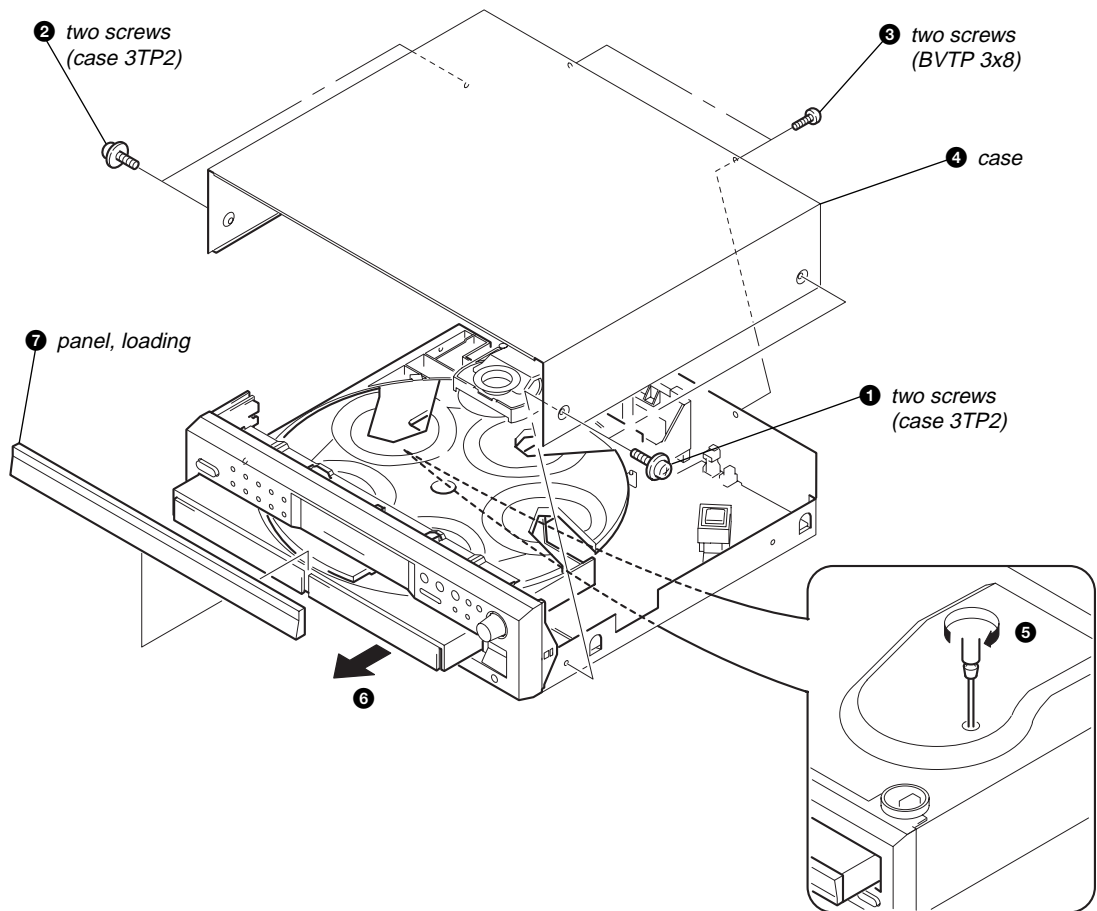

3-2. FRONT PANEL ASSY

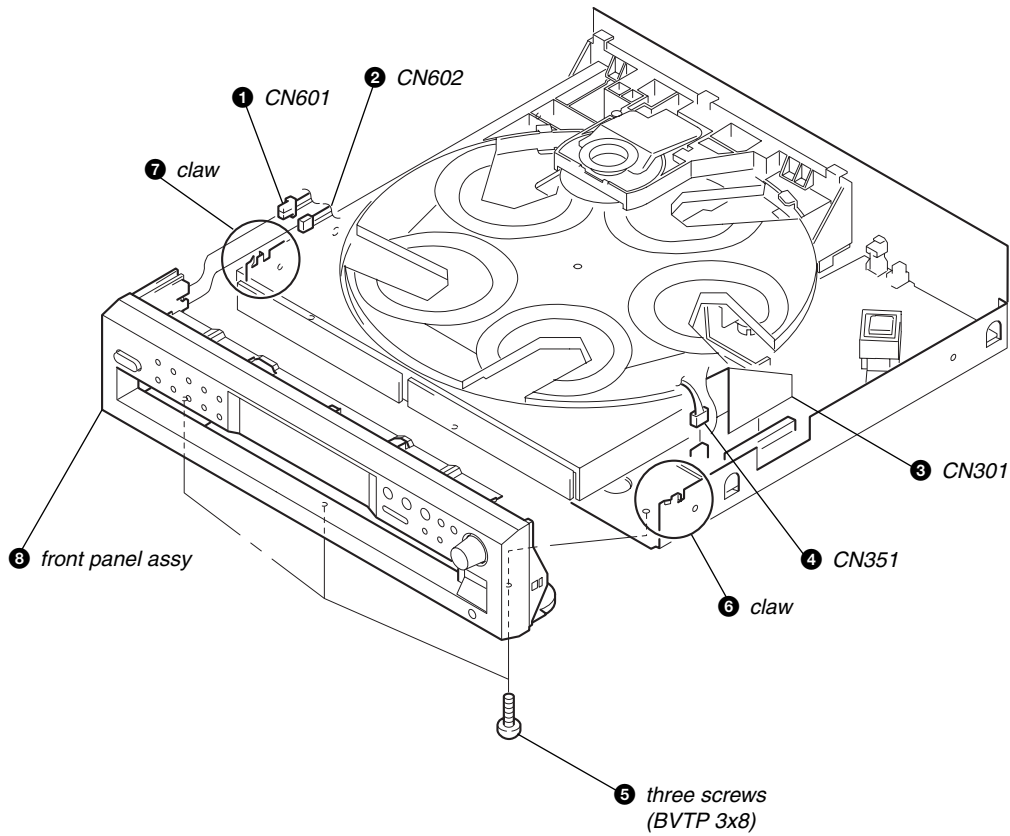

3-3. CD MECHANISM BLOCK (CDM59-5BD27)

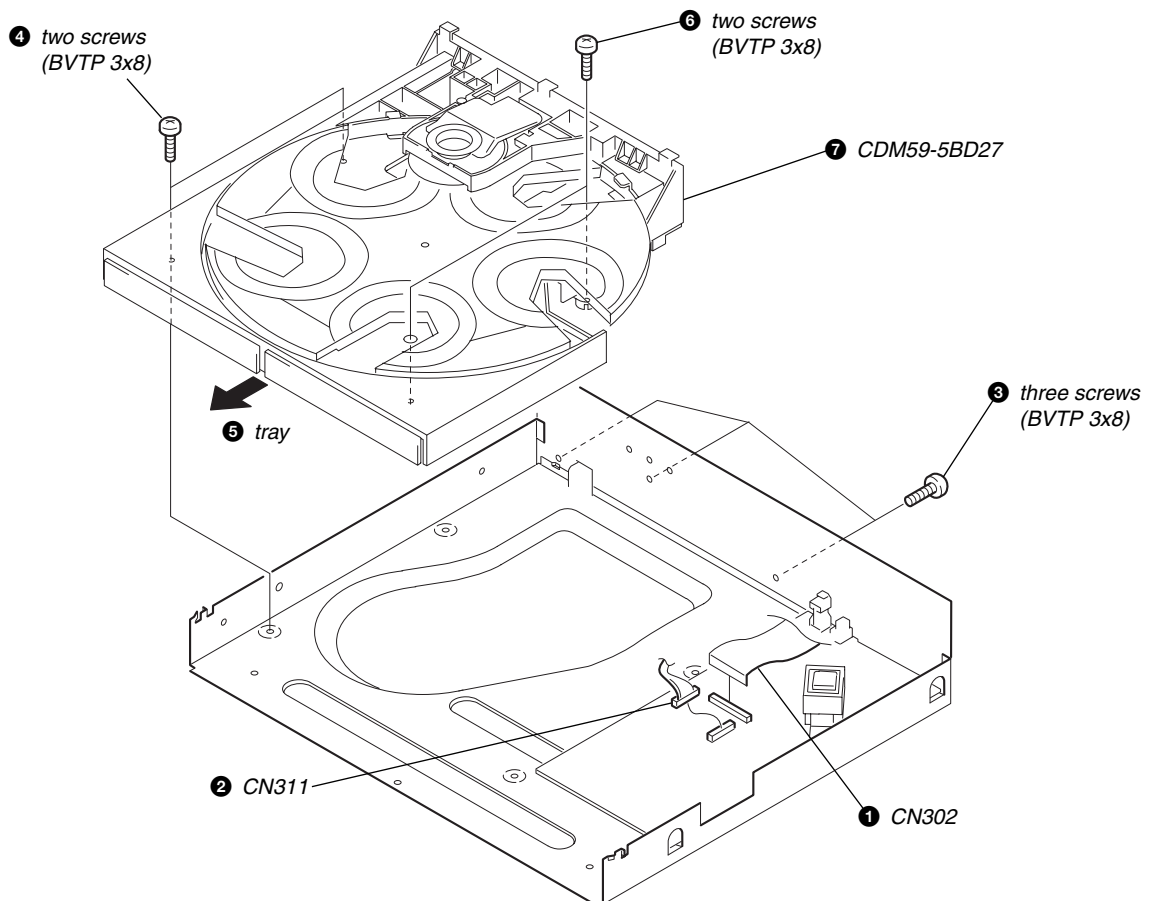

3-4. BASE UNIT (BU-5BD27)

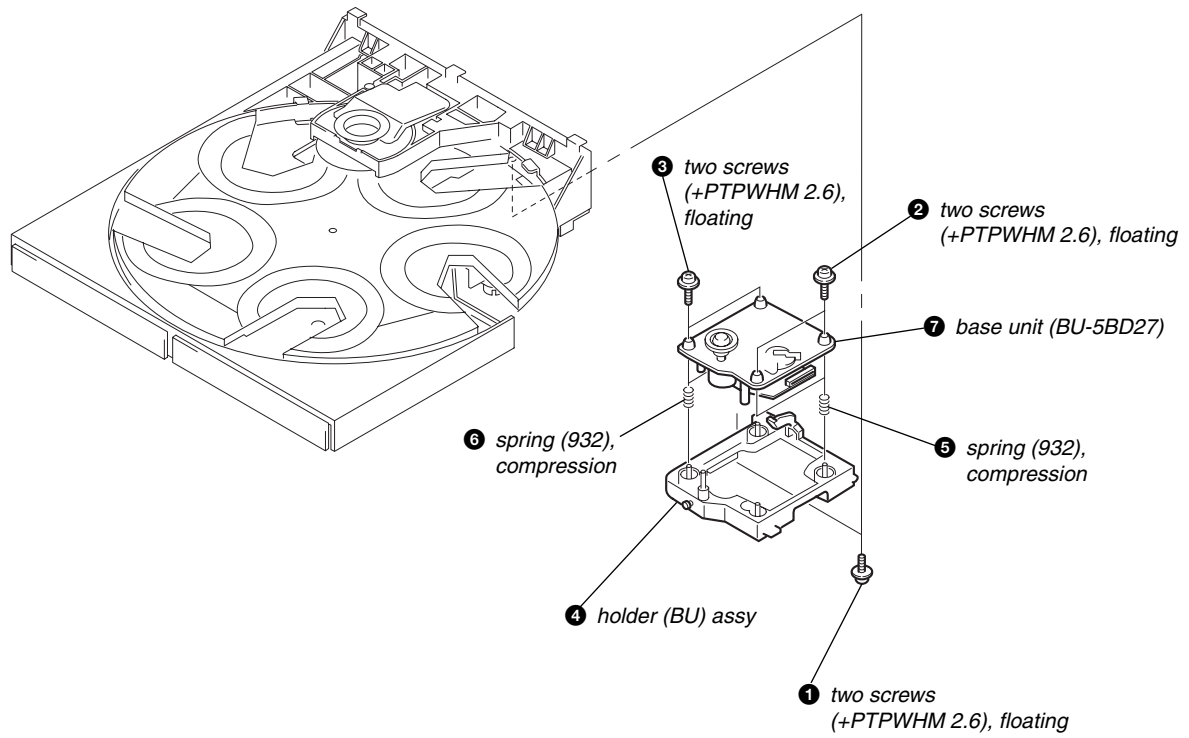

3-5. TRAY, TABLE ASSY

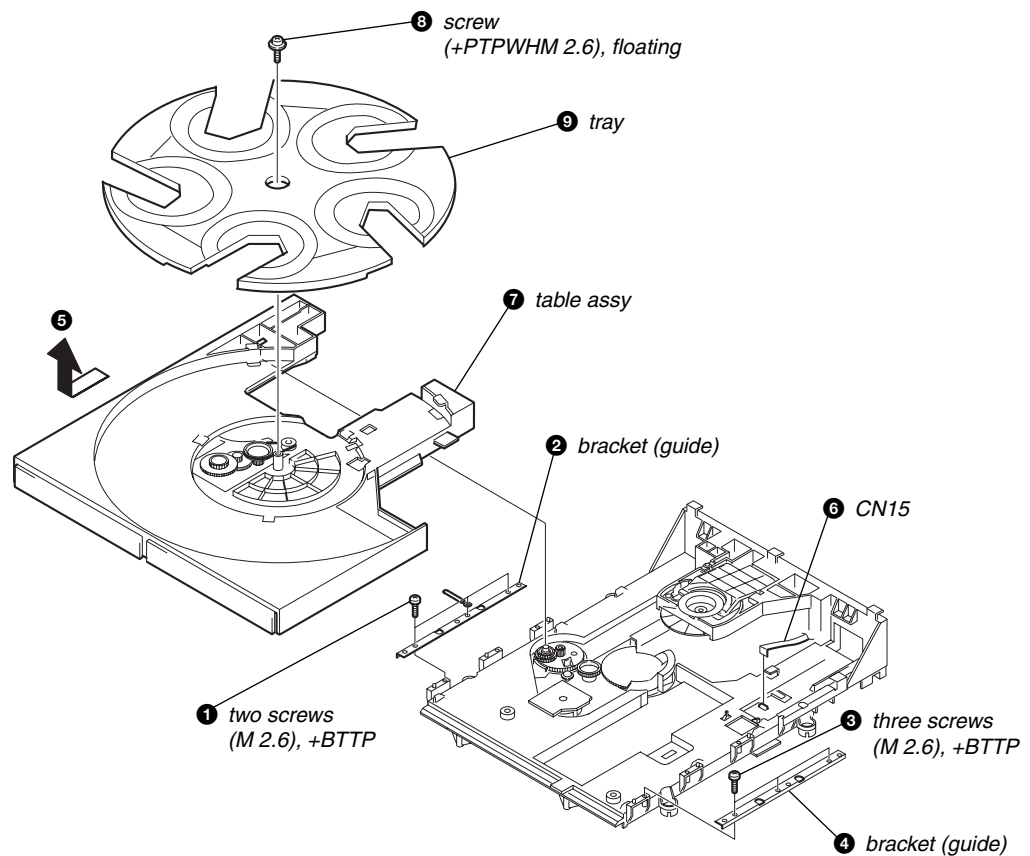

3-6. SENSOR BOARD

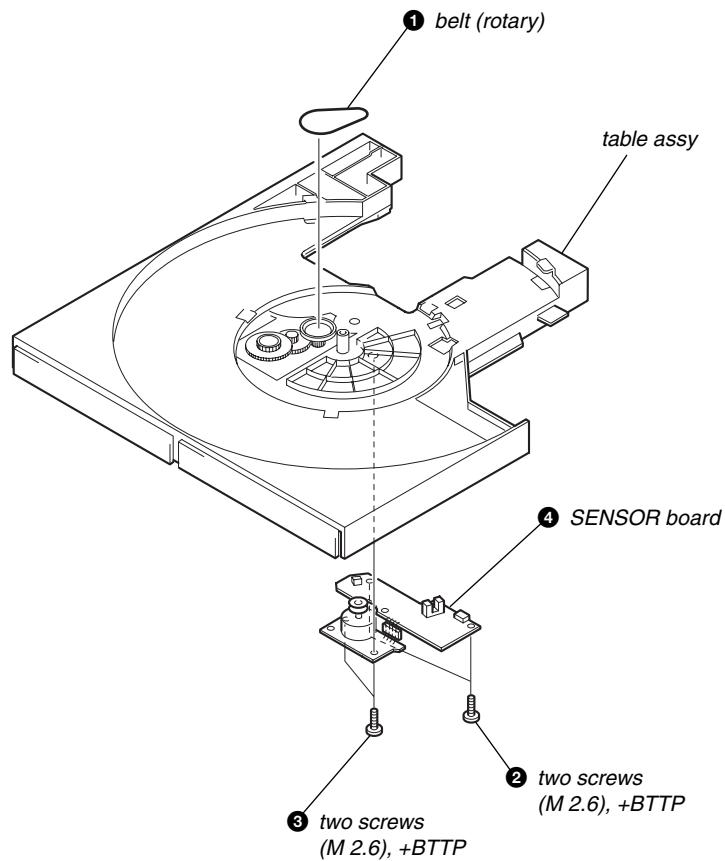

3-7. JUNCTION BOARD, LOADING MOTOR BOARD

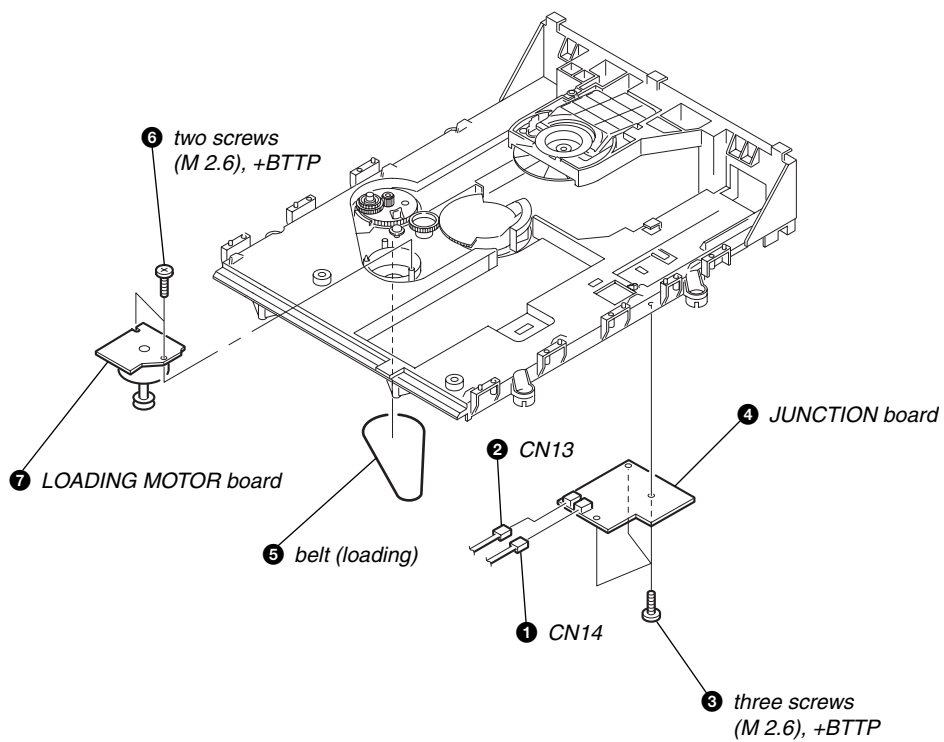

3-8. OPTICAL PICK-UP

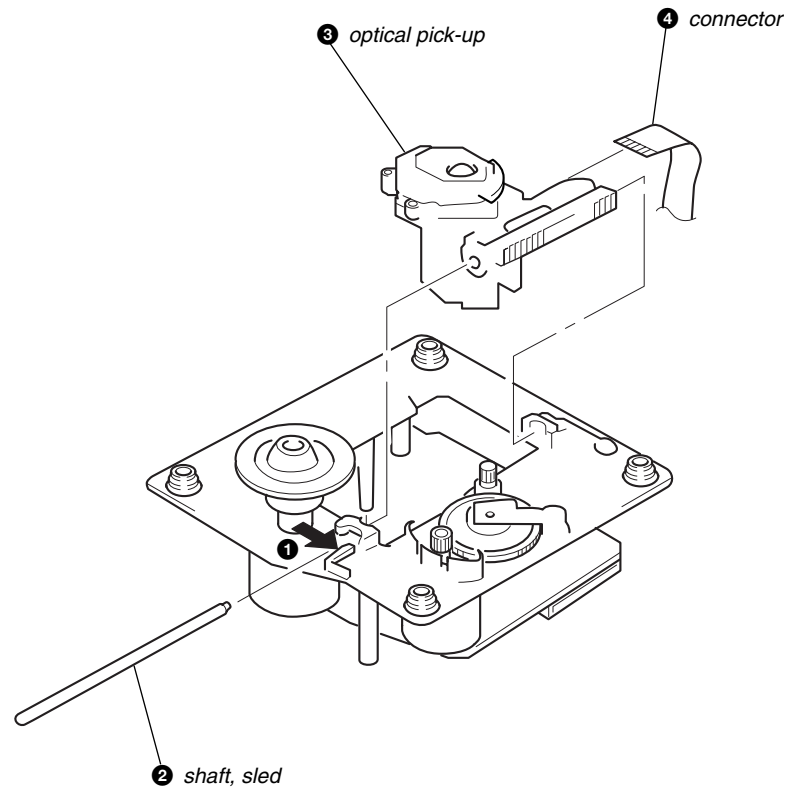

SECTION 4 TEST MODE

ADJ MODE

NOTE: This mode cannot be performed without a general remote commander.

1. Chuck the CD first, and then turn OFF the power.
2. Short-circuit the test point TP1 (ADJ) of the MAIN board and ground with a lead wire.
3. Press the **POWER** button to turn ON the power.
The CD is playback automatically and the ADJ mode is set.
4. To exit the mode, press the **POWER** button to turn OFF the power.

- Prohibits high speed search during accessing
- Ignores even if GFS becomes "L"

ADJ Mode Special Function Table

Button	Function
PLAY MODE	Auto gain display (Focus, Tracking and Sledding)
EDIT	RFCK → GFS → Error rate display

FLUORESCENT INDICATOR TUBE ALL LIT, AND KEY CHECK MODE

1. Short-circuit the test TP2 (AFADJ) of the MAIN board and ground with a lead wire.
2. Press the **POWER** button to turn ON the power.
The whole fluorescent indicator tube lights up.
3. All buttons have individual button numbers.
When a button is pressed, the button number is counted up and displayed.

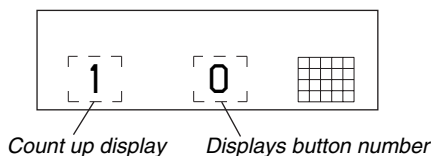

When remote controller signals are received, "RM **" will be displayed.

(* are the numbers corresponding to the remote controller buttons.)

When using the remote controller, switch the **CD1/2/3** switch to CD1.

4. To exit the mode, press the **POWER** button to turn OFF the power.

Connecting Location:

– MAIN BOARD (Component Side) –

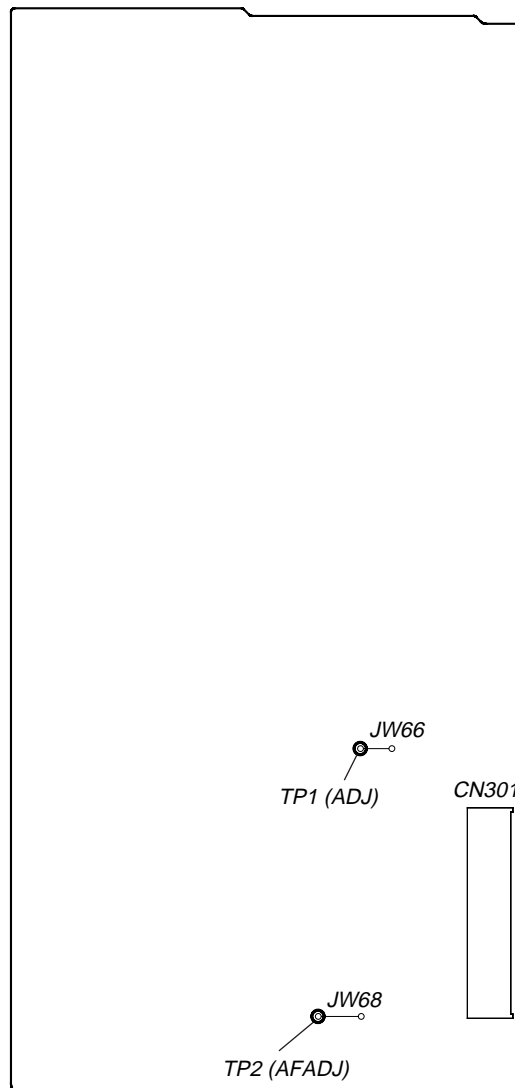

Buttons and Corresponding Button Numbers

Button	Button Number or Display
DISC1	12
DISC2	11
DISC3	10
DISC4	9
DISC5	8
PLAY MODE	20
PEAK SEARCH	19
FADER	18
REPEAT	17
TIME	16
▷ (PLAY)	Partial lighting 1
▬ (PAUSE)	Partial lighting 2
■ (STOP)	All lit
EX-CHANGE	35
DISC SKIP	36
◀◀	24
▶▶	25
EDIT	26
CHECK	27
CLEAR	28
AMS (push)	37
AMS (turn)	When rotated clockwise: The music calendar numerals light up in ascending order. When rotated counterclockwise: The music calendar numerals light up in descending order.

All lit

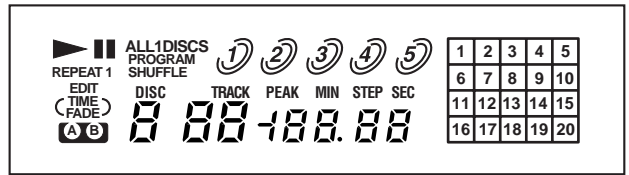

Partial lighting 1

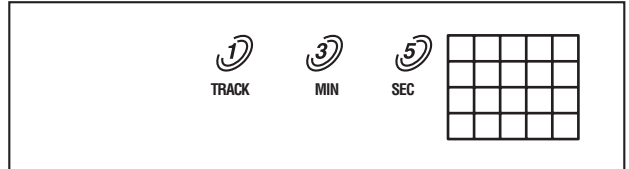

↕ Light alternately



Partial lighting 2



↕ Light alternately



AGING MODE

For the aging mode, three modes of all mode, disc table mode, and loading mode are available.

This set has the Aging mode for operation check of the mechanism deck.

- If a failure occurred

The aging operation stops and a faulty status is displayed on the fluorescent indicator tube.

- If no failure occurs

The aging operation continues repeatedly.

Note: Do not use the test disc when performing aging.

Aging will not be performed properly if discs with tracks shorter than 4 seconds are used.

Procedure:

1. Press the **POWER** button and turn ON the power.

2. Set discs on all trays.

(More than two discs if five are not available)

3. All mode:

Press the **CHECK**, **PLAY MODE** and **■** buttons at the same time.

Disc table mode:

Press the **CHECK**, **PLAY MODE** and **SKIP** buttons at the same time.

Loading mode:

Press the **CHECK**, **PLAY MODE** and **EX-CHANGE** buttons at the same time.

4. Aging starts, and the fluorescent indicator tube will display the following.

5. To exit the mode, press the **POWER** button to turn OFF the power.

Code No.	Status	All mode	Disc table mode	Loading mode	Display in Normal operation	Display in case of failure
0	CLOSE (Tray closed)	○	×	○	A-0	Err 0
1	TOC reading	○	○	○	A-1	Err 1
2	Access to last track	○	×	×	A-2	Err 2
3	Play of last track (3 sec)	○	×	×	Counter display	Err 3
4	EX OPEN (Tray opened while chucking)	○	×	○	A-4	Err 4
5	EX SKIP (Disc tray rotated)	○	×	×	A-5	Err 5
6	EX CLOSE (Tray closed)	○	×	○	A-6	Err 6
7	Access to first track	○	×	×	A-7	Err 7
8	Play of first track (3 sec)	○	×	×	Counter display	Err 8
9	OPEN (tray opened)	○	×	○	A-9	Err 9
A	DISC SKIP (Disc tray rotated, Ond next disc was selected)	○	○	×	A-A	Err A

The discs are selectie in the order of DISC1 → DISC2 → DISC3 → DISC4 → DISC5 → DISC1 → Empty trays are skipped. But the order is random in the disc table mode.

MECHANISM DECK CHECK MODE

For the mechanism deck check mode, two modes of disc table mode and loading mode are available.

In the mechanism deck check mode, the disc table turning time and the loading time in each section are measured and displayed.

Procedure:

Disc table mode:

Press the **POWER** switch while pressing **▶**, **OPEN/CLOSE** and **REPEAT** buttons simultaneously.

Loading mode:

Press the **POWER** switch while pressing **▶**, **OPEN/CLOSE** and **TIME** buttons simultaneously.

Display contents

Mode	Check command	Display
Disc table mode (Table turning time measurement)	0: Right one turn	r 12.5
	1: Left one Turn	L 10.2
	2: Measurement end	r 12.5
	3: Undefined	
Table mode (Loading time measurement)	4: Star position	Sta --.
	5: Open → Close	CLo 10.2
	6: Close → BU up	UP 0.7
	7: BU up → EX open	EoP 6.2
	8: EX open → EX close	ECL 10.3
	9: EX close → BU down	don 1.2
	A: BU down → Open	oPn 9.3
	FF: Measurement end	CLo 10.2

SECTION 5 ELECTRICAL ADJUSTMENTS

Note:

1. CD Block is basically designed to operate without adjustment. Therefore, check each item in order given.
2. Use PATD-012 disc (4-225-203-01) unless otherwise indicated.
3. Use an oscilloscope with more than 10MΩ impedance.
4. Clean the object lens by an applicator with neutral detergent when the signal level is low than specified value with the following checks.

S Curve Check

Connection:

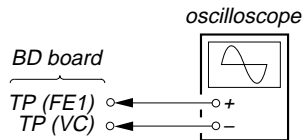

Procedure:

1. Set the test disc (PATD-012). Disc chucking operation is complete, then press the **POWER** button to turn the power off.
2. Connect an oscilloscope to test point TP (FE1) and TP (VC) on the BD board.
3. Connect between test point TP (ADJ) on the MAIN board and GND by lead wire.
4. Press the **POWER** button to turn the power on and enter the ADJ mode.
Then playback the number two track automatically, press the **STOP** button to stop the playback.
5. Press the **CHECK** button actuate the focus search. (actuate the focus search when disc table is moving in and out)
6. Check the oscilloscope waveform (S-curve) is symmetrical between A and B. And confirm peak to peak level within 2 ± 1 Vp-p.

S-curve waveform

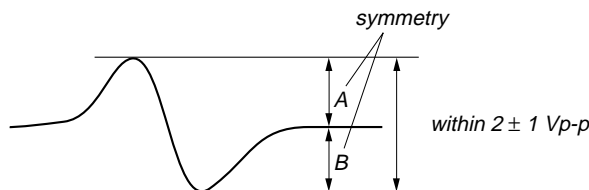

- Note:**
- Try to measure several times to make sure than the ratio of A : B or B : A is more than 10 : 7.
 - Take sweep time as long as possible and light up the brightness to obtain best waveform.

Checking Location: BD board

RFDC Level Check

Connection:

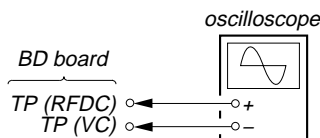

Procedure:

1. Set the test disc (PATD-012). Disc chucking operation is complete, then press the **POWER** button to turn the power off.
2. Connect an oscilloscope to test point TP (RFDC) and TP (VC) on the BD board.
3. Connect between test point TP (ADJ) on the MAIN board and GND by lead wire.
4. Press the **POWER** button to turn the power on and enter the ADJ mode, then playback the number two track automatically.
5. Confirm that oscilloscope waveform is clear and check the level of between RFDC top and VC is correct or not.

Note: A clear RFDC signal waveform means that the shape “∩” can be clearly distinguished at the center of the waveform.

RFDC signal waveform

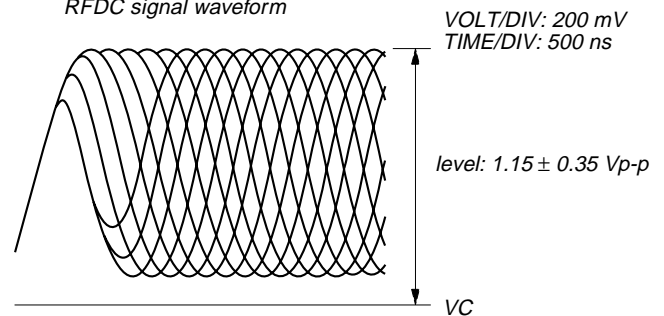

Checking Location: BD board

RFAC Level Check

Connection:

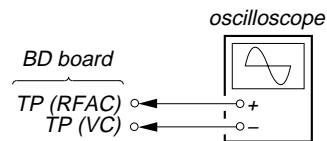

Procedure:

1. Set the test disc (PATD-012). Disc chucking operation is complete, then press the **POWER** button to turn the power off.
2. Connect an oscilloscope to test point TP (RFAC) and TP (VC) on the BD board.
3. Connect between test point TP (ADJ) on the MAIN board and GND by lead wire.
4. Press the **POWER** button to turn the power on and enter the ADJ mode, then playback the number two track automatically.
5. Confirm that oscilloscope waveform is clear and check RFAC signal level is correct or not.

Note: A clear RFAC signal waveform means that the shape “∩” can be clearly distinguished at the center of the waveform.

RFAC signal waveform

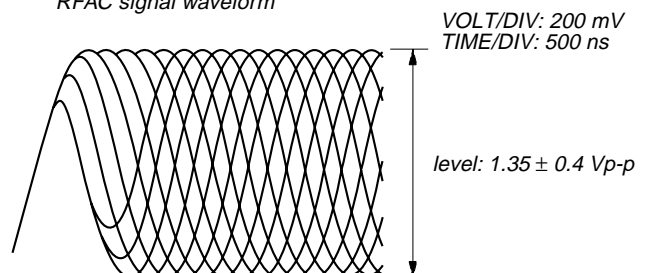

Checking Location: BD board

E-F Balance Check

Connection:

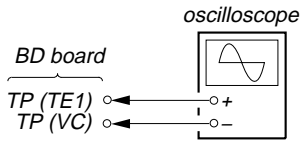

Procedure:

1. Set the test disc (PATD-012). Disc chucking operation is complete, then press the **[POWER]** button to turn the power off.
2. Connect an oscilloscope to test point TP (TE1) and TP (VC) on the BD board.
3. Connect between test point TP (ADJ) on the MAIN board and GND by lead wire.
4. Press the **[POWER]** button to turn the power on and enter the ADJ mode, then playback the number two track automatically.
5. Press the **[TIME]** button. (The tracking servo and the sledding servo are turned OFF)
6. Check the level B of the oscilliscope waveform and the A (DC voltage) of the center of the Traverse waveform.
 Confirm the following :
 $A/B \times 100 = \text{less than } \pm 22\%$

Traverse Waveform

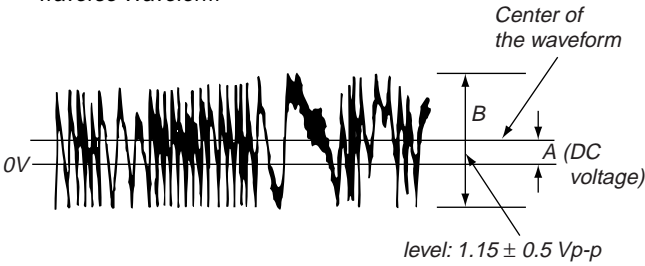

7. Press the **[TIME]** button. (The tracking servo and sledding servo are turned ON)
 Confirm the C (DC voltage) is almost equal to the A (DC voltage) is step 6.

Traverse Waveform

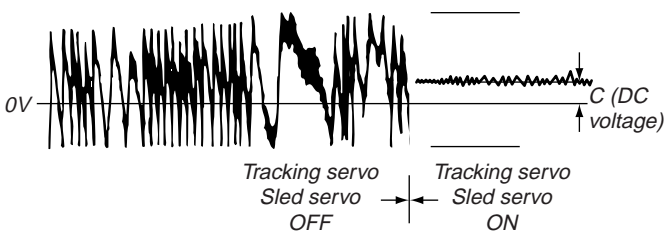

Checking Location: BD board

Checking Location:

- BD BOARD (Conductor Side) -

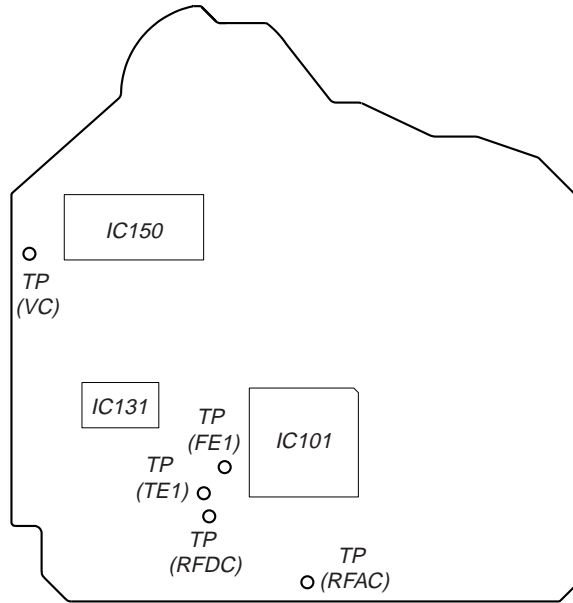

SECTION 6 DIAGRAMS

6-1. NOTE FOR PRINTED WIRING BOARDS AND SCHEMATIC DIAGRAMS

Note on Printed Wiring Board:

- — : parts extracted from the component side.
- : parts extracted from the conductor side.
- : Pattern from the side which enables seeing. (The other layers' patterns are not indicated.)

Caution:

Pattern face side: Parts on the pattern face side seen from the pattern face are indicated.
(Conductor Side)
Parts face side: Parts on the parts face side seen from the parts face are indicated.
(Component Side)

- Indication of transistor

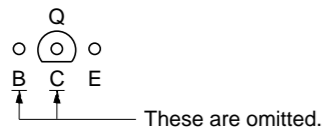
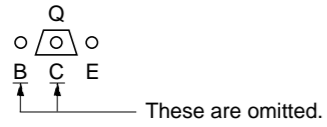

Note on Schematic Diagram:

- All capacitors are in μF unless otherwise noted. pF: $\mu\mu\text{F}$ 50 WV or less are not indicated except for electrolytics and tantalums.
- All resistors are in Ω and $1/4\text{W}$ or less unless otherwise specified.
- Δ : internal component.
- \square : panel designation.

Note:

The components identified by mark Δ or dotted line with mark Δ are critical for safety. Replace only with part number specified.

Note:

Les composants identifiés par une marque Δ sont critiques pour la sécurité. Ne les remplacer que par une pièce portant le numéro spécifié.

- Voltages and waveforms are dc with respect to ground under no-signal conditions.
no mark : CD PLAY
- Voltages are taken with a VOM (Input impedance 10 M Ω). Voltage variations may be noted due to normal production tolerances.
- Waveforms are taken with a oscilloscope. Voltage variations may be noted due to normal production tolerances.
- Circled numbers refer to waveforms.
- Signal path.
 - ◀ : CD PLAY
 - ▶ : DIGITAL OUT
- — : B+ Line
- - - - : B- Line

• Circuit Boards Location

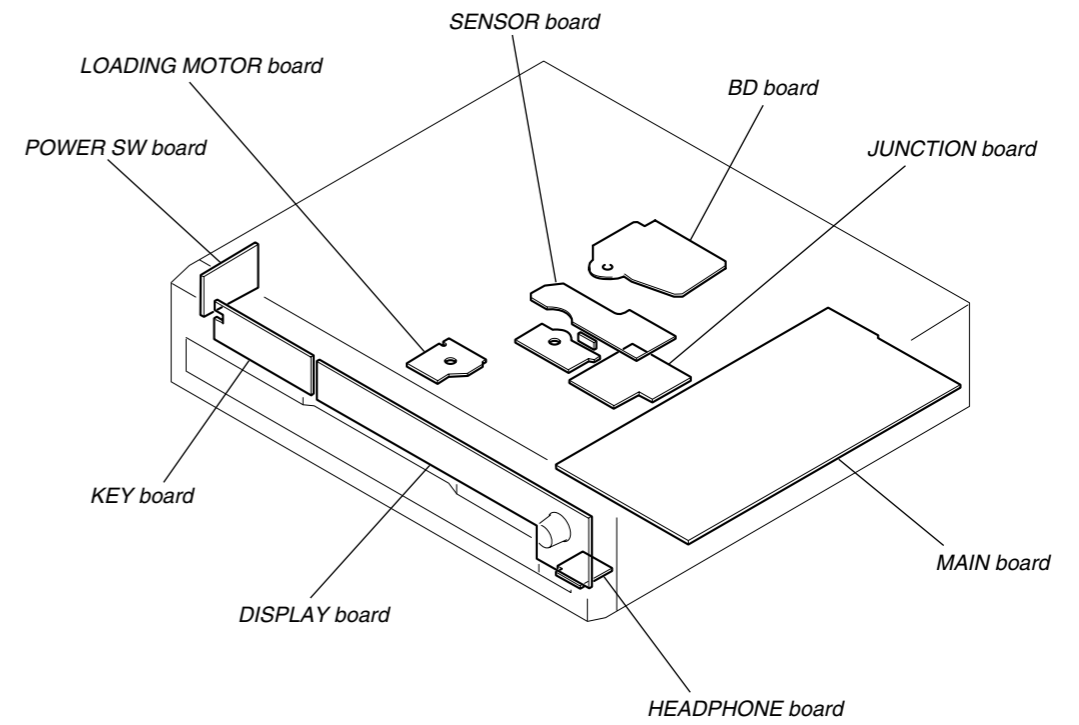

6-2. PRINTED WIRING BOARD – BD Board – • See page 15 for Circuit Boards Location.

【 BD BOARD 】 (COMPONENT SIDE)

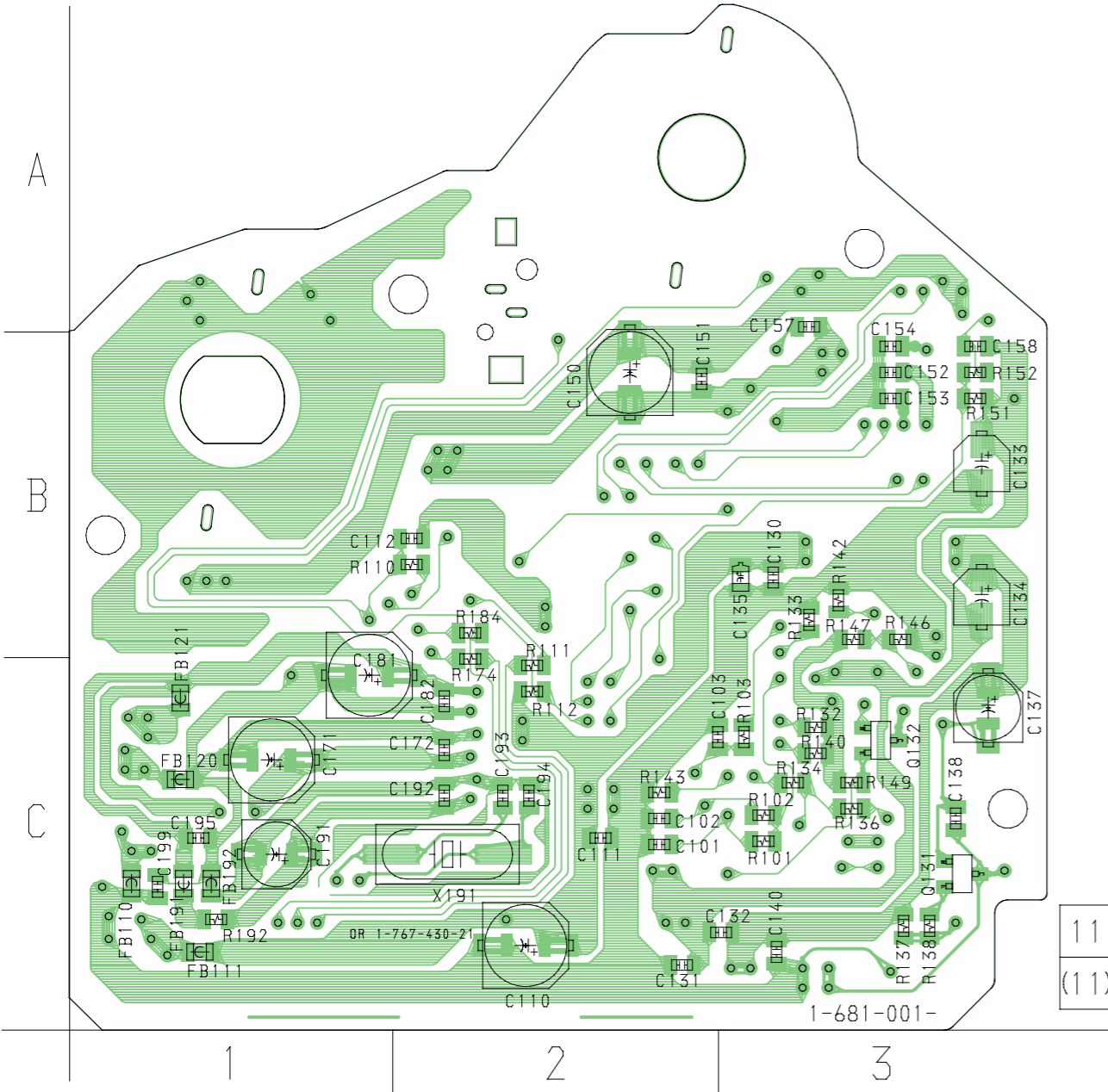

• Semiconductor Location

Ref. No.	Location
Q131	C-3
Q132	C-3

【 BD BOARD 】 (CONDUCTOR SIDE)

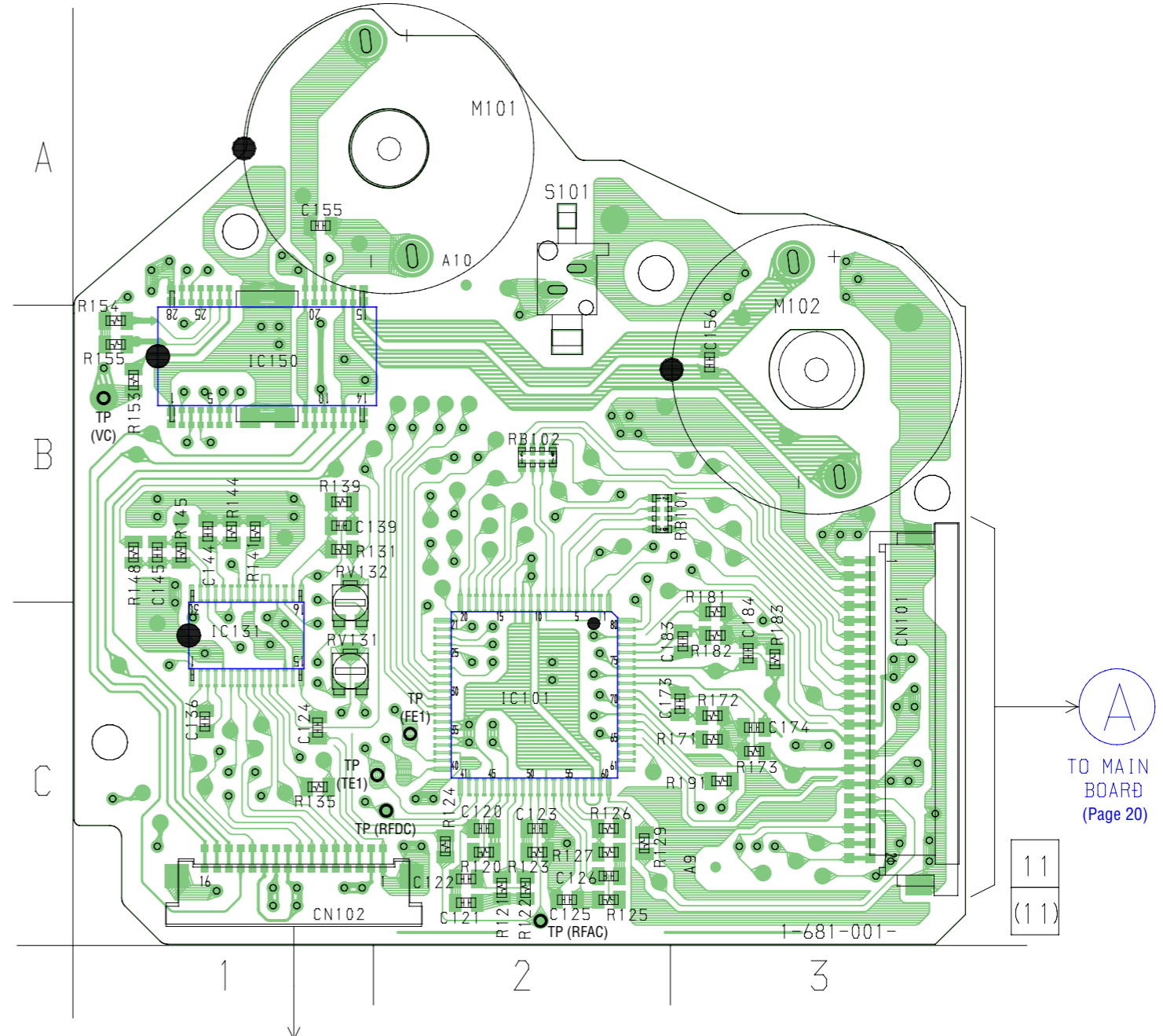

• Semiconductor Location

Ref. No.	Location
IC101	C-2
IC131	C-1
IC150	B-1

6-4. PRINTED WIRING BOARDS – JUNCTION/SENSOR/LOADING MOTOR Boards – • See page 15 for Circuit Boards Location.

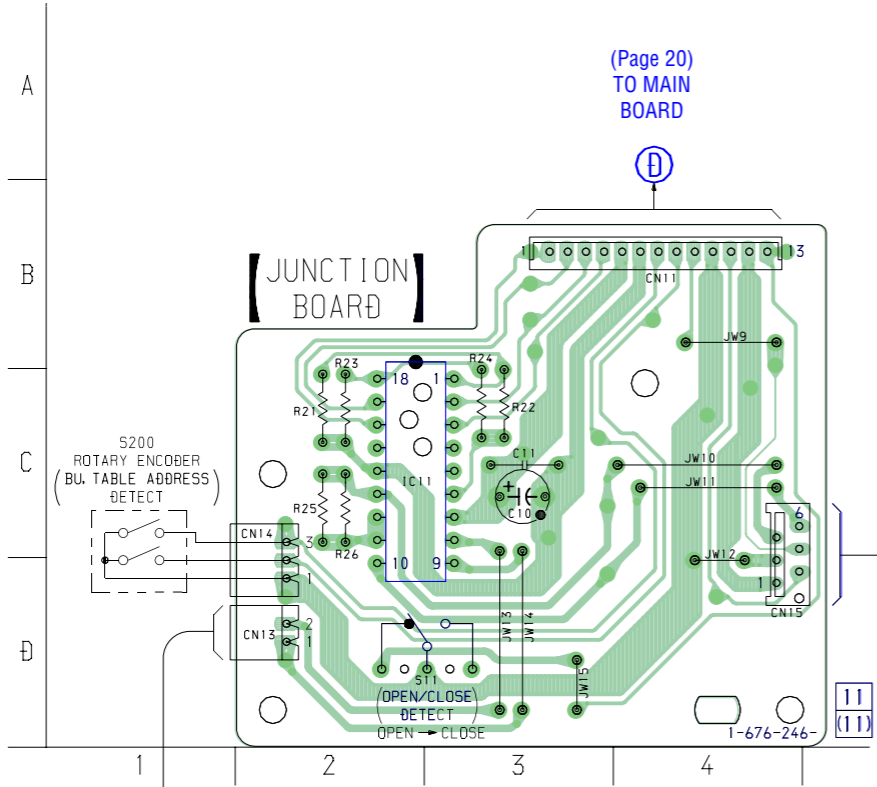

• Semiconductor Location

Ref. No.	Location
IC11	C-2

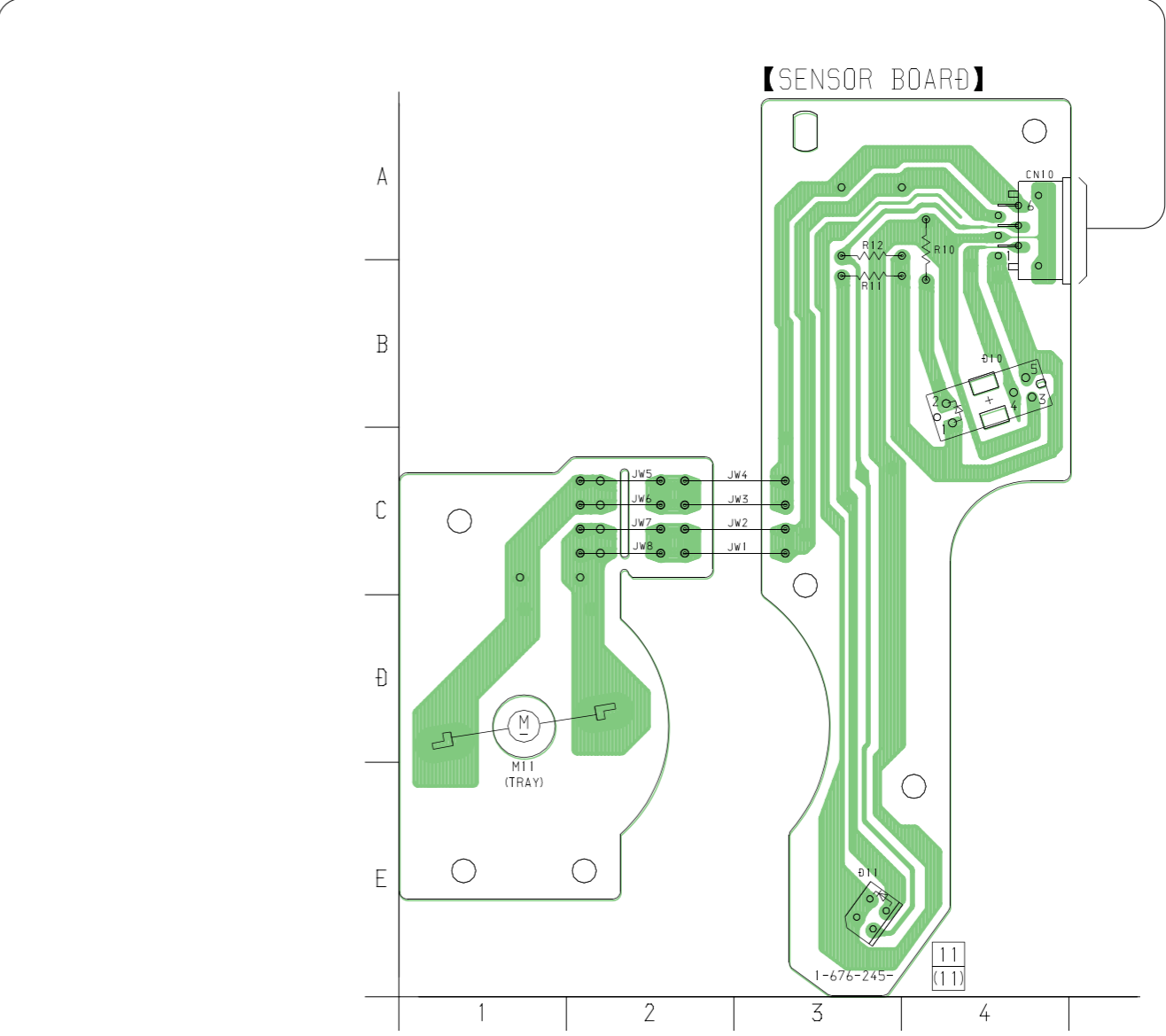
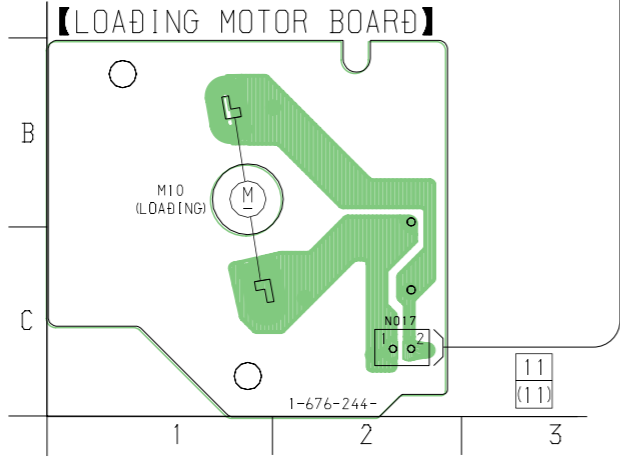

• Semiconductor Location

Ref. No.	Location
D10	B-4
D11	E-3

6-5. SCHEMATIC DIAGRAM – JUNCTION/SENSOR/LOADING MOTOR Boards – • See page 25 for IC Block Diagram.

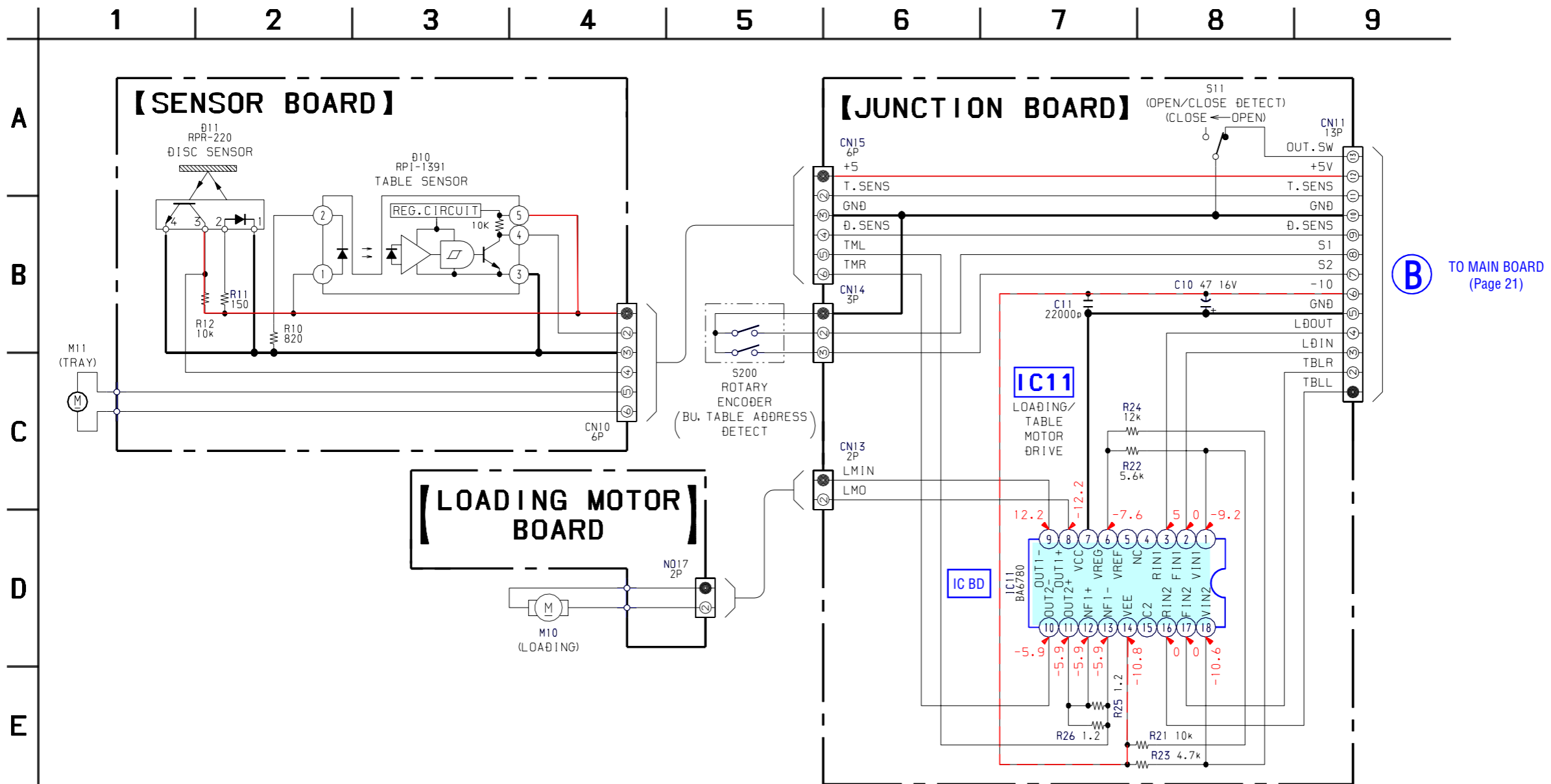

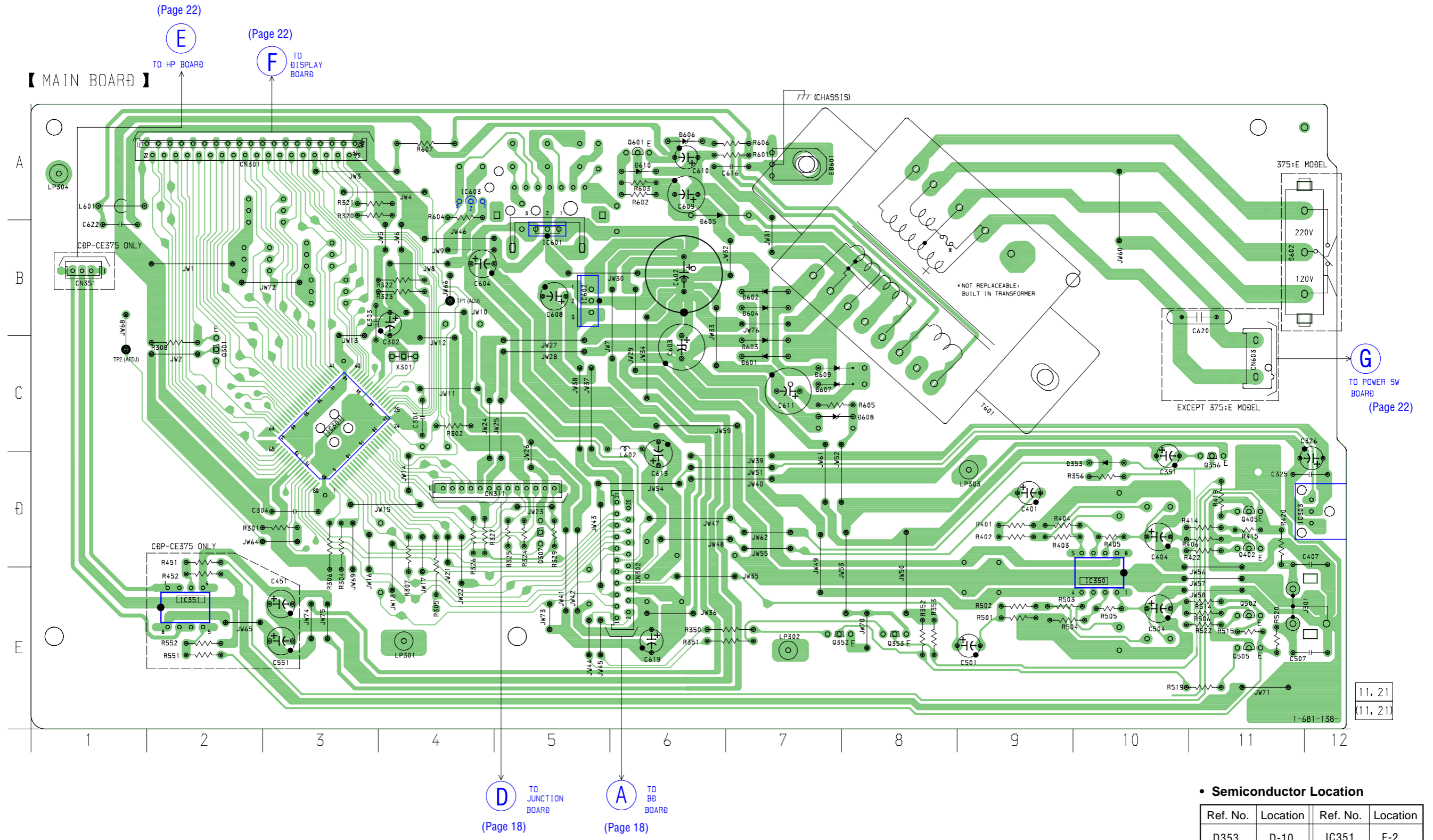

• Semiconductor Location

Ref. No.	Location	Ref. No.	Location
D353	D-10	IC351	E-2
D601	C-7	IC601	A-5
D602	B-7	IC602	B-5
D603	C-7	IC603	A-4
D604	B-7		
D605	B-6	Q301	C-2
D606	A-6	Q307	D-5
D607	C-7	Q352	E-7
D608	C-8	Q353	E-8
D609	C-7	Q356	D-11
D610	A-6	Q402	D-11
		Q405	D-11
IC301	C-3	Q502	E-11
IC303	D-11	Q505	E-11
IC350	E-10	Q601	A-6

6-7. SCHEMATIC DIAGRAM – MAIN Board – • See page 24 for Waveform.

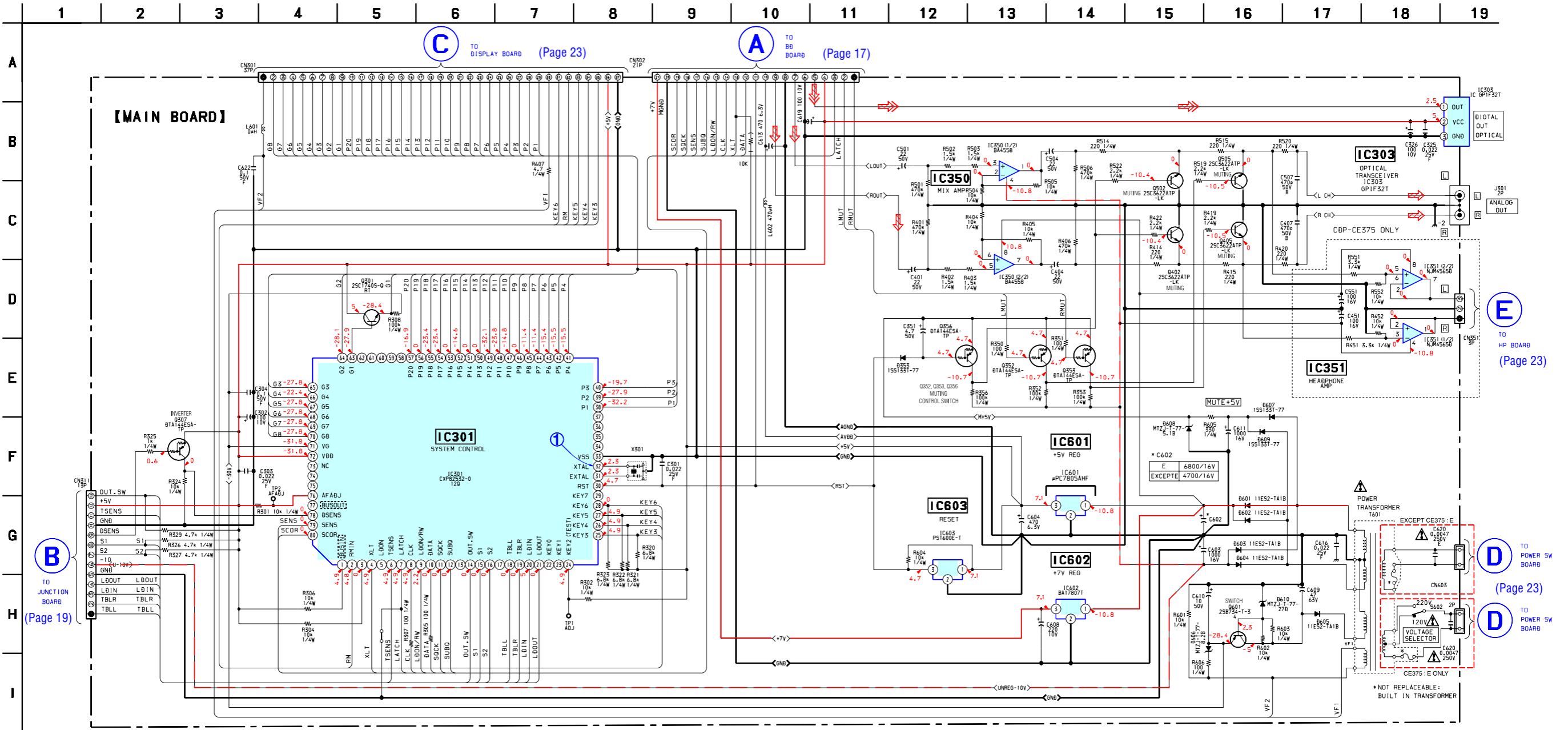

The components identified by mark Δ or dotted line with mark Δ are critical for safety. Replace only with part number specified.

Les composants identifiés par une marque Δ sont critiques pour la sécurité. Ne les remplacer que par une pièce portant le numéro spécifié.

6-8. PRINTED WIRING BOARDS – PANEL Section – • See page 15 for Circuit Boards Location.

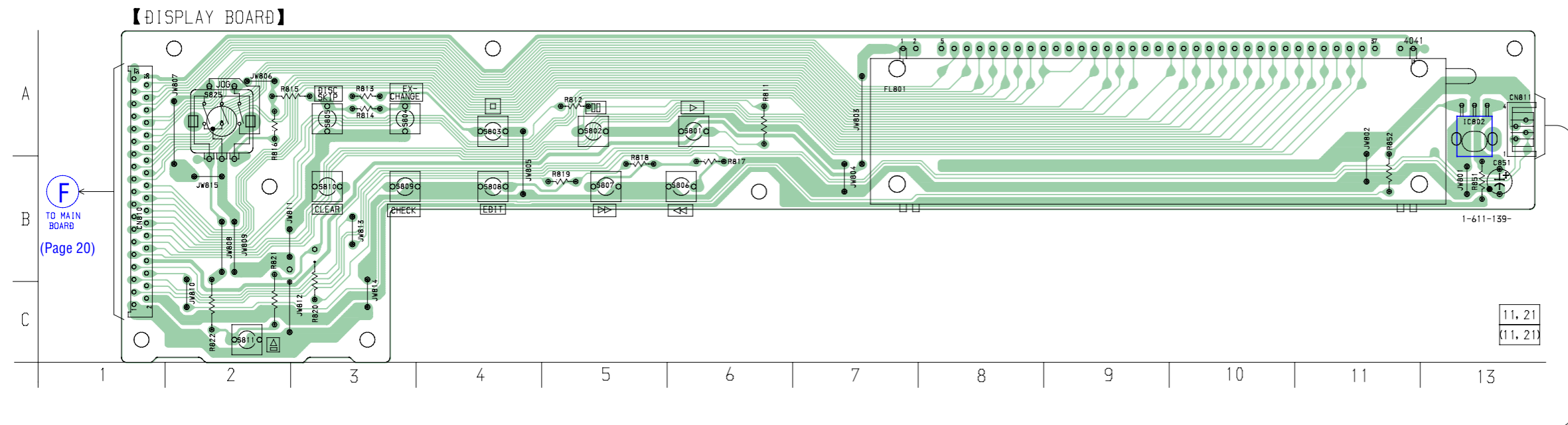

• Semiconductor Location

Ref. No.	Location
IC802	A-13

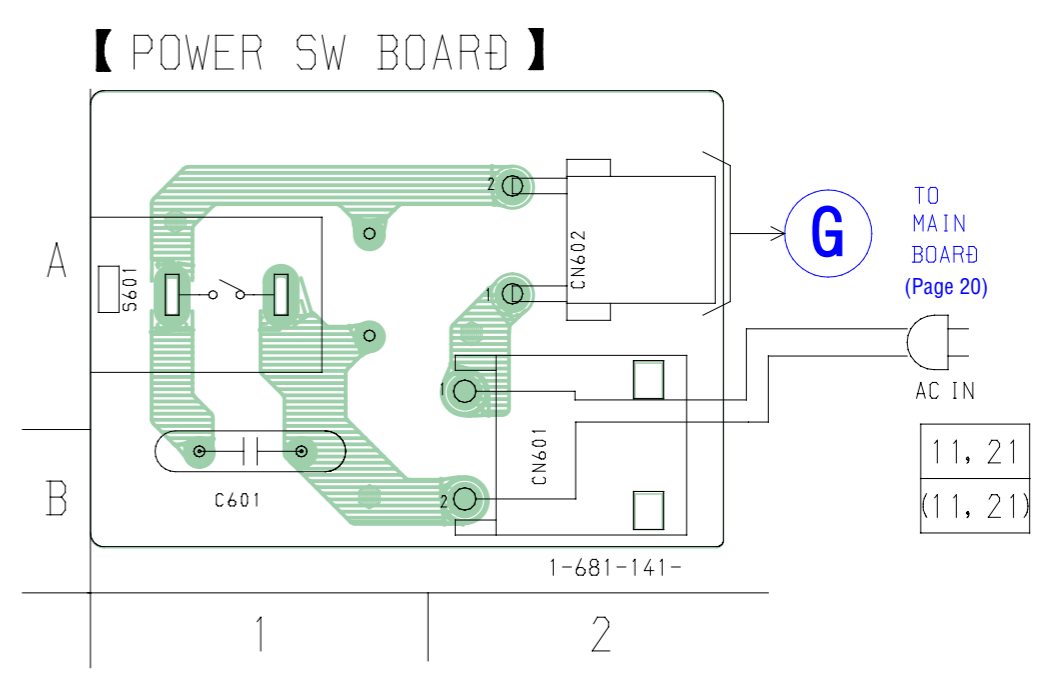
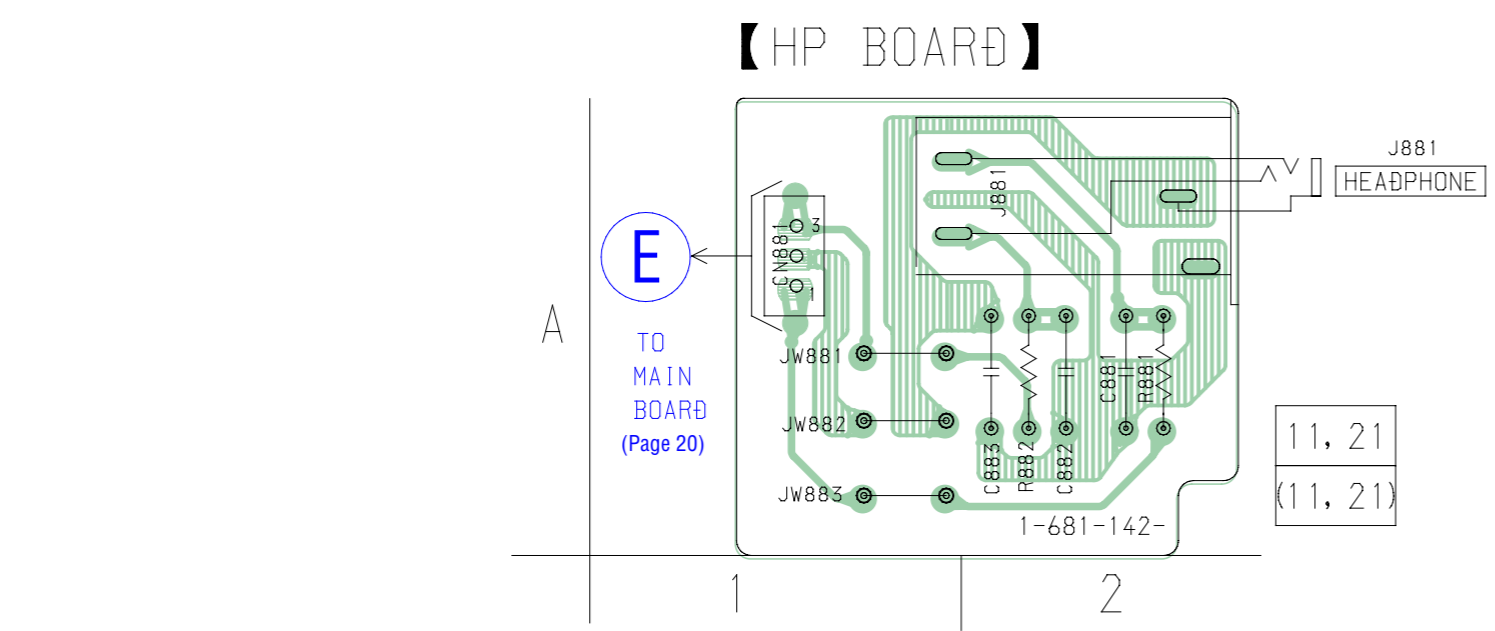
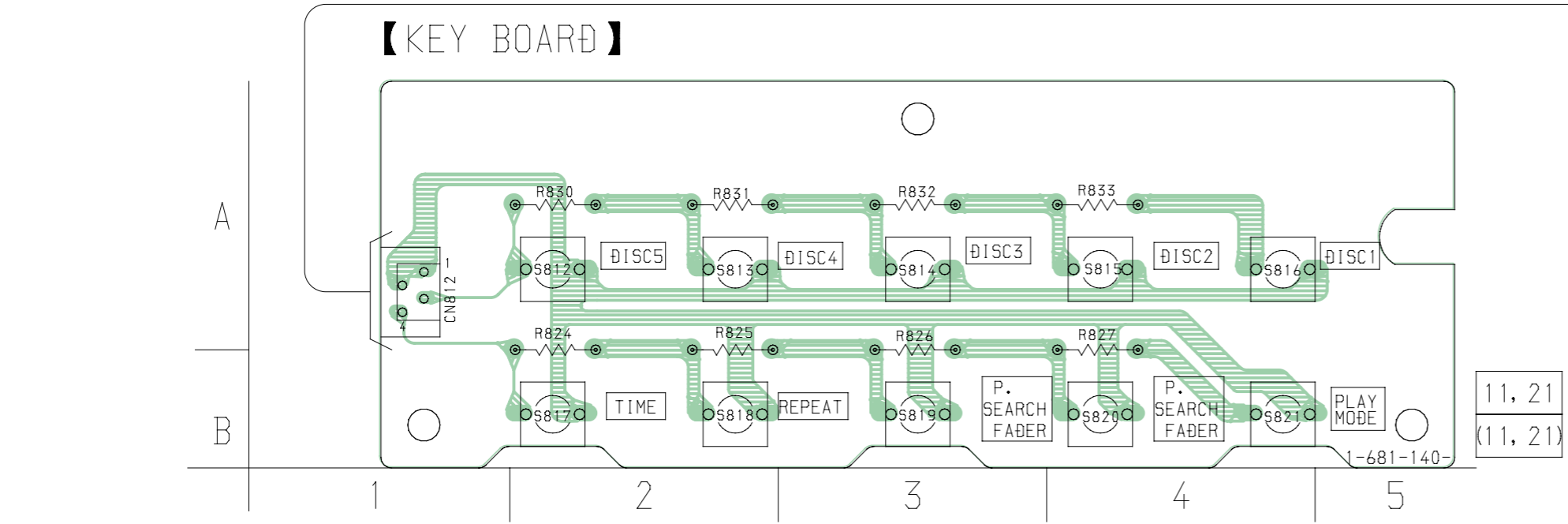

6-9. SCHEMATIC DIAGRAM – PANEL Section –

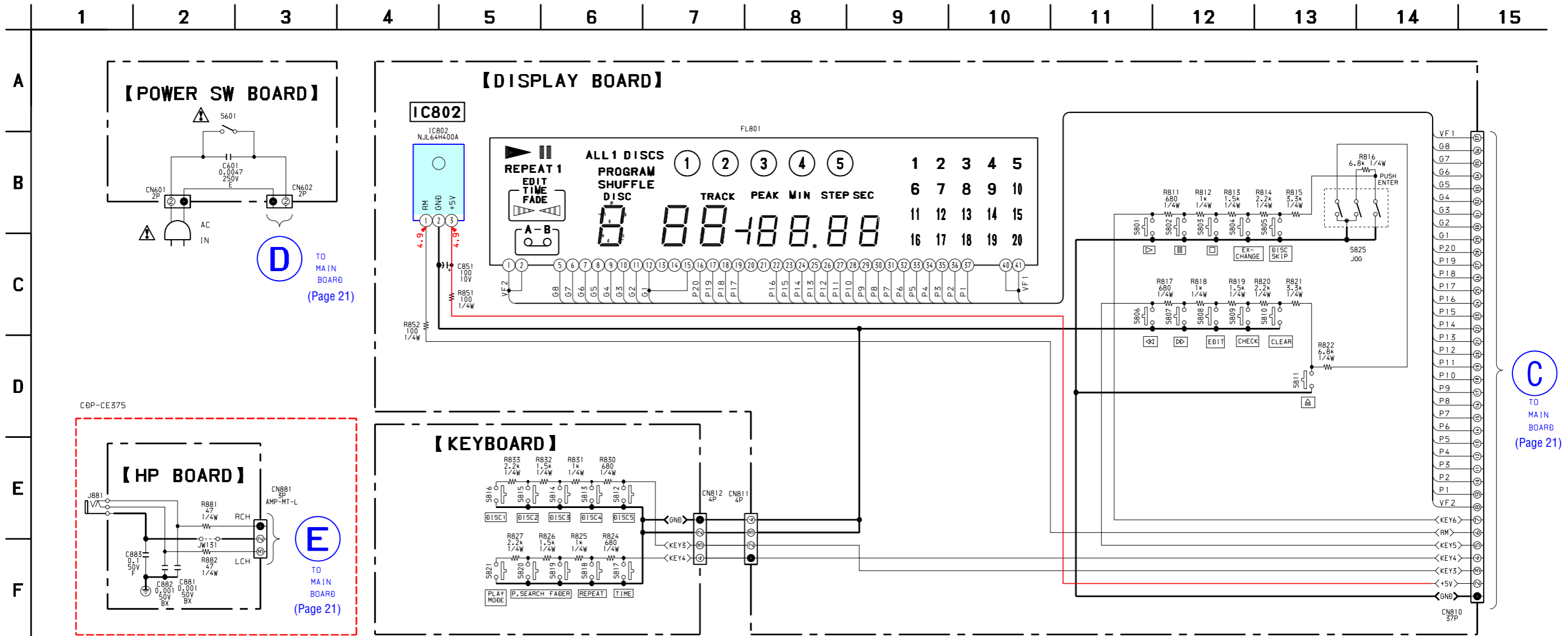

The components identified by mark \triangle or dotted line with mark \triangle are critical for safety. Replace only with part number specified.

Les composants identifiés par une marque \triangle sont critiques pour la sécurité. Ne les remplacer que par une pièce portant le numéro spécifié.

• Waveforms
– BD Board –

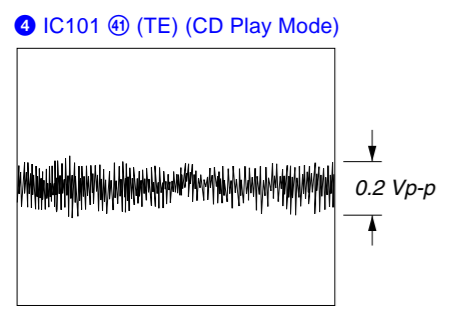
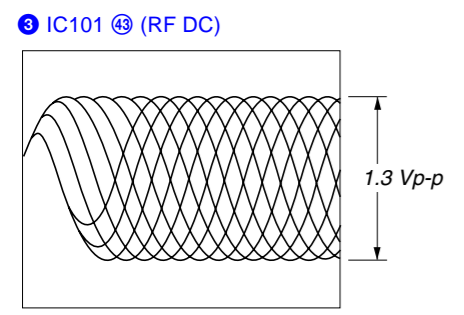
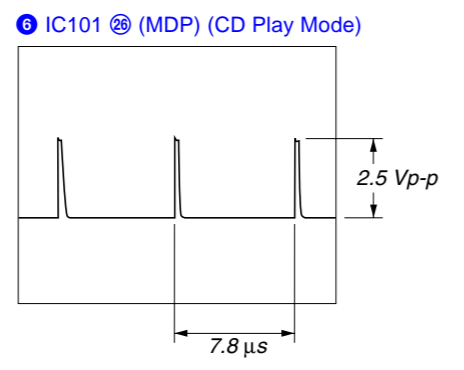
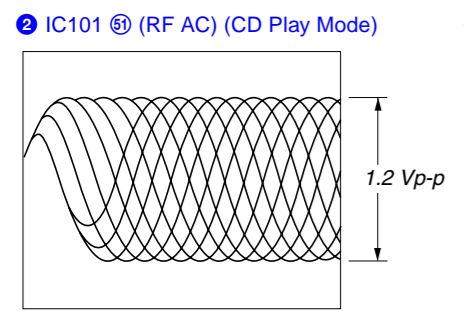
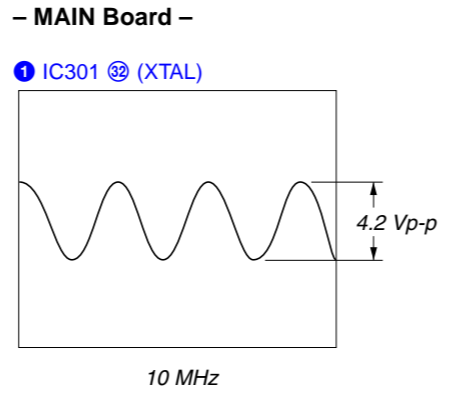
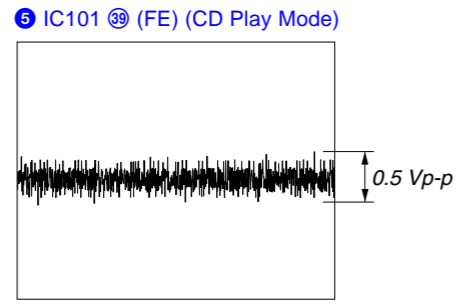
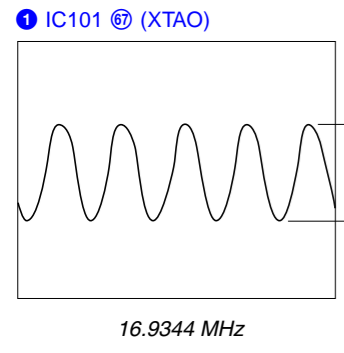

• IC Block Diagrams
– BD BOARD –

IC101 CXD2587Q

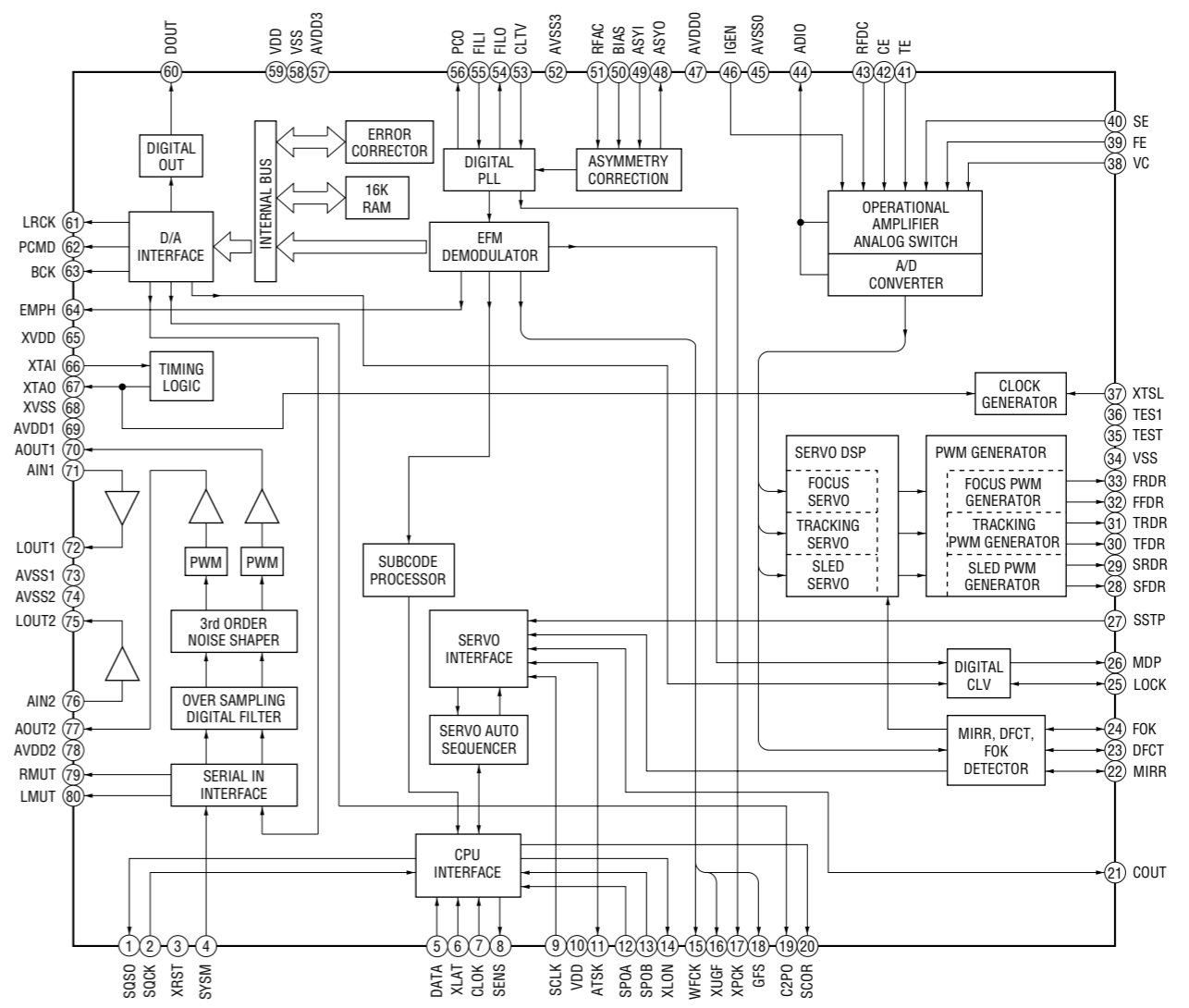

- BD Board -

IC131 CXA2581N

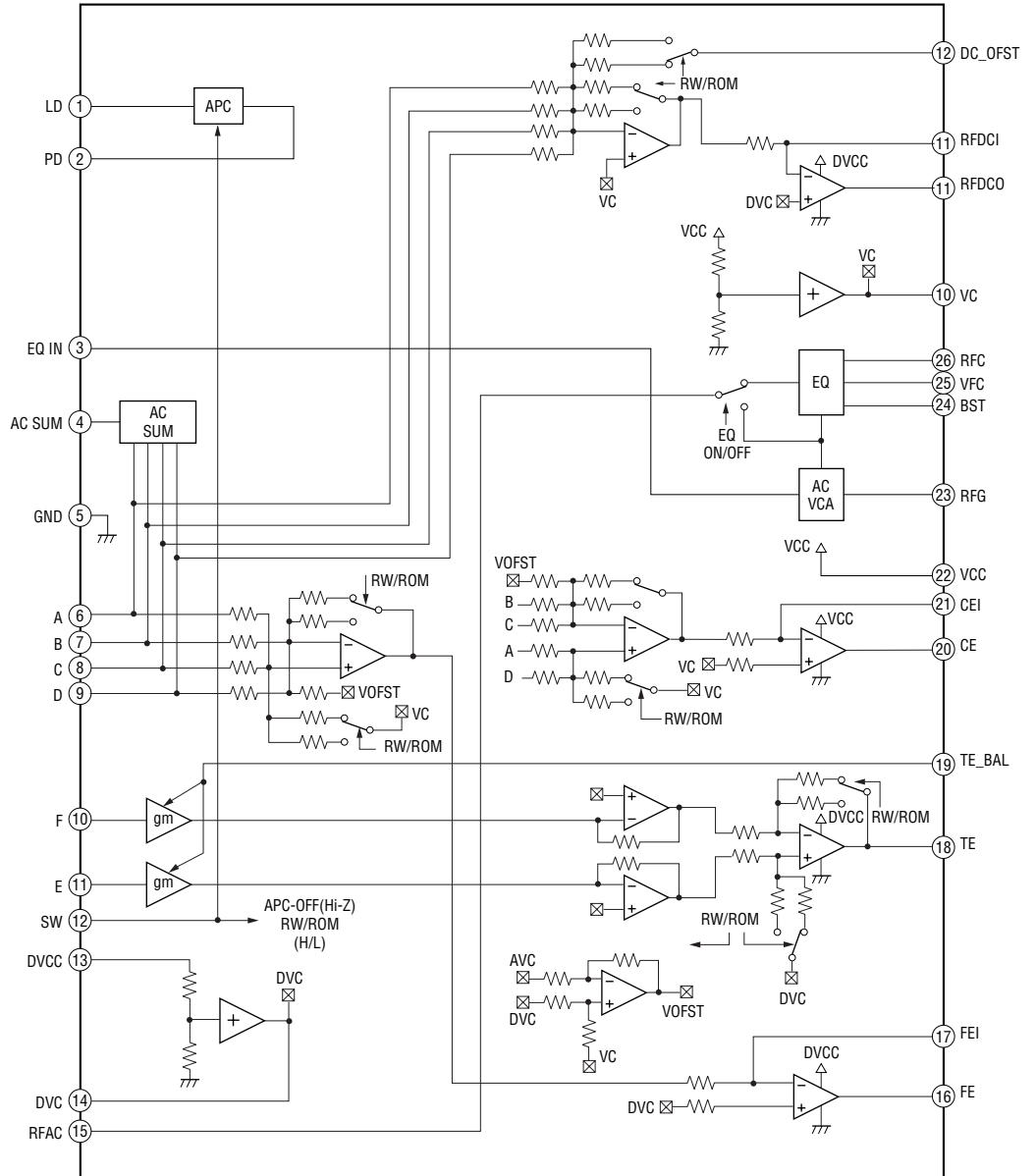

- JUNCTION Board -

IC11 BA6780

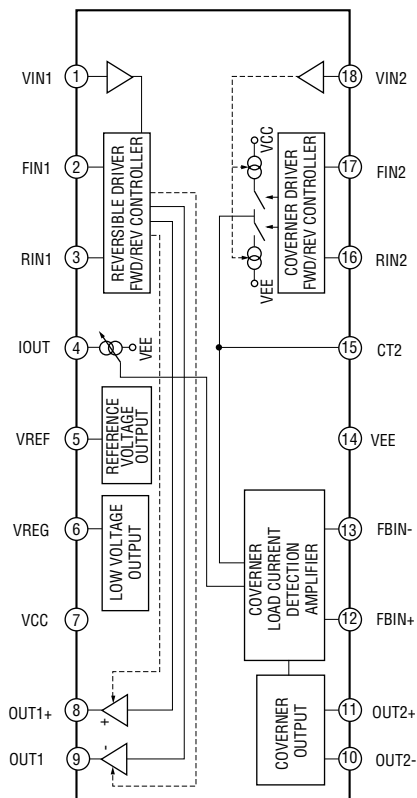

6-10. IC PIN FUNCTION DESCRIPTION

• BD BOARD IC101 CXD2587Q

(DIGITAL SIGNAL PROCESSOR, DIGITAL SERVO PROCESSOR, DIGITAL FILTER, D/A CONVERTER)

Pin No.	Pin Name	I/O	Description
1	SQSO	O	Subcode Q data output to the system controller (IC301)
2	SQCK	I	Subcode Q data reading clock signal input from the system controller (IC301)
3	XRST	I	System reset signal input from the system controller (IC301) “L”: reset
4	SYSM	I	Analog line muting on/off control signal input terminal “H”: line muting on Not used (fixed at “L”)
5	DATA	I	Command serial data input from the system controller (IC301)
6	$\overline{\text{XLAT}}$	I	Command latch pulse input from the system controller (IC301)
7	CLOK	I	Command serial data transfer clock signal input from the system controller (IC301)
8	SENS	O	Internal status monitor output to the system controller (IC301)
9	SCLK	I	SENSE serial data reading clock input from the system controller (IC301)
10	VDD	—	Power supply terminal (+5V) (digital system)
11	ATSK	I/O	Input pin for anti-shock Not used (fixed at “L”)
12	SPOA	I	Microcomputer escape interface input A terminal Not used (fixed at “L”)
13	SPOB	I	Microcomputer escape interface input B terminal Not used (fixed at “L”)
14	XLON	O	Microcomputer escape interface output to the CXA2568M (IC103)
15	WFCK	O	WFCK output terminal Not used (open)
16	XUGF	O	Not used (open)
17	XPCK	O	Not used (open)
18	GFS	O	Not used (open)
19	C2PO	O	Not used (open)
20	SCOR	O	Subcode sync (S0+S1) detection signal output to the system controller (IC301)
21	COUT	I/O	Numbers of track counted signal input/output terminal Not used (open)
22	MIRR	I/O	Mirror signal input/output terminal Not used (open)
23	DFCT	I/O	Defect signal input/output terminal Not used (open)
24	FOK	I/O	Focus OK input/output terminal Not used (open)
25	LOCK	I/O	GFS is sampled by 460 Hz “H” when GFS is “H” Not used (open)
26	MDP	O	Spindle motor (M101) servo drive signal output to the BA5974FP (IC102)
27	SSTP	I	Limit in detect switch (S101) input terminal
28	SFDR	O	Sled servo drive PWM signal (+) output to the BA5974FP (IC102)
29	SRDR	O	Sled servo drive PWM signal (-) output to the BA5974FP (IC102)
30	TFDR	O	Tracking servo drive PWM signal (+) output to the BA5974FP (IC102)
31	TRDR	O	Tracking servo drive PWM signal (-) output to the BA5974FP (IC102)
32	FFDR	O	Focus servo drive PWM signal (+) output to the BA5974FP (IC102)
33	FRDR	O	Focus servo drive PWM signal (-) output to the BA5974FP (IC102)
34	VSS	—	Ground terminal (digital system)
35	TEST	I	Input terminal for the test (fixed at “L”)
36	TES1	I	Input terminal for the test (fixed at “L”)
37	XTSL	I	Input terminal for the system clock frequency setting “L”: 45.1584 MHz, “H”: 22.5792 MHz (fixed at “L” in this set)
38	VC	I	Middle point voltage (+2.5V) input from the CXA2568M (IC103)
39	FE	I	Focus error signal input from the CXA2568M (IC103)
40	SE	I	Sled error signal input from the CXA2568M (IC103)
41	TE	I	Tracking error signal input from the CXA2568M (IC103)
42	CE	I	Command chip enable signal input from the CXA2568M (IC103)

Pin No.	Pin Name	I/O	Description
43	RFDC	I	RF signal input from the CXA2568M (IC103)
44	ADIO	O	Monitor output of the A/D converter input signal Not used (open)
45	AVSS0	—	Ground terminal (digital system)
46	IGEN	I	Stabilized current input for operational amplifiers
47	AVDD0	—	Power supply terminal (+5V) (digital system)
48	ASYO	O	Playback EFM full-swing output terminal
49	ASYI	I	Playback EFM asymmetry comparator voltage input terminal
50	BIAS	I	Playback EFM asymmetry circuit constant current input terminal
51	RFAC	I	EFM signal input from the CXA2568M (IC103)
52	AVSS3	—	Ground terminal (digital system)
53	CLTV	I	Internal VCO control voltage input of the playback master PLL
54	FILO	O	Filter output for master clock of the playback master PLL
55	FILI	I	Filter input for master clock of the playback master PLL
56	PCO	O	Phase comparison output for master clock of the playback EFM master PLL
57	AVDD3	—	Power supply terminal (+5V) (digital system)
58	VSS	—	Ground terminal (digital system)
59	VDD	—	Power supply terminal (+5V) (digital system)
60	DOUT	O	Digital audio signal output to the DIGITAL OUT OPTICAL (IC303)
61	LRCK	O	L/R sampling clock signal (44.1 kHz) output terminal Not used (open)
62	PCMD	O	D/A interface serial data output terminal Not used (open)
63	BCK	O	Bit clock signal (2.8224 MHz) output terminal Not used (open)
64	EMPH	O	De-emphasis control signal output terminal Not used (open)
65	XVDD	—	Power supply terminal (+5V) (crystal oscillator system)
66	XTAI	I	System clock input terminal (16.9344 MHz)
67	XTAO	O	System clock output terminal (16.9344 MHz)
68	XVSS	—	Ground terminal (crystal oscillator system)
69	AVDD1	—	Power supply terminal (+5V) (analog system)
70	AOUT1	O	L-ch analog audio signal output terminal
71	AIN1	I	L-ch operational amplifiers input terminal
72	LOUT1	O	L-ch line output terminal
73	AVSS1	—	Ground terminal (analog system)
74	AVSS2	—	Ground terminal (analog system)
75	LOUT2	O	R-ch line output terminal
76	AIN2	I	R-ch operational amplifiers input terminal
77	AOUT2	O	R-ch analog audio signal output terminal
78	AVDD2	—	Power supply terminal (+5V) (analog system)
79	RMUT	O	R-ch line muting on/off control signal output terminal
80	LMUT	O	L-ch line muting on/off control signal output terminal

• MAIN BOARD IC301 CXP82532-013Q
(SYSTEM CONTROLLER, FLUORESCENT INDICATOR TUBE DRIVER, KEY CONTROL)

Pin No.	Pin Name	I/O	Description
1	BUSIN	I	Sircs remote control signal input terminal Not used (pull up)
2	RMIN	I	Remote control signal input from the remote control receiver (IC802)
3	NC	I	Not used (open)
4	XLT	O	Serial data latch pulse signal output to the CXD2587Q (IC101)
5	LDON	O	Laser diode ON/OFF output
6	TSENS	I/O	Detect signal input from the table sensor (D10)
7	DA CS	I/O	DA CS
8	CLK	I/O	Serial data transfer clock signal output to the CXD2587Q (IC101)
9	LDON/RW	I/O	Laser diode ON/OFF output
10	DATA	I/O	Serial data output to the CXD2587Q (IC101)
11	SQCK	I/O	Sub-code Q data reading clock signal output to the CXD2587Q (IC101)
12	SUBQ	I/O	Sub-code Q data signal input from the CXD2587Q (IC101)
13	NC	O	Not used (open)
14	OUT SW	I/O	Detect signal input from the open/close detect switch (S11)
15	S1	I/O	Detect signal input from the tray address detect switch (S200)
16	S2	I/O	Detect signal input from the tray address detect switch (S200)
17	NC	I/O	Not used (open)
18	TBLL	I/O	Table motor drive signal (counterclockwise) output to the BA6780 (IC11)
19	TBLR	I/O	Table motor drive signal (clockwise) output to the BA6780 (IC11)
20	LD IN	I/O	Loading motor (M11) drive signal output to the BA6780 (IC11) *1
21	LD OUT	I/O	Loading motor (M11) drive signal output to the BA6780 (IC11) *1
22	NC	I/O	Not used (open)
23	NC	I/O	Not used (open)
24	TEST	I/O	Key input terminal (A/D input)
25	KEY3	I/O	Key input terminal (A/D input) (S812 to S816)
26	KEY4	I/O	Key input terminal (A/D input) (S817 to S821)
27	KEY5	I/O	Key input terminal (A/D input) (S806 to S810)
28	KEY6	I/O	Key input terminal (A/D input) (S801 to S805)
29	NC	I/O	Not used (open)
30	RST	I/O	System reset signal input from the reset signal generator (IC601) "L" reset For several hundreds msec. after the power supply rises, "L" is input, then it changes to "H"
31	EXTAL	I	Main system clock input terminal (10 MHz)
32	XTAL	O	Main system clock output terminal (10 MHz)
33	VSS	—	Ground terminal
34	NC	O	Not used (open)
35	NC	O	Not used (open)
36	NC	O	Not used (open)
37	NC	O	Not used (open)

*1 Loading motor (M11) control

Terminal	Operation			
	OFF	OFF	IN	BRAKE
LOAD IN (pin ⑳)	"L"	"L"	"H"	"H"
LOAD OUT (pin ㉑)	"L"	"H"	"L"	"H"

Pin No.	Pin Name	I/O	Description
38 to 57	P1 to P20	O	Segment drive signal output to the fluorescent indicator tube (FL801)
58 to 62	NC	O	Not used (open)
63 to 70	G1 to G8	O	Grid drive signal output to the fluorescent indicator tube (FL801)
71	VG	—	Power supply terminal (−30V) (for fluorescent indicator tube drive)
72	VDD	—	Power supply terminal (+5V)
73 to 75	NC	O	Not used (open)
76	AFADJ	I	Setting terminal for the test mode “L” active
77	BUSOUT	O	Sircs remote control signal output terminal Not used (open)
78	DSSENS	I	Detect signal input from the disc sensor (D11)
79	SENS	I	Internal status (SENSE) signal input from the CXD2587Q (IC101)
80	SCOR	I	Sub-code sync (S0+S1) detection signal input from the CXD2587Q (IC101)

SECTION 7 EXPLODED VIEWS

NOTE:

- -XX and -X mean standardized parts, so they may have some difference from the original one.

• Color Indication of Appearance Parts

Example:

KNOB, BALANCE (WHITE) . . . (RED)

↑ ↑
Parts Color Cabinet's Color

• Abbreviation

- AUS : Australian model
- CND : Canadian model
- EA : Saudi Arabia model
- SP : Singapore model

- Items marked “*” are not stocked since they are seldom required for routine service. Some delay should be anticipated when ordering these items.
- The mechanical parts with no reference number in the exploded views are not supplied.
- Accessories and packing materials are given in the last of the electrical parts list.

The components identified by mark Δ or dotted line with mark Δ are critical for safety. Replace only with part number specified.

Les composants identifiés par une marque Δ sont critiques pour la sécurité. Ne les remplacer que par une pièce portant le numéro spécifié.

7-1. CASE SECTION

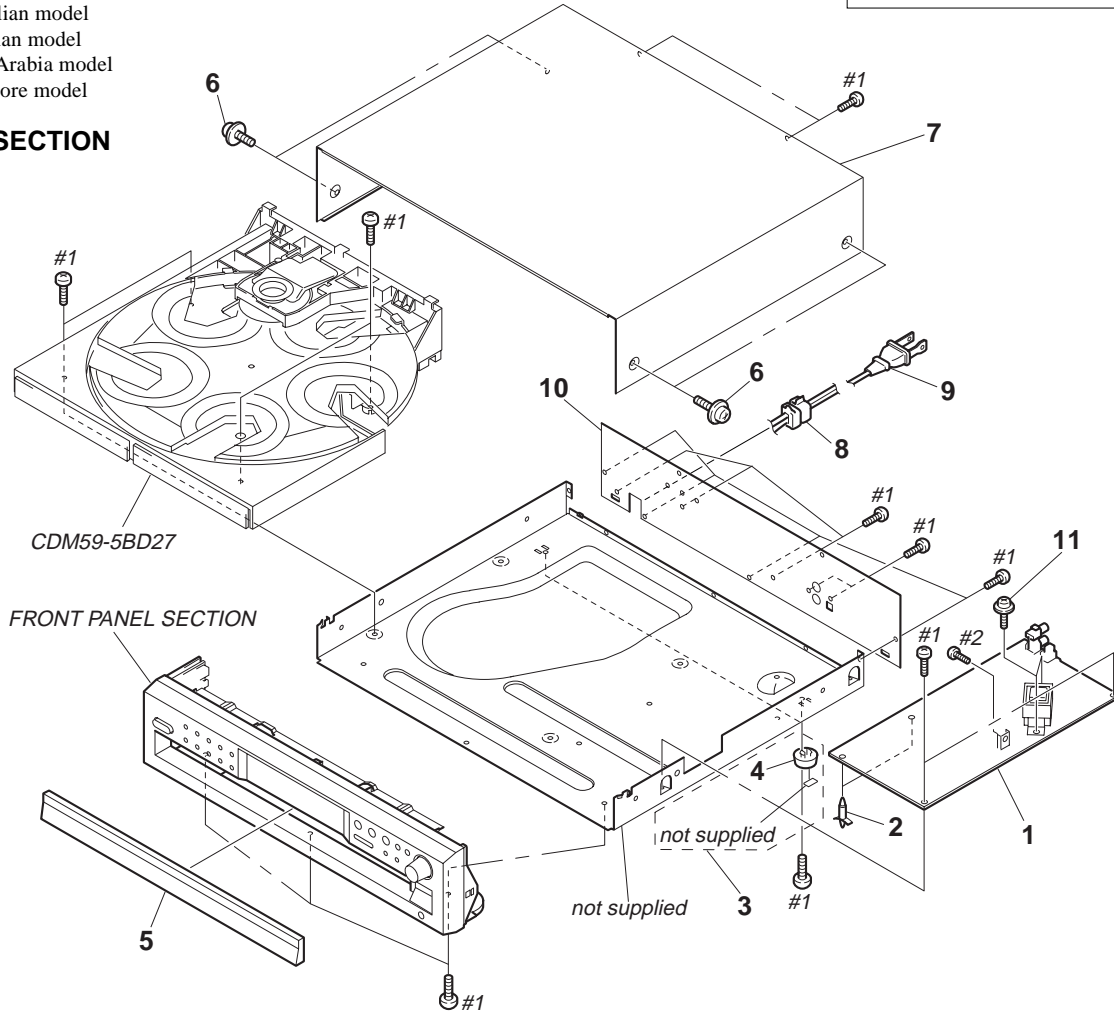

Ref. No.	Part No.	Description	Remark	Ref. No.	Part No.	Description	Remark
1	A-4725-570-A	MAIN MOUNTED PC BOARD (CE275)		Δ 9	1-575-651-21	CORD,POWER (CE375:AEP/UK/SP)	
1	A-4725-571-A	MAIN MOUNTED PC BOARD (CE375:US/CND)		Δ 9	1-696-845-11	CORD,POWER (CE275:AUS,CE375:AUS)	
1	A-4725-579-A	MAIN MOUNTED PC BOARD (CE375:AUS/AEP/UK/SP)		Δ 9	1-777-071-41	CORD,POWER (CE375:AEP/UK/SP)	
1	A-4725-581-A	MAIN MOUNTED PC BOARD (CE375:E)		Δ 9	1-783-528-21	CORD,POWER (TRACKING)(CE375:E)	
2	4-943-687-01	HOLDER, PC BOARD		Δ 9	1-783-531-31	CORD,POWER (CE275:US/CND,CE375US/CND)	
3	X-4953-448-1	FOOT ASSY		10	4-233-718-01	PANEL, BACK (CE375:US)	
4	4-232-237-01	FOOT(DIA. 30)		10	4-233-718-11	PANEL, BACK (CE375:CND)	
5	4-231-683-01	PANEL, LOADING(BLACK) (CE275,CE375:US/CND/AUS/AEP/UK/SP/E)		10	4-233-718-21	PANEL, BACK (CE375:AEP)	
5	4-231-683-21	PANEL, LOADING(SILVER)(CE375:AEP)		10	4-233-718-31	PANEL, BACK (CE375:UK)	
6	4-210-291-01	SCREW(CASE 3 TP2)(BLACK) (CE275,CE375:US/CND/AUS/AEP/UK/SP/E)		10	4-233-718-41	PANEL, BACK (CE375:AUS)	
6	4-210-291-11	SCREW(CASE 3 TP2)(SILVER)(CE375:AEP)		10	4-233-718-51	PANEL, BACK (CE375:E)	
7	4-231-686-11	CASE(409538)(BLACK) (CE275,CE375:US/CND/AUS/AEP/UK/SP/E)		10	4-233-718-61	PANEL, BACK (CE375:SP)	
7	4-231-686-31	CASE(409538)(SILVER)(CE375:AEP)		10	4-233-719-01	PANEL, BACK (CE275:US)	
8	3-703-571-11	BUSHING (S)(4516), CORD (CE375:E)		10	4-233-719-11	PANEL, BACK (CE275:CND)	
* 8	3-703-244-00	BUSHING (2104), CORD (CE275,CE375:US/CND/AUS/AEP/UK/SP)		10	4-233-719-21	PANEL, BACK (CE275:AUS)	
				11	3-703-249-01	SCREW, S TIGHT, +PTTWH 3X6	
				Δ T601	1-435-342-11	TRANSFORMER, POWER (CE275:US/CND,CE375:US/CND)	
				Δ T601	1-435-343-11	TRANSFORMER, POWER (CE275:AUS,CE375:AUS/AEP/UK/SP)	
				Δ T601	1-435-344-11	TRANSFORMER, POWER (CE375:E)	

7-2. FRONT PANEL SECTION

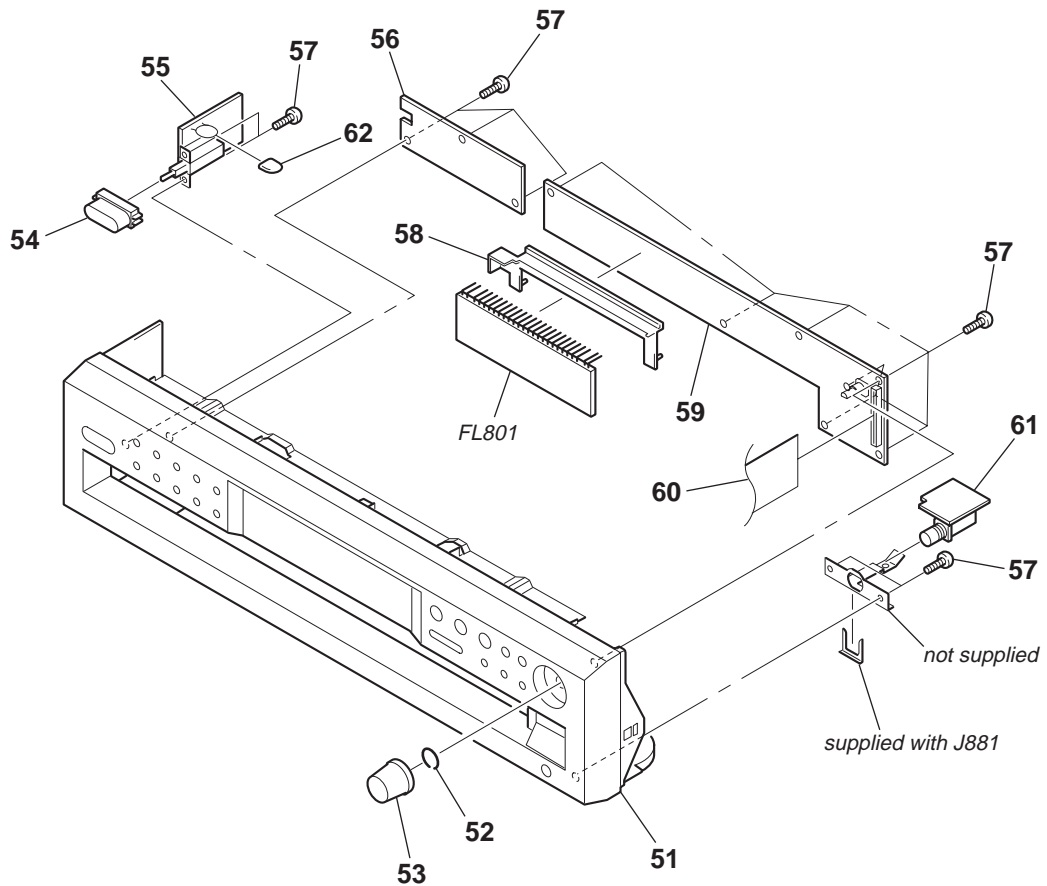

Ref. No.	Part No.	Description	Remark	Ref. No.	Part No.	Description	Remark
51	A-4953-509-1	PANEL ASSY, FRONT (CE375:US/CND)		54	4-231-973-11	BUTTON (POWER)(CE375:AEP)	
51	X-4953-510-1	PANEL ASSY, FRONT(SILVER)(CE375:AEP)		55	1-681-141-21	POWER SW BOARD	
51	X-4953-511-1	PANEL ASSY, FRONT(BLACK)(CE275:US/CND)		56	1-681-140-21	KEY BOARD	
51	X-4953-519-1	PANEL ASSY, FRONT(BLACK) (CE375:AUS/AEP/UK/SP/E)		57	4-951-620-01	SCREW (2.6X8), +BVTP	
51	X-4953-520-1	PANEL ASSY, FRONT(BLACK)(CE275:AUS)		58	4-231-690-01	HOLDER (FL A)	
52	3-354-981-11	SPRING (SUS), RING		59	1-681-139-11	DISPLAY BOARD	
53	4-231-928-01	KNOB(AMS)(BLACK) (CE275,CE375:US/CND/AUS/AEP/UK/SP/E)		60	1-792-486-11	WIRE(FLAT TYPE)(37 CORE)	
53	4-231-928-11	KNOB(AMS)(SILVER)(CE375:AEP)		61	1-681-142-21	HEADPHONE BOARD	
54	4-231-973-01	BUTTON (POWER)(BLACK) (CE275,CE375:US/CND/AUS/AEP/UK/SP/E)		62	4-374-846-31	COVER, CAPACITOR, CAP TYPE (CE275:AUS,CE375:AUS/AEP/UK/SP/E)	
				FL801	1-517-946-21	INDICATOR TUBE, FLUORESCENT	

7-3. CD MECHANISM SECTION (1)
(CDM59-5BD27)

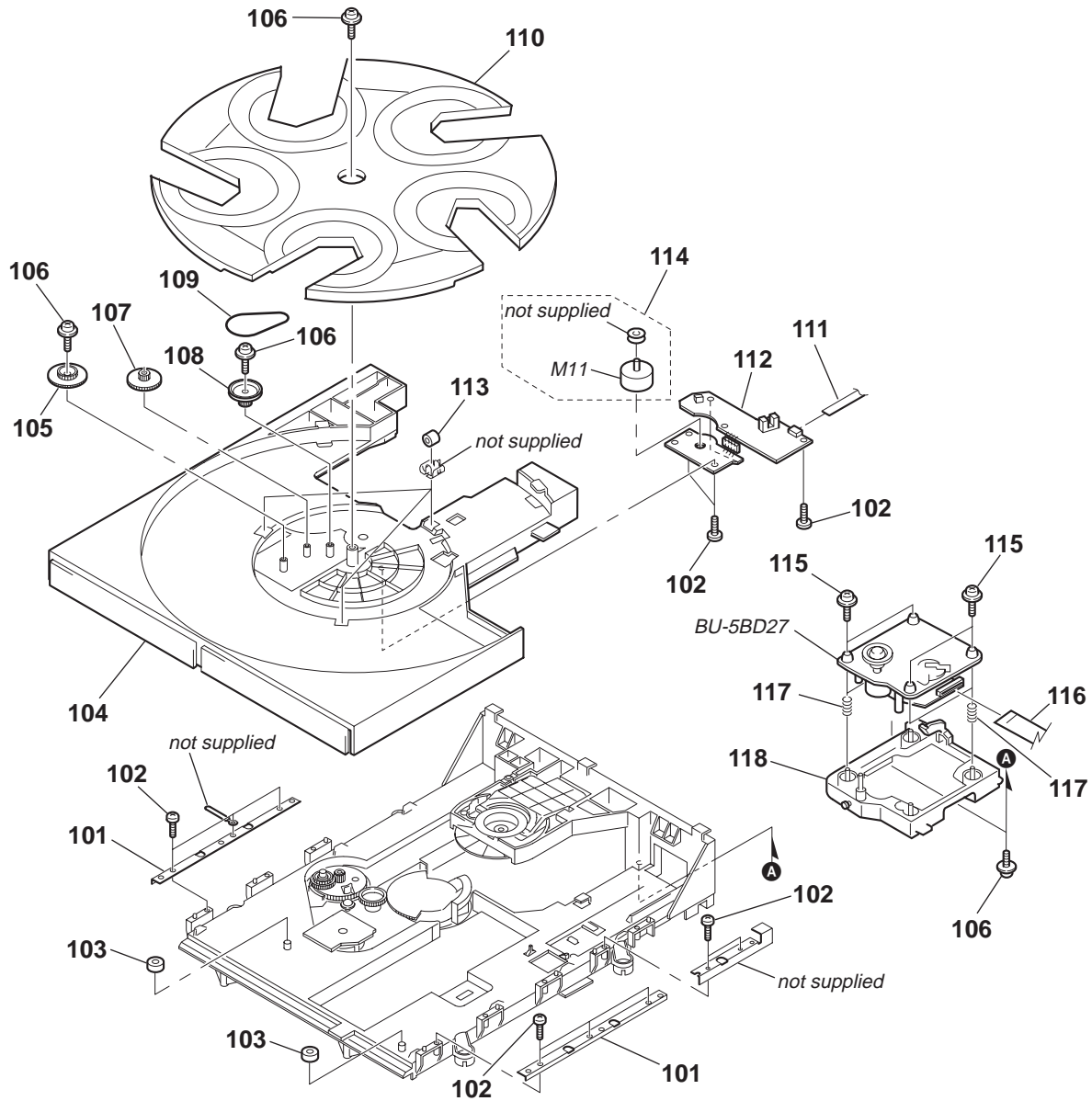

Ref. No.	Part No.	Description	Remark	Ref. No.	Part No.	Description	Remark
101	4-224-619-01	BRACKET (GUIDE)		111	1-791-930-11	WIRE (FLAT TYPE)(6 CORE)	
102	4-218-253-31	SCREW (M2.6), +BTTP		112	1-676-245-11	SENSOR BOARD	
* 103	4-951-619-01	CUSHION (A)		* 113	X-4924-457-1	ROLLER ASSY	
104	4-224-602-01	TABLE		114	A-4672-867-A	MOTOR ASSY, ROTARY	
105	4-224-617-01	GEAR (RM-E)		115	4-985-672-01	SCREW (+PTPWH M2.6), FLOATING	
106	4-218-252-51	SCREW (+PTPWH M2.6), FLOATING		116	1-757-648-11	WIRE (FLAT TYPE)(21 CORE)	
107	4-224-616-01	GEAR (RM-M)		117	4-959-996-01	SPRING (932), COMPRESSION	
108	4-224-615-03	GEAR (RM-B)		118	X-4952-312-1	HOLDER (BU) ASSY	
109	4-225-328-01	BELT (ROTARY)					
110	4-224-603-01	TRAY					

7-4. CD MECHANISM SECTION (2)
(CDM59-5BD27)

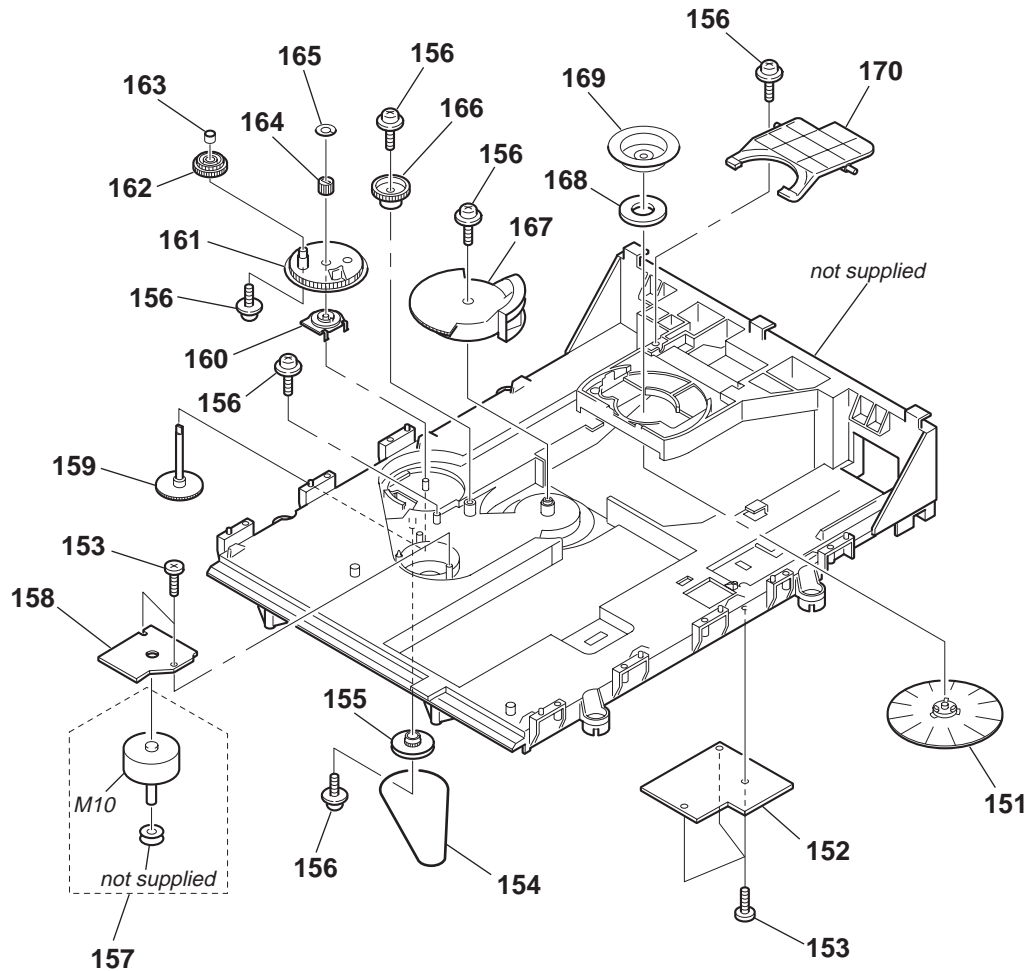

Ref. No.	Part No.	Description	Remark	Ref. No.	Part No.	Description	Remark
151	X-4952-019-2	PULLEY (A) ASSY, CHUCKING		161	4-224-607-01	GEAR, SWING	
152	1-676-246-11	JUNCTION BOARD		162	4-224-609-01	GEAR (LOADING C)	
153	4-218-253-31	SCREW (M2.6), +BTTP		163	4-224-608-01	COLLAR, SWING	
154	4-225-885-01	BELT (LOADING)		164	4-224-611-01	GEAR (LOADING B)	
155	4-225-844-01	GEAR (LOADING A)		165	3-016-533-01	WASHER (FR), STOPPER	
156	4-218-252-51	SCREW (+PTPWH M2.6), FLOATING		166	4-224-606-01	GEAR (RV)	
157	A-4672-879-A	MOTOR ASSY, LOADING		167	4-224-605-01	GEAR (U/D)	
158	1-676-244-11	LOADING MOTOR BOARD		168	1-471-061-11	MAGNET ASSY	
159	4-224-613-01	GEAR (SHAFT)		169	4-221-688-01	PULLEY (B), CHUCKING	
160	1-418-746-11	ENCODER, ROTARY		170	4-224-618-01	LEVER (LIFTER)	

7-5. BASE UNIT SECTION
(BU-5BD27)

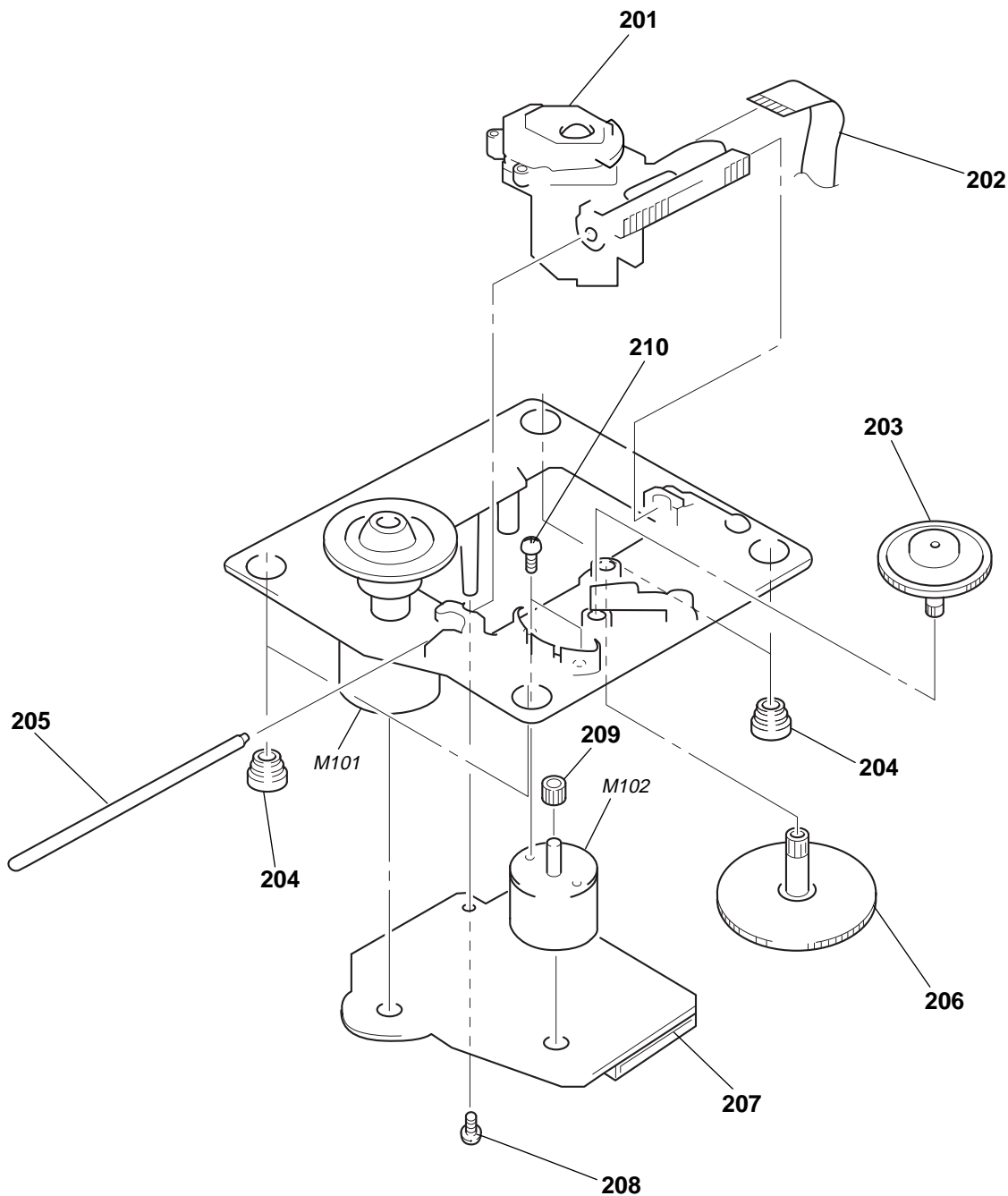

<p>The components identified by mark \triangle or dotted line with mark \triangle are critical for safety. Replace only with part number specified.</p>	<p>Les composants identifiés par une marque \triangle sont critiques pour la sécurité. Ne les remplacer que par une pièce portant le numéro spécifié.</p>
---	--

Ref. No.	Part No.	Description	Remark	Ref. No.	Part No.	Description	Remark
\triangle 201	1-796-033-11	LIGHT PICK UP (PXR-104X)		206	4-917-564-01	GEAR (P), FLATNESS	
202	1-782-817-11	WIRE (FLAT TYPE)(16 CORE)		207	A-4725-568-A	BDMOUNTED PC BOARD (A)	
203	4-917-567-01	GEAR (M)		208	4-951-620-01	SCREW (2.6X8), +BVTP	
204	4-951-940-01	INSULATOR (BU)		209	4-917-566-01	GEAR (S)	
205	4-917-565-01	SHAFT, SLED		210	3-713-786-51	SCREW +P 2X3	
				M101	X-4917-523-3	MOTOR ASSY (SPINDLE)	
				M102	X-4917-504-1	MOTOR ASSY (SLED)	

SECTION 8 ELECTRICAL PARTS LIST

BD

NOTE:

- Due to standardization, replacements in the parts list may be different from the parts specified in the diagrams or the components used on the set.
- -XX and -X mean standardized parts, so they may have some difference from the original one.
- RESISTORS
All resistors are in ohms.
METAL: Metal-film resistor.
METAL OXIDE: Metal oxide-film resistor.
F: nonflammable
- Abbreviation
AUS : Australian model EA : Saudi Arabia model
CND : Canadian model SP : Singapore model

- Items marked “*” are not stocked since they are seldom required for routine service. Some delay should be anticipated when ordering these items.
- SEMICONDUCTORS
In each case, u: μ , for example:
uA. . . : μ A. . . uPA. . . : μ PA. . .
uPB. . . : μ PB. . . uPC. . . : μ PC. . .
uPD. . . : μ PD. . .
- CAPACITORS
uF: μ F
- COILS
uH: μ H

The components identified by mark Δ or dotted line with mark Δ are critical for safety. Replace only with part number specified.

Les composants identifiés par une marque Δ sont critiques pour la sécurité. Ne les remplacer que par une pièce portant le numéro spécifié.

When indicating parts by reference number, please include the board.

Ref. No.	Part No.	Description	Remark	Ref. No.	Part No.	Description	Remark
	A-4725-568-A	BD BOARD, COMPLETE *****		C193	1-162-920-11	CERAMIC CHIP 27PF	5% 50V
		< CAPACITOR >		C194	1-162-918-11	CERAMIC CHIP 18PF	5.00% 50V
C101	1-164-315-11	CERAMIC CHIP 470PF	5.00% 50V	C199	1-164-156-11	CERAMIC CHIP 0.1UF	25V
C102	1-164-156-11	CERAMIC CHIP 0.1UF	25V			< CONNECTOR >	
C103	1-164-315-11	CERAMIC CHIP 470PF	5.00% 50V	CN101	1-784-360-11	CONNECTOR,FFC(LIF(NON-ZIF))21P	
C110	1-126-206-11	ELECT CHIP 100UF	20% 6.3V	CN102	1-777-937-11	CONNECTOR, FFC/FPC 16P	
C111	1-164-156-11	CERAMIC CHIP 0.1UF	25V			< FERRITE BEAD >	
C112	1-164-156-11	CERAMIC CHIP 0.1UF	25V	FB191	1-216-864-91	SHORT 0	
C120	1-164-156-11	CERAMIC CHIP 0.1UF	25V			< IC >	
C121	1-162-970-11	CERAMIC CHIP 0.01UF	10% 25V	IC101	8-752-386-85	IC CXD2587Q	
C122	1-117-863-11	CERAMIC CHIP 0.47UF	10.00% 6.3V	IC131	8-752-089-74	IC CXA2581N-T4	
C123	1-162-927-11	CERAMIC CHIP 100PF	5% 50V	IC150	8-759-829-14	IC AN4800SB	
C124	1-162-967-11	CERAMIC CHIP 0.0033UF	10% 50V			< MOTOR >	
C125	1-162-965-11	CERAMIC CHIP 0.0015UF	10% 50V	M101	X-4917-523-3	MOTOR ASSY (SPINDLE)	
C126	1-107-826-11	CERAMIC CHIP 0.1UF	10.00% 16V	M102	X-4917-504-1	MOTOR ASSY (SLED)	
C130	1-164-505-11	CERAMIC CHIP 2.2UF	16V			< TRANSISTOR >	
C131	1-164-505-11	CERAMIC CHIP 2.2UF	16V	Q131	8-729-010-08	TRANSISTOR MSB710-R	
C132	1-164-505-11	CERAMIC CHIP 2.2UF	16V	Q132	8-729-600-22	TRANSISTOR 2SA1235-F	
C133	1-126-607-11	ELECT CHIP 47UF	20% 4V			< RESISTOR >	
C134	1-126-607-11	ELECT CHIP 47UF	20% 4V	R101	1-216-835-11	METAL CHIP 15K 5% 1/16W	
C136	1-107-826-11	CERAMIC CHIP 0.1UF	10.00% 16V	R102	1-216-845-11	METAL CHIP 100K 5% 1/16W	
C137	1-126-209-11	ELECT CHIP 100UF	20.00% 4V	R103	1-216-835-11	METAL CHIP 15K 5% 1/16W	
C138	1-162-964-11	CERAMIC CHIP 0.001UF	10% 50V	R110	1-216-821-11	METAL CHIP 1K 5% 1/16W	
C139	1-162-921-11	CERAMIC CHIP 33PF	5% 50V	R111	1-216-809-11	METAL CHIP 100 5% 1/16W	
C140	1-164-505-11	CERAMIC CHIP 2.2UF	16V	R112	1-216-833-11	METAL CHIP 10K 5% 1/16W	
C145	1-162-908-11	CERAMIC CHIP 3PF	0.25PF 50V	R120	1-216-839-11	METAL CHIP 33K 5% 1/16W	
C150	1-126-204-11	ELECT CHIP 47UF	20% 16V	R121	1-216-833-11	METAL CHIP 10K 5% 1/16W	
C151	1-164-156-11	CERAMIC CHIP 0.1UF	25V	R122	1-216-845-11	METAL CHIP 100K 5% 1/16W	
C152	1-162-919-11	CERAMIC CHIP 22PF	5% 50V	R123	1-216-857-11	METAL CHIP 1M 5% 1/16W	
C153	1-162-919-11	CERAMIC CHIP 22PF	5% 50V	R125	1-216-827-11	METAL CHIP 3.3K 5% 1/16W	
C154	1-162-964-11	CERAMIC CHIP 0.001UF	10% 50V	R126	1-216-833-11	METAL CHIP 10K 5% 1/16W	
C158	1-164-172-11	CERAMIC CHIP 0.0056UF	10.00% 25V	R127	1-216-821-11	METAL CHIP 1K 5% 1/16W	
C171	1-126-206-11	ELECT CHIP 100UF	20% 6.3V	R129	1-216-815-11	METAL CHIP 330 5% 1/16W	
C172	1-164-156-11	CERAMIC CHIP 0.1UF	25V	R134	1-216-853-11	METAL CHIP 470K 5% 1/16W	
C173	1-162-928-11	CERAMIC CHIP 120PF	5% 50V	R135	1-216-836-11	METAL CHIP 18K 5% 1/16W	
C174	1-115-412-11	CERAMIC CHIP 680PF	5.00% 25V	R136	1-216-836-11	METAL CHIP 18K 5% 1/16W	
C181	1-126-206-11	ELECT CHIP 100UF	20% 6.3V	R137	1-216-797-11	METAL CHIP 10 5% 1/16W	
C182	1-164-156-11	CERAMIC CHIP 0.1UF	25V				
C183	1-162-928-11	CERAMIC CHIP 120PF	5% 50V				
C184	1-115-412-11	CERAMIC CHIP 680PF	5.00% 25V				
C191	1-126-205-11	ELECT CHIP 47UF	20% 6.3V				
C192	1-164-156-11	CERAMIC CHIP 0.1UF	25V				

CDP-CE275/CE375

BD **DISPLAY** **HP**

Ref. No.	Part No.	Description	Remark
R138	1-216-798-11	RES-CHIP	12 5% 1/16W
R139	1-216-847-11	METAL CHIP	150K 5% 1/16W
R140	1-216-854-11	METAL CHIP	560K 5% 1/16W
R141	1-216-840-11	METAL CHIP	39K 5% 1/16W
R142	1-216-841-11	METAL CHIP	47K 5% 1/16W
R143	1-216-855-11	METAL CHIP	680K 5% 1/16W
R144	1-216-846-11	METAL CHIP	120K 5% 1/16W
R145	1-216-830-11	METAL CHIP	5.6K 5% 1/16W
R146	1-216-845-11	METAL CHIP	100K 5% 1/16W
R149	1-216-821-11	METAL CHIP	1K 5% 1/16W
R151	1-216-845-11	METAL CHIP	100K 5% 1/16W
R152	1-216-833-11	METAL CHIP	10K 5% 1/16W
R153	1-216-864-91	SHORT	0
R155	1-216-836-11	METAL CHIP	18K 5% 1/16W
R171	1-218-720-11	METAL CHIP	15K 0.5% 1/16W
R172	1-218-720-11	METAL CHIP	15K 0.5% 1/16W
R173	1-218-720-11	METAL CHIP	15K 0.5% 1/16W
R174	1-216-809-11	METAL CHIP	100 5% 1/16W
R181	1-218-720-11	METAL CHIP	15K 0.5% 1/16W
R182	1-218-720-11	METAL CHIP	15K 0.5% 1/16W
R183	1-218-720-11	METAL CHIP	15K 0.5% 1/16W
R184	1-216-809-11	METAL CHIP	100 5% 1/16W
R191	1-216-817-11	METAL CHIP	470 5% 1/16W
R192	1-216-797-11	METAL CHIP	10 5% 1/16W
< COMPOSITION CIRCUIT BLOCK >			
RB101	1-233-576-11	RES, CHIP NETWORK 100	
RB102	1-233-576-11	RES, CHIP NETWORK 100	
< SWITCH >			
S101	1-572-085-11	SWITCH, LEAF	
< VIBRATOR >			
X191	1-767-408-21	VIBRATOR, CRYSTAL (16MHZ)	
X191	1-767-430-11	VIBRATOR, CRYSTAL (16MHZ)	

	1-681-139-11	DISPLAY BOARD (CE275,CE375:US/CND)	*****
	1-681-139-21	DISPLAY BOARD (CE375:AUS/AEP/UK/SP/E)	*****
	2-389-320-01	CUSHION	
	4-231-690-01	HOLDER (FL A)	
< CONNECTOR >			
* CN810	1-764-700-11	SOCKET, CONNECTOR 37P	
CN811	1-750-194-11	CONNECTOR, BOARD TO BOARD 4P	
< FILTER >			
FL801	1-517-946-21	INDICATOR TUBE, FLUORESCENT	
< IC >			
IC802	8-759-827-70	IC NJL64H400A-1	

Ref. No.	Part No.	Description	Remark
< RESISTOR >			
R811	1-249-415-11	CARBON	680 5% 1/4W F
R812	1-249-417-11	CARBON	1K 5% 1/4W F
R813	1-249-419-11	CARBON	1.5K 5% 1/4W F
R814	1-249-421-11	CARBON	2.2K 5% 1/4W F
R815	1-247-843-11	CARBON	3.3K 5% 1/4W
R816	1-249-427-11	CARBON	6.8K 5% 1/4W F
R817	1-249-415-11	CARBON	680 5% 1/4W F
R818	1-249-417-11	CARBON	1K 5% 1/4W F
R819	1-249-419-11	CARBON	1.5K 5% 1/4W F
R820	1-249-421-11	CARBON	2.2K 5% 1/4W F
R821	1-247-843-11	CARBON	3.3K 5% 1/4W
R822	1-249-427-11	CARBON	6.8K 5% 1/4W F
R851	1-247-807-31	CARBON	100 5% 1/4W
R852	1-247-807-31	CARBON	100 5% 1/4W
< SWITCH >			
S801	1-771-349-21	SWITCH, KEYBOARD (▷)	
S802	1-771-349-21	SWITCH, KEYBOARD (⏏)	
S803	1-771-349-21	SWITCH, KEYBOARD (□)	
S804	1-771-349-21	SWITCH, KEYBOARD (EX-CHANGE)	
S805	1-771-349-21	SWITCH, KEYBOARD (DISC SKIP)	
S806	1-771-349-21	SWITCH, KEYBOARD (<<<)	
S807	1-771-349-21	SWITCH, KEYBOARD (▶▶▶)	
S808	1-771-349-21	SWITCH, KEYBOARD (EDIT)	
S809	1-771-349-21	SWITCH, KEYBOARD (CHECK)	
S810	1-771-349-21	SWITCH, KEYBOARD (CLEAR)	
S811	1-771-349-21	SWITCH, KEYBOARD (≡)	
S825	1-475-543-11	ENCODER, ROTARY (JOG)	

	1-681-142-11	HP BOARD (CE375:US/CND)	*****
	1-681-142-21	HP BOARD (CE375:AUS/AEP/UK/SP/E)	*****
< CAPACITOR >			
C881	1-162-294-31	CERAMIC	0.001UF 10% 50V (CE375)
C882	1-162-294-31	CERAMIC	0.001UF 10% 50V (CE375)
C883	1-164-159-11	CERAMIC	0.1UF 50V (CE375)
< JACK >			
J881	1-770-306-11	JACK (LARGE TYPE) (CE375)	
< RESISTOR >			
R881	1-249-401-11	CARBON	47 5% 1/4W F (CE375)
R882	1-249-401-11	CARBON	47 5% 1/4W F (CE375)

Ref. No.	Part No.	Description	Remark	Ref. No.	Part No.	Description	Remark
	1-681-140-11	KEY BOARD (CE275,CE375:US/CND) *****			A-4725-570-A	MAIN BOARD, COMPLETE (CE275) *****	
	1-681-140-21	KEY BOARD (CE375:AUS/AEP/UK/SP/E) *****			A-4725-571-A	MAIN BOARD, COMPLETE (CE375:US/CND) *****	
		< CAPACITOR >			A-4725-579-A	MAIN BOARD, COMPLETE (CE375:AUS/AEP/UK/SP) *****	
C851	1-104-665-11	ELECT	100UF 20.00% 10V		A-4725-581-A	MAIN BOARD, COMPLETE (CE375:E) *****	
		< CONNECTOR >			7-685-871-01	SCREW +BVTT 3X6 (S)	
CN812	1-750-185-11	CONNECTOR, BOARD TO BOARD 4P				< CAPACITOR >	
		< RESISTOR >		R824	1-249-415-11	CARBON 680 5% 1/4W F	
				R825	1-249-417-11	CARBON 1K 5% 1/4W F	
				R826	1-249-419-11	CARBON 1.5K 5% 1/4W F	
				R827	1-249-421-11	CARBON 2.2K 5% 1/4W F	
				R830	1-249-415-11	CARBON 680 5% 1/4W F	
				R831	1-249-417-11	CARBON 1K 5% 1/4W F	
				R832	1-249-419-11	CARBON 1.5K 5% 1/4W F	
				R833	1-249-421-11	CARBON 2.2K 5% 1/4W F	
		< SWITCH >					
S812	1-771-349-21	SWITCH, KEYBOARD (DISC 5)		C301	1-161-494-00	CERAMIC 0.022UF 25V	
S812	1-771-349-41	SWITCH, KEYBOARD (DISC 5)		C302	1-104-665-11	ELECT 100UF 20.00% 10V	
S813	1-771-349-21	SWITCH, KEYBOARD (DISC 4)		C303	1-161-494-00	CERAMIC 0.022UF 25V	
S813	1-771-349-41	SWITCH, KEYBOARD (DISC 4)		C304	1-164-159-11	CERAMIC 0.1UF 50V	
S814	1-771-349-21	SWITCH, KEYBOARD (DISC 3)		C325	1-161-494-00	CERAMIC 0.022UF 25V	
S814	1-771-349-41	SWITCH, KEYBOARD (DISC 3)		C326	1-104-665-11	ELECT 100UF 20.00% 10V	
S815	1-771-349-21	SWITCH, KEYBOARD (DISC 2)		C351	1-126-963-11	ELECT 4.7UF 20.00% 50V	
S815	1-771-349-41	SWITCH, KEYBOARD (DISC 2)		C401	1-126-965-11	ELECT 22UF 20.00% 50V	
S816	1-771-349-21	SWITCH, KEYBOARD (DISC 1)		C404	1-126-965-11	ELECT 22UF 20.00% 50V	
S816	1-771-349-41	SWITCH, KEYBOARD (DISC 1)		C407	1-162-290-31	CERAMIC 470PF 10% 50V	
S817	1-771-349-21	SWITCH, KEYBOARD (TIMER)		C451	1-126-933-11	ELECT 100UF 20.00% 16V (CE375)	
S817	1-771-349-41	SWITCH, KEYBOARD (TIMER)		C501	1-126-965-11	ELECT 22UF 20.00% 50V	
S818	1-771-349-21	SWITCH, KEYBOARD (REPEAT)		C504	1-126-965-11	ELECT 22UF 20.00% 50V	
S818	1-771-349-41	SWITCH, KEYBOARD (REPEAT)		C507	1-162-290-31	CERAMIC 470PF 10% 50V	
S819	1-771-349-21	SWITCH, KEYBOARD (FADER)		C551	1-126-933-11	ELECT 100UF 20.00% 16V (CE375)	
S819	1-771-349-41	SWITCH, KEYBOARD (FADER)		C602	1-126-937-11	ELECT 4700UF 20.00% 16V	
S820	1-771-349-21	SWITCH, KEYBOARD (P.SEARCH)		C603	1-126-767-11	ELECT 1000UF 20.00% 16V	
S820	1-771-349-41	SWITCH, KEYBOARD (P.SEARCH)		C608	1-126-934-11	ELECT 220UF 20.00% 10V	
S821	1-771-349-21	SWITCH, KEYBOARD (PLAY MODE)		C609	1-128-552-51	ELECT 47UF 20.00% 63V	
S821	1-771-349-41	SWITCH, KEYBOARD (PLAY MODE)		C610	1-126-964-11	ELECT 10UF 20.00% 50V	
		*****		C611	1-126-767-11	ELECT 1000UF 20.00% 16V	
				C613	1-126-935-11	ELECT 470UF 20.00% 6.3V	
				C616	1-161-494-00	CERAMIC 0.022UF 25V	
				C619	1-104-665-11	ELECT 100UF 20.00% 10V	
				△C620	1-113-924-11	CERAMIC 0.0047UF 20.00% 250V	
				C622	1-164-159-11	CERAMIC 0.1UF 50V	
		< CONNECTOR >					
				CN301	1-784-798-11	CONNECTOR, FFC 37P	
				CN302	1-568-838-11	CONNECTOR, FFC 21P	
				CN311	1-573-911-11	PIN, CONNECTOR 13P	
				CN351	1-506-468-11	PIN, CONNECTOR 3P (CE375)	
				CN603	1-792-131-11	LEAD (WITH CONNECTOR)	
		< DIODE >					
				D353	8-719-991-33	DIODE 1SS133T-77	
				D601	8-719-024-99	DIODE 11ES2-NTA2B	
				D602	8-719-024-99	DIODE 11ES2-NTA2B	
				D603	8-719-024-99	DIODE 11ES2-NTA2B	
				D604	8-719-024-99	DIODE 11ES2-NTA2B	

<p>The components identified by mark △ or dotted line with mark △ are critical for safety. Replace only with part number specified.</p>	<p>Les composants identifiés par une marque △ sont critiques pour la sécurité. Ne les remplacer que par une pièce portant le numéro spécifié.</p>
---	---

MAIN

Ref. No.	Part No.	Description	Remark
D605	8-719-024-99	DIODE 11ES2-NTA2B	
D606	8-719-110-08	DIODE RD8.2ESB2	
D607	8-719-991-33	DIODE 1SS133T-77	
D608	8-719-109-85	DIODE RD5.1ESB2	
D609	8-719-991-33	DIODE 1SS133T-77	
D610	8-719-983-79	DIODE MTZJ-T-72-27D	
< GROUND TERMINAL BOARD >			
EB601	1-537-770-21	TERMINAL BOARD, GROUND	
< IC >			
IC301	8-752-919-66	IC CXP82532-013Q	
IC303	8-749-921-12	IC GP1F32T	
IC350	8-759-145-58	IC BA4558	
IC351	8-759-167-88	IC NJM4565D (CE375)	
IC601	8-759-039-69	IC UPC7805AHF	
IC602	8-749-011-78	IC BA17807T	
IC603	8-759-165-82	IC PST600E-T	
< JACK >			
J301	1-785-868-11	JACK, PIN 2P	
< COIL >			
L601	1-412-473-21	INDUCTOR 0UH	
L602	1-414-151-21	INDUCTOR 470UH	
< TRANSISTOR >			
Q301	8-729-119-78	TRANSISTOR 2SC2785-HFE	
Q307	8-729-029-56	TRANSISTOR DTA144ESA-TP	
Q352	8-729-029-56	TRANSISTOR DTA144ESA-TP	
Q353	8-729-029-56	TRANSISTOR DTA144ESA-TP	
Q356	8-729-029-56	TRANSISTOR DTA144ESA-TP	
Q402	8-729-141-26	TRANSISTOR 2SC3622A-LK	
Q405	8-729-141-26	TRANSISTOR 2SC3622A-LK	
Q502	8-729-141-26	TRANSISTOR 2SC3622A-LK	
Q505	8-729-141-26	TRANSISTOR 2SC3622A-LK	
Q601	8-729-140-97	TRANSISTOR 2SB734-34	
< RESISTOR >			
R301	1-249-429-11	CARBON 10K 5%	1/4W
R302	1-249-429-11	CARBON 10K 5%	1/4W
R304	1-249-429-11	CARBON 10K 5%	1/4W
R305	1-249-807-31	CARBON 100 5%	1/4W
R306	1-249-429-11	CARBON 10K 5%	1/4W
R307	1-247-807-31	CARBON 100 5%	1/4W
R308	1-249-441-11	CARBON 100K 5%	1/4W
R320	1-249-427-11	CARBON 6.8K 5%	1/4W F
R321	1-249-427-11	CARBON 6.8K 5%	1/4W F
R322	1-249-427-11	CARBON 6.8K 5%	1/4W F
R323	1-249-427-11	CARBON 6.8K 5%	1/4W F
R324	1-249-429-11	CARBON 10K 5%	1/4W
R325	1-249-417-11	CARBON 1K 5%	1/4W F
R326	1-249-425-11	CARBON 4.7K 5%	1/4W F
R327	1-249-425-11	CARBON 4.7K 5%	1/4W F
R329	1-249-425-11	CARBON 4.7K 5%	1/4W F
R350	1-247-807-31	CARBON 100 5%	1/4W
R351	1-247-807-31	CARBON 100 5%	1/4W

Ref. No.	Part No.	Description	Remark
R352	1-249-441-11	CARBON 100K 5%	1/4W
R353	1-249-441-11	CARBON 100K 5%	1/4W
R356	1-249-441-11	CARBON 100K 5%	1/4W
R401	1-247-895-00	CARBON 470K 5%	1/4W
R402	1-249-419-11	CARBON 1.5K 5%	1/4W F
R403	1-249-419-11	CARBON 1.5K 5%	1/4W F
R404	1-249-429-11	CARBON 10K 5%	1/4W
R405	1-249-429-11	CARBON 10K 5%	1/4W
R406	1-247-895-00	CARBON 470K 5%	1/4W
R414	1-249-409-11	CARBON 220 5%	1/4W F
R415	1-249-409-11	CARBON 220 5%	1/4W F
R419	1-249-421-11	CARBON 2.2K 5%	1/4W F
R420	1-249-409-11	CARBON 220 5%	1/4W F
R422	1-249-421-11	CARBON 2.2K 5%	1/4W F
R451	1-247-843-11	CARBON 3.3K 5%	1/4W
R452	1-249-429-11	CARBON 10K 5%	1/4W
R501	1-247-895-00	CARBON 470K 5%	1/4W
R502	1-249-419-11	CARBON 1.5K 5%	1/4W F
R503	1-249-419-11	CARBON 1.5K 5%	1/4W F
R504	1-249-429-11	CARBON 10K 5%	1/4W
R505	1-249-429-11	CARBON 10K 5%	1/4W
R506	1-247-895-00	CARBON 470K 5%	1/4W
R514	1-249-409-11	CARBON 220 5%	1/4W F
R515	1-249-409-11	CARBON 220 5%	1/4W F
R519	1-249-421-11	CARBON 2.2K 5%	1/4W F
R520	1-249-409-11	CARBON 220 5%	1/4W F
R522	1-249-421-11	CARBON 2.2K 5%	1/4W F
R551	1-247-843-11	CARBON 3.3K 5%	1/4W
R552	1-249-429-11	CARBON 10K 5%	1/4W
R601	1-249-429-11	CARBON 10K 5%	1/4W
R602	1-249-429-11	CARBON 10K 5%	1/4W
R603	1-249-429-11	CARBON 10K 5%	1/4W
R604	1-249-429-11	CARBON 10K 5%	1/4W
R605	1-249-411-11	CARBON 330 5%	1/4W
R606	1-247-807-31	CARBON 100 5%	1/4W
R607	1-249-389-11	CARBON 4.7 5%	1/4W F
< SWITCH >			
S602	1-572-675-11	SWITCH, POWER VOLTAGE CHANGE (VOLTAGE SELECTOR)(CE375:E)	
< TRANSFORMER >			
△ T601	1-435-342-11	TRANSFORMER, POWER (CE275:US/CND,CE375:US/CND)	
△ T601	1-435-343-11	TRANSFORMER, POWER (CE275:AUS,CE375:AUS/AEP/UK/SP)	
△ T601	1-435-344-11	TRANSFORMER, POWER (CE375:E)	
< VIBRATOR >			
X301	1-579-175-11	VIBRATOR, CERAMIC	

The components identified by mark Δ or dotted line with mark Δ are critical for safety. Replace only with part number specified.	Les composants identifiés par une marque Δ sont critiques pour la sécurité. Ne les remplacer que par une pièce portant le numéro spécifié.
--	---

POWER SW

LOADING MOTOR

SENSOR

JUNCTION

Ref. No.	Part No.	Description	Remark
	1-681-141-11	POWER SW BOARD (CE275,CE375:US/CND) *****	
	1-681-141-21	POWER SW BOARD (CE375:AUS/AEP/UK/SP/E) *****	
		< CAPACITOR >	
△C601	1-113-924-11	CERAMIC 0.0047UF 20.00% 250V	
		< CONNECTOR >	
* CN601	1-580-230-31	PIN, CONNECTOR (PC BOARD) 2P	
* CN602	1-568-226-11	PIN, CONNECTOR 2P	
		< SWITCH >	
△S601	1-762-581-11	SWITCH, AC POWER PUSH (1 KEY)	

	1-676-244-11	LOADING MOTOR BOARD *****	

	1-676-245-11	SENSOR BOARD *****	
	1-676-246-11	JUNCTION BOARD *****	
		< CAPACITOR >	
C10	1-124-589-11	ELECT 47UF 20% 16V	
C11	1-161-494-00	CERAMIC 0.022UF 25V	
		< CONNECTOR >	
CN10	1-750-243-11	SOCKET, CONNECTOR 6P	
CN11	1-573-911-11	PIN, CONNECTOR 13P	
CN13	1-506-481-11	PIN, CONNECTOR 2P	
* CN14	1-568-941-11	PIN, CONNECTOR 3P	
CN15	1-784-767-11	CONNECTOR, FFC 6P	
		< DIODE >	
D10	8-749-924-18	PHOTO INTERRUPTER RPI-1391	
D11	8-749-017-45	SENSOR, PHONT RPR-220C1N	
		< IC >	
IC11	8-759-356-03	IC BA6780	
		< RESISTOR >	
R10	1-249-416-11	CARBON 820 5% 1/4W F	
R11	1-249-407-11	CARBON 150 5% 1/4W F	
R12	1-249-429-11	CARBON 10K 5% 1/4W	
R21	1-249-429-11	CARBON 10K 5% 1/4W	
R22	1-249-426-11	CARBON 5.6K 5% 1/4W	
R23	1-249-425-11	CARBON 4.7K 5% 1/4W F	
R24	1-249-430-11	CARBON 12K 5% 1/4W	
R25	1-249-382-11	CARBON 1.2 5% 1/6W F	
R26	1-249-382-11	CARBON 1.2 5% 1/6W F	

Ref. No.	Part No.	Description	Remark
		< SWITCH >	
S11	1-771-836-11	SWITCH, LEVER (SLIDE) *****	
		MISCELLANEOUS *****	
△9	1-575-651-21	CORD, POWER (CE375:AEP/UK/SP)	
△9	1-696-845-11	CORD, POWER (CE275:AUS,CE375:AUS)	
△9	1-777-071-41	CORD, POWER (CE375:AEP/UK/SP)	
△9	1-783-528-21	CORD, POWER (TRACKING)(CE375:E)	
△9	1-783-531-31	CORD, POWER (CE275:US/CND,CE375US/CND)	
△T601	1-435-342-11	TRANSFORMER, POWER (CE275:US/CND,CE375:US/CND)	
△T601	1-435-343-11	TRANSFORMER, POWER (CE275:AUS,CE375:AUS/AEP/UK/SP)	
△T601	1-435-344-11	TRANSFORMER, POWER (CE375:E)	
60	1-792-486-11	WIRE (FLAT TYPE)(37 CORE)	
FL801	1-517-946-21	INDICATOR TUBE, FLUORESCENT	
111	1-791-930-11	WIRE (FLAT TYPE)(6 CORE)	
116	1-757-648-11	WIRE (FLAT TYPE)(21 CORE)	
160	1-418-746-11	ENCODER, ROTARY	
△201	1-796-033-11	LIGHT PICK UP (PXR-104X)	
202	1-782-817-11	WIRE (FLAT TYPE)(16 CORE)	

		ACCESSORIES & PACKING MATERIALS *****	
	1-418-857-11	COMMANDER, STANDARD (RM-DC345) (CE375:AUS/AEP/UK/SP/E)	
	1-476-132-11	REMOTE COMMANDER (RM-DC355) (CE375:US/CND)	
	1-558-271-11	CORD, CONNECTION	
	4-233-300-11	MANUAL, INSTRUCTION (ENGLISH) (CE275:US,CE375:US)	
	4-233-300-21	MANUAL, INSTRUCTION (ENGLISH, FRENCH) (CE275:CND,CE375:CND)	
	4-233-300-31	MANUAL, INSTRUCTION (ENGLISH, FRENCH, GERMAN, SPANISH, DUTCH, SWEDISH, ITALIAN, PORTUGUESE) (CE375:AEP)	
	4-233-300-51	MANUAL, INSTRUCTION (ENGLISH, FINNISH, PORTUGUESE, RUSSIAN) (CE375:SP,CE375:E)	
	4-233-300-61	MANUAL, INSTRUCTION (ENGLISH) (CE275:AUS,CE375:AUS/UK)	
	4-234-873-01	COVER, BATTERY(RM-DC345) (CE375:AUS/AEP/UK/SP/E)	
	4-981-643-01	COVER, BATTERY(RM-DC355) (CE375:US/CND)	

The components identified by mark △ or dotted line with mark △ are critical for safety. Replace only with part number specified.	Les composants identifiés par une marque △ sont critiques pour la sécurité. Ne les remplacer que par une pièce portant le numéro spécifié.
--	--

