

CDP-XB920/XB920E

SERVICE MANUAL

AEP Model
CDP-XB920

UK Model
E Model
CDP-XB920E



Photo : CDP-XB920

Model Name Using Similar Mechanism	CDP-XE900/XE900E
CD Mechanism Type	CDM36C-14D
Base Unit Type	BU-14D
Optical Pick-up Type	KSS-213B/K-N

SPECIFICATIONS

Compact disc player

Laser	Semiconductor laser ($\lambda = 780 \text{ nm}$) Emission duration: continuous
Laser output	Max 44.6 μW * * This output is the value measured at a distance of 200 mm from the objective lens surface on the Optical Pick-up block with 7 mm aperture.

Frequency response	2 Hz to 20 kHz $\pm 0.5 \text{ dB}$
Signal-to-noise ratio	More than 113 dB
Dynamic range	More than 99 dB
Harmonic distortion	Less than 0.0025%
Channel separation	More than 105 dB

Outputs

	Jack type	Maximum output level	Load impedance
LINE OUT	Phono jacks	2 V (at 50 kilohms)	Over 50 kilohms
DIGITAL OUT (OPTICAL)	Optical output connector	-18 dBm	Wave length: 660nm
DIGITAL OUT (COAXIAL)	Coaxial output connector	0.5 Vp-p (at 75 ohms)	75 ohms
PHONES (only for CDP-XB920, CDP-XB820 and CDP-XB720)	Stereo phone jack	10 mW	32 ohms

General

Power requirements	220 V - 230 V AC, 50/60 Hz
Power consumption	15W
Dimensions (approx.) (w/h/d)	430 x 115 x 290 mm (17 x 4 5/8 x 11 1/2 in.) incl. projecting parts
Mass (approx.)	5.5 kg (12 lbs 2 oz)

Supplied accessories

Audio cord (2 phono plugs-2 phono plugs) (1)
Remote commander (remote) (1)
Sony SUM-3 (NS) batteries (2)
Stabilizer (1)

Design and specifications are subject to change without notice.

COMPACT DISC PLAYER

SONY®



TABLE OF CONTENTS

1. SERVICING NOTE	5
2. GENERAL	6
3. DISASSEMBLY	
3-1. Slide Rack	8
3-2. Front Panel	8
4. TEST MODE	9
5. ELECTRICAL BLOCK CHECKING	11
6. DIAGRAMS	
6-1. Circuit Boards Location	13
6-2. Block Diagram	15
6-3. Schematic Diagram — Main Section (1/2) —	17
6-4. Schematic Diagram — Main Section (2/2) —	19
6-5. Printed Wiring Board — Main Section —	21
6-6. Schematic Diagram — Display Section —	23
6-7. Printed Wiring Board — Display Section —	25
6-8. Schematic Diagram — Power section —	27
6-9. Printed Wiring Board — Power section —	29
6-10. Schematic Diagram — Servo section —	31
6-11. Printed Wiring Board — Servo section —	33
6-12. Schematic Diagram — Motor section —	35
6-13. Printed Wiring Board — Motor section —	36
6-14. IC Block Diagrams	37
6-15. IC Pin Function Description	39
7. EXPLODED VIEWS	43
8. ELECTRICAL PARTS LIST	48

CAUTION

Use of controls or adjustments or performance of procedures other than those specified herein may result in hazardous radiation exposure.

The laser component in this product is capable of emitting radiation exceeding the limit for Class 1.

CLASS 1 LASER PRODUCT
LUOKAN 1 LASERLAITE
KLASS 1 LASERAPPARAT

This appliance is classified as a CLASS 1 LASER product. The CLASS 1 LASER PRODUCT MARKING is located on the rear exterior.

CAUTION : INVISIBLE LASER RADIATION WHEN OPEN AND INTERLOCKS DEFEATED. AVOID EXPOSURE TO BEAM.
ADVARSEL : USYNLIG LASERSTRÅLING VED ÅBNING NÅR SIKKERHEDSAFBRYDERE ER UDE AF FUNKTION. UNDGÅ UDSÆTTELSE FOR STRÅLING.
VORSICHT : UNSICHTBARE LASERSTRAHLUNG, WENN ABDECKUNG GEÖFFNET UND SICHERHEITSVERRIEGELUNG ÜBERBRÜCKT. NICHT DEM STRAHL AUSSETZEN.
VARO! : AVATTAESSA JA SUOJALUKITUS OHITETTAESSA OLET ALTIINA NÄKYMÄTTÖMÄLLE LASERSÄTELYLLE. ÄLÄ KATSO SÄTEESEEN.
WARNING : OSYNLIG LASERSTRÅLING NÅR DENNA DEL ÅR ÖPPNAD OCH SPÄRREN ÅR URKOPPLAD. BETRÄKTA EJ STRÅLEN.
ADVERSEL : USYNLIG LASERSTRÅLING NÅR DEKSEL ÅPNES OG SIKKERHEDSLÅS BRYTES. UNNGÅ EKSPONERING FOR STRÅLEN.
VIGYAZAT! : A BURKOLAT NYITÁSÁKOR LÁTHATATLAN LÉZERSUGÁRVESZÉLY! KERÜLJE A BESUGÁRZÁST!

This caution label is located inside the unit.

Notes on chip component replacement

- Never reuse a disconnected chip component.
- Notice that the minus side of a tantalum capacitor may be damaged by heat.

Flexible Circuit Board Repairing

- Keep the temperature of soldering iron around 270°C during repairing.
- Do not touch the soldering iron on the same conductor of the circuit board (within 3 times).
- Be careful not to apply force on the conductor when soldering or unsoldering.

SAFETY-RELATED COMPONENT WARNING !!

COMPONENTS IDENTIFIED BY MARK \triangle OR DOTTED LINE WITH MARK \triangle ON THE SCHEMATIC DIAGRAMS AND IN THE PARTS LIST ARE CRITICAL TO SAFE OPERATION. REPLACE THESE COMPONENTS WITH SONY PARTS WHOSE PART NUMBERS APPEAR AS SHOWN IN THIS MANUAL OR IN SUPPLEMENTS PUBLISHED BY SONY.

MODEL IDENTIFICATION

— BACK PANEL —

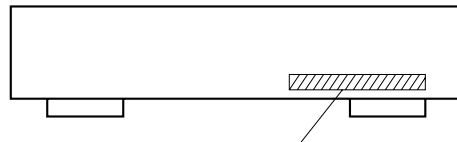

- 4-997-198-0: XB920 (AEP) model
- 4-997-198-1: XB920E (UK) model
- 4-997-198-3: XB920E (Singapore, Malaysia) model



CD-TEXT TEST DISC

This unit is able to display the test data (character information) written in the CD on its fluorescent indicator tube.

The CD-TEXT TEST DISC (TGCS-313:4-989-366-01) is used for checking the display.

To check, perform the following procedure.

Checking Method:

1. Turn ON the power, set the disc on a tray, and chuck the disc.
2. Press the  button and play back the disc.
3. The following will be displayed on the fluorescent indicator tube.
Display : 1KHZ/0 DB
4. Rotate  knob to switch the track. The text data of each track will be displayed.
For details of the displayed contents for each track, refer to “Table 1 : CD-TEXT TEST DISC Recorded Contents and Display”.

Restrictions in CD-TEXT Display

In this unit, some special characters will not be displayed properly. These will be displayed as a space or a character resembling it.

Table 1 : CD-TEXT TEST DISC Recorded Data Contents and Display (TRACKS No. 1 to 32:Normal Characters)

TRACK No.	Recorded contents	Display
1	1kHz/0dB/L&R	1 K H Z / 0 D B ----- /L&R are not displayed
2	20Hz/0dB/L&R	2 0 H Z / 0 D B ----- /L&R are not displayed
3	40Hz/0dB/L&R	4 0 H Z / 0 D B ----- /L&R are not displayed
4	100Hz/0dB/L&R	1 0 0 H Z / 0 D ----- B/L&R are not displayed
5	200Hz/0dB/L&R	2 0 0 H Z / 0 D ----- B/L&R are not displayed
6	500Hz/0dB/L&R	5 0 0 H Z / 0 D ----- B/L&R are not displayed
7	1kHz/0dB/L&R	1 K H Z / 0 D B ----- /L&R are not displayed
8	5kHz/0dB/L&R	5 K H Z / 0 D B ----- /L&R are not displayed
9	7kHz/0dB/L&R	7 K H Z / 0 D B ----- /L&R are not displayed
10	10kHz/0dB/L&R	1 0 K H Z / 0 D ----- B/L&R are not displayed
11	16kHz/0dB/L&R	1 6 K H Z / 0 D ----- B/L&R are not displayed
12	18kHz/0dB/L&R	1 8 K H Z / 0 D ----- B/L&R are not displayed
13	20kHz/0dB/L&R	2 0 K H Z / 0 D ----- B/L&R are not displayed
14	1kHz/0dB/L&R	1 K H Z / 0 D B ----- /L&R are not displayed
15	1kHz/-1dB/L&R	1 K H Z / - 1 D ----- B/L&R are not displayed
16	1kHz/-3dB/L&R	1 K H Z / - 3 D ----- B/L&R are not displayed
17	1kHz/-6dB/L&R	1 K H Z / - 6 D ----- B/L&R are not displayed
18	1kHz/-10dB/L&R	1 K H Z / - 1 0 ----- dB/L&R are not displayed
19	1kHz/-20dB/L&R	1 K H Z / - 2 0 ----- dB/L&R are not displayed
20	1kHz/-60dB/L&R	1 K H Z / - 6 0 ----- dB/L&R are not displayed
21	1kHz/-80dB/L&R	1 K H Z / - 8 0 ----- dB/L&R are not displayed
22	1kHz/-90dB/L&R	1 K H Z / - 9 0 ----- dB/L&R are not displayed
23	Infinity Zero w/o emphasis//L&R	I N F I N I T Y ----- Zero w/o emphasis//L&R are not displayed
24	Infinity Zero with emphasis//L&R	I N F I N I T Y ----- Zero with emphasis//L&R are not displayed
25	400Hz+7kHz(4:1)/0dB/L&R	4 0 0 H Z + 7 K ----- Hz(4:1)/0dB/L&R are not displayed
26	400Hz+7kHz(4:1)/-10dB/L&R	4 0 0 H Z + 7 K ----- Hz(4:1)/-10dB/L&R are not displayed
27	19kHz+20kHz(1:1)/0dB/L&R	1 9 K H Z + 2 0 ----- Hz(1:1)/0dB/L&R are not displayed
28	19kHz+20kHz(1:1)/-10dB/L&R	1 9 K H Z + 2 0 ----- Hz(1:1)/-10dB/L&R are not displayed
29	100Hz/0dB/L*	1 0 0 H Z / 0 D ----- B/L are not displayed
30	1kHz/0dB/L*	1 K H Z / 0 D B ----- /L are not displayed
31	10kHz/0dB/L*	1 0 K H Z / 0 D ----- B/L are not displayed
32	20kHz/0dB/L*	2 0 K H Z / 0 D ----- B/L are not displayed

* Other channel is infinity zero.

Table 2: CD-TEXT TEST DISC Recorded Contents and Display (TRACKS NO. 33 to 99)
(In this unit, some special characters cannot be displayed. This is no a fault.)

TRACK	Recorded contents	Display
33	100Hz/0dB/R*	1 0 0 H Z / 0 D ----- B/R are not displayed
34	1kHz/0dB/R*	1 K H Z / 0 D B ----- /R are not displayed
35	10kHz/0dB/R*	1 0 K H Z / 0 D ----- B/R are not displayed
36	20kHz/0dB/R*	2 0 K H Z / 0 D ----- B/R are not displayed
37	100Hz Squer Wave //L&R	1 0 0 H Z S Q ----- uer Wave //L&R are not displayed
38	1Hz Squer Wave //L&R	1 K H Z S Q U ----- er Wave //L&R are not displayed
39	1kHz w/emphasis/-0.37dB/L&R	1 K H Z W / E ----- mphasis/-0.37dB/L&R are not displayed
40	5kHz w/emphasis/-4.53dB/L&R	5 K H Z W / E ----- mphasis/-4.53dB/L&R are not displayed
41	16kHz w/emphasis/-9.04dB/L&R	1 6 K H Z W / ----- mphasis/-9.04dB/L&R are not displayed
42	! " # \$ % & ' (21h to 27h)1kHz 0dB L&R	' -----! " # \$ % & (21h to 27h)1kHz 0dB L&R are not displayed
43	() * + , - . / (28h to 2Fh)	() * + - / ----- , . (28h to 2Fh) are not displayed
44	0 1 2 3 4 5 6 7 (30h to 37h)	0 1 2 3 4 5 6 7 ----- (30h to 37h) are not displayed
45	8 9 : ; < = > ? (38h to 3Fh)	8 9 = ? ----- : ; < > (38h to 3Fh) are not displayed
46	@ A B C D E F G (40h to 47h)	A B C D E F G ----- @ (40h to 47h) are not displayed
47	H I J K L M N O (48h to 4Fh)	H I J K L M N O ----- (48h to 4Fh) are not displayed
48	P Q R S T U V W (50h to 57h)	P Q R S T U V W ----- (50h to 57h) are not displayed
49	X Y Z [¥] ^ _ (58h to 5Fh)	X Y Z [\] ^ _ ----- (58h to 5Fh) are not displayed
50	` a b c d e f g (60h to 67h)	` A B C D E F G ----- (60h to 67h) are not displayed
51	h i j k l m n o (68h to 6Fh)	H I J K L M N O ----- (68h to 6Fh) are not displayed
52	p q r s t u v w (70h to 77h)	P Q R S T U V W ----- (70h to 77h) are not displayed
53	x y z { } ~ ■ (78h to 7Fh)	X Y Z ----- { } ~ ■ (78h to 7Fh) are not displayed
54	▣ i ç £ ¤ ¥ ¦ § (A0h to A7h) 8859-1	----- All no displayed
55	♪ © ª » ¬ ® ¯ (A8h to AFh)	♪ © ª « ® ¯ (A8h to AFh) are not displayed
56	• ± ² ³ ´ µ ¶ • (B0h to B7h)	• ± ´ -----² ³ m ¶ • (B0h to B7h) are not displayed
57	† † ° « ¼ ½ ¾ ¿ (B8h to BFh)	¿ -----† † ° » ¼ ½ ¾ (B8h to BFh) are not displayed
58	À Á Â Ã Ä Å Æ Ç (C0h to C7h)	À Á Â Ã Ä Å -----Æ Ç (C0h to C7h) are not displayed
59	È É Ê Ë Ì Í Î (C8h to CFh)	È É Ê Ë Ì Í Î ----- (C8h to CFh) are not displayed
60	Ð Ñ Ò Ó Ô Õ Ö × (D0h to D7h)	Ñ Ò Ó Ô Õ Ö ----- (D0h to D7h) are not displayed
61	Ø Ù Ú Û Ü Ý Þ ß (D8h to DFh)	Ù Ú Û Ü Ý ----- (D8h to DFh) are not displayed
62	à á â ã ä å æ ç (E0h to E7h)	À Á Â Ã Ä Å -----æ ç (E0h to E7h) are not displayed
63	è é ê ë ì í î (E8h to EFh)	È É Ê Ë Ì Í Î ----- (E8h to EFh) are not displayed
64	ð ñ ò ó ô õ ö ÷ (F0h to F7h)	Ñ Ò Ó Ô Õ Ö ----- (F0h to F7h) are not displayed
65	ø ù ú û ü ý þ ÿ (F8h to FFh)	Ù Ú Û Ü Ý -----ø þ ÿ (F8h to FFh) are not displayed
66	No.66	NO. 66
67	No.67	NO. 67
to	to	to
99	No.99	NO. 99

* Other channel is infinity zero.

SECTION 1 SERVICING NOTE

HOW TO OPEN THE DISC TRAY WHEN POWER SWITCH TURNS OFF

*Insert a screwdriver into the aperture of the unit bottom, and
move it in the direction of arrow.*

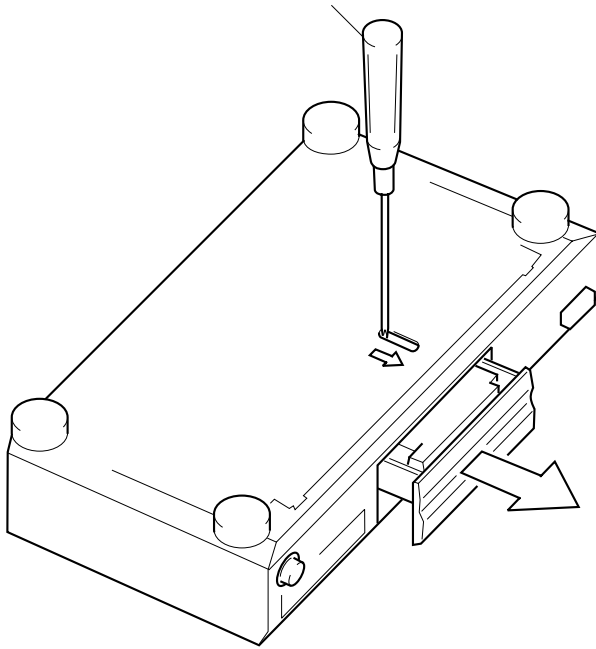

NOTES ON HANDLING THE OPTICAL PICK-UP BLOCK OR BASE UNIT

The laser diode in the optical pick-up block may suffer electrostatic breakdown because of the potential difference generated by the charged electrostatic load, etc. on clothing and the human body. During repair, pay attention to electrostatic breakdown and also use the procedure in the printed matter which is included in the repair parts.

The flexible board is easily damaged and should be handled with care.

NOTES ON LASER DIODE EMISSION CHECK

The laser beam on this model is concentrated so as to be focused on the disc reflective surface by the objective lens in the optical pick-up block. Therefore, when checking the laser diode emission, observe from more than 30 cm away from the objective lens.

LASER DIODE AND FOCUS SEARCH OPERATION CHECK

Carry out the "S curve check" in "CD section adjustment" and check that the S curve waveform is output two times.

SECTION 2 GENERAL

LOCATION AND FUNCTION OF CONTROLS [FRONT PANEL]

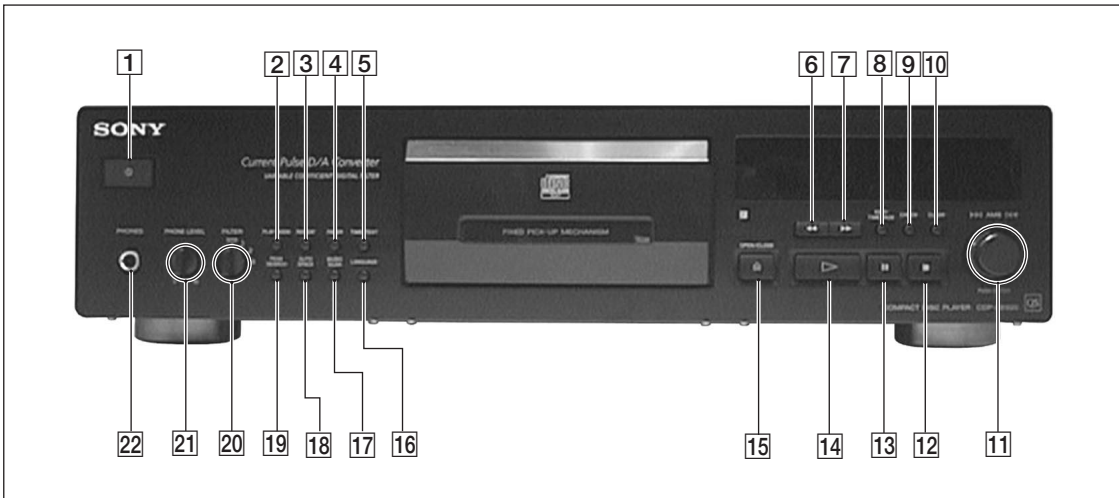

- | | |
|--------------------------------|-------------------------------|
| 1 ① (POWER) switch | 12 ■ (stop) button |
| 2 PLAY MODE button | 13 ■■ (pause) button |
| 3 REPEAT button | 14 ▷ (play) button |
| 4 FADER button | 15 ≡ OPEN/CLOSE button |
| 5 TIME/TEXT button | 16 LANGUAGE button |
| 6 ◀ button | 17 MUSIC SCAN button |
| 7 ▶ button | 18 AUTO SPACE button |
| 8 EDIT/TIME FADE button | 19 PEAK SEARCH button |
| 9 CHECK button | 20 FILTER STD switch |
| 10 CLEAR button | 21 POWER LEVEL volume |
| 11 ◀◀ AMS ▶▶ knob | 22 PHONES jack |

Basic Operations

Playing a CD

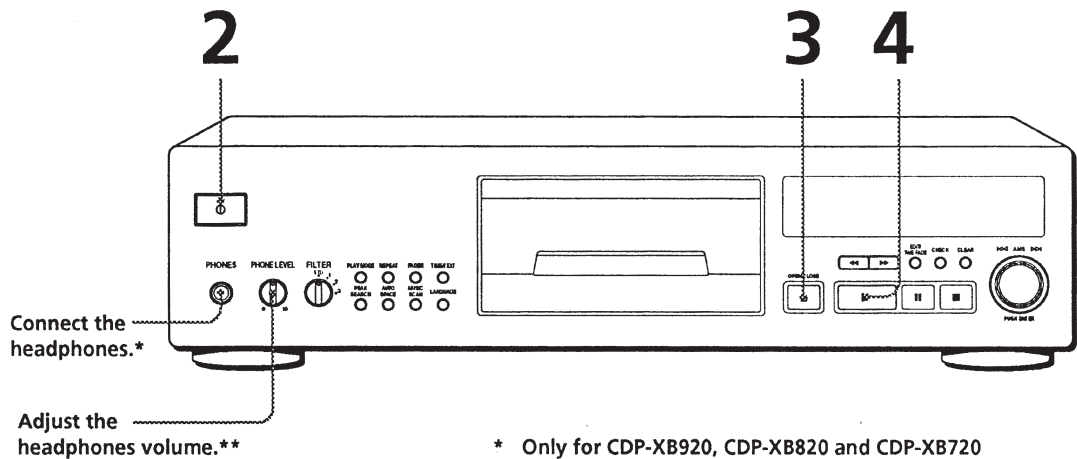

- See pages 4 – 5 for the hookup information.

If you turn on the player with a CD in the tray
You can start playing automatically from the beginning of the CD. If you connect a commercially available timer, you can start playing the CD at any time you want.

If “- NO STABI -” appears in the display (only for CDP-XB920 and CDP-XB920E)
Place the supplied stabiliser on the CD.
If you do not, this indication appears.

Note

In Step 3, do not place two or more CDs at the same time.
If you do so, you may damage the discs and/or the player.

Note

If you push the disc tray in while the power is off, the disc tray opens and closes automatically when you turn on the player again. (CDP-XB820 only)

1 Turn on the amplifier and select the CD player position.

2 Press to turn on the player.

3 Press OPEN/CLOSE, and place a CD on the tray.
• CDP-XB920 and CDP-XB920E

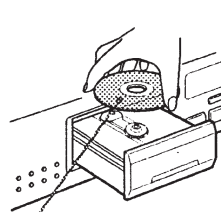

With the label side up

- CDP-XB820

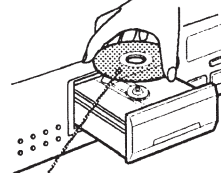

With the label side up

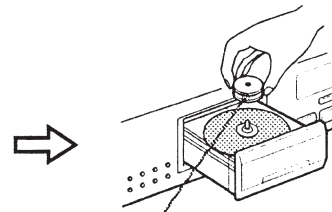

Place the supplied stabiliser on the CD with the smaller hole side facing up.

- CDP-XB720 and CDP-XB720E

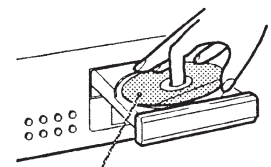

With the label side up

4 Press .
The disc tray closes and the player plays all the tracks once (Continuous Play).
Adjust the volume on the amplifier.

SECTION 3 DISASSEMBLY

Note : Follow the disassembly procedure in the numerical order given.

3-1. SLIDE RACK

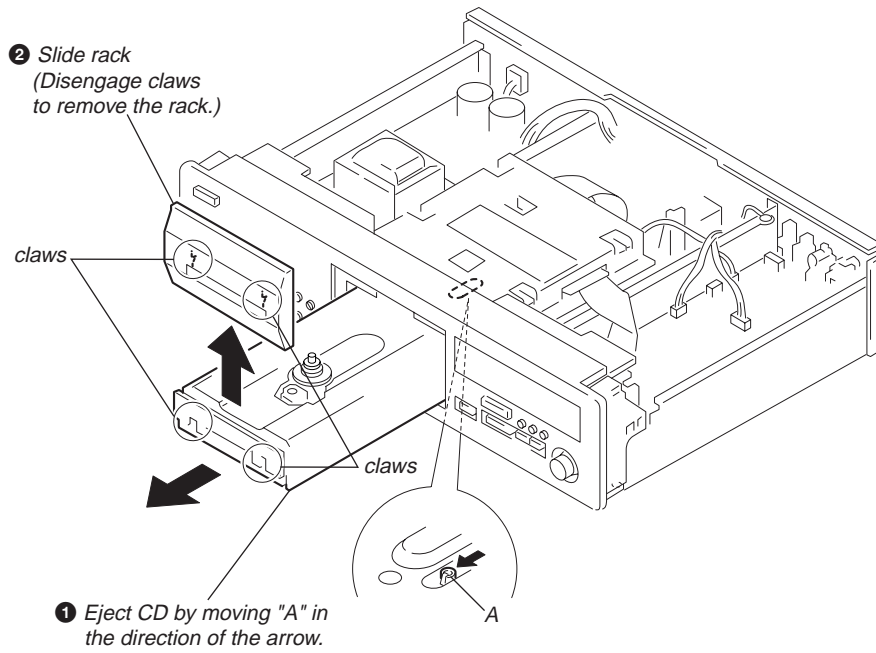

3-2. FRONT PANEL

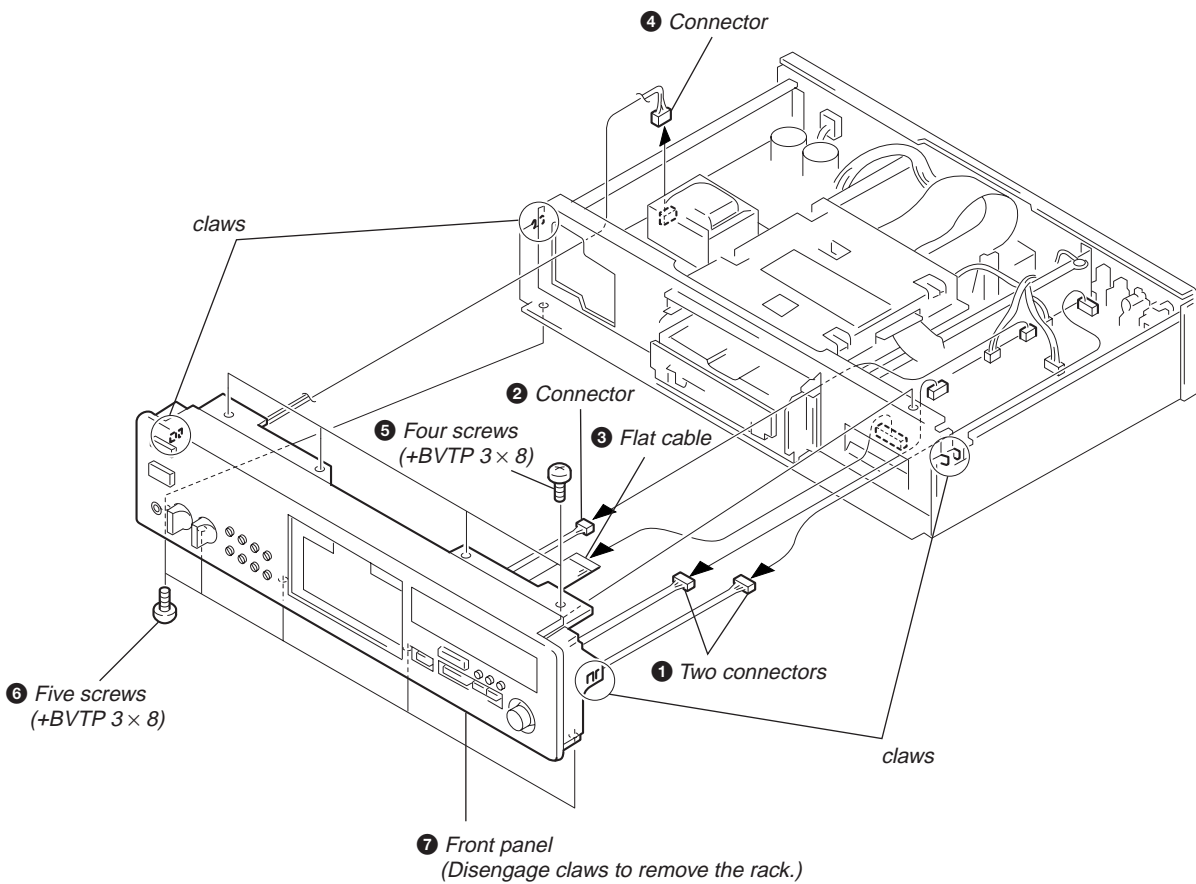

SECTION 4 TEST MODE

4-1. AF MODE

The following checks can be performed in the AF mode, which is set by connecting the TP51 (AFADJ) terminal on MAIN board to the Ground and turning on the power.

• FL tube check

After all segments light up, when the  button is pressed, the following will be displayed. (Partial lighting 1)

A B C D E F (Partial lighting 1)

When the  button is pressed, the following will be displayed. (partial lighting 2)

	2		4	
6		8		10
	12		14	
16		18		20

(Partial lighting 2)

When the  button is pressed, all will light up again.

• Key check

All buttons have corresponding button numbers. When a button is pressed, the counter will count up and display the button's number. However, the counter will only count to "18". It will not count for buttons already pressed once, but will display the button's number. (Partial lighting 3)

↑ Display of button number ↑ Display of counting
 (Partial lighting 3)

Button	Button No. Displayed	Button	Button No. Displayed
LANGUAGE	0	EDIT/	10
MUSIC SCAN	1	TIME FADE	
AUTO SPACE	2	CHECK	11
PEAK SEARCH	3	CLEAR	12
PLAY MODE	4	⏏	18
REPEAT	5	ENTER	20
FADER	6	OPEN/CLOSE	ALL lit
TIME/TEXT	7	⏏	
◀◀	8	PLAY ▷	Partial lighting 1
▶▶	9	STOP ■	Partial lighting 2

When you turn the AMS knob clockwise

JOG RIGHT

When you turn the AMS knob counter-clockwise

JOG LEFT

• Remote commander check

When the  button of the remote commander is pressed, the following will be displayed. All go off when the other buttons are pressed. (Partial lighting 4)

REMOCON PLAY
 (Partial lighting 4)

• Audio check

- Initial setting of digital filter and release of mute.
- When the TP51 (AFADJ) terminal on MAIN board is set to HIGH (VDD), emphasis turns on. When set to LOW (Ground), it turns off.

4-2. ADJ MODE

The following operations are performed in the ADJ mode, which is set by connecting the TP21 (ADJ) terminal to the Ground and turning on the power.

- During playback, there is no problem even if the GFS is continuously LOW.
- High speed search is prohibited during access.
- During playback, the gain of focus servo and spindle servo does not decrease.
- Servo related manual operations and measurement can be performed.
(For details of operations, refer to Table of Key Operations in ADJ Mode.)

4-3. CLV-S MODE

The spindle servo for playback sets into the CLV-S mode when the TP21 (ADJ) terminal is connected to Ground after turning on the power.

TABLE OF BUTTON OPERATIONS IN ADJ MODE

The jitter value display mode can be set after the all-music remaining number mode using the **TIME/TEXT** button.

The functions of the number buttons are shown in the following table.

FUNCTIONS OF NUMBER BUTTONS (With the attached remote commander)

Button	Function
1	Focus bias 8-step up (hexadecimal)
2	Middle of focus bias up/down turning point
3	Focus bias optimum point, jitter value
4	Tracking servo, sled servo off
5	Tracking gain up
6	Focus bias 8-step down (hexadecimal)
7	Immediate readjustment of focus bias
8	Focus bias 00 point
9	Tracking servo, sled servo on
10	Tracking gain down

[MAIN BOARD] — (Component Side) —

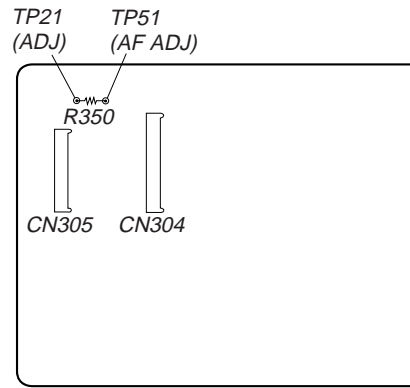

4-4. AGING MODE

This unit is equipped with an aging mode to check operations of the mechanism deck.

- When faults occur:
Aging stops, and the state when aging stopped is displayed on the fluorescent display tube.
- When no fault has occurred:
Aging is continued repeatedly.

Aging method 1

(When using the aging mode remote controller (J-2501-123-A)):

1. Press the **⓪** button and turn ON the power.
2. Set the disc on the tray.
3. Press the **AGING START** button of the aging remote controller.
4. Aging starts and the message shown in Fig. 1 is displayed on the fluorescent display tube.
5. To end, press the **⓪** button.

Aging method 2 (When no aging mode remote controller):

1. Press the **⓪** button and turn ON the power.
2. Set the disc on the tray.
3. Press the **OPEN/CLOSE** button, **■** button, and **MUSIC SCAN** button at the same time. (If these buttons are not pressed at the same time, nothing performs.)
4. Aging starts and the message shown in Fig. 1 is displayed on the fluorescent display tube.
5. To end, press the **⓪** button.

Fig.1 Message in Aging Mode

Code No.	State	Display when normal	Display when abnormal
0	Load in	AGING-0	ERROR-0
1	Access to TOC	AGING-1	ERROR-1
2	Access to last track	AGING-2	ERROR-2
3	Playback of last track (3 seconds)	Counter display	ERROR-3
4	Access to first track	AGING-4	ERROR-4
5	Playback of first track (3 seconds)	Counter display	ERROR-5
6	Load out	AGING-6	ERROR-6

SECTION 5 ELECTRICAL BLOCK CHECKING

Note:

1. CD Block is basically designed to operate without adjustment. Therefore, check each item in order given.
2. Use YEDS-18 disc (3-702-101-01) unless otherwise indicated.
3. Use an oscilloscope with more than 10MΩ impedance.
4. Clean the object lens by an applicator with neutral detergent when the signal level is low than specified value with the following checks.

S Curve Check

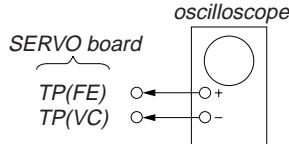

Procedure :

1. Connect oscilloscope to test point TP (FE) on SERVO board.
2. Connect between test point TP (FEI) and TP (VC) by lead wire.
3. Turn ① (power) switch on.
4. Put disc (YEDS-18) in and turn ① (power) switch on again and actuate the focus search. (actuate the focus search when disc table is moving in and out.)
5. Check the oscilloscope waveform (S-curve) is symmetrical between A and B. And confirm peak to peak level within 3 ± 1 Vp-p.

S-curve waveform

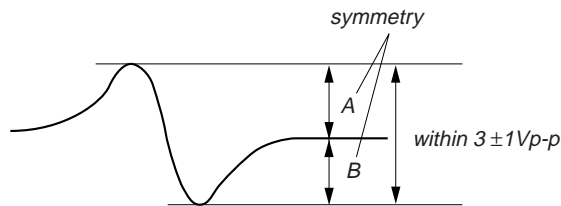

6. After check, remove the lead wire connected in step 2.

Note :

- Try to measure several times to make sure than the ratio of A : B or B : A is more than 10 : 7.
- Take sweep time as long as possible and light up the brightness to obtain best waveform.

RF Level Check

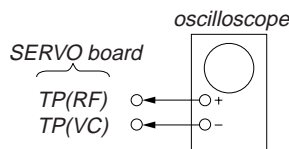

Procedure :

1. Connect oscilloscope to test point TP (RF) on SERVO board.
2. Turn ① (power) switch on.
3. Put disc (YEDS-18) in to play the number five track.
4. Confirm that oscilloscope waveform is clear and check RF signal level is correct or not.

Note: A clear RF signal waveform means that the shape “0” can be clearly distinguished at the center of the waveform.

RF signal waveform

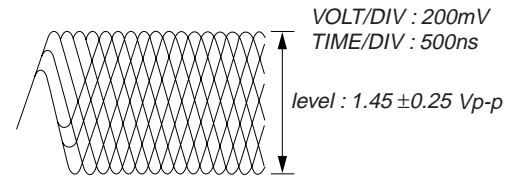

E-F Balance (1 Track Jump) Check (Without remote commander)

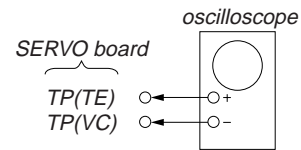

Procedure :

1. Connect oscilloscope to test point TP (TE) on SERVO board.
2. Turn ① (power) switch on.
3. Put disc (YEDS-18) in to play the number five track.
4. Press the “|| (Pause)” button. (Becomes the 1 track jump mode)
5. Check the level B of the oscilloscope's waveform and the A (DC voltage) of the center of the Traverse waveform. Confirm the following :
 $A/B \times 100 = \text{less than } \pm 22\%$

1 track jump waveform

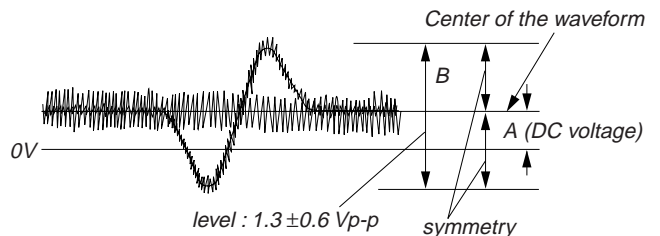

E-F Balance (Traverse) Check (With remote commander)

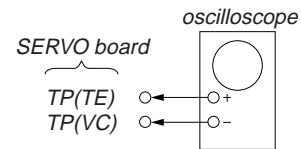

Procedure :

1. Connect oscilloscope to test point TP (TE) on SERVO board.
2. Connect the test point TP21 (ADJ) on MAIN board to the ground with a lead wire.
3. Turn the ① (power) switch on to set the ADJ mode.
4. Put disc (YEDS-18) in to play the number five track.
5. Press the “4” button. (The tracking servo and the sledding servo are turned OFF.)

6. Check the level B of the oscilloscope's waveform and the A (DC voltage) of the center of the Traverse waveform.
Confirm the following :
 $A/B \times 100 = \text{less than } \pm 22\%$

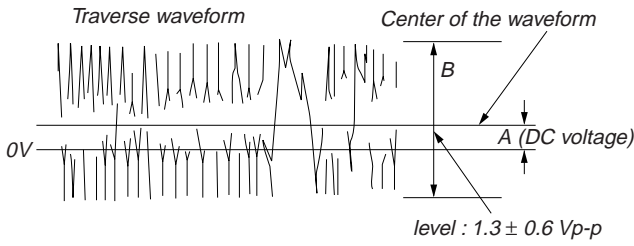

7. Press the "9" button. (The tracking servo and sledding servo are turned ON.) Confirm the C (DC voltage) is almost equal to the A (DC voltage) is step 6.

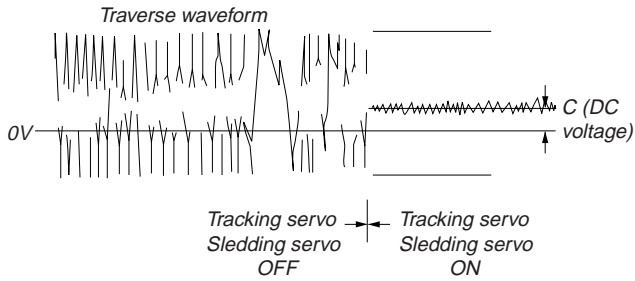

8. Disconnect the lead wire of TP21 (ADJ) connected in step 2.

[MAIN BOARD] — (Component Side) —

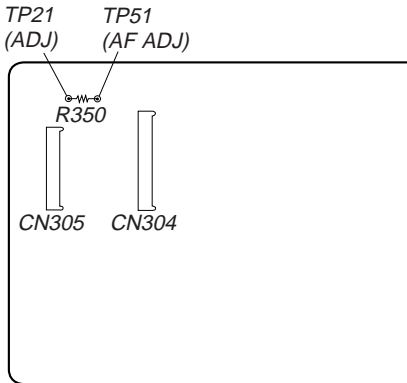

RF PLL Free-run Frequency Check

Procedure :

1. Connect frequency counter to test point TP (MNT1) with lead wire.

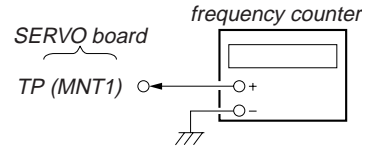

2. Turn ⓐ (power) switch on.
3. Put the disc (YEDS-18) in to play the number five track.
Confirm that reading on frequency counter is $4.3218\text{MH} \pm 30\text{kHz}$.

Adjustment Location :

[SERVO BOARD] — Side A —

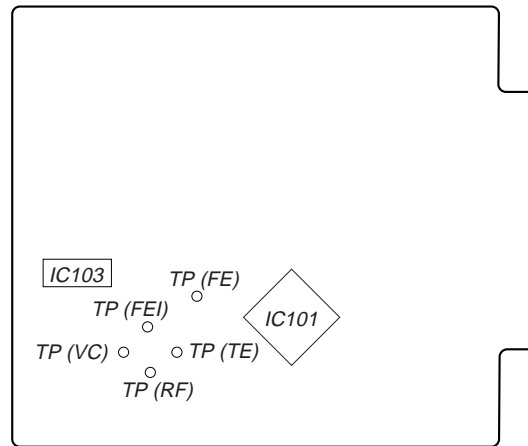

SECTION 6 DIAGRAMS

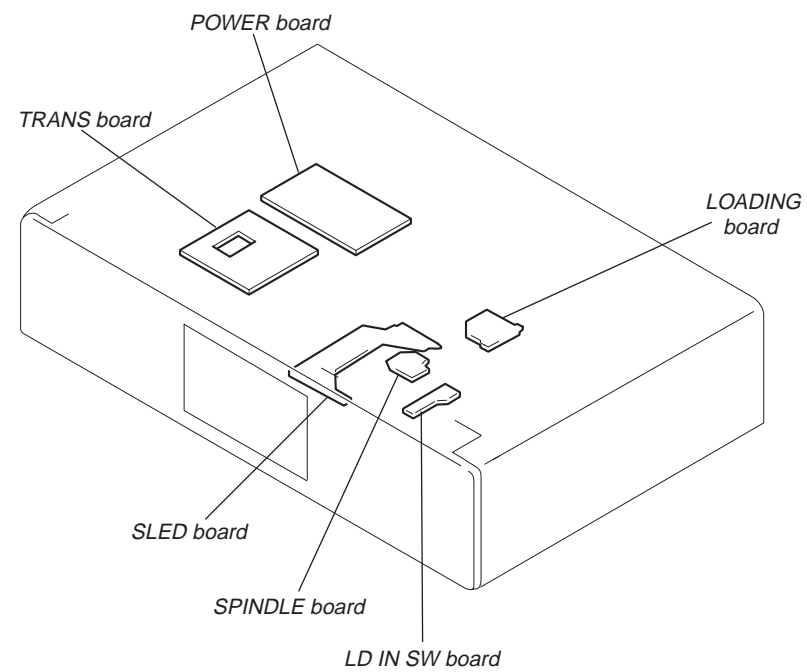
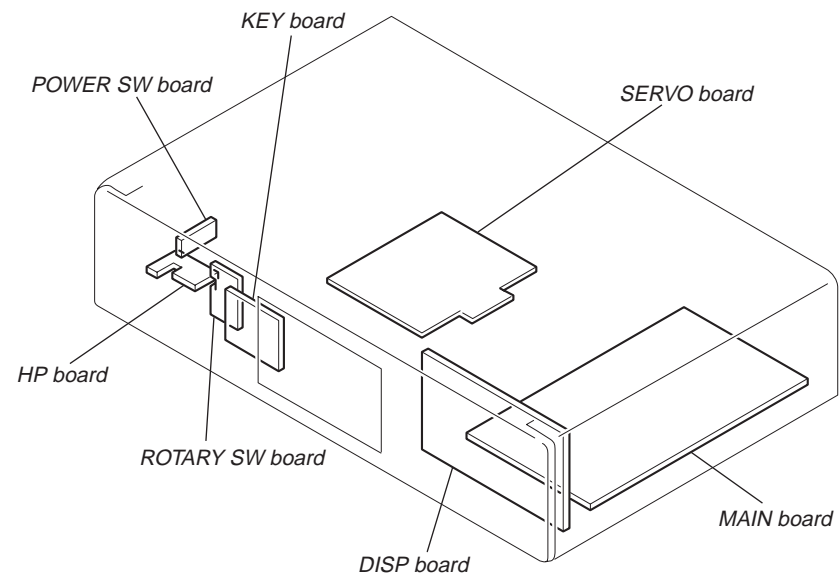

6-1. CIRCUIT BOARDS LOCATION







THIS NOTE IS COMMON FOR PRINTED WIRING BOARDS AND SCHEMATIC DIAGRAMS.
(In addition to this necessary note is printed in each block.)

For schematic diagrams.

Note:



- All capacitors are in μF unless otherwise noted. pF : $\mu\mu\text{F}$ 50 WV or less are not indicated except for electrolytics and tantalums.
- All resistors are in Ω and $1/4\text{W}$ or less unless otherwise specified.
- % : indicates tolerance.
- Δ : internal component.
-  : nonflammable resistor.
-  : fusible resistor.
-  : panel designation.

Note: The components identified by mark Δ or dotted line with mark Δ are critical for safety.
Replace only with part number specified.

-  : B+ Line.
-  : B- Line.
-  : adjustment for repair.
- Voltages and waveforms are dc with respect to ground under no-signal (detuned) conditions.
- Voltages are taken with a VOM (Input impedance $10\text{M}\Omega$). Voltage variations may be noted due to normal production tolerances.
- Waveforms are taken with a oscilloscope.
- Circled numbers refer to waveforms.
- Signal path.
-  : CD
-  : DIGITAL OUT

For printed wiring boards.

Note:

-  : parts extracted from the component side.
- \circ : Through hole.
- Δ : internal component.
-  : Pattern from the side which enables seeing.

• Waveform

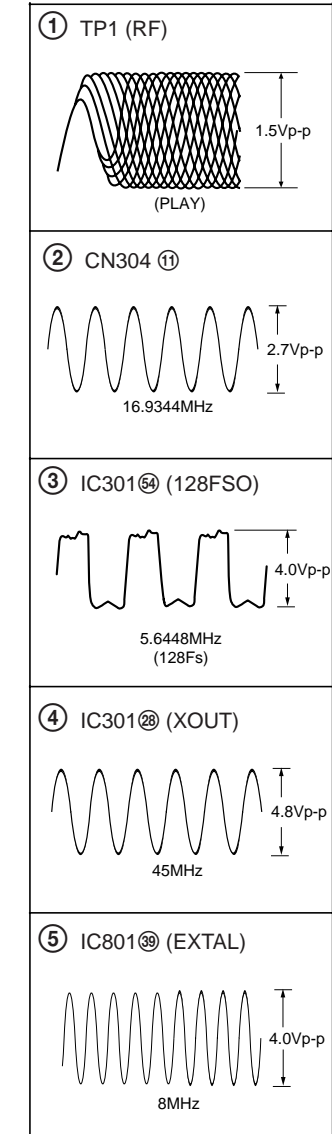

6-2. BLOCK DIAGRAM

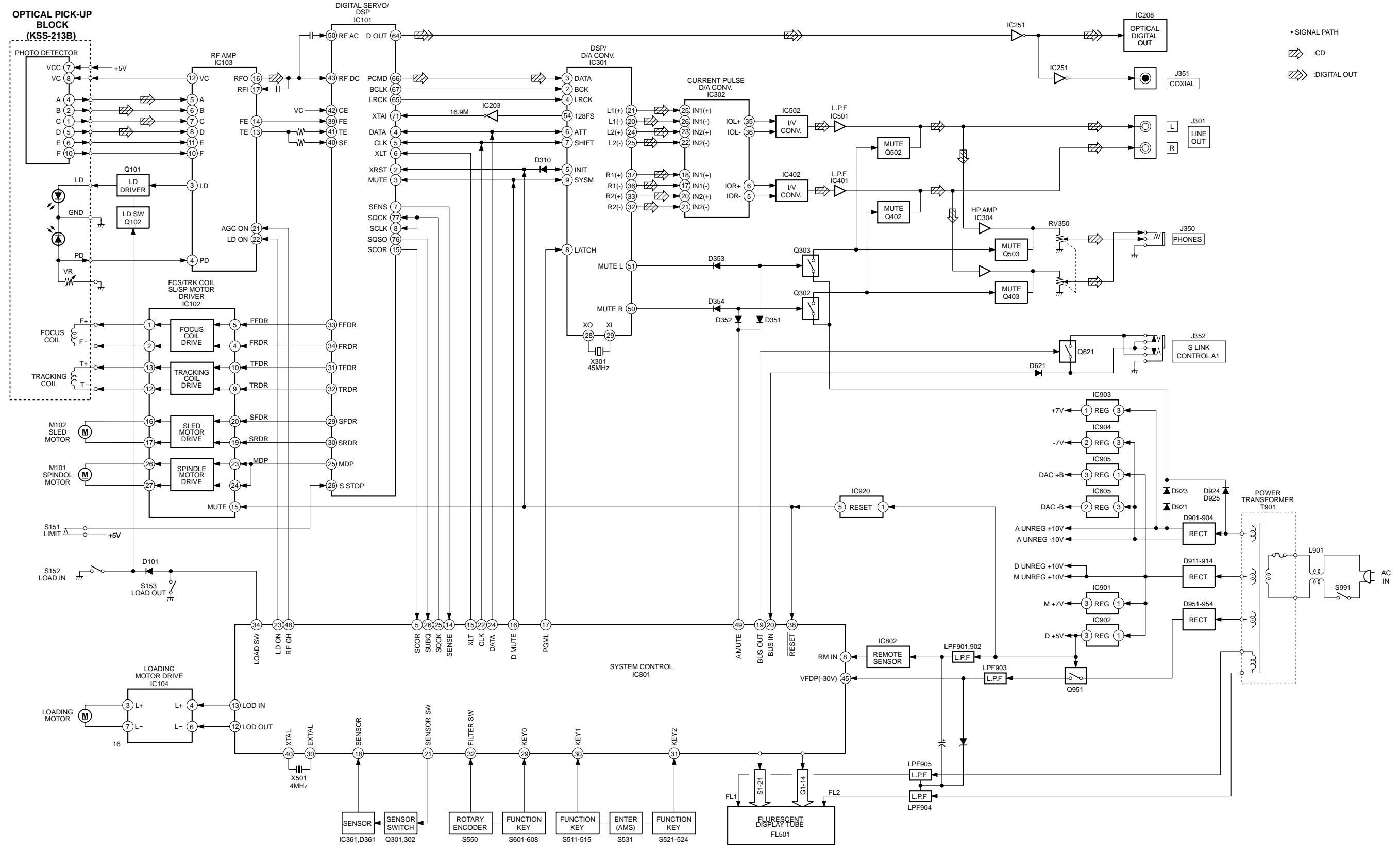

6-3. SCHEMATIC DIAGRAM – MAIN SECTION (1/2) – • See page 37 for IC Block Diagram.

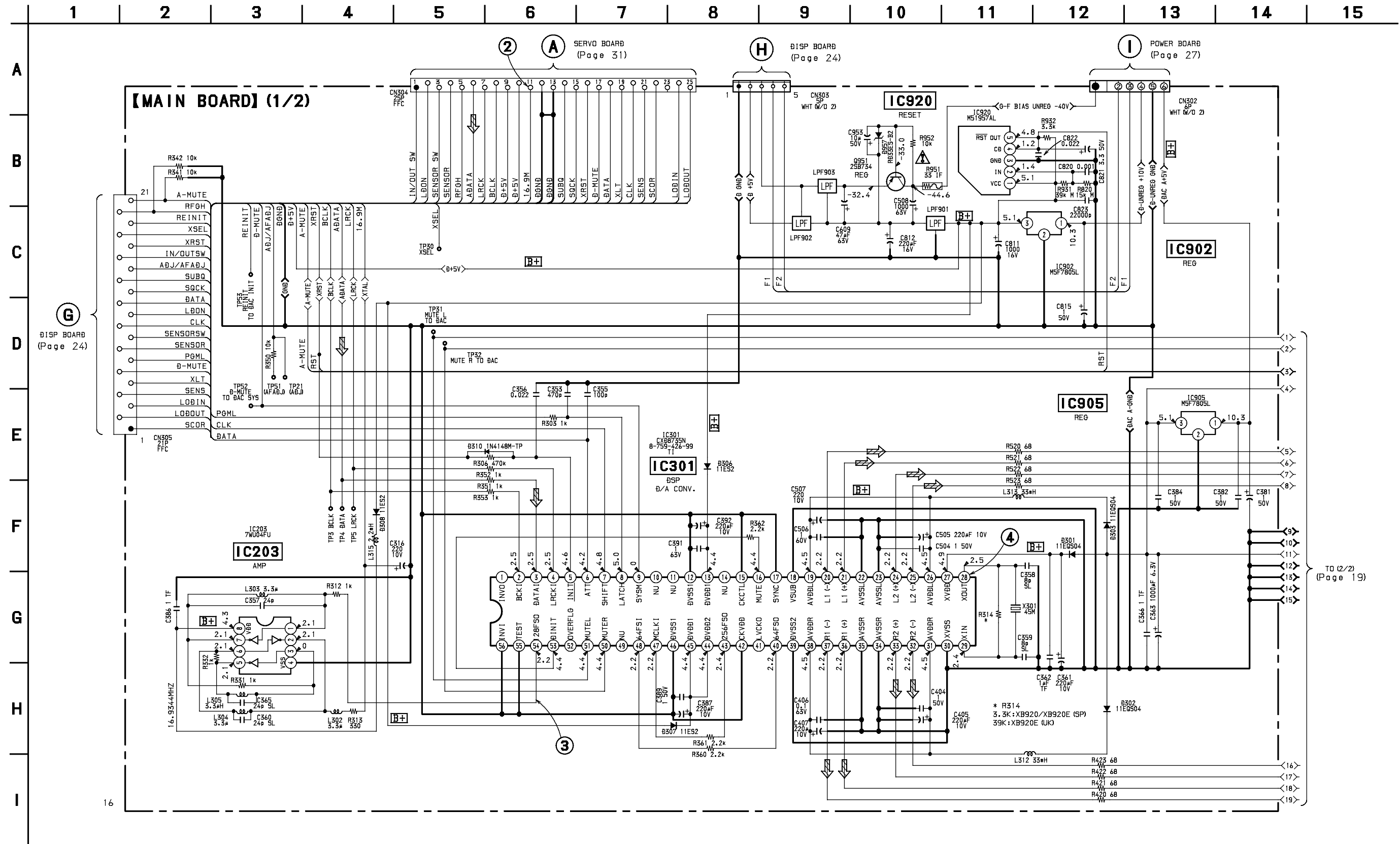

TO (2/2)
(Page 19)

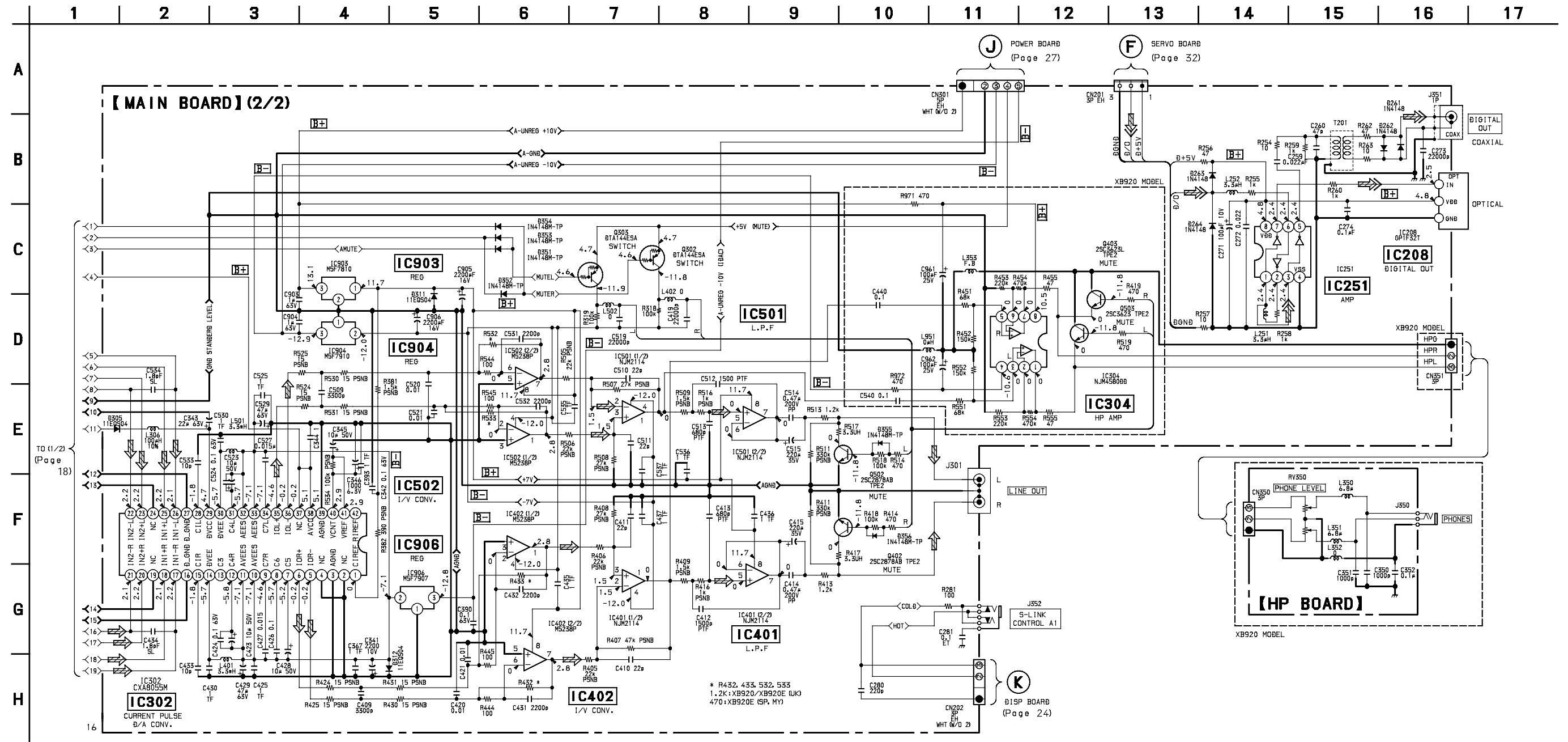

6-5. PRINTED WIRING BOARDS – MAIN SECTION – • See page 13 for Circuit Boards Location.

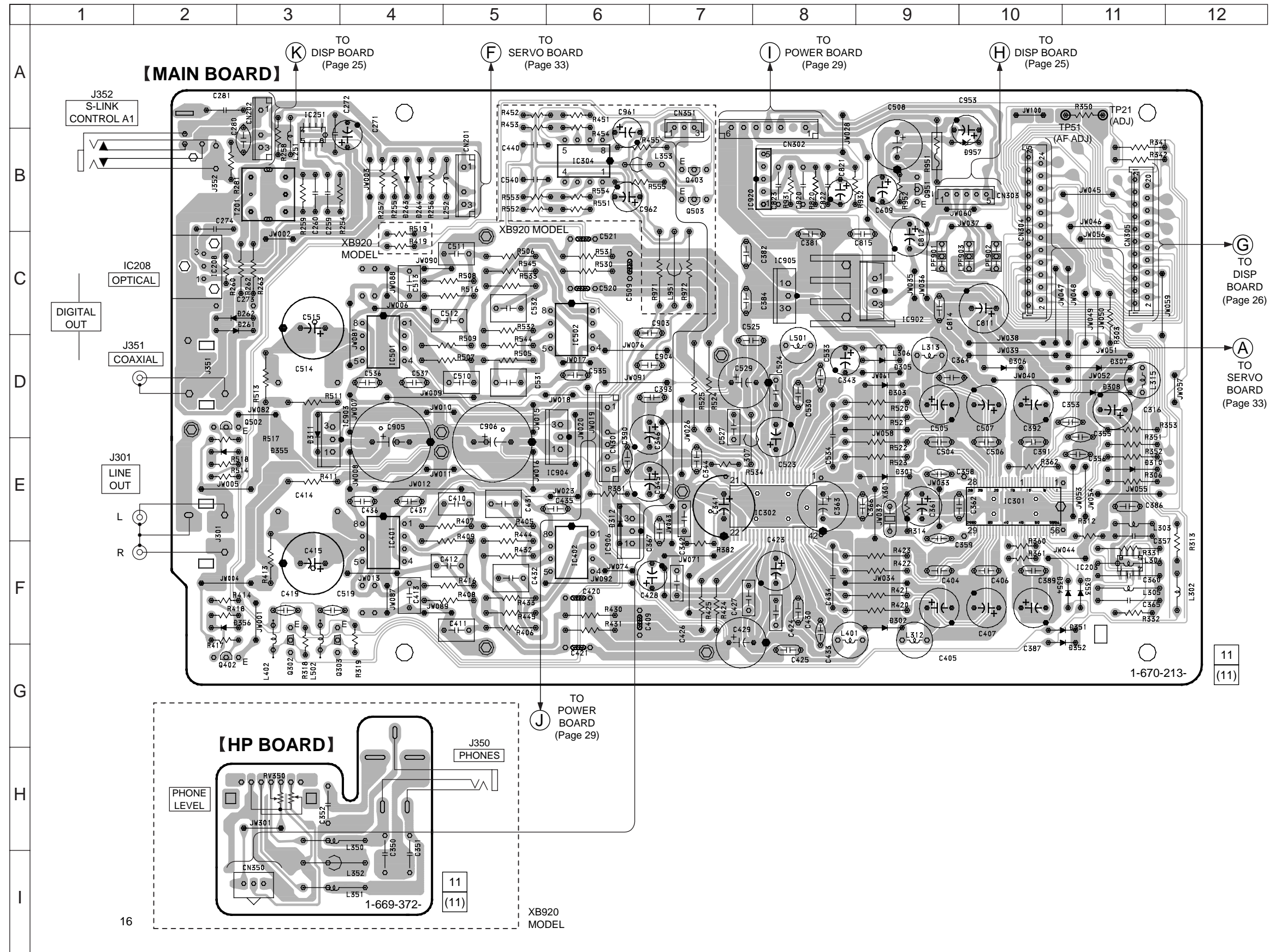

Ref. No.	Location
D261	C-3
D262	C-3
D263	B-4
D264	B-4
D301	E-9
D302	F-9
D303	D-9
D305	D-9
D306	D-10
D307	D-11
D308	D-11
D310	E-11
D311	D-3
D312	E-6
D351	F-11
D352	G-11
D353	F-11
D354	F-11
D355	E-2
D356	F-2
D957	B-10
IC203	F-11
IC208	C-2
IC251	B-3
IC301	E-10
IC302	E-8
IC304	B-6
IC401	F-4
IC402	F-6
IC501	D-4
IC502	C-6
IC902	C-9
IC903	D-3
IC904	E-6
IC905	C-8
IC906	F-6
IC920	B-8
Q302	G-3
Q303	G-3
Q402	G-2
Q403	B-7
Q502	D-2
Q503	B-7
Q951	B-9

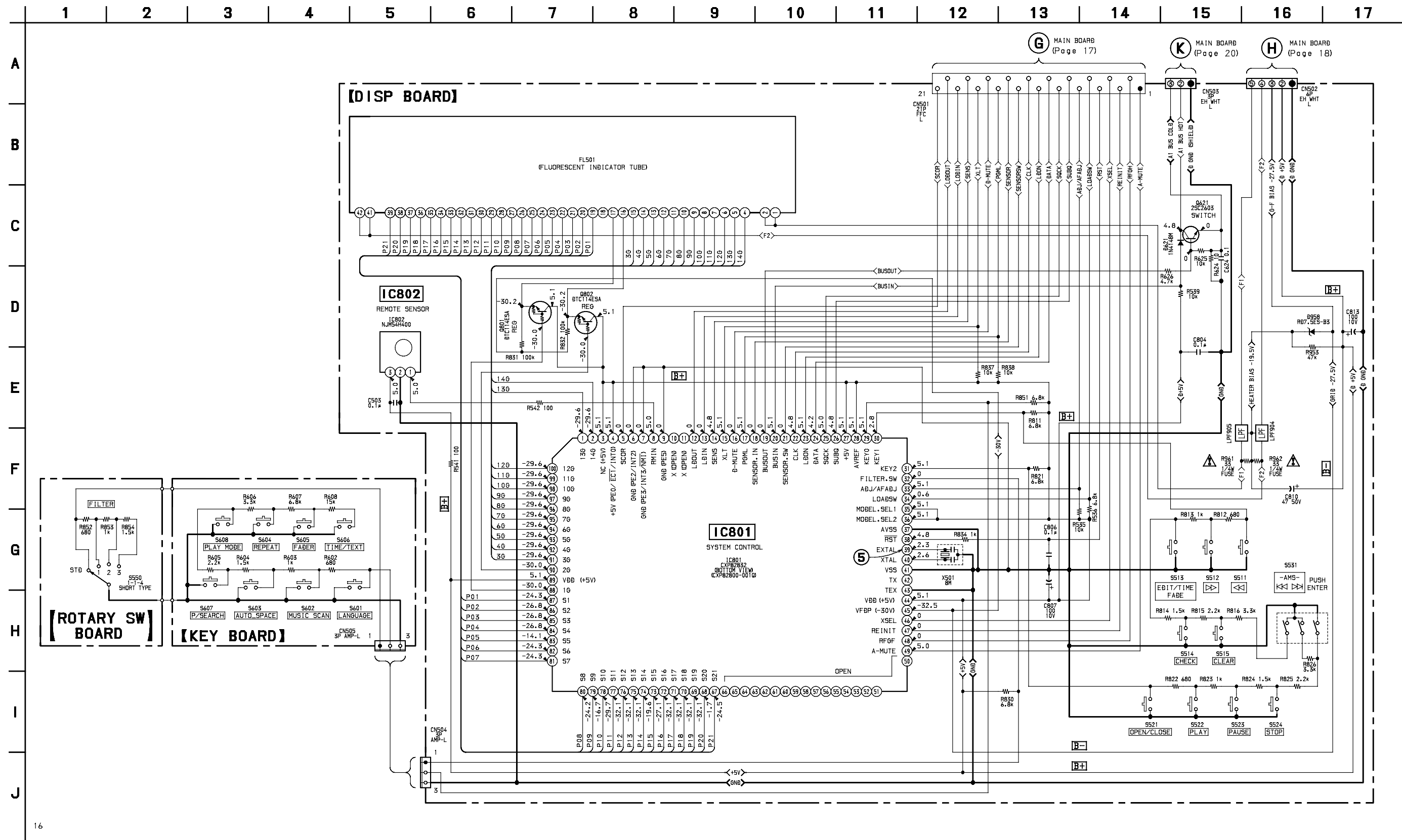

6-7. PRINTED WIRING BOARDS – DISPLAY SECTION – • See page 13 for Circuit Boards Location.

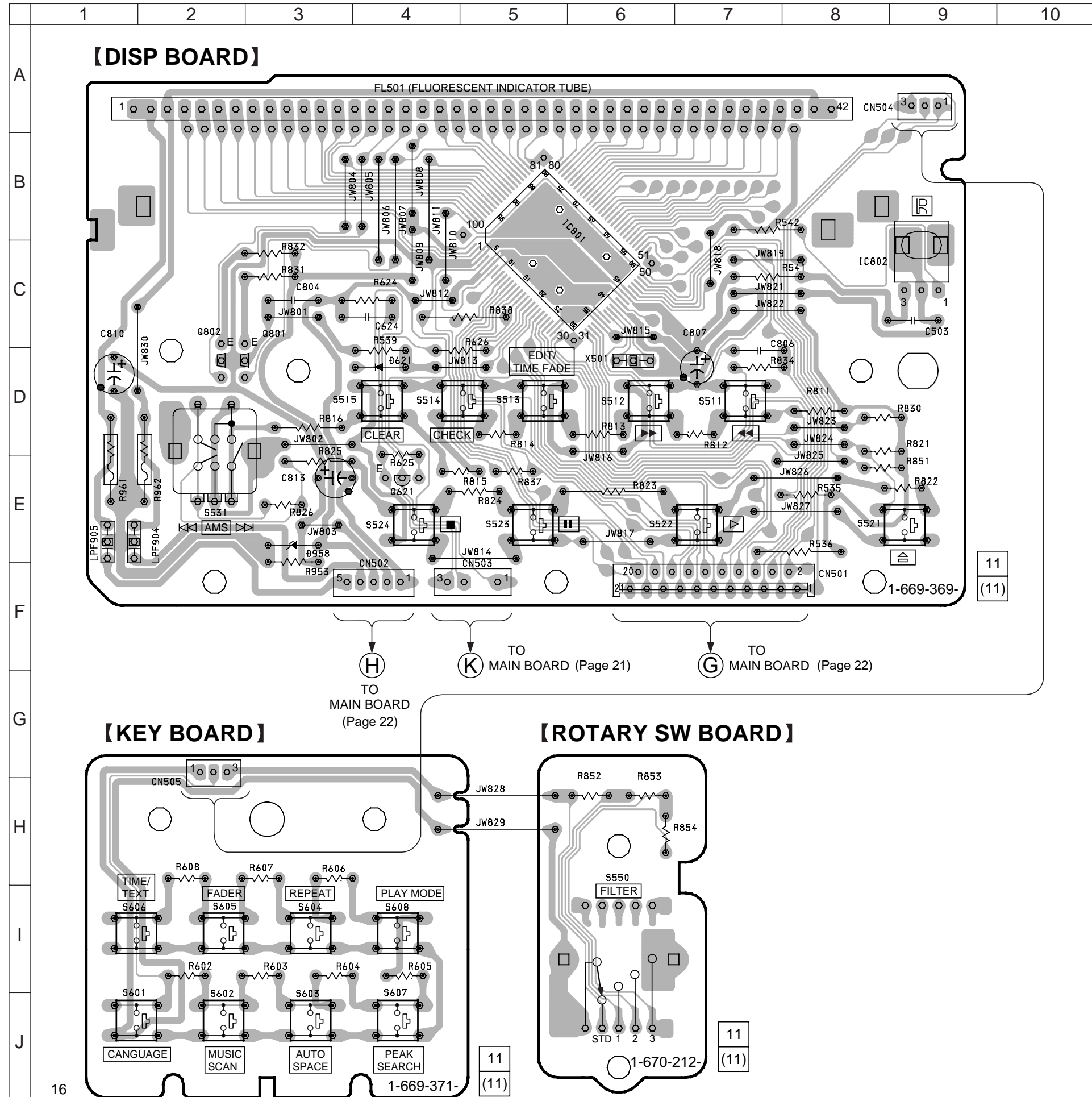

• Semiconductor Location

Ref. No.	Location
D621	D-4
D958	E-3
IC801	C-5
IC802	C-9
Q621	E-4
Q801	C-3
Q802	C-2

6-8. SCHEMATIC DIAGRAM – POWER SECTION –

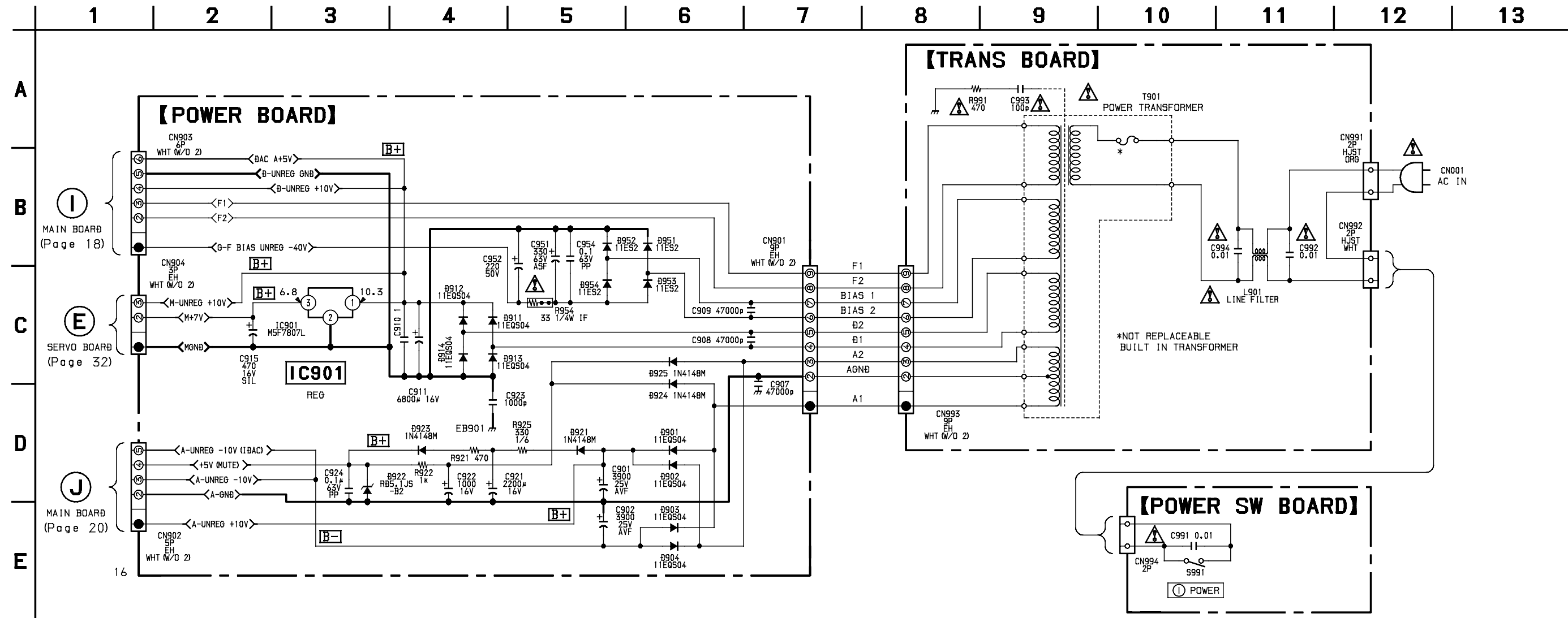

6-9. PRINTED WIRING BOARDS – POWER SECTION –

• See page 13 for Circuit Boards Location.

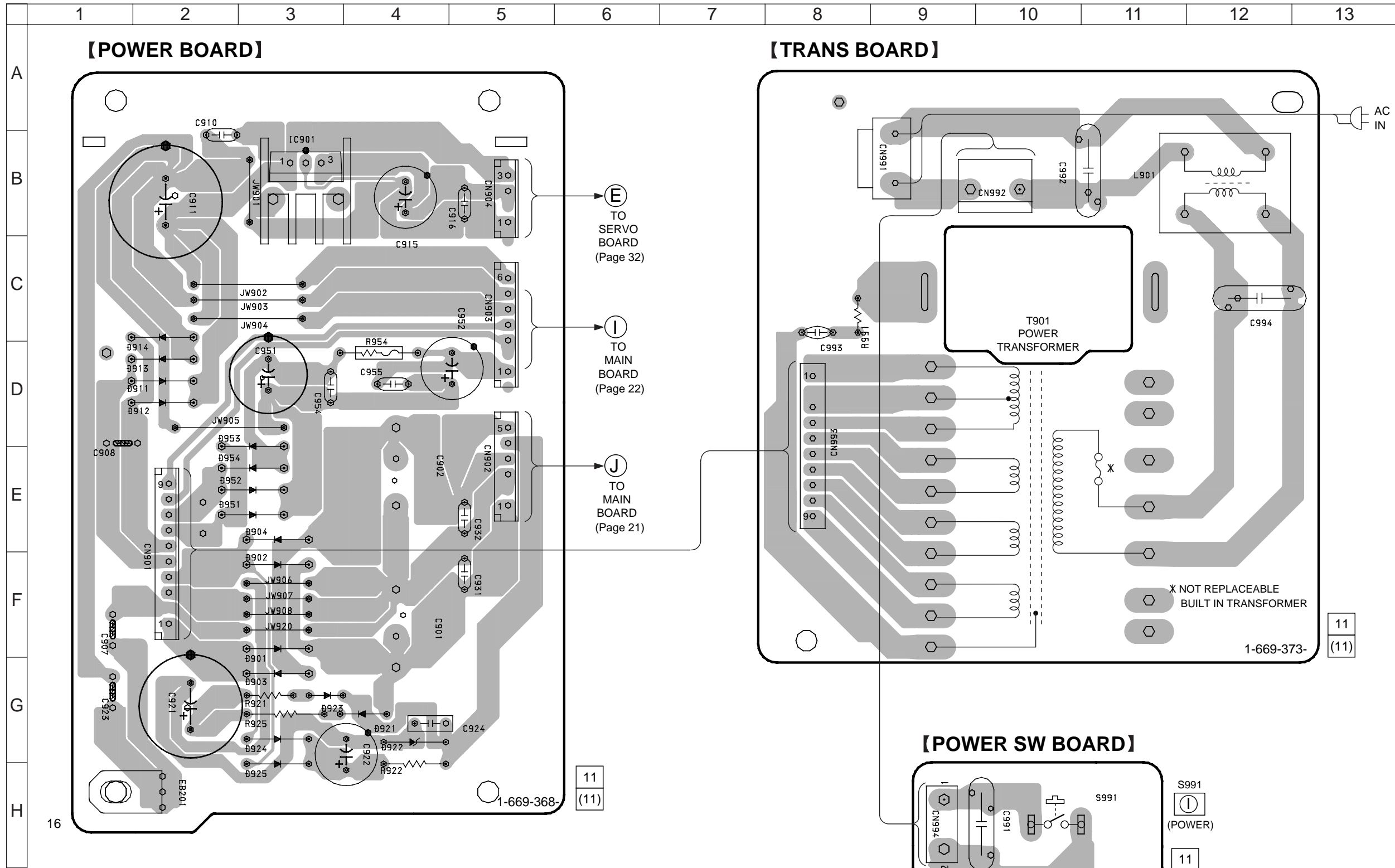

• Semiconductor Location

Ref. No.	Location
D901	F-3
D902	F-3
D903	G-3
D904	E-3
D911	D-2
D912	D-2
D913	D-2
D914	C-2
D921	G-4
D922	G-4
D923	G-3
D924	G-3
D925	H-3
D951	E-3
D952	E-3
D953	D-3
D954	E-3
IC901	B-3

16

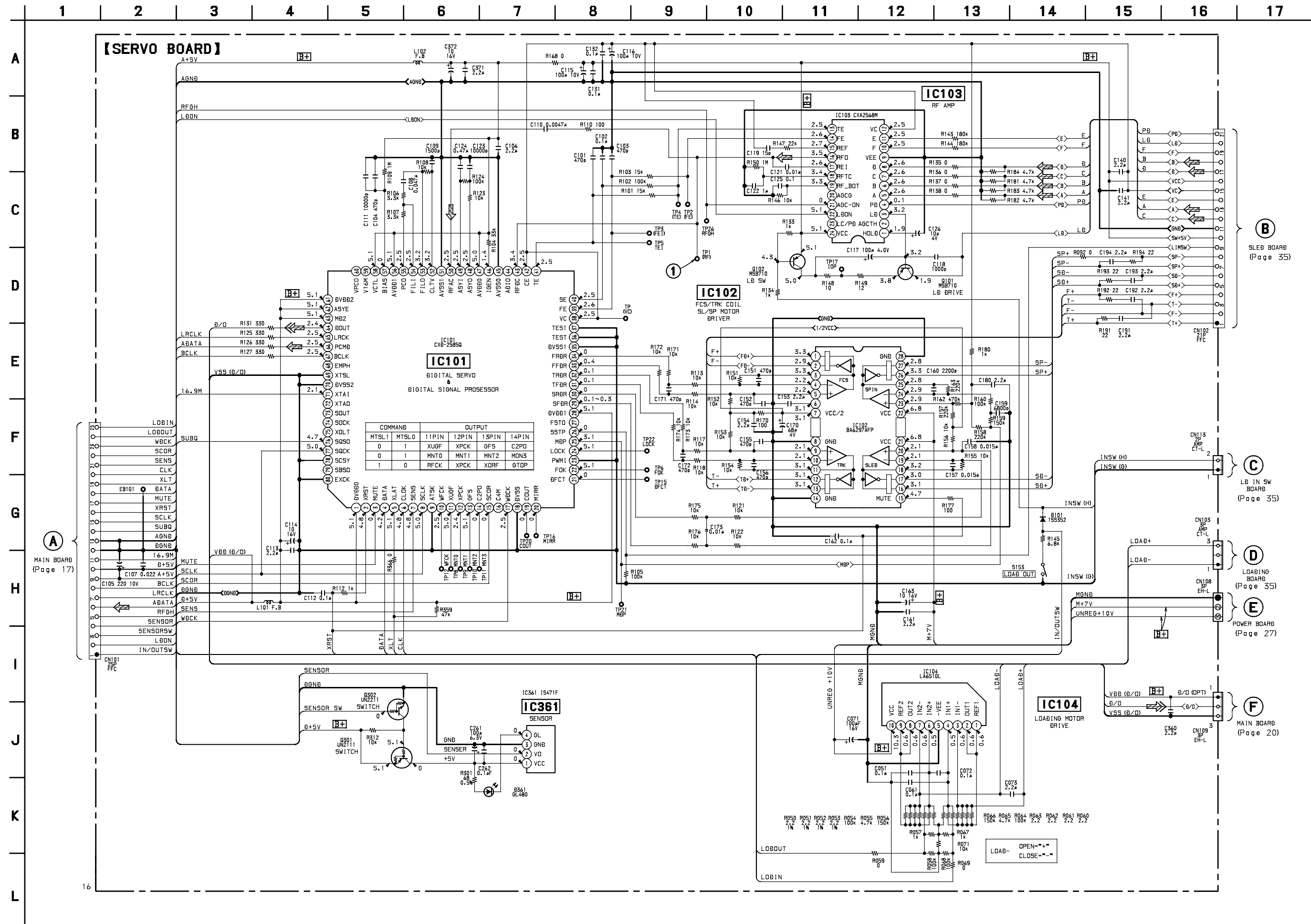

6-11. PRINTED WIRING BOARDS – SERVO SECTION – • See page 13 for Circuit Boards Location.

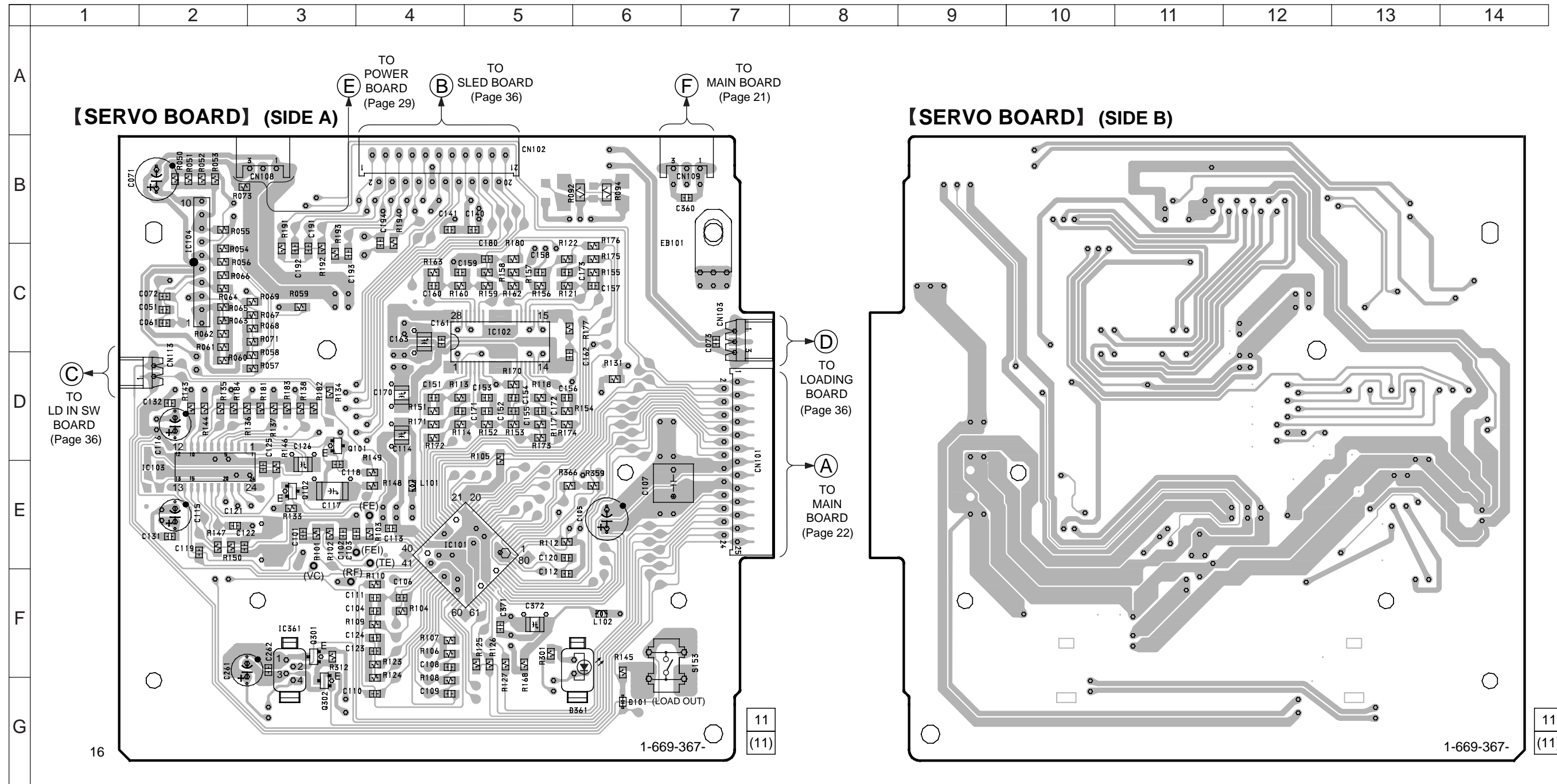

• Semiconductor Location

Ref. No.	Location
D101	G-6
D361	G-5
IC101	E-4
IC102	C-5
IC103	E-2
IC104	C-2
IC361	F-3
Q101	D-3
Q102	E-3
Q301	F-3
Q302	G-3

6-12. SCHEMATIC DIAGRAM – MOTOR SECTION –

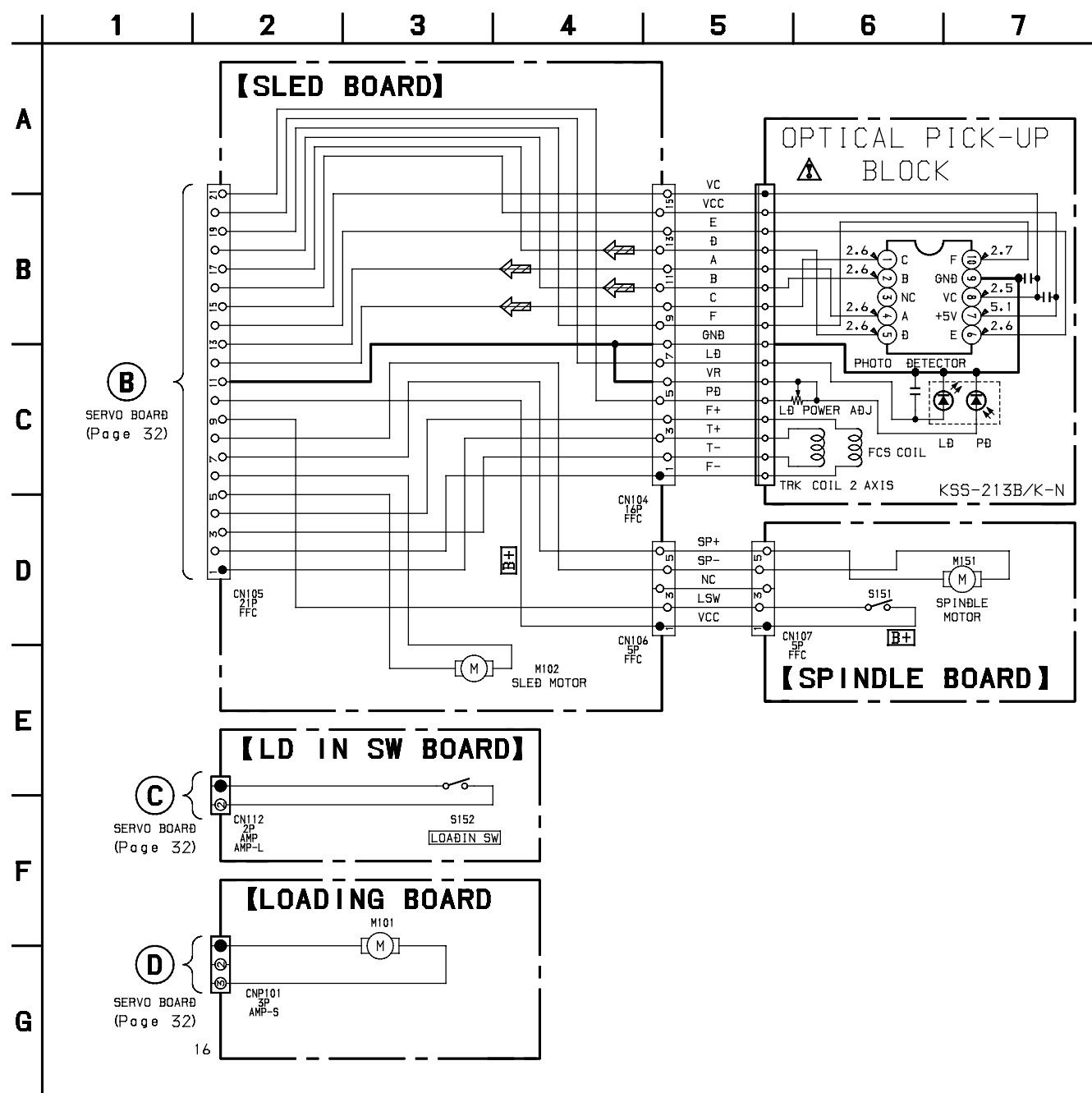

6-13. PRINTED WIRING BOARDS – MOTOR SECTION – • See page 13 for Circuit Boards Location.

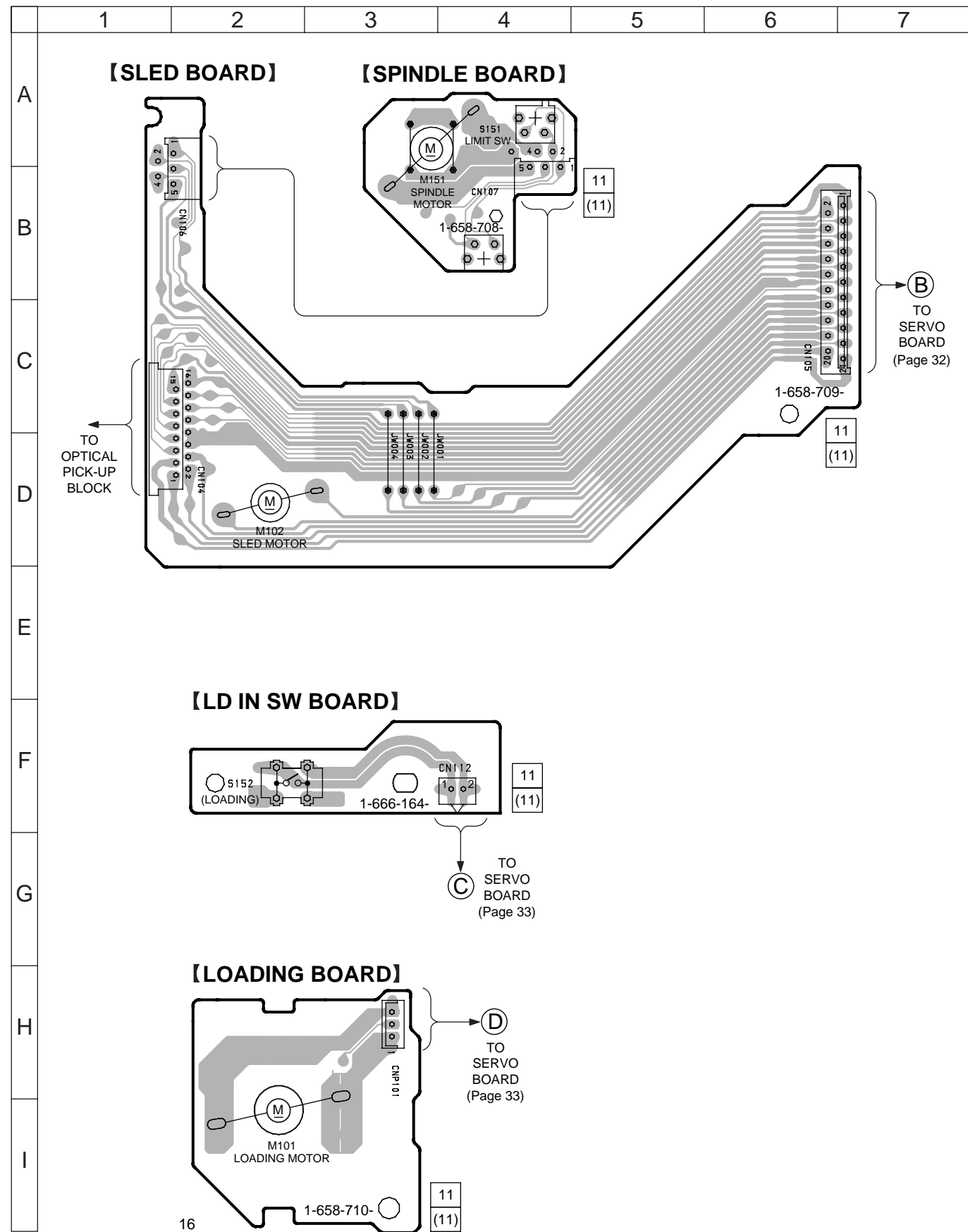

6-14. IC BLOCK DIAGRAMS

IC301 CXD8735N (MAIN BOARD)

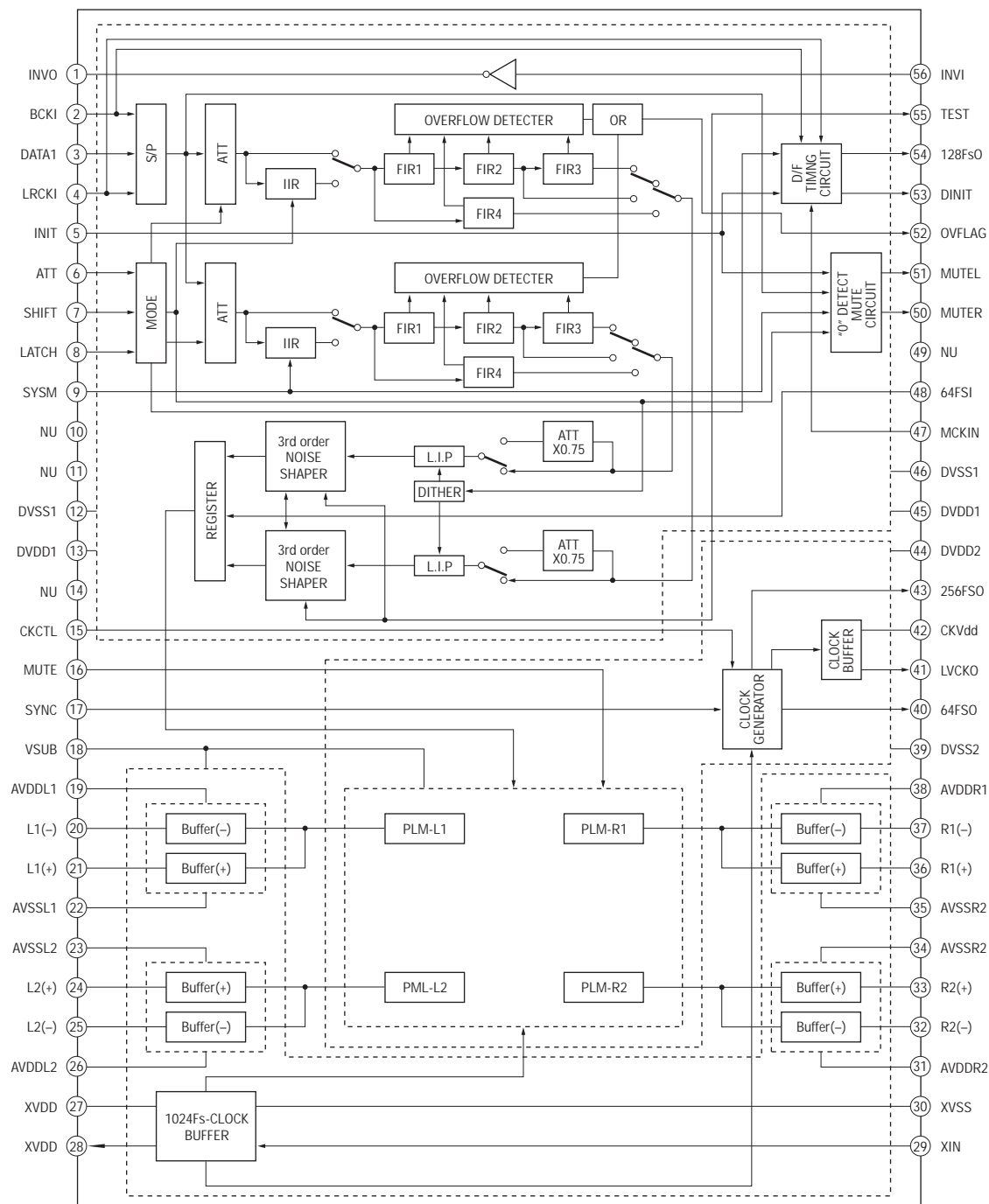

IC104 LA6510L (SERVO BOARD)

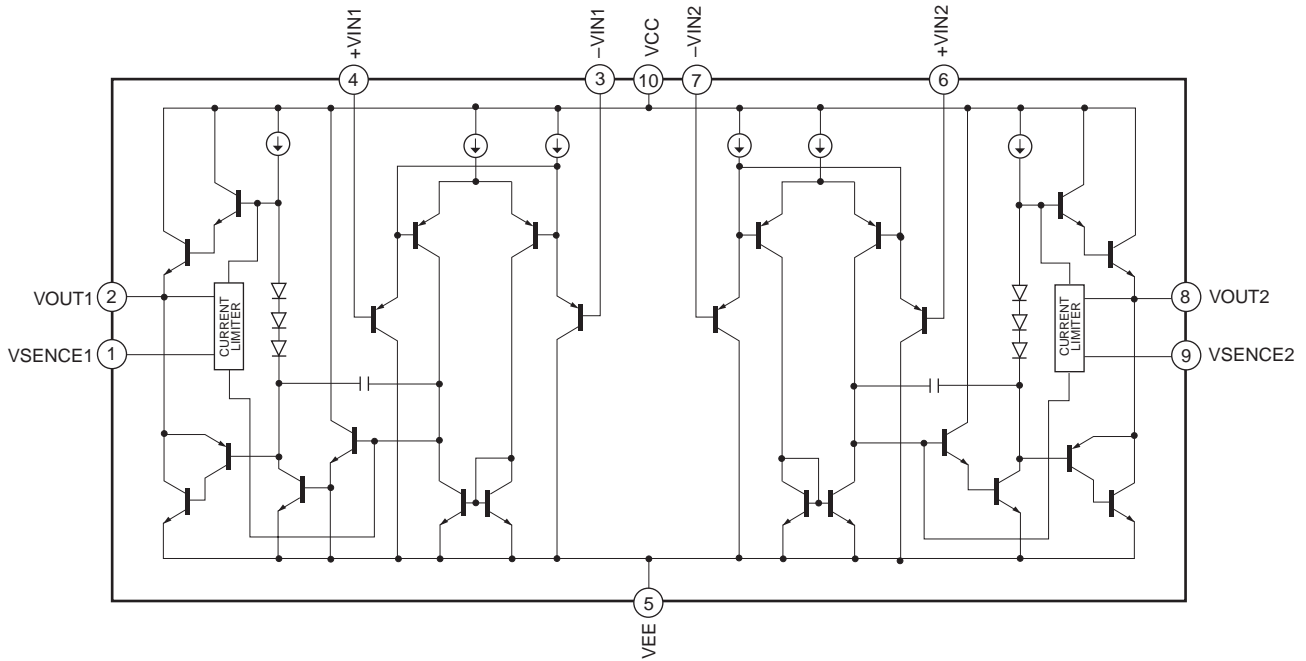

IC103 CXA2568M (SERVO BOARD)

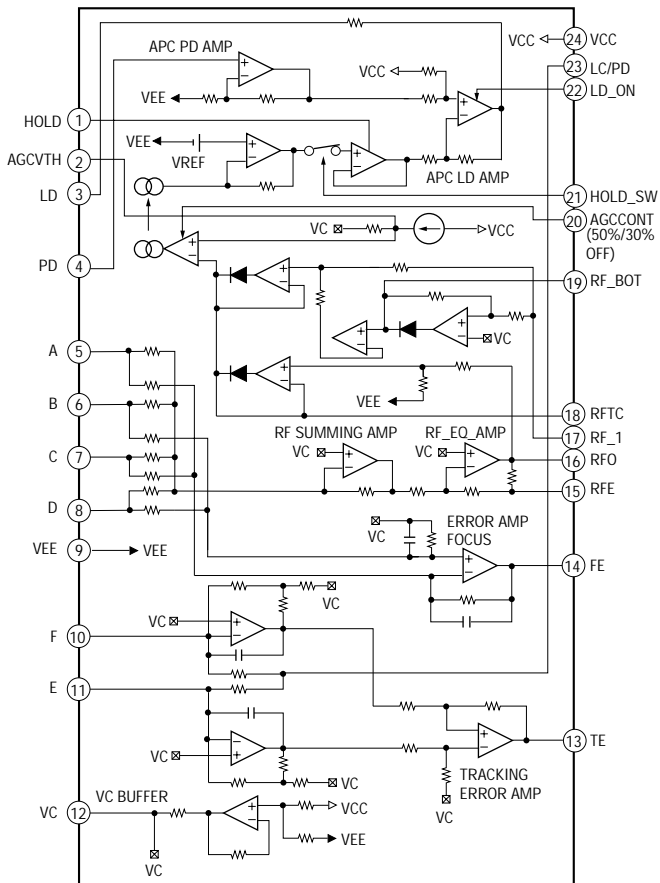

IC302 CXA8055M (MAIN BOARD)

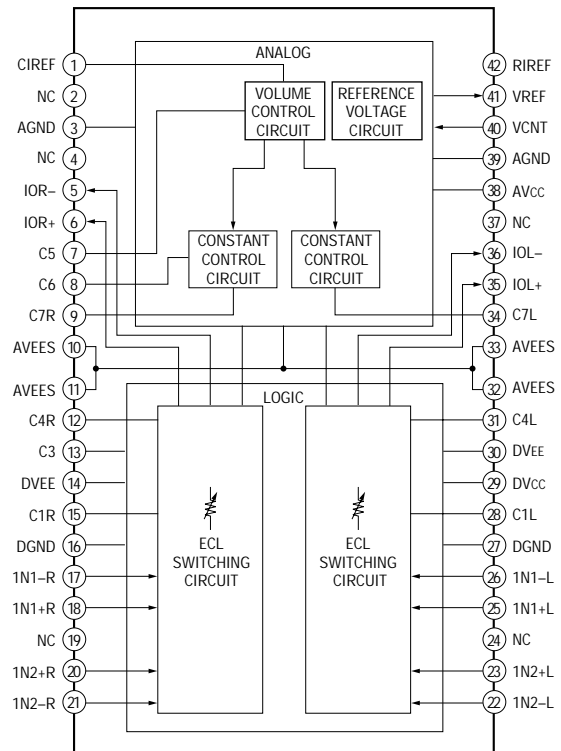

6-15. IC PIN FUNCTION DESCRIPTION

• IC 101 DIGITAL SIGNAL PROCESSOR (CXD2585Q)

Pin No.	Pin Name	I/O	Description
1	DVDD	—	Digital power supply
2	XRST	I	System reset “L” : reset
3	MUTE	I	Muting input “H” : mute
4	DATA	I	Serial data input, supplied from CPU
5	XLAT	I	Latch input, supplied from CPU
6	CLOCK	I	Serial data transfer clock input, supplied from CPU
7	SENS	O	SENS signal output to CPU
8	SCLK	I	SENS serial data read-out clock input
9	ATSK	I	Input pin for anti-shock (Connected to GND)
10	WFCK	O	WFCK output (Not used)
11	XUGF	O	Not used
12	XPCK	O	Not used
13	GFS	O	Not used
14	C2PO	O	Not used
15	SCOR	O	Sub-code sync output
16	CM4	O	4.2336 MHz output (Not used)
17	WDCK	O	Word clock output (f=2fs)
18	DVSS	—	Digital GND
19	COUT	I/O	Numbers of track counted signal input/output (Not used)
20	MIRR	I/O	Mirror signal input/output
21	DFCT	I/O	Defect signal input/output
22	FOK	I/O	Focus OK input/output
23	PWMI	I	Spindle motor external control input (Connected to GND)
24	LOCK	I/O	GFS is sampled by 460 Hz. H when GFS is H (Not used)
25	MDP	O	Output to control spindle motor servo
26	SSTP	I	Input signal to detect disc inner most track
27	FSTO	O	2/3 divider output of pin 71
28	DVDD1	—	Digital power supply
29	SFDR	O	Sled drive output
30	SRDR	O	Sled drive output
31	TFDR	O	Tracking drive output
32	TRDR	O	Tracking drive output
33	FFDR	O	Focus drive output
34	FRDR	O	Focus drive output
35	DVSS1	—	Digital GND
36	TEST	I	TEST pin connected normally to GND
37	TES1	I	TEST pin connected normally to GND
38	VC	I	Center voltage input pin
39	FE	I	Focus error signal input
40	SE	I	Sled error signal input

- Abbreviation
GFS : Guarded Frame Sync

Pin No.	Pin Name	I/O	Description
41	TE	I	Tracking error signal input
42	CE	I	Center servo analog input
43	RFDC	I	RF signal input
44	ADIO	O	Test pin (Not used)
45	AVSS0	—	Analog GND
46	IGEN	I	Stabilized current input for operation amplifiers
47	AVDD0	—	Analog power supply
48	ASYO	O	EFM full swing output
49	ASYI	I	Asymmetry compare voltage input
50	RFAC	I	EFM signal input
51	AVSS1	—	Analog GND
52	CLTV	I	Control voltage input for master VCO1
53	FILO	O	Filter output for master PLL
54	FILI	I	Filter input for master PLL
55	PCO	O	Charge-pump output for master PLL
56	AVDD1	—	Analog power supply
57	BIAS	I	Asymmetry circuit constant current input
58	VCTL	I	VCO2 control voltage input for wide band EFM PLL (Connected to VDD)
59	V16M	I/O	VCO2 oscillator input/output for wide band EFM PLL (Not used)
60	VPCO	O	Charge -pump output for wide band EFM PLL (Not used)
61	DVDD2	—	Digital power supply
62	ASYE	I	Asymmetry circuit ON/OFF input “L” : OFF, “H” : ON (Connected to VDD)
63	MD2	I	Digital-out ON/OFF control input (Connected to VDD)
64	DOUT	O	Digital-out output pin
65	LRCK	O	D/A interface LR clock output (f=F _s)
66	PCMD	O	D/A interface serial data output
67	BCLK	O	D/A interface bit clock output
68	EMPH	O	Playback disc output in emphasis mode (Not used)
69	XTSL	I	X'tal selection input (Connected to ground)
70	DVSS2	—	Digital GND
71	XTAI	I	X'tal oscillator circuit input
72	XTAO	O	X'tal oscillator circuit output (Not used)
73	SOUT	O	Serial data output in servo block (Not used)
74	SOCK	O	Serial data read clock output in servo block (Not used)
75	XOLT	O	Serial data latch output in servo block (Not used)
76	SQSO	O	Sub-Q 80-bit and PCM peak level data output (CD text data output)
77	SQCK	I	Clock input for SQSO read-out
78	SCSY	I	Connected to GND
79	SBSO	O	Sub-P through Sub-W serial output (Not used)
80	EXCK	I	Clock input for SBSO read-out (Connected to GND)

• Abbreviation

EFM : Eight to Fourteen Modulation

PLL : Phase Locked Loop

• IC 801 (SYSTEM CONTROL) CXP82832-009Q

Pin No.	Pin Name	I/O	Description
1	13G	O	Fluorescent display tube grid 13 output
2	14G	O	Fluorescent display tube grid 14 output
3	NC (+5V)	—	Not used. Connected to 5V
4	+5 V (PEO/EC1/1NT0)	—	Not used. Connected to 5V
5	SCOR	I	Signal processing IC data sync input
6	GND (PE2/1NT2)	—	Not used. Connected to GND
7	GND (PE3/1NT3/NM1)	—	Not used. Connected to GND
8	RMIN	I	Remote control input
9	GND (PE5)	—	Not used. Connected to GND
10	X (OPEN)	—	Not used. Open
11	X (OPEN)	—	Not used. Open
12	LDOUT	O	Loading OUT direction output
13	LDIN	O	Loading IN direction output
14	SENS	I	Signal processing IC SENSE input
15	XLT	O	Signal processing IC command latch output
16	D-MUTE	O	Signal processing IC mute output
17	PGML	O	D/F IC command latch output
18	SENSOR IN	I	Stabilizer detect sensor input
19	BUSOUT	O	Control A1 output
20	BUSIN	I	Control A1 input
21	SENSOR SW	I	stabilizer detect sensor switch
22	CLK	O	Signal processing IC command clock output
23	LDIN	O	Laser diode ON/OFF switching output
24	DATA	I	Signal processing IC data input
25	SQCK	O	Signal processing IC SUBQ read clock output
26	SUBQ	I	Signal processing IC SUBQ input
27	+5V	—	Terminal through 5V
28	AVREF	I	AD converter reference voltage input
29	Key 0	I	Key input
30	Key 1	I	Key input
31	Key 2	I	Key input
32	FILTER SW	I	D/F switching rotary switch input
33	ADJ/AFADJ	O	Normal/ADJ/AFADJ mode switching
34	LOADSW	I	Input of IN switch and OUT switch
35	MODEL SEL1	O	MODEL switching terminal (LL: XE520 LH: XB720 HL: XB820 HH: XB920)
36	MODEL SEL2	O	Model selector terminal (LL: XE520 LH: XB720 HL: XB820 HH: XB920)
37	AVSS	I	A/D converter GND input
38	RST	I	Microprocessor reset input
39	EXTAL	—	8 MHz X'tal connection terminal
40	EXTAL	—	8 MHz X'tal connection terminal
41	VSS	—	GND
42	TX	—	Not used. Open
43	TEX	—	Not used. Connected to GND
44	VDD (+5V)	—	5V supply terminal
45	VFDP (-30V)	—	Voltage supply terminal for option pulldown FDP
46	XSEL	—	Not used. Open
47	REINIT	—	Not used. Open
48	REGF	O	RF amplifier, laser power hold output
49	A-MUTE	—	Not used. Open
50	NC	—	Not used. Open

Pin No.	Pin Name	I/O	Description
51	NC	—	Not used. Open
52	NC	—	Not used. Open
53	NC	—	Not used. Open
54	NC	—	Not used. Open
55	NC	—	Not used. Open
56	NC	—	Not used. Open
57	NC	—	Not used. Open
58	NC	—	Not used. Open
59	NC	—	Not used. Open
60	NC	—	Not used. Open
61	NC	—	Not used. Open
62	NC	—	Not used. Open
63	NC	—	Not used. Open
64	NC	—	Not used. Open
65	NC	—	Not used. Open
66	NC	—	Not used. Open
67	S21	O	Fluorescent display tube segment 21 output
68	S20	O	Fluorescent display tube segment 20 output
69	S19	O	Fluorescent display tube segment 19 output
70	S18	O	Fluorescent display tube segment 18 output
71	S17	O	Fluorescent display tube segment 17 output
72	S16	O	Fluorescent display tube segment 16 output
73	S15	O	Fluorescent display tube segment 15 output
74	S14	O	Fluorescent display tube segment 14 output
75	S13	O	Fluorescent display tube segment 13 output
76	S12	O	Fluorescent display tube segment 12 output
77	S11	O	Fluorescent display tube segment 11 output
78	S10	O	Fluorescent display tube segment 10 output
79	S9	O	Fluorescent display tube segment 9 output
80	S8	O	Fluorescent display tube segment 8 output
81	S7	O	Fluorescent display tube segment 7 output
82	S6	O	Fluorescent display tube segment 6 output
83	S5	O	Fluorescent display tube segment 5 output
84	S4	O	Fluorescent display tube segment 4 output
85	S3	O	Fluorescent display tube segment 3 output
86	S2	O	Fluorescent display tube segment 2 output
87	S1	O	Fluorescent display tube segment 1 output
88	1G	O	Fluorescent display tube Grid 1 output
89	VDD (+5V)	—	5 V, VDD
90	2G	O	Fluorescent display tube Grid 2 output
91	3G	O	Fluorescent display tube Grid 3 output
92	4G	O	Fluorescent display tube Grid 4 output
93	5G	O	Fluorescent display tube Grid 5 output
94	6G	O	Fluorescent display tube Grid 6 output
95	7G	O	Fluorescent display tube Grid 7 output
96	8G	O	Fluorescent display tube Grid 8 output
97	9G	O	Fluorescent display tube Grid 9 output
98	10G	O	Fluorescent display tube Grid 10 output
99	11G	O	Fluorescent display tube Grid 11 output
100	12G	O	Fluorescent display tube Grid 12 output

SECTION 7 EXPLODED VIEWS

NOTE:

- -XX, -X mean standardized parts, so they may have some differences from the original one.
- Items marked “*” are not stocked since they are seldom required for routine service. Some delay should be anticipated when ordering these items.
- Abbreviation
 SP :Singapore
 MY :Malaysia

- The mechanical parts with no reference number in the exploded views are not supplied.
- Hardware (# mark) list and accessories and packing materials are given in the last of this parts list.
- Color Indication of Appearance Parts Example:
 KNOB, BALANCE (WHITE) . . . (RED)
 ↑ ↑
 Parts of Color Cabinet's Color

The components identified by mark Δ or dotted line with mark Δ are critical for safety. Replace only with part number specified.

7-1. CASE SECTION

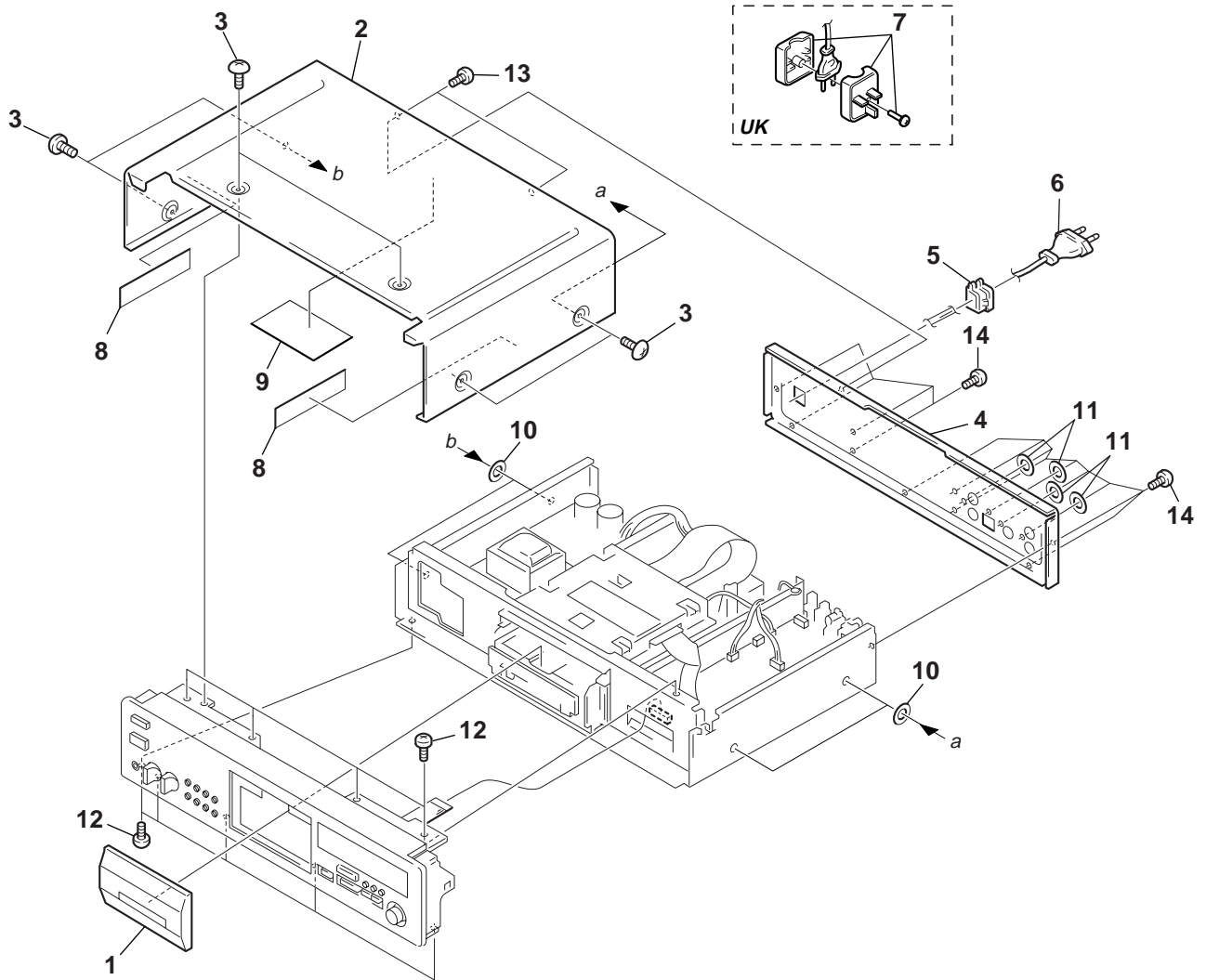

Ref. No.	Part No.	Description	Remarks	Ref. No.	Part No.	Description	Remarks
1	X-4949-884-1	PANEL ASSY, LOADING (BLACK)		8	4-959-077-01	DAMPER	
1	X-4950-218-1	PANEL ASSY, LOADING (SILVER)		9	4-962-329-01	DAMPER	
* 2	4-997-138-01	CASE (4095269) (BLACK)		10	4-949-302-11	WASHER	
* 2	4-997-138-41	CASE (4095269) (SILVER)		11	3-325-697-01	WASHER (XB920/XB920E: UK)	
3	4-210-291-01	SCREW (CASE 3 TP2) (BLACK) (XB920)		11	3-325-697-21	WASHER (XB920E: SP, MY)	
3	4-210-291-11	SCREW (SILVER) (XB920)		12	3-704-515-41	SCREW (BV/RING) (XB920E)	
3	4-999-877-01	SCREW (CASE) (BLACK) (XB920E)		12	3-703-685-21	SCREW (+BV3 × 8) (XB920)	
* 4	4-997-198-01	PANEL, BACK (XB920)		13	3-704-515-21	SCREW (BV/RING) (XB920: BLACK)	
* 4	4-997-198-11	PANEL, BACK (XB920E: UK)		13	3-704-515-31	SCREW (BV/RING) (XB920: SILVER)	
* 4	4-997-198-31	PANEL, BACK (XB920E: SP, MY)		13	3-704-515-41	SCREW (BV/RING) (XB920E)	
5	4-966-267-11	BUSHING (FBS001), CORD		14	3-704-515-21	SCREW (BV/RING) (XB920)	
Δ 6	1-575-651-21	CORD, POWER		14	3-704-515-41	SCREW (BV/RING) (XB920E)	
Δ 7	1-770-019-11	ADAPTOR, CONVERSION PLUG 3P (UK)					

7-2. PANEL SECTION

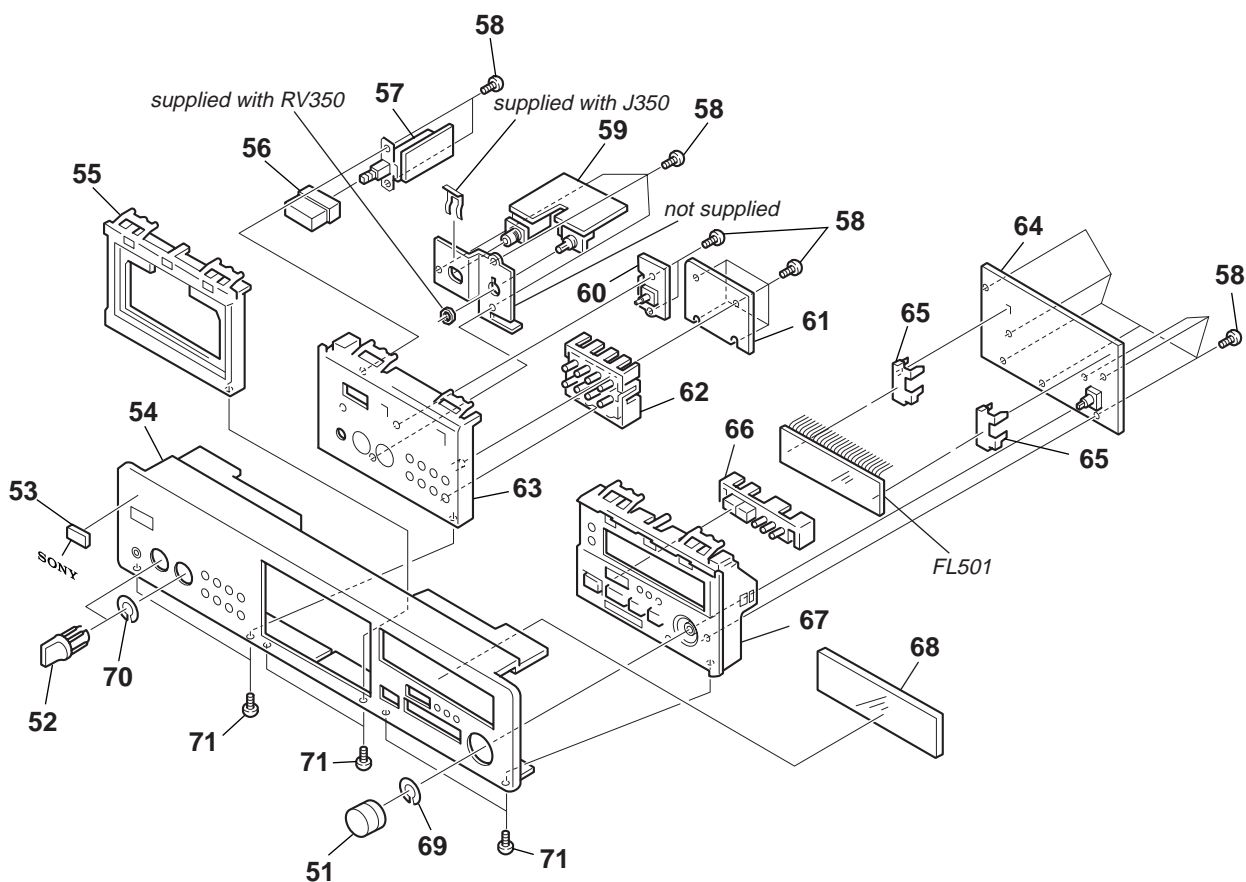

Ref. No.	Part No.	Description	Remarks	Ref. No.	Part No.	Description	Remarks
51	4-996-687-51	KNOB (AMS) (BLACK)		62	4-997-211-01	BUTTON (MODE) (BLACK)	
51	4-996-687-81	KNOB (AMS) (SILVER)		62	4-997-211-21	BUTTON (MODE) (SILVER)	
52	4-950-189-01	KNOB (A) (VOL) (BLACK)		63	4-997-200-01	BASE (L), PANEL (BLACK)	
52	4-950-189-61	KNOB (A) (VOL) (SILVER)		63	4-997-200-21	BASE (L), PANEL (SILVER)	
53	4-942-568-41	EMBLEM (NO.5), SONY		* 64	A-4699-979-A	DISP BOARD, COMPLETE (XB920/XB920E: UK)	
54	4-997-199-01	PANEL, FRONT (BLACK) (XB920)		* 64	A-4724-190-A	DISP BOARD, COMPLETE (XB920E: SP, MY)	
54	4-997-199-11	PANEL, FRONT (BLACK) (XB920E: UK)		* 65	4-997-495-01	GUIDE (FL)	
54	4-997-199-41	PANEL, FRONT (BLACK) (XB920E: SP, MY)		66	4-997-213-01	BUTTON (F.R) (BLACK)	
54	4-997-199-51	PANEL, FRONT (SILVER) (XB920)		66	4-997-213-21	BUTTON (F.R) (SILVER)	
55	4-997-202-01	BASE (M1), PANEL (BLACK)		67	X-4949-458-1	BASE (R) ASSY, PANEL (BLACK)	
55	4-997-202-31	BASE (M1), PANEL (SILVER)		67	X-4950-217-1	BASE (R) ASSY, PANEL (SILVER)	
56	4-998-790-01	KNOB, POWER (BLACK)		68	4-997-210-01	PLATE, INDICATION	
56	4-998-790-21	KNOB, POWER (SILVER)		69	3-354-981-01	SPRING (SUS), RING	
* 57	1-669-370-11	POWER SW BOARD		70	4-948-469-01	SPRING, RING	
58	4-951-620-01	SCREW (2.6 × 8), +BVTP		71	4-967-961-01	SCREW (3 × 8) (XB920E: SP, MY)	
* 59	1-669-372-11	HP BOARD (XB920)		71	4-974-510-01	SCREW (+BV 3 × 8 B) (XB920E: UK)	
* 60	1-670-212-11	ROTARY SW BOARD		71	7-685-646-79	SCREW 3 × 8 TYPE2 N-S (XB920)	
* 61	1-669-371-11	KEY BOARD		FL501	1-517-740-11	INDICATOR TUBE, FLUORESCENT	

7-3. MAIN SECTION

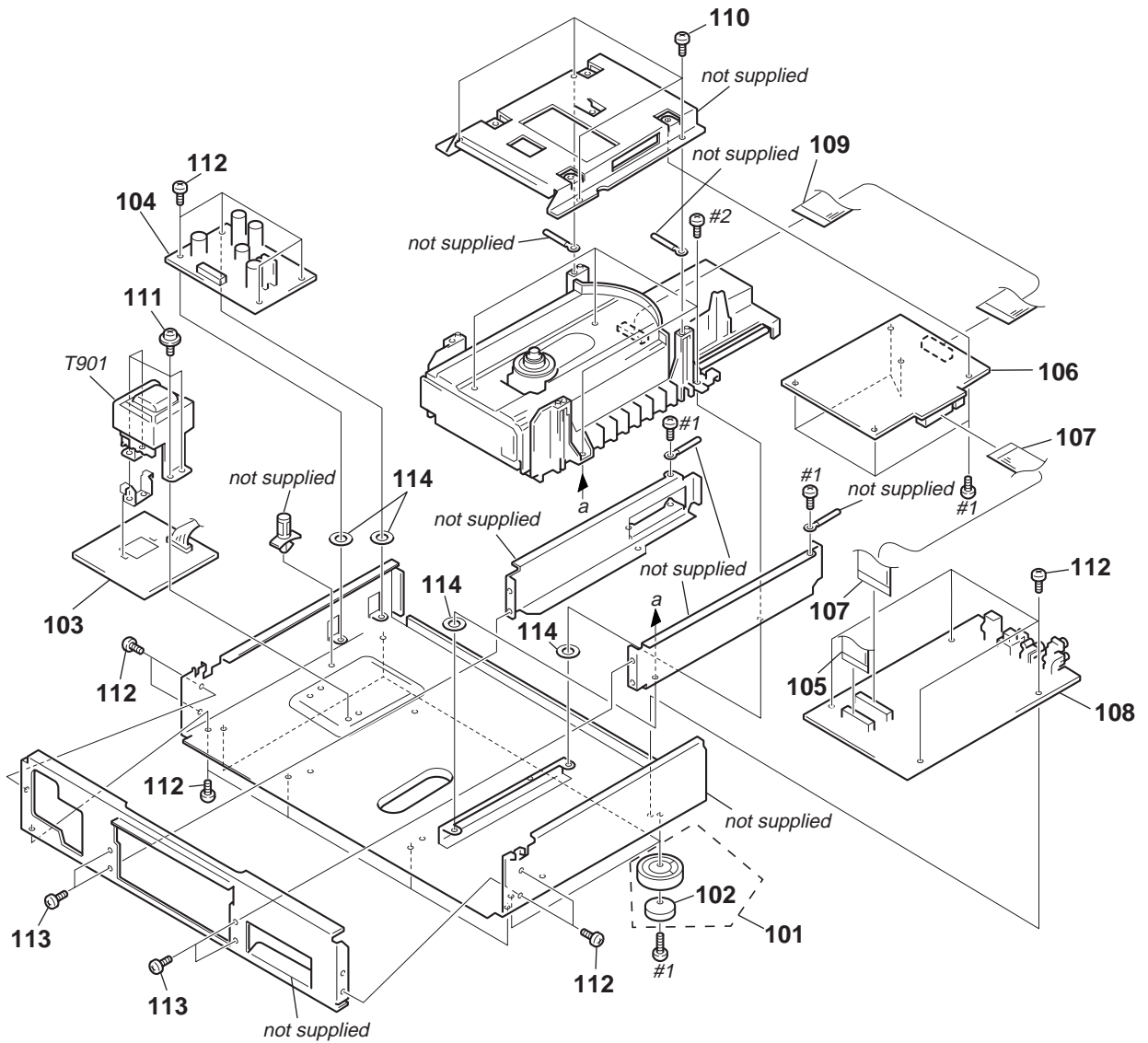

Ref. No.	Part No.	Description	Remarks	Ref. No.	Part No.	Description	Remarks
101	X-4949-523-1	FOOT ASSY (BLACK)		109	1-776-998-11	WIRE (FLAT TYPE) (21 CORE)	
101	X-4950-221-1	FOOT ASSY (SILVER)		110	3-979-112-01	SCREW SW (+) BVTP 3 × 10	
102	4-970-124-01	CUSHION (F50180S)		111	4-886-821-11	SCREW, M3 CASE	
* 103	1-669-373-11	TRANS BOARD		112	4-967-961-01	SCREW (3 × 8) (XB920E: SP, MY)	
* 104	1-669-368-11	POWER BOARD		112	4-974-510-01	SCREW (+BV 3 × 8B) (XB920E: UK)	
* 106	A-4699-989-A	SERVO BOARD, COMPLETE (XB920/XB920E: UK)		112	7-685-646-79	SCREW +BVTP 3 × 8 TYPE N-S (XB920)	
* 106	A-4724-187-A	SERVO BOARD, COMPLETE (XB920E: SP, MY)		113	3-704-515-21	SCREW (BV/RING) (XB920: BLACK)	
107	1-783-598-11	WIRE (FLAT TYPE) (25 CORE)		113	3-704-515-31	SCREW (BV/RING) (XB920: SILVER)	
* 108	A-4699-978-A	MAIN BOARD, COMPLETE (XB920)		113	3-704-515-41	SCREW (BV/RING) (XB920E)	
* 108	A-4724-000-A	MAIN BOARD, COMPLETE (XB920E: UK)		114	4-985-057-01	WASHER	
* 108	A-4724-195-A	MAIN BOARD, COMPLETE (XB920E: SP, MY)		△T901	1-431-902-11	TRANSFORMER, POWER	

The components identified by mark △ or dotted line with mark △ are critical for safety.
Replace only with part number specified.

7-4. CD MECHANISM SECTION (CDM36C-14D)

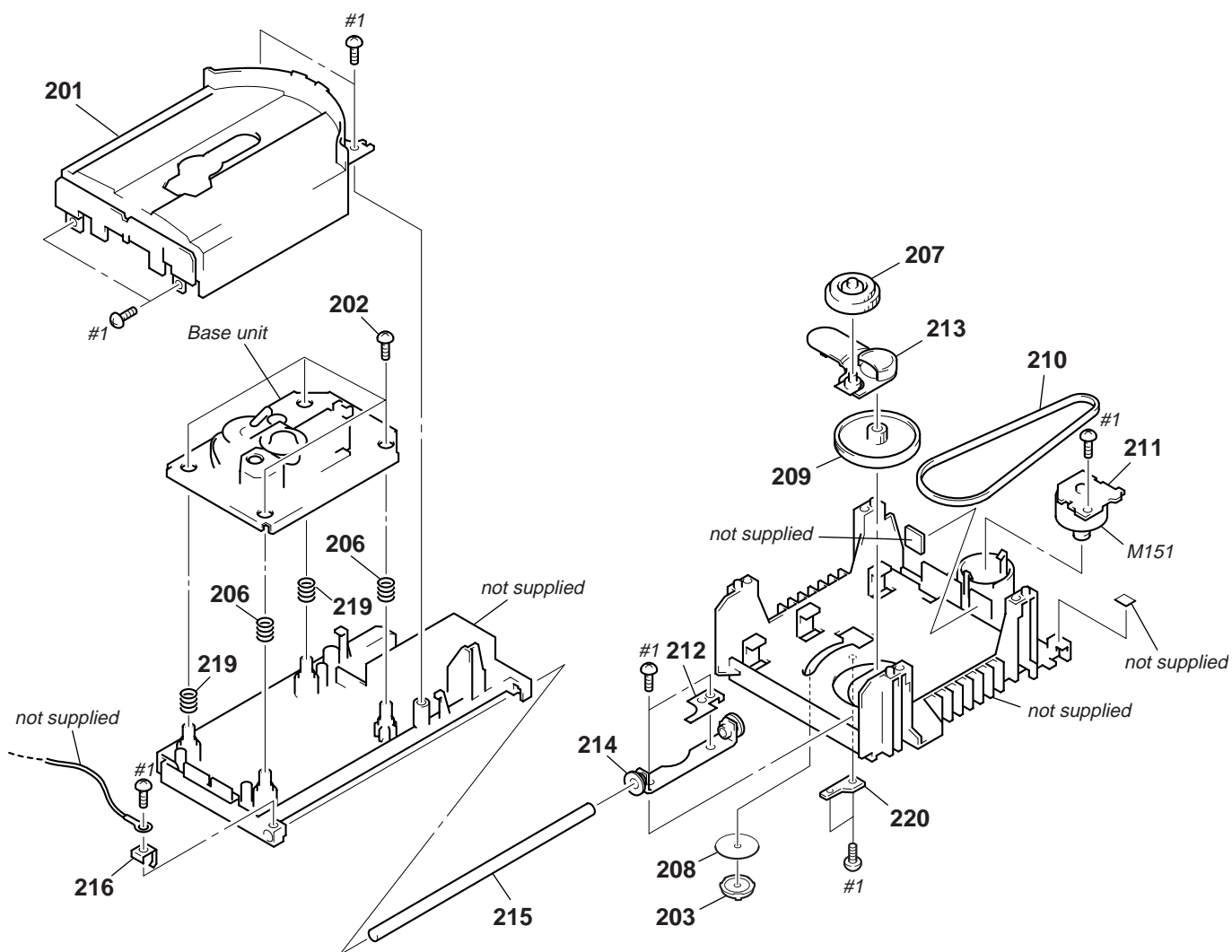

Ref. No.	Part No.	Description	Remarks	Ref. No.	Part No.	Description	Remarks
* 201	4-977-902-01	PANEL (DRAWER)		* 212	4-977-891-01	PLATE, GROUND	
202	4-933-134-01	SCREW (+PTPWH M2.6×6)		213	4-977-898-01	LEVER (SWING)	
203	4-986-919-01	LIMITTER (LEVER)		* 214	4-977-892-01	BEARING	
206	4-989-303-01	SPRING (BU-LF), COMPRESSION		* 215	4-977-888-01	SHAFT	
207	4-977-897-01	GEAR		* 216	4-977-889-01	PLATE (BU), GROUND	
208	4-988-103-01	SLIDER (SWING)		219	4-995-706-01	SPRING, COMPRESSION	
209	4-977-896-01	PULLEY		* 220	1-666-163-11	LD IN SW BOARD	
210	4-968-905-01	BELT (CDM)		M151	A-4660-968-A	MOTOR ASSY (LOADING)	
* 211	1-658-710-11	LOADING BOARD					

7-5. BASE UNIT SECTION (BU-14D)

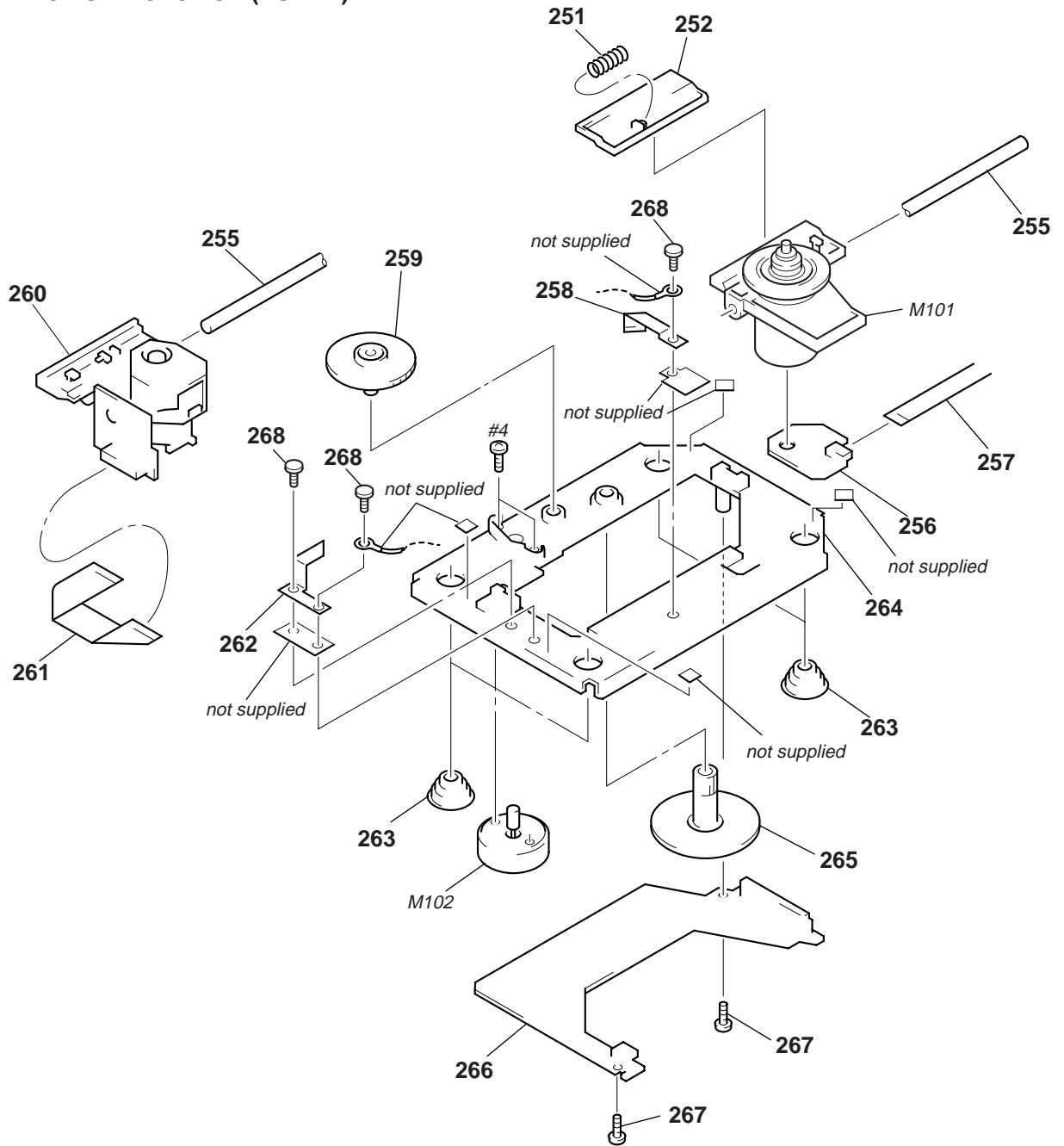

Ref. No.	Part No.	Description	Remarks	Ref. No.	Part No.	Description	Remarks
251	4-977-925-01	SPRING(SLIDE BASE),COMPRESSION		* 262	4-993-919-01	SPRING (A) (OP), LEAF	
252	4-977-926-01	RACK, SLIDE		263	4-917-562-01	INSULATOR	
255	4-977-923-01	SHAFT, SLED		* 264	4-977-918-01	BASE (OUTSERT)	
* 256	1-658-708-11	SPINDLE BOARD		265	4-977-920-01	GEAR (C), FLAT	
257	1-775-990-11	WIRE (FLAT TYPE) (5 CORE)		* 266	1-658-709-11	SLED BOARD	
* 258	4-977-928-01	SPRING (SPINDLE), LEAF		267	4-951-620-01	SCREW (2.6 x 8), +BVTP	
259	4-977-921-01	GEAR (B), FLAT		268	2-279-715-01	RIVET, NYLON	
△ 260	8-848-379-31	OPTICAL PICK-UP BLOCK KSS-213B/K-N		M101	X-4950-461-1	MOTOR ASSY (SPINDLE)	
261	1-775-991-11	WIRE (FLAT TYPE) (16 CORE)		M102	X-4947-303-1	MOTOR ASSY (SLED)	

The components identified by mark △ or dotted line with mark △ are critical for safety. Replace only with part number specified.

SECTION 8 ELECTRICAL PARTS LIST

NOTE:

When indicating parts by reference number, please include the board name.

The components identified by mark Δ or dotted line with mark Δ are critical for safety. Replace only with part number specified.

- Abbreviation
SP :Singapore
MY :Malaysia

- Due to standardization, replacements in the parts list may be different from the parts specified in the diagrams or the components used on the set.
- -XX, -X mean standardized parts, so they may have some difference from the original one.
- Items marked "*" are not stocked since they are seldom required for routine service. Some delay should be anticipated when ordering these items.
- CAPACITORS:
uF: μ F
- RESISTORS
All resistors are in ohms.
METAL: metal-film resistor
METAL OXIDE: Metal Oxide-film resistor
F: nonflammable
- COILS
uH: μ H
- SEMICONDUCTORS
In each case, u: μ , for example:
uA...: μ A... , uPA... , μ PA... ,
uPB... , μ PB... , uPC... , μ PC... ,
uPD... , μ PD...

Ref. No.	Part No.	Description	Remarks		
*	A-4699-979-A	DISP BOARD, COMPLETE *****			
*	4-997-495-01	GUIDE (FL) < CAPACITOR >			
C503	1-164-159-21	CERAMIC	0.1uF		50V
C624	1-164-159-21	CERAMIC	0.1uF		50V
C804	1-164-159-21	CERAMIC	0.1uF		50V
C806	1-164-159-21	CERAMIC	0.1uF		50V
C807	1-124-584-00	ELECT	100uF	20%	10V
C810	1-126-868-11	ELECT	47uF	20%	50V
C813	1-124-584-00	ELECT	100uF	20%	10V
		< CONNECTOR >			
CN501	1-568-838-11	SOCKET, CONNECTOR 21P < DIODE >			
D621	8-719-815-85	DIODE 1S1585			
D958	8-719-110-03	DIODE RD7.5ESB2 < FILTER >			
FL501	1-517-740-11	INDICATOR TUBE, FLUORESCENT < IC >			
IC801	8-752-888-75	IC CXP82832-009Q			
IC802	8-749-014-66	IC NJL56H400A (REMOTE SENSOR) < FILTER >			
LPF904	1-424-122-11	FILTER, NOISE			
LPF905	1-424-122-11	FILTER, NOISE < TRANSISTOR >			
Q621	8-729-119-78	TRANSISTOR 2SC403SP-51			
Q801	8-729-029-66	TRANSISTOR DTC114ESA			
Q802	8-729-029-66	TRANSISTOR DTC114ESA < RESISTOR >			
R535	1-249-429-11	CARBON	10K	5%	1/4W
R536	1-249-427-11	CARBON	6.8K	5%	1/4W F
R539	1-249-429-11	CARBON	10K	5%	1/4W
R541	1-247-807-31	CARBON	100	5%	1/4W
R542	1-247-807-31	CARBON	100	5%	1/4W
R624	1-249-393-11	CARBON	10	5%	1/4W F
R625	1-249-429-11	CARBON	10K	5%	1/4W
R626	1-249-425-11	CARBON	4.7K	5%	1/4W F
R811	1-249-427-11	CARBON	6.8K	5%	1/4W F
R812	1-249-415-11	CARBON	680	5%	1/4W F

Ref. No.	Part No.	Description	Remarks			
R813	1-249-417-11	CARBON	1K	5%	1/4W	F
R814	1-249-419-11	CARBON	1.5K	5%	1/4W	F
R815	1-249-421-11	CARBON	2.2K	5%	1/4W	F
R816	1-247-843-11	CARBON	3.3K	5%	1/4W	
R821	1-249-427-11	CARBON	6.8K	5%	1/4W	F
R822	1-249-415-11	CARBON	680	5%	1/4W	F
R823	1-249-417-11	CARBON	1K	5%	1/4W	F
R824	1-249-419-11	CARBON	1.5K	5%	1/4W	F
R825	1-249-421-11	CARBON	2.2K	5%	1/4W	F
R826	1-247-843-11	CARBON	3.3K	5%	1/4W	
R830	1-249-427-11	CARBON	6.8K	5%	1/4W	F
R831	1-249-441-11	CARBON	100K	5%	1/4W	
R832	1-249-441-11	CARBON	100K	5%	1/4W	
R834	1-249-417-11	CARBON	1K	5%	1/4W	F
R837	1-249-429-11	CARBON	10K	5%	1/4W	
R838	1-249-429-11	CARBON	10K	5%	1/4W	
R851	1-249-427-11	CARBON	6.8K	5%	1/4W	F
R953	1-249-437-11	CARBON	47K	5%	1/4W	
Δ R961	1-212-869-00	FUSIBLE	33	5%	1/4W	F
Δ R962	1-212-869-00	FUSIBLE	33	5%	1/4W	F
		< SWITCH >				
S511	1-554-303-21	SWITCH, TACTILE (REW)				
S512	1-554-303-21	SWITCH, TACTILE (FF)				
S513	1-554-303-21	SWITCH, TACTILE (EDIT/TIME FADE)				
S514	1-554-303-21	SWITCH, TACTILE (CHECK)				
S515	1-554-303-21	SWITCH, TACTILE (CLEAR)				
S521	1-554-303-21	SWITCH, TACTILE (EJECT)				
S522	1-554-303-21	SWITCH, TACTILE (PLAY)				
S523	1-554-303-21	SWITCH, TACTILE (PAUSE)				
S524	1-554-303-21	SWITCH, TACTILE (STOP)				
S531	1-475-543-11	ENCODER, ROTARY (AMS)				
		< VIBRATOR >				
X501	1-579-125-11	VIBRATOR, CERAMIC 8MHz *****				
*	1-669-372-11	HP BOARD (XB920) *****				
*	4-962-201-01	PLATE (HP), GROUND < CAPACITOR >				
C350	1-162-294-31	CERAMIC	0.001uF	10%	50V	
C351	1-162-294-31	CERAMIC	0.001uF	10%	50V	
C352	1-164-159-21	CERAMIC	0.1uF		50V	
		< JACK >				
J350	1-750-162-61	JACK (LARGE TYPE) (PHONES)				

HP

KEY

LD IN SW

LOADING

MAIN

Ref. No.	Part No.	Description	Remarks
		< COIL >	
L350	1-410-507-11	INDUCTOR 6.8uH	
L351	1-410-507-11	INDUCTOR 6.8uH	
L352	1-424-122-11	FILTER, NOISE	
		< VARIABLE RESISTOR >	
RV350	1-223-926-11	RES, VAR, CARBON 1K/1K (PHONE LEVEL)	

*	1-669-371-11	KEY BOARD	

		< RESISTOR >	
R602	1-249-415-11	CARBON 680 5% 1/4W F	
R603	1-249-417-11	CARBON 1K 5% 1/4W F	
R604	1-249-419-11	CARBON 1.5K 5% 1/4W F	
R605	1-249-421-11	CARBON 2.2K 5% 1/4W F	
R606	1-247-843-11	CARBON 3.3K 5% 1/4W	
R607	1-249-427-11	CARBON 6.8K 5% 1/4W F	
R608	1-249-431-11	CARBON 15K 5% 1/4W	
		< SWITCH >	
S601	1-554-303-21	SWITCH, TACTILE (LANGUAGE)	
S602	1-554-303-21	SWITCH, TACTILE (MUSIC SCAN)	
S603	1-554-303-21	SWITCH, TACTILE (AUTO SPACE)	
S604	1-554-303-21	SWITCH, TACTILE (REPEAT)	
S605	1-554-303-21	SWITCH, TACTILE (FADER)	
S606	1-554-303-21	SWITCH, TACTILE (TIME/TEXT)	
S607	1-554-303-21	SWITCH, TACTILE (PEAK SEARCH)	
S608	1-554-303-21	SWITCH, TACTILE (PLAY MODE)	

*	1-666-163-11	LD IN SW BOARD	

		< SWITCH >	
S152	1-762-424-11	SWITCH, MICRO (LOADING)	

*	1-658-710-11	LOADING BOARD	

		< MOTOR >	
M101		MOTOR ASSY (LOADING)	

*	A-4724-000-A	MAIN BOARD, COMPLETE (XB920E:UK)	

*	A-4724-195-A	MAIN BOARD, COMPLETE (XB920E:SP, MY)	

*	A-4699-978-A	MAIN BOARD, COMPLETE (XB920)	

		< CAPACITOR >	
C259	1-161-494-00	CERAMIC 0.022uF 25V	
C260	1-162-215-31	CERAMIC 47PF 5% 50V	
C271	1-124-673-11	ELECT 100uF 20% 10V	
C272	1-161-494-00	CERAMIC 0.022uF 25V	
C273	1-161-494-00	CERAMIC 0.022uF 25V	

Ref. No.	Part No.	Description	Remarks
C274	1-161-494-00	CERAMIC 0.022uF 25V	
C280	1-102-110-00	CERAMIC 220PF 10% 50V	
C281	1-164-159-21	CERAMIC 0.1uF 50V	
C316	1-119-779-11	ELECT 220uF 20% 10V	
C341	1-125-937-21	ELECT 2200uF 0 10V	
C342	1-136-850-11	FILM 0.1uF 5% 63V	
C343	1-126-049-11	ELECT 22uF 20% 50V	
C344	1-136-177-00	FILM 1uF 5% 50V	
C345	1-128-197-11	ELECT 10uF 20% 50V	
C346	1-126-916-11	ELECT 1000uF 20% 6.3V	
C353	1-102-114-00	CERAMIC 470PF 10% 50V	
C355	1-102-106-00	CERAMIC 100PF 10% 50V	
C356	1-101-005-00	CERAMIC 22000PF 50V	
C357	1-162-208-31	CERAMIC 24PF 5% 50V	
C358	1-102-945-00	CERAMIC 8.0PF +-0.5PF 50V	
C359	1-102-945-00	CERAMIC 8.0PF +-0.5PF 50V	
C360	1-162-208-31	CERAMIC 24PF 5% 50V	
C361	1-119-779-11	ELECT 220uF 20% 10V	
C362	1-136-177-00	FILM 1uF 5% 50V	
C363	1-125-890-21	ELECT 1000uF 20% 6.3V	
C365	1-162-208-31	CERAMIC 24PF 5% 50V	
C366	1-136-177-00	FILM 1uF 5% 50V	
C367	1-136-177-00	FILM 1uF 5% 50V	
C381	1-136-177-00	FILM 1uF 5% 50V	
C382	1-136-177-00	FILM 1uF 5% 50V	
C384	1-136-177-00	FILM 1uF 5% 50V	
C386	1-136-177-00	FILM 1uF 5% 50V	
C387	1-119-779-11	ELECT 220uF 20% 10V	
C389	1-136-177-00	FILM 1uF 5% 50V	
C390	1-136-165-00	FILM 0.1uF 5% 50V	
C391	1-136-177-00	FILM 1uF 5% 50V	
C392	1-119-779-11	ELECT 220uF 20% 10V	
C393	1-136-177-00	FILM 1uF 5% 50V	
C404	1-136-177-00	FILM 1uF 5% 50V	
C405	1-119-779-11	ELECT 220uF 20% 10V	
C406	1-136-177-00	FILM 1uF 5% 50V	
C407	1-119-779-11	ELECT 220uF 20% 10V	
C409	1-136-593-11	FILM 0.0033uF 5% 100V	
C410	1-102-959-00	CERAMIC 22PF 5% 50V	
C411	1-102-959-00	CERAMIC 22PF 5% 50V	
C412	1-136-252-00	FILM 0.0015uF 5% 100V	
C413	1-136-813-11	FILM 680PF 5% 100V	
C414	1-136-580-11	FILM 0.47uF 10% 200V	
C415	1-125-781-21	ELECT 220uF 20% 35V	
C419	1-101-005-00	CERAMIC 22000PF 50V	
C420	1-130-955-00	FILM 0.01uF 5% 100V	
C421	1-130-955-00	FILM 0.01uF 5% 100V	
C423	1-128-197-11	ELECT 10uF 20% 50V	
C424	1-136-850-11	FILM 0.1uF 5% 63V	
C425	1-136-177-00	FILM 1uF 5% 50V	
C426	1-136-850-11	FILM 0.1uF 5% 63V	
C427	1-136-802-11	FILM 0.015uF 5% 100V	
C428	1-128-197-11	ELECT 10uF 20% 63V	
C429	1-128-200-11	ELECT 47uF 20% 63V	
C430	1-136-177-00	FILM 1uF 5% 50V	
C431	1-136-230-00	FILM 0.0022uF 5% 100V	
C432	1-136-230-00	FILM 0.0022uF 5% 100V	
C433	1-102-947-00	CERAMIC 10PF 5% 50V	
C434	1-162-190-31	CERAMIC 1.8PF 20% 50V	
C435	1-136-177-00	FILM 1uF 5% 50V	

MAIN

Ref. No.	Part No.	Description	Remarks	Ref. No.	Part No.	Description	Remarks
C436	1-136-177-00	FILM	1uF 5% 50V	* CN304	1-568-841-11	SOCKET, CONNECTOR 25P	
C437	1-136-177-00	FILM	1uF 5% 50V	CN305	1-568-838-11	SOCKET, CONNECTOR 21P	
C440	1-136-165-00	FILM	0.1uF 5% 50V	CN351	1-506-468-11	PIN, CONNECTOR 3P (XB920)	
			(XB920)			< DIODE >	
C504	1-136-177-00	FILM	1uF 5% 50V	D261	8-719-815-85	DIODE 1S1585	
C505	1-119-779-11	ELECT	220uF 20% 10V	D262	8-719-815-85	DIODE 1S1585	
C506	1-136-177-00	FILM	1uF 5% 50V	D263	8-719-815-85	DIODE 1S1585	
C507	1-119-779-11	ELECT	220uF 20% 10V	D264	8-719-815-85	DIODE 1S1585	
C508	1-119-837-11	ELECT	100uF 20% 63V	D301	8-719-210-21	DIODE 11EQS04	
C509	1-136-593-11	FILM	0.0033uF 5% 100V	D302	8-719-210-21	DIODE 11EQS04	
C510	1-102-959-00	CERAMIC	22PF 5% 50V	D303	8-719-210-21	DIODE 11EQS04	
C511	1-102-959-00	CERAMIC	22PF 5% 50V	D305	8-719-210-21	DIODE 11EQS04	
C512	1-136-252-00	FILM	0.0015uF 5% 100V	D306	8-719-200-82	DIODE 11ES2	
C513	1-136-813-11	FILM	680PF 5% 100V	D307	8-719-200-82	DIODE 11ES2	
C514	1-136-580-11	FILM	0.47uF 10% 200V	D308	8-719-200-82	DIODE 11ES2	
C515	1-125-781-21	ELECT	220uF 20% 35V	D310	8-719-815-85	DIODE 1S1585	
C519	1-101-005-00	CERAMIC	22000PF 50V	D311	8-719-210-21	DIODE 11EQS04	
C520	1-130-955-00	FILM	0.01uF 5% 100V	D312	8-719-210-21	DIODE 11EQS04	
C521	1-130-955-00	FILM	0.01uF 5% 100V	D351	8-719-815-85	DIODE 1S1585	
C523	1-128-197-11	ELECT	10uF 20% 50V	D352	8-719-815-85	DIODE 1S1585	
C524	1-136-850-11	FILM	0.1uF 5% 63V	D353	8-719-815-85	DIODE 1S1585	
C525	1-136-177-00	FILM	1uF 5% 50V	D354	8-719-815-85	DIODE 1S1585	
C527	1-136-802-11	FILM	0.015uF 5% 100V	D355	8-719-815-85	DIODE 1S1585	
C529	1-128-200-11	ELECT	47uF 20% 63V	D356	8-719-815-85	DIODE 1S1585	
C530	1-136-177-00	FILM	1uF 5% 50V	D957	8-719-117-20	DIODE RD36JS-T1AB2	
C531	1-136-230-00	FILM	0.0022uF 5% 100V			< IC >	
C532	1-136-230-00	FILM	0.0022uF 5% 100V	IC203	8-759-242-70	IC TC7WU04F	
C533	1-102-947-00	CERAMIC	10PF 5% 50V	IC208	8-749-921-12	IC GP1F32T (OPTICAL)	
C534	1-162-190-31	CERAMIC	1.8PF 20% 50V	IC251	8-759-242-70	IC TC7WU04F	
C535	1-136-177-00	FILM	1uF 5% 50V	IC301	8-759-527-07	IC CXD8735N	
C536	1-136-177-00	FILM	1uF 5% 50V	IC302	8-759-361-58	IC CXA8055M	
C537	1-136-177-00	FILM	1uF 5% 50V	IC304	8-759-710-59	IC NJM4580D-D (XB920)	
C540	1-136-165-00	FILM	0.1uF 5% 50V	IC401	8-759-712-02	IC NJM2114D	
			(XB920)	IC402	8-759-602-83	IC M5238P	
C609	1-126-868-11	ELECT	47uF 20% 50V	IC501	8-759-712-02	IC NJM2114D	
C811	1-126-013-11	ELECT	1000uF 20% 16V	IC502	8-759-602-83	IC M5238P	
C812	1-126-335-11	ELECT	220uF 20% 10V	IC902	8-759-231-53	IC TA7805S	
C814	1-136-177-00	FILM	1uF 5% 50V	IC903	8-759-231-58	IC TA7812S	
C815	1-136-177-00	FILM	1uF 5% 50V	IC904	8-759-245-86	IC TA7912S	
C820	1-162-294-31	CERAMIC	0.001uF 10% 50V	IC905	8-759-231-53	IC TA7805S	
C821	1-126-046-11	ELECT	3.3uF 20% 50V	IC906	8-759-604-90	IC M5F7907L	
C822	1-161-494-00	CERAMIC	0.022uF 25V	IC920	8-759-636-16	IC M51957AL	
C823	1-161-494-00	CERAMIC	0.022uF 25V			< JACK >	
C903	1-136-177-00	FILM	1uF 5% 50V	J301	1-774-727-11	JACK, PIN 2P (LINE OUT)	
C904	1-136-177-00	FILM	1uF 5% 50V	J351	1-770-905-21	JACK, PIN 1P (COAXIAL)	
C905	1-126-234-11	ELECT	2200uF 20% 16V	J352	1-774-726-11	JACK (S-LINK CONTROL A1)	
C906	1-126-234-11	ELECT	2200uF 20% 16V			< COIL >	
C953	1-128-197-11	ELECT	10uF 20% 63V	L251	1-410-322-11	INDUCTOR 3.3uH	
C961	1-126-023-11	ELECT	100uF 20% 25V	L252	1-410-322-11	INDUCTOR 3.3uH	
			(XB920)	L302	1-410-322-11	INDUCTOR 3.3uH	
C962	1-126-023-11	ELECT	100uF 20% 25V	L303	1-410-322-11	INDUCTOR 3.3uH	
			(XB920)	L304	1-410-322-11	INDUCTOR 3.3uH	
		< CONNECTOR >					
CN201	1-691-765-21	PLUG (MICRO CONNECTOR) 3P					
CN202	1-691-765-11	PLUG (MICRO CONNECTOR) 3P					
CN301	1-691-767-11	PLUG (MICRO CONNECTOR) 5P					
CN302	1-691-768-11	PLUG (MICRO CONNECTOR) 6P					
* CN303	1-568-954-11	PIN, CONNECTOR 5P					

Ref. No.	Part No.	Description	Remarks	Ref. No.	Part No.	Description	Remarks
L305	1-410-322-11	INDUCTOR 3.3uH		R382	1-259-418-81	CARBON 390 5%	1/6W
L306	1-410-521-11	INDUCTOR 100uH		R405	1-249-462-11	CARBON 22K 5%	1/4W
L312	1-410-781-11	INDUCTOR 33mH		R406	1-249-462-11	CARBON 22K 5%	1/4W
L313	1-410-781-11	INDUCTOR 33mH		R407	1-249-586-81	CARBON 27K 5%	1/4W
L315	1-410-767-11	INDUCTOR 2.2mH		R408	1-249-586-81	CARBON 27K 5%	1/4W
L353	1-410-397-21	FERRITE BEAD INDUCTOR (XB920)		R409	1-249-556-11	CARBON 1.5K 5%	1/4W
L401	1-410-781-11	INDUCTOR 33mH		R411	1-247-891-00	CARBON 330K 5%	1/4W
L402	1-424-122-11	FILTER, NOISE		R413	1-247-714-11	CARBON 1.2K 5%	1/4W
L501	1-410-781-11	INDUCTOR 33mH		R414	1-259-420-11	CARBON 470 5%	1/6W
L502	1-424-122-11	FILTER, NOISE		R416	1-249-923-11	CARBON 1K 5%	1/4W
L951	1-412-473-21	INDUCTOR 0uH (XB920)		R417	1-410-322-11	INDUCTOR 3.3UH	
		< FILTER >		R418	1-259-476-11	CARBON 100K 5%	1/6W
				R419	1-259-420-11	CARBON 470 5%	1/6W (XB920)
LPF901	1-424-153-11	FILTER, NOISE		R420	1-249-524-11	CARBON 68 5%	1/4W
LPF902	1-424-153-11	FILTER, NOISE		R421	1-249-524-11	CARBON 68 5%	1/4W
LPF903	1-424-153-11	FILTER, NOISE					
		< TRANSISTOR >		R422	1-249-524-11	CARBON 68 5%	1/4W
Q302	8-729-029-56	TRANSISTOR DTA144ESA		R423	1-249-524-11	CARBON 68 5%	1/4W
Q303	8-729-029-56	TRANSISTOR DTA144ESA		R424	1-247-690-11	CARBON 15 5%	1/4W F
Q402	8-729-231-55	TRANSISTOR 2SC2878-AB		R425	1-247-690-11	CARBON 15 5%	1/4W F
Q403	8-729-231-55	TRANSISTOR 2SC2878-AB (XB920)		R430	1-247-690-11	CARBON 15 5%	1/4W F
Q502	8-729-231-55	TRANSISTOR 2SC2878-AB					
Q503	8-729-231-55	TRANSISTOR 2SC2878-AB (XB920)		R431	1-247-690-11	CARBON 15 5%	1/4W F
Q951	8-729-019-65	TRANSISTOR 2SB1041T103		R432	1-247-714-11	CARBON 1.2K 5%	1/4W F (XB920/XB920E:UK)
		< RESISTOR >					
R254	1-259-380-11	CARBON 10 5%	1/6W	R432	1-247-708-11	CARBON 470 5%	1/4W F (XB920E:SP, MY)
R255	1-259-428-11	CARBON 1K 5%	1/6W	R433	1-247-714-11	CARBON 1.2K 5%	1/4W F (XB920/XB920E:UK)
R256	1-259-396-11	CARBON 47 5%	1/6W				
R257	1-259-380-11	CARBON 10 5%	1/6W	R433	1-247-708-11	CARBON 470 5%	1/4W F (XB920E:SP, MY)
R258	1-259-428-11	CARBON 1K 5%	1/6W				
R259	1-259-428-11	CARBON 1K 5%	1/6W	R444	1-249-405-11	CARBON 100 5%	1/4W F
R260	1-259-428-11	CARBON 1K 5%	1/6W	R445	1-249-405-11	CARBON 100 5%	1/4W F
R262	1-259-396-11	CARBON 47 5%	1/6W	R451	1-259-472-11	CARBON 68K 5%	1/6W (XB920)
R263	1-259-380-11	CARBON 10 5%	1/6W				
R281	1-259-404-11	CARBON 100 5%	1/6W	R452	1-259-480-11	CARBON 150K 5%	1/6W (XB920)
R303	1-259-428-11	CARBON 1K 5%	1/6W	R453	1-259-484-11	CARBON 220K 5%	1/6W (XB920)
R306	1-259-492-11	CARBON 470K 5%	1/6W				
R312	1-259-428-11	CARBON 1K 5%	1/6W	R454	1-259-492-11	CARBON 470K 5%	1/6W (XB920)
R313	1-259-416-11	CARBON 330 5%	1/6W				
R314	1-259-440-11	CARBON 3.3K 5%	1/6W (XB920/XB920E:SP, MY)	R455	1-259-396-11	CARBON 47 5%	1/6W (XB920)
R314	1-259-466-11	CARBON 39K 5%	1/6W (XB920E:UK)	R505	1-249-462-11	CARBON 22K 5%	1/4W
R318	1-259-476-11	CARBON 100K 5%	1/6W	R506	1-249-462-11	CARBON 22K 5%	1/4W
R319	1-259-476-11	CARBON 100K 5%	1/6W	R507	1-249-586-81	CARBON 27K 5%	1/4W
R331	1-259-428-11	CARBON 1K 5%	1/6W				
R332	1-259-428-11	CARBON 1K 5%	1/6W	R508	1-249-586-81	CARBON 27K 5%	1/4W
R341	1-259-452-11	CARBON 10K 5%	1/6W	R509	1-249-556-11	CARBON 1.5K 5%	1/4W
R342	1-259-452-11	CARBON 10K 5%	1/6W	R511	1-247-891-00	CARBON 330K 5%	1/4W
R350	1-259-452-11	CARBON 10K 5%	1/6W	R513	1-247-714-11	CARBON 1.2K 5%	1/4W
R351	1-259-428-11	CARBON 1K 5%	1/6W	R514	1-259-420-11	CARBON 470 5%	1/6W
R352	1-259-428-11	CARBON 1K 5%	1/6W				
R353	1-259-428-11	CARBON 1K 5%	1/6W	R516	1-249-923-11	CARBON 1K 5%	1/4W
R360	1-259-436-11	CARBON 2.2K 5%	1/6W	R517	1-410-322-11	INDUCTOR 3.3UH	
R361	1-259-436-11	CARBON 2.2K 5%	1/6W	R518	1-259-476-11	CARBON 100K 5%	1/6W
R362	1-259-436-11	CARBON 2.2K 5%	1/6W	R519	1-259-420-11	CARBON 470 5%	1/6W (XB920)
R381	1-259-432-11	CARBON 1.5K 5%	1/6W				
				R520	1-249-524-11	CARBON 68 5%	1/4W
				R521	1-249-524-11	CARBON 68 5%	1/4W
				R522	1-249-524-11	CARBON 68 5%	1/4W
				R523	1-249-524-11	CARBON 68 5%	1/4W
				R524	1-247-690-11	CARBON 15 5%	1/4W F
				R525	1-247-690-11	CARBON 15 5%	1/4W F

MAIN	POWER	POWER SW	ROTARY SW
-------------	--------------	-----------------	------------------

Ref. No.	Part No.	Description	Remarks
R530	1-247-690-11	CARBON	15 5% 1/4W F
R531	1-247-690-11	CARBON	15 5% 1/4W F
R532	1-247-714-11	CARBON	1.2K 5% 1/4W F (XB920/XB920E:UK)
R532	1-247-708-11	CARBON	470 5% 1/4W F (XB920E:SP, MY)
R533	1-247-714-11	CARBON	1.2K 5% 1/4W F (XB920/XB920E:UK)
R533	1-247-708-11	CARBON	470 5% 1/4W F (XB920E:SP, MY)
R534	1-259-476-11	CARBON	100K 5% 1/6W
R544	1-249-405-11	CARBON	100 5% 1/4W F
R545	1-249-405-11	CARBON	100 5% 1/4W F
R551	1-259-472-11	CARBON	68K 5% 16W (XB920)
R552	1-259-480-11	CARBON	150K 5% 16W (XB920)
R553	1-259-484-11	CARBON	220K 5% 1/6W (XB920)
R554	1-259-492-11	CARBON	470K 5% 1/6W (XB920)
R555	1-259-396-11	CARBON	47 5% 1/6W (XB920)
R820	1-259-456-11	CARBON	15K 5% 1/6W
R931	1-259-466-11	CARBON	39K 5% 1/6W
R932	1-259-440-11	CARBON	3.3K 5% 1/6W
R951	1-212-869-00	FUSIBLE	33 5% 1/4W F
R952	1-259-452-11	CARBON	10K 5% 1/6W
R971	1-259-420-11	CARBON	470 5% 1/6W (XB920)
R972	1-259-420-11	CARBON	470 5% 1/6W (XB920)
< TRANSFORMER >			
T201	1-409-594-11	COIL (WITH CORE)	
< VIBRATOR >			
X301	1-767-926-11	VIBRATOR, CRYSTAL 45MHz	

*	1-669-368-11	POWER BOARD	*****
	7-685-871-01	SCREW +BVTT 3 × 6 (S)	
< CAPACITOR >			
C901	1-117-912-11	ELECT	3900uF 20% 25V
C902	1-117-912-11	ELECT	3900uF 20% 25V
C910	1-136-177-00	FILM	1uF 5% 50V
C911	1-117-810-11	ELECT	6800uF 20% 25V
C915	1-126-012-11	ELECT	470uF 20% 16V
C916	1-136-177-00	FILM	1uF 5% 50V
C921	1-126-943-11	ELECT	2200uF 20% 25V
C922	1-126-013-11	ELECT	1000uF 20% 16V
C924	1-136-850-11	FILM	0.1uF 5% 63V
C931	1-136-177-00	FILM	1uF 5% 50V
C932	1-136-177-00	FILM	1uF 5% 50V
C951	1-128-089-11	ELECT	330uF 20% 63V
C952	1-124-911-11	ELECT	220uF 20% 50V
C954	1-136-850-11	FILM	0.1uF 5% 63V
C955	1-136-177-00	FILM	1uF 5% 50V

Ref. No.	Part No.	Description	Remarks
< CONNECTOR >			
CN901	1-691-771-11	PLUG (MICRO CONNECTOR) 9P	
CN902	1-691-767-11	PLUG (MICRO CONNECTOR) 5P	
CN903	1-691-768-11	PLUG (MICRO CONNECTOR) 6P	
CN904	1-691-765-11	PLUG (MICRO CONNECTOR) 3P	
< DIODE >			
D901	8-719-210-21	DIODE 11EQS04	
D902	8-719-210-21	DIODE 11EQS04	
D903	8-719-210-21	DIODE 11EQS04	
D904	8-719-210-21	DIODE 11EQS04	
D911	8-719-210-21	DIODE 11EQS04	
D912	8-719-210-21	DIODE 11EQS04	
D913	8-719-210-21	DIODE 11EQS04	
D914	8-719-210-21	DIODE 11EQS04	
D921	8-719-815-85	DIODE 1S1585	
D922	8-719-115-38	DIODE RD5.1JS-T1B2	
D923	8-719-815-85	DIODE 1S1585	
D924	8-719-815-85	DIODE 1S1585	
D925	8-719-815-85	DIODE 1S1585	
D951	8-719-200-82	DIODE 11ES2	
D952	8-719-200-82	DIODE 11ES2	
D953	8-719-200-82	DIODE 11ES2	
D954	8-719-200-82	DIODE 11ES2	
< IC >			
IC901	8-759-604-86	IC M5F7807L	
< RESISTOR >			
R921	1-249-413-11	CARBON	470 5% 1/4W F
R922	1-249-417-11	CARBON	1K 5% 1/4W F
R925	1-259-416-11	CARBON	330 5% 1/6W
△R954	1-212-869-00	FUSIBLE	33 5% 1/4W F

*	1-669-370-11	POWER SW BOARD	*****
< CAPACITOR >			
△C991	1-113-916-11	CERAMIC	0.01uF 20% 250V
< CONNECTOR >			
CN994	1-690-123-21	REED (WITH CONNECTOR) (2 CORE)	
< SWITCH >			
S991	1-572-267-51	SWITCH, PUSH (AC POWER)(1 KEY)(POWER)	

*	1-670-212-11	ROTARY SW BOARD	*****
< RESISTOR >			
R852	1-249-415-11	CARBON	680 5% 1/4W F
R853	1-249-417-11	CARBON	1K 5% 1/4W F
R854	1-249-419-11	CARBON	1.5K 5% 1/4W F

The components identified by mark △ or dotted line with mark △ are critical for safety. Replace only with part number specified.

ROTARY SW

SERVO

Ref. No.	Part No.	Description	Remarks	Ref. No.	Part No.	Description	Remarks
		< SWITCH >					
S550	1-771-312-11	SWITCH, ROTARY (FILTER)		C173	1-163-021-91	CERAMIC CHIP 0.01uF	10% 50V
*****				C180	1-164-505-11	CERAMIC CHIP 2.2uF	16V
				C191	1-164-505-11	CERAMIC CHIP 2.2uF	16V
				C192	1-164-505-11	CERAMIC CHIP 2.2uF	16V
				C193	1-164-505-11	CERAMIC CHIP 2.2uF	16V
* A-4699-989-A		SERVO BOARD, COMPLETE		C194	1-164-505-11	CERAMIC CHIP 2.2uF	16V
*****				C261	1-124-584-00	ELECT 100uF	20% 10V
		< CAPACITOR >		C262	1-164-004-11	CERAMIC CHIP 0.1uF	10% 25V
C051	1-164-004-11	CERAMIC CHIP 0.1uF	10% 25V	C360	1-164-505-11	CERAMIC CHIP 2.2uF	16V
C061	1-164-004-11	CERAMIC CHIP 0.1uF	10% 25V	C371	1-164-505-11	CERAMIC CHIP 2.2uF	16V
C071	1-126-052-11	ELECT 100uF	20% 16V				
C072	1-164-004-11	CERAMIC CHIP 0.1uF	10% 25V	C372	1-104-913-11	TANTAL. CHIP 10uF	20% 16V
C073	1-164-505-11	CERAMIC CHIP 2.2uF	16V			< CONNECTOR >	
C101	1-163-133-00	CERAMIC CHIP 470PF	5% 50V	* CN101	1-568-867-11	SOCKET, CONNECTOR 25P	
C102	1-164-004-11	CERAMIC CHIP 0.1uF	10% 25V	CN102	1-563-932-11	CONNECTOR, F.P.C 21P	
C103	1-163-133-00	CERAMIC CHIP 470PF	5% 50V	* CN103	1-568-941-11	PIN, CONNECTOR 3P	
C104	1-163-133-00	CERAMIC CHIP 470PF	5% 50V	* CN108	1-564-518-11	PLUG, CONNECTOR 3P	
C105	1-119-779-11	ELECT 220uF	20% 10V	* CN109	1-564-518-11	PLUG, CONNECTOR 3P	
C106	1-164-505-11	CERAMIC CHIP 2.2uF	16V	CN112	1-506-481-11	PIN, CONNECTOR 2P	
C107	1-130-973-00	FILM 0.022uF	5% 63V	CN113	1-506-481-11	PIN, CONNECTOR 2P	
C108	1-163-809-11	CERAMIC CHIP 0.047uF	10% 25V			< DIODE >	
C109	1-163-145-00	CERAMIC CHIP 0.0015uF	5% 50V	D101	8-719-016-74	DIODE 1SS352	
C110	1-163-017-00	CERAMIC CHIP 0.0047uF	5% 50V	D361	8-719-938-07	DIODE GL480	
C111	1-163-021-91	CERAMIC CHIP 0.01uF	10% 50V			< IC >	
C112	1-164-004-11	CERAMIC CHIP 0.1uF	10% 25V	IC101	8-752-389-34	IC CXD2585Q	
C113	1-164-505-11	CERAMIC CHIP 2.2uF	16V	IC102	8-759-071-79	IC BA6297AFP	
C114	1-104-913-11	TANTAL. CHIP 10uF	20% 16V	IC103	8-752-085-51	IC CXA2568M	
C115	1-124-673-11	ELECT 100uF	20% 10V	IC104	8-759-048-30	IC LA6510L	
C116	1-124-673-11	ELECT 100uF	20% 10V	IC361	8-749-010-61	IC IS471F	
C117	1-104-848-11	TANTAL. CHIP 100uF	20% 4V			< COIL >	
C118	1-163-275-11	CERAMIC CHIP 0.001uF	5% 50V	L101	1-414-234-11	INDUCTOR CHIP 0uH	
C119	1-163-231-11	CERAMIC CHIP 15PF	5% 50V	L102	1-414-234-11	INDUCTOR CHIP 0uH	
C121	1-163-021-91	CERAMIC CHIP 0.01uF	10% 50V			< TRANSISTOR >	
C122	1-109-982-11	CERAMIC CHIP 1uF	10% 10V	Q101	8-729-010-08	TRANSISTOR MSB710-R	
C123	1-163-021-91	CERAMIC CHIP 0.01uF	10% 50V	Q102	8-729-010-08	TRANSISTOR MSB710-R	
C124	1-107-823-11	CERAMIC CHIP 0.47uF	10% 16V	Q301	8-729-424-08	TRANSISTOR UN2111	
C125	1-164-004-11	CERAMIC CHIP 0.1uF	10% 25V	Q302	8-729-421-22	TRANSISTOR UN2211	
C126	1-104-913-11	TANTAL. CHIP 10uF	20% 16V			< RESISTOR >	
C131	1-164-004-11	CERAMIC CHIP 0.1uF	10% 25V	R050	1-216-298-00	METAL CHIP 2.2	5% 1/10W
C132	1-164-004-11	CERAMIC CHIP 0.1uF	10% 25V	R051	1-216-298-00	METAL CHIP 2.2	5% 1/10W
C140	1-164-505-11	CERAMIC CHIP 2.2uF	16V	R052	1-216-298-00	METAL CHIP 2.2	5% 1/10W
C141	1-164-505-11	CERAMIC CHIP 2.2uF	16V	R053	1-216-298-00	METAL CHIP 2.2	5% 1/10W
C151	1-163-133-00	CERAMIC CHIP 470PF	5% 50V	R054	1-216-097-91	RES,CHIP 100K	5% 1/10W
C152	1-163-133-00	CERAMIC CHIP 470PF	5% 50V	R055	1-216-065-91	RES,CHIP 4.7K	5% 1/10W
C153	1-164-505-11	CERAMIC CHIP 2.2uF	16V	R056	1-216-101-00	METAL CHIP 150K	5% 1/10W
C154	1-164-505-11	CERAMIC CHIP 2.2uF	16V	R057	1-216-049-91	RES,CHIP 1K	5% 1/10W
C155	1-163-133-00	CERAMIC CHIP 470PF	5% 50V	R058	1-216-097-91	RES,CHIP 100K	5% 1/10W
C156	1-163-133-00	CERAMIC CHIP 470PF	5% 50V	R059	1-216-295-91	SHORT 0	
C157	1-163-023-00	CERAMIC CHIP 0.015uF	5% 50V	R060	1-216-298-00	METAL CHIP 2.2	5% 1/10W
C158	1-163-023-00	CERAMIC CHIP 0.015uF	5% 50V	R061	1-216-298-00	METAL CHIP 2.2	5% 1/10W
C159	1-163-019-00	CERAMIC CHIP 0.0068uF	10% 50V	R062	1-216-298-00	METAL CHIP 2.2	5% 1/10W
C160	1-164-695-11	CERAMIC CHIP 0.0022uF	5% 50V	R063	1-216-298-00	METAL CHIP 2.2	5% 1/10W
C161	1-164-505-11	CERAMIC CHIP 2.2uF	16V	R064	1-216-097-91	RES,CHIP 100K	5% 1/10W
C162	1-164-004-11	CERAMIC CHIP 0.1uF	10% 25V				
C163	1-104-913-11	TANTAL. CHIP 10uF	20% 16V				
C170	1-113-988-11	TANTAL. CHIP 68uF	20% 4V				
C171	1-163-133-00	CERAMIC CHIP 470PF	5% 50V				
C172	1-163-133-00	CERAMIC CHIP 470PF	5% 50V				

SERVO	SLED	SPINDLE	TRANS
-------	------	---------	-------

Ref. No.	Part No.	Description	Quantity	Resistor Value	Power	Remarks
R065	1-216-065-91	RES,CHIP	4.7K	5%	1/10W	
R066	1-216-101-00	METAL CHIP	150K	5%	1/10W	
R067	1-216-049-91	RES,CHIP	1K	5%	1/10W	
R068	1-216-097-91	RES,CHIP	100K	5%	1/10W	
R069	1-216-295-91	SHORT	0			
R071	1-216-073-00	METAL CHIP	10K	5%	1/10W	
R092	1-216-296-91	SHORT	0			
R101	1-216-077-00	METAL CHIP	15K	5%	1/10W	
R102	1-216-097-91	RES,CHIP	100K	5%	1/10W	
R103	1-216-077-00	METAL CHIP	15K	5%	1/10W	
R104	1-216-085-00	METAL CHIP	33K	5%	1/10W	
R105	1-216-097-91	RES,CHIP	100K	5%	1/10W	
R106	1-216-061-00	METAL CHIP	3.3K	5%	1/10W	
R107	1-216-061-00	METAL CHIP	3.3K	5%	1/10W	
R108	1-216-073-00	METAL CHIP	10K	5%	1/10W	
R109	1-216-121-91	RES,CHIP	1M	5%	1/10W	
R110	1-216-025-91	RES,CHIP	100	5%	1/10W	
R112	1-216-049-91	RES,CHIP	1K	5%	1/10W	
R113	1-216-073-00	METAL CHIP	10K	5%	1/10W	
R114	1-216-073-00	METAL CHIP	10K	5%	1/10W	
R117	1-216-073-00	METAL CHIP	10K	5%	1/10W	
R118	1-216-073-00	METAL CHIP	10K	5%	1/10W	
R121	1-216-073-00	METAL CHIP	10K	5%	1/10W	
R122	1-216-073-00	METAL CHIP	10K	5%	1/10W	
R123	1-216-073-00	METAL CHIP	10K	5%	1/10W	
R124	1-216-097-91	RES,CHIP	100K	5%	1/10W	
R125	1-216-037-00	METAL CHIP	330	5%	1/10W	
R126	1-216-037-00	METAL CHIP	330	5%	1/10W	
R127	1-216-037-00	METAL CHIP	330	5%	1/10W	
R131	1-216-037-00	METAL CHIP	330	5%	1/10W	
R133	1-216-049-91	RES,CHIP	1K	5%	1/10W	
R134	1-216-049-91	RES,CHIP	1K	5%	1/10W	
R135	1-216-295-91	SHORT	0			
R136	1-216-295-91	SHORT	0			
R137	1-216-295-91	SHORT	0			
R138	1-216-295-91	SHORT	0			
R143	1-216-103-00	METAL CHIP	180K	5%	1/10W	
R144	1-216-103-00	METAL CHIP	180K	5%	1/10W	
R145	1-216-069-00	METAL CHIP	6.8K	5%	1/10W	
R146	1-216-121-91	RES,CHIP	1M	5%	1/10W	
R147	1-216-081-00	METAL CHIP	22K	5%	1/10W	
R148	1-216-001-00	METAL CHIP	10	5%	1/10W	
R149	1-216-003-11	RES,CHIP	12	5%	1/10W	
R150	1-216-121-91	RES,CHIP	1M	5%	1/10W	
R151	1-216-073-00	METAL CHIP	10K	5%	1/10W	
R152	1-216-073-00	METAL CHIP	10K	5%	1/10W	
R153	1-216-073-00	METAL CHIP	10K	5%	1/10W	
R154	1-216-073-00	METAL CHIP	10K	5%	1/10W	
R155	1-216-073-00	METAL CHIP	10K	5%	1/10W	
R156	1-216-073-00	METAL CHIP	10K	5%	1/10W	
R157	1-216-105-91	RES,CHIP	220K	5%	1/10W	
R158	1-216-105-91	RES,CHIP	220K	5%	1/10W	
R159	1-216-101-00	METAL CHIP	150K	5%	1/10W	
R160	1-216-097-91	RES,CHIP	100K	5%	1/10W	
R162	1-216-113-00	METAL CHIP	470K	5%	1/10W	
R163	1-216-105-91	RES,CHIP	220K	5%	1/10W	
R168	1-216-295-91	SHORT	0			
R170	1-216-025-91	RES,CHIP	100	5%	1/10W	
R171	1-216-073-00	METAL CHIP	10K	5%	1/10W	
R172	1-216-073-00	METAL CHIP	10K	5%	1/10W	

Ref. No.	Part No.	Description	Quantity	Resistor Value	Power	Remarks
R173	1-216-073-00	METAL CHIP	10K	5%	1/10W	
R174	1-216-073-00	METAL CHIP	10K	5%	1/10W	
R175	1-216-073-00	METAL CHIP	10K	5%	1/10W	
R176	1-216-073-00	METAL CHIP	10K	5%	1/10W	
R177	1-216-025-91	RES,CHIP	100	5%	1/10W	
R180	1-216-049-91	RES,CHIP	1K	5%	1/10W	
R181	1-216-065-91	RES,CHIP	4.7K	5%	1/10W	
R182	1-216-065-91	RES,CHIP	4.7K	5%	1/10W	
R183	1-216-065-91	RES,CHIP	4.7K	5%	1/10W	
R184	1-216-065-91	RES,CHIP	4.7K	5%	1/10W	
R191	1-216-009-00	METAL CHIP	22	5%	1/10W	
R192	1-216-009-00	METAL CHIP	22	5%	1/10W	
R193	1-216-009-00	METAL CHIP	22	5%	1/10W	
R194	1-216-009-00	METAL CHIP	22	5%	1/10W	
R301	1-216-021-00	METAL CHIP	68	5%	1/10W	
R312	1-216-073-00	METAL CHIP	10K	5%	1/10W	
R359	1-216-089-91	RES,CHIP	47K	5%	1/10W	
R366	1-216-295-91	SHORT	0			
< SWITCH >						
S153	1-762-930-11	SWITCH, LEVER (LOAD OUT)				

*	1-658-709-11	SLED BOARD				

< CONNECTOR >						
CN104	1-774-380-11	CONNECTOR, FFC/FPC 16P				
CN105	1-568-838-11	SOCKET, CONNECTOR 21P				
* CN106	1-750-737-11	CONNECTOR, FFC/FPC 5P				
< MOTOR >						
M102		MOTOR ASSY (SLED)				

*	1-658-708-11	SPINDLE BOARD				

< CONNECTOR >						
* CN107	1-568-848-11	SOCKET, CONNECTOR 5P				
< MOTOR >						
M151	A-4660-968-A	MOTOR ASSY (LOADING)				
< SWITCH >						
S151	1-571-958-11	SWITCH, PUSH (1 KEY)(LIMIT)				

*	1-669-373-11	TRANS BOARD				

< CAPACITOR >						
△C992	1-113-916-11	CERAMIC	0.01uF	20%	250V	
△C993	1-102-106-00	CERAMIC	100PF	10%	50V	
△C994	1-113-916-11	CERAMIC	0.01uF	20%	250V	

The components identified by mark △ or dotted line with mark △ are critical for safety. Replace only with part number specified.

Ref. No.	Part No.	Description	Remarks	Ref. No.	Part No.	Description	Remarks
		< CONNECTOR >				ACCESSORIES & PACKING MATERIALS *****	
CN991	1-580-230-11	PIN, CONNECTOR (PC BOARD) 2P			1-452-873-11	MAGNET	
CN992	1-564-321-00	PIN, CONNECTOR 2P			1-473-720-11	REMOTE COMMANDER (RM-DX50)	
		< COIL >			1-590-925-31	CORD, CONNECTION	
△L901	1-424-485-11	FILTER, LINE			3-810-765-21	MANUAL, COMMONNESS INSTRUCTION (ENGLISH/FRENCH/GERMAN/SPANISH/DUTCH/ SWEDISH/ITALIAN/PORTUGUESE/CHINESE) (XB920E:SP, MY)	
		< RESISTOR >			3-810-765-72	MANUAL, COMMONNESS INSTRUCTION (ENGLISH/FRENCH/GERMAN/SPANISH/ITALIAN/PORTUGUESE) (XB920/XB920E:UK)	
△R991	1-249-413-11	CARBON 470 5% 1/4W F					

		MISCELLANEOUS *****					
△6	1-575-651-21	CORD, POWER			3-861-844-11	MANUAL, INSTRUCTION (ENGLISH/FRENCH/SPANISH) (XB920/XB920E:UK)	
△7	1-770-019-11	ADAPTOR, CONVERSION PLUG 3P(UK)			3-861-844-21	MANUAL, INSTRUCTION (GERMAN/DUTCH/SWEDISH/ITALIAN/PORTUGUESE) (XB920)	
105	1-773-145-11	WIRE (FLAT TYPE) (21 CORE)			3-861-844-31	MANUAL, INSTRUCTION (CHINESE) (XB920E:SP, MY)	
107	1-783-598-11	WIRE (FLAT TYPE) (25 CORE)			3-861-844-41	MANUAL, INSTRUCTION (ENGLISH/FRENCH/SPANISH) (XB920E:SP, MY)	
109	1-776-998-11	WIRE (FLAT TYPE) (21 CORE)					
257	1-775-990-11	WIRE (FLAT TYPE) (5 CORE)			4-983-956-01	COVER, BATTERY (for RM-DX50)	
△260	8-848-379-31	OPTICAL PICK-UP BLOCK KSS-213B/K-N			X-4950-254-1	STABILIZER ASSY	
261	1-775-991-11	WIRE (FLAT TYPE) (16 CORE)			*****	*****	
M151	A-4660-968-A	MOTOR ASSY (LOADING)				HARDWARE LIST	
M101	X-4950-461-1	MOTOR ASSY (SPINDLE)				*****	
M102	X-4947-303-1	MOTOR ASSY (SLED)					
△T901	1-431-902-11	TRANSFORMER, POWER			#1	7-685-646-79	SCREW +BVTP 3 × 8 TYPE2 N-S
		*****			#2	7-685-871-01	SCREW +BVTT 3 × 6 (S)
					#3	7-627-553-38	SCREW, PRECISION +P 2 × 3
					#4	7-627-852-07	SCREW, PRECISION +P 1.7 × 2.5
					#5	7-621-775-10	SCREW +B 2.6 × 4
					#6	7-685-885-09	SCREW +BVTT 4 × 16 (S)

The components identified by mark △ or dotted line with mark △ are critical for safety. Replace only with part number specified.

