

CDP-190/390

SERVICE MANUAL

US Model
AEP Model
E Model
Australian Model
 CDP-190 / 390
Canadian Model
 CDP-190



Photo : CDP-190

Model Name Using Similar Mechanism	NEW
CD Mechanism Name	CDM14-5BD1
Base Unit Name	BU-5BD1

SPECIFICATIONS

Compact disc player

Frequency response	2 Hz - 20 kHz ± 1.0 dB
Signal to noise ratio	More than 93 dB
Dynamic range	More than 90 dB
Harmonic distortion	Less than 0.05 %
Channel separation	More than 90 dB

Outputs

LINE OUT (phono jacks)	Output level 2 V (at 50 kilohms) Load impedance over 10 kilohms
------------------------	--

PHONES

(stereo phone jack)	Output level max. 10mW Load impedance 32 ohms
---------------------	--

General

Power requirements	US, Canadian model : 120V AC, 60Hz AEP model : 220V AC, 50/60Hz E, Australian model : 110, 120, 220 or 240V AC adjustable, 50/60Hz
--------------------	---

Power consumption 8W

Dimensions 430×100×280mm (w/h/d)
(approx, including projections)

Weight (approx) 3kg

Supplied accessories

	CDP-390	CDP-190
AC power cord	1	
Audio cord	1 (2 phono plugs - 2 phono plugs)	
Remote commander	1	—
Sony SUM-3(NS) batteries	2	—

Remote commander	(RM-D90)
Remote control system	Infrared control
Power requirements	3 V DC with two R6 (size AA) batteries
Dimensions	Approx. 43 × 20 × 175 mm (w/h/d) (1 3/4 × 1 1/16 × 7 inches)
Weight	Approx. 100 g (3.6 oz) Including batteries

Design and specifications subject to change without notice.

COMPACT DISC PLAYER
SONY®



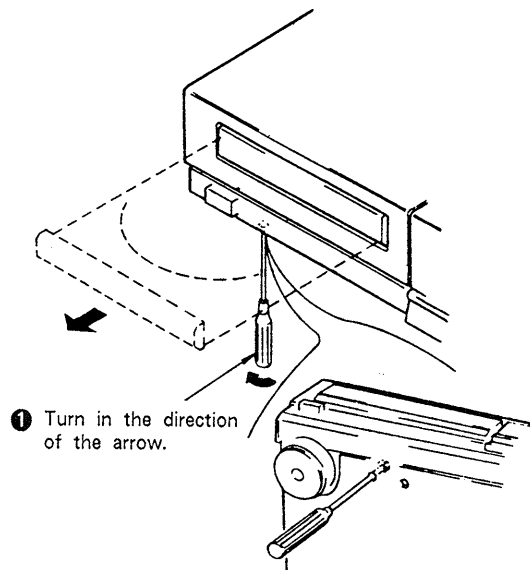

TABLE OF CONTENTS

<u>Section</u>	<u>Title</u>	<u>Page</u>
SECTION 1. GENERAL		
1-1.	Location and Function of Controls.....	5
SECTION 2. DISASSEMBLY 6		
SECTION 3. ELECTRICAL ADJUSTMENTS 7		
SECTION 4. DIAGRAMS		
4-1.	Block Diagram	9
4-2.	Printed Wiring Boards.....	12
4-3.	Schematic Diagram	15
4-4.	IC101 (CXA1372Q) Pin Descriptions.....	18
4-5.	IC Block Diagram.....	19
SECTION 5. EXPLODED VIEWS21		
SECTION 6. ELECTRICAL PARTS LIST24		

HOW TO OPEN THE DISC TRAY WHEN
POWER SWITCH TURNS OFF

Caution : When you work, keep the set horizontal.

SAFETY-RELATED COMPONENT WARNING!!

COMPONENTS IDENTIFIED BY MARK  OR DOTTED LINE WITH MARK  ON THE SCHEMATIC DIAGRAMS AND IN THE PARTS LIST ARE CRITICAL TO SAFE OPERATION. REPLACE THESE COMPONENTS WITH SONY PARTS WHOSE PART NUMBERS APPEAR AS SHOWN IN THIS MANUAL OR IN SUPPLEMENTS PUBLISHED BY SONY.

ATTENTION AU COMPOSANT AYANT RAPPORT
À LA SÉCURITÉ!

LES COMPOSANTS IDENTIFIÉS PAR UNE MARQUE  SUR LES DIAGRAMMES SCHÉMATIQUES ET LA LISTE DES PIÈCES SONT CRITIQUES POUR LA SÉCURITÉ DE FONCTIONNEMENT. NE REMPLACER CES COMPOSANTS QUE PAR DES PIÈCES SONY DONT LES NUMÉROS SONT DONNÉS DANS CE MANUEL OU DANS LES SUPPLÉMENTS PUBLIÉS PAR SONY.

MODEL IDENTIFICATION

-Specification Labels-

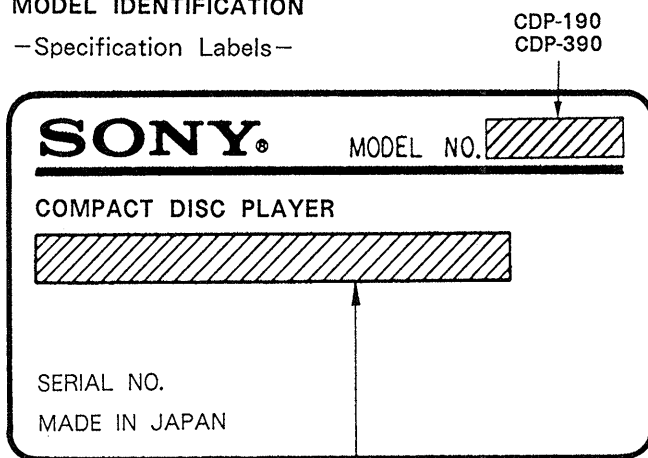

US, Canadian model : AC : 120V 60Hz 8W

AEP model : AC : 220V~50/60Hz 8W

E, Australian model : AC : 110V-120V, 220-240V
~50/60Hz 8W
NOTES ON HANDLING THE OPTICAL PICK-UP BLOCK OR BASE UNIT

The laser diode in the optical pick-up block may suffer electrostatic breakdown because of the potential difference generated by the charged electrostatic load, etc. on clothing and the human body.

During repair, pay attention to electrostatic breakdown and also use the procedure in the printed matter which is included in the repair parts.

The flexible board is easily damaged and should be handled with care.

NOTES ON LASER DIODE EMISSION CHECK

The laser beam on this model is concentrated so as to be focused on the disc reflective surface by the objective lens in the optical pick-up block. Therefore, when checking the laser diode emission, observe more than 25 cm away from the objective lens.

SAFETY CHECK-OUT

After correcting the original service problem, perform the following safety check before releasing the set to the customer:

Check the antenna terminals, metal trim, "metallized" knobs, screws, and all other exposed metal parts for AC leakage. Check leakage as described below.

LEAKAGE TEST

The AC leakage from any exposed metal part to earth ground and from all exposed metal parts to any exposed metal part having a return to chassis, must not exceed 0.5 mA (500 microamperes). Leakage current can be measured by any one of three methods.

1. A commercial leakage tester, such as the Simpson 229 or RCA WT-540A. Follow the manufacturers' instructions to use these instruments.
2. A battery-operated AC milliammeter. The Data Precision 245 digital multimeter is suitable for this job.
3. Measuring the voltage drop across a resistor by means of a VOM or battery-operated AC voltmeter. The "limit" indication is 0.75 V, so analog meters must have an accurate low-voltage scale. The Simpson 250 and Sanwa SH-63Trd are examples of a passive VOM that is suitable. Nearly all battery operated digital multimeters that have a 2V AC range are suitable. (See Fig. A)

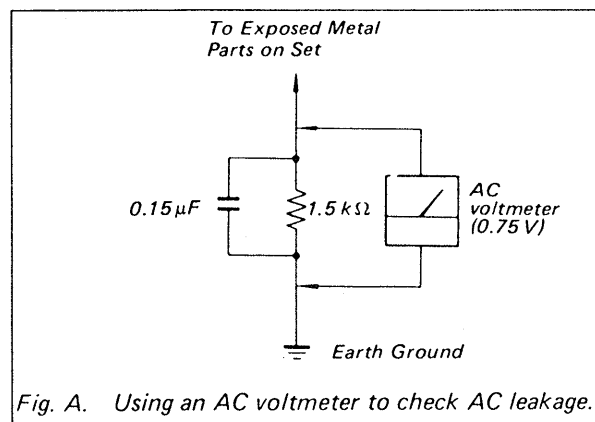

Fig. A. Using an AC voltmeter to check AC leakage.

PROTECTION OF EYES FROM LASER BEAM DURING SERVICING

This set employs a laser. Therefore, be sure to follow carefully the instructions below when servicing.

CAUTION

Use of controls or adjustments or performance of procedures other than those specified herein may result in hazardous radiation exposure.

1. Laser Diode Properties

- Material: GaAlAs
- Wavelength: 780 nm
- Emission Duration: continuous
- Laser Output: max. 44.6 μ W*

* This output is the value measured at a distance of about 200 mm from the objective lens surface on the Optical Pick-up Block.

2. During service, do not take the Optical Pick-up Block apart, and do not adjust the APC circuit. If there is a breakdown in the APC circuit (including laser diode), replace the entire Optical Pick-up Block (including APC board).

BESKYTTELSE AF ØJNE MOD LASERSTRÅLING UNDER SERVICE

I dette apparat anvendes laserlys. Derfor skal nedenstående instruktioner nøje følges under service.

Følg iøvrigt instruktionerne i servicemanualen.

ADVARSEL!!

Under service må øjnene ikke komme nær objektiv-linsen på den optiske pick-up enhed. I tilfælde af at det er nødvendigt at kontrollere udsendelsen af laserlys, skal det ske i en afstand af mere end 25 cm fra den optiske pick-up.

1. Laser-dioe data

- Materiale: GaAlAs
- Bølgelængde: 780 nm
- Udstråling: Kontinuerlig
- Laseroutput: Max. 0,4 mW*

* Målt i 1,6 mm afstand fra overfladen af objektiv-linsen på den optiske pick-up enhed.

- Klassifikation: Klasse IIIb.

2. Adskil aldrig den optiske pick-up enhed under service, og juster ikke APC kredsløbet (Automatic Power Control). Hvis APC kredsløbet (incl. laserdioden) bryder ned, skal hele den optiske pick-up enhed (incl. APC printkortet) udskiftes.

LASER ADVARSEL MÆRKNING

Følgende mærkning findes indvendig i apparatet:

1. Advarsel Mærkning

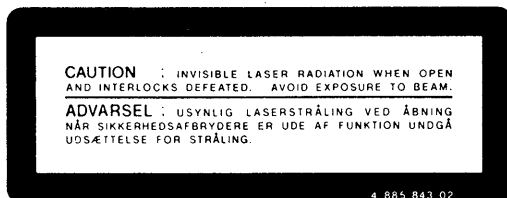

VAROITUS: Laite sisältää, laserdiodin, joka lähettää (näkyvätöntä) silmille vaarallista lasersäteilyä.

SECTION 1 GENERAL

1-1. LOCATION AND FUNCTION OF CONTROLS

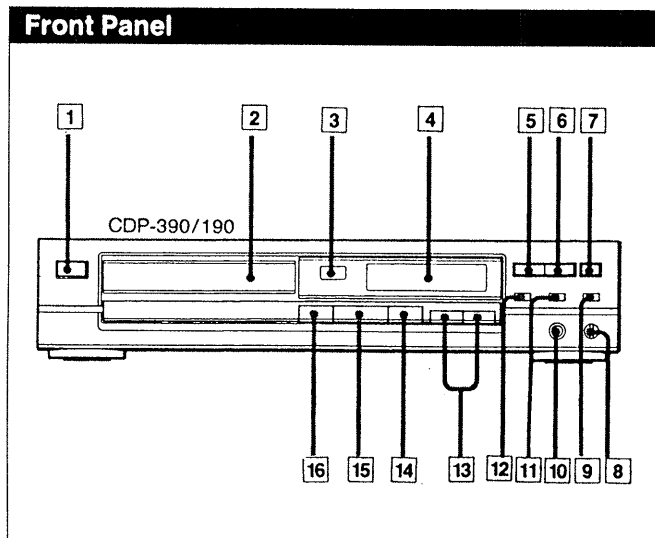

- 1 POWER switch
- 2 Disc tray
- 3 Remote sensor
- 4 Display window
- 5 PROGRAM button
- 6 SHUFFLE button
- 7 REPEAT button
- 8 (headphone) LEVEL control
- 9 MUSIC SCAN button
- 10 PHONES (headphones) jack
- 11 FADER button
- 12 TIME button
- 13 ◀◀▶▶ (AMS*/RMS**)/▶▶▶▶ (manual search) buttons
- 14 ■ (stop)/PGM (program) CLEAR button
- 15 ▶▶ (play/pause) button
- 16 ▲ OPEN/CLOSE button

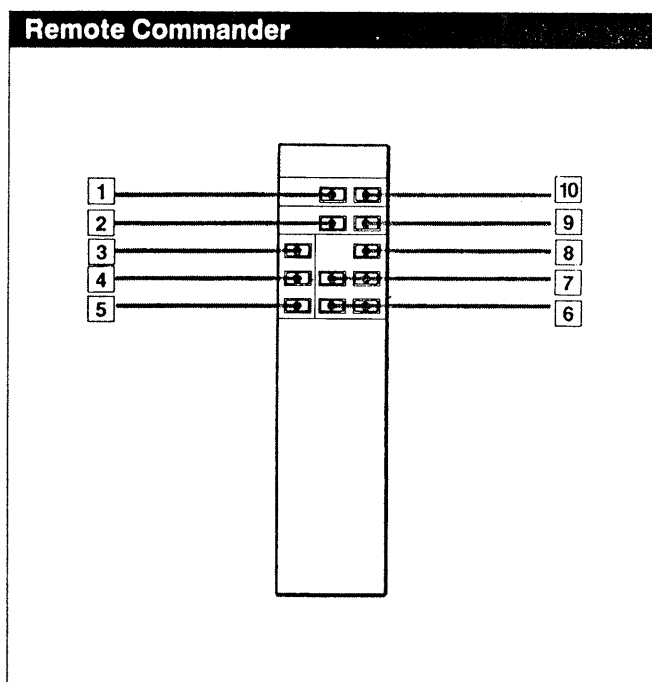

- 1 PGM (program) button
- 2 TIME button
- 3 ▶ (play) button
- 4 || (pause) button
- 5 ■ (stop) button
- 6 ◀◀▶▶ (manual search) buttons
- 7 ◀◀▶▶ (AMS*) buttons
- 8 FADER button
- 9 REPEAT button
- 10 SHUFFLE button

*AMS is the abbreviation of Automatic Music Sensor.

**RMS is the abbreviation of Random Music Sensor.

SECTION 2 DISSASSEMBLY OF BASE UNIT

Note: Follow the disassembly procedure in the numerical order given.

1. Remove CD mechanism from the set and turn over.
2. Turn the cam in the Arrow **A** direction by the **⊖** driver.
3. Take out disc table.
4. Remove bracket yoke.
5. Remove BU-5BD1 in the Arrow **4** direction.

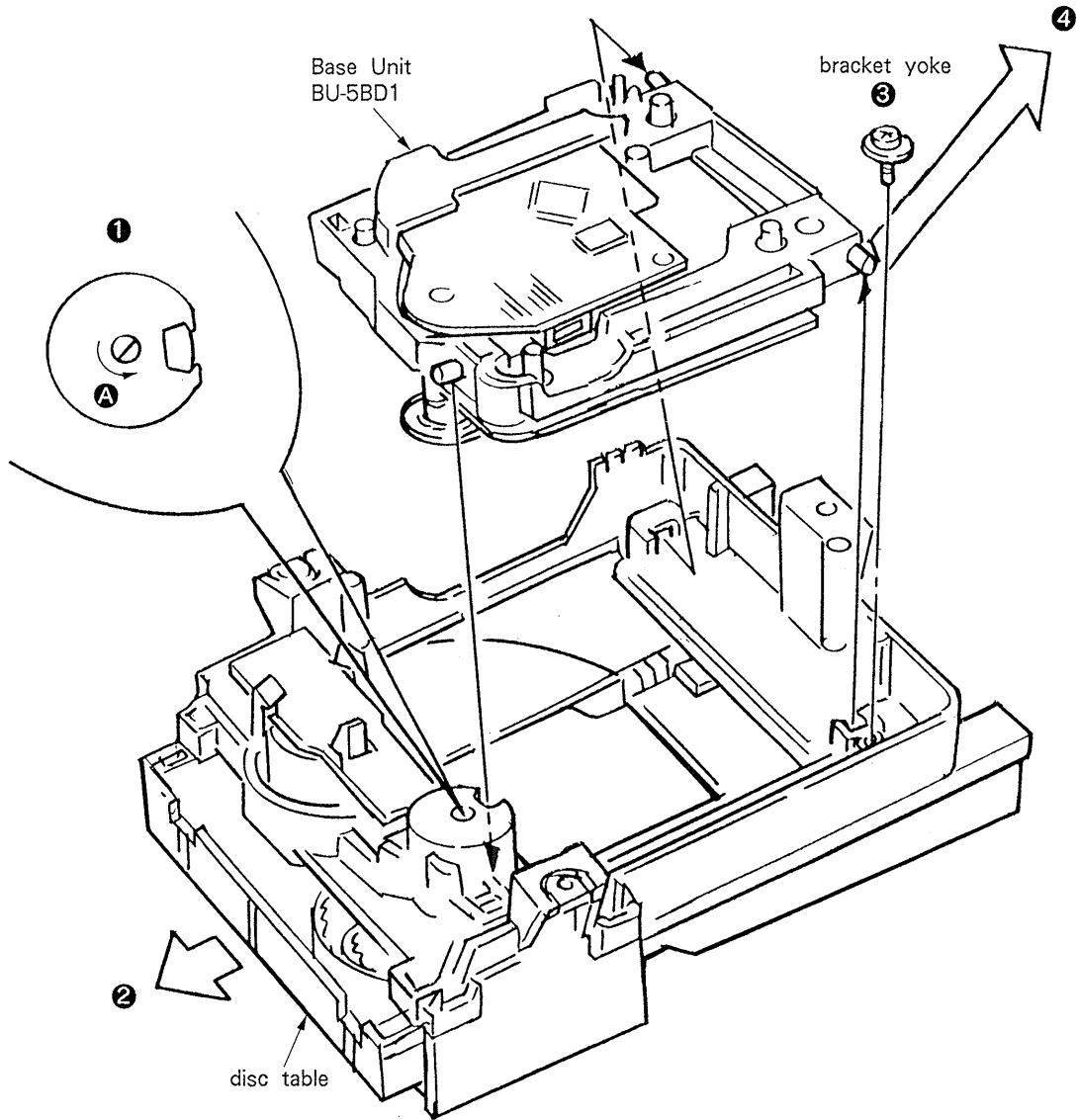

SECTION 3

ELECTRICAL ADJUSTMENTS

1. Perform adjustments in the order given.
2. Use YEDS-18 disc (3-702-101-1) unless otherwise indicated.
3. Use the oscilloscope with more than 10 MΩ impedance.

RF Level Check

Procedure :

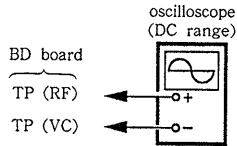

1. Connect oscilloscope to test point TP (RF) and TP (VC) on BD board.
2. Confirm that RF level and eye pattern is optimum. Optimum eye pattern means that shape "◇" can be clearly distinguished at the center of the wave form.

RF Signal Reference Waveform (eye pattern)

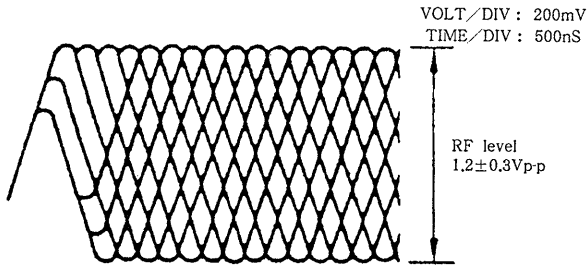

REFERENCE

E-F Balance Check

Procedure :

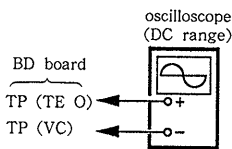

1. Connect test point TP (ADJ) and TP (TES) to ground with lead wire.
2. Connect oscilloscope to test point TP (TE O) and TP (VC) on BD board.
3. Turn POWER switch on.
4. Put disc (YEDS-18) in and playback.
5. Confirm that the oscilloscope waveform is symmetrical on the top and bottom in relation to 0V.
6. After check, remove the lead wire connected in step 1.

Note : Take sweep time as long as possible to obtain best waveform.

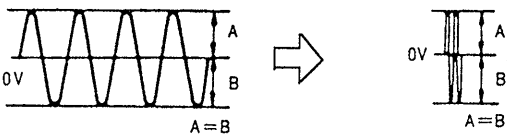

RF PLL Free-run Frequency Check

Procedure :

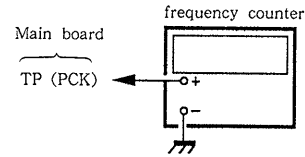

1. Turn POWER switch on.
2. Put disc (YEDS-18) in and playback.
3. Confirm that reading on frequency counter is 4,3218MHz.

Focus/Tracking Gain Adjustment

A frequency response analyzer is necessary in order to perform this adjustment exactly.

However, this gain has a margin, so even if it is slightly off, there is no problem. Therefore, do not perform this adjustment.

Focus/tracking gain determines the pick-up follow-up (vertical and horizontal) relative to mechanical noise and mechanical shock when the 2-axis device operate.

However, as these reciprocate, the adjustment is at the point where both are satisfied.

- When gain is raised, the noise when the 2-axis device operates increases.
- When gain is lowered, mechanical shock and skipping occurs more easily.
- When gain adjustment is off, the symptoms below appear.

Symptoms	Gain	Focus	Tracking
• The time until music starts becomes longer for STOP → ▷PLAY or automatic selection. (⏮, ⏭ buttons pressed.) (Normally takes about 1 seconds.)		low	low or high
• Music does not start and disc continues to rotate for STOP → ▷PLAY or automatic selection. (⏮, ⏭ buttons pressed.)		-	low
• Sound is interrupted during PLAY. Or time counter display stops progressing.		-	low
• More noise during 2-axis device operation.		high	high

The following is a simple adjustment method.

-Primary Adjustment-

Note : Since exact adjustment cannot be performed, remember the positions of the controls before performing the adjustment.

If the positions after the primary adjustment are only a little different, return the controls to the original position.

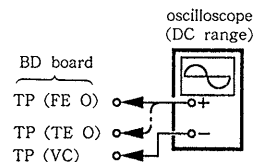

Procedure :

1. Keep the set horizontal.
(If the set is not horizontal, this adjustment cannot be performed due to the gravity against the 2-axis device.)
2. Insert disc (YEDS-18) and press ▷ PLAY button.
3. Connect oscilloscope to TP (FEO) and TP (VC) on BD board.
4. Adjustment RV102 on digital board so that the waveform is as shown in the figure below. (focus gain adjustment)

high tracking gain
(high fundamental wave)
than for low gain

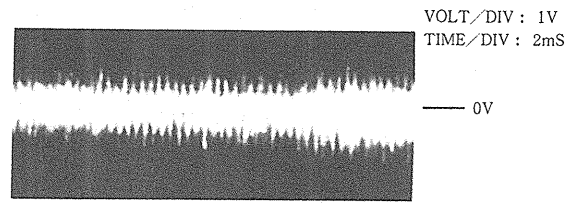

VOLT/DIV : 100mV
TIME/DIV : 2mS

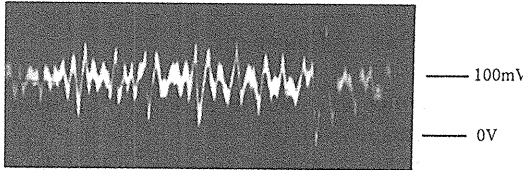

Adjustment Location :
[BD board]

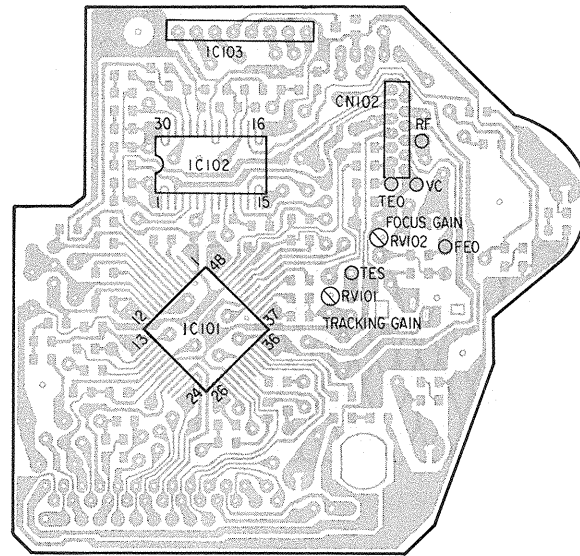

• Inccrrent Examples (DC level changes more than on adjusted waveform)

VOLT/DIV : 100mV
TIME/DIV : 2mS

low focus gain

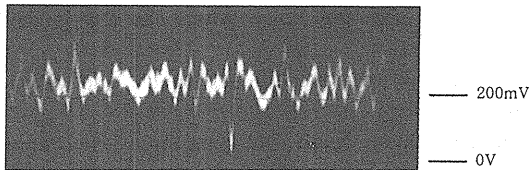

VOLT/DIV : 100mV
TIME/DIV : 2mS

high focus gain

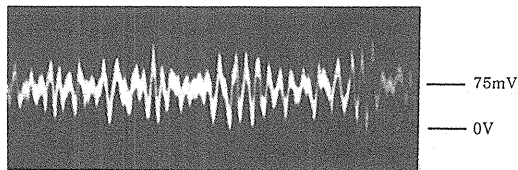

[Main board]

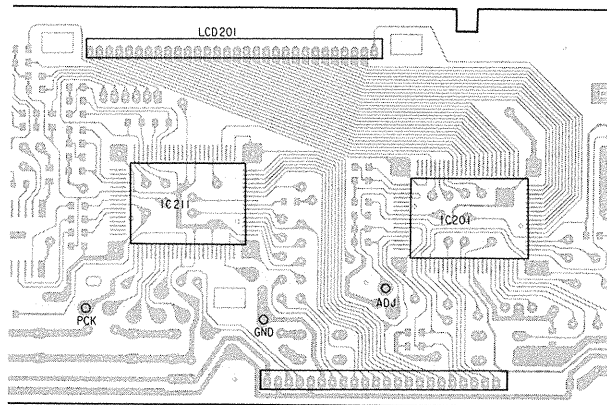

5. Connect oscilloscope to TP (TEO) and TP (VC) on BD board.
6. Adjust RV101 on digital board so that the waveform is as shown the figure below. (tracking gain adjustment)

VOLT/DIV : 1V
TIME/DIV : 2mS

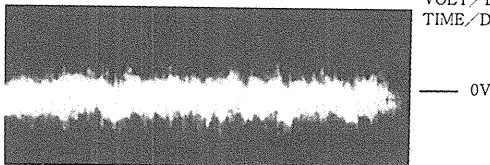

• Incorrect Examples (fundamental wave appears)

low tracking gain

VOLT/DIV : 1V
TIME/DIV : 2mS

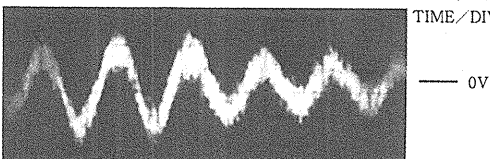

SECTION 4 DIAGRAMS

4-1. BLOCK DIAGRAM

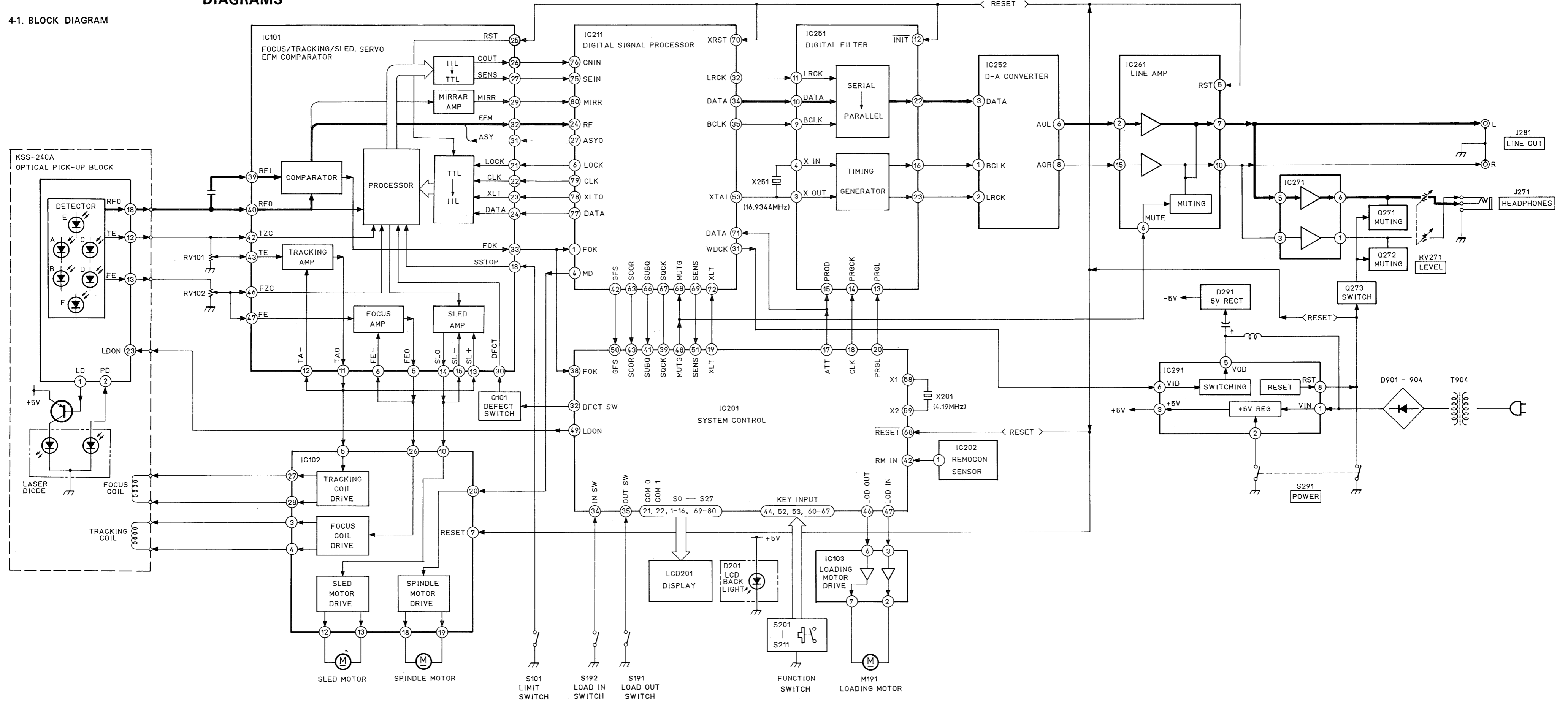

● SEMICONDUCTOR LEAD LAYOUTS

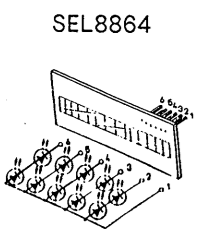
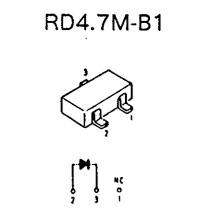
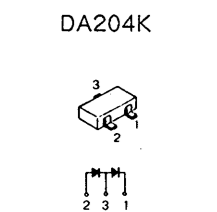
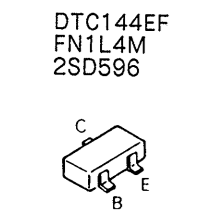
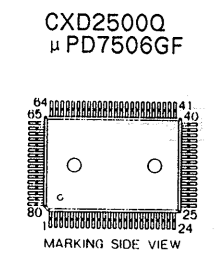
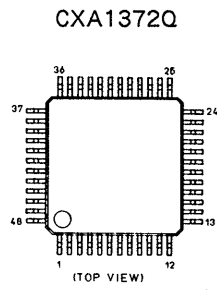

● SEMICONDUCTOR LOCATION

Ref. No	Location
IC101	C-13
IC102	B-13
IC103	B-13
IC201	C-8
IC202	C-9
IC211	C-6
IC251	D-5
IC252	C-4
IC261	C-4
IC271	C-2
IC291	C-3
Q101	D-13
Q251	B-4
Q271	C-1
Q272	C-1
Q273	C-2
D101	A-14
D201	C-5
D291	B-3
D901	H-11
D902	H-11
D903	H-11
D904	H-11

Note :

- : parts mounted on the conductor side.
- : Through hole.
- : Pattern on the side which is seen.
- ▨ : Pattern of the rear side.
- EA : Saudi Arabia
- AUS : Australian

4-2. PRINTED WIRING BOARDS

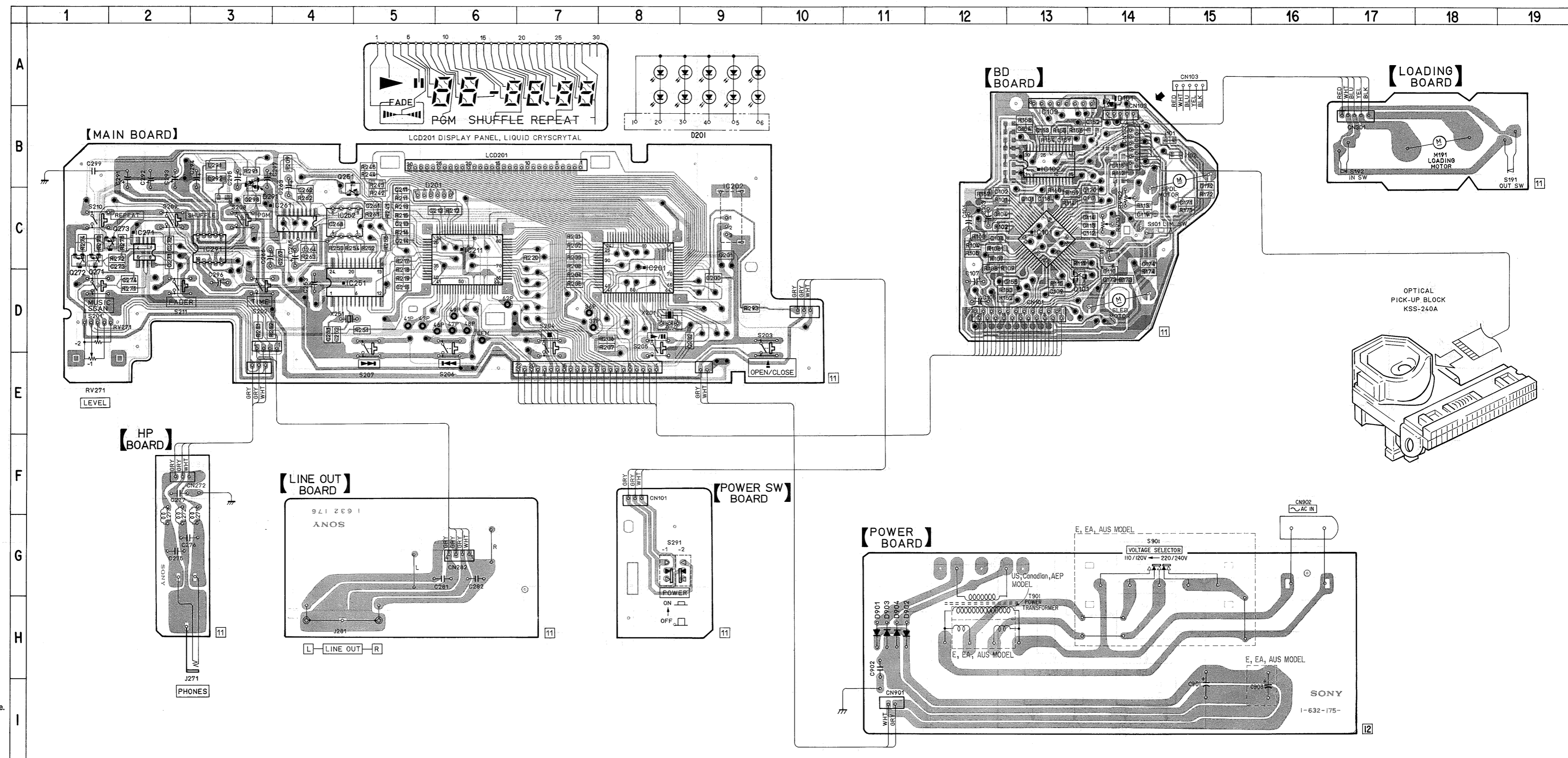

Note :

- All capacitors are in μF unless otherwise noted. μF : μF 50WV or less are not indicated except for electrolytics and tantalums.
- All resistors are in Ω and $\frac{1}{4}W$ or less unless otherwise specified.
- Δ : internal component.

Note:
The components identified by mark Δ or dotted line with mark Δ are critical for safety. Replace only with part number specified.

Note:
Les composants identifiés par une marque Δ sont critiques pour la sécurité. Ne les remplacer que par une pièce portant le numéro spécifié.

- B+** : B+ Line
- B-** : B- Line
- \square : adjustment for repair.

- Voltage and waveforms are dc with respect to ground under no-signal (detuned) conditions.
- no mark : PLAY
- () : STOP
- Voltagés are taken with a VOM (input impedance 10M Ω). Voltage variations may be noted due to normal production tolerances.
- Waveforms are taken with an oscilloscope. Voltage variations may be noted due to normal production tolerances.
- Circled numbers refer to waveforms.
- Signal path.
- \Rightarrow : CD
- EA : Saudi Arabia
- AUS : Australian

● WAVEFORM

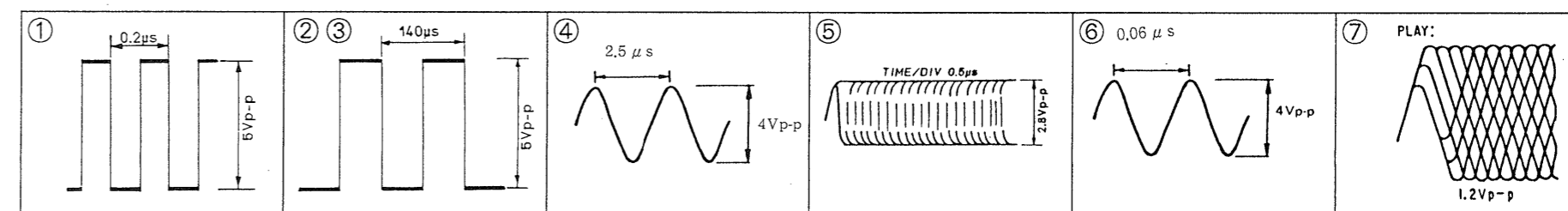

4-3. SCHEMATIC DIAGRAM

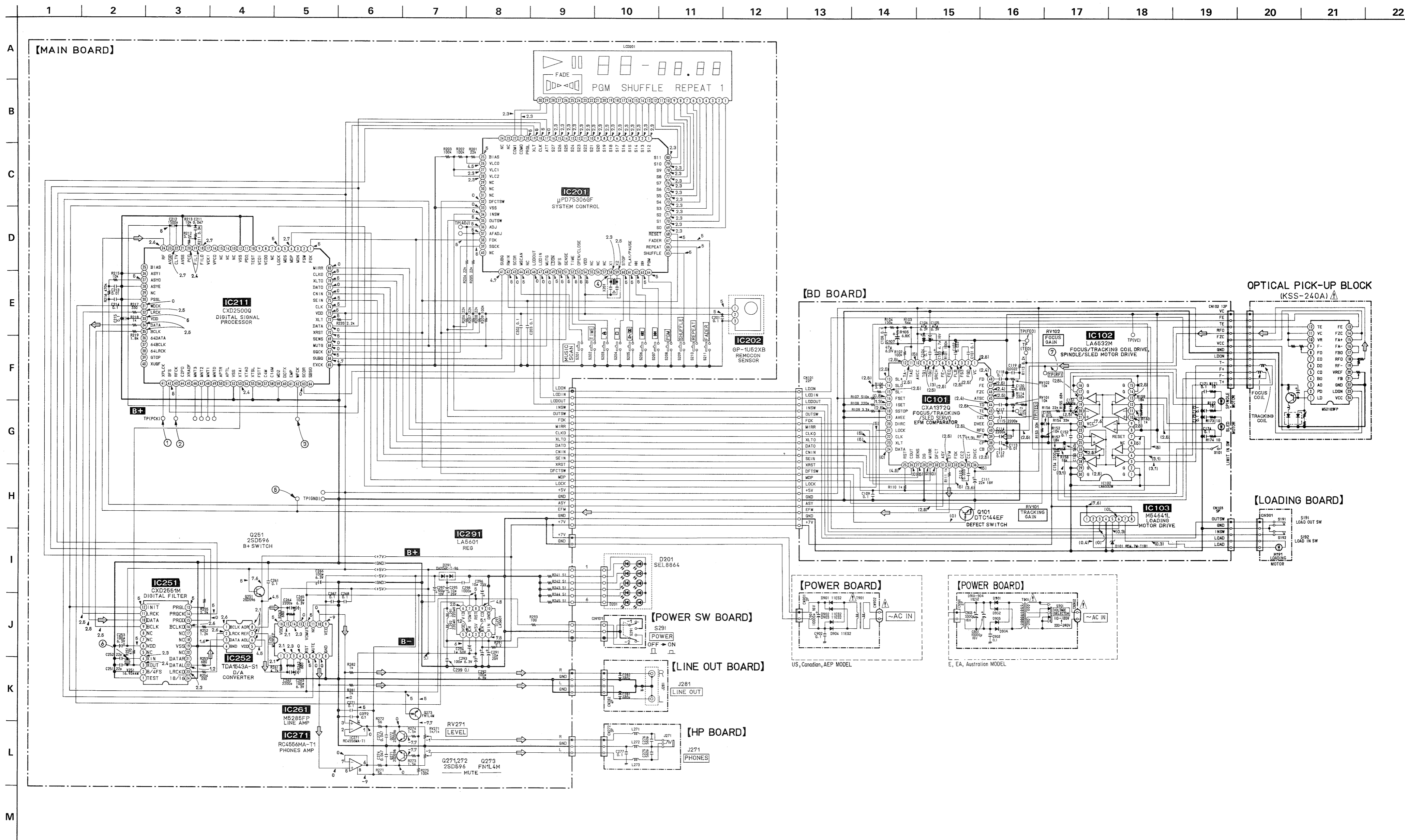

4-4. IC101 (CXA1372Q) PIN DESCRIPTIONS

PIN NO.	PIN NAME	I/O	FUNCTION
1	VC		2.5 Volts power supply.
2	FGD	I	Focus gain adjusting capacitor connected between ② pin and ③ pin.
3	FS3	I	Focus gain adjusting capacitor connected between ② pin and ③ pin.
4	FLB	I	Focus Servo low frequency boost-up capacitor connected.
5	FEO	O	Focus drive output.
6	FE-	I	Focus error amp inverted input.
7	SRCH	I	Connected capacitor to making the focus serch waveform.
8	TGU	I	Tracking gain adjusting capacitor connected between ⑧ pin and ⑨ pin.
9	TG2	I	Tracking gain adjusting capacitor connected between ⑧ pin and ⑨ pin.
10	AV CC		+5 Volts power supply.
11	TAO	O	Tracking drive output.
12	TA-	I	Tracking amp inverted input.
13	SL+	I	Sled amp non-inverted input.
14	SLO	O	Sled drive output.
15	SL-	I	Sled amp non-inverted input.
16	FSET	I	Phase stabilizer setting resistor connected.
17	ISET	I	Current setting resistor connected.
18	SSTOP	I	Limit switch connection port.
19	AV EE		Ground (0V).
20	DIRC	I	Direct control port. Non-connected.
21	LOCK	I	Sled free-run protection is operate at "L".
22	CLK	I	Serial data transmission clock input form digital signal processor.
23	XLT	I	Latch input from digital signal processor.
24	DATA	I	Serial input from digital signal processor.
25	XRST	I	System reset input, Reset at "L".
26	C. OUT	O	Tracking counter output.
27	SENS	O	Outputs internal state corresponding to address.
28	D GND		Digitel ground. Grounded
29	MIRR	O	Mirror output digital signal processor.
30	DFCT	O	Deffect output. Deffect at "H".
31	ASY	I	Auto symmetry control input.
32	EFM	O	EFM Comparator output.
33	FOK	O	Focus OK.
34	CC2	I	Deffect bottom hold input.
35	CC1	O	Deffect bottom hold output.
36	DV CC		+5 Volts power supply.
37	CB	I	Deffect bottom hold capacitor connected.
38	CP	I	Mirror hold capacitor connected.
39	RFI	I	RF Signal input (Capacitance coupled).
40	RFO	I	RF Signal input (Direct Coupled).
41	DV EE		Grounded (0V).
42	TZC	I	Tracking Zero-cross comparator input.
43	TE	I	Tracking error amp input.
44	TDFCT	I	Deffect correction hold capacitor connected.
45	ATSC	I	Anti-shock input.
46	FZC	I	Focus Zero-cross comparator input.
47	FE	I	Focus error input.
48	DFCT	I	Deffect correction hold capacitor connected.

4-5. IC BLOCK DIAGRAM

TDA1543

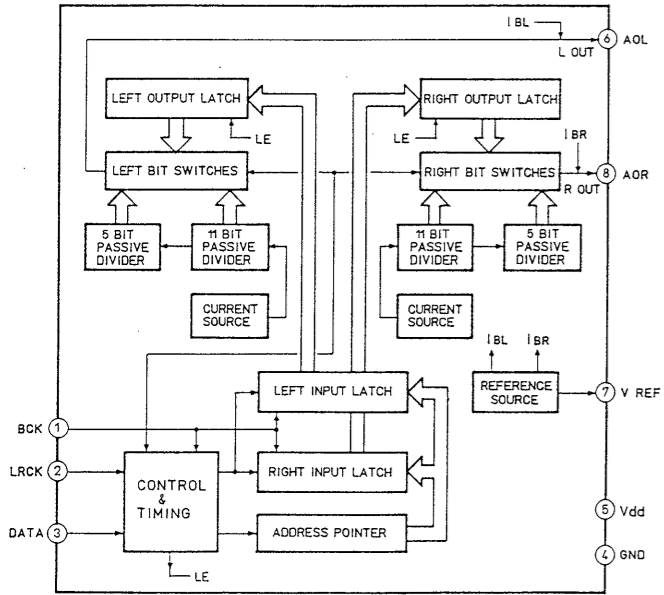

M54641L

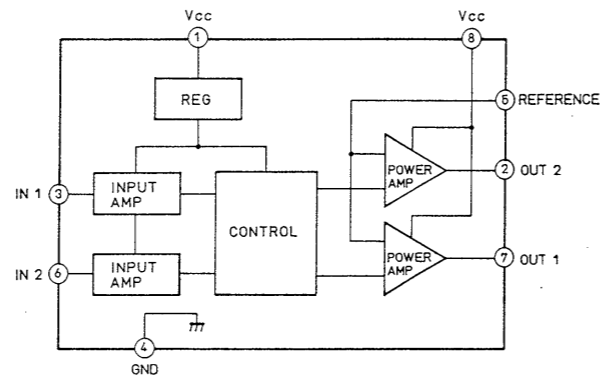

LA5601

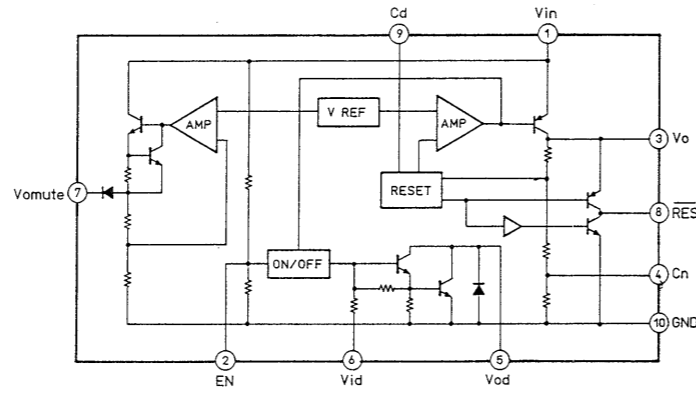

LA6532

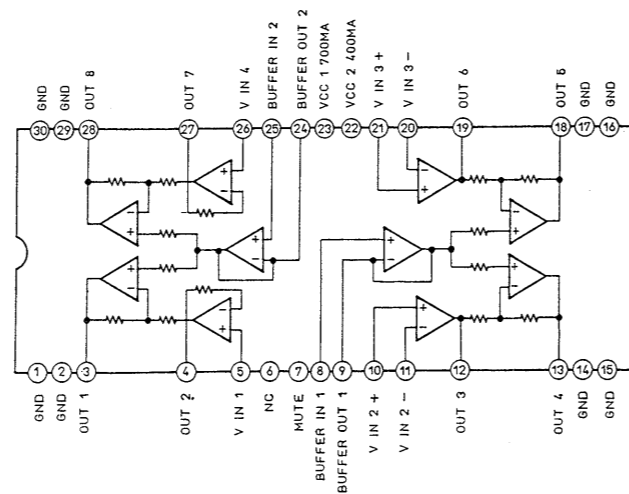

CXD2551M

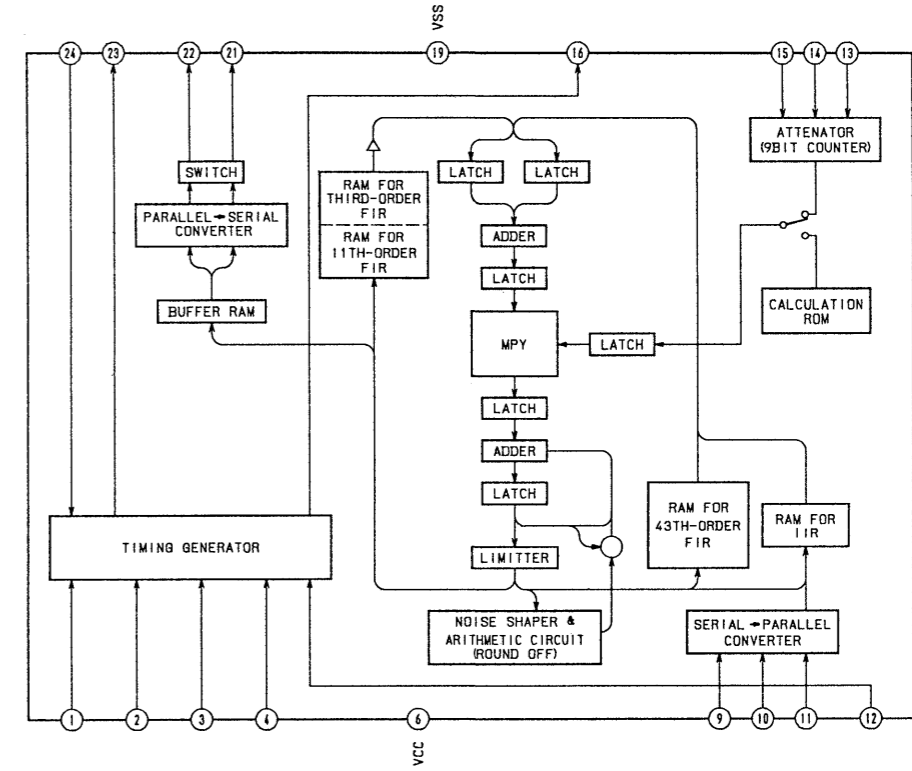

CXD2500

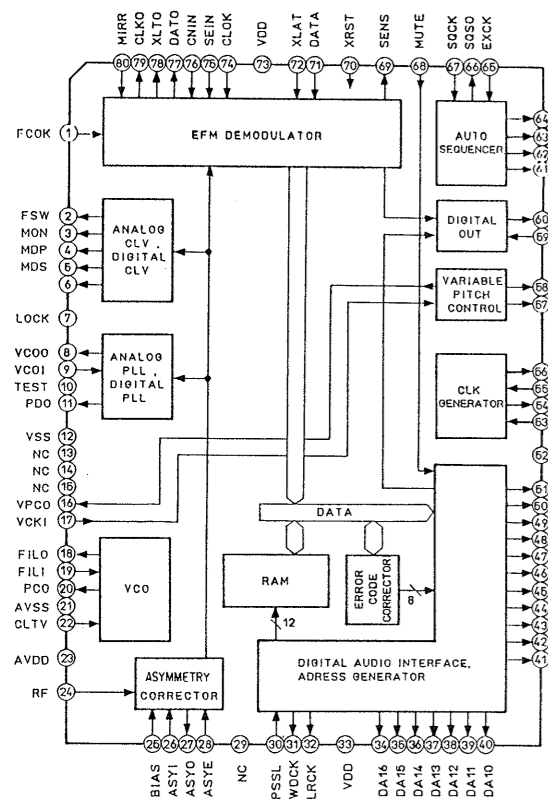

M5285FP

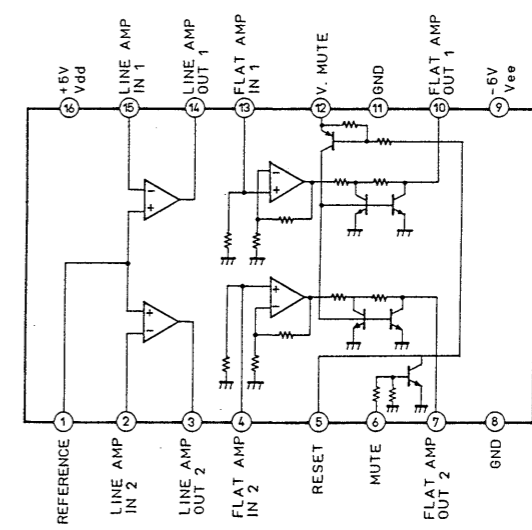

SECTION 5 EXPLODED VIEWS

NOTE:

- The mechanical parts with no reference number in the exploded views are not supplied.
- The construction parts of an assembled part are indicated with a collation number in the remark column.
- Items marked "★" are not stocked since they are seldom required for routine service. Some delay should be anticipated when ordering these items.

- Due to standardization, parts with part number suffix -XX and -X may be different from the parts specified in the components used on the set.
- Color Indication of Appearance Parts
Example:
(RED) ... KNOB, BALANCE (WHITE)

↑ Cabinet's Color

↑ Parts' Color

- EA : Saudi Arabia
- AUS : Australian

The components identified by mark or dotted line with mark are critical for safety. Replace only with part number specified.

Les composants identifiés par une marque sont critiques pour la sécurité. Ne les remplacer que par une pièce portant le numéro spécifié.

(1) CHASSIS SECTION

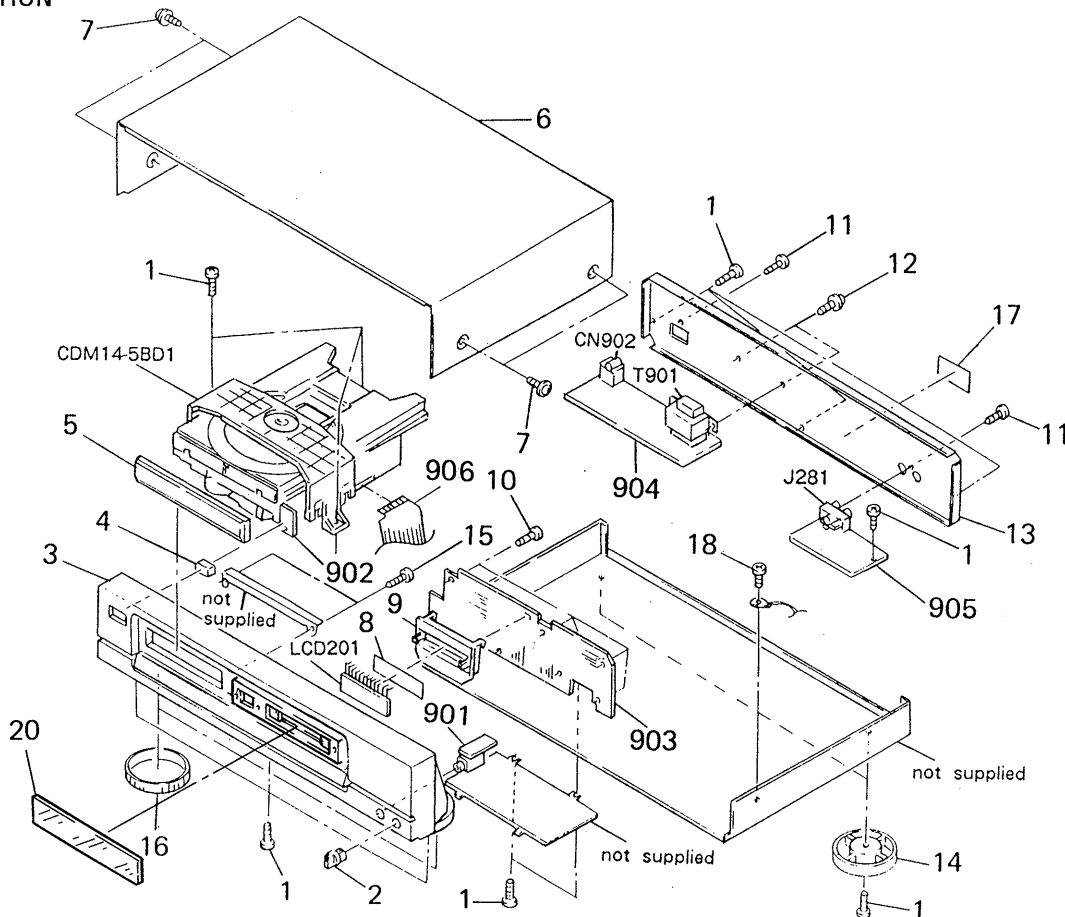

No.	Part No.	Description	Remarks	No.	Part No.	Description	Remarks
1	7-685-872-09	SCREW +BVTT 3X8 (S)		14	X-4885-950-1	(US,Canadian)...FOOT ASSY	
2	4-933-116-11	KNOB (C, TYPE), LOV			X-3304-938-2	(AEP,E,EA,AUS)...FOOT ASSY	
3	X-4933-101-1	(390:AEP,E,EA,AUS)...PANEL ASSY, FRONT		15	7-685-134-19	SCREW +BTP 2.6X8 TYPE2 N-S	
	X-4933-102-1	(390:US).....PANEL ASSY, FRONT		16	4-933-135-01	(AEP,E,EA,AUS)...RING (DIA.58A) ORNAMENTAL	
	X-4933-103-4	(190:US,Canadian)...PANEL ASSY, FRONT		17	*4-885-838-00	(AEP,E,EA,AUS)...LABEL, CLASS1	
	X-4933-104-1	(190:AEP,E,EA,AUS)...PANEL ASSY, FRONT		18	7-682-547-04	SCREW +BVTT 3X6 (S)	
4	4-922-921-01	BUTTON (POWER)		19	4-860-518-00	CUSHION	
5	4-933-117-01	(190:US,Canadian,AEP)...PANEL, LOADING		20	4-933-119-01	(190)...PLATE, INDICATION	
	4-933-117-11	(390:E,EA,AUS).....PANEL, LOADING			4-933-119-11	(390)...PLATE, INDICATION	
6	4-929-035-31	CASE		901	*1-632-622-11	PC BOARD, HP	
7	3-704-366-31	SCREW (CASE) (M3X6)		902	*1-632-174-11	PC BOARD, POWER SW	
8	*4-933-114-01	ILLUMINATOR		903	*A-4617-160-A	MOUNTED PCB, MAIN	
9	*4-933-121-01	HOLDER (LCD)		904	*1-632-175-11	PC BOARD, POWER	
10	4-928-635-01	SCREW, +BV (2.6X8) TAPPING		905	*1-632-176-11	PC BOARD, LINE OUT	
11	7-685-646-79	SCREW +BVTP 3X8 TYPE2 N-S		906	1-535-798-11	JUMPER, FILM (WITH TERMINAL)	
12	4-820-330-31	SCREW M4S		CN902	1-526-929-11	(E).....INLET, AC	
13	*4-933-101-01	(190:US).....PANEL, BACK		CN902	1-526-930-11	(US,Canadian)...INLET, AC	
	*4-933-101-11	(190:Canadian)...PANEL, BACK		CN902	1-526-931-11	(AEP,EA,AUS)....INLET, AC	
	*4-933-101-21	(190:AEP).....PANEL, BACK		J281	1-566-921-11	JACK, PIN 2P (LINE OUT)	
	*4-933-101-51	(190:E,EA).....PANEL, BACK		LCD201	1-808-794-11	DISPLAY PANEL, LIQUID CRYSTAL	
	*4-933-101-71	(190:AUS).....PANEL, BACK		T901	1-449-824-11	(US,Canadian)...TRANSFORMER, POWER	
	*4-933-102-01	(390:US).....PANEL, BACK		T901	1-449-825-11	(AEP).....TRANSFORMER, POWER	
	*4-933-102-21	(390:AEP).....PANEL, BACK		T901	1-450-011-11	(E,EA,AUS).....TRANSFORMER, POWER	
	*4-933-102-51	(390:E,EA).....PANEL, BACK					
	*4-933-102-71	(390:AUS).....PANEL, BACK					

(2) CD MECHANISM SECTION (CDM14-5BD1)

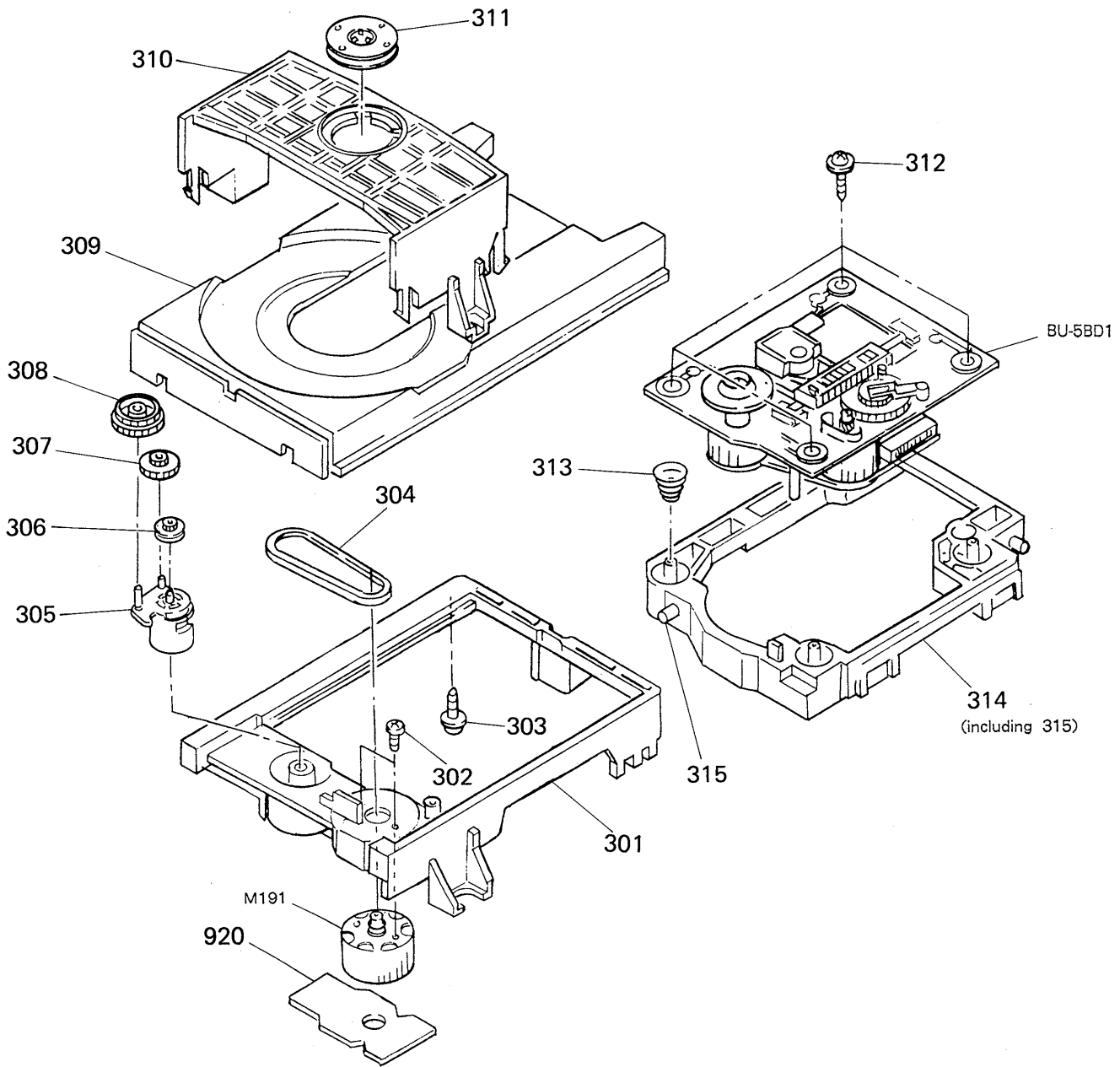

No.	Part No.	Description	Remarks	No.	Part No.	Description	Remarks
301	4-933-111-01	CHASSIS (MD)		310	4-933-110-01	HOLDER (MG)	
302	7-621-775-10	SCREW +B 2.6X4		311	A-4675-347-A	MG ASSY	
303	*4-917-583-21	BRACKET, YOKE		312	4-933-134-01	SCREW (+PTPWH M2.6X6)	
304	4-927-649-01	BELT		313	4-917-541-01	SPRING (B)	
305	4-933-109-01	CAM		314	4-933-129-01	HOLDER (BU)	
306	4-927-651-01	PULLEY (S)		315	4-933-108-01	SHAFT (CAM)	
307	4-927-628-01	GEAR (C)		920	*1-632-202-11	PC BOARD, LOADING	
308	4-933-107-01	GEAR (PL)		M191	A-4604-363-A	MOTOR (L) ASSY	
309	4-933-112-01	TABLE, DISK					

(3) OPTICAL PICK-UP BLOCK (BU-5BD1)

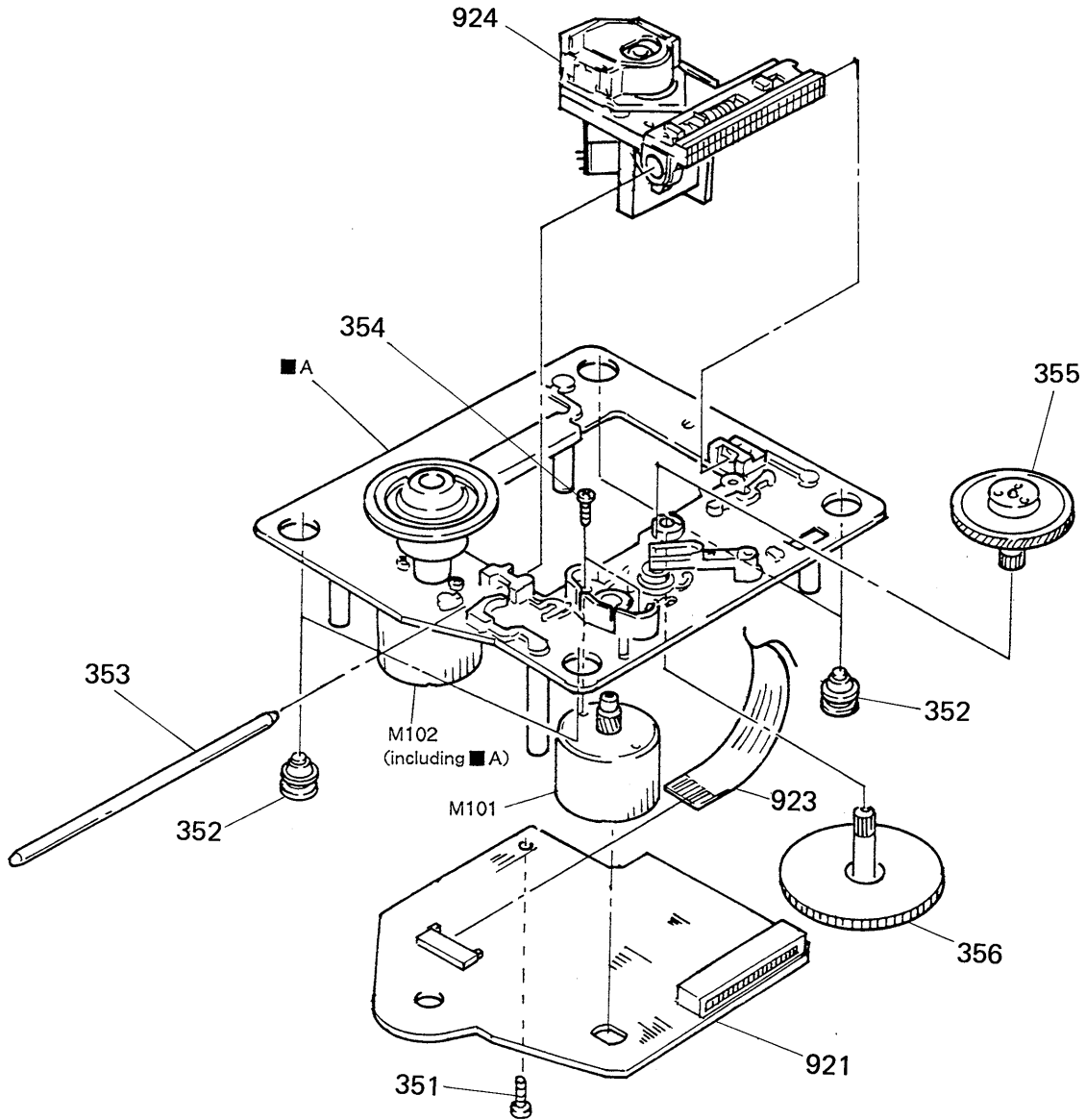

<p>Note: The components identified by mark \triangle or dotted line with mark \triangle are critical for safety. Replace only with part number specified.</p>	<p>Note: Les composants identifiés par une marque \triangle sont critiques pour la sécurité. Ne les remplacer que par une pièce portant le numéro spécifié.</p>
--	---

No.	Part No.	Description	Remarks	No.	Part No.	Description	Remarks
351	7-685-134-19	SCREW +BTP 2.6X8 TYPE2 N-S		921	*A-4617-161-A	MOUNTED PCB, BD	
352	4-933-126-01	INSULATOR (A)		923	1-575-001-11	WIRE, FLAT TYPE (12 CORE)	
353	4-917-565-01	SHAFT, SLED		924	\triangle 8-848-144-11	DEVICE, OPTICAL KSS-240A	
354	7-621-255-15	SCREW +P 2X3		M101	X-4917-504-1	ASSY, MOTOR (SLED)	
355	4-917-567-01	GEAR (M)		M102	X-4917-523-1	ASSY, MOTOR (SPINDLE)	
356	4-917-564-01	GEAR (P), FLATNESS					

SECTION 6 ELECTRICAL PARTS LIST

NOTE:

- Due to standardization, replacements in the parts list may be different from the parts specified in the diagrams or the components used on the set.
- Items marked "*" are not stocked since they are seldom required for routine service. Some delay should be anticipated when ordering these items.
- If there are two or more same circuits in a set such as a stereophonic machine, only typical circuit parts may be indicated and capacitors and resistors in other same circuits may be omitted.

CAPACITORS:

MF: μ F, PF: μ MF.

RESISTORS

- All resistors are in ohms.
- F: nonflammable

COILS

- MMH: mH, UH: μ H

SEMICONDUCTORS

In each case, U: μ , for example:

UA...: μ A..., UPA...: μ PA...,
UPC...: μ PC, UPD...: μ PD...

- EA : Saudi Arabia
- AUS : Australian

The components identified by mark Δ or dotted line with mark Δ are critical for safety. Replace only with part number specified.

Les composants identifiés par une marque Δ sont critiques pour la sécurité. Ne les remplacer que par une pièce portant le numéro spécifié.

Ref.No.	Part No.	Description		
901	*1-632-622-11	PC BOARD, HP		
902	*1-632-174-11	PC BOARD, POWER SW		
903	*A-4617-160-A	MOUNTED PCB, MAIN		
904	*1-632-175-11	PC BOARD, POWER		
905	*1-632-176-11	PC BOARD, LINE OUT		
906	1-535-798-11	JUMPER, FILM (WITH TERMINAL)		
920	*1-632-202-11	PC BOARD, LOADING		
921	*A-4617-161-A	MOUNTED PCB, BD		
923	1-575-001-11	WIRE, FLAT TYPE (12 CORE)		
924	Δ 8-848-144-11	DEVICE, OPTICAL KSS-240A		
C101	1-163-038-00	CERAMIC CHIP 0.1MF	25V	
C102	1-163-989-11	CERAMIC CHIP 0.033MF	10%	25V
C103	1-126-094-11	ELECT 4.7MF	20%	16V
C104	1-163-038-00	CERAMIC CHIP 0.1MF	25V	
C105	1-126-154-11	ELECT 47MF	20%	6.3V
C106	1-126-154-11	ELECT 47MF	20%	6.3V
C107	1-126-154-11	ELECT 47MF	20%	6.3V
C108	1-163-038-00	CERAMIC CHIP 0.1MF	25V	
C109	1-163-038-00	CERAMIC CHIP 0.1MF	25V	
C110	1-163-989-11	CERAMIC CHIP 0.033MF	10%	25V
C111	1-131-367-00	TANTALUM 22MF	20%	16V
C112	1-164-232-11	CERAMIC CHIP 0.01MF	10%	50V
C113	1-164-232-11	CERAMIC CHIP 0.01MF	10%	50V
C114	1-164-161-11	CERAMIC CHIP 0.0022MF	10%	50V
C115	1-164-161-11	CERAMIC CHIP 0.0022MF	10%	50V
C117	1-163-038-00	CERAMIC CHIP 0.1MF	25V	
C118	1-163-038-00	CERAMIC CHIP 0.1MF	25V	
C119	1-164-161-11	CERAMIC CHIP 0.0022MF	10%	50V
C120	1-163-989-11	CERAMIC CHIP 0.033MF	10%	25V
C151	1-163-019-00	CERAMIC CHIP 0.0068MF	10%	50V
C152	1-163-038-00	CERAMIC CHIP 0.1MF	25V	
C153	1-163-135-00	CERAMIC CHIP 560PF	10%	50V
C154	1-164-161-11	CERAMIC CHIP 0.0022MF	10%	50V
C155	1-163-023-00	CERAMIC CHIP 0.015MF	10%	50V
C171	1-163-038-00	CERAMIC CHIP 0.1MF	25V	
C172	1-163-038-00	CERAMIC CHIP 0.1MF	25V	
C173	1-163-038-00	CERAMIC CHIP 0.1MF	25V	
C174	1-163-038-00	CERAMIC CHIP 0.1MF	25V	
C201	1-163-038-00	CERAMIC CHIP 0.1MF	25V	
C202	1-163-038-00	CERAMIC CHIP 0.1MF	25V	
C203	1-163-038-00	CERAMIC CHIP 0.1MF	25V	
C211	1-163-809-11	CERAMIC CHIP 0.047MF	10%	25V
C212	1-163-011-11	CERAMIC CHIP 0.0015MF	10%	50V
C213	1-164-232-11	CERAMIC CHIP 0.01MF	50V	
C214	1-163-038-00	CERAMIC CHIP 0.1MF	25V	
C215	1-163-038-00	CERAMIC CHIP 0.1MF	25V	

Ref.No.	Part No.	Description		
C251	1-163-101-00	CERAMIC CHIP 22PF	5%	50V
C252	1-163-101-00	CERAMIC CHIP 22PF	5%	50V
C253	1-124-225-00	ELECT 100MF	20%	6.3V
C261	1-163-038-00	CERAMIC CHIP 0.1MF		25V
C262	1-164-161-11	CERAMIC CHIP 0.0022MF	10%	50V
C263	1-124-225-00	ELECT 100MF	20%	6.3V
C264	1-164-161-11	CERAMIC CHIP 0.0022MF	10%	50V
C265	1-124-225-00	ELECT 100MF	20%	6.3V
C266	1-124-225-00	ELECT 100MF	20%	6.3V
C267	1-163-038-00	CERAMIC CHIP 0.1MF		25V
C268	1-163-038-00	CERAMIC CHIP 0.1MF		25V
C271	1-163-038-00	CERAMIC CHIP 0.1MF		25V
C272	1-163-038-00	CERAMIC CHIP 0.1MF		25V
C273	1-163-035-00	CERAMIC CHIP 0.047MF		50V
C274	1-163-035-00	CERAMIC CHIP 0.047MF		50V
C275	1-130-468-00	MYLAR 560PF	5%	50V
C276	1-130-468-00	MYLAR 560PF	5%	50V
C277	1-162-851-11	CERAMIC 0.1MF	20%	16V
C281	1-130-469-00	MYLAR 680PF	5%	50V
C282	1-130-469-00	MYLAR 680PF	5%	50V
C291	1-126-096-11	ELECT 10MF	20%	25V
C292	1-124-225-00	ELECT 100MF	20%	6.3V
C293	1-124-225-00	ELECT 100MF	20%	6.3V
C294	1-126-160-11	ELECT 1MF	20%	50V
C295	1-126-096-11	ELECT 10MF	20%	25V
C296	1-126-096-11	ELECT 10MF	20%	25V
C297	1-124-584-00	ELECT 100MF	20%	10V
C298	1-163-009-11	CERAMIC CHIP 0.001MF	10%	50V
C299	1-164-159-11	CERAMIC 0.1MF		50V
C901	1-126-939-11	ELECT 10000MF	20%	16V
C902	1-162-851-11	CERAMIC 0.1MF	20%	16V
C903	1-124-887-00	(E,EA,AUS)...ELECT 3300MF	20%	16V
CN101	1-568-796-11	SOCKET, CONNECTOR 22P		
CN102	1-568-795-11	SOCKET, CONNECTOR 12P		
CN103	*1-564-721-11	PIN, CONNECTOR (SMALL TYPE) 5P		
CN272	*1-564-496-11	PIN, CONNECTOR 3P		
CN282	*1-564-706-11	PIN, CONNECTOR (SMALL TYPE) 4P		
CN301	*1-564-707-11	PIN, CONNECTOR (SMALL TYPE) 5P		
CN901	*1-564-336-00	PIN, CONNECTOR 2P		
CN902 Δ	1-526-929-11	(E).....INLET, AC		
CN902 Δ	1-526-930-11	(US,Canadian)...INLET, AC		
CN902 Δ	1-526-931-11	(AEP,EA,AUS)...INLET, AC		
D101	8-719-105-72	DIODE RD4.7M-B1		
D201	1-808-805-11	DIODE SEL8864		
D291	8-719-403-80	DIODE MA157		

Ref.No.	Part No.	Description	Ref.No.	Part No.	Description
D901	8-719-200-82	DIODE 11ES2	R113	1-216-071-00	METAL GLAZE 8.2K 5% 1/10W
D902	8-719-200-82	DIODE 11ES2	R114	1-216-105-00	METAL GLAZE 220K 5% 1/10W
D903	8-719-200-82	DIODE 11ES2	R152	1-216-073-00	METAL GLAZE 10K 5% 1/10W
D904	8-719-200-82	DIODE 11ES2			
IC101	8-752-037-33	IC CXA1372Q	R153	1-216-085-00	METAL GLAZE 33K 5% 1/10W
IC102	8-759-821-94	IC LA6532M	R154	1-216-085-00	METAL GLAZE 33K 5% 1/10W
IC103	8-759-633-65	IC M54641L	R155	1-216-093-00	METAL GLAZE 68K 5% 1/10W
IC201	8-759-146-34	IC UPD75308GF-403-3B9	R156	1-216-081-00	METAL GLAZE 22K 5% 1/10W
IC202	8-749-920-83	IC GPIU52XB	R157	1-216-079-00	METAL GLAZE 18K 5% 1/10W
IC211	8-752-333-31	IC CXD2500Q	R158	1-216-079-00	METAL GLAZE 18K 5% 1/10W
IC251	8-752-334-07	IC CXD2551M	R159	1-216-079-00	METAL GLAZE 18K 5% 1/10W
IC252	8-759-990-13	IC TDA1543A-S1	R160	1-216-049-00	METAL GLAZE 1K 5% 1/10W
IC261	8-759-633-66	IC M5285FP	R171	1-216-001-00	METAL GLAZE 10 5% 1/10W
IC271	8-759-981-86	IC RC4556MA	R172	1-216-001-00	METAL GLAZE 10 5% 1/10W
IC291	8-759-821-93	IC LA5601	R173	1-216-001-00	METAL GLAZE 10 5% 1/10W
J101	1-216-295-00	METAL GLAZE 0 5% 1/10W	R174	1-216-001-00	METAL GLAZE 10 5% 1/10W
J102	1-216-295-00	METAL GLAZE 0 5% 1/10W	R201	1-216-081-00	METAL GLAZE 22K 5% 1/10W
J271	1-568-519-21	JACK, LARGE TYPE (PHONES)	R202	1-216-097-00	METAL GLAZE 100K 5% 1/10W
J281	1-566-921-11	JACK, PIN 2P (LINE OUT)	R203	1-216-097-00	METAL GLAZE 100K 5% 1/10W
L271	1-424-090-11	COIL, LINE FILTER	R204	1-216-081-00	METAL GLAZE 22K 5% 1/10W
L272	1-424-090-11	COIL, LINE FILTER	R205	1-216-081-00	METAL GLAZE 22K 5% 1/10W
L273	1-424-090-11	COIL, LINE FILTER	R206	1-216-081-00	METAL GLAZE 22K 5% 1/10W
L291	1-410-658-31	INDUCTOR CHIP 220UH	R207	1-216-081-00	METAL GLAZE 22K 5% 1/10W
L292	1-410-658-31	INDUCTOR CHIP 220UH	R208	1-216-081-00	METAL GLAZE 22K 5% 1/10W
LCD201	1-808-794-11	DISPLAY PANEL, LIQUID CRYSTAL	R209	1-216-097-00	METAL GLAZE 100K 5% 1/10W
M101	X-4917-504-1	ASSY, MOTOR (SLED)	R211	1-216-061-00	METAL GLAZE 3.3K 5% 1/10W
M102	X-4917-523-1	ASSY, MOTOR (SPINDLE)	R212	1-216-061-00	METAL GLAZE 3.3K 5% 1/10W
M191	A-4604-363-A	MOTOR (L) ASSY	R213	1-216-073-00	METAL GLAZE 10K 5% 1/10W
Q101	8-729-901-01	TRANSISTOR DTC144EK	R215	1-216-073-00	METAL GLAZE 10K 5% 1/10W
Q251	8-729-159-64	TRANSISTOR 2SD596	R216	1-216-113-00	METAL GLAZE 470K 5% 1/10W
Q271	8-729-159-64	TRANSISTOR 2SD596	R217	1-216-037-00	METAL GLAZE 330 5% 1/10W
Q272	8-729-159-64	TRANSISTOR 2SD596	R218	1-216-049-00	METAL GLAZE 1K 5% 1/10W
Q273	8-729-113-66	TRANSISTOR FN1L4M-M31	R219	1-216-055-00	METAL GLAZE 1.8K 5% 1/10W
R101	1-216-097-00	METAL GLAZE 100K 5% 1/10W	R220	1-216-057-00	METAL GLAZE 2.2K 5% 1/10W
R102	1-216-097-00	METAL GLAZE 100K 5% 1/10W	R241	1-216-018-00	METAL GLAZE 51 5% 1/10W
R103	1-216-091-00	METAL GLAZE 56K 5% 1/10W	R242	1-216-018-00	METAL GLAZE 51 5% 1/10W
R104	1-216-099-00	METAL GLAZE 120K 5% 1/10W	R243	1-216-018-00	METAL GLAZE 51 5% 1/10W
R105	1-216-069-00	METAL GLAZE 6.8K 5% 1/10W	R244	1-216-018-00	METAL GLAZE 51 5% 1/10W
R106	1-216-061-00	METAL GLAZE 3.3K 5% 1/10W	R251	1-216-041-00	METAL GLAZE 470 5% 1/10W
R107	1-216-114-00	METAL GLAZE 510K 5% 1/10W	R252	1-216-051-00	METAL GLAZE 1.2K 5% 1/10W
R108	1-216-105-00	METAL GLAZE 220K 5% 1/10W	R253	1-216-045-00	METAL GLAZE 680 5% 1/10W
R109	1-216-073-00	METAL GLAZE 10K 5% 1/10W	R254	1-216-037-00	METAL GLAZE 330 5% 1/10W
R110	1-216-049-00	METAL GLAZE 1K 5% 1/10W	R255	1-216-057-00	METAL GLAZE 2.2K 5% 1/10W
R111	1-216-049-00	METAL GLAZE 1K 5% 1/10W	R261	1-216-065-00	METAL GLAZE 4.7K 5% 1/10W
R112	1-216-085-00	METAL GLAZE 27K 5% 1/10W	R262	1-216-045-00	METAL GLAZE 680 5% 1/10W

Ref.No.	Part No.	Description
R263	1-216-045-00	METAL GLAZE 680 5% 1/10W
R271	1-216-019-00	METAL GLAZE 56 5% 1/10W
R272	1-216-019-00	METAL GLAZE 56 5% 1/10W
R273	1-216-053-00	METAL GLAZE 1.5K 5% 1/10W
R274	1-216-053-00	METAL GLAZE 1.5K 5% 1/10W
R275	1-216-097-00	METAL GLAZE 100K 5% 1/10W
R281	1-216-049-00	METAL GLAZE 1K 5% 1/10W
R282	1-216-049-00	METAL GLAZE 1K 5% 1/10W
R291	1-216-298-00	METAL GLAZE 2.2 5% 1/10W
R293	1-216-025-00	METAL GLAZE 100 5% 1/10W
RV101	1-238-016-11	RES, ADJ, CARBON 10K (TRACKING GAIN)
RV102	1-238-016-11	RES, ADJ, CARBON 10K (FOCUS GAIN)
RV271	1-238-748-11	RES, VAR, CARBON 1K/1K (LEVEL)
S101	1-572-085-11	SWITCH, LEAF (LIMIT SW)
S191	1-572-086-11	SWITCH, LEAF (OUT SW)
S192	1-572-086-11	SWITCH, LEAF (IN SW)
S201	1-554-596-21	SWITCH, KEY BOARD (MUSIC SCAN)
S202	1-554-596-21	SWITCH, KEY BOARD (TIME)
S203	1-554-596-21	SWITCH, KEY BOARD (▲OPEN/CLOSE)
S204	1-554-596-21	SWITCH, KEY BOARD (■)
S205	1-554-596-21	SWITCH, KEY BOARD (▷/)
S206	1-554-596-21	SWITCH, KEY BOARD (◀◀)
S207	1-554-596-21	SWITCH, KEY BOARD (▷◁)
S208	1-554-596-21	SWITCH, KEY BOARD (PROGRAM)
S209	1-554-596-21	SWITCH, KEY BOARD (SHUFFLE)
S210	1-554-596-21	SWITCH, KEY BOARD (REPEAT)
S211	1-554-596-21	SWITCH, KEY BOARD (FADER)
S291	1-571-305-11	SWITCH, PUSH (1 KEY)(POWER)
S901	▲.1-571-722-11	(E,EA,AUS)...SWITCH, VOLTAGE SELECTION
T901	▲.1-449-824-11	(US,Canadian)...TRANSFORMER, POWER
T901	▲.1-449-825-11	(AEP)...TRANSFORMER, POWER
T901	▲.1-450-011-11	(E,EA,AUS)...TRANSFORMER, POWER
X201	1-567-775-11	VIBRATOR, CERAMIC (4.19MHz)
X251	1-567-908-11	VIBRATOR, CRYSTAL (16.9344MHz)

ACCESSORY & PACKING MATERIAL

1-465-282-11	(390)...REMOTE COMMANDER (RM-D90)
▲.1-555-074-11	(AUS).....CORD, POWER
▲.1-556-280-00	(E).....CORD, POWER
▲.1-558-834-11	(US,Canadian)...CORD, POWER
▲.1-558-835-11	(AEP,EA).....CORD, POWER
1-559-533-11	CORD, CONNECTION
▲.1-569-007-11	(E)...ADAPTOR, CONVERSION 2P
▲.1-569-008-11	(EA)...ADAPTOR, CONVERSION 2P
3-750-716-11	(Canadian,AEP,E,EA,AUS) ...MANUAL, INSTRUCTION
3-750-716-21	(US).....MANUAL, INSTRUCTION
3-750-716-41	(AEP).....MANUAL, INSTRUCTION
*3-795-629-11	(AEP)...INSTRUCTION
4-384-285-01	(390)...COVER, BATTERY
*4-925-388-61	(390)...INDIVIDUAL CARTON
*4-925-388-71	(190)...INDIVIDUAL CARTON
*4-925-389-01	CUSHION

Note:
The components identified by mark ▲ or dotted line with mark ▲ are critical for safety. Replace only with part number specified.

Note:
Les composants identifiés par une marque ▲ sont critiques pour la sécurité. Ne les remplacer que par une pièce portant le numéro spécifié.

CDP-190/390

SONY SERVICE MANUAL

US Model
AEP Model
E Model

CORRECTION-2

Australian Model

CDP-190/390

Correct your service manual as shown below.



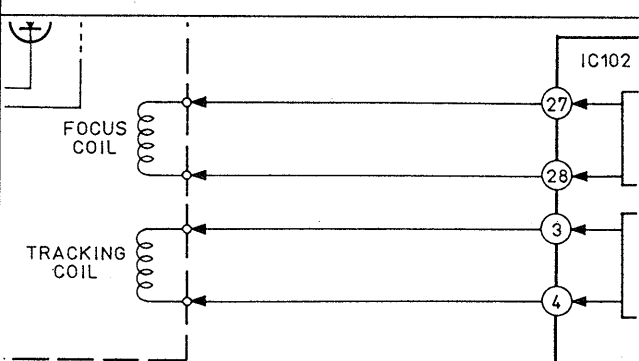
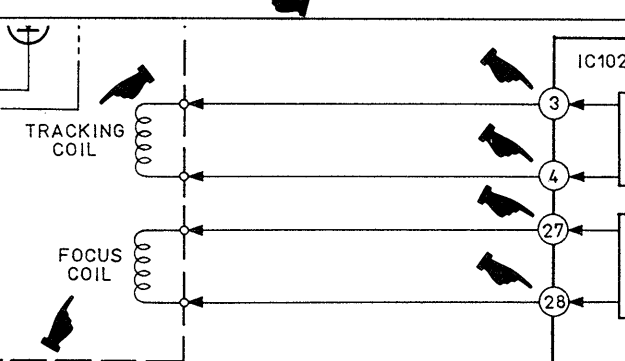
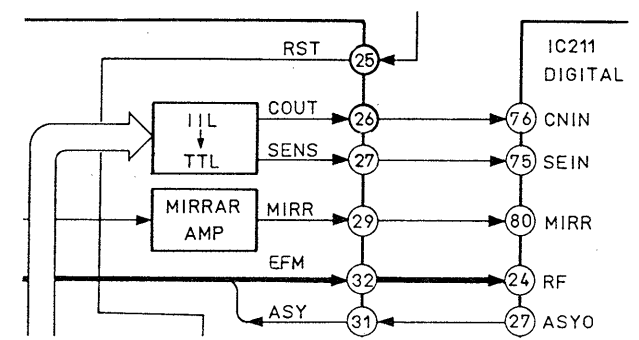
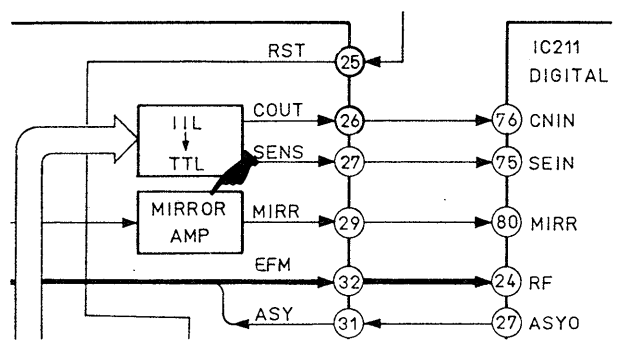
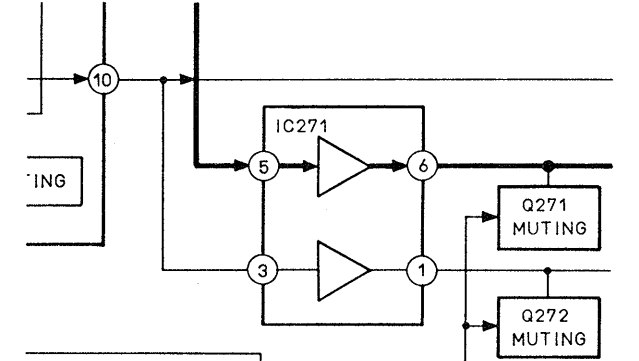
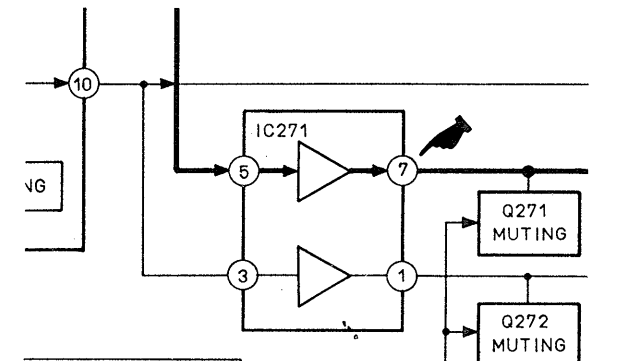

Canadian Model

CDP-190

: indicates corrected portion.

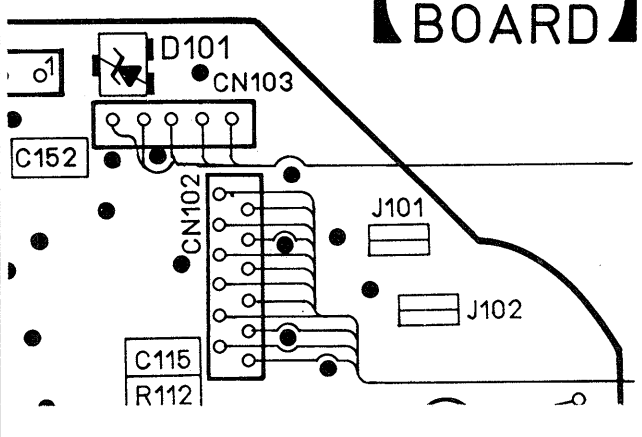
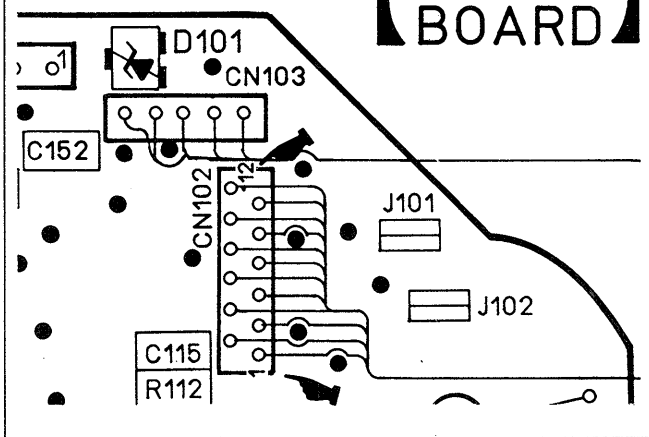
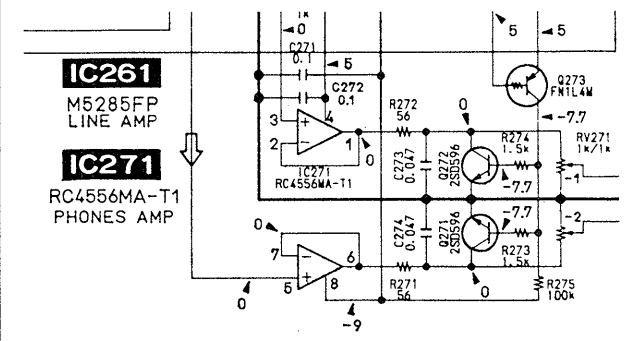
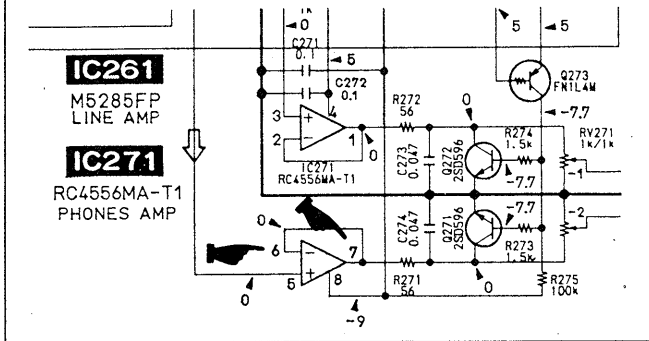
Page	INCORRECT	CORRECT
7	<p>E-F Blance Check</p> <p>Procedure :</p> <p>1. Connect test point TP (ADJ) and TP (TES) to ground with lead wire.</p>	<p>E-F Blance Check</p> <p>Procedure :</p> <p>1. Connect test point TP (ADJ) to ground and TP (TES) to TP (VC) with lead wire.</p>
9		
		
11		

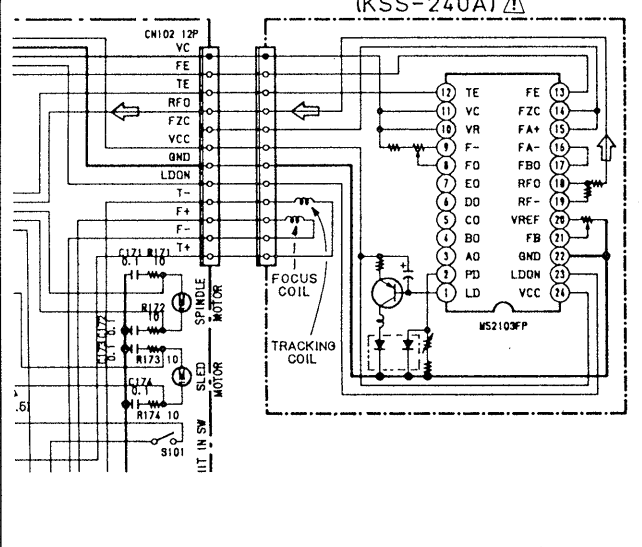
 : indicates corrected portion.

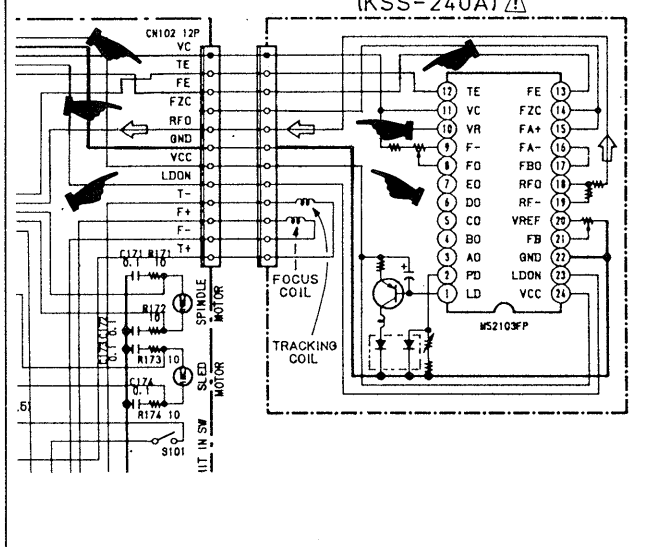
Page	INCORRECT	CORRECT																																								
14	<p style="text-align: center;">BD BOARD</p> 	<p style="text-align: center;">BD BOARD</p> 																																								
15	<p>IC261 M5285FP LINE AMP</p> <p>IC271 RC4556MA-T1 PHONES AMP</p> 	<p>IC261 M5285FP LINE AMP</p> <p>IC271 RC4556MA-T1 PHONES AMP</p> 																																								
17	<p style="text-align: center;">OPTICAL PICK-UP BLOCK (KSS-240A) </p> 	<p style="text-align: center;">OPTICAL PICK-UP BLOCK (KSS-240A) </p> 																																								
18	<table border="1" style="width: 100%; border-collapse: collapse;"> <tr> <td style="width: 5%;">26</td> <td style="width: 15%;">C. OUT</td> <td style="width: 5%;">O</td> <td style="width: 75%;">Tracking counter ou</td> </tr> <tr> <td>27</td> <td>SENS</td> <td>O</td> <td>Outputs internal sta</td> </tr> <tr> <td>28</td> <td>D GND</td> <td>O</td> <td>Digital ground, Grou</td> </tr> <tr> <td>29</td> <td>MIRR</td> <td>O</td> <td>Mirror output digita</td> </tr> <tr> <td>30</td> <td>DFCT</td> <td>O</td> <td>Deffect output, Deffe</td> </tr> </table>	26	C. OUT	O	Tracking counter ou	27	SENS	O	Outputs internal sta	28	D GND	O	Digital ground, Grou	29	MIRR	O	Mirror output digita	30	DFCT	O	Deffect output, Deffe	<table border="1" style="width: 100%; border-collapse: collapse;"> <tr> <td style="width: 5%;">26</td> <td style="width: 15%;">C. OUT</td> <td style="width: 5%;">O</td> <td style="width: 75%;">Tracking counter ou</td> </tr> <tr> <td>27</td> <td>SENS</td> <td>O</td> <td>Outputs internal sta</td> </tr> <tr> <td>28</td> <td>D GND</td> <td>O</td> <td>Digital ground, Grou</td> </tr> <tr> <td>29</td> <td>MIRR</td> <td>O</td> <td>Mirror output digita</td> </tr> <tr> <td>30</td> <td>DFCT</td> <td>O</td> <td>Deffect output, Deffe</td> </tr> </table>	26	C. OUT	O	Tracking counter ou	27	SENS	O	Outputs internal sta	28	D GND	O	Digital ground, Grou	29	MIRR	O	Mirror output digita	30	DFCT	O	Deffect output, Deffe
26	C. OUT	O	Tracking counter ou																																							
27	SENS	O	Outputs internal sta																																							
28	D GND	O	Digital ground, Grou																																							
29	MIRR	O	Mirror output digita																																							
30	DFCT	O	Deffect output, Deffe																																							
26	C. OUT	O	Tracking counter ou																																							
27	SENS	O	Outputs internal sta																																							
28	D GND	O	Digital ground, Grou																																							
29	MIRR	O	Mirror output digita																																							
30	DFCT	O	Deffect output, Deffe																																							