

**STEREO CASSETTE RECEIVER/
COMPACT DISC PLAYER**

MODEL MX-W50

INSTRUCTION MANUAL

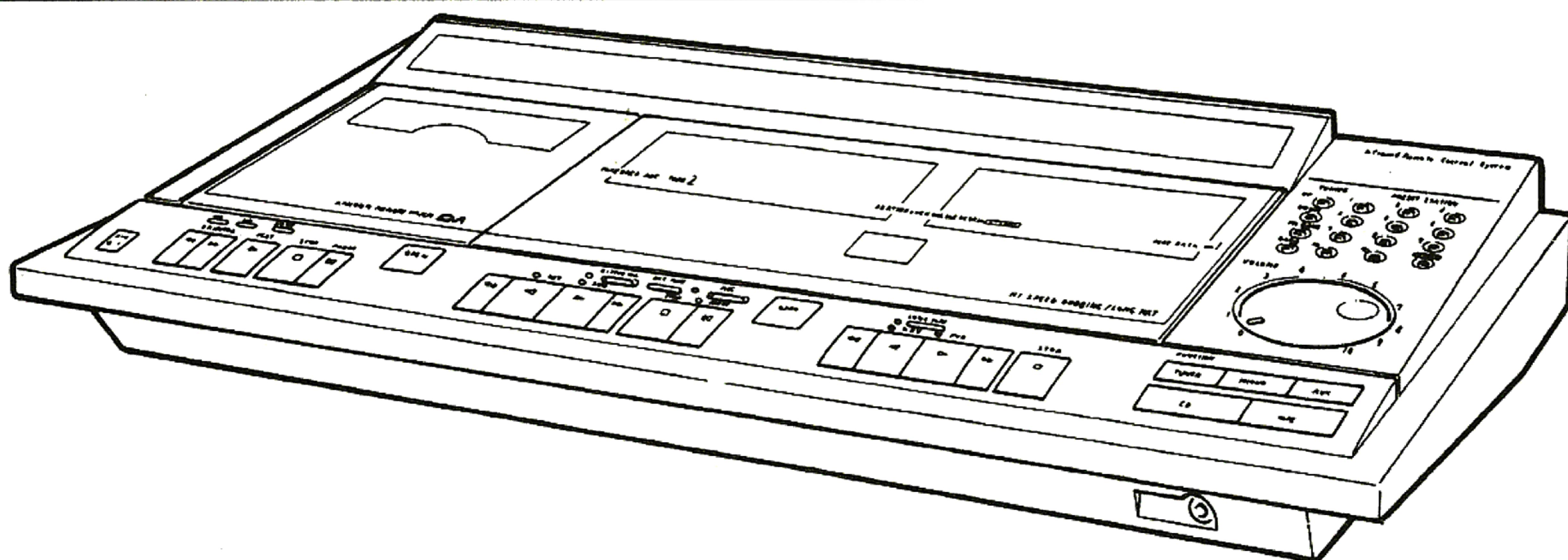

HITACHI CD Slimline System

For U.S.A.

WARNING: TO PREVENT FIRE OR ELECTRIC SHOCK, DO NOT EXPOSE THIS APPLIANCE TO RAIN OR MOISTURE.



CAUTION
RISK OF ELECTRIC SHOCK
DO NOT OPEN



CAUTION: TO REDUCE THE RISK OF ELECTRIC SHOCK, DO NOT REMOVE COVER. NO USER-SERVICEABLE PARTS INSIDE. REFER SERVICING TO QUALIFIED SERVICE PERSONNEL.



Explanation of Graphical Symbols

The lightning flash with arrowhead symbol, within an equilateral triangle, is intended to alert the user to the presence of uninsulated "dangerous voltage" within the product's enclosure that may be of sufficient magnitude to constitute a risk of electric shock to persons.



The exclamation point within an equilateral triangle is intended to alert the user to the presence of important operating and maintenance (servicing) instructions in the literature accompanying the appliance.

Notice: The Power button located on the front panel is secondarily connected and does not separate the apparatus from the mains supply in the switched-off position. If the unit is to be left unattended for a long period, it is recommended that the unit be completely switched off and the plug removed.

INFORMATION

This equipment generates and uses radio frequency energy and if not installed and used properly, that is, in strict accordance with the manufacturer's instructions, may cause interference to radio and television reception. It has been type tested and found to comply with the limits for a Class B computing device in accordance with the specifications in Subpart J of Part 15 of FCC Rules, which are designed to provide reasonable protection against such interference in a residential installation. However, there is no guarantee that interference will not occur in a particular installation. If this equipment does cause interference to radio or television reception, which can be determined by turning the equipment off and on, the user is encouraged to try to correct the interference by one or more of the following measures:

- Reorient the receiving antenna
- Relocate the equipment with respect to the receiver
- Move the equipment away from the receiver
- Plug the equipment into a different outlet so that equipment and receiver are on different branch circuits.

If necessary, the user should consult the dealer or an experienced radio/television technician for additional suggestions. The user may find the following booklet prepared by the Federal Communications Commission helpful: "How to Identify and Resolve Radio-TV Interference Problems". This booklet is available from the U.S. Government Printing Office, Washington, D.C., 20402, Stock No. 004-000-00345-4.

For U.K. and Australia

NOTICE: The operate button located on the front panel is secondarily connected and does not separate the apparatus from the mains supply on the switched-off position. As to the indication of the operate button, "I" shows ON and "⏻" electrical power stand-by. If the unit is to be left unattended for a long period, it is recommended that the unit be completely switched off and the plug removed.

IMPORTANT SAFEGUARDS

SAFETY POINTS YOU SHOULD KNOW ABOUT YOUR AUDIO EQUIPMENT.

(FOR U.S.A.)

CAUTION:

- Read all of these instructions.
- Save these instructions for later use.
- Follow all warnings and instructions marked on the audio equipment.

1. **Read Instructions** — All the safety and operating instructions should be read before the appliance is operated.
2. **Retain Instructions** — The safety and operating instructions should be retained for future reference.
3. **Heed Warnings** — All warnings on the appliance and in the operating instructions should be adhered to.
4. **Follow Instructions** — All operating and use instructions should be followed.
5. **Water and Moisture** — The appliance should not be used near water — for example, near a bathtub, washbowl, kitchen sink, laundry tub, in a wet basement, or near a swimming pool, etc.
6. **Carts and Stands** — The appliance should be used only with a cart or stand that is recommended by the manufacturer. An appliance and cart combination should be moved with care. Quick stops, excessive force, and uneven surfaces may cause the appliance and cart combination to overturn.



7. **Wall or Ceiling Mounting** — The appliance should be mounted to a wall or ceiling only as recommended by the manufacturer.
8. **Heat** — The appliance should be situated away from heat sources such as radiators, heat registers, stoves, or other appliances (including amplifiers) that produce heat.
9. **Ventilation** — The appliance should be situated so that its location or position does not interfere with its proper ventilation. For example, the appliance should not be situated on a bed, sofa, rug, or similar surface that may block the ventilation openings; or, placed in a built-in installation, such as a bookcase or cabinet that may impede the flow of air through the ventilation openings.
10. **Power Sources** — The appliance should be connected to a power supply only of the type described in the operating instructions or as marked on the appliance.
11. **Grounding or Polarization** — The precautions that should be taken so that the grounding or polarization means of an appliance is not defeated.
12. **Power-Cord Protection** — Power-supply cords should be routed so that they are not likely to be walked on or pinched by items placed upon or against them, paying particular attention to cords at plugs, convenience receptacles, and the point where they exit from the appliance.
13. **Cleaning** — The appliance should be cleaned only as recommended by the manufacturer.
14. **Power Lines** — An outdoor antenna should be located away from power lines.
15. **Outdoor Antenna Grounding** — If an outside antenna is connected to the receiver, be sure the antenna system is grounded so as to provide some protection against voltage surges and built up static charges. Section 810 of the National

Electrical Code, ANSI/NFPA No. 70—1984, provides information with respect to proper grounding of the mast and supporting structure, grounding of the lead-in wire to an antenna discharge unit, size of grounding conductors, location of antenna-discharge unit, connection to grounding electrodes, and requirements for the grounding electrode. See Figure below.

EXAMPLE OF ANTENNA GROUNDING ACCORDING TO NATIONAL ELECTRICAL CODE INSTRUCTIONS CONTAINED IN ARTICLE 810 — "RADIO AND TELEVISION EQUIPMENT"

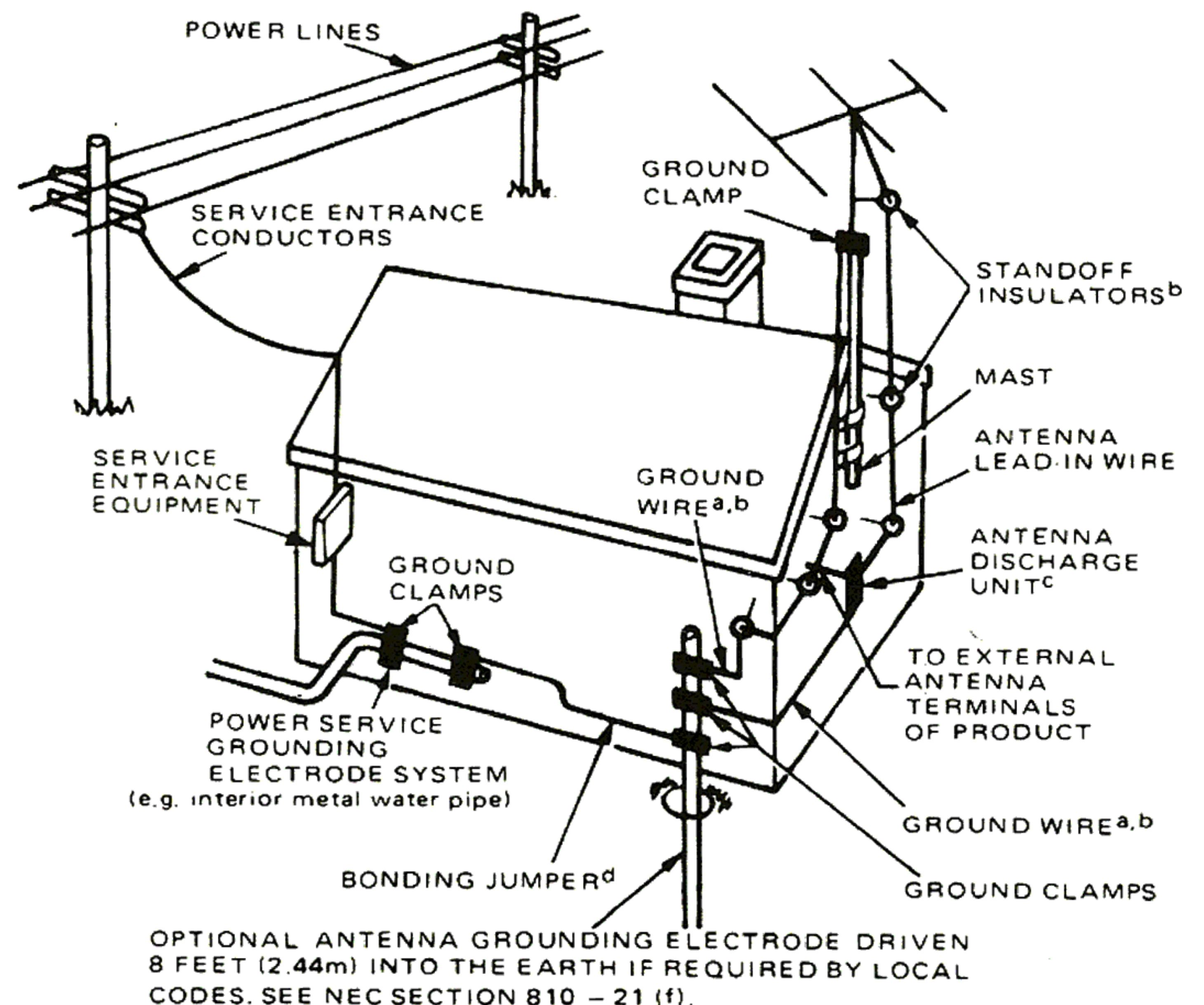

- a Use No. 10 AWG (5.3 mm²) copper, No. 8 AWG (8.4 mm²) aluminum, No. 17 AWG (1.0 mm²) copper-clad steel or bronze wire, or larger, as a ground wire.
 - b Secure antenna lead-in and ground wires to house with stand-off insulators spaced from 4 feet (1.22 m) to 6 feet (1.83 m) apart.
 - c Mount antenna discharge unit as close as possible to where lead-in enters house.
 - d Use jumper wire not smaller than No.6 AWG (13.3 mm²) copper, or the equivalent, when a separate antenna-grounding electrode is used. See NEC Section 810-21(j).
16. **Nonuse Periods** — The power cord of the appliance should be unplugged from the outlet when left unused for a long period of time.
 17. **Object and Liquid Entry** — Care should be taken so that objects do not fall and liquids are not spilled into the enclosure through openings.
 18. **Damage Requiring Service** — The appliance should be serviced by qualified service personnel when:
 - A. The power-supply cord or the plug has been damaged; or
 - B. Objects have fallen, or liquid has been spilled into the appliance; or
 - C. The appliance has been exposed to rain; or
 - D. The appliance does not appear to operate normally or exhibits a marked change in performance; or
 - E. The appliance has been dropped, or the enclosure damaged.
 19. **Servicing** — The user should not attempt to service the appliance beyond that described in the operating instructions. All other servicing should be referred to qualified service personnel.



Note to CATV system installer

This reminder is provided to call the CATV system installer's attention to Article 820-22 of the NEC that provides guidelines for proper grounding and, in particular, specifies that the cable ground shall be connected to the grounding system of the building, as close to the point of cable entry as practical.

IMPORTANT FOR U.K.:

The wires in this mains lead are coloured in accordance with the following code:

Blue: NEUTRAL
Brown: LIVE

As the colours of the wires in the mains lead of this apparatus may not correspond with the coloured markings identifying the terminals in your plug proceed as follows:

The wire which is coloured BLUE must be connected to the terminals which is marked with the letter N or coloured BLACK.

The wire which is coloured BROWN must be connected to the terminal which is marked with the letter L or coloured RED.

COVERING RANGE AND STEP FREQUENCY

The tuning frequency range and the frequency steps are indicated below.

Area of use	FM Section		AM Section			
			MW		LW (U.K. only)	
	Frequency range	Frequency step	Frequency range	Frequency step	Frequency range	Frequency step
U.S.A.	87.9–107.9 MHz	200 kHz	530–1,710 kHz	10 kHz	—	—
U.K. and Australia	87.50–108.00 MHz	50 kHz	522–1,611 kHz	9 kHz	153–281 kHz	1 kHz

CAUTIONS

1. Protection circuit

Set the Power/Operate button to on "I". The sound is heard within about 4 sec. If the sound is not heard, set the Power/Operate button to off "⏻", and check the speakers are properly connected and the speaker terminals or speaker leads have not been short-circuited. Eliminate the cause of the trouble and set the Power/Operate button to on "I" again, after waiting for about 15 sec. with the Operate button at off "⏻". If the set still does not work, contact the dealer from whom you purchase this unit or your nearest HITACHI service station.

When listening at a very high volume level, the protection circuit may operate, causing the sound to be cut off. In this case, the sound will be restored after about 4 seconds.

If this happens frequently, however, lower the volume setting slightly.

2. Even when measuring the power output or listening to program sources with an 8 ohm load impedance, do not drive the model MX-W50 at full power for a long period of time.

3. Amplifier heat loss

A large power output amplifier radiates heat. Although ventilation holes are provided in the upper part of the case and the bottom case to improve heat dissipation, placing this unit in direct sunlight may interfere with this ventilation and malfunctions may occur. If the internal temperature rises, the power IC may be damaged. Take care not to block the ventilation holes.

4. Protection against temperature rise

The heat generated by this unit is dissipated efficiently with the ventilation holes in the top of the casing and bottom panel and with the large-sized heat sinks. Nevertheless, if an abnormally high rise in the temperature has been detected, the amplifier will stop operating and the sound will no longer be heard. If this happens, set the Power/Operate button to off, allow the unit to cool down and then set the Power/Operate button to on. If the relay is tripped again even after the unit has cooled down and the Power/Operate button is set to on, a malfunction inside the amplifier may be to blame. Contact the dealer from whom you purchased this unit or your nearest HITACHI service station.

AUTO FUNCTION SELECT FEATURE

- This unit has an auto function select feature. When the operating section of the source to be listened to is operated as shown below, the input is switched automatically and you will hear the source.

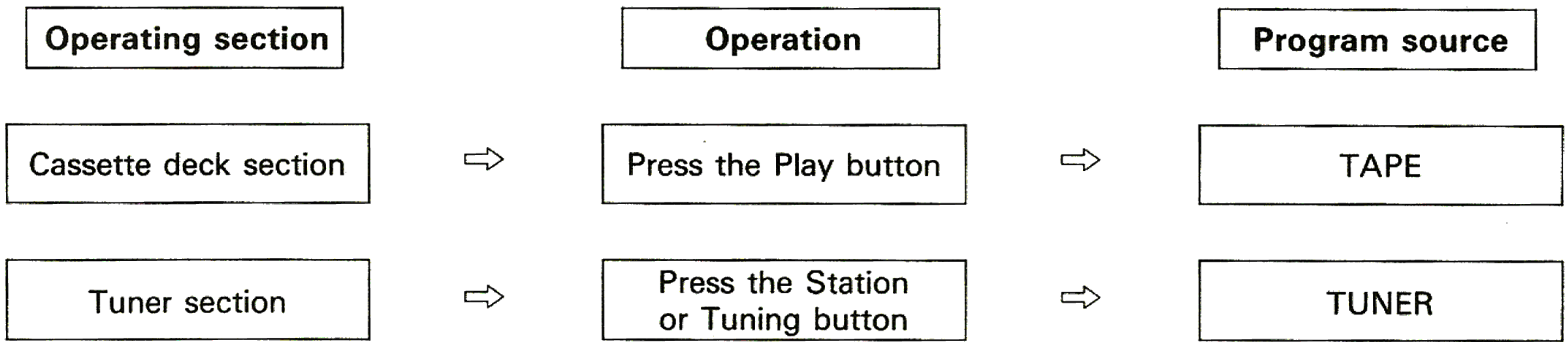

NAMES OF PARTS AND THEIR FUNCTIONS

- ① **Power/Operate button**
Press this button to turn on the unit; press it again to turn it off. When the power is off " ⏻ ", none of the units connected to it will function, however the control system of this unit remains energized.
- ② **Remote sensor window and indicator**
- ③ **Play indicator**
Flashes during access (high-speed movement) and lights during play.
- ④ **Pause indicator**
- ⑤ **Repeat indicator**
This indicator lights during normal repeat play, and "A-B" lights during repeat play between two designated points.
- ⑥ **Track display**
This displays the track number being played, or the track number selected with various search functions.
- ⑦ **Time display**
In the stop mode, this displays the total playing time of the disc loaded. During play, displays the elapsed time from the beginning of the track.
- ⑧ **Program indicator**
Lights during program play using the random memory function.
- ⑨ **Program indicator**
This lights together with the Program indicator ⑧ in the CD display. It shows that the random memory function of the CD player in this unit is being used.
- ⑩ **Music table indicator**
Shows the tracks (up to 20) selected using the CD random memory function using the Remote controller (RB-W50). The 21st tracks and later are shown only by the Track display ⑥.
- ⑪ **FM AUTO indicator**
When the FM mode select button ⑳ is set to AUTO in FM band, this indicator lights up.
- ⑫ **LOCKED indicator**
This lights up to indicate when a broadcast has been tuned in exactly and also it has a usable signal strength.
- ⑬ **FM STEREO indicator**
This lights up when an FM stereo broadcast has been received. It does not light up, however, when the FM mode is MONO or when the broadcasting station is transmitting a mono signal.
- ⑭ **Band indicator**
- ⑮ **Channel/Frequency display**
- ⑯ **Memory indicator**
This lights 5 seconds after the Memory button ㉓ is pressed to indicate that the microcomputer is in a memory enable state.
- ⑰ **Level meters**
- ⑱ **Function indicator**
Shows the input source selected by operating the Function select buttons ㉕ on this unit or the Function select buttons ㉞ on the Remote controller.
- ⑲ **Tuning buttons (UP/DOWN)**
Press UP or DOWN button to change the frequency.
- ⑳ **FM mode select button**
Every time this button is pressed, the mode is switched alternately between AUTO and MONO. The FM AUTO indicator ⑪ lights up in the "AUTO" FM mode.
AUTO: FM automatic tuning, automatic FM muting and automatic FM stereo.
MONO: FM manual tuning, FM muting OFF, FM mono reception.
- ㉑ **Band select button**
Press this button to select the received band. The selected band is displayed in the Band indicator ⑭.



- ②② **Station buttons (1 – 10) and 10+ button**
 These buttons are used in combination.
 (a) For CH1 – 10, press station buttons 1 – 10
 (b) For CH11 – 20, press the 10+ button, and within 5 seconds, press the desired station button 1 – 10.
 (c) In either case (a) or (b), the CH number is displayed first. When you wish to change to the frequency display, perform operation (a) or (b) again. Each time operation (a) or (b) is performed in this way, the CH number and frequency will be displayed alternately.

(Example 1): To select CH 2

- 1) Press station key "2".
- 2) The display will show "P02".
- 3) When key "2" is pressed again, the display will switch to frequency.
- 4) By repeating steps 1) and 3), the CH and frequency will be displayed alternately.



(Example 2): To select CH 12

- 1) Press the 10+ button.
- 2) The display will show the following: P1- The "-" (hyphen) will flash for about 5 seconds.
- 3) While the "-" (hyphen) is flashing, press station key "2".
- 4) The display will show "P12".
- 5) If you wish to change to the frequency display, repeat steps 1) and 3).
 In other words, whenever you wish to select CH 11 – 20, you must press the 10+ button.

- ②③ **Memory button**
 Press this button to engage the memory function.
- ②④ **Volume control and indicator**
 Use this control to adjust the sound volume. When the Volume control button " " or " " ⑦③ on the remote controller is pressed, the control turns while the indicator flashes and the sound volume can be adjusted. When the Muting button ⑦④ on the remote controller is pressed, the indicator flashes to show that the sound is muted.
- ②⑤ **Function select buttons**
 These are used to select the program source.
 PHONO For listening to a disc on the turntable connected to the Phono input jacks ⑥③. (The Function indicator "PHONO" ⑱ lights.)
 TUNER..... For listening to a broadcast. (The Function indicator "TUNER" ⑱ lights.)
 CD For listening to a compact disc. (The Function indicator " [] " ⑱ lights.)
 AUX For listening to a program source on a component connected to the AUX input jacks ⑥④. (The Function indicator " AUX " ⑱ lights.)
 TAPE For listening to a tape. (The Function indicator " TAPE " ⑱ lights.)

CD operate section

- ②⑥ **Fast back search button (◀◀)**
 Press to move in reverse at high speed.

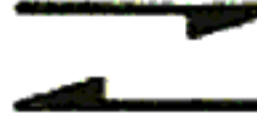
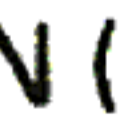
- ②⑦ **Fast forward search button (▶▶)**
 Press to move forward at high speed.
- ②⑧ **Repeat button**
 This button is pressed when performing repeat play.
- ②⑨ **Reverse skip/Track number button (◀◀)**
 Press to select a desired track number on the disc. Each time the button is pressed, the track number shown by the Track display ⑥ moves back one track number. When pressed continuously, the tracks are skipped continuously in the reversed direction.
- ③① **Forward skip/Track number button (▶▶)**
 Press to select a desired track number on the disc. Each time the button is pressed, the track number shown by the Track display ⑥ moves forward; when pressed continuously, tracks are skipped continuously in the forward direction.
- ③② **Play button (▶)**
 Press to begin play; the Play indicator ③ will light.
- ③③ **Stop button**
 Press this button to stop play or to clear the program.
- ③④ **Pause button (⏸)**
 Press during play to temporarily stop play; the Pause indicator ④ will light. Press this button to resume play at the point where it was paused.
- ③⑤ **Disc cover open button**
- ③⑥ **Tape counter/Reset button (TAPE-2)**
- ③⑦ **Graphic equalizer controls**
 These controls are used to adjust the sound character. Move the controls to boost/attenuate the levels of the desired frequency ranges.
- ③⑧ **Balance control**
 This adjusts the balance of right and left channel levels.
- ③⑨ **Reverse mode switch**
 During play (TAPE-1, TAPE-2)
 : Endless mode
 Both sides of the tape are played 16 times.
 : One-way mode
 Only one side of the tape is played.
 During recording (TAPE-2)
 : Both-way mode
 Both sides of the tape are recorded and then the tape stops.
 : One-way mode
 One side of the tape is recorded and then the tape stops.
- ③⑩ **Dolby NR switch**
 Set to ON () position when recording utilizing the Dolby NR system or playing back cassette tapes recorded through a Dolby NR system. **Turn off this switch during dubbing.**

Noise reduction manufactured under license from Dolby Laboratories Licensing Corporation. "Dolby" and the double-D symbol are trademarks of Dolby Laboratories Licensing Corporation.

Tape operate section

- ④① **High-Speed dubbing button/indicator**
Press this button with tapes loaded in TAPE-1 and TAPE-2 to start high-speed dubbing.
- ④② **Recording mute button**
- ④③ **Long play button/indicator**
Press this button for long play. The indicator lights during long play. See page 9 for details.

TAPE-2

- ④④ **Rewind button**
- ④⑤ **Reverse play button/indicator**
- ④⑥ **Forward play button/indicator**
- ④⑦ **Fast forward button**
- ④⑧ **Stop button**
- ④⑨ **Pause button/indicator**
- ④⑩ **Record button/indicator**
- ⑤① **Cassette cover open button**

TAPE-1



- ⑤② **Rewind button**
- ⑤③ **Reverse play button/indicator**
- ⑤④ **Forward play button/indicator**
- ⑤⑤ **Fast forward button**
- ⑤⑥ **Stop button**
- ⑤⑦ **Headphones jack**
When headphones are plugged into this jack, the sound from the speakers are cut off. (A switching sound is heard at this time as the circuit switches but this is not a fault.)

Rear

- ⑥⑦ **FM DIN (75 ohms) antenna jack (for U.K. and Australia)**
- ⑥⑧ **Ground terminal (GND)**
- ⑥⑨ **FM antenna terminal (75 ohm)**
- ⑥⑩ **AM external antenna terminal (AM EXT.)**
- ⑥⑪ **AM loop antenna terminal**
- ⑥⑫ **Ground terminal (GND)**
- ⑥⑬ **PHONO input jacks**

- ⑥⑭ **AUX input jacks**
- ⑥⑮ **Line out jacks**
- ⑥⑯ **Speaker terminals**
- ⑥⑰ **Power supply cord**

Wireless remote controller (RB-W50)

- ⑥⑱ **Remote control operate button**
- ⑥⑲ **Function select buttons**
When "TAPE-1" or "TAPE-2" is pressed with a tape loaded in TAPE-1 or TAPE-2, playback will start automatically.
- ⑦⑰ **Program button**
Use this button to set the CD player to the programming mode.
- ⑦⑱ **Numeric buttons**
Use these to select tracks of a CD or select a preset station of the tuner.
- ⑦⑲ **Clear button**
Press this button to omit or clear the program in the CD player.
- ⑦⑳ **Volume control buttons**
By pressing the "" button, the volume level will be reduced, and by pressing the "" button, the volume level will be raised.
- ⑦㉑ **Muting button**
Press this button to mute the sound from the speakers. Pressing it again will restore the original sound volume.
- ⑦㉒ **Stop button (for CD, TAPE-1, TAPE-2)**
Stops the source ("CD", "TAPE-1" or "TAPE-2") selected with the Function select button ⑥⑲.
- ⑦㉓ **Forward play button (for CD, TAPE-1, TAPE-2)**
- ⑦㉔ **Reverse play button (for TAPE-1, TAPE-2)**
- ⑦㉕ **Pause button (for CD, TAPE-1, TAPE-2)**
- ⑦㉖ **Fast forward/search button (for CD, TAPE-1, TAPE-2)**
- ⑦㉗ **Fast back/search button (for CD, TAPE-1, TAPE-2)**
- ⑦㉘ **Forward skip/Track number button (for CD)**
- ⑦㉙ **Reverse skip/Track number button (for CD)**
- ⑦㉚ **Record buttons (TAPE-2)**
Press these buttons simultaneously to record the tape loaded in the cassette deck (TAPE-2).

CONNECTIONS

See page 14 for the connection diagram.

Connections between equipment

Be sure to set the Volume control ②④ to "0" position and turn off the Power/Operate button. Insert or pull out connection leads holding the plug.

Connection of Loudspeakers

This unit is provided with terminals for loudspeakers.

When connecting the speaker cords, push the red and black buttons on the speaker terminals and connect them without confusing (+), (−) and L, R.

NOTE:

Be sure to remove the speaker cords by pushing the red and black buttons, otherwise the terminals may be damaged.

Antenna

• When receiving an FM broadcast

Signal strength differs from place to place. Select the position where broadcasts can be received most clearly, changing the height and direction of the lead antenna while listening to a broadcast.

When signal is strong: Such as near the broadcasting station, reception of broadcasts may be distorted. In such a case, do not use the external antenna.

When signal strength is relatively weak: Use the FM lead antenna.

When signal strength is weak: Use an exclusive FM antenna.

• When Receiving an MW/LW Broadcast

Connect an AM loop antenna to the AM loop antenna terminals on the rear of the unit.

When listening to MW/LW broadcasts, loop antenna works. If the reception is not satisfactory, connect an external AM antenna.

Note: Leave the AM loop antenna connected when connecting an external AM antenna.

• Using the AM loop antenna

CAUTION:

Do not bring the speaker cords or power cord as well as other connecting cords near the AM loop antenna.

OPERATION

RADIO

■ FM reception

1. Set the Power/Operate button ① to on "I".
2. Press the Function select button ②⑤ or ⑥⑨ "TUNER".
3. Set the Band select button ②① so that FM is displayed in the Band indicator ①④.
4. Tune in the FM station using one of the following methods:
 - (a) Set to the FM auto mode using the FM mode select button ②⑩. When the Tuning button (UP or DOWN side) ①⑨ is pressed, auto scanning will start. When a broadcast is received, the Locked indicator ①② will light and scanning will stop automatically.
 - (b) Set to the FM mono mode using the FM mode select button ②⑩. Holding the Tuning button (UP or DOWN side) ①⑨ changes the frequency received continuously. Release the button near the required frequency to stop scanning, then press the button momentarily several times to tune to the required stations. Set to the FM mono mode when the received signal is weak and it is hard to listen to the broadcast in the FM auto mode; the broadcast will be easier to hear.
 - (c) Press the Preset station button and 10+ button ②② or Numeric button ⑦① to select a station which has been previously programmed into the memory with this button.

■ AM (MW, LW) reception

1. Set the Power/Operate button ① to on "I".
2. Press the Function select button ②⑤ or ⑥⑨ "TUNER".
3. Set the Band select button ②① so that AM (MW, LW) is displayed in the Band indicator ①④.
4. Tune in the AM (MW, LW) station using one of the following methods:
 - (a) Tuning button (UP or DOWN side) ①⑨ functions in the manual tuning mode with AM reception. Hold down the Tuning button (UP or DOWN side) to change the frequency received continuously. Release the button near the required station to stop scanning, then press the button momentarily several times to tune to the required station. The tuning point is indicated by the Locked indicator ①②.

- (b) Press the Preset station buttons and 10+ button ②② or Numeric button ⑦①.

■ How to program the stations into the preset buttons

1. Tune in the station to be memorized using the Tuning button ①⑨ (UP or DOWN).
2. The Memory indicator ①⑥ lights up for about 4 seconds when the Memory button ②③ is pressed. While the Memory indicator ①⑥ is lighted, press the Preset station button and 10+ button ②② to the preset channel 1 – 20 which is to be memorized. The Memory indicator goes off simultaneously to indicate that the broadcasting station has been memorized.

Note:

the station programming function in this unit allows up to 20 AM (MW/LW) and FM stations to be preset at random.

■ Last channel memory function [FM or AM (MW, LW)]

The microcomputer used in this unit has a last channel memory for both FM and AM (MW, LW). When the AM (MW, LW)/FM function is selected after another function has been selected, this memory allows the broadcasting station last received before the selection to be heard.

Even if the Power/Operate button ① is set to off "⏻", the last channel memory will be retained since the microcomputer is provided with a memory back-up, and when the Power/Operate button ① is set to on "I" again, the last channel memory will be recalled.

Note:

Even when the power cord is disconnected, the preset stations are retained by a capacitor back-up system for a few days.

However, if power is not supplied to the unit for a long time, the stations are sometimes erased. At that time, preset the stations again.

COMPACT DISC

1. Set the Power/Operate button ① to on "I".
2. Press the Function select button ②⑤ or ⑥⑨ "CD".

3. Press the Disc cover open button (34) to open the disc cover.
4. Holding the disc so that your fingers do not touch its surface, place it in the center of the disc turntable with the label side face upward.
5. Push the disc cover closed by hand. The Track display (6) shows the total number of tracks on the disc.
6. Press the Play button (31) or (76) to start play.
7. Press the Pause button (33) or (78) when a temporary halt is desired when playing a compact disc. To resume play, press this button again.
8. Press the Stop button (32) or (75) to stop play. The program is cleared at the same time.
 - When the disc comes to the end of its play, it will automatically stop.

- If the total number of tracks is not displayed after disc cover closing, check to make sure you have not placed the disc upside down.
- If playback does not begin even after pressing the Play button (31) or (76), try pressing the Stop button (32) or (75) once, then operate again for playback.

■ OTHER USES OF CD PLAYER

—Direct search system

- **To begin disc playback from a desired track:**
Set a disc and press the Forward or Reverse skip/Track number button (30), (81) or (29), (82) to display the number of the track to be played in the Track display (6). Press the Play button (31) or (76); play will start from the specified track.

—Manual search

By pressing the Fast forward (27), (79) or Fast back search button (26), (80) you can listen quickly to chosen selections. It is very convenient for searching for a chosen portion of a long program and beginning playback from that portion.

—Skip search system

- **To move to a desired track during playback:**
Press the Forward or Reverse skip/Track number button (30), (81) or (29), (82) during play so that the number of the track to be listened to is shown by the Track display (6). Play will be switched to the specified track.

(Example)

- **To listen to the track following that presently being played:**
Press the Forward skip/Track number button (30), (81) once.
- **To listen to the presently playing track once again:**
Press the Reverse skip/Track number button (29), (82) once.
- **To listen to the track previous to the one presently playing:**
Press the Reverse skip/Track number button (29), (82) two times in succession.

NOTE:

When skip search is used using a disc with index numbers, the previous track may be played. In this case, select the required track using the Numeric buttons (71) on the remote control unit.

—Program play with random memory search system

The random memory track search function can be performed only from the Remote controller (RB-W50). This function searches up to 32 required tracks on the disc in any desired order and plays them automatically.

1. Set a disc and press the Program button (70) in the stop mode. The Program indicators (8) and (9) light in the display.
2. Press the Numeric buttons (71) to select the tracks to be programmed.
3. Press the Play button (31) or (76). Play will be started in an order of the programmed tracks.

NOTE:

If more than 32 tracks are programmed, the 32rd track and more will not be memorized.

EXAMPLE:

Using a disc with 30 tracks, program the tracks in the order, 3rd — 26th — 11th.

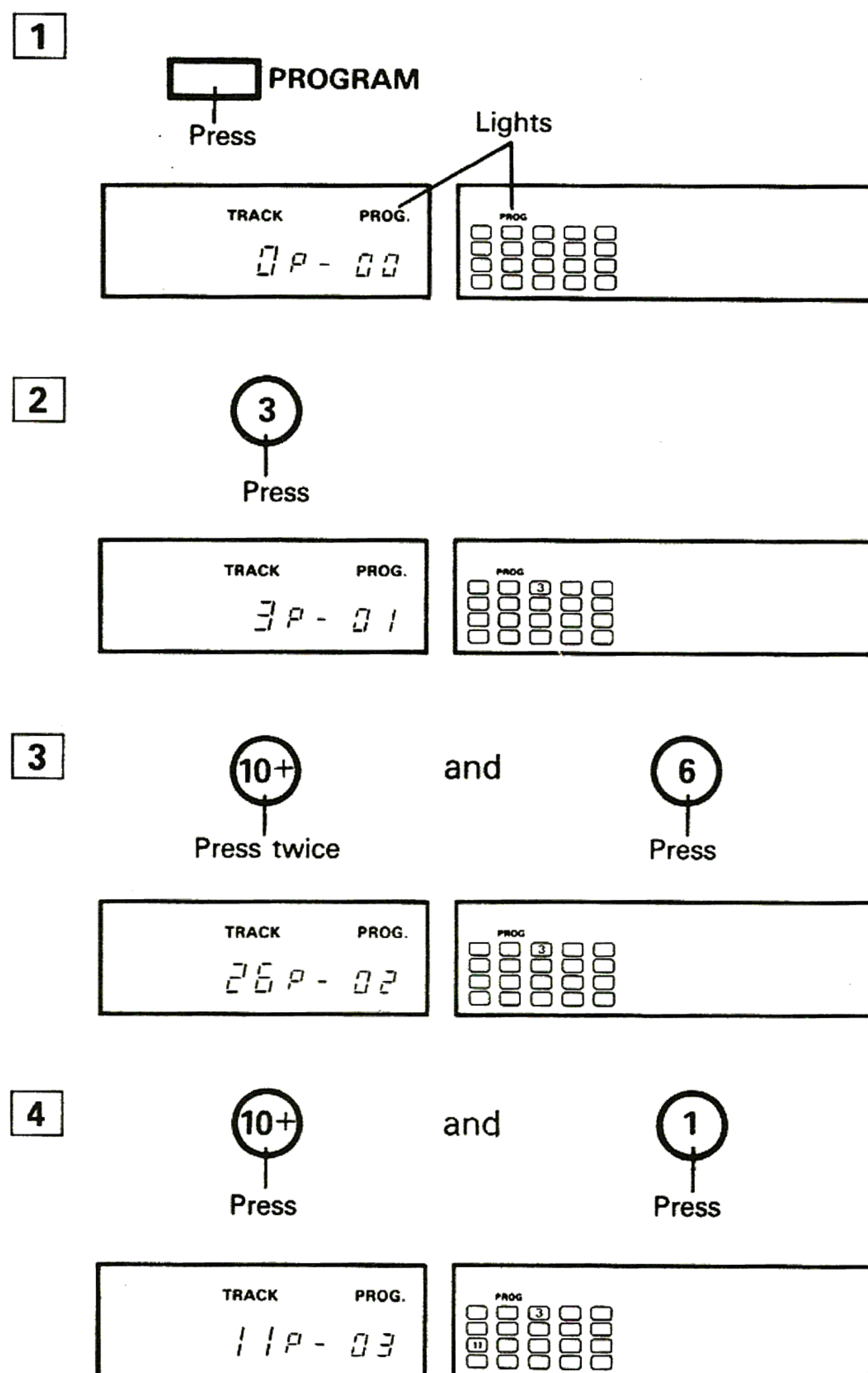

Programming has now been completed. Press the Forward play button (76). Play will start.

- If you make a mistake in programming the order of tracks, press the Clear button (72) to clear the programmed tracks. Every time the Clear button (72) is pressed, each track is cleared in the reverse order to programming.
- To clear all the programmed tracks, press the Stop button (75).

Notes:

- After the programmed tracks are played, they are cleared. If you want to listen to the programmed tracks repeatedly, press the Repeat button (28) on the main unit before starting playback.
- All the programmed tracks are cleared when the Operate button is set to off "⏻" or the Function select button other than "CD" is pressed.

—Repeat play—

Repeat play can be performed of all the tracks on the disc, or only those tracks programmed. In addition, you can perform repeat play between any two designated points on the disc.

■ When you want to repeat all tracks or only the programmed tracks

Set a disc and press the Repeat button (28). Press the Play button (31). Play will be started and all tracks will be played repeatedly until the Stop button (32) or (75) is pressed.

- If the Repeat button (28) is pressed when playing a disc, repeat play can be done.
- If repeat play is engaged after programming the tracks (see "Program play with random memory search system"), only the programmed tracks will be played repeatedly.

■ Repeat play between two (A and B) points

During playback, press the Repeat button (28) at the point (A) at which you wish repeat play to begin; press the Repeat button (28) again at the point (B) at which you wish repeat play to end. The playback will return to the first point at which you pressed and Repeat button (28), and repeat play will begin there.

To cancel the repeat play, press the Repeat button (28) several times till the Repeat indicator (5) goes out, and the unit will be switched to the normal playback mode.

—Pause-standby—

By using the three following methods, you can search for tracks or parts of tracks and place the unit in the pause (standby) mode. When the Pause button (33) or (78) is pressed, playback will begin.

■ Searching for the first track on the disc

After placing the disc in the player, merely press the Pause button (33) or (78). The unit will search for the first track of the disc and enter the pause mode.

■ Searching by random memory search system

1. Perform random memory programming.
2. Press the Pause button (33) or (78). The unit will search for the first track entered in its memory and enter the pause mode.

■ Searching by Direct Search System

1. Press the Pause button (33) or (78).
2. Select the track number you wish to listen to using the Forward (30), (81) or the Reverse skip/Track number button (29), (82).
The unit will search for the selected track and enter the pause mode.

TAPE DECK

■ CASSETTE INSERTION AND REMOVAL

See figures 10, 11, 12 on page 18.

• Insertion

1. Insert the cassette under the tab in the back of the cassette holder with the exposed tape toward the front. (Fig. 10)
2. Push down the front of the cassette. A click is heard and the cassette locks. (Fig. 11)

When inserting a cassette, always check that a click is heard and the cassette locks firmly. If the cassette does not lock, it may cause a malfunction.

• Removal

1. Hold the cassette by the both sides of the edge where the tape is exposed and lift it up. (Fig. 12)

Never take out the cassette during the operation to protect the mechanism.

■ BEFORE USING

- This unit is equipped with the AUTO REVERSE function so that the direction of the tape can be changed without removing the cassette tape. For practical purposes, these instructions will identify playback as (▷), fast forward as (▷▷) and rewind as (◁◁). When the tape is travelling in reverse direction (◁) will mean reverse playback, (◁◁) as fast forward and (▷▷) as rewind.
- Tape selection is not required because the auto tape selector is employed.

—Playback (TAPE-1, TAPE-2)—

1. Set the Power/Operate button (1) to on "I".
2. Set the cassette tape in the cassette holder.
3. Set the Dolby NR switch (39) according to the tape.
4. Set the Reverse mode switch to the required position.
5. Press the Forward (45) or (53) or Reverse play button (44) or (52) to start playback.
(If the Function select button (69) "TAPE-1" or "TAPE-2" on Remote controller RB-W50 is pressed, play will be started automatically. Press the Forward or Reverse play button (76) or (77) to select the tape play direction.)
6. When a temporary halt is desired during playback in TAPE-2, press the Pause button (48) or (78).
Press the Pause button (48) or (78) to start playback again.
7. To stop playback, depress the Stop button (47) or (55).

—Full auto stop mechanism—

When the tape comes to its end during recording and playback with the Reverse mode switch (38) set to the one way mode, and during fast forward and rewind, the tape stops automatically.

—Recording (TAPE-2)—

1. Set the Power/Operate switch (1) to on "I" and insert the cassette tape to be recorded into the TAPE-2 cassette holder.
2. Use the Function select buttons (25) or (69) to select the source to be recorded and prepare the source for play following its procedure.
3. Set the Dolby NR switch (39) and Reverse mode switch (38) to required position.
4. Pressing the Record button (49) or (83) first, then pressing the Pause button (48) or (78) places the deck in the recording standby mode.
5. Play the source to be recorded and simultaneously press the Pause button (48) or (78) to start recording.
6. To stop recording, press the Stop button (47) or (75).

■ Recording mute button

This can cut advertising and narrations when recording broadcasts and leave non-recorded sections between tunes (approx. 4 seconds) easily.

1. Press the Recording mute button (41) when a cut is required during recording. A non-recorded section of approx. 4 seconds is left and the unit enters the recording standby mode.
2. Press the Pause button (48) or (78) to restart recording.

■ Erasing

When a recording is being made, any sound already on the tracks is automatically erased before the new recording is made. Erasure is accomplished only when the deck is in the recording mode.

If you wish to erase a tape without making a new recording, press the Function select button "TAPE" and perform recording without playing TAPE-1. For erasing with less noise, remove input cords, etc.

Note: The erase operation is not possible while playing TAPE-1 because the deck enters the dubbing mode.

—Dubbing (tape-to-tape recording) (TAPE-1 ⇒ TAPE-2)—

1. Set the Power/Operate button (1) to on "I".
2. Insert the tape to be played back into TAPE-1, and the tape to be recorded on, into TAPE-2.
Note: When dubbing, the tape used in TAPE-2 should be of a higher quality than the one used in TAPE-1.
3. Press the Function select button (25) "TAPE".
4. Set the Dolby NR switch (39) to "OFF" position.
5. **To start Normal speed dubbing**, press the Forward (53) or Reverse play button (52) of TAPE-1 and simultaneously press the Record button (49) of TAPE-2. **To start Hi-speed dubbing**, press the Hi-speed dubbing button (40).
6. Simultaneously press the Stop button (47) of TAPE-2 and Stop button (55) of TAPE-1 to stop dubbing.

Note: To perform high-speed dubbing, set both TAPE-1 and TAPE-2 to the stop modes and then press the High-speed dubbing button (40).

This equipment should not be used for taking copies of tapes in breach of copyright. Copyright subsists in most pre-recorded tapes.

—Dolby NR (Noise Reduction) System—

The Dolby NR system reduces hissing noise. When the tape recorded with the Dolby NR switch (39) turned ON (⏻) is played back with the switch ON, you can enjoy sound with less hiss noise.

LONG PLAY (CD ▷ TAPE-1 ▷ TAPE-2)

1. Press the Function select button (25) "CD". (If, when the Function select button (25) is set to "TAPE", long play is engaged, long play is performed using only TAPE-1 and TAPE-2.)
2. Set a disc in the CD player and tapes in TAPE-1 and TAPE-2. (It is not necessary to load all these sources. Play is performed in the order, CD ▷ TAPE-1 ▷ TAPE-2, omitting the source that is not loaded.)
3. Set the Reverse mode switch (38) to the required position.
4. Press the Long play button (42). Long play will start.

—Releasing long play—

- Press the Long play button (42) again.
- Press the Stop button (32) of the CD player.

Note:

- Long play cannot be done during recording, and no recording can be done during long play.
- Start long play after setting TAPE-1 and TAPE-2 to the stop mode.
- Avoid replacing the CD during long play. If the disc cover is opened, long play will be released.
- When the Long play button (42) is pressed, the tape is rewound automatically and playback will start from the start.

The order of play is changed as follows according to the tape running mode set with the Reverse mode switch (38).

(One-way mode):

1. The CD is played to the end.
2. Only one sides of the tapes in TAPE-1 and TAPE-2 are played.
3. The CD is played repeatedly.

NOTE:

The CD player continues to play until long play is released.

(Endless mode):

1. The CD is played to the end.
2. Both sides of the tapes in TAPE-1 and TAPE-2 are played.
3. Steps "1" and "2" are performed repeatedly.

NOTE:

When the Stop button of the deck which is in the stop mode is pressed, the tape in this deck will not be played.

WIRELESS REMOTE CONTROL

When using the Remote controller, make sure that the Disc cover is closing.

Usable Range

Point the Remote controller towards the remote sensor window on the unit. The unit may not receive signals from the remote controller if it is at too great an angle as shown.

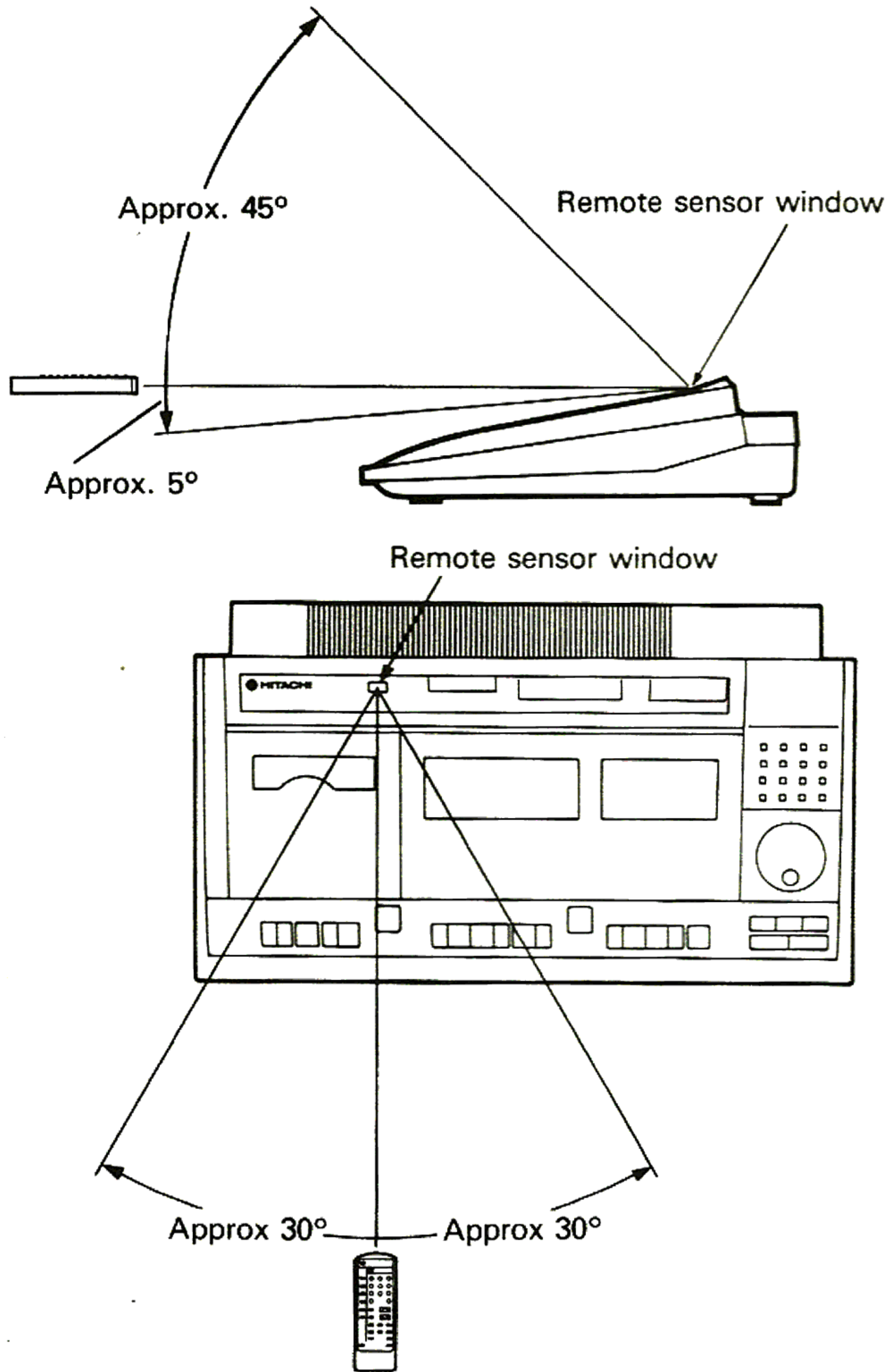

■ Loading batteries

See Fig. 9 on page 18.

Insert 2 "AA" cell (IEC R6) batteries.

1. To remove the battery compartment lid, press down on it while sliding as shown.
2. Insert batteries with their \oplus \ominus polarities correctly matched to the indicated diagram.
3. Replace the battery compartment lid, sliding it on unit it locks into place with a "click".

■ If the batteries are used incorrectly, there is a danger of the internal fluid leaking or the batteries bursting.

- Do not use new and old batteries together.
- Do not use different kinds of batteries together.
- Batteries consist of rechargeable and non-rechargeable types. Verify the type of battery by reading the caution label.
- If you are not going to use the remote control unit for a long period, remove the batteries.
- Do not heat, disassemble, or short circuit dry batteries, or throw them into a fire.

GRAPHIC EQUALIZER CONTROLS

As this unit is equipped with a graphic equalizer, fine adjustment of the sound is possible. When the Graphic equalizer controls (36) are moved, both right and left channel frequencies are adjusted at the same time.

EQUALIZER CONTROLS

- **80 Hz**
Makes low-range sounds even deeper. When the control is raised, the beat of a bass drum is more intense, while lowering it removes "muddiness" from the lower range.
- **300 Hz**
Affects intensity. When the control is raised, bass rhythms begin to sound more articulated.
- **1 kHz**
Gives depth to music. Raising the control projects the sound. Lowering the control retracts it.
- **3.5 kHz**
Affects brass, strings and vocals. When raised they sound sharper and brighter, and when lowered they sound milder.
- **12 kHz**
Affects the whole atmosphere of the music. Raising the control makes strings sound more sensitive, more exquisite.

MAINTENANCE AND RECORD PREVENT DEVICE

See figures 13, 14 on page 18.

■ Cleaning of cassette sections (TAPE-1/TAPE-2) Fig. 13

- Clean the heads, capstan and pressure roller periodically with a cleaning stick moistened with alcohol or methylated spirits.
- Never use sharp or metallic instruments or tools for cleaning these parts.
- The easiest cleaning method is by using a Hitachi head cleaning cassette tape.

■ Recording protection Fig. 14

If the plastic tabs of the cassette are punched out (by a screwdriver or similar tool), the recordings can be protected against accidental erasure.

■ Cleaning CD player

- Clean the pickup lens with a cleaning stick or blower.
Note: Do not rub the pickup lens strongly, as this may damage the lens and may cause trouble.

■ Treat the compact disc surfaces carefully

- Handle the compact discs so that fingerprints and dust do not adhere to the surface of the compact discs. Use a soft cloth for removal of any fingerprints or dust. Do not use a hard cloth, as this will mar the disc.

CHECK THE FOLLOWING BEFORE CALLING FOR SERVICE

Before you jump to the conclusion that it's out of order!

When the unit is not operating properly, one is apt to assume that the unit is faulty. There are, however, many possible faults which are not directly attributable to the unit itself. It is recommended to check the following before taking the unit to a Hitachi dealer.

Trouble	Cause	Remedy
Indicators do not turn on and no sound is heard with the Power/Operate button set to on "I".	<ul style="list-style-type: none"> • Insertion of power plug incorrect. 	<ul style="list-style-type: none"> ○ Check that the plug is inserted correctly.
Indicators turn on but no sound comes out.	<ul style="list-style-type: none"> • Knobs and switches are incorrectly set. • Connection of speaker is incorrect. 	<ul style="list-style-type: none"> ○ Read this instruction manual carefully and check that setting is correct.
When receiving an AM broadcast, continuous or intermittent noise occurs, and when tuning to a broadcast, tuning hum is generated.	<ul style="list-style-type: none"> • When electric appliances such as fluorescent lamps, motors (washing machine, vacuum cleaner, fan, sewing machine, hair drier, etc.) are used in the room or near the unit. • Hum at the tuning point is due to the broadcast signal. 	<ul style="list-style-type: none"> ○ Reverse the power plug. ○ Use an outdoor antenna. (Consult your local dealer.)
Noise occurs when listening to an FM broadcast. It is large especially at night and during weak broadcasts.	<ul style="list-style-type: none"> • Caused by noise (ignition noise) generated from ignition plug of car or automobile. • Medical equipment, a high frequency sewing machine, or high frequency welder is used near the unit. 	<ul style="list-style-type: none"> ○ Install an exclusive FM antenna away from road or cause of the noise, and adjust the direction of antenna. ○ Check that the antenna is installed correctly.
Sound does not come out from one loudspeaker.	<ul style="list-style-type: none"> • Speaker cords connected incorrectly. • Balance control is turned fully to one side. 	<ul style="list-style-type: none"> ○ Check connection of speaker cord. ○ Set the Balance control to center.
Howling occurs	<ul style="list-style-type: none"> • This occurs because of vibrations from the speakers affecting the turntable. 	<ul style="list-style-type: none"> ○ Move the loudspeakers and the unit further away from each other. ○ Reduce the volume. ○ Install the stereo system in a different place.
Sound fluctuates while listening to an FM broadcast.	<ul style="list-style-type: none"> • Effect of aeroplane flying near-by. 	<ul style="list-style-type: none"> ○ Leave it as it is for the time being. The unit is not malfunctioning. It will correct itself after a while.
Total track number of disc is not displayed.	<ul style="list-style-type: none"> • Disc is dirty. • Disc used is nonstandard. 	<ul style="list-style-type: none"> ○ Clean the surface of the disc. ○ Replace the disc.

Play button is pressed, but play does not begin.	<ul style="list-style-type: none"> • Disc is dirty. • Disc has scratches or is warped. 	<ul style="list-style-type: none"> ○ Clean surface of disc. ○ Replace disc.
A particular spot on the disc does not play correctly (sound cuts out, or same spot is repeated).	<ul style="list-style-type: none"> • Disc has scratch or other damage. • Disc is dirty. 	<ul style="list-style-type: none"> ○ Use the Fast forward search button to pass over the part scratched. ○ Clean the surface of the disc.
Position of musical instruments is not clean and bass does not come out during stereo.	<ul style="list-style-type: none"> • Polarity of loudspeakers is not correct. 	<ul style="list-style-type: none"> ○ Connect the speaker leads correctly paying attention to (+) and (—).
Cassette will not play.	<ul style="list-style-type: none"> • Tape jammed. 	<ul style="list-style-type: none"> ○ Removed and replace cassette.
Cassette plays but sound is distorted and quiet.	<ul style="list-style-type: none"> • Dirty tape heads. 	<ul style="list-style-type: none"> ○ Use cleaning cassette or head cleaner.
Record button cannot be depressed.	<ul style="list-style-type: none"> • Record tabs removed from cassette. 	<ul style="list-style-type: none"> ○ Tape up tab slots. Replace cassette.
Hum and buzz noise is heard from speakers when connecting a turntable and the Function PHONO.	<ul style="list-style-type: none"> • The ground wire of the turntable is not connected. • The power supply cord is close to the PHONO input jacks. 	<ul style="list-style-type: none"> ○ Connect the ground wire of turntable well. ○ Take the power supply cord away from the PHONO input jacks.

PRECAUTION

- Install the unit in a place free from direct sunlight and heat from a stove, etc.
- Choose a well ventilated, moisture-free place.
- Install the unit on a stable and vibration-free surface.
- Humming or noise may be caused by the influence of a turntable connected to this unit.
In such a case, try changing the arrangement of the equipment or the position of the wiring.
- Install the antenna correctly to improve the reception condition.
- To clean the cabinet and panels when they are dirty, clean off dirt on the surfaces with a dry cloth. Never use thinner, benzene or alcohol since these will damage the surface finish.
- Disc which can be played on this player have the following mark on them:



- For the set to operate at its best, it should not be subjected to temperatures below 5°C (41°F) or above 35°C (95°F).
- Do not move this unit suddenly from a very cold room into a warm room. When this chilled unit is moved suddenly to a warm location, moisture condensation may form on the pickup lens, preventing proper operation. In this case, wait 30 minutes before resuming play.
- The CD player has a wide dynamic range. As a result, if you turn the volume up too high during soft (low volume) parts of a program, your speakers may be damaged when the dynamic range of a sudden loud passage is produced.

SPECIFICATIONS

GENERAL

Power supply: AC: 120V, 60 Hz (U.S.A.)
AC: 240V, 50 Hz (U.K. and Australia)
Power consumption: 160W (U.S.A.)
250W (U.K. and Australia)
Dimensions: 621(W) x 133(H) x 368(D) mm
Weight: 8.5 kg
Supplied accessories: AM loop antenna (1)
FM dipole antenna..... (1)
Remote controller
(RB-W50)..... (1)

AMPLIFIER SECTION

Power output: 50 Watts* per channel,
(Both channels driven) min RMS, at 8 ohms from
70 Hz to 15 kHz, with less
than 0.9% total harmonic
distortion.

50 W/ch + 50 W/ch (8 ohms,
1 kHz, T.H.D. 0.7% SINUS)
50 W/ch + 50 W/ch (8 ohms,
1 kHz, T.H.D. 0.7%)

Total harmonic distortion: 0.5% (at 1/2 power output)

Input sensitivity/
impedance: PHONO: 3 mV/47 kohms
AUX: 90 mV/22 kohms

Load impedance: Speaker: 8 ~ 16 ohms
Headphones: more than 8 ohms

S/N ratio
(IHF A network): PHONO: 73 dB
AUX: 87 dB

TUNER SECTION

FM SECTION

Frequency range: 87.9 — 107.9 MHz (200 kHz
steps) (U.S.A.)
87.50 — 108.00 MHz (50 kHz
steps) (U.K. and Australia)
Sensitivity: 1.5 μ V (S/N 26 dB)
S/N ratio: MONO: 72 dB (IHF)
63 dB (IEC, un-
weighted, Q-peak)
60 dB (IEC, weighted,
Q-peak)
STEREO: 68 dB (IHF)
58 dB (IEC, un-
weighted, Q-peak)
55 dB (IEC, weighted,
Q-peak)

FM selectivity: 60 dB (\pm 300 kHz)
Stereo separation: 40 dB (1 kHz)
Antenna: Dipole antenna or external
antenna (75 ohms, unbalanced)

AM (MW) SECTION

Frequency: 530 — 1,710 kHz (10 kHz
steps) (U.S.A.)
522 — 1,611 kHz (9 kHz steps)
(U.K. and Australia)
Sensitivity: 40 μ V (S/N 26 dB)
S/N ratio: 50 dB
Antenna: Loop antenna or external
antenna

LW SECTION (For U.K.)

Frequency: 153 — 281 kHz (1 kHz steps)
Sensitivity: 400 μ V (S/N 26 dB)
Antenna: Loop antenna or external
antenna

TAPE DECK SECTION

Track system: 4 track 2 channel stereo
Recording system: AC bias
Tape: Normal, Chrome, Metal
Frequency response: Normal: 40 to 14,000 Hz
CrO₂: 40 to 15,000 Hz
Metal: 40 to 16,000 Hz

CD PLAYER SECTION

Playing time: Approx. 60 minutes/one side
Diameter: 120 mm
Sampling frequency: 44.1 kHz
Quantization number: 16 bit linear/channel
Frequency response: 20 to 20,000 Hz

Specifications and designs may be changed without
notice for improvement.

This appliance conforms to the requirements of
B.S. 800: 1983.

* Measured pursuant to the Federal Trade Commi-
sion's Trade Regulation Rule on Power Output
claims for Amplifiers

■ CONNECTION

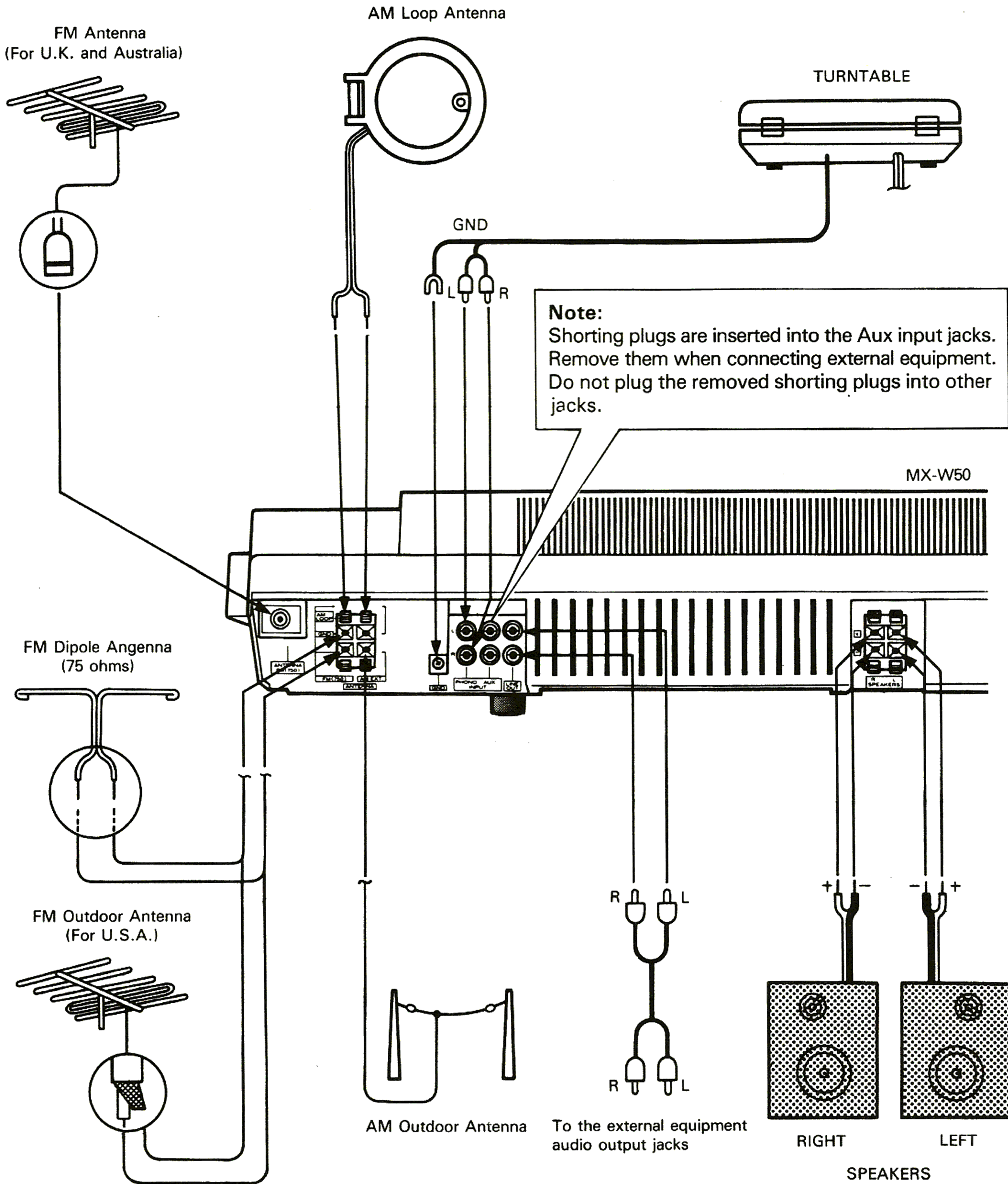

- This unit provided with terminals for loudspeakers. When connecting the speaker cords, push the red and black buttons on the speaker terminals and connect them without confusing (+), (-) and L, R.
- The speaker impedance suitable for the MX-W50 is 8 to 16 ohms and speakers with a suitable max. permissible input should be used.

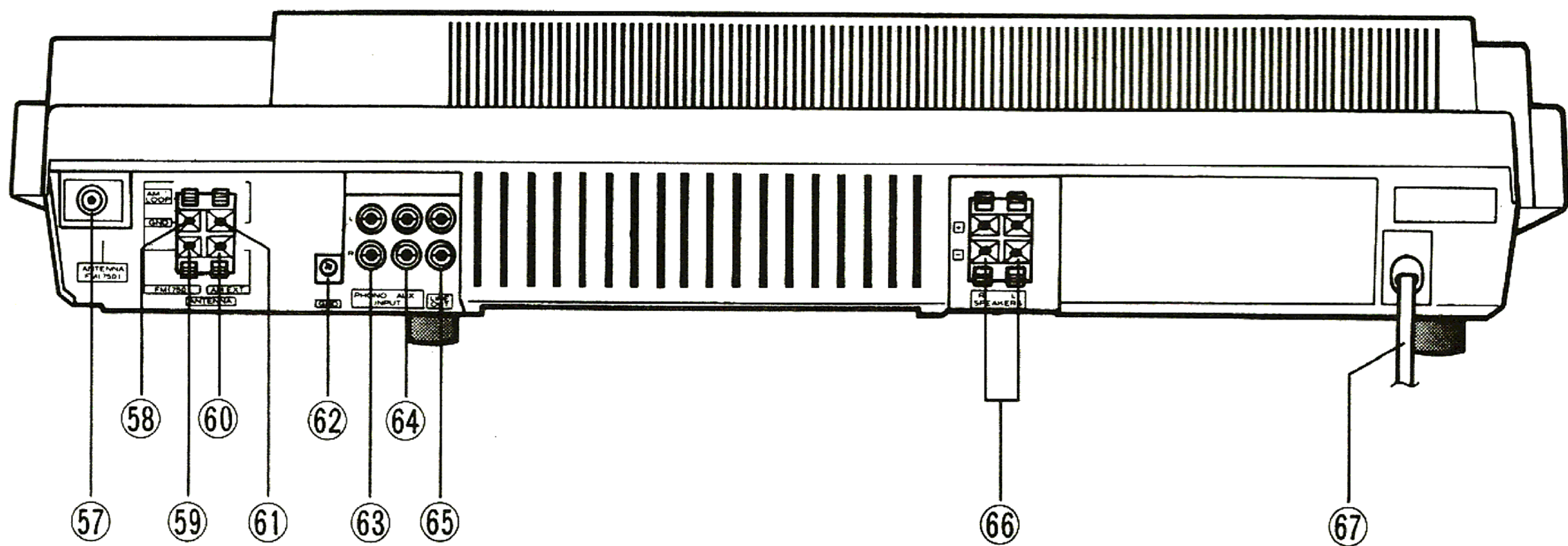
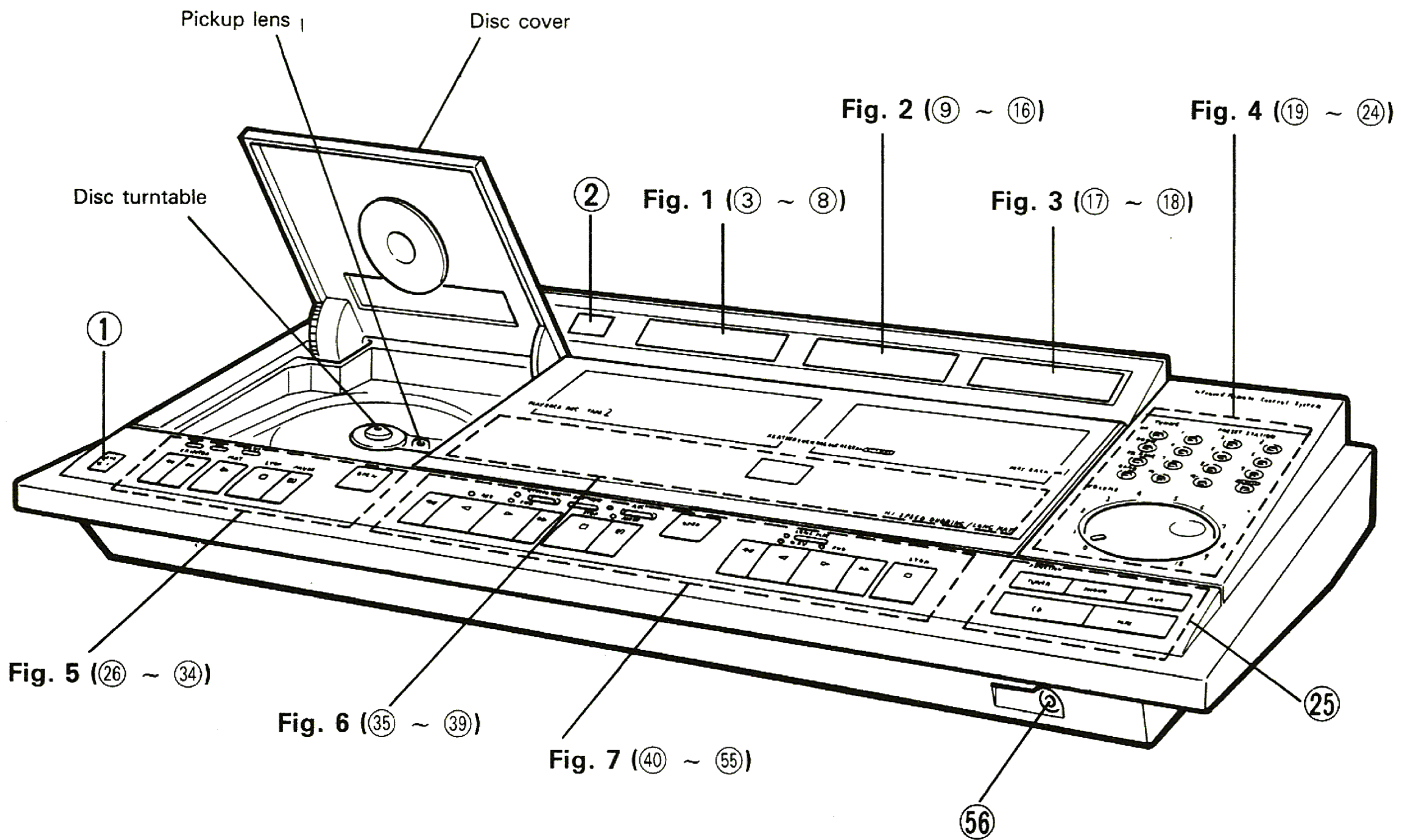

Fig. 1

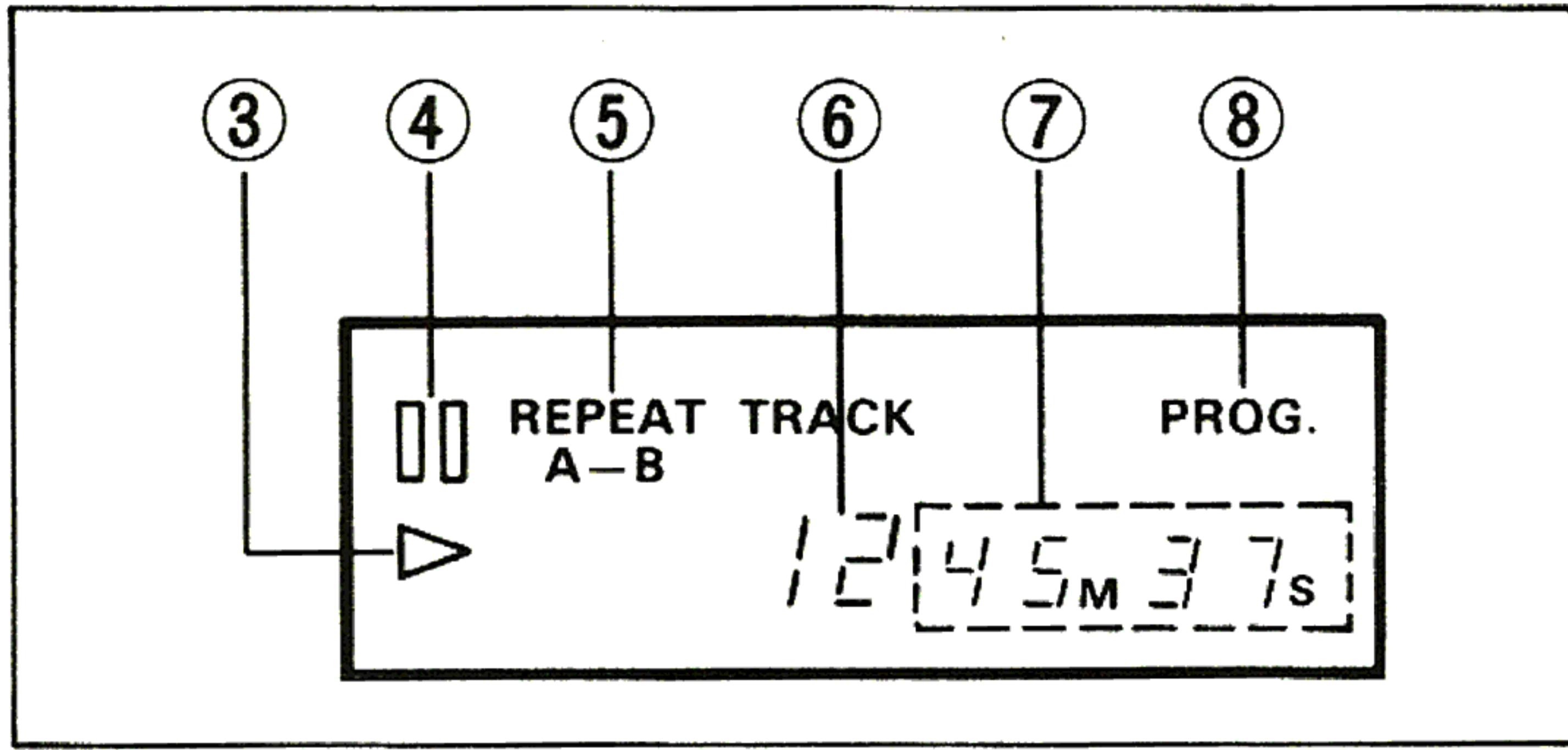

Fig. 4

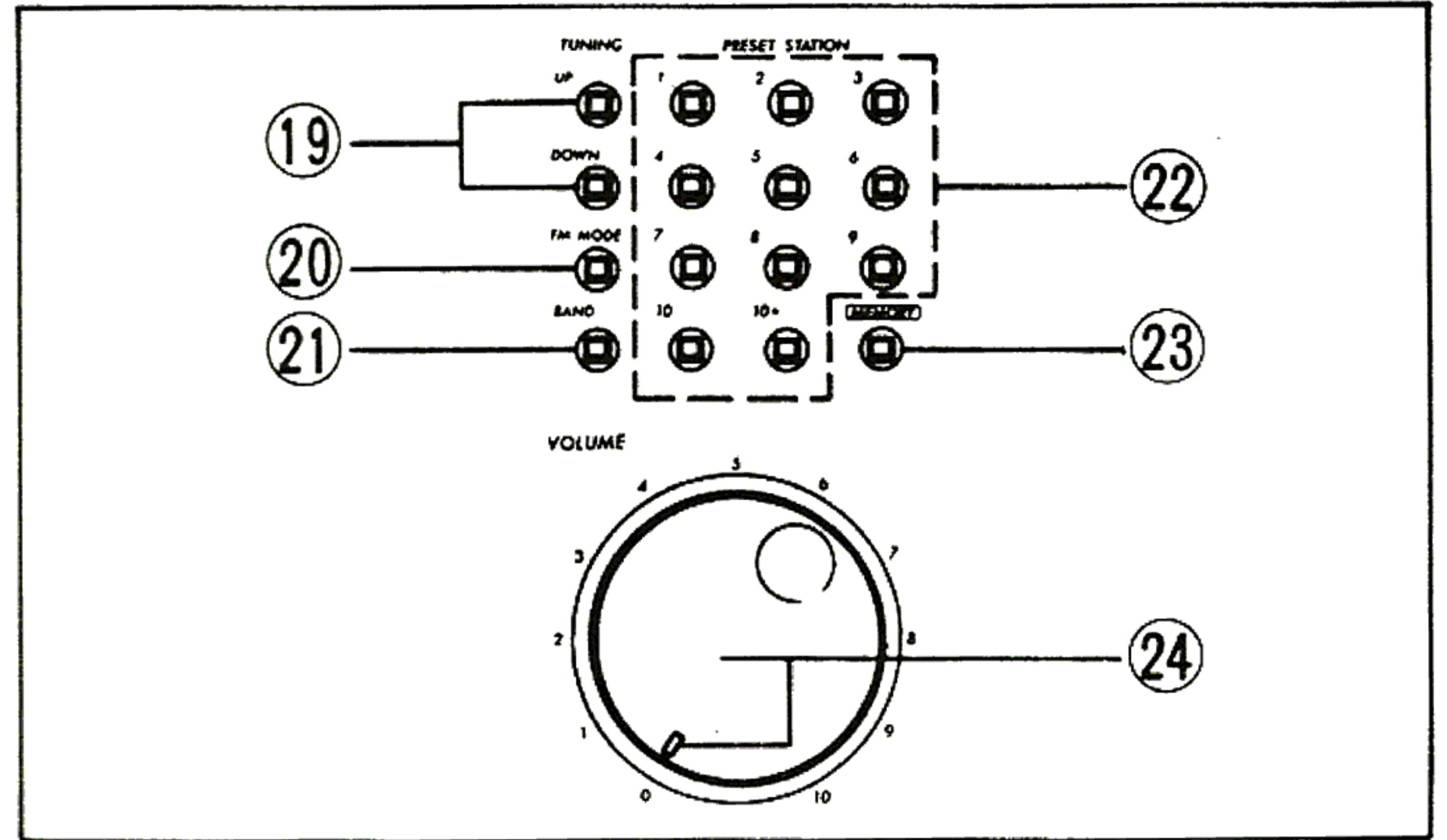

Fig. 2

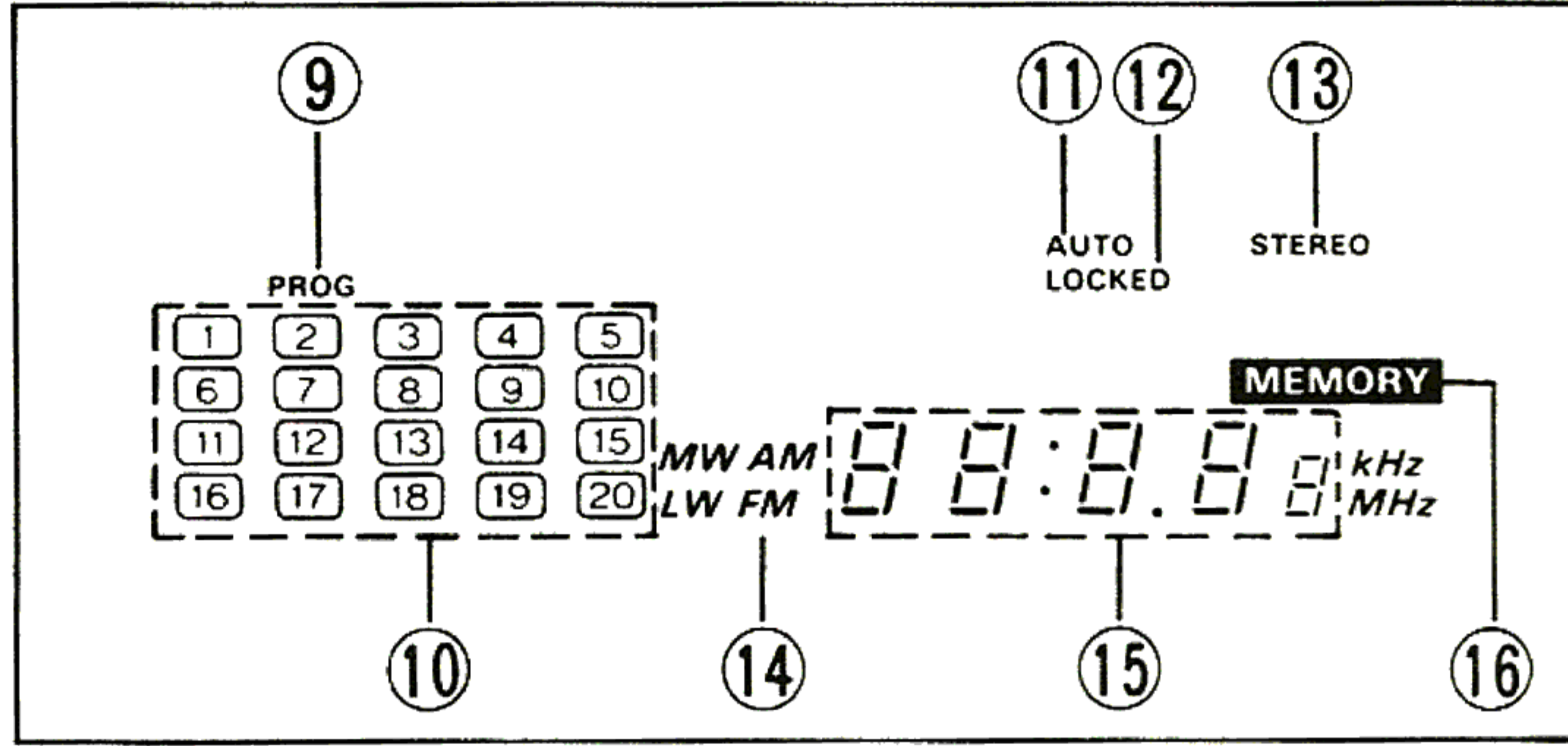

Fig. 5

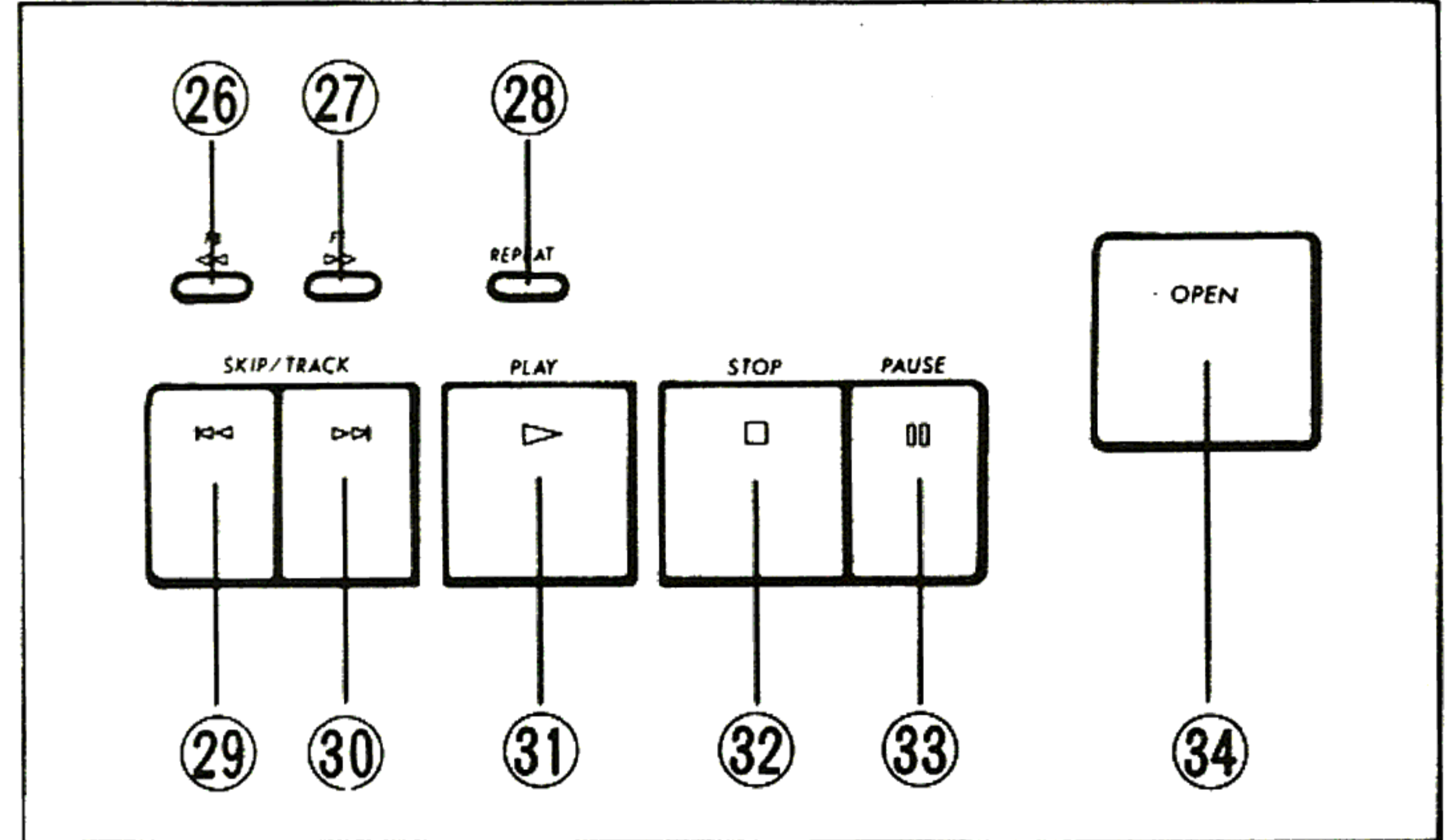

Fig. 3

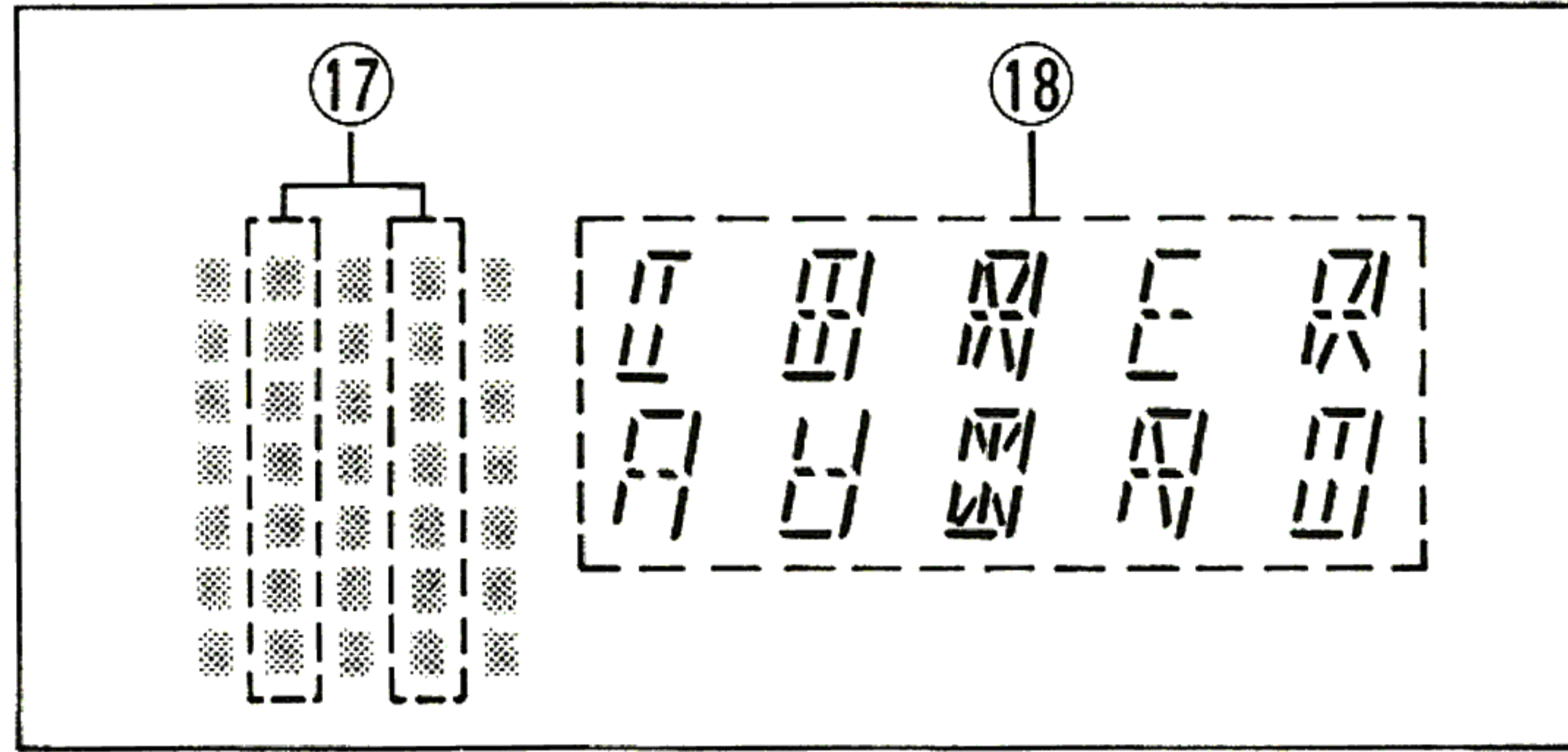

Fig. 6

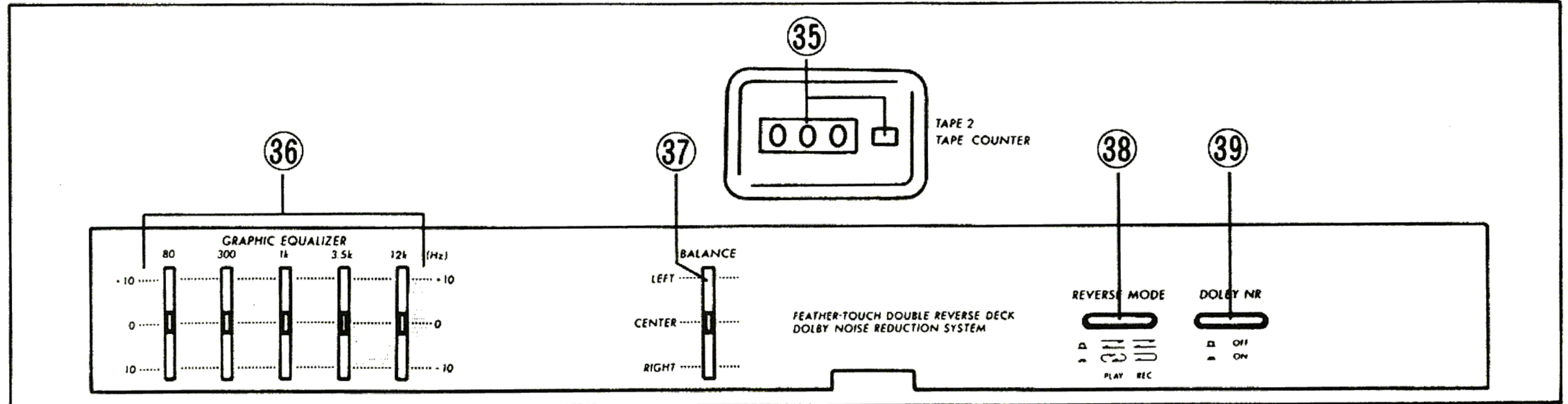

Fig. 7

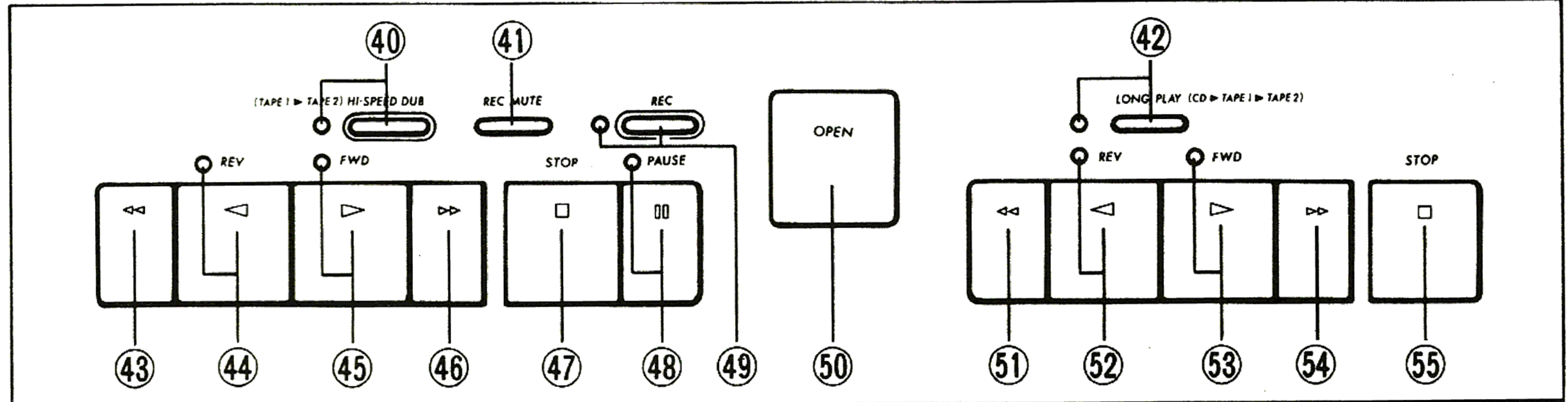

Fig. 8

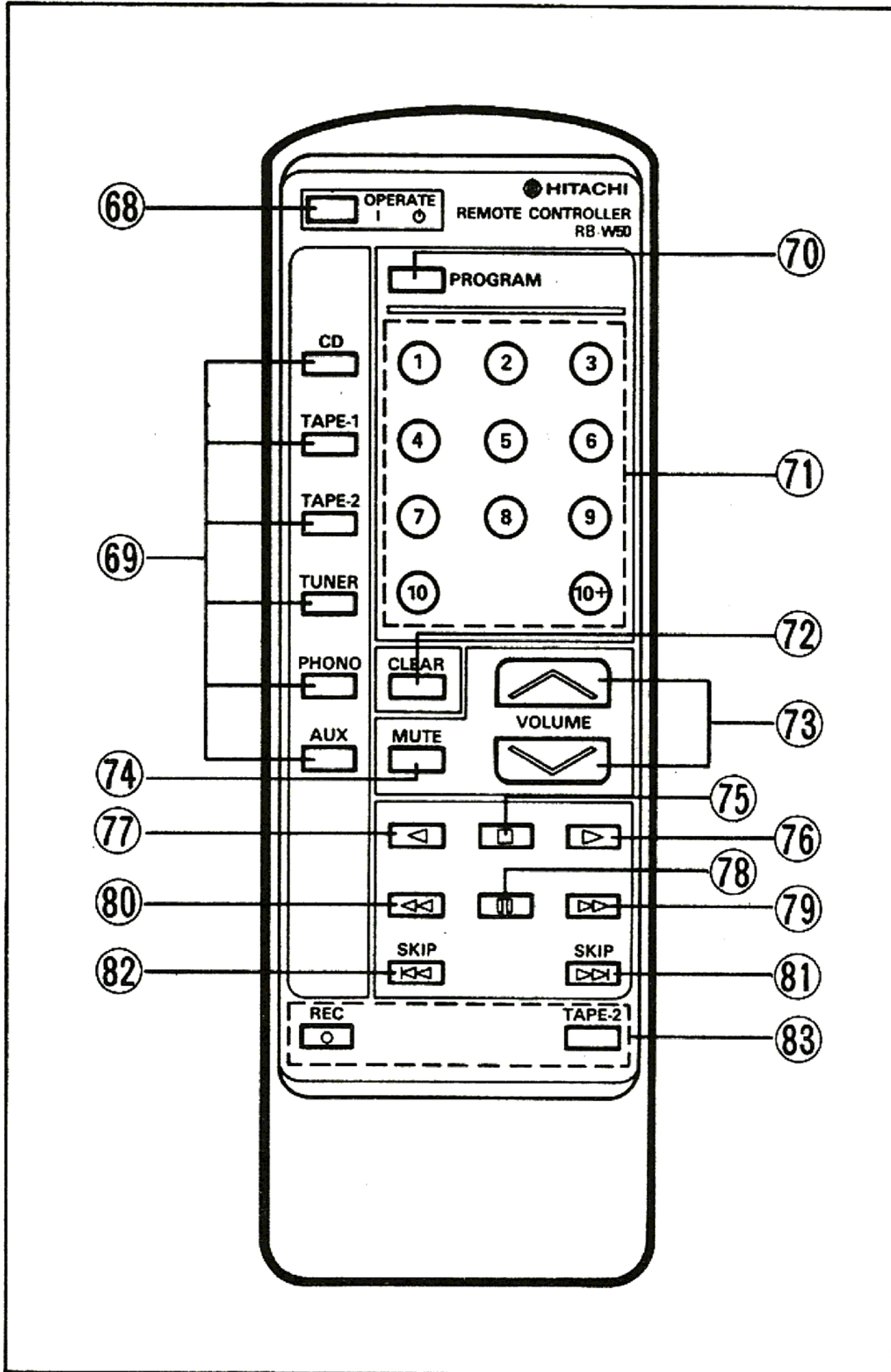

Fig. 11

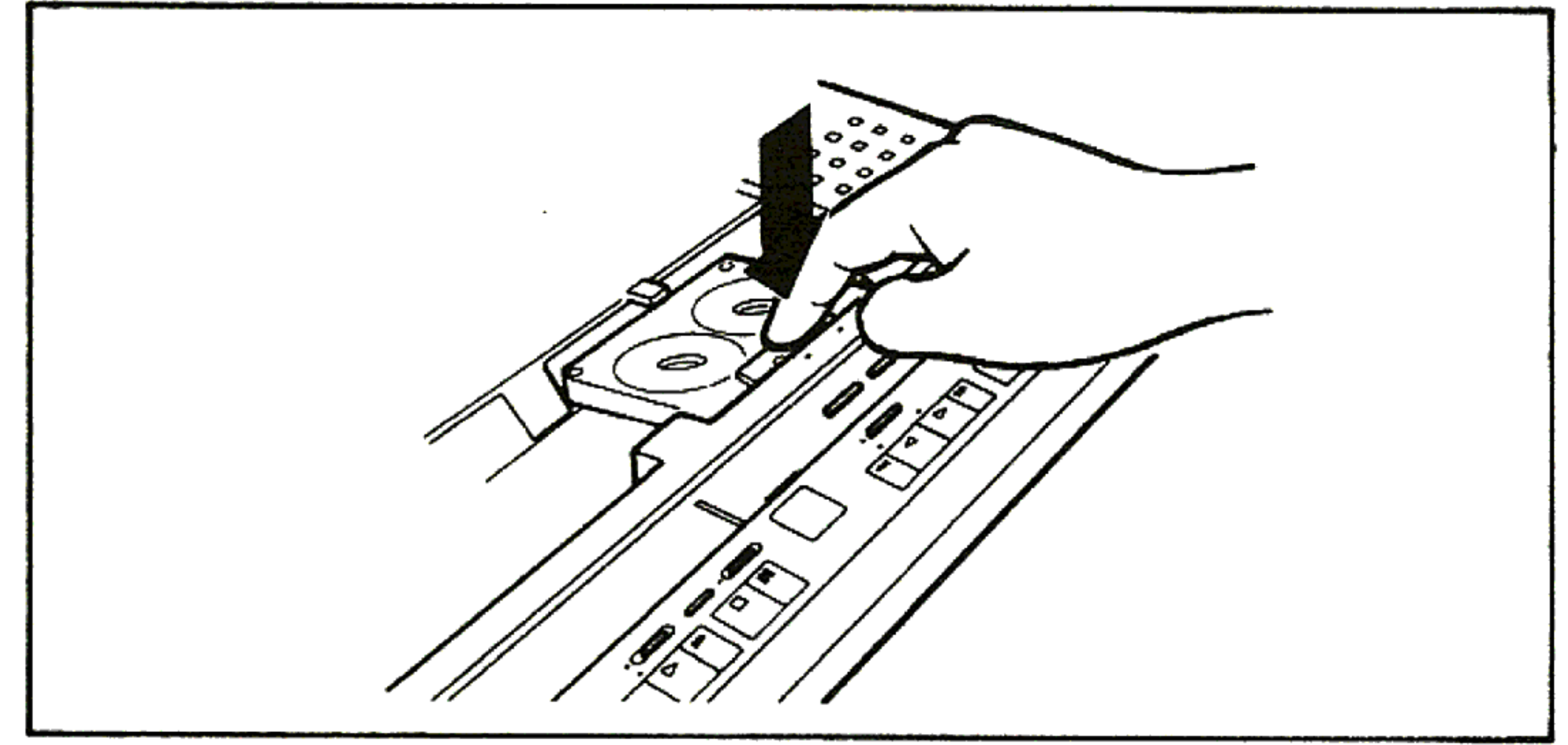

Fig. 12

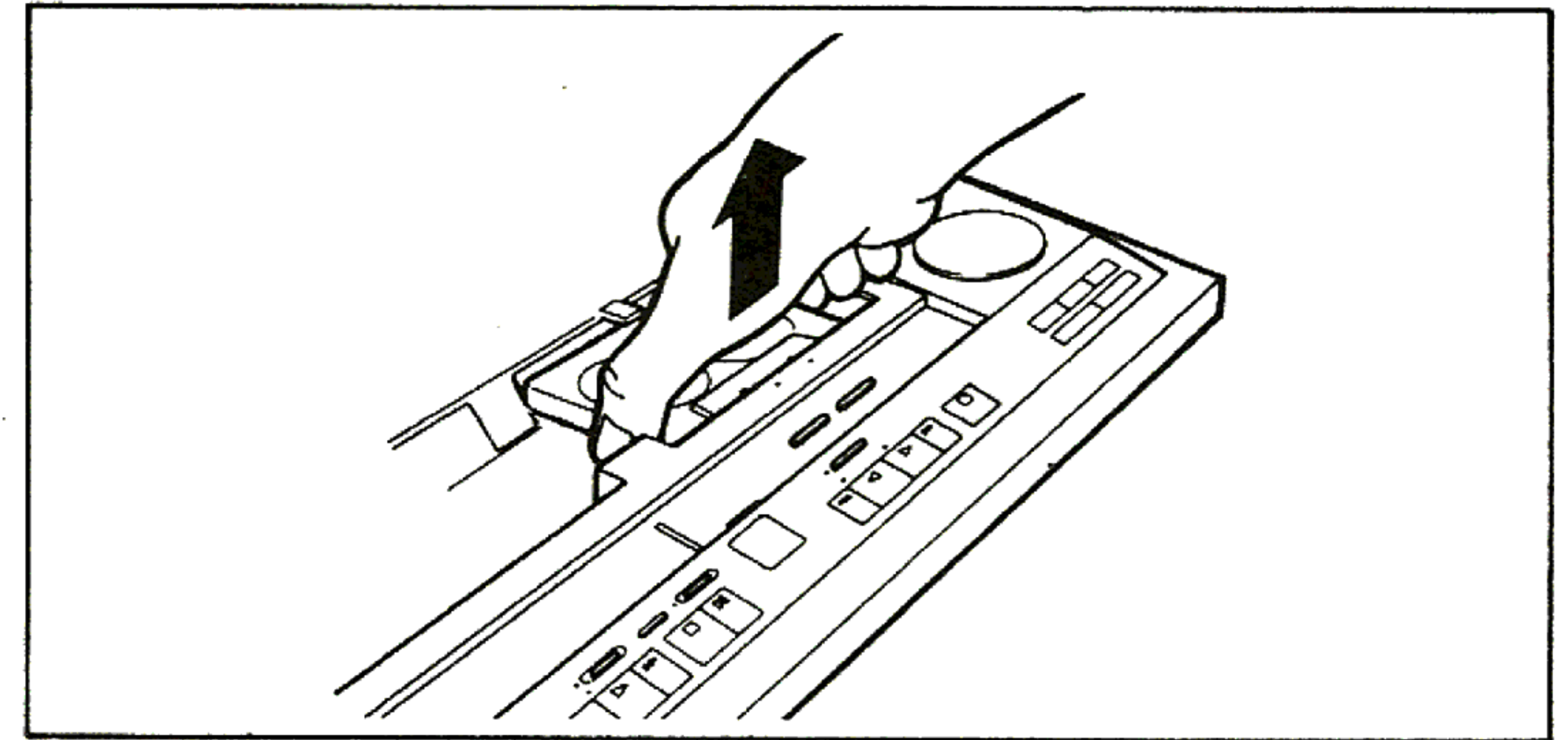

Fig. 13

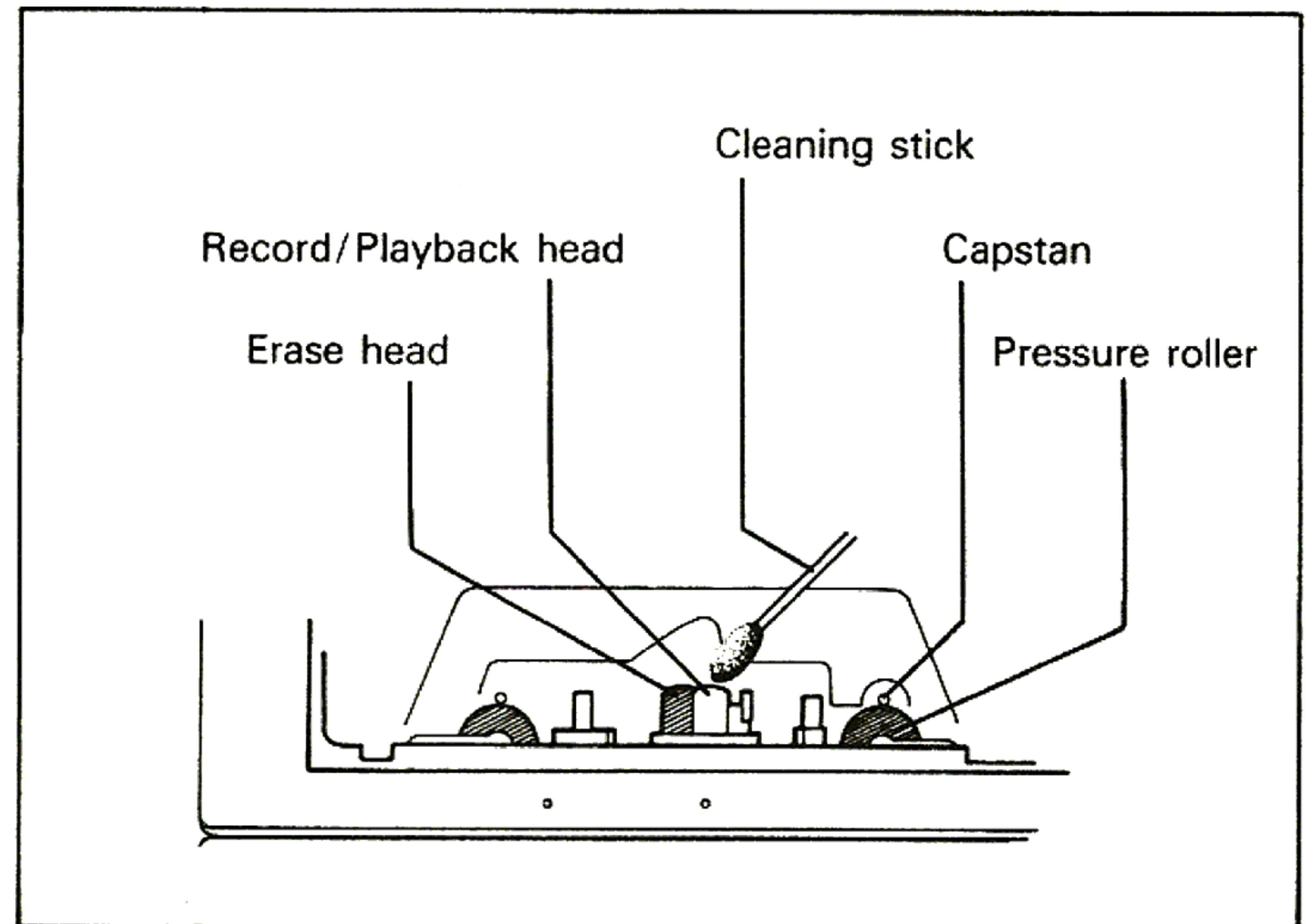

Fig. 9

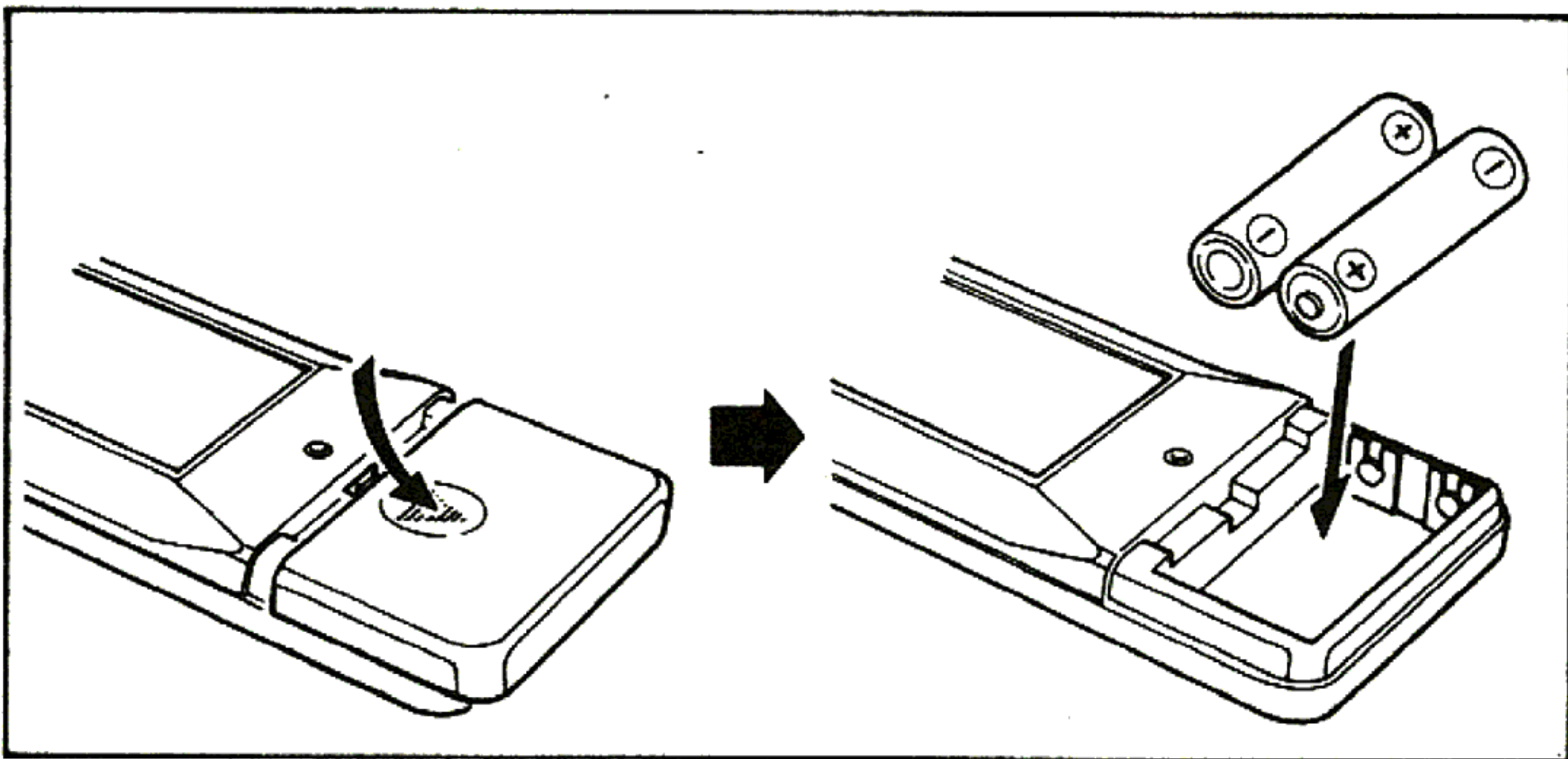

Fig. 10

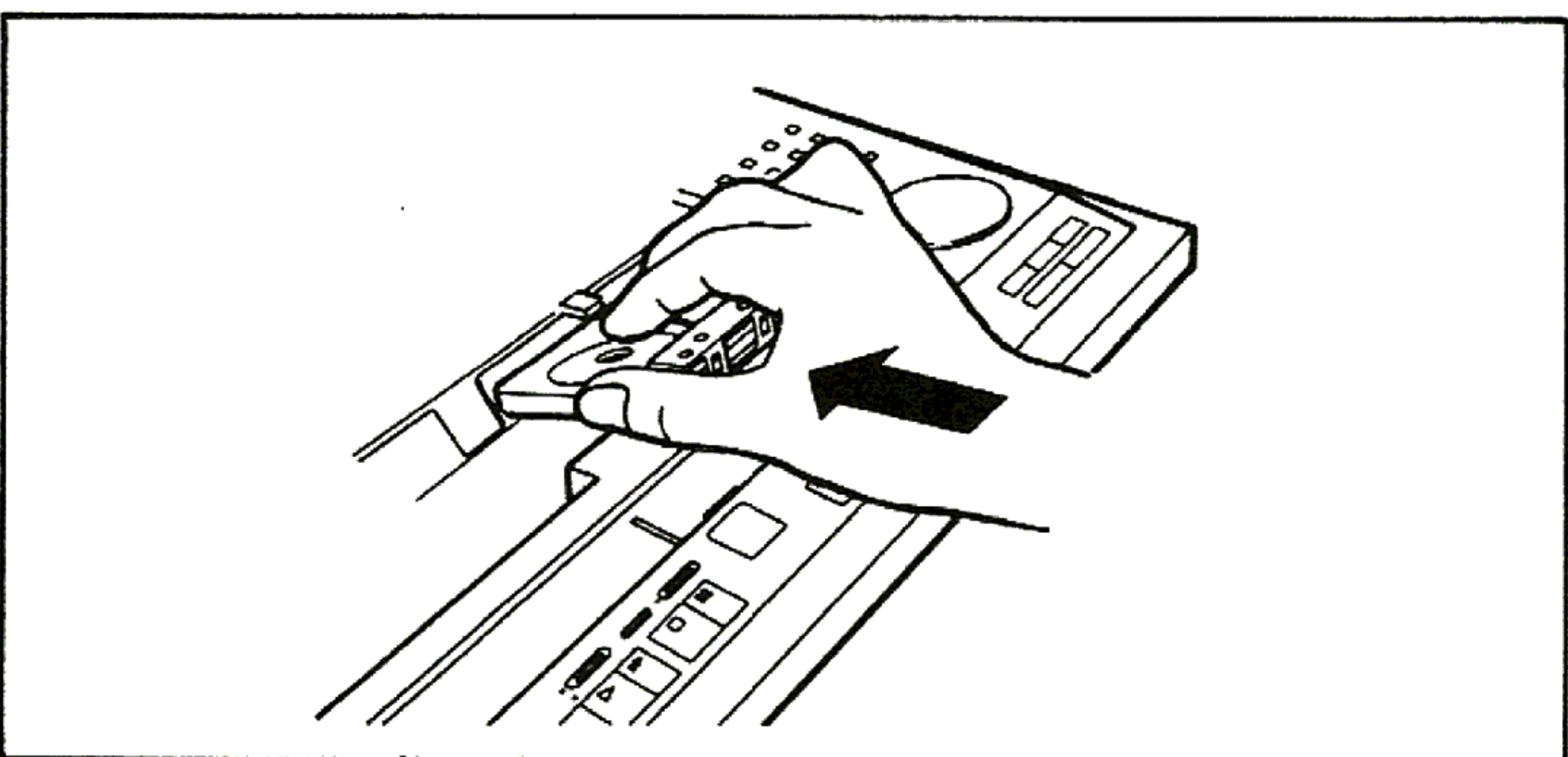
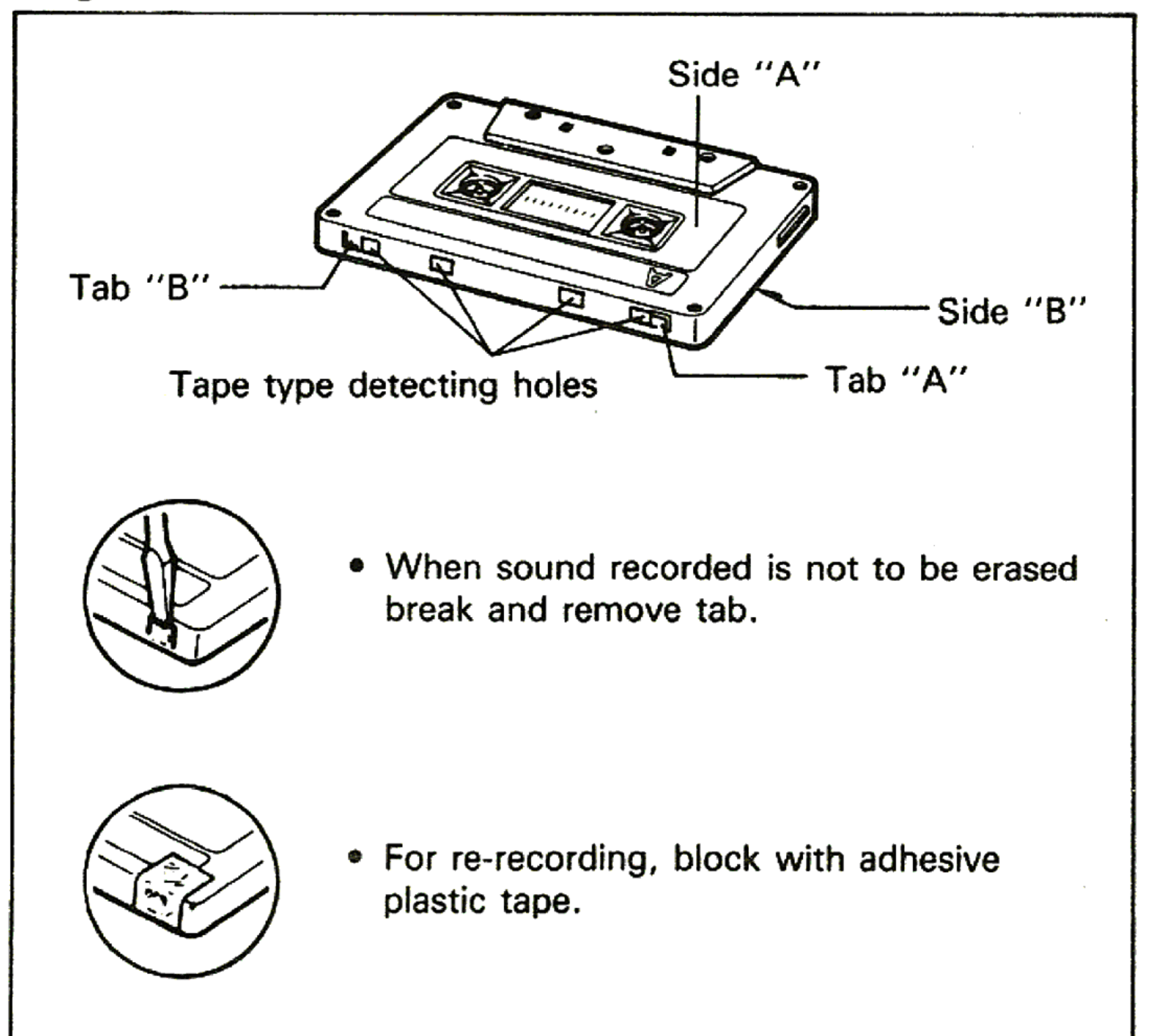

Fig. 14



WARNING LABEL

EXPLANATORY LABEL ON REAR-SIDE

CAUTION-INVISIBLE LASER RADIATION WHEN OPEN AND INTERLOCKS FAILED OR DEFEATED. AVOID DIRECT EXPOSURE TO BEAM.

AVOID EXPOSURE - LASER RADIATION IS EMITTED FROM THIS APERTURE.

For Europe and Australia, etc.

**CLASS 1
LASER PRODUCT**

For Europe and Australia, etc.

DANGER
Invisible laser radiation when open and inter lock failed or defeated. AVOID DIRECT EXPOSURE TO BEAM.

For U.S.A.

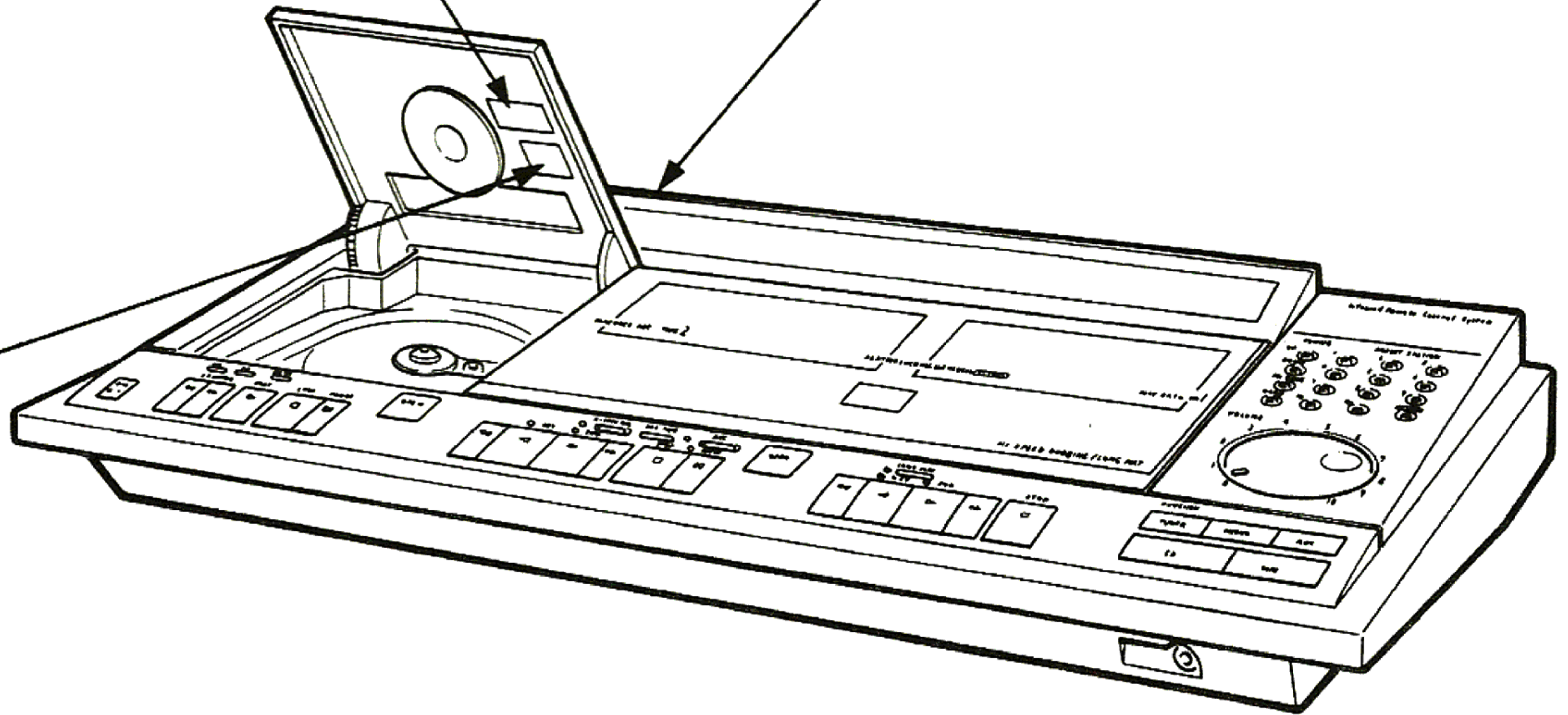

THIS LASER COMPACT DISC PLAYER FUNCTIONS BY HELP OF INVISIBLE LASER LIGHT AND IS EQUIPPED WITH SAFETY SWITCHES TO AVOID EXPOSURE WHEN DOOR IS OPEN AND SAFETY INTERLOCKS ARE DEFEATED. IT IS DANGEROUS TO SET SAFETY-SWITCHES OUT OF FUNCTION. THERE ARE NO USER'S SERVICEABLE PARTS INSIDE THE UNIT, LEAVE ALL SERVICE TO QUALIFIED SERVICE PERSONNEL.



Head Office : THE HITACHI ATAGO BLDG.
No. 15-12, 2-chome, Nishi-Shinbashi,
Minato-ku, Tokyo 105, Japan
Tel: Tokyo (03) 502-2111