

FIG 1.1.1. FRONT PANEL OF SIGNAL GENERATOR

NSN 6625-99-972-6000 SIGNAL GENERATOR (2-250 MC/S) CT379A

SUMMARY OF DATA

PURPOSE

Simple testing of radar and communications receivers.

BRIEF DESCRIPTION

NOTE: CT378A differs from -943-1825 CT378 in that its frequency is extended to 250 Mc/s and an additional power supply is included for use with pulse modulator.

This signal generator provides signals between 25 mV and 1 μ V into a 75 ohms load at any radio frequency between 2 and 250 Mc/s. An external attenuator unit is used when working into 50 ohm loads; signals between 12.5 mV and 1 μ V are then available. The seven frequency ranges are so chosen that common radar i.f. amplifiers etc. can be checked for centre frequency and bandwidth without range changing. An internal 1 kc/s tone generator and optional squaring stage provide a nominal 30 per cent amplitude modulation, with either sine or square waveform at any radio frequency within the range. External sine wave and pulse modulation are also possible. The modulation circuits are of novel design to reduce frequency modulation to negligible proportions for normal measurements. The second harmonic of range G is calibrated for use between 170 and 500 Mc/s.

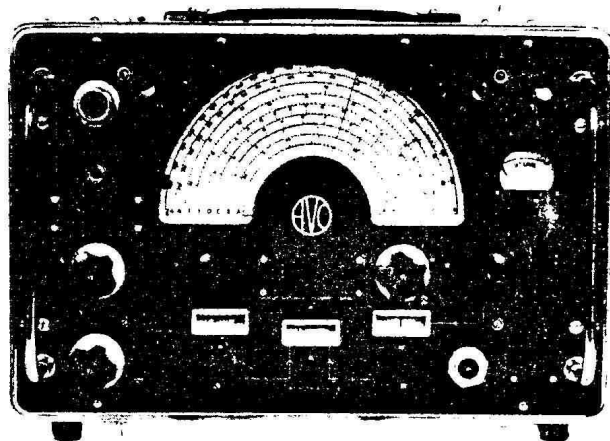

For Service Manuals Contact
MAURITRON TECHNICAL SERVICES
8 Cherry Tree Rd, Chinnor
Oxon OX9 4QY
Tel:- 01844-351694 Fax:- 01844-352554
Email:- enquiries@mauritron.co.uk

PERFORMANCE

<u>Ranges</u>	
Range A	2-4.5 Mc/s
Range B	4-9 Mc/s
Range C	7.5-16 Mc/s
Range D	11.24 Mc/s
Range E	22-50 Mc/s
Range F	45-100 Mc/s
Range G	85-250 Mc/s

GENERAL VIEW OF CT378A

Harmonic Range 2G 170-500 Mc/s.

Scale calibration accuracy ± 1 per cent ± 2 per cent at scale extremes.

Output

Output into 75 ohms, 1 μ V to 25 mV continuously variable; into 50 ohms, 1 μ V to 12.5 mV using fixed attenuator.

Accuracy ± 2 dB ± 1 μ V up to 150 Mc/s

± 3 dB ± 2 μ V 150-250 Mc/s

Harmonic range - the level is approximately 10 per cent of that indicated.

CHAPTER 1TECHNICAL DESCRIPTIONIntroduction.

1. The Signal Generator CT378A is a general purpose Signal Generator which has been designed to produce a 30% a.m. signal having an f.m. content not greater than 5 kc/s. The tuning mechanism has been built to enable the instrument to be used in conjunction with radio receivers having a 10 kc/s passband, and both the attenuator and stray field have been required to meet an exacting specification. This instrument incorporates a new form of attenuator using a printed circuit technique, to give negligible reaction with change of frequency. In conjunction with a plug-in modulator unit, pulse modulation is also available.

Panel Controls and Frequency Coverage

2. Eleven controls are provided, together with a MAINS 'ON-OFF' switch. Their respective functions are as follows:-

The RANGE Mc/s switch

3. This is a seven-position switch marked:

A	-	4.5	-	3
B	-	9	-	4
C	-	16	-	7.5
D	-	24	-	11
E	-	50	-	22
F	-	100	-	40
G	-	250	-	85

The position of this control indicates the band in Mc/s over which the instrument is set to operate, the upper and lower limit of each band also being displayed on the main scale plate adjacent to each section of the calibrated scale.

In addition, when the switch is set to G - 250 - 85, the harmonic range 2G covering 500-170 Mc/s may also be used. In general, it should, however, only be used as a harmonic range for frequencies above 250 Mc/s i.e. 2×125 Mc/s.

The TUNING CONTROL

4. This control operates the main capacitor, which is directly coupled to the cursor, which sweeps the calibrated frequency dial. There is, therefore, no possibility of errors being introduced due to backlash between capacitor and cursor.

5. The complete frequency range of the instrument is 2 - 500 Mc/s covered in eight bands as follows:-

A - 4.5 Mc/s - 2 Mc/s	Calibrated sub-divisions at mid-scale are marked at intervals of 50 kc/s.
B - 9 Mc/s - 4 Mc/s	Calibrated sub-divisions at mid-scale are marked at intervals of 100 kc/s.
C - 16 Mc/s - 7.5 Mc/s	Calibrated sub-divisions at mid-scale are marked at intervals of 100 kc/s.
D - 24 Mc/s - 11 Mc/s	Calibrated sub-divisions at mid-scale are marked at intervals of 200 kc/s.
E - 50 Mc/s - 22 Mc/s	Calibrated sub-divisions at mid-scale are marked at intervals of 0.5 Mc/s.
F - 100 Mc/s - 40 Mc/s	Calibrated sub-divisions at mid-scale are marked at intervals of 1 Mc/s.
G - 250 Mc/s - 85 Mc/s	Calibrated sub-divisions at mid-scale are marked at intervals of 1 Mc/s.
Harmonic range 2G - 500 - 170 Mc/s ...	Calibrated sub-divisions at mid-scale are marked at intervals of 2 Mc/s.

The ENGAGE FINE CONTROL and FINE CONTROL

6. The TUNING CONTROL is fitted with a knurled ring labelled ENGAGE FINE CONTROL which when tightened down in a clockwise direction enables movement of the FINE CONTROL to be transmitted by a vernier drive to the main capacitor via the TUNING CONTROL. The FINE CONTROL operates an interpolation dial, which can be observed through a window adjacent to the TUNING CONTROL. If the knurled clamping ring on the TUNING CONTROL is turned in a counter-clockwise direction, the FINE control and dial are disengaged. The frequency range can then be scanned at high speed by means of the TUNING CONTROL.

The SHIFT SCALE and LOCK SCALE Controls

7. Despite the extremely wide frequency coverage of the instrument, the accuracy of the calibrated frequency scale is, at mid-scale, within $\pm 1\%$. This degree of accuracy is not however sufficient to enable the scale to be set to within a small fraction of a megacycle at 200 Mc/s, or within 10 kc/s at 5 Mc/s. The instrument has therefore been fitted with a device which enables the scale to be moved with respect to the cursor, enabling the calibration at any point to be precisely set, by beating the output of the signal generator against a signal of a known frequency. This precise scale setting can then be locked and subsequent frequency settings made in the region around the set point to a very high degree of accuracy.

8. The scale can be freed by turning the LOCK SCALE knob in a counter-clockwise direction and then moved with respect to the Cursor by turning the SHIFT SCALE control to give the frequency setting required. The scale is then locked by turning the LOCK SCALE knob in a clockwise direction.

9. When it is desired to return the instrument to its original calibration setting, the scale can be freed by means of the LOCK SCALE knob, and the scale moved by means of the SHIFT SCALE control until the reset mark on the scale plate is located in the centre of the small viewing aperture provided. The scale is then locked by turning the LOCK SCALE knob in a clockwise direction.

The FUNCTION and MOD SWITCHES

10. The FUNCTION SWITCH is a four-position switch marked:-

- | | | |
|---------------------|------|---|
| (1) A.F. (C.W. off) | | The r.f. oscillator is quiescent and the internal tone oscillator (1000 c/s) is used to produce 4-5V r.m.s. from the source impedance of about 10,000 ohms across the 'A.F. OUT' and '↓' terminals. |
| (2) C.W. | | Unmodulated r.f. carrier. |
| (3) INT. A.M. | | R.F. carrier modulated at a nominal depth of 30% by the internal 1000 c/s tone generator. |
| (4) EXT. A.M. | | R.F. carrier can be amplitude modulated to a depth not exceeding 50%, by applying a modulation voltage to the terminals 'EXT. A.M. IN' and '↓'. The input impedance is about 1 M ohm in parallel with 20 pF. A nominal modulation depth of 30% is given by a sine wave of about 6V r.m.s. at any frequency between 100 c/s and 10 kc/s. |

NOTE: In positions 3 and 4 the modulation signal is available between the 'A.F. OUT' and '↓' terminals and can thus be conveniently used to lock an oscillograph time base, but the circuit must not be heavily loaded. When so used, the load employed should not drop below 50 k. ohms, for otherwise the modulation depth of the r.f. signal may be altered and/or spurious f.m. introduced on to the carrier.

The MOD switch either selects the sine wave oscillator for driving the modulator or else introduces a simple squaring circuit between the oscillator and modulator.

The R.F. ATTENUATOR controls

11. The attenuator is divided into sections, COARSE and FINE, the setting of each control being visible through a centre window, the dials working in juxtaposition.

12. The COARSE dial is marked 'FORCE, X1mV, X0.1 mV, X 10 μV, and X 1μV. The FINE dial is marked 'FORCE, 25, 20, 15, 10, 7.5, 5, 4, 3, 2, 1.' A minor calibration point is put in at 3.16 equivalent to 10dB on the "1" point.

13. To obtain FORCE output from the signal generator, the force calibration points on both dials, must be placed adjacent to one another. When the COARSE dial is set to its remaining positions, then any setting of the FINE dial between 25 and 1 when multiplied by the COARSE dial setting, gives the output from the r.f. cable (when terminated by 75 ohms) after adjustment of the SET LEVEL control. When a 50 ohm source impedance is required a 5905-99-972-6357 attenuator, fixed, containing a 75 ohm load and a 12.5 ohm series resistor should be used. See operating instructions.

The SET LEVEL control

14. When using the signal generator on the ranges 'C.W.' 'INT. A.M.' or 'EXT. A.M.', the output level required should be set on the R.F. ATTENUATOR controls and the SET LEVEL control turned until the set level meter needle is set at the datum mark on the scale plate. The output from the r.f. cable, when terminated with a load of 75 ohms, will then be as indicated on the R. F. ATTENUATOR control. When used with 5905-99-972-6357 ATTENUATOR, FIXED, for 50 ohm loads, the indicated voltage should be divided by a factor of two.

CIRCUIT DESCRIPTION

The R.F. Oscillator Circuit

15. This is a modified Colpitt's circuit employing a high-slope triode valve V3, delivering approximately 200 mV at the junction of R19, R15 and MR1 into a novel form of constant impedance modulator and attenuator system.

16. The amplitude of the r.f. signal delivered into the modulation system, can be adjusted by the panel control RV3 which limits the anode voltage fed to V3. The amplitude of the r.f. signal is adjusted to 400 mV by placing a high impedance valve voltmeter across R36 and L16a, when the range control is set to A - 4.5 - 2 Mc/s. The resistor R36, plays no part in the function of the r.f. circuit, but is inserted to enable the SET COMPENSATION Control to be adjusted. When RV3 has been correctly adjusted, the valve voltmeter circuit, C21, MR3, R31, C26, R33, C27, and R32, is so adjusted that the indicator needle of M1 reads on the graduation on the scale, by selecting the value of R.32.

17. Resistor R37 is inserted when SAa is set to its A.F. 'C.W. OFF' position. When SAa is so set, the r.f. oscillator ceases to operate and the dummy load R37 maintains a constant load on the power pack. This loading prevents a surge of r.f. when switching from A.F. (C.W. OFF) to C.W.

The Tone Generator

18. This is a simple Hartley oscillator employing V1B and remains in operation except when SA is set to 'EXT. A.M.' This stage is supplied with anode voltage direct from L6 which is fed to the centre-tapped choke L1. The a.f. output is fed via C3 to SAB and the function of this switch should be noted in relation to SAa to which it is of course directly ganged. The functions of the switch are given below:-

19. A.F. (C.W. Off) - The a.f. signal is fed to the grid of V1A which acts as a cathode follower delivering an a.f. output of about 4 to 5 volts r.m.s. via C14 to the a.f. output terminals. Note that the r.f. oscillator is quiescent, and there is therefore no output via the attenuator.

20. C.W. - No a.f. signal is applied to V1A, the grid of which is shorted. An unmodulated r.f. signal can be obtained from the r.f. cable.

21. INT. A.M. - an a.f. signal is fed into the grid of V1A from whence two outputs are taken into the modulation system (to be described) which produces an r.f. signal, amplitude modulated at 1000 c/s to a depth of 30%. If the MOD switch is put at square, valve V5 is introduced into circuit giving a substantially square-wave output which is fed on to the modulator.

22. EXT. A.M. - The a.f. input terminal is connected to the grid of V1A and thus an outside a.f. source can be used to modulate the r.f. signal via the anode and cathode stages of V1A which feeds into the modulation network. The internal tone generator is muted by SAd to avoid spurious a.f. pickup from this source. A voltage of about 6V r.m.s. produces a nominal 30% modulation. Modulation up to about 60% is available without appreciable distortion. The internal square-wave generator is inoperative.

The Modulation System

23. This is a novel and ingenious form of modulation network, designed to reduce to a minimum the variation of load imposed on the r.f. circuit. (Patent Applied for).

24. Consider a simple r.f. generator coupled to a variable load, which is imposed on the r.f. circuit in the form of an amplitude modulated signal. Alterations in the load will be reflected back to the generator, which sees the load as a variable impedance, which does, of course, mean that the frequency of the signal produced by the r.f. circuit may tend to change. This phenomenon is of little consequence when designing simple signal generators for aligning ordinary broadcast receivers, but it cannot be tolerated in an instrument such as this, for an amplitude modulated r.f. signal may be produced having a frequency modulation content greater than the band-width of the 10 kc/s i.f. channels into which the instrument is designed to inject a signal.

25. The problem has therefore been to design a circuit to give amplitude modulation signals with a minimum of frequency modulation content. This has been done by employing the following method, bearing in mind that the essential task is to impose a constant load on the r.f. circuit. Suppose that an r.f. circuit (Fig. 1.1.2) is loaded by the potentiometer RV, then variations of RV will impose a variety of loads on the coupling circuit, thus pulling the generator.

R.F. Circuit Feeding Variable Load

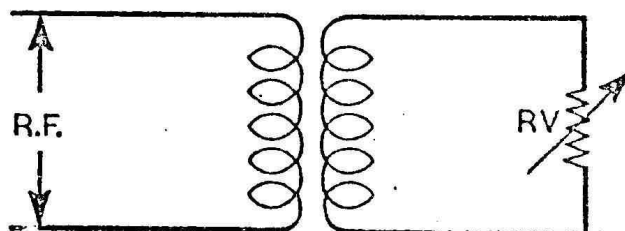

(Fig. 1.1.2)

26. Suppose however that the circuit is rearranged as in Fig. 1.1.3, using two identical potentiometers ganged in such a manner that movement of the control increases the value of one by the same amount as it decreases the value of the other - then the value of the load will be constant. This is the principle adopted in this instrument, but instead of using an impracticable arrangement of potentiometers to keep the load (in practice an amplitude modulated output) constant, germanium crystals have been employed.

R.F. Circuit Feeding Constant Load

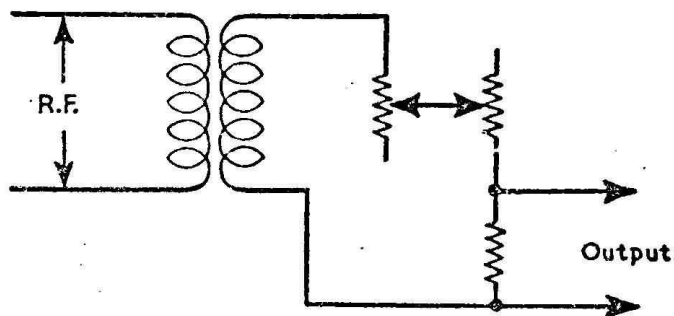

(Fig. 1.1.3)

27. Consider the simplified modulation circuit Fig. 1.1.4. The approximately 200 mV r.f. signal is fed to the two potential dividers R1, R2, R3, and R4. With no a.c. input at points A & B, but with fixed d.c. bias applied to the crystals MR1 and MR2, these potential dividers, together with their associated circuitry, present a constant load to the r.f. generator.

Simple Modulation System

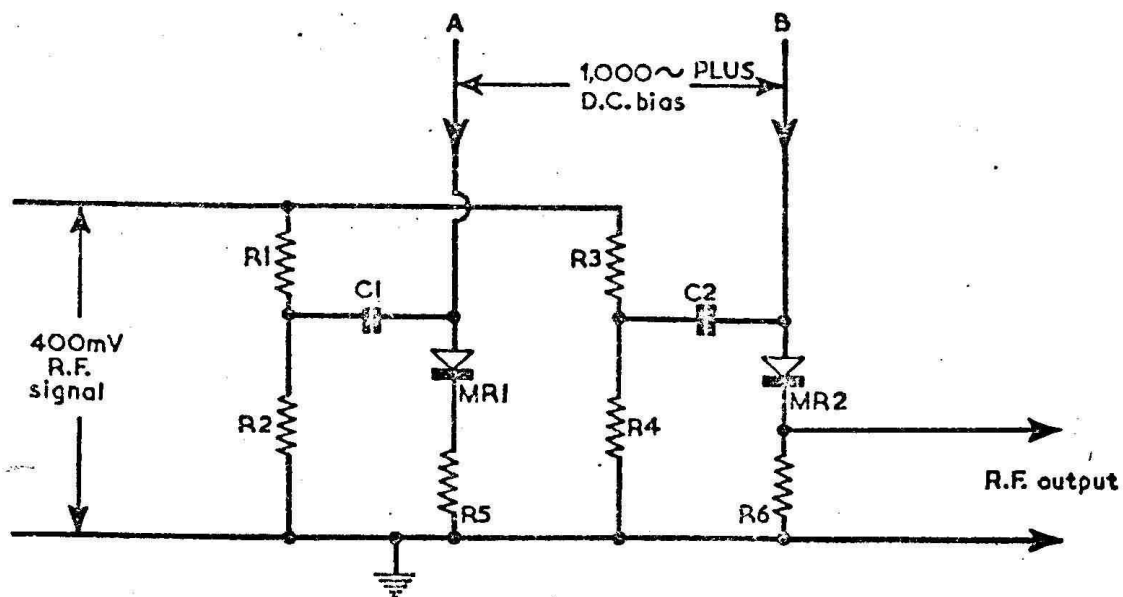

(Fig. 1.1.4)

28. Consider now the current-resistance characteristic of one of the germanium rectifiers MR1 or MR2 (Fig. 1.1.5) and, for the purpose of explanation, assume that the two functions have a linear relationship (the graph is a straight line), the resistance of the rectifier varying with the current passing. If the current rises, the resistance falls and conversely, if the current falls, the resistance rises. If therefore a nominal working point is selected at about 1 mA, the resistance of the device will be constant, but if then a sinusoidal waveform is applied on top of the d.c. bias, then the resistance of the device will vary in sympathy with the applied waveform. Thus the variable resistance device shown in Fig. 1.1.2 has been produced electronically.

Graph showing change of crystal resistance with current

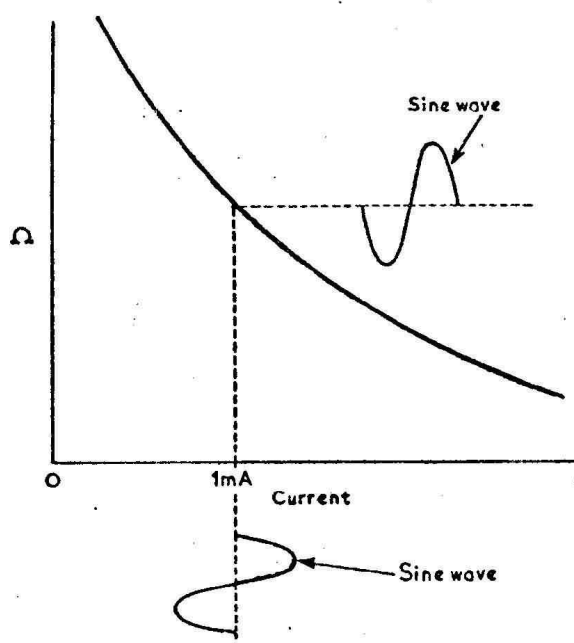

(Fig. 1.1.5)

29. Consider once again the modulation circuit shown in Fig. 1.1.4. With a constant d.c. bias, the load on the r.f. generator is constant, but if now a 1000 c/s waveform is applied at points A & B, these points being fed in anti-phase, it can at once be seen that one crystal tends to conduct more heavily, whilst the other cuts off to the same degree. Thus the device still maintains a constant load on the r.f. generator.

30. It must now be realised that in the practicable circuit, the 1000 c/s bias carries a relatively smaller r.f. waveform (Fig. 1.1.6) and the magnitude of this signal will vary as the resistance of the crystals varies.

R.F. Superimposed on A.F. Waveform

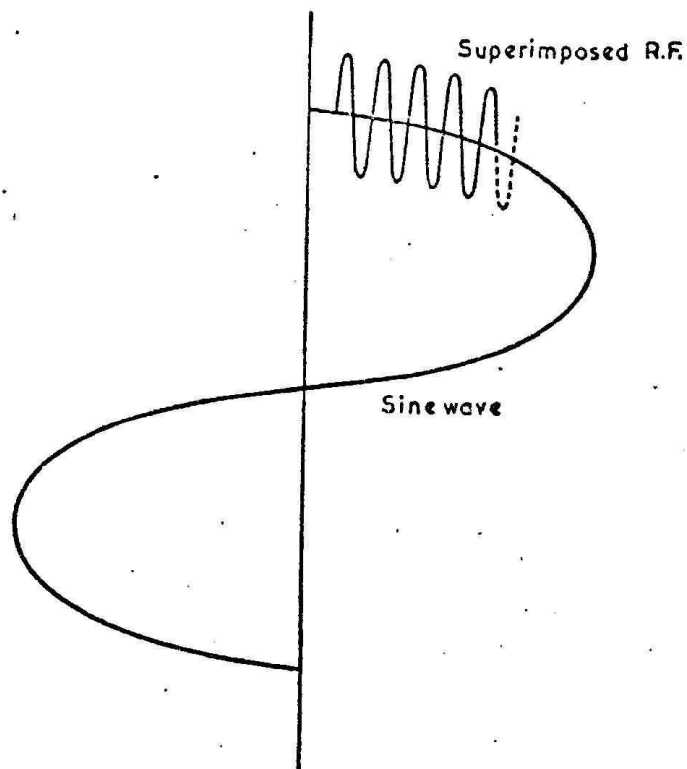

(Fig. 1.1.6)

31. If a suitable oscilloscope is connected across R6 it should be possible to see the r.f. waveform varying in amplitude (Fig. 1.1.7). In other words, the r.f. waveform is amplitude modulated.

Amplitude Modulated R.F.

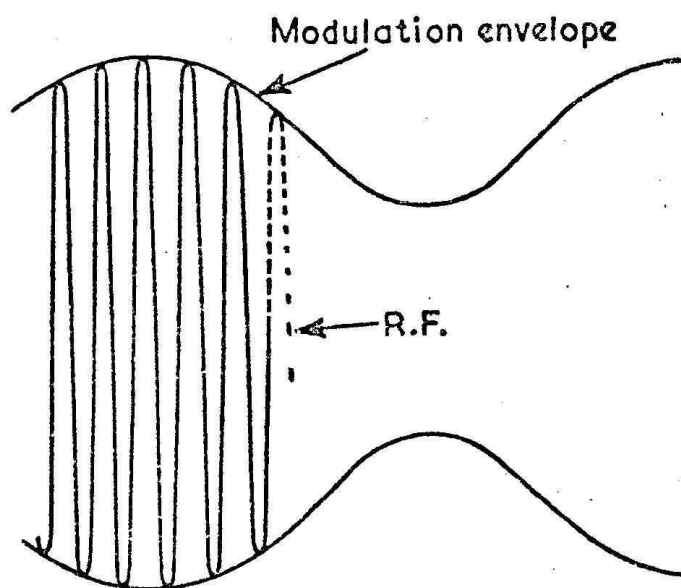

(Fig. 1.1.7)

32. Correct selection of circuit values, d.c. bias for the crystals, magnitude of the 1000 c/s modulation signal and a constant impedance attenuator in place of R6 (in Fig. 1.1.4) is all that is now required to meet the specification.

The Modulation Circuit

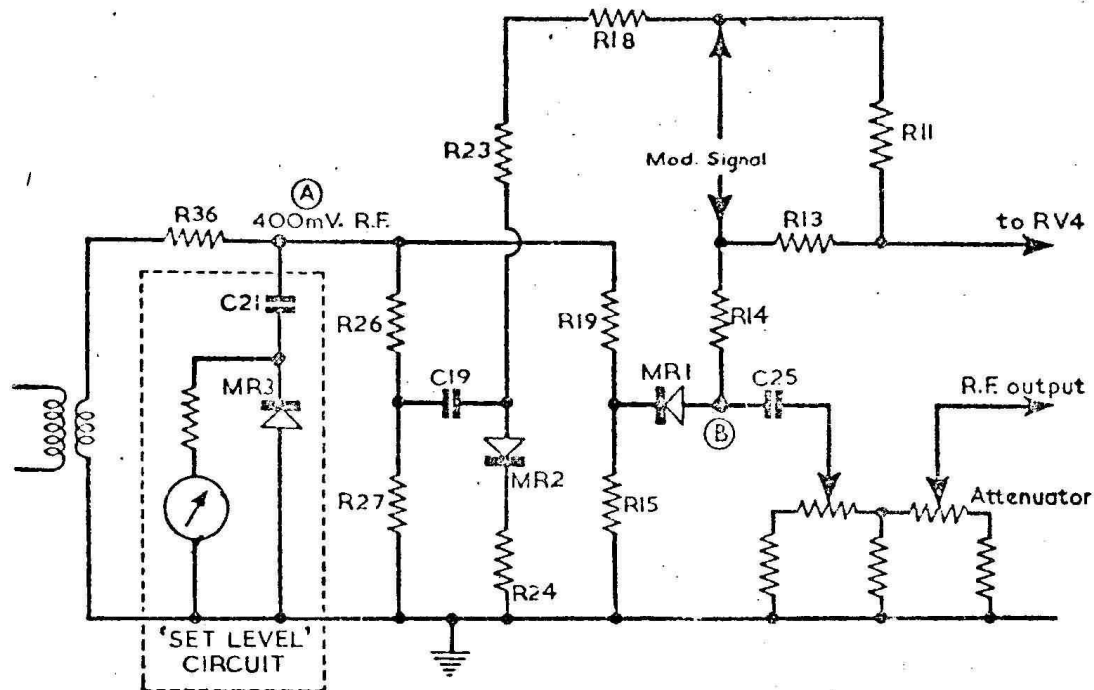

(Fig. 1.1.8)

33. The operation of the whole modulation circuit can be better understood from the more detailed but still simplified circuit (Fig. 1.1.8), which can best be explained by the manner in which it is set up to operate correctly.

34. The r.f. signal is fed to the two potential dividers, R26, R27 and R19, R15, both of which feed into crystal loaded circuits. Each crystal is d.c. biased via R23, R18, R11 and R13, R14, the magnitude of the biasing current being controlled by RV4. Valve V1B supplies the a.f. modulation signal which is fed in anti-phase to the circuit via capacitors C8 and C9. The magnitude of these signals is controlled by RV1 and RV2.

Internal Preset Controls

35. Full setting-up procedure is given later, but can be explained briefly by saying that RV4 is adjusted until a c.w. signal of 25 mV is obtained from the attenuator; it will be noted that the attenuator and R24 present substantially the same loading to the crystal circuits. An oscillograph is then placed between points B (Fig. 1.1.8) and earth, and RV2 adjusted until 30% depth modulation is obtained. The oscillograph is then transferred across points A (Fig. 1.1.8) and earth and RV1 adjusted until a minimum depth of modulation is observed, thus insuring that / whilst the r.f. waveform is being correctly modulated, the load on the r.f. generator remains constant.

The Set Level Meter and Attenuator System

36. The SET LEVEL meter simplified circuit is shown in Fig. 1.1.8. As already explained, the circuit is set in such a manner that when 400 mV r.f. appear between points A and earth, the built-in meter reads on the graduation mark. This ensures that a constant magnitude of signal is fed into the attenuator circuit, quite irrespective of frequency. When the meter has been adjusted by means of the panel control RV3, the output from the r.f. cable, when terminated by 75 ohms, will be as shown on the ATTENUATOR dial settings.

37. The attenuator (Patent Nos. 675, 392 and 699, 684) itself is of interest, for it employs virtually non-inductive resistors housed within a silver-plated, copper-bronze casting which assists in reducing radiation to a very low level.

The Power Supply

(Fig 2.2.11)

38. This is a conventional full-wave rectifier system fed by transformer T1. The primary of the transformer is connected to the supply by r.f. filters which prevent unwanted signals getting either into or out of the generator by the mains lead. A conventional pi-filter network feeds smoothed h.t. to several circuits and, in addition, a neon stabiliser regulates the supply to the r.f. oscillator and the d.c. bias to the modulator circuits. A negative bias line is provided by MR5, C34, R48 and R49 to be fed to 6625-99-972-6001 MODULATOR UNIT SIGNAL GENERATOR. R49 is adjusted in calibration (A.I.C.) to give a 10 mA bias current. This is automatically connected when the MODULATOR UNIT is plugged into CT378A. The bias is picked up from an internal contact accessible via the hole to the right of the R.F. OUTPUT plug. The external pulse is fed into the MODULATOR UNIT via the B.N.C. socket on the side.

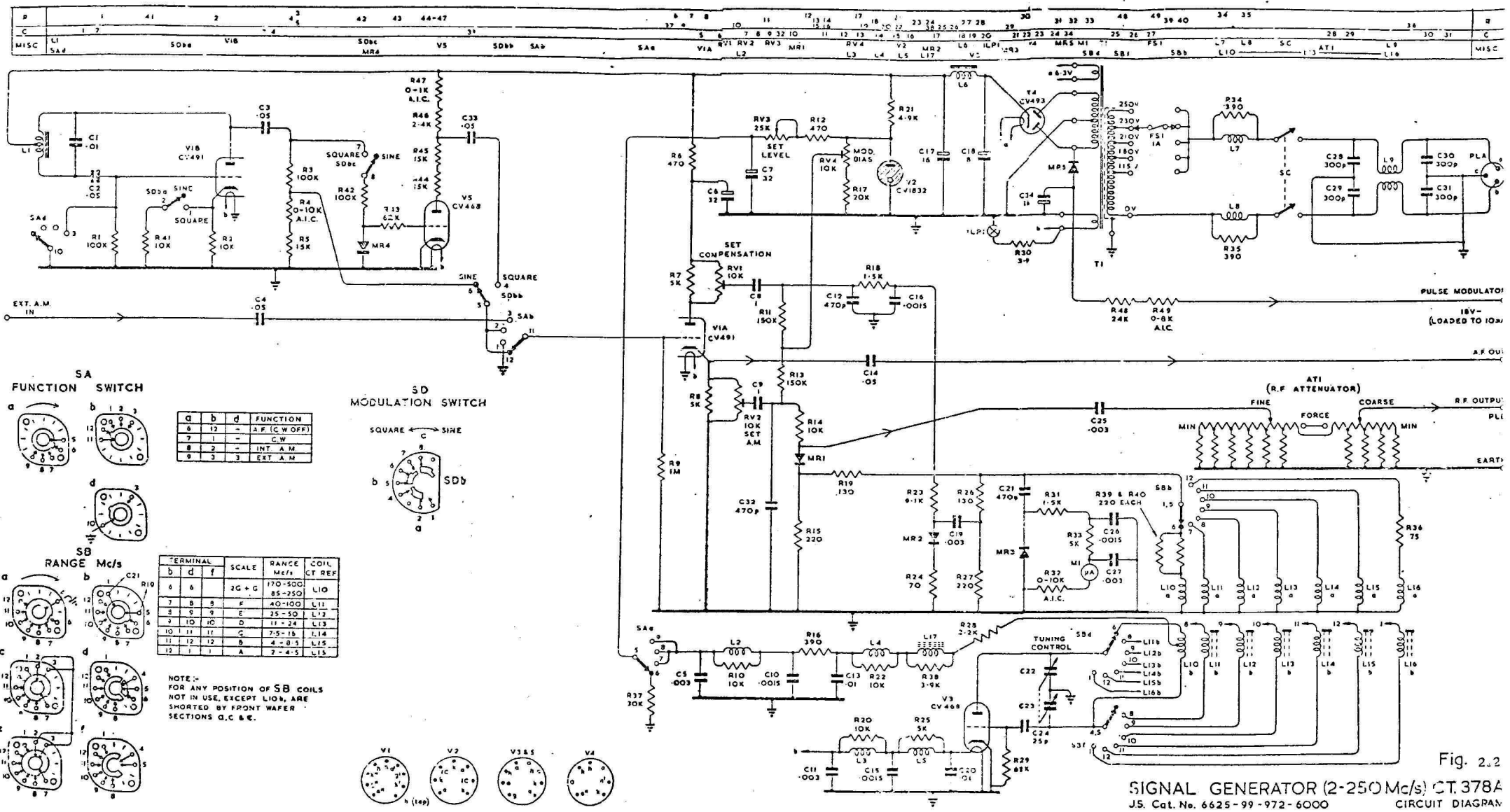

Fig. 2.2

SIGNAL GENERATOR (2-250 Mc/s) CT. 378A
 JS. Cat. No. 6625-99-972-6000
 CIRCUIT DIAGRAM

Before assembling (Det.1) paint all cut edges with Bakelite Varnish (Det. 33)

Stick with Bostick (Det. 35) pieces of Bakelite (Det.36) to inside of top casting to insulate these connections. Cut Bakelite on assembly.

Before assembling (Det's. 7-11) dip in Silicon Resin (Det. 32) and allow to dry.

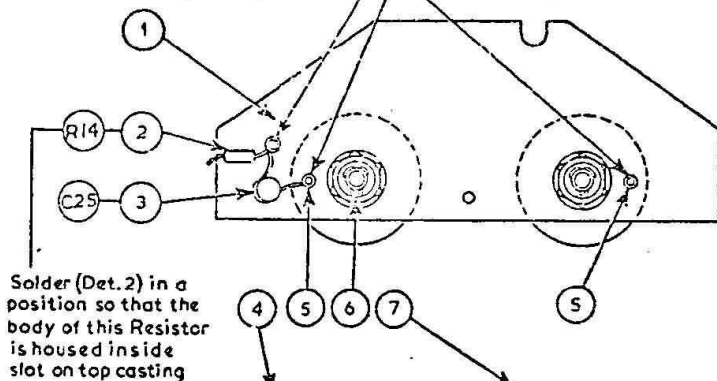

Solder (Det.2) in a position so that the body of this Resistor is housed inside slot on top casting

Section A-A

Fit as req'd. Approx. 3 on each spindle

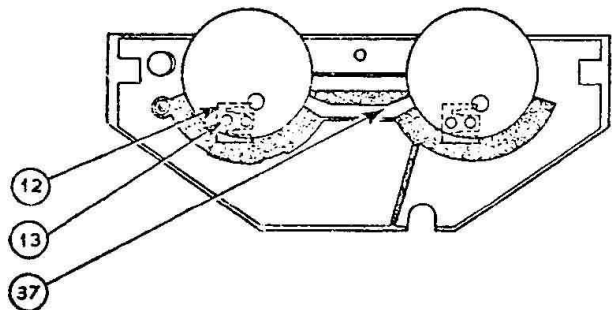

Rivet over this side.

Section B-B

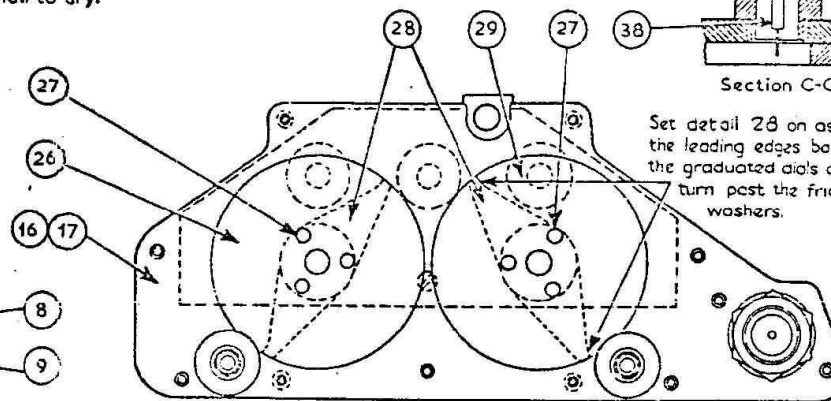

Set detail 28 on assy so that the leading edges bare hard on the graduated dials and do not turn past the friction drive washers.

Section C-C

Section F-F

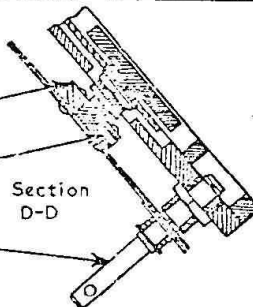

Section D-D

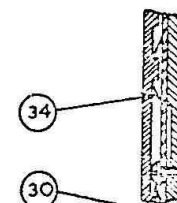

Section E-E

Ensure that radiused edge of Friction Disc Washers (Det. 24) are assembled so that they drive Friction Discs (Dets. 26-29) in this manner.

	Item No.	DESCRIPTION
	1 1	Attenuator
	1 2	Resistor
	1 3	Condenser
	1 4	Pillar Tag
	2 5	Eyelet
	2 6	Split Pin
	2 7	Contact Spindle
	2 8	Bush
	2 9	Special Washer
	2 10	Special Nut
as req'd.	11	Washer
	2 12	Contact
	4 13	Rivet
	1 14	Socket Pillar
	1 15	Co-axial Plug
	1 16	Attenuator Base
	1 17	Attenuator Top
	2 18	Bush
	2 19	Socket Grub Screw
	2 20	Spindle
	6 21	Circlip
	4 22	Washer
	2 23	Spring
	4 24	Friction Washer
	2 25	Threaded Bush
	1 26	Friction Disc
	6 27	Rivet
	2 28	Dial Stop
	1 29	Friction Disc
	1 30	Special Screw
	4 31	Cheese head Screw
as req'd.	32	Silicone Resin
as req'd.	33	Bakelite varnish*
	3 34	Thrust Washer
as req'd.	35	Bostick
as req'd.	36	Bakelite insulation
	37	Metal Segment
	38	Resistor