



AEROVOX

Model 76

**Capacity and Resistance
BRIDGE**

a product of

AEROVOX CORPORATION
NEW BEDFORD, MASSACHUSETTS

AEROVOX MODEL 76

Capacity and Resistance Bridge

General Description

The Aerovox Capacitance-Resistance Bridge Model 76 is a simple-to-operate instrument designed for the accurate measurement of capacitors ranging in value from 100 MMFD to 200 MFD and resistors ranging from 10 ohms to 20 megohms. Provisions are also included for the measurement of the power factor of capacitors as well as a qualitative test for leakage in all types of capacitors.

The instrument operates from a 115v 50-60 cycle power line. To prepare it for use plug the line cord into a power outlet and operate the "Voltage Control" knob clockwise until switch clicks on. Allow sufficient time for the eye tube to light up.

Resistance Measurements

Only two controls are required for this measurement. They are the main center dial calibrated from 0-20 and the lower left hand pointer knob labeled "Multiply By." The settings of all other controls are unimportant here since they are switched out of the circuit when measuring resistance. Note that the switch labeled "Multiply By" is divided into two major sections of 6 positions each. The left hand section marked "Res. Ohm" is used for resistance measurement only.

To measure resistance, place the unknown resistor across the terminals marked "Capacitance-Resistance" using the test leads supplied with the instrument.

Select the proper range on the "Multiply By" knob and carefully adjust the main dial until the indicator eye is at maximum opening. The value of the unknown resistor can now be determined by simply multiplying the main dial reading by the range setting of the "Multiply By" control. For example, if the main dial rests at 10.0 and the "Multiply By" control is set to 1000 then $R_x = 10 \times 1000 = 10,000$ ohms.

Should it be necessary to find the value of a resistor of less than 10 ohms it can be done with fair success by placing it in series with another resistor of between 10 and 190 ohms. Short out the low value resistor and measure the value of the other on the bridge. Record this reading. Remove the short circuit and measure the series combination. The difference between the two readings becomes the value of the unknown resistor.

Since this bridge utilizes a 60 cycle alternating current source it is sensitive to reactance and should not be used to measure the D. C. resistance of choke coils, audio transformers, etc.

In measuring resistors in the higher ranges it is advisable to ground the case of the instrument in order to minimize the effect of stray fields in the vicinity of the equipment. It is also desirable to keep input capacitance low by maintaining short connecting leads kept well apart since excessive capacitance across the input is capable of introducing errors into the higher resistance readings.

Capacitance Measurement

A total of three controls are involved in the measurement of capacitance. The "Multiply By" switch, the main calibrated dial, and the "% Power Factor" dial. Only the right hand section of the "Multiply By" switch marked "CAP. MFD.", is used for measuring capacitance. This section consists of six positions clearly marked for six ranges of capacitance.

The measurement of capacitance is performed similarly to that of resistance except that a power factor reading is introduced.

To measure capacitance, place the unknown across the terminals marked "Capacitance-Resistance", set the "Multiply By" knob to the desired capacitance range, set the "% Power Factor" dial to zero. Now slowly rotate the main calibrated dial and carefully adjust it for maximum eye opening. Now go to the "% Power Factor" knob and adjust it for further opening and sharpness of the eye. Repeat the last two adjustments until no further improvement can be noticed. The capacitance value of the unknown can now be determined by taking the product of the main dial reading and the setting of the "Multiply By" dial. For example, if the main dial rests at 5.0 and the "Multiply By" control is set to .01 then $C_x = 5.0 \times .01 = .05$ MFD.

The percent power factor of the unknown capacitor is made available by reading the setting of the "% Power Factor" dial which is directly calibrated.

Capacitances lower than 100 MMFD may be determined by placing the small unknown in parallel with a capacitor of known value between 100 MMFD and 1000 MMFD. To find the value of the

small unknown, subtract the reading of the known capacitor from the reading of the two connected in parallel.

In measuring capacitors in the lower ranges, it is advisable to ground the case of the instrument. Also keep test leads short and well apart since any added capacitance across the input will affect the accuracy of the bridge reading.

Leakage Test

All panel components to the right of the main dial are concerned with the measurement of leakage of capacitors. They consist of a pair of polarized terminals, neon indicator lamp, knife switch for selecting a test circuit for electrolytic capacitors or a test circuit for all mica and paper capacitors, and a voltage control for varying the D. C. Voltage applied to the capacitor under test.

The voltages marked on the panel are those which appear across capacitors under test and are not open circuit voltages.

To test an electrolytic capacitor for leakage, set the "Voltage Control" knob to zero, throw the knife switch to "Elec." and connect the capacitor under test across the "Leakage Output" terminals by means of the test leads supplied with the instrument. Be careful to observe correct polarity. Slowly advance the "Voltage Control" while observing the neon lamp. A shorted capacitor will show itself immediately by the lighting of the neon lamp with the "Voltage Control" set at zero. For a good electrolytic it should be possible to advance the "Voltage Control" to read the full rated D. C. working voltage of the capacitor under test before the neon lamp remains in a glowing condition.

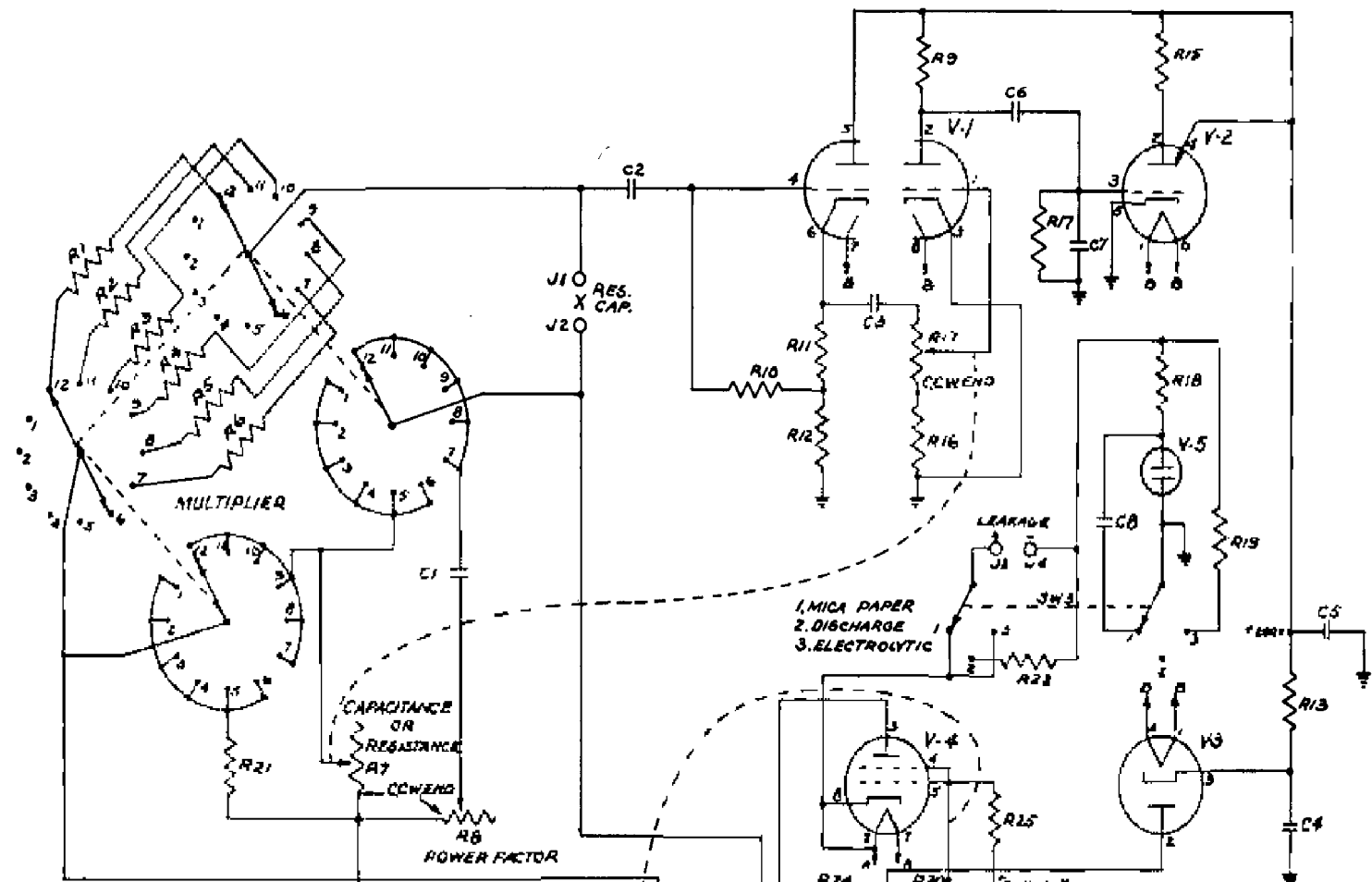

SWITCHING POSITIONS

CAPACITY	RESISTANCE
12 10-200 MFD	6 10-200 W
11 1-20 MFD	5 100-2000 W
10 1-2 MFD	4 1000-20000 W
9 10000-200000 MFD	3 10000-200000 W
8 1000-20000 MFD	2 100000-2 MEG
7 100-2000 MFD	1 1 MEG-20 MEG

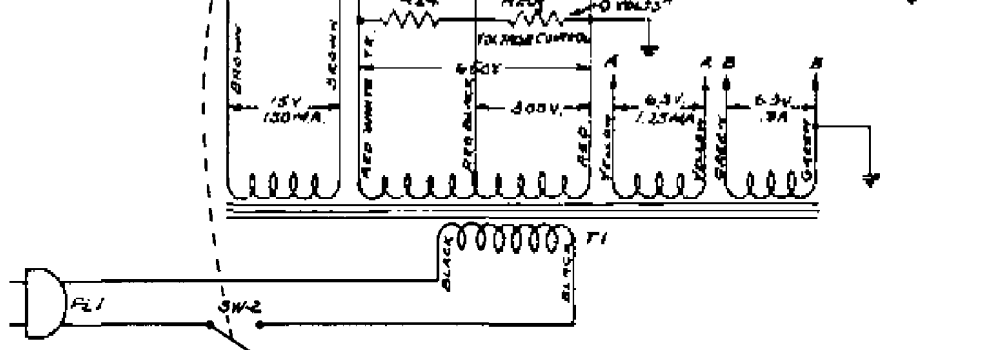

Should the neon lamp maintain a constant glow before the "voltage control" is advanced to this value the capacitor has excessive leakage and should be allowed to form. If the neon lamp does not go out in about 10 minutes the capacitor is defective and should be discarded. In some cases, if the voltage control is advanced too rapidly, the neon lamp will glow momentarily and then quickly extinguish itself before the capacitor's rated working voltage is reached. This is a transient condition caused by a rapid change in charging current thru the capacitor and should not be interpreted as leakage.

In cases where the capacitor has been idle on the shelf for some time, it will be necessary to form it under rated working voltage for a short period before deciding on its leakage merit. A poorly formed capacitor will cause the neon lamp to glow at under-voltage, but as it forms, the lamp will gradually extinguish. This condition should not be confused with leakage.

To test mica or paper capacitors operate the knife switch to the "M-P" position, connect the component under test to the "Leakage output" terminals and set the "Voltage Control" knob to the "All M-P" mark on the dial. Leave the control set to this mark for the testing of mica and paper capacitors.

Should the neon indicator maintain a constant glow, the capacitor under test is short circuited and should be rejected.

Leaky mica and paper capacitors cause the neon indicator circuit to work as a relaxation oscillator, such that the neon indicator will flash when a leaky component is tested. The rate of flash of the neon indicator is directly proportional to the leakage across the capacitor un-

der test. For example, a leakage resistance of 100 megohms will cause the neon indicator to flash at the rate of 20 to 40 times per minute. Higher leakage will increase the rate of flash and conversely, lower leakage will decrease the rate of flash. The neon lamp will not flash at all for capacitors having very small or zero leakage.

Bridge Circuit

The Wheatstone Bridge is a precise method for the measurement of resistance. Such a bridge is simple to operate and requires but one adjustment to attain zero current thru the galvanometer.

The same is true when the bridge is operated on A. C. and all four arms are pure resistances. A bridge of this form is utilized in the Aerovox model 76 instrument to measure resistance.

When the controls are set for resistance measurement, the bridge is connect

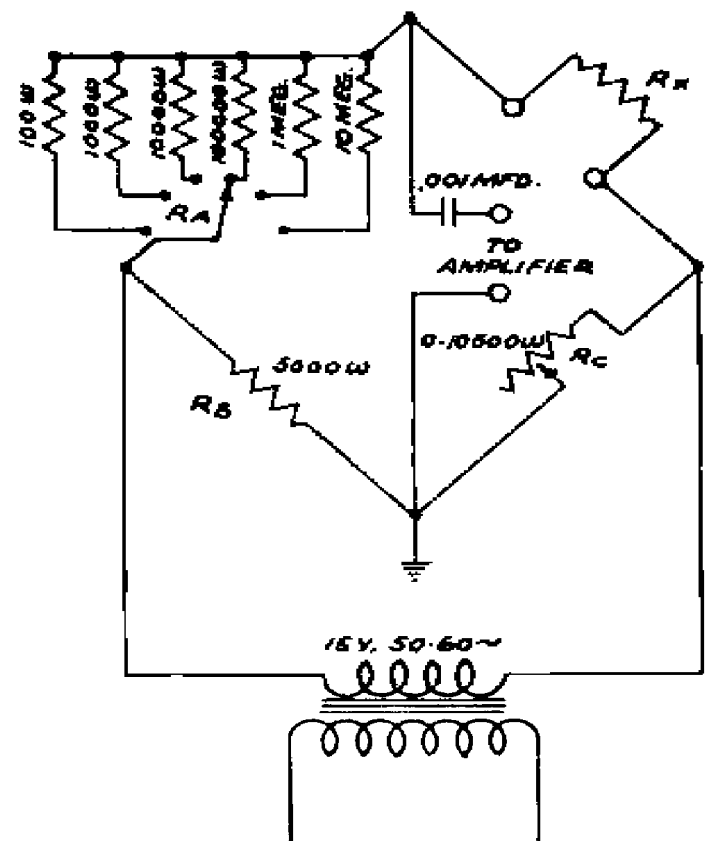

FIGURE -1

ed as in Figure 1. This is a simple resistance bridge operated on A. C. The equation for R_x is

$$R_x = \frac{R_a}{R_b} R_c$$

R_A is chosen by the multiplier switch which is marked with the appropriate multiplication factors. R_c is the variable resistor which has been adjusted so as to be variable from 0 to 10,500 ohms. Its setting is controlled by the main calibrated dial on the instrument panel. The bridge source voltage is provided by a special winding on the power transformer and delivers 15 volts at the power line frequency.

The output of the bridge is applied to the input of a 6SL7 Twin Triode High Gain Amplifier, the output of which is applied to the grid of a 6E5 indicator tube which is very sensitive to the balance point of the bridge, indicated by maximum opening of the eye.

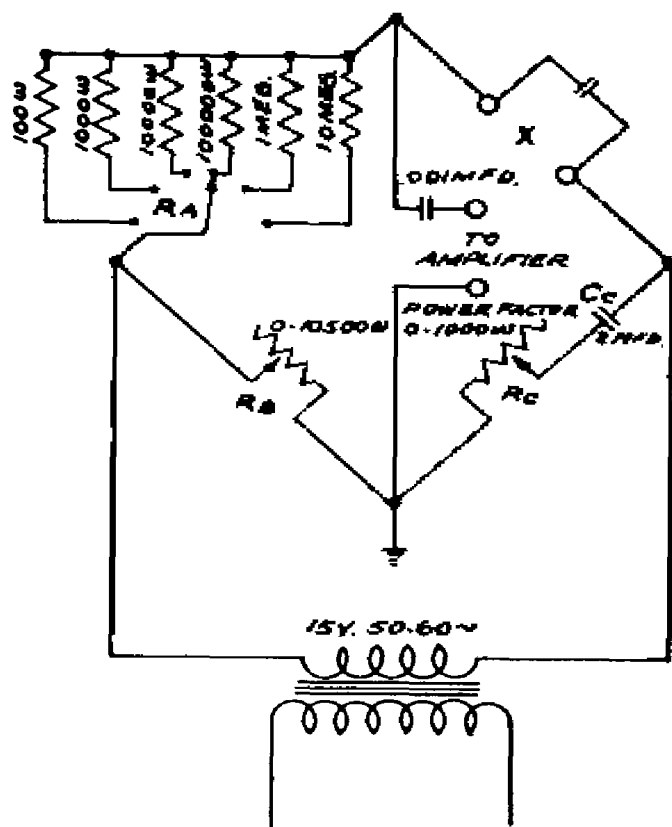

FIGURE-2

Two balances are required in the measurement of capacitance. First, the bridge indicator should connect two points of equal potential and satisfy the equation

$$\frac{R_x}{R_a} = \frac{R_c}{R_b}$$

second, the alternating potentials at the two points must be in phase with each other to satisfy the equation

$$\frac{C_x}{C_c} = \frac{R_b}{R_a}$$

The first equation indicates a balance of resistance components, the second a balance of reactance components. In the bridge circuit of Figure 2 the value of C_x is

$$C_x = \frac{R_b}{R_a} C_c$$

and

$$\text{POWER FACTOR} = \frac{100 R_c}{\sqrt{R_c^2 + \left(\frac{1}{\omega C_c}\right)^2}} \text{ PERCENT}$$

From this it is apparent that the balance adjustments for capacity and power factor are not interlocking and that R_c can be directly calibrated in percent power factor, since the value of C_c is a constant.

Procedure for the measurement of capacitance is explained under "Capacitance Measurement."

Leakage Circuit

A D. C. polarizing potential continuously variable from 0-600 volts is provided for the leakage test. The "Voltage Control" R20 is a 1 megohm potentiometer for adjusting the control voltage on the grid of the 6Y6G, a grid controlled type of rectifier tube well suited for the purpose.

The voltages marked on the panel are those which appear across capacitors under test and are not open circuit voltages.

A two-circuit 3-position knife switch SW3 chooses the proper circuit for indicating leakage of electrolytic capacitors in one position and that of all mica and paper capacitors in another. The neutral position of the switch serves to safely discharge the capacitor under test thru resistor R22.

A neon filled type 991 tube serves as an indicator for the leakage tests. The characteristics of the 991 are such that it will glow when the voltage across it rises above a certain point. R18 serves to limit the current thru the 991 tube to a safe value when it is conducting.

With an electrolytic capacitor connected to the leakage test terminals and SW3 thrown to the "Elec" Position the existing circuit consists of the polarizing voltage in series with the capacitor under test and resistor R19. The current flow thru this circuit is then dependent on the magnitude of the polarizing potential and the leakage merit of the electrolytic under test. When the current flow becomes large enough, the voltage drop across R19 is sufficient to cause the 991 tube to conduct. Proper choice of R19 and the calibration of the "Voltage Control" dial furnish the necessary parameters for determining the leakage merit of any electrolytic capacitor.

With the knife switch thrown to the "All M-P" position, R19 is replaced by a capacitor, C8. If a leaky mica or paper capacitor is connected across the leakage test terminals, the circuit acts as a relaxation oscillator, as follows:— C8 will tend to charge to the polarizing

potential thru the leakage resistance of the test capacitor. When the charge of C8 reaches the voltage sufficient to start the 991 tube conducting, C8 will discharge thru the now conducting 991. The 991 will extinguish when C8 discharges to a potential insufficient to maintain conduction in the 991 tube. C8 will start to charge up again and the process will repeat itself at a constant rate. Since C8 is constant, the leakage resistance in the capacitor under test determines the rate of flash of the indicator tube. A leakage resistance of 100 megohms will cause the tube to flash at a rate of from 20 to 40 times per minute. Higher leakage resistance causes a lower flash rate, while a lower leakage resistance will increase the flash rate.

Mechanical Description

The panel for this instrument has been carefully worked out to provide simplicity of operation together with proper technical arrangement. Brief instructions for each of the controls are etched directly on the panel, so that once general operation of the bridge is understood, no further reference need be made to instructions. The binding posts are insulated from the panel with Type XXX Bakelite Spacers. The red binding post in the leakage circuit indicates the positive connection to the capacitor under test while the red binding post, in the "RES-CAP" Circuit, indicates the terminal highest in potential above ground. The panel is of 1/16 inch thick aluminum sheet with an attractive black anodized finish of lasting durability.

The cabinet is constructed from a single piece of .048 sheet steel bent to shape and welded at the seams. The cabinet finish is black crackle. Four rub-

ber feet are provided on the bottom of the cabinet and the line cord is brought out thru a rubber grommet at the rear.

The resistors for the bridge are individually selected for close tolerance so that the overall accuracy is exceedingly good.

To remove chassis from case, remove the mounting screw from the rear of the case and all mounting screws from the outer edges of the front panel.

Aerovox Personal Registration

With each Aerovox Model 76 Capacity-Resistance Bridge a double card is

provided which contains the warranty shown on page 11. The postcard half of the card should be filled out, giving the serial number stamped into the face of the instrument, the name and address of the initial purchaser, name of the jobber from whom the instrument was purchased, and then mailed to Aerovox Corporation, New Bedford, Mass.

This validates the Warranty and serves as identification of the owner of that particular Bridge.



N O T E S

AEROVOX

CAPACITY AND RESISTANCE BRIDGE

Model 76

PARTS LIST

<i>Symbol</i>	<i>Part No.</i>	<i>DESCRIPTION</i>	<i>List Price Each</i>
R1	CS127	100 ohms resistor, 1 watt $\pm 2\%$.35
R2	CS126	1,000 ohms resistor, $\frac{1}{2}$ watt $\pm 2\%$.28
R3	CS125	10,000 ohms resistor, $\frac{1}{2}$ watt $\pm 2\%$.28
R4	CS124	100,000 ohms resistor, $\frac{1}{2}$ watt $\pm 2\%$.28
R5	CS123	1 megohm resistor, $\frac{1}{2}$ watt $\pm 2\%$.28
R6	CS122	10 megohm resistor, $\frac{1}{2}$ watt $\pm 2\%$.28
R7, R14	CS103	5 megohm and 10,500 watt potentiometer on same shaft	3.28
R8	CS145	1,000 ohms potentiometer	1.05
R9, R13	CS132	100,000 ohms resistor, $\frac{1}{2}$ watt 20%	.17
R10	CS133	5 megohm resistor, $\frac{1}{2}$ watt 20%	.17
R11	CS134	1,500 ohms resistor, $\frac{1}{2}$ watt 20%	.17
R12	CS135	70,000 ohms resistor, $\frac{1}{2}$ watt 20%	.17
R15, R16, R17	CS138	1 megohm resistor, $\frac{1}{2}$ watt 20%	.17
R18, R22	CS185	30,000 ohms resistor, $\frac{1}{2}$ watt 20%	.17
R19	CS191	5,100 ohms resistor, 2 watts, 5%	.30
R20-SW2	CS101	1 megohm carbon potentiometer with single-pole, single-throw switch	1.50
R21	CS146	5,000 ohms wire-wound resistor $\pm 1\%$	1.00
R24	CS190	330,000 ohms $\frac{1}{2}$ watt resistor 20%	.17
R25	CS182	2 megohm resistor, $\frac{1}{2}$ watt, 20%	.17
C1	CS148	2 mfd. capacitor (1 mfd.-1 mfd.)	.60
C2	CS149	.001 mfd. 400 volt capacitor	.20
C3, C6, C7	CS150	.01 mfd. 400v. capacitor	.20
C4, C5	CS151	4 x 4 mfd. dual capacitor 450v.	1.50
C8	CS183	.1 mfd. 200v. capacitor	.25
V1	CS107	6SL7 Tube	1.90
V2	CS105	6E5 Tube	1.30
V3	CS104	1V Tube	1.20
V4	CS106	6V6G Tube	1.80
V5	CS181	991 Tube	1.70
SW1	CS108	Range Selector Switch	2.35
SW3	CS142	2-pole, 2-position Switch	1.00
T1	CS100	Transformer	5.00
J1, J3	CS116	Jack	.25
J2, J4	CS115	Jack	.25
PL-1	CS110	Line Cord	.75
	CS141	Case	6.00
	CS140-CS112	Knob and Pointer	.90
	127K	Bar Knob	.25