

# ***Signal Generator*** **SG62B** **Instruction Manual**

ADVANCE ELECTRONICS LIMITED  
INSTRUMENT DIVISION  
ROEBUCK ROAD, HAINAULT, ILFORD, ESSEX, ENGLAND  
TELEPHONE: 01-500 1000 TELEGRAMS: ATTENUATE ILFORD

## Advance OS25 Oscilloscope

---

### 1 Introduction

The OS25 is a dual trace oscilloscope. This instrument is the continuation of an already successful range of high quality oscilloscopes and although retaining simplicity of operation and ease of servicing it incorporates many features normally associated with more expensive oscilloscopes.

One of these features is automatic selection of the operating mode most suited to time base speed. This is achieved by changing from beam switching, for the two slowest time base ranges, to alternate sweep for the four upper ranges.

The bandwidth of the vertical amplifier extends from DC to 5 MHz and the time base from 1 sec/cm to  $0.5\mu\text{S}/\text{cm}$ , using switched and fine controls. The triggering facilities of the OS25 are fully comprehensive; both input channels can be triggered internally using either channel input signal, or externally using a suitable source, including the pulses of a composite TV waveform.

In this attractively designed instrument reliability has been achieved by the partial use of solid state circuitry and this has also contributed to its lightweight, yet rugged, construction.



## Advance OS25 Oscilloscope

---

### 2 Specification

#### VERTICAL AMPLIFIERS

Bandwidth: DC to approx. 5 MHz (-3dB)  
Sensitivity: 100mV/cm  
Input Impedance: Nominally 1M $\Omega$ /35pF  
Measuring accuracy: Typically  $\pm 5\%$

#### INPUT ATTENUATOR

Nine-position switched attenuator giving sensitivities of 100mV/cm to 50V/cm in a 1, 2, 5 sequence.  
For AC input a 400V DC blocking capacitor is provided.

#### TIME BASE

Calibrated speeds of 100, 10, 1mS/cm and 100, 10, 1 $\mu$ S/cm  
Measuring accuracy:  $\pm 5\%$  typically  
Continuous adjustment from 1sec/cm to 0.5 $\mu$ S/cm using X GAIN and VARIABLE TIME controls.

#### X EXPANSION

Up to two screen diameters. Any part of expanded trace can be centred on screen.

#### TIME BASE OUTPUT

Available at a rear panel socket (X OUT) as a negative-going saw-tooth waveform of approximately 4.5V.

#### HORIZONTAL AMPLIFIER (X IN)

Bandwidth: 5Hz to 100kHz approx  
Sensitivity: 0.25V/cm to 0.5V/cm approx

#### TRIGGERING

Internal or external  
Auto: 50Hz to 1 MHz. positive or negative  
Trigger level selection: Up to 3MHz, positive or negative.  
Trigger sensitivity: Internal, typically 2mm vertical deflection. External, typically 1V.  
TV sync: A built-in TV sync. integrator permits triggering from frame pulses of a composite TV waveform.

#### Z MODULATION

An input terminal at the rear of the instrument is AC coupled to the CRT. Negative going pulses brighten the trace. Sensitivity 50V pk.

#### CATHODE RAY TUBE

5in. helical PDA type operated at 3kV overall.  
Display area: 10cm horizontal, 8cm vertical.

#### POWER REQUIREMENTS

100 to 125V, 200 to 250V, 50 to 60Hz, 80VA.  
Voltage taps at 110, 200, 220 and 240V. The above specification applies at the nominal tap of 240V.

#### DIMENSIONS

11in. high, 8  $\frac{3}{16}$  in. wide, 15  $\frac{5}{8}$  in. deep. (28 x 21.3 x 40 cm).

#### WEIGHT

18  $\frac{3}{4}$  lb (8.5 kg).

## 4 Circuit Description

### 4.1 GENERAL

A functional diagram of the oscilloscope is shown in Fig. 1. The following circuit description considers the functions of these blocks and builds up

an overall picture of the circuit operation, with the aid of circuit diagrams Fig. 3 and 4.

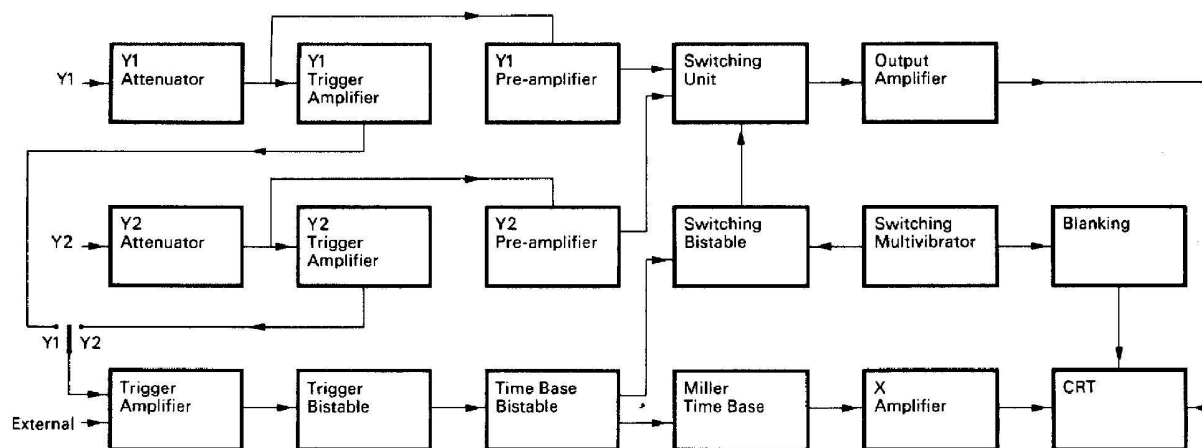

Fig. 1. Functional Diagram

### 4.2 INPUT ATTENUATORS

Each of the identical attenuators for channel 1 and channel 2 (Y1 and Y2) consists of a nine position switch selecting cascade pairs of frequency compensated networks which provide nine calibrated input sensitivities in 1, 2, 5 steps.

### 4.3 INPUT PROTECTION

For AC input conditions a 400V blocking capacitor is provided. For DC input conditions the input impedance appears as  $1M\Omega$  shunted by 35pF, and the input is limited by the dissipation in the associated components. The maximum input level of 400V pk. pk. applies up to approximately 20kHz. Above 20kHz consideration must be given to the level of current that may flow in the equivalent input capacitor.

### 4.4 VERTICAL PRE-AMPLIFIERS

Each input channel is identical, therefore, a description of channel 1 also applies to channel 2. Two component references are used (one for each channel) and are separated by an oblique stroke. Input signals pass from the input terminals through the attenuators to the grids of the input cathode follower (V101b/V102b). RV101/RV102 are preset to equalise the gains of the two channels. From V101b/V102b signals pass through zener diode-potentiometer shift networks (MR101, RV1/MR102, RV2) to the bases of two emitter followers. Associated with each pre-amplifier is a trigger amplifier (V101a/V102a) the outputs being taken to the trigger selection switch.

### 4.5 SWITCHING UNIT

This consists of a bistable (VT105, VT106) driven by input pulses from a multivibrator (VT107, VT108) and from the time base bistable. The switching bistable drives a four diode gate (MR103, MR105/MR104, MR106) which is in turn fed by inputs from the two pre-amplifiers. The output of the gate is taken to the main Y amplifier. This output consists of either a 75kHz square wave containing the two input signals on alternate half cycles (beam switching), or a variable frequency square wave locked to the time base frequency (alternate sweep). The two lower time base ranges operate on beam switching while the four upper ranges use alternate sweeps. Change over from one mode to the other is automatic with the setting of the time base speed. In the beam switching mode of operation, pulses from the multivibrator are taken to the blanking valve V205b. This valve blanks-off the CRT grid during the transition period.

### 4.6 OUTPUT AMPLIFIER

The output from the switching unit is fed to the base of VT103 which together with VT104, V103a and V104a form a hybrid cascode amplifier. The overall gain of the amplifier (both channels together) is set by RV105 and the h.f. response is set by C139. The output from the anodes of V103a and V104a is applied to the Y plates of the CRT via cathode followers V103b and V104b. RV106 adjusts astigmatism and RV107 adjusts pincushion geometry (see paras. 5.8 and 5.9).



## Advance OS25 Oscilloscope

### 4.7 TIMEBASE TRIGGER

The time base trigger circuit comprises an amplifier V201a, a phase splitter V201b and a cathode coupled bistable circuit V202. The time base can be triggered either internally from a signal derived from either of the vertical trigger amplifiers (V101a, V102a) or externally from a trigger source applied to the EXT. socket. The trigger input is amplified by V201b, phase split by V201a and applied to the bistable circuit (V202) via the polarity switch S5.

The selected signal is applied to the grid of V202b, part of the cathode coupled bistable. This circuit is controlled by S7 (AUTO) and acts as a bistable device locking to positive or negative pulses at a point determined by the setting of RV3A (LEVEL), when the switch is in the manual position, or a free running multivibrator when S7 is in the AUTO position. In this position, in the absence of a trigger signal, the repetition frequency of the circuit is determined by C205, R212 and R213 and is approximately 50Hz.

When operating in this mode the circuit locks readily to positive or negative inputs up to 2 MHz applied to V202b grid. The output of V202a anode is differentiated by R218 and C207 and the positive excursions are removed by MR201.

The negative spikes are applied to the grid of V203b in the time base circuit via MR202. The first negative going spike drives V203b to cut-off and triggers the time base valve V203a. Subsequent negative going signals are ineffective until the time base circuit has completed its action. When S5 is set to TV, the input signals to V202b are integrated and the time base trigger is generated by the frame pulse of the composite TV waveform.

NOTE This position is also useful when it is required to trigger the time base from a low frequency source superimposed with a large level of h.f. noise.

### 4.8 TIMEBASE

The timebase circuit consists of V203, V204b and associated components. The negative signal from MR202 is applied to V203b and drives the grid to cut-off. The anode voltage rises and is applied to V204b grid via S6 (TIME/CM) causing the voltage at V204b anode to fall. This fall is fed back to V203b grid and the action becomes cumulative so that V203b anode rises to h.t. and V204b anode (and hence V203b grid) falls to a relatively low voltage. When V203b cuts-off its cathode potential falls and so does V203a anode. This is also applied to V203a grid via the appropriate timing capacitor between S6a and S6b. This set of circumstances creates a situation where both anode and grid have fallen in potential simultaneously, the valve is almost cut-off therefore,

and current is drawn via R220. The Miller run-down action now starts and V203a grid rises due to the current flowing through the timing resistor (R225, R226, R236) and capacitor. As the grid voltage rises the timing capacitor (C210 - C216) discharges through the valve and the anode voltage falls, thus causing the cathode voltage of V203b to fall also. At some point V203b cathode voltage approaches the voltage on its grid and the valve starts to conduct once more. Cumulative action between V203b and V224b causes V203b to quickly reach its fully conducting state again. The circuit will repeat the foregoing action when the next negative going spike is received.

The action described takes place when RV3b (STABILITY) is adjusted so that the time base just fails to free-run. If RV3b is too far advanced the time base will free-run at a rate determined by the hold-off capacitors on S6c and S6d. These capacitors act as speed-up elements for the trigger action of V203b and V204b and also provide recovery time for the time base.

The required potential for the timing capacitors is derived via RV4 (VARIABLE TIME) which is in series with RV202 (SET SPEED). RV202 is a pre-set potentiometer which is adjusted during manufacture.

When switch S5 is set to TB OFF, EXT. X the cathode circuit of V204b is made open circuit and prevents the valve operating, thus stopping the time base circuit. Also, S5 disconnects the blanking electrode of the CRT from the anode of V203b. The output of the time base is applied to the horizontal (X) amplifier via the frequency compensating network R224, C209, C208 and RV203, C223.

### 4.9 HORIZONTAL (X) AMPLIFIER AND PRE-AMPLIFIER.

V204a and V205a form a long tail pair which makes up the horizontal (X) amplifier. The anode outputs of these valves are applied to the X deflection plates of the CRT. RV204 (set gain) is a preset control which is adjusted during manufacture so that full clockwise rotation of the X GAIN control (RV5a), on the front panel, causes the trace to be expanded by a factor of two. The signal at V204a cathode (a sawtooth waveform) is available at a rear panel socket (X OUT). The output is only linear however, when the trace is not expanded, i. e. X GAIN control is fully anticlockwise. In any other position the output will flatten out top and bottom and will contain a linear portion proportional to that part of the trace occupying the centre 10cm of horizontal deflection.

The grid of V204a is also connected to the X IN socket at the rear of instrument and the applied input is fed to V204a via C2.

When the time base circuit is switched off, any

## Advance OS25 Oscilloscope

---

input applied to the X IN socket is amplified by the X amplifier and applied to the X deflection plates as before.

V205a has the X shift voltage applied to its grid by RV5b.

### 4.10 CATHODE RAY TUBE (CRT)

A helical PDA type tube is used in this instrument and provides a vertical deflection of 8cm and a horizontal deflection of 10cm. Astigmatism is corrected by RV106 (ASTIG) and is preset during manufacture together with RV107 which affects the geometry of the display. Direct coupled bright-up is provided from the time base circuit (V203b) to g2 of the tube. When the time base is switched off, g2 assumes the same potential as a1. Signals applied to the Z MOD socket (at the rear) are fed to the grid of the tube providing brightness modulation.

The brilliance and focus circuits are conventional and control g1 and a2 of the tube respectively.

### 4.11 POWER SUPPLY

MR212, MR213, C238 and C239 form a voltage doubling circuit providing the h. t. for the X and Y deflection circuits. Two +150V regulated h. t. lines are provided by MR214 and MR215. MR211 provides the + 1750V DC for the PDA terminal (a4) and MR210 provides the -1200V DC supply for the cathode. MR205 - MR209 and C230 provide a +15V DC which is regulated to provide +10V (MR204) and +5V (MR203).

The centre tap of the 6.3V AC heater winding is connected to a suitable positive line to avoid voltage stresses between the heaters and cathodes of the valves.



Advance OS25 Oscilloscope

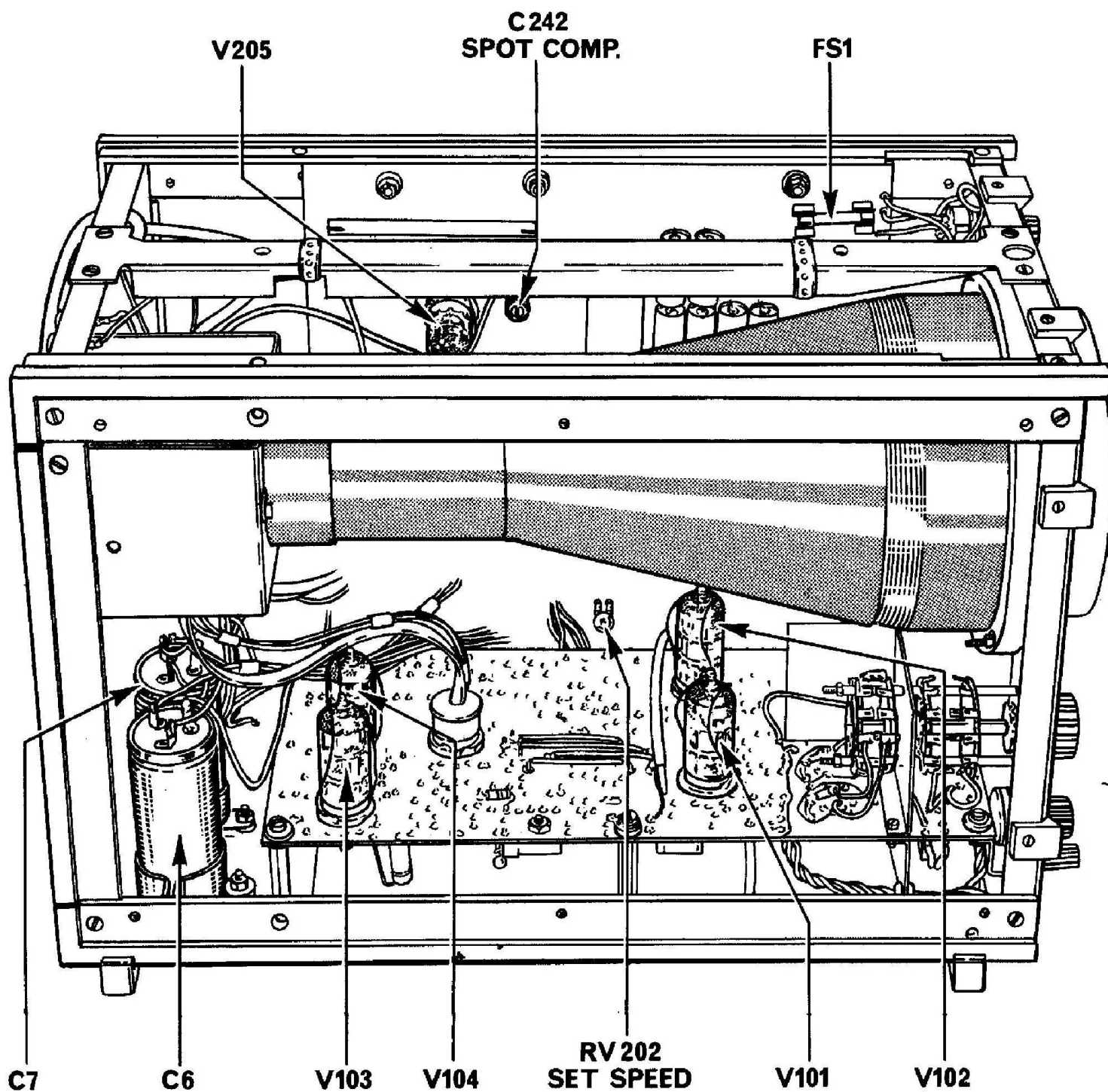
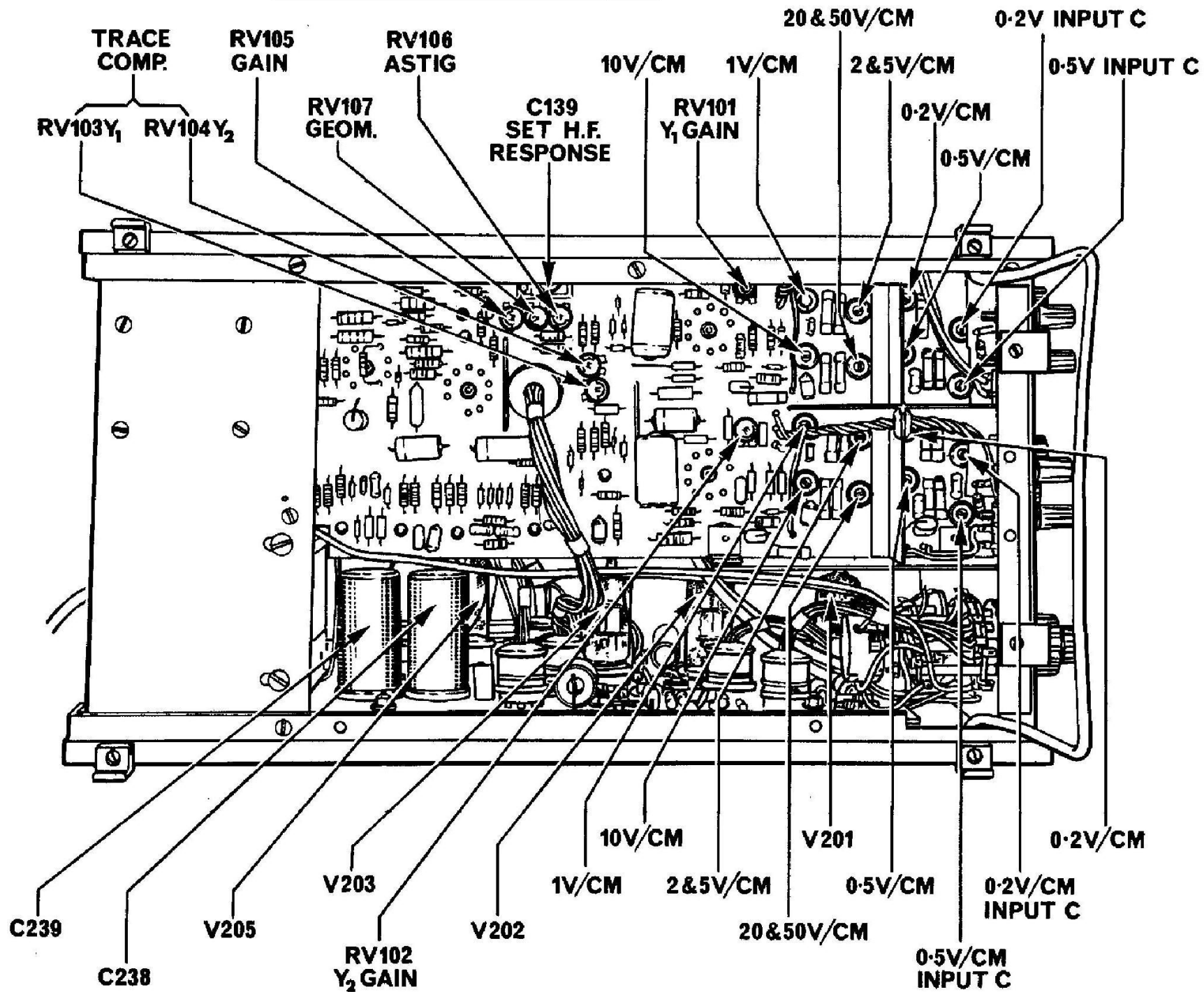

Fig. 2. Component Location Diagram - side view

### Advance OS25 Oscilloscope





# Advance OS25 Oscilloscope

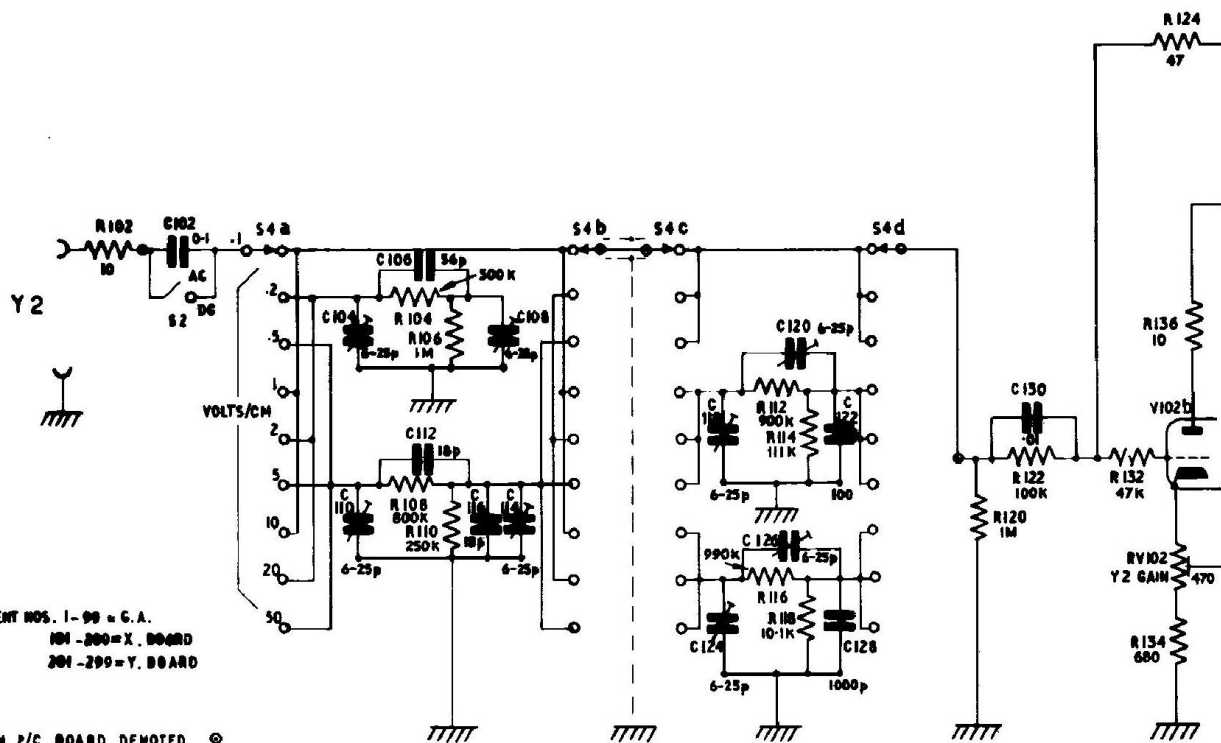
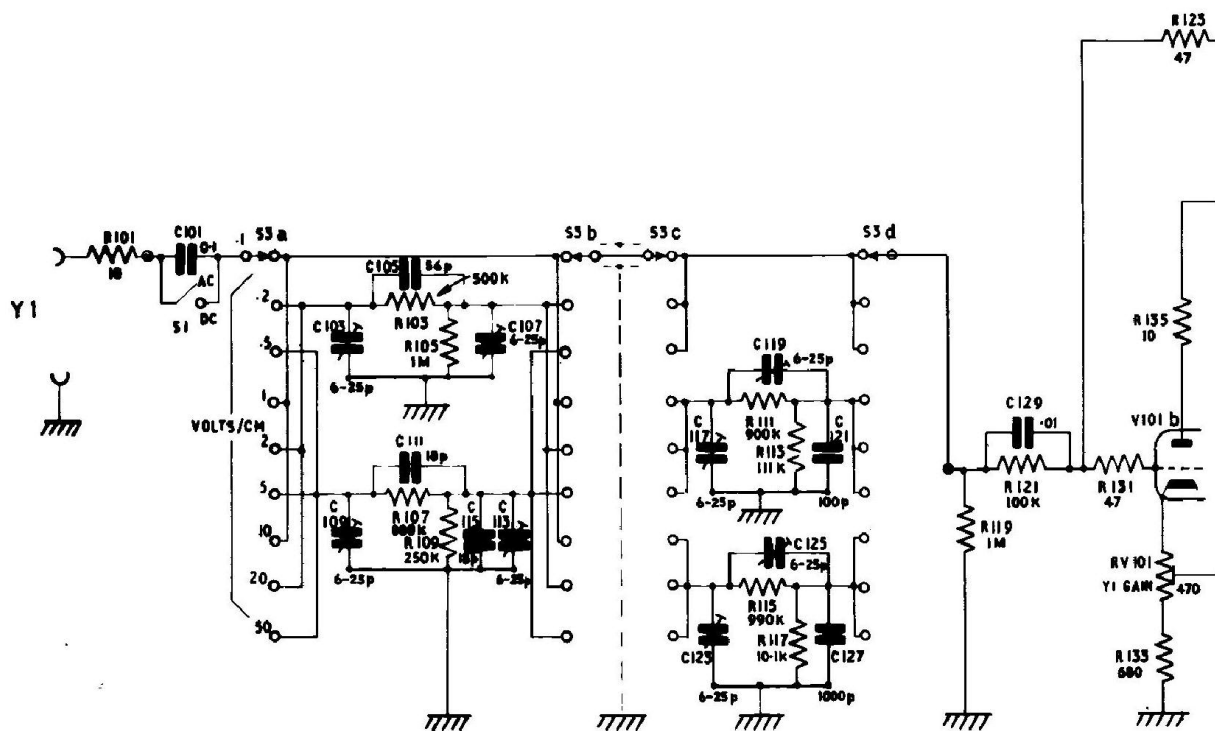

COMPONENT NOS. 1-99 = C.A.  
 101-200 = X. BOARD  
 201-299 = Y. BOARD

LUGS ON P/C BOARD DENOTED ⊙  
 PANEL ACCESS TERMINALS DENOTED ⊃  
 WIRE TERMINATIONS TO PLUGS DENOTED —  
 e.g. IA = PIN 1, PLUG A.

ALL VOLTAGES ARE WITH RESPECT TO EARTH AND MEASURED WITH 20,000 Ω/V METER. VARIATIONS UP TO 10% MAY OCCUR

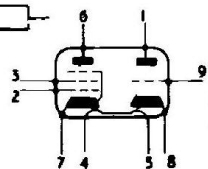

VALVE CONNECTIONS ALL VALVES TYPE ECF 82/6UB.

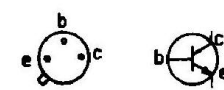
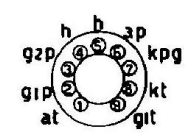

TRANSISTOR CONNECTIONS VIEWED FROM BASE BSX 20

Advance OS25 Oscilloscope

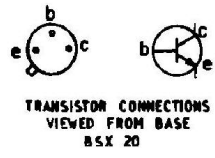
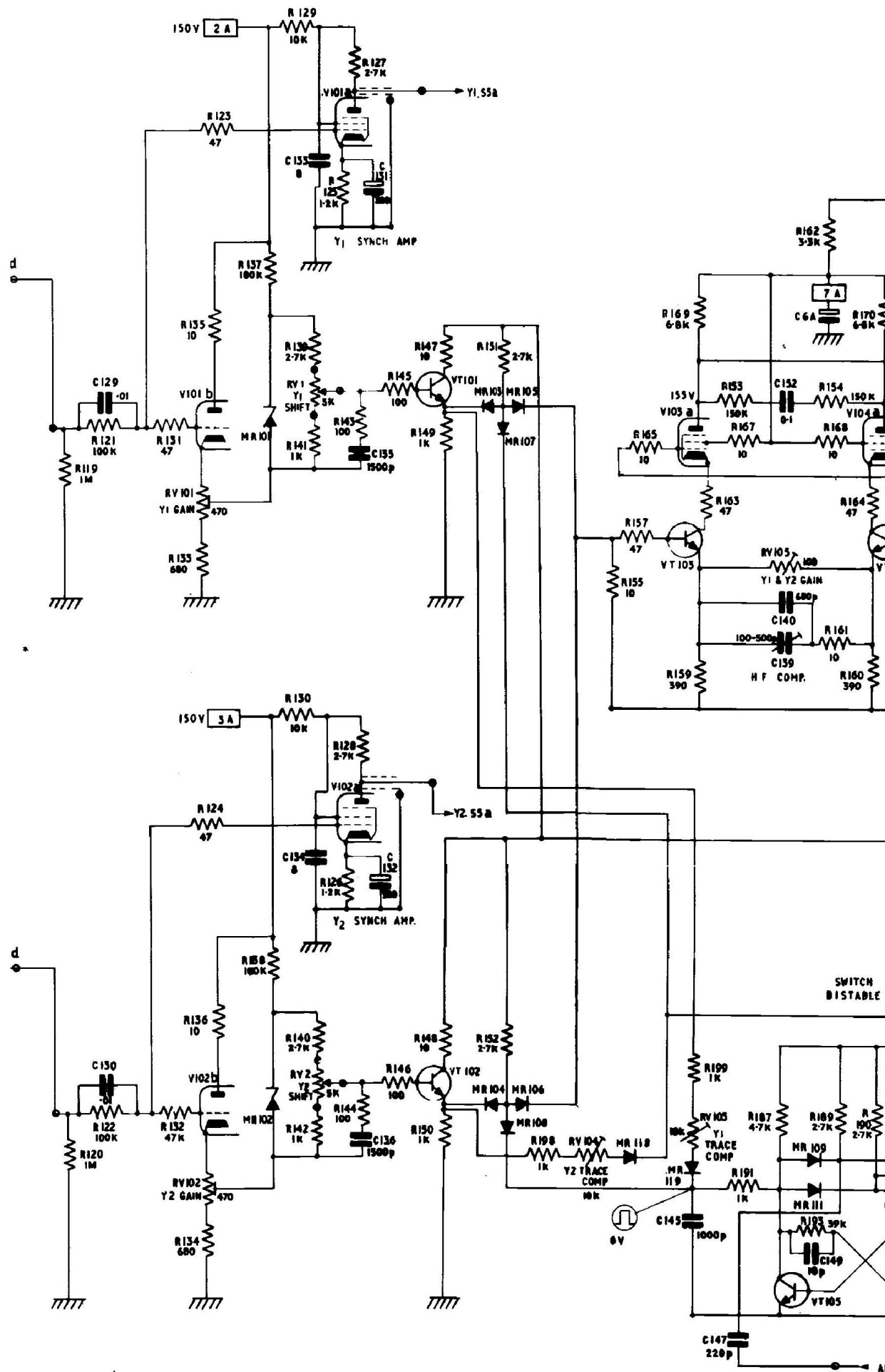





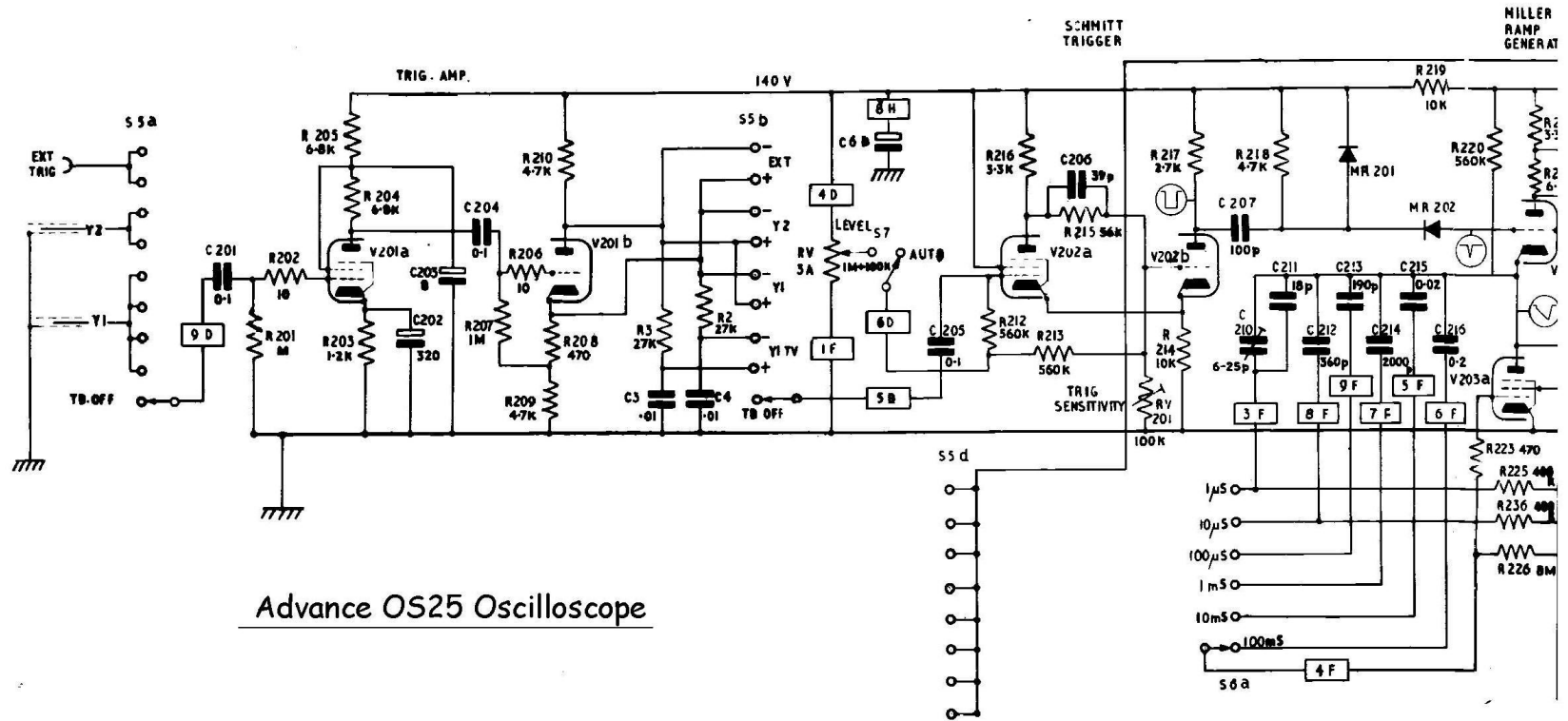

Advance OS25 Oscilloscope

COMPONENT NOS. 1-99 = G. A.  
 101-200 = X. BOARD  
 201-299 = Y. BOARD

ALL VOLTAGES ARE WITH RESPECT TO EARTH  
 AND MEASURED WITH 20,000 OPV METER  
 VARIATIONS UP TO 10% MAY OCCUR

LUGS ON P/C BOARD DENOTED.

PANEL ACCESS TERMINALS DENOTED.

WIRE TERMINATIONS TO PLUGS DENOTED.

e.g. = PIN 1. PLUG A.

S.7. GANGED TO RV3A.  
 S.8. GANGED TO RV6.

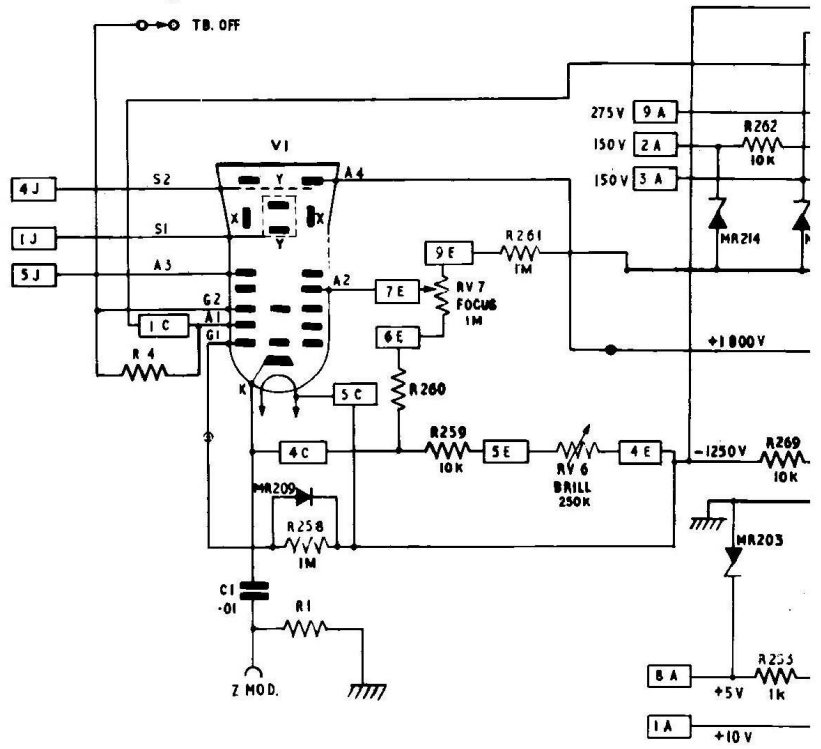

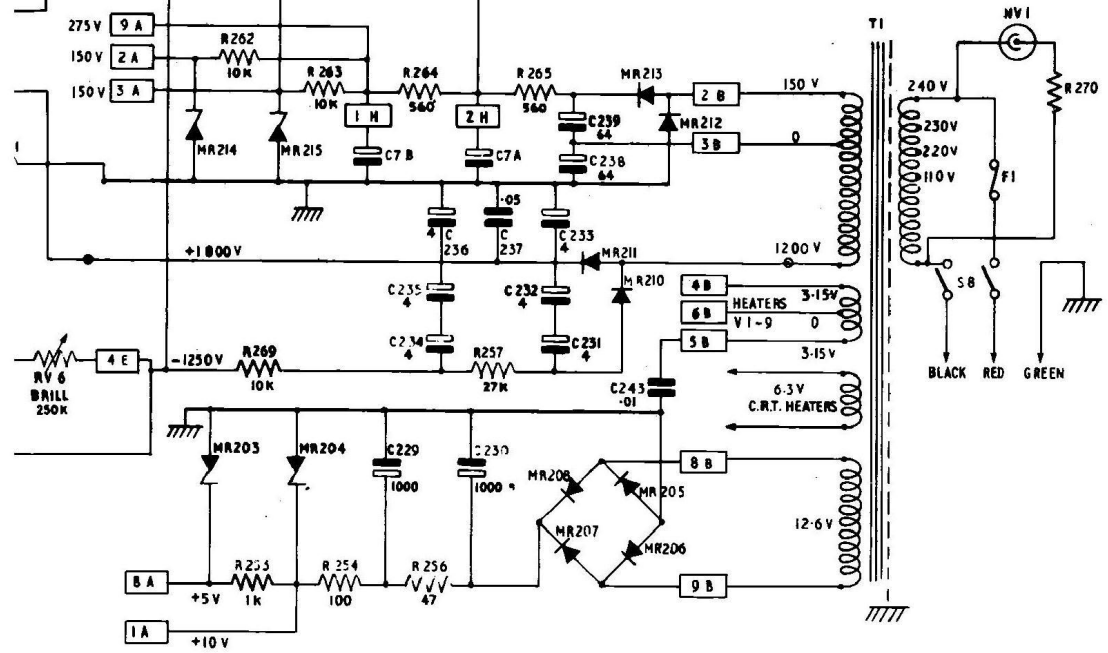
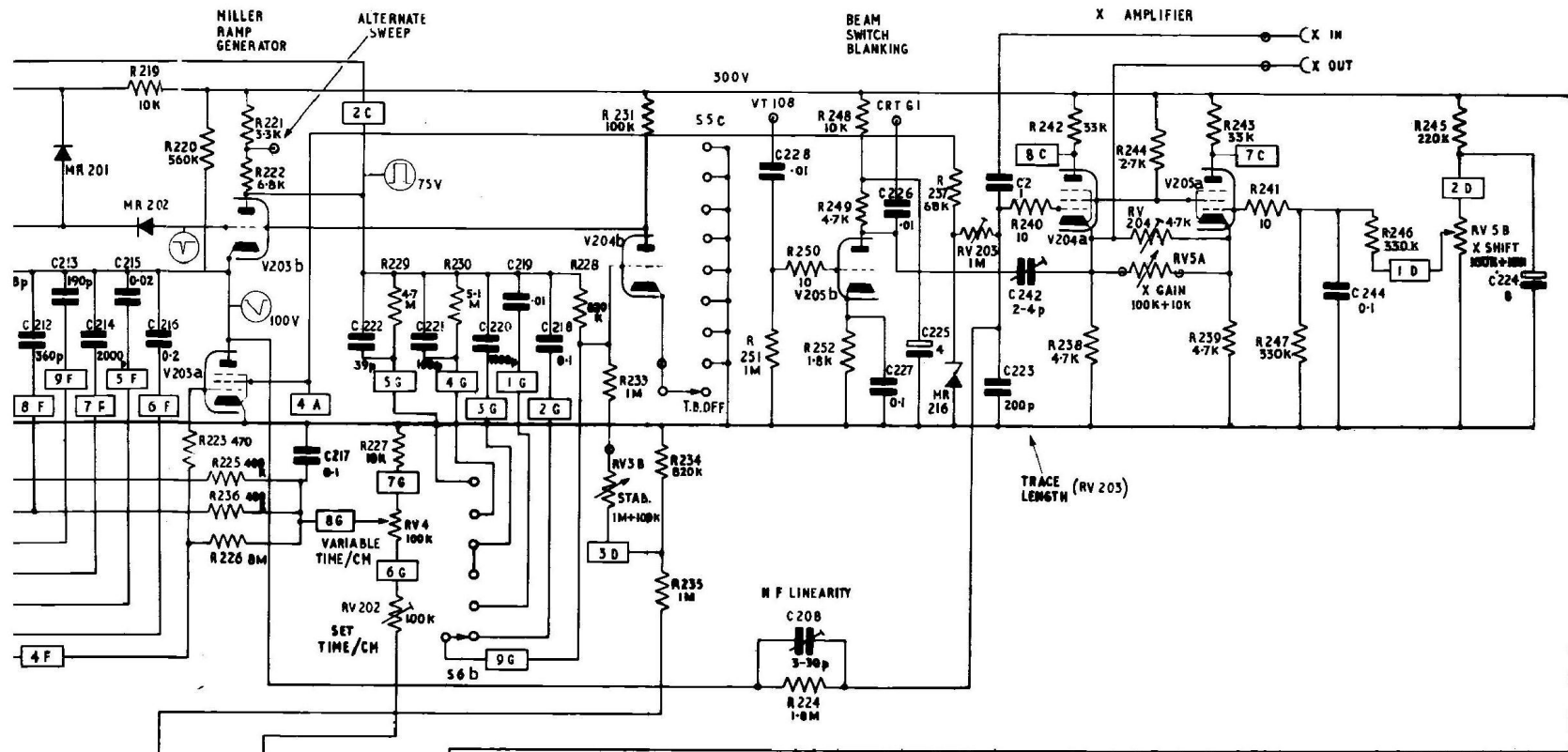

Advance OS25 Oscilloscope