

instruction book

Collins Radio Company | Cedar Rapids, Iowa

75A-4

Amateur Receiver

Collins Authorized Service Agencies

ALABAMA

Beddow Engineering Services
1501 Seventh Street SE
Decatur 35601

ARIZONA

Southwest Electronic Devices
(P.O. Box 3751)
Second Street at Madison
Phoenix 5030

CALIFORNIA

Amrad Electronics
999 Howard Avenue
Burlingame 94101

Amrad Supply, Inc.
3425 Balboa Street
San Francisco 94121

Communication Receiver Service
5016 Maplewood
Los Angeles 90004

Henry Radio Inc.
931 N. Euclid
Anaheim 92801

Henry Radio Co., Inc.
(P.O. Box 64398)
11240 W. Olympic Blvd.
Los Angeles 90064

Weatherby Industrial Electronics
1280 No. Fourth St.
San Jose 95112

COLORADO

Burstein-Applebee Co. of Colorado
800 Lincoln Street
Denver 80202

FLORIDA

Amateur Electronic Supply
19 Azalea Park Shopping Center
Orlando 32807

Electronic Wholesalers, Inc.
9390 NW 27th Avenue
Miami 33147

Grice Electronics, Inc.
330 East Wright Street
(P.O. Box 1911)
Pensacola 32501

Kinkade Radio Supply, Inc.
1719 Grand Central Avenue
Tampa 33606

GEORGIA

Commercial Communications
2752 Church Street
East Point

HAWAII

Honolulu Electronics
819 Keeaumoku Street
Honolulu 96814

LOUISIANA

Thomas J. Morgavy Electronics
3409 Beaulieu Street
Metairie 70001

MARYLAND

Electronic International Service Corp.
11305 Elkin Street
(P.O. Box 1813)
Wheaton

MASSACHUSETTS

Two-Way Radio Engineers, Inc.
1100 Tremont Street
Roxbury 01969

MICHIGAN

Communication Service Company
201 South Lincoln
Charlotte 48813

MINNESOTA

Electronic Center, Inc.
107 3rd Avenue North
Minneapolis 55404

MISSISSIPPI

Coker Radio & TV Service
724 Lawrence Road
Jackson 39206

NEW JERSEY

Communication Service Co.
456 Elm Avenue
Maple Shade 08052

Warner Engineering Co., Inc.
239 Lorraine Ave.
Upper Montclair 07087

NEW MEXICO

Simms Communications Inc.
217 Camino Encantado
Santa Fe 87501

NEW YORK

Electronic Servicercenter of New York
65-37 Queens Blvd.
Woodside 13789

NORTH CAROLINA

Freck Radio & Supply Co., Inc.
38 Biltmore Avenue
Asheville 28801

OHIO

Universal Service
114 N. Third Street
Columbus 43215

OKLAHOMA

Radio, Inc.
1000 South Main
Tulsa 74119

OREGON

Portland Radio Supply Co.
1234 S. W. Stark Street
Portland 97205

TEXAS

Electronic Center, Inc.
2929 N. Haskell
Dallas 75204

Busacker Electronic
Equipment Co., Inc.
(P.O. Box 13204)
1216 West Clay Street
Houston 77019

Electronic Equipment &
Engineering Company
805 South Staples St.
Corpus Christi 78404

Howard Radio Company
1475 Pine Street
Abilene 79601

UTAH

Dwyer's TV & Communications
5455 Knollcrest Street
Murray 84647

WASHINGTON

H CJ Electronics
6904 East Sprague
Spokane 99206

WISCONSIN

Amateur Electronic Supply
4828 W. Fond du Lac Ave
Milwaukee 53208

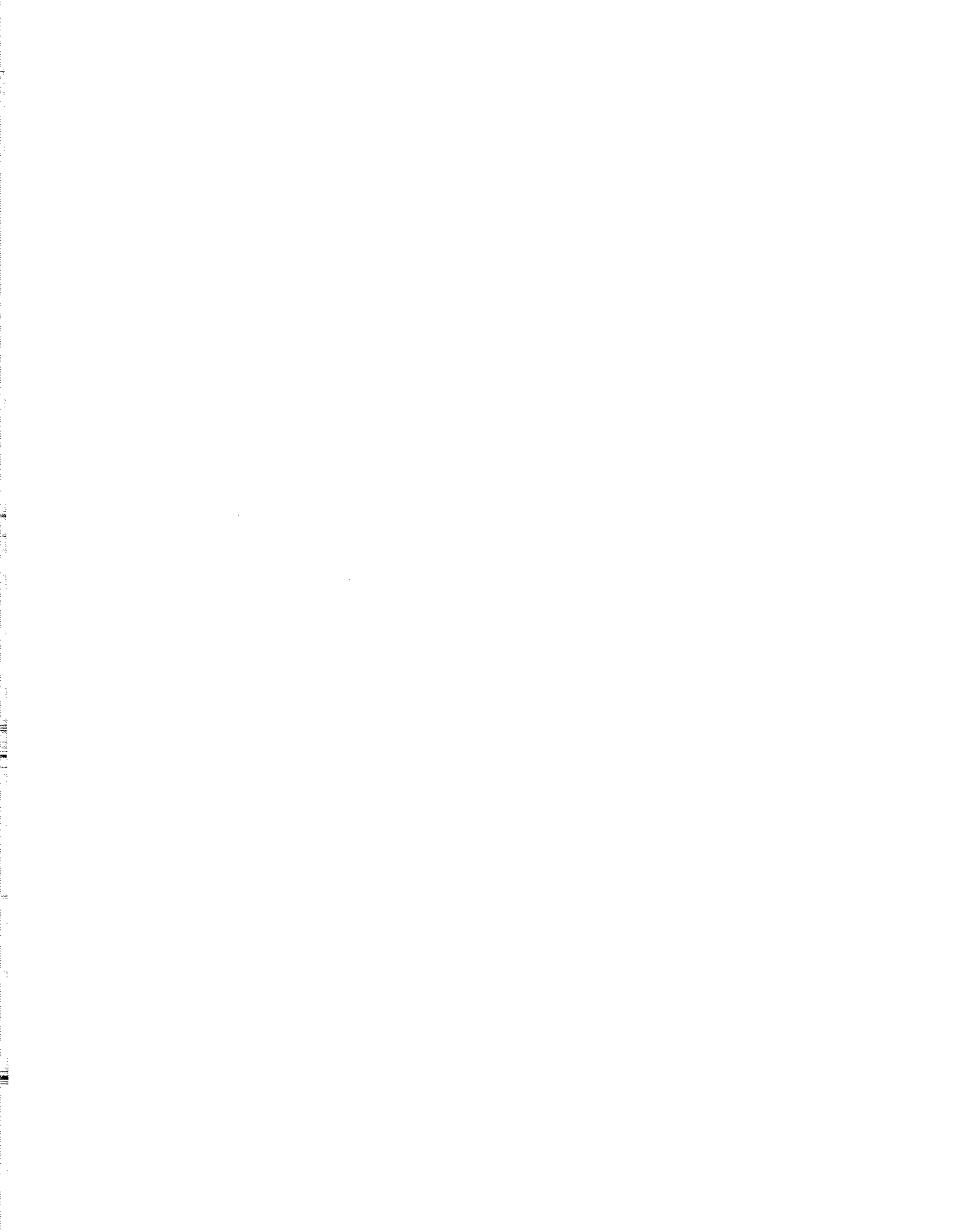

520-5052000-203311
1 March 1955
3rd Edition, 1 December 1956
2nd Revision, 15 July 1957

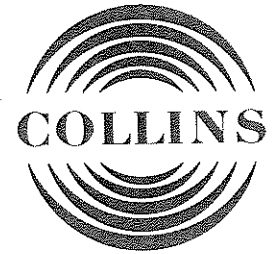

instruction book

75A-4
Amateur Receiver

©Collins Radio Company 1955, 1956, 1957, 1963
Third Printing November 1968
Printed in the United States of America

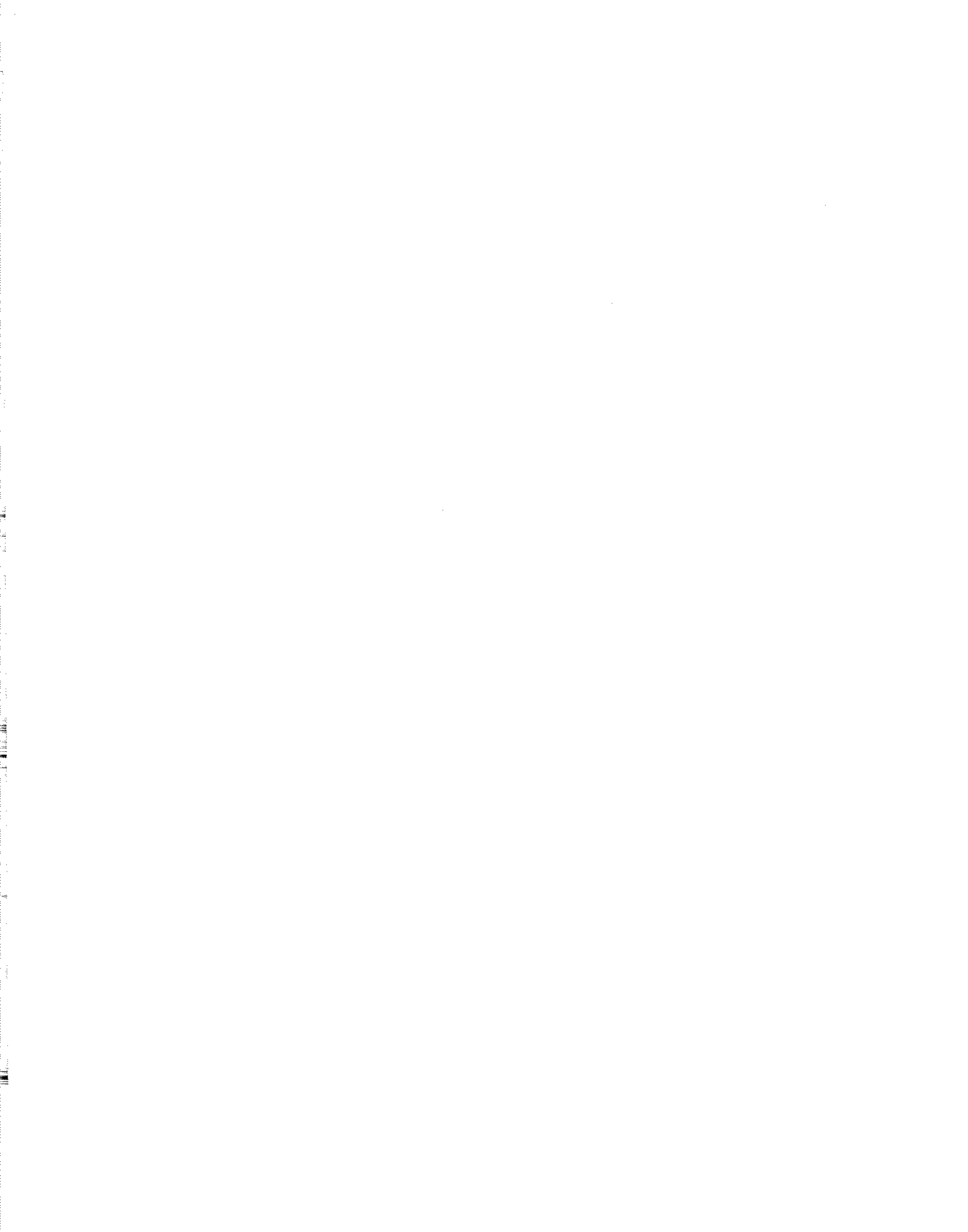

TABLE OF CONTENTS

<u>Paragraph</u>		<u>Page</u>
SECTION I DESCRIPTION		
1.	General	1-1
2.	New Features.	1-1
	a. Detectors	1-1
	b. AVC	1-1
	c. Passband Tuning.	1-1
	d. "Q" Multiplier.	1-1
	e. Mechanical Filters	1-1
	f. Noise Limiter	1-1
	g. Crystal Calibrator	1-1
3.	Specifications.	1-2
4.	Accessories	1-3
SECTION II INSTALLATION		
1.	Unpacking	2-0
2.	External Connections (See figure 2-1)	2-0
	a. Antenna and Ground	2-0
	b. Coaxial Antenna Connection	2-0
	c. Output Connections	2-1
	(1) Speaker	2-1
	(2) Headphones	2-1
	d. 500-Ohm Output.	2-1
	e. Standby	2-1
	f. Muting	2-1
	g. Power.	2-1
	h. Fuse	2-1
3.	Installation of Mechanical Filters	2-1
4.	"S" Meter Adjustment	2-1
5.	Adjustment of Calibration Oscillator	2-1
6.	Use of External Sideband Selecting Devices	2-2
SECTION III OPERATION		
1.	Controls.	3-1
	a. Off-Standby-On Cal.	3-1
	b. Band Change	3-1
	c. Megacycles - Kilocycles	3-1
	d. AM CW-SSB	3-1

TABLE OF CONTENTS (Cont.)

<u>Paragraph</u>	<u>Page</u>
e. Selectivity	3-1
f. RF Gain	3-1
g. Audio Gain	3-1
h. Passband Tuning	3-1
i. Ant. Trim.	3-2
j. Noise Limiter	3-2
k. AVC	3-2
l. Rejection Tuning	3-2
m. Zero Set.	3-2
2. Tuning AM Signals	3-2
3. Tuning Single-Sideband Signals	3-2
4. Tuning CW Signals	3-3
5. Locally Reinserted Carrier	3-3
6. Single-Sideband AM Reception	3-3
7. Passband Tuning	3-3
8. Rejection Tuning	3-4
9. Frequency Measuring	3-5

SECTION IV
THEORY OF OPERATION

1. General.	4-0
2. Tuning	4-0
3. RF Circuits	4-0
a. RF Stage	4-0
b. Crystal Controlled Oscillator and First Mixer	4-2
c. Variable IF.	4-2
d. VFO and Second Mixer	4-2
e. Mechanical Filter	4-2
f. "Q" Multiplier	4-2
g. 455 KC IF Amplifier	4-3
h. AM Detector	4-3
i. CW-SSB Detector	4-3
j. BFO	4-3
4. Audio Circuits	4-3
a. Noise Limiter	4-3
b. Audio Amplifiers	4-4
5. RF Gain Control System	4-4
6. "S" Meter	4-4
7. AVC System	4-4
8. Calibrator Circuit	4-5



TABLE OF CONTENTS (Cont.)

SECTION V
MAINTENANCE

<u>Paragraph</u>		<u>Page</u>
1.	Trouble Shooting	5-0
2.	Fuse	5-0
3.	Test Equipment Required for 75A-4 Alignment	5-0
4.	Preliminary Checks	5-0
5.	455 KC IF Alignment	5-1
6.	Rejection Tuning Alignment	5-1
7.	BFO Alignment	5-1
8.	Variable IF and 160-Meter Band Alignment	5-2
9.	Alignment of Crystal Oscillator	5-3
10.	RF Alignment	5-3
11.	VFO Adjustment	5-4
12.	Tweet Trap Adjustment.	5-4
13.	AVC Threshold (R-9).	5-4
14.	Dial Cords.	5-4
	a. Removing Front Panel	5-4
	b. Pointer Cord	5-5
	c. Drum Cord	5-5

SECTION VI
PARTS LIST FOR 75A-4 RECEIVER

LIST OF ILLUSTRATIONS

<u>Figure</u>		<u>Page</u>
1-1	75A-4 Receiver and Block Diagram (A95-13-P)	1-0
1-2	Type F-455J Plug-in Mechanical Filter (A95-15-P)	1-2
1-3	75A-4 Selectivity Curves (A95-06-2)	1-2
2-1	75A-4 Receiver, External Connections (A95-22-P)	2-0
3-1	75A-4 Operating Controls (A95-16-P)	2-2
4-1	Tuning Elements of RF and Mixer Stages, Simplified Diagram (A95-04-4)	4-1
4-2	A Collins Mechanical Filter, Functional Diagram (A41-406-4)	4-3
5-1	Dial Cord Replacement (A41-406-4)	5-8
5-2	75A-4, Top View (A95-17-P)	5-9
5-3	75A-4, Bottom View, Page 1 (A95-18-P)	5-10
	75A-4, Bottom View, Page 2 (A95-19-P)	5-11
5-4	75A-4, Front Panel Lowered (A95-20-P)	5-12
5-5	75A-4 Receiver, Schematic Diagram (A95-01-6) (540-5686-006)	5-13/14
5-6	Assembling Plug UG-21B/U to Cable RG-8/U (A95-21-P)	5-15
5-7	Dial Divisions Table (A95-08-3)	5-16
5-8	Assembling Plug UG-260/U to Cable RG-58/U (A64-08-3)	5-17



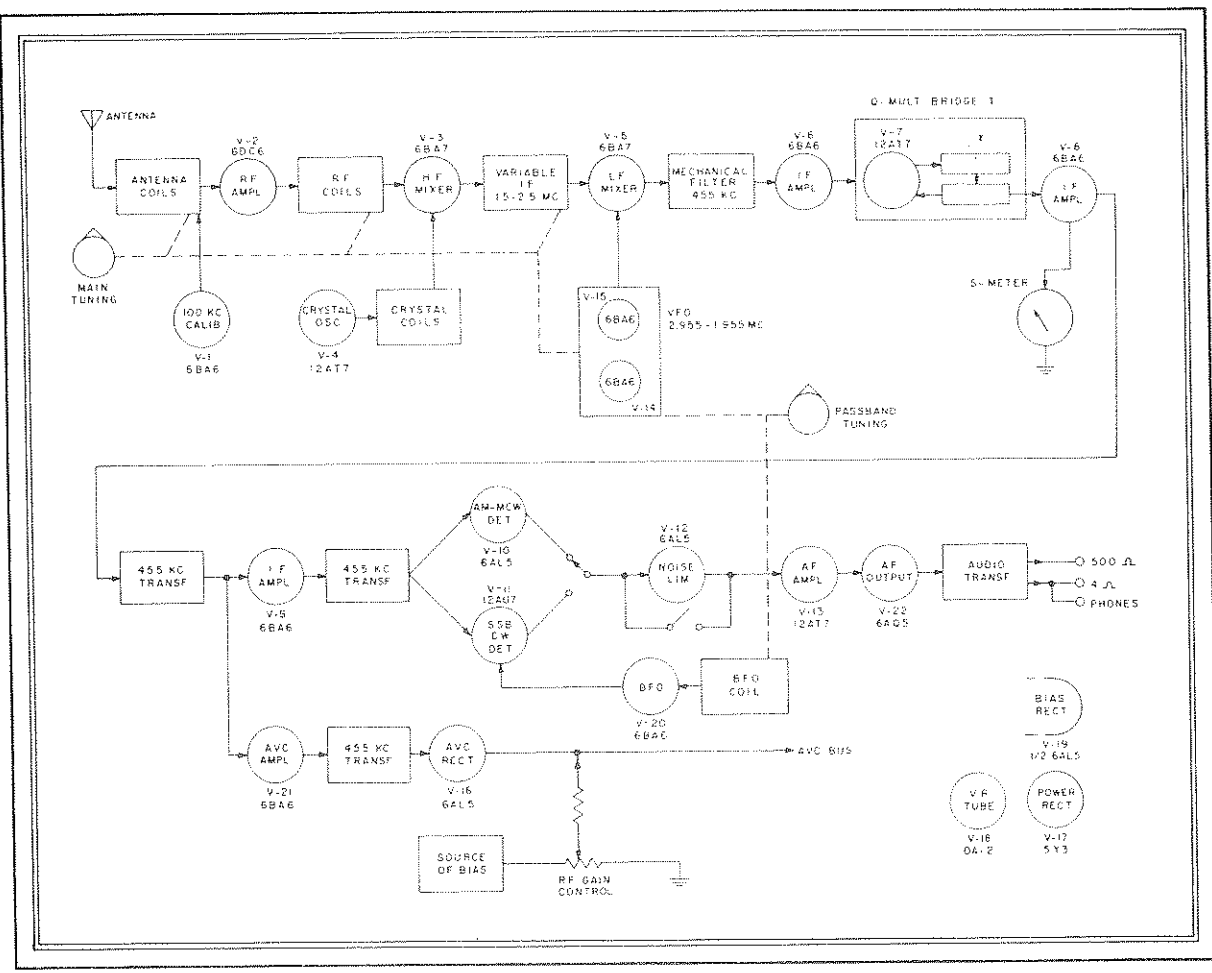
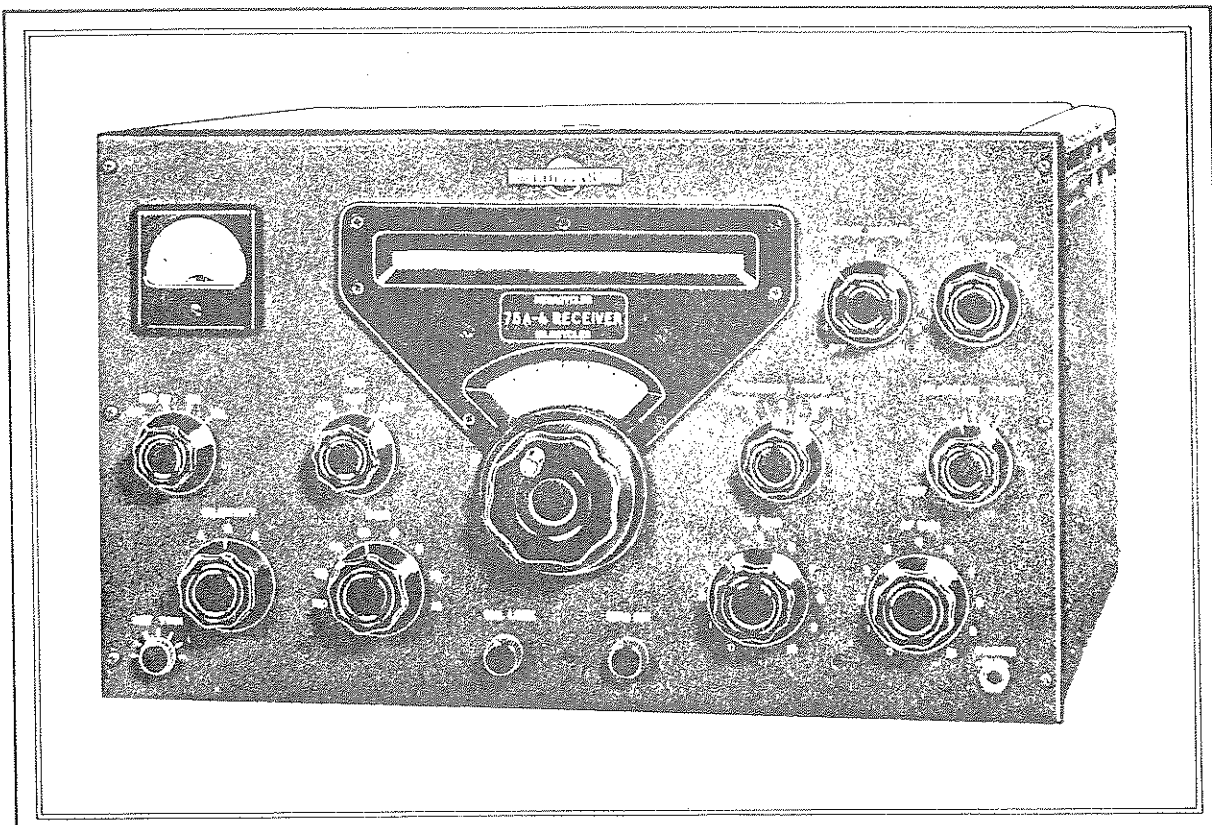

Figure 1-1. 75A-4 Receiver and Block Diagram

SECTION I DESCRIPTION

I. GENERAL.

The Collins 75A-4 receiver is designed primarily for amateur reception on the seven HF amateur bands. It retains many of the time-proven features of the earlier 75A series of receivers. These features include:

- a. Double conversion, crystal controlled front end for high stability and good image rejection even on the 10-meter bands.
- b. Permeability tuned, sealed master oscillator for accurate dial calibration and long-term stability.
- c. Mechanical filters in the IF circuits for the ultimate in selectivity.

2. NEW FEATURES.

Increased amateur activity on single sideband has revealed a need for a receiver designed especially for single sideband reception. The 75A-4 incorporates several new features which considerably improve the ease of reception of a SSSC signal. They include:

- a. DETECTORS. Separate detectors for double or single sideband signals. The sideband detector is a mixer type detector, which greatly reduces the distortion which is generated when a conventional diode detector is used for detecting a SSSC signal. A diode detector is used for conventional double sideband signals.
- b. AVC. A fast attack, slow release AVC system is fast enough to respond to the first few cycles of a sideband transmission and does not require the presence of a carrier for operation. A fast and slow release time are available on a panel switch. The "fast" is used normally for AM reception. The "slow" is used during sideband and CW reception and prevents the receiver from "opening up" between words and characters.

- c. PASSBAND TUNING. A passband tuning system is used in the 75A-4. In this system the receiver BFO is mechanically ganged and tracked with the main tuning dial. Once a SSSC signal is tuned in, it can be moved relative to the passband of the receiver without losing intelligibility of the signal. This feature is especially useful for "switching" sidebands and for dodging interfering signals. In CW reception, the desired signal can be moved around in the passband without changing the pitch of the received beat note, and at the same time, interfering signals can be pushed off the edge of the passband.

- d. "Q" MULTIPLIER. A combination "Q" multiplier and bridge T-filter are used in the 75A-4. This circuit replaces the conventional crystal filter and has several features which make it superior to the crystal filter. It has a deep, narrow notch which has equal effectiveness anywhere in the passband. Conventional crystal filters become inoperative at frequencies several hundred cycles on either side of the resonant frequency of the crystal. The "Q" multiplier does not seriously distort the shape of the HF passband as does a crystal filter. This results in much less loss of intelligibility while still doing a superior job of eliminating heterodynes.

- e. MECHANICAL FILTERS. Space has been provided for 3 mechanical filters. This allows the operator to tailor his set to his requirement. An 800-cycle filter is available for CW use and a 6-KC filter for double sideband AM reception. The 75A-4 is normally supplied with one 3-KC filter as standard equipment.

- f. NOISE LIMITER. A new noise limiter circuit which is effective on AM, CW or SSSC signals is used in the 75A-4. This limiter is designed to clip both the positive and negative peaks of the detected signal. By means of a panel control the operator can select the degree of clipping desired.

- g. CRYSTAL CALIBRATOR. A crystal calibrator circuit is an integral part of the 75A-4. No adapters are needed. Calibration signals are present every 100 KC at the flip of a panel switch.

Section I
DESCRIPTION

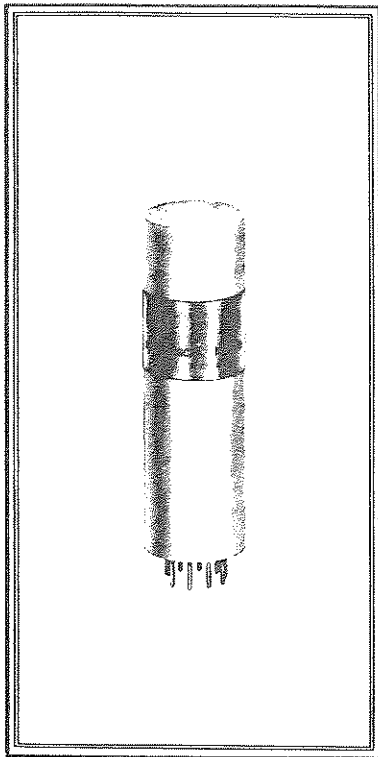

Figure 1-2. Type F-455J Plug-in Mechanical Filter.

3. SPECIFICATIONS.

<u>Frequency Range:</u> -	<u>Band (meters)</u>	<u>Range (mc)</u>
	160	1.5 to 2.5
	80	3.2 to 4.2
	40	6.8 to 7.8
	20	14.0 to 15.0
	15	20.5 to 21.5
	11	26.5 to 27.5
	10	28.0 to 29.0
	10	29.0 to 30.0

Size: - 10-1/2" high x 17-1/4" wide x 15-1/2" deep.

Weight: - 35 pounds.

Finish: - St. James gray wrinkle enamel.

Cabinet: - Table mounted with provision for relay rack mounting.

Power Input: - 105-125 volts AC, 50-60 cps: 85 watts.

Number of Tubes: - 22, including rectifier and voltage regulator tubes

Types of Reception: - AM, CW, SSB, MCW.

Sensitivity: - 1.0 microvolt for 6 db signal-to-noise ratio with 3 KC bandwidth.

Antenna Input: - Accommodates wide range of antenna impedances; designed for 50-150 ohms terminal impedance; coax connector provided.

Selectivity: - The selectivity is determined entirely by the choice of mechanical filters. Provision is made for use of three filters. Filters are available in bandwidths of 0.8 KC, 3.1 KC and 6 KC. Use only the filters here listed: F-455J-05 (Part No. 526 9154 00) for 500 cps; F-455J-31 (526 9089 00) for 3.1 KC; F-455J-60 (526 9091 00) for 6 KC. Receiver supplied with 3.1 KC filter (F-455J-31).

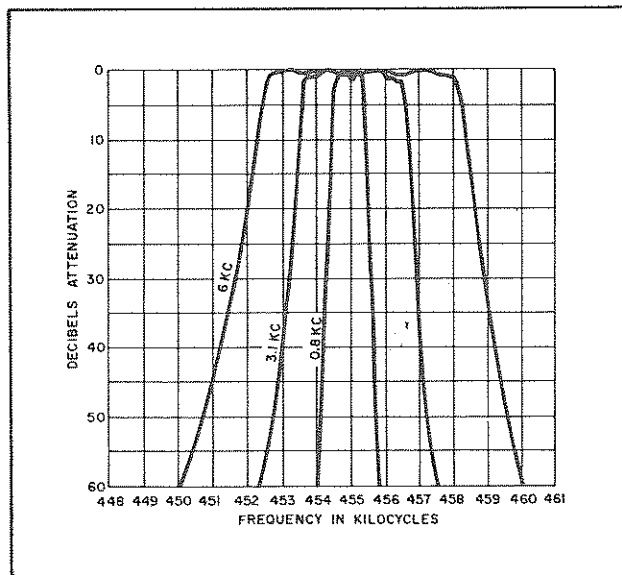

Figure 1-3. 75A-4 Selectivity Curves

AVC Characteristics: - Audio rise less than 3 db for inputs of 5 to 200,000 uv.

AVC Time Constants: -

	<u>Fast</u>	<u>Slow</u>
Rise Time	.01 sec.	.01 sec.
Release Time	.1 sec.	1 sec.

IF and Image Rejection: - All greater than 50 db down.

Audio Characteristics: -

Output - .75 watts with a 3.0 uv signal, 30% modulated.
Output impedance - 500 ohms, 4 ohms.
Response of audio circuits - ± 3 db 100 cps to 5000 cps.
Distortion - Less than 10%.

Noise Limiter: -

AM - Adjustable clip point, automatic carrier reference.
CW-SSB - Adjustable clip point. Clip reference controlled by flat AVC.

Muting: - Provisions for muting the receiver during key-down operation is provided. A muting voltage of +20 volts must be supplied by the transmitter or a separate contact on a keying relay and a 20 volt "B" battery.

Frequency Stability (at 14.5 mc): -

Temperature - Not more than 1200 cycles drift, from 0 degrees to +60 degrees centigrade.

Warmup - After 30-minute warmup, drift during any 10-minute period does not exceed 100 cps.
Voltage - For line voltage changes of $\pm 10\%$, the frequency does not change more than 100 cps.
Humidity - For humidity changes of from 0 to 90%, the frequency does not change more than 50 cps.
Dial Accuracy - (After calibration)
All Bands - ± 300 cps.

4. ACCESSORIES.

In addition to the mechanical filters listed in paragraph 3 above, the following accessories are available:

Speaker - 10" speaker in matching cabinet, speaker cabinet 15" wide, 11-1/8" high, 9-1/8" deep. Type No. 270G-3. Part No. 522 0149 00.

Rack Mounting Bracket Assembly: - To adapt the receiver for standard relay rack mounting. St. James Gray wrinkle finish. Part No. 540 4628 00.

SECTION II INSTALLATION

1. UNPACKING.

Open packing cartons carefully to prevent damage to the equipment. Remove packing material and remove the equipment from the cartons. Search the packing material for small packages. Inspect the receiver for loose screws and bolts. Check all knobs, switches, etc., to see that they operate properly. Any claims for damage should be filed promptly with the transportation company. If a claim is to be filed, the original packing case must be preserved. See instructions on back of the bill of lading.

2. EXTERNAL CONNECTIONS (See figure 2-1).

a. ANTENNA AND GROUND. The antenna connector strip is located at the rear of the chassis on the right-hand side. Balanced antennas should be connected to terminals 1 and 2. When a balanced antenna is used, grounding terminal G may introduce noise. Therefore, to determine the more satisfactory arrangement, try the receiver both

with and without an external ground. A single-wire antenna should be connected to terminal 1 with terminals 2 and G connected together and grounded.

b. COAXIAL ANTENNA CONNECTION. The 75A-4 is provided with a UG-1094/U receptacle and UG-260/U plug for use with coaxial cable antenna input. Jumper terminal 2 of the antenna connector strip to G. Figure 5-8 shows the proper method for assembling plug UG-260/U to RG-58/U cable.

CAUTION

Do not subject the antenna input to RF exceeding 50 volts. Excessive RF voltages may be encountered if the receiving antenna is not disconnected when the transmitter is operating. Excessive capacity coupling across contacts of the antenna change-over relay may also result in excessive RF voltage when the transmitter is operating. If an RF voltmeter is not available, a small neon bulb connected at the receiver terminals will serve as an indicator of harmful RF voltage.

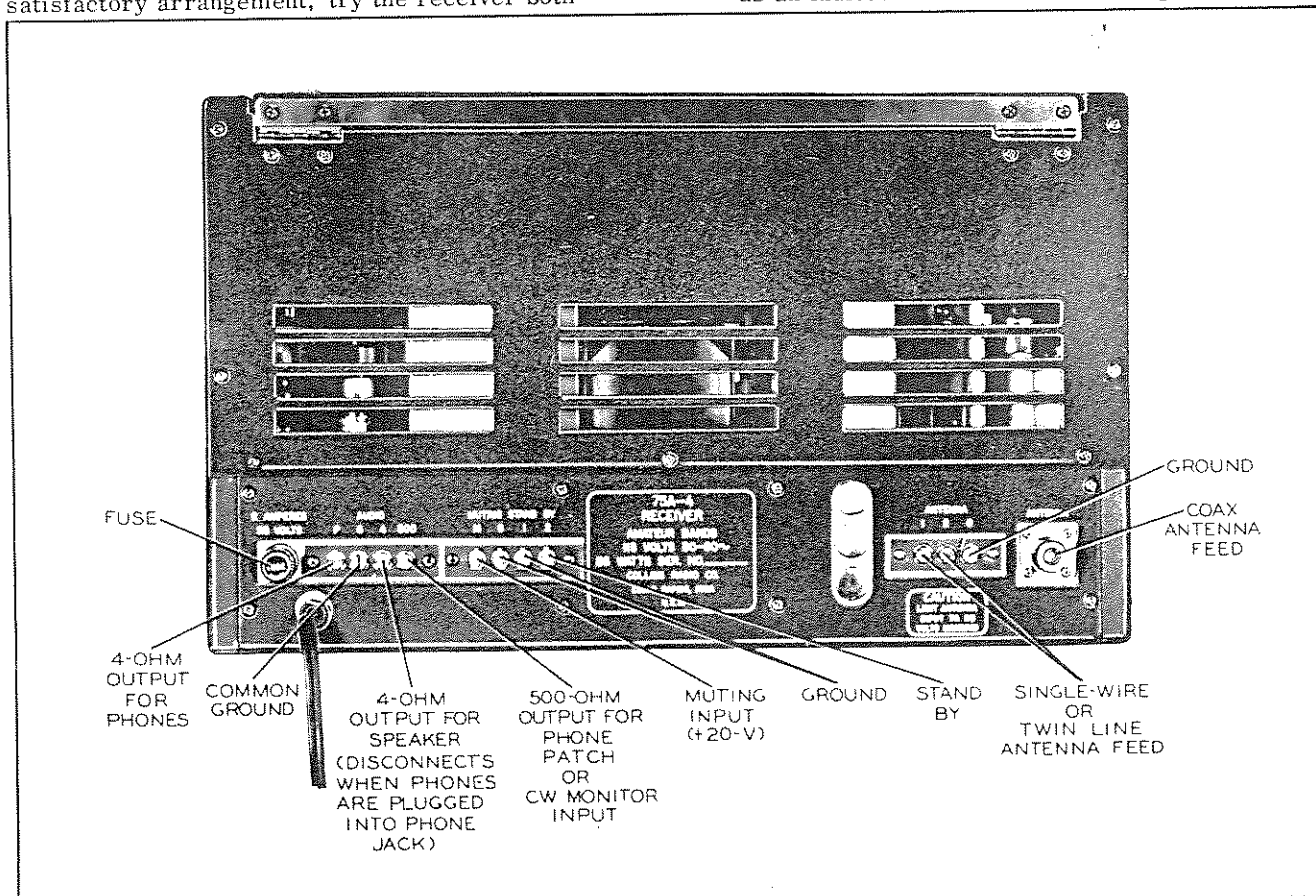

Figure 2-1. 75A-4 Receiver, External Connections

c. OUTPUT CONNECTIONS.

(1) SPEAKER. The output connections are on the rear of the chassis at the left-hand side. Terminals G and 4 are for connection to a speaker voice coil. This output is open circuited by the headphone jack on the front panel so that plugging in headphones disables the speaker.

(2) HEADPHONES. In addition to the front-panel jack, a pair of terminals marked G and P is provided for rear-chassis headphone connection. This output is connected to the 4-ohm tap on the output transformer and is not open circuited by the front-panel jack.

d. 500-OHM OUTPUT. These terminals may be used to feed a transmitter or telephone line for phone patch, or may be connected to a sidetone oscillator or monitor.

e. STANDBY. The standby terminals, marked 1 and 2, are located at the rear of the chassis on the center terminal strip. These terminals are across a blocking bias resistor and are in parallel with contacts on the OFF-STANDBY-ON CAL switch. The terminals may be connected to contacts of a send-receive relay for external standby control. With the OFF-STANDBY-ON CAL switch in STANDBY position, closing the standby circuit will allow the receiver to operate. Opening the standby circuit will disable all tubes which are connected to the AVC line.

f. MUTING. Terminals M and G on the center terminal strip at the rear of the chassis are provided for connection to a source of muting voltage for break-in CW operation. This source must be capable of delivering +20 volts to the terminals for key-down muting and 0 volts key-up. The Collins 32V-1, 32V-2, and KW-1 transmitters provide a muting voltage.

The muting voltage may be obtained from the cathode resistor of a keyed stage which is biased to cutoff during key-down conditions, from a resistor in series with a cathode-keyed stage, or from a battery in series with auxiliary contacts on a keying relay. Terminal G must be connected to a point of ground potential and terminal M to the source of positive voltage.

NOTE

Neither the disabling nor the muting circuits provide protection to the antenna input circuit. See part 2 of this section, paragraph b.

g. POWER. The receiver must be powered from a 115-volt, 50/60 cps source.

h. FUSE. The fuse is in an extractor-type fuse post located on the rear of the chassis near the left-hand corner. To remove the fuse, push in the fuse-post cap, turn it counterclockwise, and pull straight out. Use only a 2-ampere fuse.

3. INSTALLATION OF MECHANICAL FILTERS.

If the receiver was shipped with the mechanical filter (or filters) removed, open the receiver lid and loosen the filter clamp wing nut and remove the clamp. Plug the filter all the way in (very important to prevent feedthru) and replace the filter clamp. Shove the clamp down tightly and tighten the wing nut. Use socket B for 3 KC, socket A for 800 cps, and socket C for 6 KC filters.

4. "S" METER ADJUSTMENT.

Set up the receiver for AM operation (section III, part 2), short the antenna input connections, and set the ZERO-ADJUST Control, located on top of the receiver chassis, for an "S" meter reading of 0.

NOTE

The METER SENSITIVITY Control is set at the factory by injecting a 100 uv, 3.7 MC signal into the ANT input and adjusting for an S-9 reading of the "S" meter.

5. ADJUSTMENT OF CALIBRATION OSCILLATOR.

Turn the set on and allow it to warm up for about 20 minutes. During this 20-minute period, read Section III OPERATION and tune around the bands and get the "feel" of the set. After the set is warmed up, tune in a signal of known accuracy (WWV at 2.5, 15, or 30 MC is suggested). Turn the OFF-STANDBY-ON CAL Control to CAL, switch to AM and center the PASSBAND TUNING knob. If an audible beat note is heard, lift the receiver lid and locate the CAL adjusting capacitor in the left-hand, rear corner of the chassis. Be sure not to confuse the tone modulation, when present, on WWV with the beat note. Turn this capacitor until zero beat is obtained. The calibrator is now adjusted. Check for a signal at several 100-KC points on the tuning dial.

Section II
INSTALLATION

6. USE OF EXTERNAL SIDEBAND SELECTING DEVICES.

Do not use the 75A-4 with external sideband selecting devices. These arrangements which have become popular for single sideband reception with other types of receivers should not be employed

with the 75A-4. These devices were intended to provide rejection of an unwanted sideband, selection of either sideband, and carrier reinsertion. Each of these functions is performed by the normal circuitry of the 75A-4 and in a more convenient and effective manner than would be accomplished with such devices.

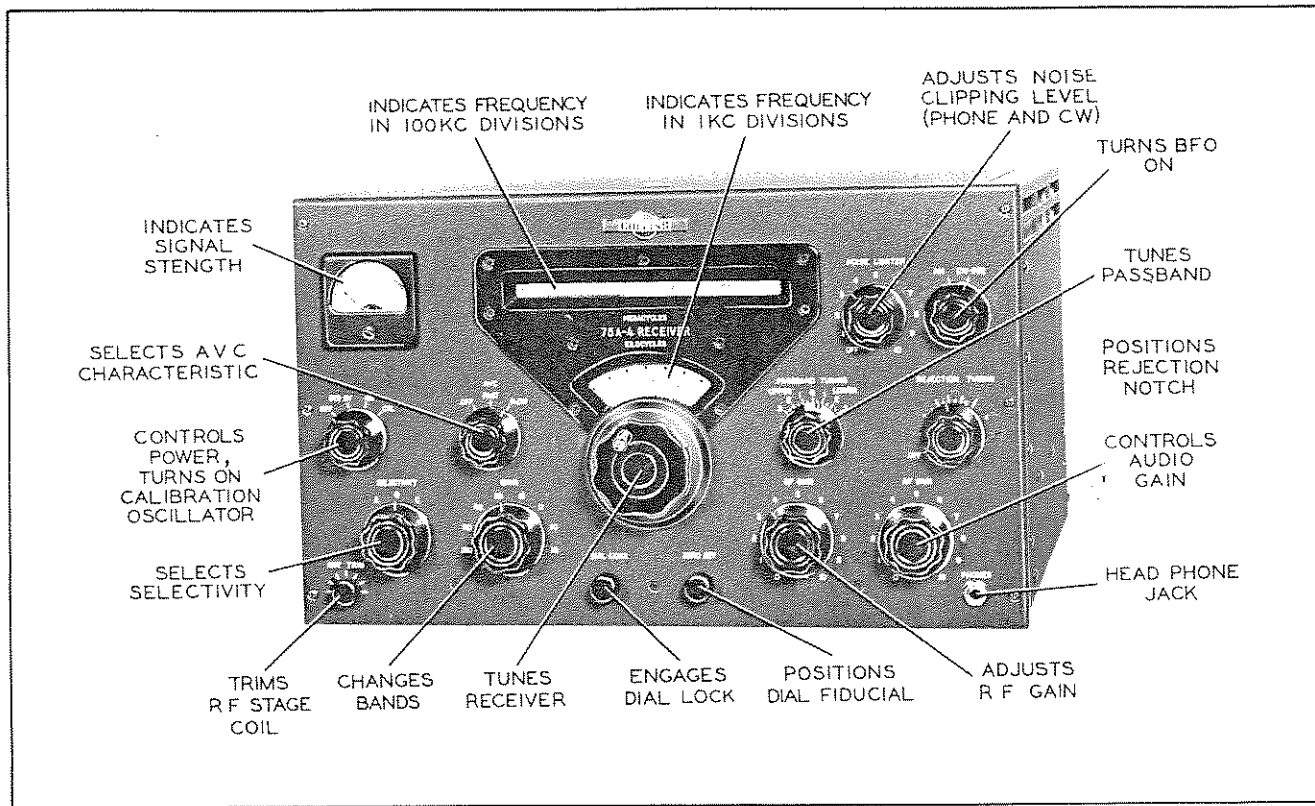

Figure 3-1. 75A-4 Operating Controls

SECTION III OPERATION

I. CONTROLS.

a. OFF-STANDBY-ON CAL. This switch turns the receiver power on and off and in STANDBY position allows filament and plate voltages to remain on but disables the receiver. In the CAL position, plate and filament power remain on and B+ is applied to the calibration oscillator. In STANDBY position, a resistor, R-98, is inserted in series with the bias load resistors to increase the bias voltage to cutoff on the output tube and the AVC controlled tubes. Standby terminals 1 and 2 on the rear of the chassis are connected across R-98 to allow the use of an external send-receive switch or relay to control the standby function. This connection would be effective with S-6 in STD BY position.

b. BAND CHANGE. This switch is used to select the desired amateur band. Turning the control knob turns the shaft of the band switch and at the same time rotates the dial drum so that the scale in use is visible through the MEGACYCLES window. The 10-meter band occupies 2 positions of the switch; all other bands one position.

c. MEGACYCLES - KILOCYCLES. The main tuning dials are a slide-rule MEGACYCLES dial and circular KILOCYCLES dial. The MEGACYCLES dial is calibrated in 100-KC divisions on each scale. The scale for each band is 1 megacycle wide. The KILOCYCLES dial is calibrated in 1-KC divisions. The KILOCYCLES dial has two scales; the lower scale is black, and is calibrated in 1-KC divisions for 80 - 10 meters; and the upper scale, also marked in 1-KC divisions, is red, and is used on 160 meters. The 160-meter scale is separate from the black scale because kilocycle readings on this band run in the opposite direction from those on the other bands.

Scales on the MEGACYCLES dial are colored to correspond to the colors on the KILOCYCLES dial.

The frequency at which the receiver is set is determined by combining the readings of the two dials. For example, if the MEGACYCLES scale reads 3.8 plus and the KILOCYCLES scale reads 52, the receiver is tuned to 3852 KC; or if the MEGACYCLES dial reads 28.6 plus and the KILOCYCLES

dial reads 32, the receiver is tuned to 28,632 KC. For frequency measuring procedures, refer to part 9 of this section, FREQUENCY MEASURING.

d. AM CW-SSB. In the CW-SSB position this switch turns on the BFO, selects the CW-SSB detector V-11, and puts fixed operating bias on the noise limiter. In the AM position, this switch turns off the BFO, selects the AM-MCW detector, and removes the fixed bias from the noise limiter and connects the noise limiter to the carrier source of bias.

e. SELECTIVITY. This control selects the sockets into which the mechanical filters are inserted. It is suggested that the 3-KC filter be inserted into socket B, socket A be reserved for an 800-cps filter, and socket C be reserved for a 6-KC filter. The panel is marked to conform with the socket lettering.

f. RF GAIN. This control is used to set the maximum RF and IF gain of the receiver so that the AVC will not increase the gain excessively between characters in CW or between words and syllables in SSB reception. The 75A-4 should always be used with AVC for all types of signals. The AVC OFF position is provided merely for test and special purposes. The RF GAIN Control is normally set so that the S meter "kicks up" about three S points or 20 db during keying or SSB reception. Adjustment of the RF GAIN Control does not disturb the reading of the S meter provided it is set so that the S meter rises in the presence of a signal. For exact tuning and operating procedures, refer to parts 2-8 of this section.

g. AUDIO GAIN. This control is used to adjust the gain of the first audio stage. It should be employed to adjust the loudness or volume of the receiver. The RF GAIN Control should not be used for this purpose either on CW or voice reception.

h. PASSBAND TUNING. The shaft of this control is connected directly to the BFO tuning condenser and is connected by a belt drive to the frame of the master oscillator (KILOCYCLES tuning). Its function is explained in part 7.

Section III
OPERATION

i. **ANT. TRIM.** This control should be adjusted for maximum RF gain each time a different band is used. The control shaft is coupled to a trimmer capacitor across the RF coil for the band in use and is used to compensate for changes in antenna characteristics from one band to another.

j. **NOISE LIMITER.** The noise limiter functions for both AM and CW-SSB operation. The NOISE LIMITER is out of the circuit when the control is in the OFF position. When the control is advanced from the OFF position, the noise limiter is connected into the circuit. Advancing the control toward higher numbers increases the noise limiting action on both AM and CW-SSB. Use the noise limiter on phone only when the need arises because, as with all noise limiters, some distortion is introduced with its use.

k. **AVC.** The AVC Control can turn off the AVC altogether or it can select either fast release or slow release AVC characteristics. In both cases the AVC is fast attack, the release time being the selectable characteristic. The FAST position is used for AM operation. The SLOW is used for SSB operation and for CW operation because it prevents the receiver from "opening up" between words or CW characters.

l. **REJECTION TUNING.** This control takes the place of the usual crystal filter phasing control. In operation, it is much more effective than the crystal filter phasing control in reducing heterodyne interference. The control tunes the rejection filter through the entire receiver passband. To remove the filter from the circuit, turn the control to OFF. See part 8 for operational procedures.

m. **ZERO SET.** Rotating the ZERO SET knob moves the indicator line on the KILOCYCLES dial. This adjustment allows exact calibration of the KILOCYCLES dial on a signal of known frequency. Calibration procedures are described in part 9 of this section, FREQUENCY MEASURING.

n. **DIAL LOCK.** This knob locks the KILOCYCLE dial when desired. It should be unlocked for all normal tuning procedures.

2. TUNING AM SIGNALS.

The tuning techniques used with a 75A-4 receiver when employing the 3-KC filter differ somewhat from those used in tuning a conventional receiver. Because of the flat top and almost vertical sides of the passband, it is possible to tune either sideband of an AM station and reject the opposite sideband.

Tuning "on the nose" results in loss of the high frequency audio components with a loss of intelligibility. Select the sideband that contains the least objectionable adjacent channel interference. Use the following procedure to tune AM signals.

a. Setup for AM reception. Power on. Operate BAND CHANGE switch to desired band. Select 3-KC mechanical filter. RF GAIN maximum. Use AUDIO GAIN for volume control. Set for FAST AVC. Set PASSBAND tuning for LOWER sideband as described below.

NOTE

Tuning is reversed on 160 meter band. Set PASSBAND knob at UPPER to receive lower sideband, etc.

b. Tune in AM station for maximum S meter reading.

c. Adjust antenna trim for maximum S meter reading. (One setting for each new band usually sufficient.)

d. Tune the receiver counterclockwise (clockwise on 160 meters) or to low frequency side of the signal until the S meter reading drops sharply. Then back up the tuning until the S meter reading just regains its former value and the modulation is readable. The receiver is now tuned to accept the lower sideband and the carrier of the AM station. If interference is present, it may be possible to avoid it by setting the PASSBAND TUNING to accept the carrier and the upper sideband. The same result can be obtained by adjustment of the main tuning control except that if the main tuning control is used for this purpose instead of the PASSBAND TUNING, the dial will no longer read the exact carrier frequency of the received signal.

e. If impulse noise is severe, advance the NOISE LIMITER Control from the OFF position far enough to reduce the impulse noise but not so far as to distort the modulation appreciably.

f. If heterodyne interference is bad on both sidebands, tune to the better sideband. Operate the REJECTION TUNING Control over its entire range (90° either side of center position) to find the position at which the heterodyne is weakest.

g. If interference is not severe, some improvement in reception may be experienced by switching to the 6-KC mechanical filter if one is available.

When the 6-KC mechanical filter is used, the PASSBAND TUNING should be centered and the receiver should be tuned to place the carrier in the center of the passband.

3. TUNING SINGLE-SIDEBAND SIGNALS.

a. Setup for CW-SSB reception. Operate BAND CHANGE switch to desired band. Select 3-KC mechanical filter. RF GAIN 8 to 10. AUDIO GAIN for normal volume of about 2. AVC - SLOW. PASSBAND TUNING set for desired sideband. Usual amateur practice is to employ the lower sideband on the 4 and 7 bands and the upper sideband on the 14, 21, and 28 mc bands. Occasionally amateurs do not follow this rule, in which case it will be necessary to switch sidebands by resetting the PASSBAND TUNING accordingly. On 160 meter band, set PASSBAND TUNING to LOWER to receive upper sideband and to UPPER to receive lower sideband.

b. Tune in SSB station very slowly until signal is readable. Some care is necessary in the final adjustment of tuning in order to set the frequency sufficiently accurately to make the voice sound entirely natural.

c. If the signal cannot be made readable, turn PASSBAND TUNING to the other side of zero and repeat the tuning procedure.

d. Readjust the RF GAIN Control until the S meter kicks up not to exceed three S points or 20 db with the voice modulation. If the S meter kicks much more than this with the modulation, a popping or pumping effect will be observed due to the necessary attack time of the AVC. The RF GAIN Control can be set so that the S meter does not kick up, but if this is done a weaker station breaking in on the same frequency may not be received.

e. The PASSBAND TUNING can be displaced slightly from its normal setting from either the upper or lower sideband in order to minimize interference which may be present at the edges of the sideband. The NOISE LIMITER can also be used to reduce impulse noise interference.

4. TUNING CW SIGNALS.

The receiver is set up for CW reception in exactly the same way as it is set for SSB reception. Namely, set switch for CW-SSB, power on. BAND CHANGE switch to desired band. Select 3 KC mechanical filter. RF GAIN 8-10. AVC-SLOW. AUDIO GAIN for desired headset or speaker volume.

a. Set PASSBAND TUNING in the normal position for either sideband (not centered).

b. Tune CW station to give a beat note of 1000 to 1500 cycles.

c. If the CW station is being interfered with, turn PASSBAND TUNING one way or the other to drop off interfering station and to retain the wanted station.

d. The REJECTION TUNING may also be used to eliminate an interfering station.

e. If an 800-cycle filter is available, it may be selected and the PASSBAND TUNING readjusted to place the signal in its narrow passband and to accomplish a further reduction of interference and noise.

f. The NOISE LIMITER can be advanced to reduce impulse noise interference.

g. The RF GAIN Control can be adjusted so that the S meter kicks up only sufficiently to provide an S meter reading during keying and so that the gain of the receiver does not recover excessively between characters. Some AVC action should be retained, however, in order to make sure that a weaker breaking station will be heard.

5. LOCALLY REINSERTED CARRIER.

Locally reinserted carrier technique can be employed to advantage where selective fading is causing difficulty in reading an AM signal. The tuning procedure eliminates the station's carrier and substitutes the 75A-4 BFO for use as steady source of carrier power. Combining the station's sideband with the BFO carrier in the 75A-4 receiver produces the intelligible signal. Proceed as follows:

a. Set receiver up for SSB reception and tune the signal for greatest intelligibility as in SSB reception. (See part 3 of this section.)

6. SINGLE-SIDEBAND AM RECEPTION.

Some AM transmitters employ only one sideband. This is accomplished with a single-sideband transmitter by reinserting carrier after phasing out or filtering out one of the sidebands. It has the advantage of permitting reception on an ordinary AM receiver and at the same time occupying only half the spectrum space of an "old-fashioned" double-sideband AM transmitter. The disadvantage, of course, is that the full power of the transmitter

Section III OPERATION

can not be employed in the voice sideband and also that a carrier, which may produce continuous interference, is transmitted. Single-sideband AM signals of this type can be received with the 75A-4 receiver set for AM, except that the receiver must be adjusted to correspond to the sideband being transmitted.

7. PASSBAND TUNING.

Previous receivers have been inconvenient to tune for CW or SSB reception because there has been no way of varying the position of the passband without at the same time disturbing the frequency of the beat note. It is, of course, necessary to have a BFO correctly positioned in respect to the passband in order to obtain proper voice reception in the case of SSB, and in order to obtain a suitable beat note in CW reception while at the same time accepting the desired signal and rejecting others. This difficulty in tuning conventional receivers has been aggravated by the fact that the BFO tuning usually was not accurately calibrated and many BFO's were subject to drift and instability. The 75A-4 overcomes these difficulties through the use of a stable, temperature-compensated and calibrated BFO arranged with a mechanical linkage to the VFO tuning. The PASSBAND TUNING Control varies the frequency of the BFO and at the same time produces an equal and opposing change in the VFO frequency by rotating the case of the VFO. Since the tuning of both oscillators is linear, it is possible to make this tuning track closely at all points. The net effect, then, of turning the BFO tuning control is to maintain the reinserted carrier (BFO injection) frequency unchanged relative to the received signal, but at the same time to change the tuning of the receiver in respect to the IF passband. In this way it is possible to use the main tuning control to "zero in" on an SSB signal or to adjust a CW beat note to the desired frequency and then to use the PASSBAND TUNING Control to select the desired sideband in the case of SSB or to dodge interference in the case of CW without disturbing the beat frequency.

Use of the PASSBAND TUNING Control has been described in the preceding sections. Once its purpose and method of operation is understood, its use will become second nature. It will be observed that the PASSBAND TUNING knob has a white sector which spans approximately 3 KC of the panel calibration. It thus forms a graphic representation of the passband displayed against the panel calibration with zero representing the position of the carrier frequency. The smaller black sector in the middle of the white sector represents the width of an 800

cycle filter and thus the same picture is presented when this narrower filter is employed in CW reception.

It is important when first placing the receiver in operation and at occasional intervals thereafter to check the calibration of the BFO to make sure that it is correctly set. The calibration adjustment can be accomplished most readily as follows:

- a. Set PASSBAND TUNING on center.
- b. Tune the receiver to a calibration check point on one of the higher frequency bands. Adjust for zero beat.
- c. Rotate the PASSBAND TUNING each way until the S meter drops about three S points or 20 db and note the position of the center index mark on the PASSBAND TUNING knob at which this drop is obtained. A 20 db reduction in S meter reading should occur symmetrically on each side of zero and at about 1.5 KC as indicated by the line in the center of the white sector on the knob (using a 3 KC filter). If the drop off is not symmetrical, remove the plug from the top of the BFO can and make a small change in the setting of the adjustable slug. Retune the main tuning for zero beat and see if the drop off points are more symmetrical around zero than before. Repeat until the correct setting of the inductance slug is found. Ordinarily this adjustment would not be needed or, at most, very infrequently. Complete BFO alignment procedures are given in section V, part 7.

The PASSBAND TUNING Control, of course, serves as a "sideband switch." Positioning the white sector either side of zero serves to select either the upper or lower sideband without re-tuning the receiver.

8. REJECTION TUNING.

This control is used to minimize interference caused by heterodynes. It is usually placed in the OFF position until a heterodyne is experienced. Tune the REJECTION TUNING very carefully until the most bothersome heterodyne is eliminated or greatly attenuated. When the UPPER sideband is being received, low frequency heterodynes will be attenuated in the region left of center mark. High frequency heterodynes will be attenuated in the region right of the center mark. When the LOWER sideband is being received, low frequency heterodynes will be attenuated in the region right of center and high frequency heterodynes to the left of center. The null for any audio tone is very sharp so the knob must be moved very slowly.

9. FREQUENCY MEASURING.

The KILOCYCLES dial reads the true carrier frequency if the station is tuned to zero beat.

NOTE

See part 5 of section II for calibration oscillator adjustment.

a. Calibration: Frequency readings will be more accurate if the calibrator is used to calibrate the dial before frequency measurements are made. To use the calibrator, set up for CW reception (part 4 of this section), tune to the 100-KC point nearest

the frequency to be measured, set the PASSBAND TUNING Control to center position, and turn on the calibrator. Zero beat the calibrator signal, using the main tuning control. Adjust the ZERO SET knob so that the dial marker lines up with zero on the KILOCYCLES dial. Turn off the calibrator.

b. To measure the carrier frequency of an AM station, select CW operation, set PASSBAND TUNING to 0, tune the station for zero beat, and read the frequency on the tuning dial.

c. With the single-sideband station properly tuned in the suppressed carrier frequency is the KILOCYCLES dial reading.

SECTION IV THEORY OF OPERATION

1. GENERAL

Refer to the block diagram of figure 1-1. The 75A-4 amateur band receiver is a dual conversion receiver on all bands except 160 meters where single conversion is employed. The dual conversion scheme employs a fixed high frequency oscillator, crystal controlled, and a variable first intermediate frequency. The signal from a type 70E-24 VFO is beat against the variable IF to produce a fixed 455 KC second intermediate frequency. One stage of RF amplification is employed in the receiver. The passband of the fixed IF (455 KC) is shaped by a mechanical filter stage. A "Q" multiplier stage provides a tunable notch to minimize heterodyne interference. Two more 455 KC IF stages follow the "Q" multiplier. These feed separate detectors for AM or CW-SSB reception. The output of the detectors feed a combination AM and CW type adjustable noise limiter. Three stages of audio amplification follow. The output stage feeds a headset jack and a 500-ohm load or a 4-ohm speaker. A separate AVC amplifier and rectifier are used. Bias for the audio output tube and the RF gain control system is obtained from a separate rectifier. A built-in 100-KC calibration oscillator is included in the set. The passband tuning feature is accomplished by gang tuning the BFO and variable frequency oscillator by means of a metal belt.

2. TUNING.

All variable tuned stages including the RF stage, the first mixer, the variable IF system and the variable frequency oscillator are operated by the KILOCYCLES dial. This dial is coupled directly to the shaft of the variable frequency oscillator. All other variable tuned circuits just mentioned are tuned by a common platform to which powdered iron slugs are attached. The platform is moved up and down at a linear rate by means of a mechanism which is coupled to the VFO shaft by a system of split gears and metal belts. The receiver uses a unique method of band switching in the RF stage in which only the 80-meter (T-2) and the 160-meter (T-1) coils are tuned by the main tuning mechanism, and coils for 40-10 meters are selected and connected across the 80-meter coil. Varying the inductance of

the 80-meter coil varies the total inductance, and therefore the resonant frequency of the tuned circuit in use.

3. RF CIRCUITS.

A simplified block diagram of the 75A-4 RF system is shown in figure 4-1. The RF stage V-2 feeds the mixer at the carrier frequency of the incoming signal. The coverage of each band is as follows:

160 meters	-	1.5	-	2.5	MC
80 meters	-	3.2	-	4.2	MC
40 meters	-	6.8	-	7.8	MC
20 meters	-	14.0	-	15.0	MC
15 meters	-	20.5	-	21.5	MC
11 meters	-	26.5	-	27.5	MC
10 meters	-	28.0	-	29.0	MC
				29.0	- 30.0 MC

The first conversion circuit, consisting of a crystal controlled oscillator, V-4 and a mixer tube, V-3, converts the incoming signal to the variable IF frequency of 2.5 to 1.5 MC for all bands from 80 meters thru 10 meters. The variable IF is mixed with a signal from the VFO, V-14 and V-15, in the second mixer V-5 where it is converted to a fixed IF of 455 KC. See figure 5-7. A discussion of the individual circuits in the RF portion of the receiver follows:

a. RF STAGE. The RF stage uses a 6DC6 pentode. This tube was chosen because of its low-noise, remote-cutoff characteristics. This tube allows greater grid voltage swing without cross-modulation distortion. Individual variable slug-tuned coils are switched into the grid circuit on 160 and 80 meters. On 40-10 meters the coil in use is switched across the 80-meter coil, and varying the inductance of the 80-meter coil tunes the coil for the band in use. The 80-meter trimmer capacitors are not in the circuit on 40-10 meters.

One coil, T-7, is used for the 11 and 10-meter bands. Manual tracking is used here employing the ANT TRIM capacitor, C-18. Separate antenna coils are employed on the 10-11-meter coil, the 80-meter coil, and the 160-meter coil.

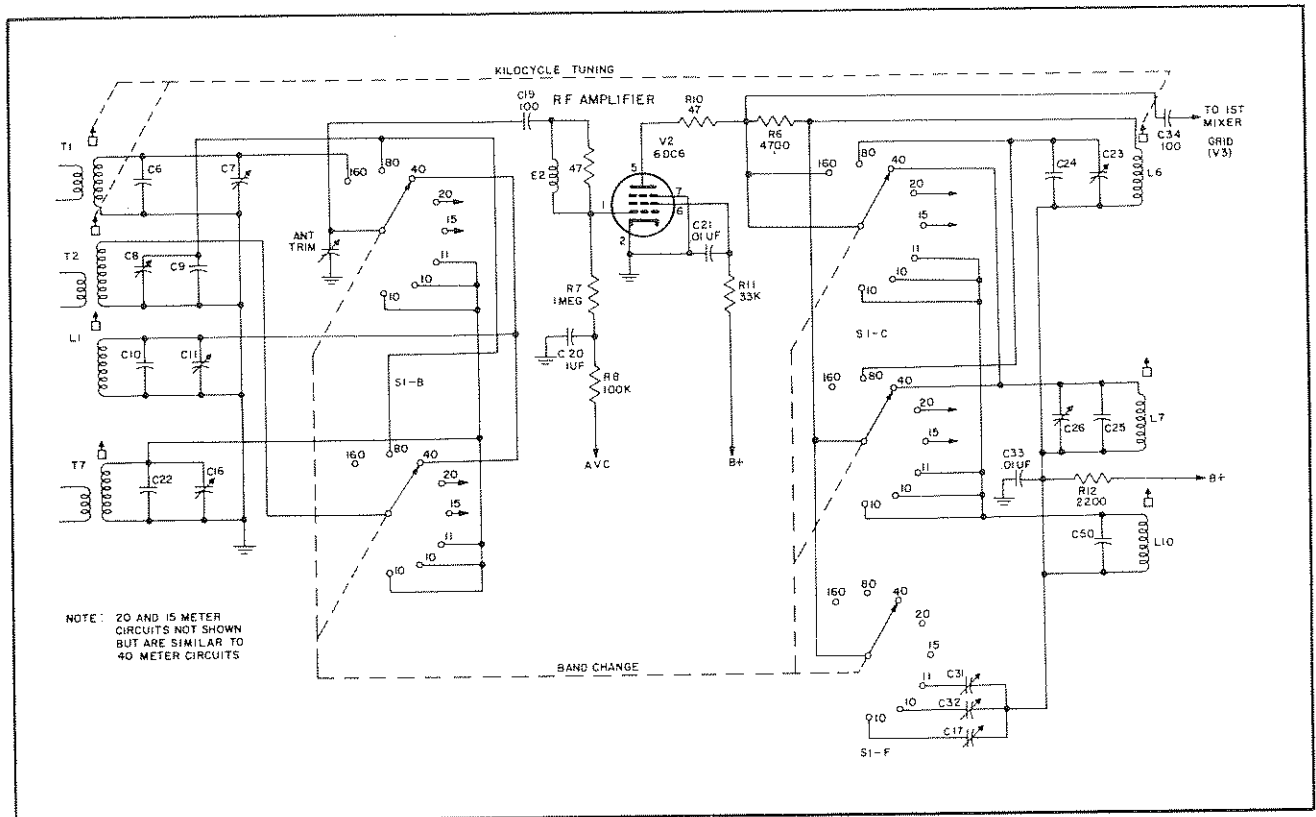

Figure 4-1. Tuning Elements of RF and Mixer Stages, Simplified Diagram

The 160-meter band feeds on thru the first mixer, V-3, into the 2.5 to 1.5 MC variable IF coils, which track with the receiver front end, and on into the second mixer V-5. On 80, 40, 20, 15 and the highest frequency 10-meter band the first mixer grid circuit is similar to the RF stage grid circuit with the higher frequency coils being

paralleled with the 80-meter coil to produce the tuning for the band in use. On the low 10-meter band and the 11-meter band, capacitors C-32 and C-31 are individually selected to pad the 10-meter coil to these bands. The following table shows the tuning components used in the various bands for each tube circuit.

BAND (METERS)	ANT L	ANT C PAD	ANT C TRIM	RF L	RF C PAD	RF C TRIM	OSC L	OSC PAD
160	T-1	C-6	C-7 C-18	-	-	-	-	-
80	T-2	C-9	C-8 C-18	L-6	C-24	C-23	L-12	C-40
40	L-1 (T-2)	C-10	C-11 (C-18)	L-7 (L-6)	C-25	C-26	L-13	C-41
20	L-2 (T-2)	C-12	C-13 (C-18)	L-8 (L-6)	C-27	C-28	L-14	C-42
15	L-3 (T-2)	C-14	C-15 (C-18)	L-9 (L-6)	C-29	C-30	L-15	C-43
11	T-7 (T-2)	C-22	C-16 (C-18)	L-10 (L-6)	C-50	C-31	L-16	C-44
10 LO	T-7 (T-2)	C-22	C-16 (C-18)	(L-10) (L-6)	C-50	C-32	L-17	C-45
10 HI	T-7 (T-2)	C-22	C-16 (C-18)	(L-10) (L-6)	C-50	C-17	L-11	C-51

() Components used in a previous band

b. CRYSTAL CONTROLLED OSCILLATOR AND FIRST MIXER.

The high frequency mixer stage employs a 12AT7 (V-4) in a crystal controlled oscillator circuit to provide a heterodyning signal. In this oscillator circuit the crystal is connected between the cathodes of a dual triode. One section (V-4 pins 6, 7, 8) is a cathode follower amplifier, the other section, a grounded grid amplifier. Feedback voltage is coupled from the plate of one section, which contains a tank circuit resonant at the crystal frequency, to the grid of the other section. The crystal, inserted between the cathodes, acts as a filter. The phase change through the loop is zero and oscillation takes place at the crystal frequency. Crystal oscillator output voltage is coupled to the injection grid of the 6BA7 first mixer. An individual crystal for each band is switched into the crystal oscillator circuit except for 160 meters, where the high frequency oscillator is not used. The crystal oscillator beats with the incoming carrier to produce the first, or variable, intermediate frequency. In this stage, because the crystal frequency is fixed and the incoming carrier frequency may be anywhere in the range of the band in use, the difference frequency produced in the mixer must be tuned by a variable IF system.

c. VARIABLE IF. The variable IF covers the range 2.5 to 1.5 MC. The system consists of two slug-tuned coils on the same frequency. The first of these coils is capacity coupled to the second which in turn is connected to the grid of the second mixer V-5. L-23, a 5.7 MC trap is connected between the two coils to remove a spurious response that occurs at 3.533 MC.

d. VFO AND SECOND MIXER. A Type 70E-24 permeability-tuned precision variable frequency oscillator provides the injection voltage to the second mixer V-5. The frequency range of the VFO is 1955 KC to 2955 KC. This frequency is mixed with the variable IF in V-5 to produce the fixed 455 KC difference frequency which is the frequency of the fixed IF amplifier.

e. MECHANICAL FILTER. The functional diagram of the Collins Mechanical Filter is shown in figure 4-2. The mechanical filter uses the principle of magnetostriction to convert electrical energy to mechanical vibration. The magnetostriction transducer input coil is resonated at 455 KC. A nickel wire within this coil vibrates mechanically and transmits this mechanical energy to the first of a series of nickel alloy discs. The mechanical vibration of this first disc is coupled to succeeding

discs by means of nickel-wire coupling elements. Biasing magnets at either end of the mechanical filter polarize the filter elements to prevent frequency doubling, in much the same manner as biasing magnets in a headphone prevent the headphone diaphragm from bending in the same direction for both halves of an AC cycle. The mechanical vibration of the last disc is coupled to a magnetostriction transducer element identical to the one used at the input of the filter. By a reverse principle of magnetostriction, the mechanical vibration of the nickel-wire transducer core is converted to electrical energy.

Each of the discs employed in the mechanical filter has a mechanically resonant Q exceeding 2,000. Six of these discs are overcoupled to produce a mechanically-shaped response curve with a flat top and straight, almost vertical sides. Thus, the filter passes a band of frequencies very little wider than the flat top of the selectivity curve. The mechanical filter furnished with the 75A-4 passes a band of frequencies approximately 3 KC wide and centered on 455 KC, providing an IF selectivity curve ideal for the reception of AM and single-sideband signals. The 3-KC filter is supplied as part of the 75A-4; however, a mechanical filter having similar selectivity characteristics but having a band pass of 500 cycles is available for use in CW reception. A 6-KC filter is available for double-sideband reception of AM.

The mechanical filters used in the 75A-4 are the plug-in type that plug into a 9 pin miniature tube socket. These are sealed units and must not be tampered with. No external variable tuning is employed.

f. "Q" MULTIPLIER. (See figure 5-5.) The "Q" multiplier, as used in the 75A-4, is employed only as a rejection filter. In this capacity it performs the same function as the rejection notch of the crystal filter in earlier receivers but does it much better. It is capable of attenuating as much as 40 db, any single audio tone (heterodyne) which may be present within the receiver's passband. The "Q" multiplier consists of a cathode follower amplifier coupled to a regenerative amplifier, the plate load of which is a bridge T-filter. The regenerative amplifier is kept just below the oscillating point by R-36. At this point the plate circuit has a very high Q and provides a very sharp null to frequencies within the receiver passband. REJECTION TUNING capacitor C-72 can shift the null around to any frequency within the passband. The "Q" multiplier is removed from the circuit by turning the

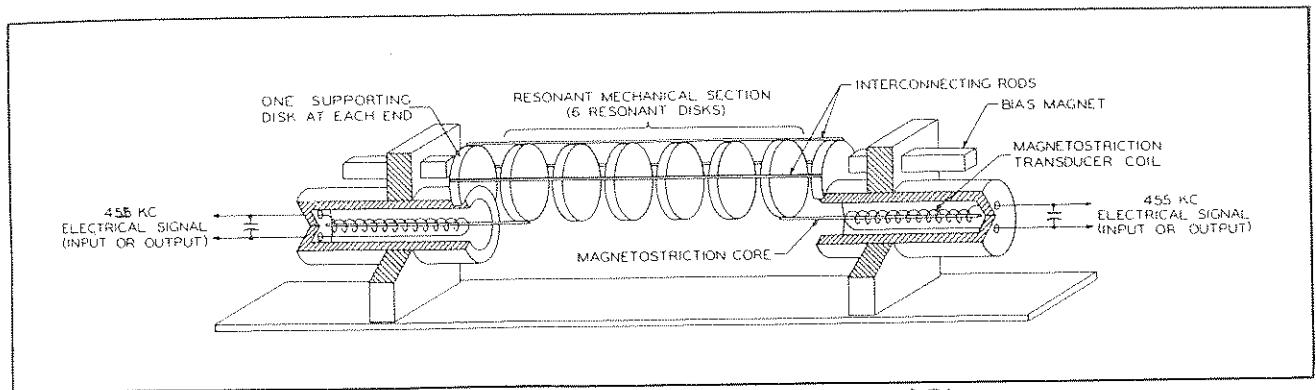

Figure 4-2. A Collins Mechanical Filter, Functional Diagram

REJECTION TUNING Control clockwise to actuate a switch which short circuits inductor L-26.

g. 455 KC IF. AMPLIFIER. The 455 KC IF amplifier consists of V-6 which is associated with the mechanical filter and V-8 and V-9; the latter two are conventional IF amplifiers that contribute nothing to the passband wave shape, which is determined by the mechanical filter. All are 6BA6 tubes. AVC is applied to the grids of all three tubes.

h. AM DETECTOR. The AM detector is a conventional diode rectifier excited from IF transformer T-3 and having R-56 and R-57 as its load. The audio from the detector is applied to the noise limiter, V-12, when AM CW SSB selector switch S-3 is operated to AM position.

i. CW-SSB DETECTOR. This detector, V-11 is designed especially for SSB reception. It is a mixer type circuit that takes the output of the BFO and mixes it with the output of the 455 KC IF. Tube elements 1, 2 and 3 perform as a cathode follower amplifier. The remainder of the tube is a plate detector, the cathode of which is common with the cathode follower amplifier. The detector greatly reduces the distortion which is generated when a conventional diode detector is used for detecting SSSC signals. The audio from the detector is applied to the noise limiter V-12 when S-3 is operated to the CW-SSB position.

j. BFO. The BFO V-20, uses a 6BA6 in an electron coupled oscillator whose frequency range is approximately 453-457 KC. The BFO is tuned by means of the knob on the front panel labeled PASSBAND TUNING. The shaft of the PASSBAND TUNING Control is attached by a metal belt to the frame of the variable frequency oscillator which is mounted in a ball and oilite bearing equipped cradle. As the BFO is tuned through its range the VFO is also

tuned a like amount. (The shaft of the VFO is prevented from turning by the gearing of the vernier tuning dial.) Because the actual intermediate frequency is changing, the passband is being shifted and an unwanted signal can be dropped off the edge of the passband while retaining the wanted signal in the passband without changing its pitch.

4. AUDIO CIRCUITS.

a. NOISE LIMITER. Noise limiter V-12, a 6AL5 tube, couples the audio from the detectors to the first audio stage. The function of the noise limiter is to minimize interference by removing noise peaks which exceed the amplitude of the modulation. It is effective on AM, CW and SSB.

Both diode sections of the 6AL5 are required in order to limit both the positive and the negative peaks. During AM reception, a negative voltage is derived across diode load resistors R-56 and R-57. NOISE LIMITER Control R-67 is connected to this source of supply. As a result the cathodes of V-12 assume a negative DC potential which is adjustable by means of the NOISE LIMITER Control, and direct current flows through the diodes (the plates being positive with respect to the cathodes). The AF signal voltage from the receiver is applied to the anode (pin 7) of one section of V-12 through coupling capacitor C-93. This AF signal modulates the DC flowing through this diode section and, as a result, the AF signal appears across cathode resistor R-65. This resistor is common to both diode circuits, therefore the AF signal is superimposed on the DC flowing through the second section of V-12 and appears across load resistor R-63. From this point, the signal is coupled through C-96 and AF GAIN Control R-62 to the audio amplifiers.

Any negative impulse that drives the anode of the input diode (pin 7) more negative than the cathode, will cut off the diode, and that impulse will be

Section IV
THEORY OF OPERATION

limited to an amplitude equal to the threshold voltage (as set by the NOISE LIMITER Control). Similarly, any positive impulse that overcomes the threshold potential on the cathode of the second section (pin 5) will cut off that diode, and the positive impulse will be limited. As the NOISE LIMITER Control is turned toward 10 a less negative threshold voltage is applied to the diodes, and more severe limiting results. The threshold voltage at any given setting of the NOISE LIMITER Control varies with the average amplitude of the diode load signal, therefore limiting action automatically adjusts itself. C-97 and R-66 decouple the limiter circuit from the detector circuit.

During CW or SSB reception when the carrier is intermittent or absent, the reference voltage is supplied by connecting the NOISE LIMITER Control R-67 through switch S-3 to a value of bias obtained from the receiver bias rectifier. Because of the flat AVC characteristic of the receiver, frequent adjustment of the NOISE LIMITER Control is unnecessary.

The noise limiter is made inoperative by applying a value of B+ to the diode plates through R-64 and by grounding the cathodes of V-12 thus insuring that the diode currents cannot be cut off on noise or high modulation peaks. This is done by a switch associated with the NOISE LIMITER Control. C-98 provides a ground path for the audio when S-4 is in the OFF position.

b. AUDIO AMPLIFIERS. The audio section consists of two stages of voltage amplification (both halves of the dual triode V-13, a 12AT7) and a 6AQ5 power amplifier. The AF GAIN Control is located in the grid circuit of the first stage. Fixed bias from the bias rectifier is applied to the grid of the power amplifier. The output transformer secondary consists of a 500-ohm winding suitable for driving auxiliary apparatus and a four-ohm winding for use with loudspeaker voice coil and headphones. When a headphone is plugged into the headphone jack J-2, the speaker connection is interrupted and a 10-ohm load resistor is connected in parallel with the headphone to keep the output transformer properly loaded.

5. RF GAIN CONTROL SYSTEM.

The RF gain control system in the 75A-4 works in conjunction with the AVC system. To control the sensitivity of the set, a source of fixed bias is added to the AVC voltage which is then applied to the AVC controlled tubes. This system maintains the gain distribution constant throughout all settings of the gain control. In order to prevent the RF GAIN Control from affecting the characteristics of the line due to loading, an RF gain gate is employed to decouple the RF GAIN Control from the AVC line. This gate is in the form of 1/2 of a type 6AL5 twin diode, V19.

The other half of the tube is employed as a bias rectifier.

Bias from this rectifier is connected to one end of the RF GAIN Control. The arm of the control is connected to the AVC line through the RF gain gate, V19 (pins 1 and 7). Advancing the control adds negative bias to the AVC bias and reduces the gain of the tubes connected to the AVC line, namely, V-2, V-6, V-8, and V-9. The value of R104 is selected in final test and ranges from 180 ohms to 560 ohms. R104 in this set will be one of the following values and part numbers:

180 ohms	745 1321 00
220 ohms	745 1324 00
270 ohms	745 1328 00
330 ohms	745 1331 00
390 ohms	745 1335 00
470 ohms	745 1338 00

6. "S" METER.

The "S" meter is connected in a bridge circuit between the cathode of V-8 and the screen grids of V-6 and V-8. These are the I-F amplifier tubes that are furnished with AVC voltage. A reference voltage is developed at the positive terminal of the "S" meter by the screen current flow of V-6 and V-8. This reference voltage is adjusted by R-43 under no-signal conditions to a value equal to that developed at the negative terminal of the "S" meter by the cathode current of V-8. The presence of a signal in the IF strip causes an AVC voltage to be developed which reduces the current through V-8 causing its cathode voltage to decrease and at the same time causing the screen voltage on the two IF tubes to slightly increase. These changes of voltages at the cathode of V-8 and at the screen circuits of the two IF tubes, being in opposite directions, unbalance the bridge and cause the meter to read in proportion to the strength of the received signal. R41 adjusts the sensitivity of the "S" meter.

7. AVC SYSTEM.

A low impedance AVC line is employed to minimize blocking on strong signals. The RF amplifier V-2 and the 455 KC IF amplifiers V-6, V-8, and V-9 are all AVC controlled. A stage of IF amplification V-21, separate from the signal IF amplifier, is employed to amplify the IF signal for rectification for AVC voltage. The IF amplified IF voltage is rectified by 1/2 of V-16, a twin diode. The other half of V-16 is used as an AVC noise clipper. This tube clips sharp noise impulses from the AVC voltage and thus prevents the noise from desensitizing the AVC Circuit. A small positive DC voltage is applied to the AVC rectifier through R-86 to produce an AVC delay so that the AVC is ineffective on weak signals. A network of load resistors is switched by switch S-5 to select either fast or

slow AVC characteristics. C-110 provides RF filtering for the AVC detector output, R-89, R-91 and R-92 are the detector loads. R-90 and C-112 provide the AVC time constant with R-92 and R-91 modifying the time constant for slow and fast AVC operation. AVC test point J-4 is provided for use in aligning the AVC IF amplifier transformer T-4. Each controlled stage is decoupled from the AVC line by suitable capacitors and resistors to prevent instability because of RF feedback.

8. CALIBRATOR CIRCUIT.

The calibrator employs a 6BA6 tube in a crystal controlled oscillator circuit. The fundamental frequency of the oscillator is 100 KC, therefore, a harmonic appears at each 100 KC point over the entire range of the receiver when the calibrator is turned on. C-1 is used to zero beat a calibrator harmonic with a 1500 KC or 1600 KC broadcast station or with WWV at 2.5, 15 or 30 MC. The calibrator output is coupled to the receiver input by C-5. The calibrator is turned on wherever S-6 is in the CAL position.

SECTION V MAINTENANCE

1. TROUBLE SHOOTING.

The table of voltage measurements located at the end of the alignment procedure will help in locating troubles which might arise in the 75A-4. Most normal receiver troubles such as burned-out tubes,

loose connections, noisy volume controls etc., are easily discovered and remedied. However, should more obscure troubles arise, only a trained and competent repairman should be allowed to service the receiver. The following table gives a few possible causes for failure that might be associated with tubes having unusual functions.

TUBE	FUNCTION	SYMPTOM	CAUSE AND REMEDY
V-7	"Q" Mult.	Insufficient rejection notch. Notch not centered on dial when signal is centered in passband.	Realign L-26 and L-36 per part 6. Set panel control to midscale and adjust L-26 for notch.
V-10	MUTING DIODE	Insufficient muting.	Check muting voltage; should be +20 volts for 40 db muting.
V-11	SSB-CW DET	Hum level high.	Heater-cathode leakage in V-11 or V-20. Replace tube.
V-12	NOISE LIMITER	Excessive hum.	Heater cathode leakage in V-12. Try new tube.
V-21	AVC AMPLR	Insufficient AVC.	Bad tube or misalignment of T-4. Leaky AVC by-pass.
V-19	BIAS RECTIFIER	Excessive distortion.	Low bias voltage. Try new tube.

2. FUSE.

The 75A-4 is supplied with a 2 ampere fuse. If the fuse blows, do not replace it until the trouble has been determined and remedied. Use only a type 3AG Slo-Blo fuse of 2 ampere capacity.

3. TEST EQUIPMENT REQUIRED FOR 75A-4 ALIGNMENT.

- a. Signal generator.
- b. Vacuum tube voltmeter.

4. PRELIMINARY CHECKS.

- a. 2 ampere fuse in holder.
- b. Output voltage of power supply at approximately 170-V. (Measure at C-94B to ground.) Unless specifically changed in the following procedures, keep the following controls in the positions noted:

PASSBAND TUNING to 0

NOISE LIMITER to OFF

REJECTION TUNING to 0

SELECTIVITY to 3 KC FILTER

OFF-STANDBY-ON CAL to ON

5. 455 KC IF ALIGNMENT.

- a. Set the REJECTION TUNING Control to OFF, RF GAIN to maximum, the AM CW-SSB switch to AM, the AVC switch to FAST and the OFF-STANDBY-ON CAL switch to ON.
- b. Connect the lead from the signal generator to pin 1 of V-9, and tune the signal generator to 455 KC.
- c. Connect the VTVM to the AVC TEST POINT.
- d. Increase the signal generator level until an increase above the static level is noted on the VTVM.
- e. Adjust tuning cores of T-4 for a maximum indication on the VTVM.
- f. Connect VTVM to DIODE LOAD TEST POINT and set AVC switch to OFF.
- g. Adjust tuning cores of T-3 for a maximum indication on the VTVM.
- h. Connect signal generator to pin 1 of V-8.
- i. Adjust L-27 for maximum indication on VTVM.

6. REJECTION TUNING ALIGNMENT.

- a. Tune in 1800 kc calibration signal with KILOCYCLES dial to exact center of passband by watching "S" meter.
- *b. Adjust ANT TRIM until an "S" meter reading of exactly S9+40 is obtained.
- c. Turn R-36 to full counterclockwise position.
- d. Turn REJECTION TUNING Control (C-72) to center of passband.
- e. Adjust L-26 for minimum "S" meter reading
- f. Turn R-36 clockwise until an S meter reading of S-7 is obtained.
- g. Recheck steps d. and e., readjust where necessary.

If difficulty in the final adjustment of L-26 is encountered, the REJECTION TUNING Control may be moved slightly to compensate for small errors in L-26.

A rejection notch which is deeper than S-7 may be obtained with a higher setting of R-36. This is not advisable, however, because of the resulting instability such as hum modulation and a tendency for the "Q" multiplier circuit to lock to a strong interfering signal.

*If it is not possible to adjust to exactly S-9+40, use S-9+20 and set R-36 so "S" meter reads "O" at null.

The effect is quite similar to that obtained by operating a regenerative receiver too near to the edge of oscillation.

As R-36 is advanced even further clockwise, the "Q" multiplier circuit will oscillate. This causes the depth of the rejection notch to decrease sharply as R-36 is rotated through the point where oscillation begins.

7. BFO ALIGNMENT.

There are several conditions that might cause a need for resetting the BFO to frequency.

The first is where a slight drift of frequency produces a need for resetting the BFO to frequency.

The second is where the front panel has been removed and where the BFO knob (BANDPASS TUNING) has been removed from the shaft.

The third condition is where the BFO coil assembly has been replaced and a tracking problem exists.

a. SIMPLE ALIGNMENT. Where simple alignment of BFO frequency is concerned:

- (1) Turn REJECTION TUNING to OFF, set AM CW-SSB to AM. Select 3-KC filter. Select FAST AVC.
- (2) Set OFF-STANDBY-ON CAL switch to CAL.
- (3) Tune in a calibration signal with KILOCYCLES DIAL to exact center of passband by watching "S" meter.
- (4) Set PASSBAND TUNING to 0. Set AM-CW SSB to CW SSB.
- (5) Remove plug from top of BFO can and adjust inductance slug for zero beat.

b. Where the front panel or BANDPASS TUNING knob has been removed and the calibration of the BANDPASS TUNING knob has been lost:

- (1) If the tracking between the VFO and the BFO has not been disturbed, merely set the VFO frame so that the tubes are straight up, tune in a CAL signal to zero beat and put the BANDPASS TUNING knob on shaft with the marker on zero. Tighten the setscrews.
- (2) If the tracking between the VFO and BFO has been disturbed, (BFO shaft out of track at the flexible coupler or at the metal belt pulley) see the paragraphs below.

c. Where the BFO coil assembly has been replaced and complete tracking is necessary:

- (1) The new BFO coil is very nearly aligned when it is purchased i. e., the trimmer capacitor and coil slug are set to produce 455 KC at the correct position in the pitch control capacitor C-117 and a blue dot is painted at the root of the shaft of C-117 to use in initially positioning C-117.

Section V
MAINTENANCE

(2) After the BFO coil is properly connected, connect up the metal belt but allow the pulley to remain free on the BFO shaft.

(3) Set the VFO frame with the tubes straight up and tune in a CAL signal to dead center on the KILOCYCLES dial and set the DIAL SET to 0.

(4) Turn the AM CW-SSB Control to CW-SSB and turn the BFO shaft to zero beat with the blue dot upward.

(5) Set the PASSBAND knob to zero and tighten its setscrews.

(6) Tighten the setscrews in the pulley.

(7) Turn the PASSBAND TUNING Control through its range and see if the BFO tone stays at reasonably close to zero beat throughout the range. If an error of over 50 cps is experienced, the BFO can be retracked as follows:

NOTE

Because the following procedure is difficult do not attempt it unless the BFO tracking error is really objectionable.

(9) Use 6 KC filter, setup for CW operation, tune PASSBAND TUNING to 0 and tune in a CAL signal to zero beat with KILOCYCLES dial on the 160-meter band.

(10) Peer down in the BFO can and note the positions of the two trimmer adjustment slots. Make a drawing if necessary.

(11) Turn the inductance trimmer (L-31) 10 degrees or so clockwise.

(12) Return to zero beat by turning the trimmer capacitor C-118.

(13) Now offset the KILOCYCLES dial on the low frequency side of 0 until a very low frequency tone is produced.

(14) Tune the PASSBAND TUNING Control through its range and see if the tone error is any better. (The change will be only in the order of a few cps so frequency measuring equipment should be used if available.)

(15) If the results are favorable return the KILOCYCLE dial to zero beat and repeat steps 11 through 14.

(16) If the error is greater, return the trimmers (L-31 and C-118) to their original positions and repeat steps 12 through 14 except turn the inductance trimmer L-31 in the other, or counterclockwise, direction.

(17) Repeat the alignment procedure until no better results can be obtained. The error should now be less than 50 cps.

NOTE

An error produced by backlash is possible. This error must not be included when checking for alignment, therefore when the end stops of the PASSBAND TUNING knob are reached, back up the knob very slightly to take up the backlash.

NOTE

It should be possible to swing the BAND-PASS TUNING knob 2.5 KC each side of center without being stopped either by the VFO frame hitting the chassis or by the BFO shaft end stops. If either of these occur, reset the BFO end stops and BAND-PASS TUNING knob as required and reset the BFO frequency to zero beat with L-31.

8. VARIABLE IF AND 160-METER BAND ALIGNMENT.

a. Connect signal generator to antenna input through a 100-ohm dummy antenna, and connect VTVM to DIODE LOAD test point.

b. Connect audio output meter to audio terminals 500 and G and rear of receiver.

c. Set AM CW-SSB switch to AM, AUDIO GAIN to maximum, and RF GAIN to maximum. Select 3 KC mechanical filter.

d. Set receiver dial and signal generator to 1.6 MC, and adjust tuning slugs L-18, L-22, and T-1 for maximum output indication.

e. Set receiver dial and signal generator to 2.4 MC, and adjust capacitor C-7, C-53, and C-56 for maximum output.

f. Repeat steps d. and e. until no further increase is noted in output.

9. ALIGNMENT OF CRYSTAL OSCILLATOR.

- a. Connect VTVM through a 1 megohm resistor to pin 2 of V-3. Turn AM CW-SSB to AM.
- b. Set BAND switch to 80 and adjust L-12 for maximum output indication.
- c. Successively change BAND switch to 40, 20, 15, 11, 10, 10 and adjust L-13, L-14, L-15, L-16, L-17, and L-11 in that order for a maximum output indication. Adjust L-13 core one-quarter turn into coil from peaked position.
- d. The frequency of the crystals may be adjusted over a limited range by the adjustments of steps b. and c. After other alignment operations are completed, this method may be used to reduce the calibration error between bands.
- e. Turn on the CAL oscillator (100 KC crystal standard) being sure it is on frequency. (See part 5 of section II for adjustment), and tune the receiver to zero beat at exactly 2.0 MC.

NOTE

Do not turn tuning dial or PASSBAND TUNING during the remainder of this adjustment.

f. Turn BAND switch successively to the remaining bands, and adjust the receiver to zero beat by repeating steps b. and c. Be sure that the crystal oscillator does not stop oscillating or does not start oscillating at a spurious frequency.

10. RF ALIGNMENT.

- a. Connect signal generator to antenna terminals on receiver, and VTVM to DIODE LOAD test point.
- b. Rotate BAND switch to 160, and tune signal generator and receiver to 1.6 MC.
- c. Adjust tuning core in T-1 for maximum diode load voltage.

NOTE

ANT TRIM shall be set to half capacity while aligning all bands.

d. Tune the signal generator and receiver to 2.4 MC, and adjust capacitor C-7 for maximum diode load voltage.

e. Repeat steps c. and d. until no further increase in output is noted. If the 160-meter coil was aligned along with the 1.5 to 2.5 MC IF, disregard the above and proceed with the remainder of the bands.

f. Repeat steps c., d., and e. for the other bands using the following table as a guide.

BAND	RECEIVER AND SIG. GEN. FREQ. LOW END	RF "L"	ANT "L"	RECEIVER AND SIG. GEN. FREQ. HIGH END	RF "C"	ANT "C"
160	1.6	-	T-1	2.4	-	C-7
80	3.3	L-6	T-2	4.1	C-23	C-8
40	6.9	L-7	L-1	7.7	C-26	C-11
20	14.1	L-8	L-2	14.9	C-28	C-13
15	20.6	L-9	L-3	21.4	C-30	C-15
*11	27.1	-	-	-	C-31	-
*10	28.1	L-10	T-7	28.9	C-32	C-16
*10	29.5	-	-	-	C-17	-

*In performing the alignment of the 11 and the two 10-meter bands, a specific sequence is necessary. First, align the 28 to 29 MC band in the normal manner with the ANT TRIM at midscale. The 26.5 to 27.5 MC band and the 29 to 30 MC bands are aligned at one point only by RF trimmers, C-31 and C-17. It is necessary to retune the ANT TRIM for resonance on these bands since no alignment trimmers are provided in the antenna circuit. Any retuning of L-10 after alignment will affect the tracking of bands 11, 10 and 10.

11. VFO ADJUSTMENT.

The VFO is calibrated at the factory and should require adjustment at only widely separated intervals. If the calibration error becomes excessive for operation or beyond the point where the vernier dial corrector (ZERO SET Control) can correct, the following procedure should be followed to make correcting adjustments:

- a. Use the 100 KC/s calibrator. Allow the receiver to warm up from 1 to 2 hours.
- b. Set the BAND CHANGE switch to the 160-meter band. Tune KILOCYCLES dial to 1.5 MC/s. Set up in accordance with paragraph 9 of OPERATION section to zero beat with calibrator signal. Note the dial reading if fiducial line cannot be set to 0.
- c. Rotate KILOCYCLES dial to 2.5 MC/s and exactly tune until zero beat is obtained. Do not re-adjust BFO or ZERO SET Control. The calibration error is then the number of dial divisions more or less than the 10 turns it should take to cover the range. Usually, the error tends to be toward more rotation of the KILOCYCLES dial than the 10 turns that should be required. To correct this error, proceed as follows:

- (1) Rotate the KILOCYCLES dial towards and through dial zero until a total of 1.8 times the dial division error has been counted. Engage the trimmer adjusting stud with a strong thin wire and turn until zero beat is restored. The ZERO SET adjustment can now be rotated so that the ZERO SET is set to dial zero.

- (2) To check the accuracy of the adjustment retune the KILOCYCLES dial to 1.5 MC/s and check the calibration error. If the adjustments have been done carefully less than 1/2 division dial error will be found. The above procedure can be repeated until satisfactory results are obtained. This endpoint adjustment restores factory accuracy to the intermediate points, also.

- (3) If it is desired to recenter the dial vernier pointer the following additional procedure should be followed. Set the ZERO SET Control to midscale, loosen the two setscrews of the VFO dial-shaft coupler and carefully turn the oscillator shaft until zero beat is obtained. During the VFO adjustment, best results in frequency readings will be obtained if the AVC is OFF and the RF GAIN Control is used at a low value.

12. TWEET TRAP ADJUSTMENT.

- a. A third order tweet appears at 3.533 MC in the 80-meter band caused by the 5.7 crystal beating with the second harmonic of the VFO at the mixer V-5.

- b. Turn the AM CW-SSB switch to CW-SSB and tune in the tweet.

- c. Adjust the core of L-23 until the level of tweet is minimum.

13. AVC THRESHOLD (R-9).

- a. Connect VTVM to AVC test point and ground and set range switch to 5-volt range.

- b. Set RF GAIN to maximum. Select FAST AVC.

- c. Feed a 29.5 MC signal from a signal generator into the antenna terminals using a 100-ohm resistor in series with the signal generator.

- d. Tune in the signal "on the nose".

- e. Increase the input signal until a definite increase in AVC voltage is noted and record the input.

- f. Adjust R-9 so that the AVC threshold occurs with 3 uv input.

14. DIAL CORDS.

The front panel must be removed for replacement of the dial pointer cord or the drum rotator cord. Figure 5-1 shows both cords in place and the direction in which the restringing should proceed.

- a. REMOVING FRONT PANEL. (See figure 5-4).

- (1) Remove the six panel screws.

- (2) Remove the following knobs:

REJECTION TUNING

SELECTIVITY

PASSBAND TUNING (see CAUTION below)

ANT TRIM

BAND CHANGE

KILOCYCLES TUNING

CAUTION

Set the PASSBAND TUNING Control knob on the index mark (straight up) and do not move the control after the knob has been removed. If the control has been accidentally moved, see part 7 for instructions for adjusting the knob position.

b. POINTER CORD. Obtain a type 432 1018 00 Collins Dial Cord.

(1) Scribe a mark on the VFO shaft and the KILOCYCLES dial hub to mark their relative positions and remove the KILOCYCLES dial.

(2) Turn the tuning knob to the clockwise stop.

(3) Start at point X in the drawing with the cord hooked to one end of the spring (part number of spring is 503 1240 001).

(4) Bring cord around pulley C to pulley B.

(5) Wrap around pulley B clockwise, through the deep slot, around the tab, and back through the shallow slot. Wrap around pulley B two times clockwise.

(6) Wrap cord around pulley A and loop the end on the free end of the spring.

(7) Fasten the pointer to the cord, tune in a station of known frequency and adjust the pointer to the correct setting.

(8) Replace the KILOCYCLES tuning dial. Match up the scribe marks (see step (1)) and tighten setscrews.

(9) Replace the panel.

c. DRUM CORD. Obtain a 432 1020 00 Collins Dial Cord.

(1) Turn the band switch to the 1.5 - 2.5 MC band (pulley D at counterclockwise stop).

(2) Turn pulley E approximately one turn and hold the tension spring taut.

(3) Make approximately 3/4 turn around pulley D and hook cord to tab.

(4) Extend the cord around pulley E and hook to the tab. Release the tension spring.

(5) Replace the panel.

(6) Loosen the setscrew in the drum hub opposite the coil tension spring, and align the dial calibration to the 1.5 - 2.5 MC band. Then tighten the setscrew.

TABLE 5-1. VOLTAGE AND RESISTANCE MEASUREMENTS

		Pin Number									
TUBE		1	2	3	4	5	6	7	8	9	PLATE CAP
V-1	DC V.	-22.5	7.5			88	64	8			
	AC V.			0	6.3						
	Ohms	680K	4700	0		00	140K	4700			
V-2	DC V.	-5.7	0			190	175	0			
	AC V.			0	6.3						
	Ohms	1.5 meg	0	0		20K	50K*	0			
V-3	DC V.	140	-2.7	2.3			0	0	0	190	
	AC V.				6.3						
	Ohms	22K	25K	120		0	0	510K	0	21K	
V-4	DC V.	175	0	1.5			175	-2.6	1.8		
	AC V.				0	0				6.3	
	Ohms	21K	0	330	0	0	21K	10.5K	330		
V-5	DC V.	105	-3.8	1			0	0	0	190	
	AC V.				6.3						
	Ohms	27K	100K	68		0	0	0	0	21K	

Section V
 MAINTENANCE

TABLE 5-1. VOLTAGE, AND RESISTANCE MEASUREMENTS (Cont.)

TUBE		Pin Number									PLATE CAP
		1	2	3	4	5	6	7	8	9	
V-6	DC V.	-2.8	0			190	100	*4			
	AC V. Ohms	1.8 meg	0	0	6.3	20K	35K	*2.6K			
V-7	DC V.	185	0	2.3			185	0	2.3		
	AC V. Ohms	21K	100K	470	0	0	20K	330K	470	6.3	
V-8	DC V.	-5.7	0			190	95	0.65			
	AC V. Ohms	1.4 meg	0	0	6.3	22K	36K	220			
V-9	DC V.	-.7	0			185	85	1.2			
	AC V. Ohms	420K	0	0	6.3	22K	68K	150			
V-10	DC V.	1.4	0			.85	0	0			
	AC V. Ohms	3.3K	70K	0	6.3	00	00	00			
V-11	DC V.	140	0	3.6			84	0	3.6	0	
	AC V. Ohms	33K	100K	820	0	0	75K	100K	820	6.3	
V-12	DC V.	*** -13.5	*** -13.5			*** -13.5	0	*** -13.2			
	AC V. Ohms	400K	470K	0	4.3	** 400K	00	250K			
V-13	DC V.	69	0	1.5			75	0	1.4	0	
	AC V. Ohms	240K	68K	3.3K	0	0	240K	510K	3.3K	6.3	
V-14	DC V. AC V. Ohms										
V-15	DC V. AC V. Ohms										
V-16	DC V.	0.1	0.1			15	0	-.5			
	AC V. Ohms	340K	340K	0	6.3	3.3K	00	2.2 meg			
V-17	DC V. AC V. Ohms	00	22K	00	68	00	72	00	22K		

TABLE 5-1. VOLTAGE, AND RESISTANCE MEASUREMENTS (Cont.)

TUBE		Pin Number									PLATE CAP
		1	2	3	4	5	6	7	8	9	
V-18	DC V.	0	0	0	0	160	0	0			
	AC V.										
	Ohms	00	0	00	00	23K	00	00			
V-19	DC V.		-135				0				
	AC V.			0	6.3	120AC					
	Ohms		30K	0		0	00				
V-20	DC V.	-5	0		0	14	42.5	0			
	AC V.			6.3	0						
	Ohms	150K	0		0	10K	00	0			
V-21	DC V.	0	0			185	75	1.3			
	AC V.			0	6.3						
	Ohms	1 meg	0	0		22K	82K	150			
V-22	DC V.	-11	0			220	205	-11			
	AC V.			0	6.3						
	Ohms	168K	0	0		21K	20K	168K			

NOTES:

1. AVC in OFF position.
2. Unless otherwise indicated RF GAIN adjusted until "S" meter needle rests at S-9 with no signal input.

* Depends upon setting of R-9.

** Depends upon setting of R-67.

*** AM CW-SSB at CW-SSB; NOISE LIMITER (R-67) at 1.

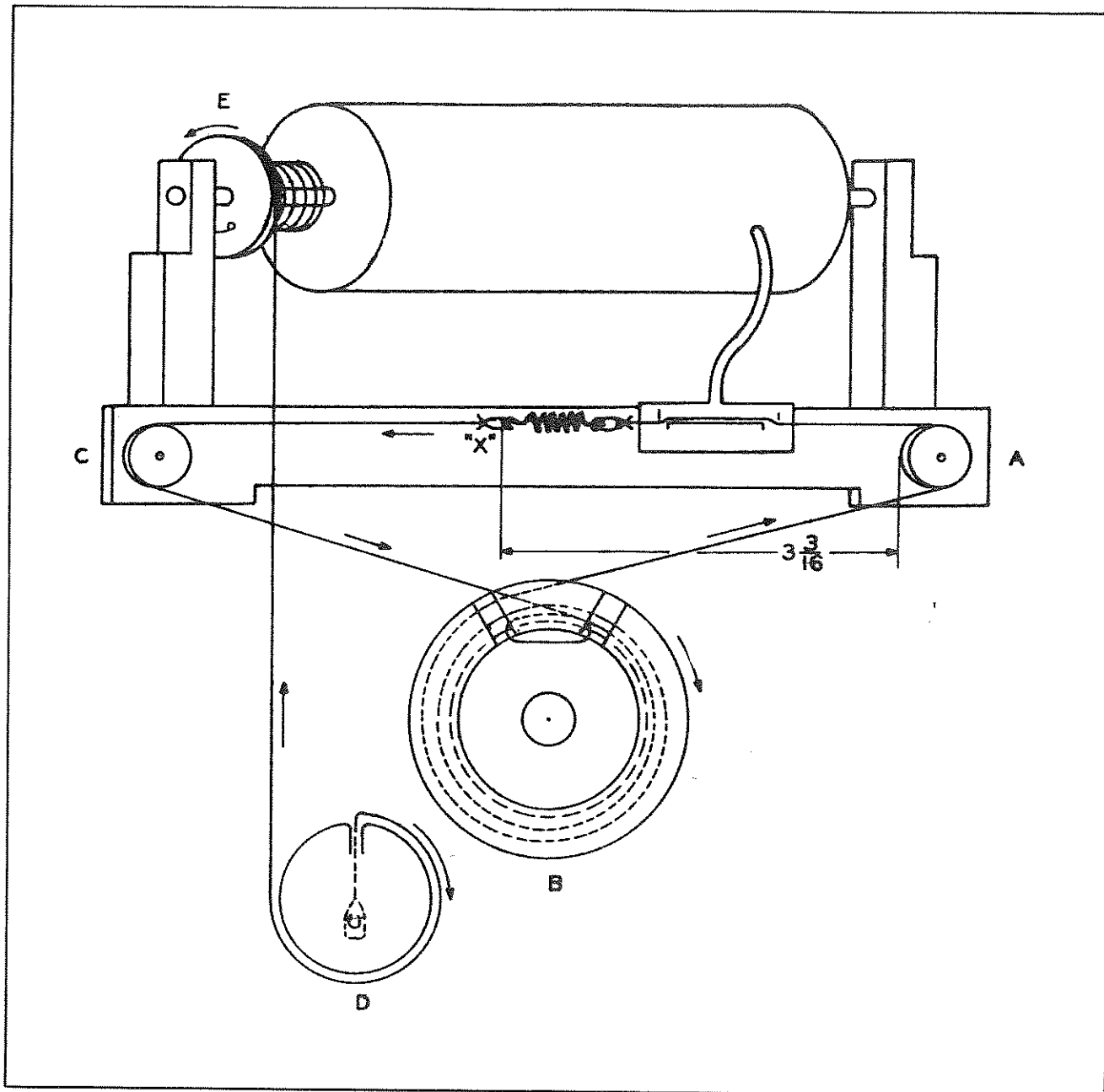

Figure 5-1. Dial Cord Replacement

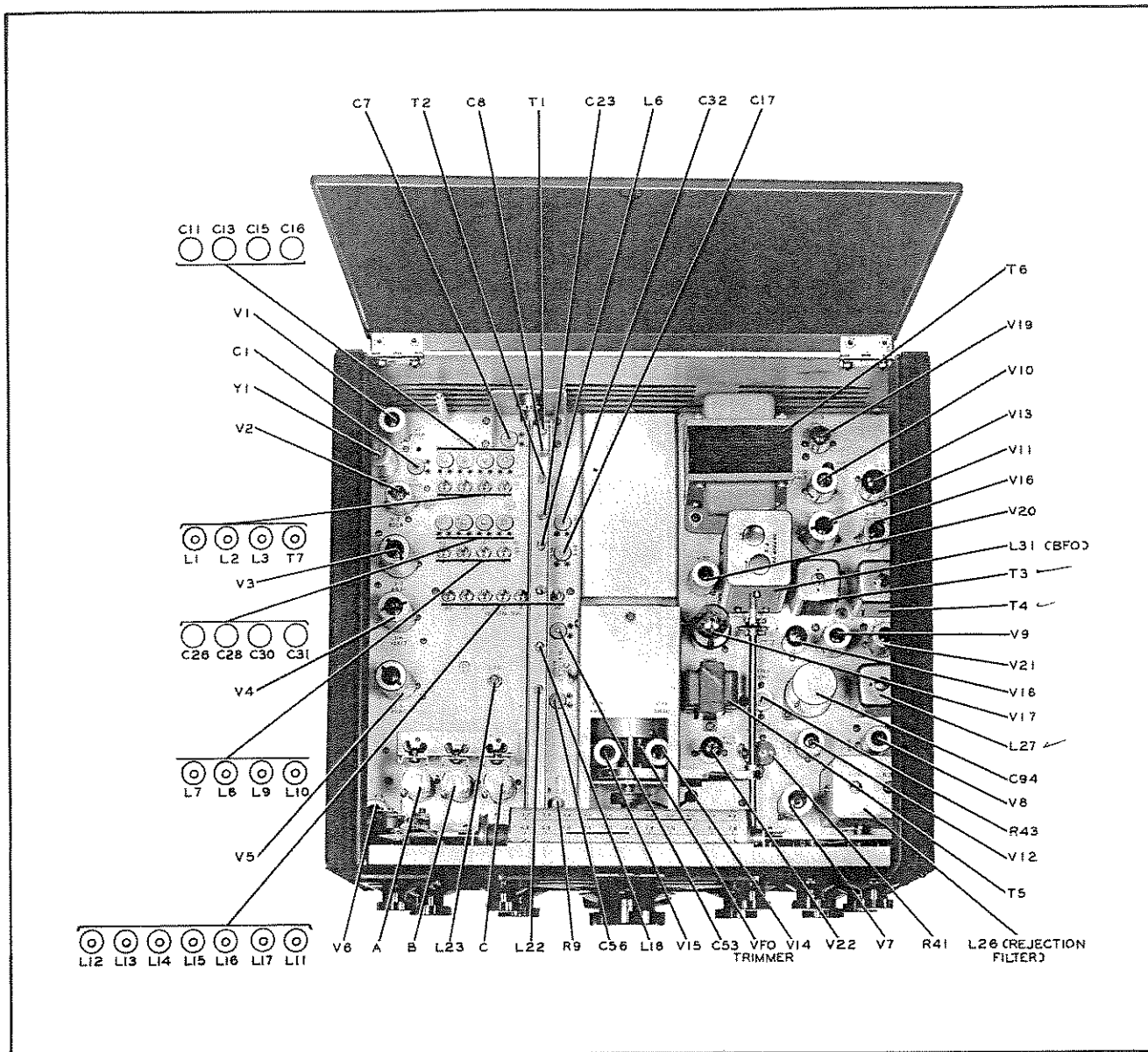

Figure 5-2. 75A-4, Top View

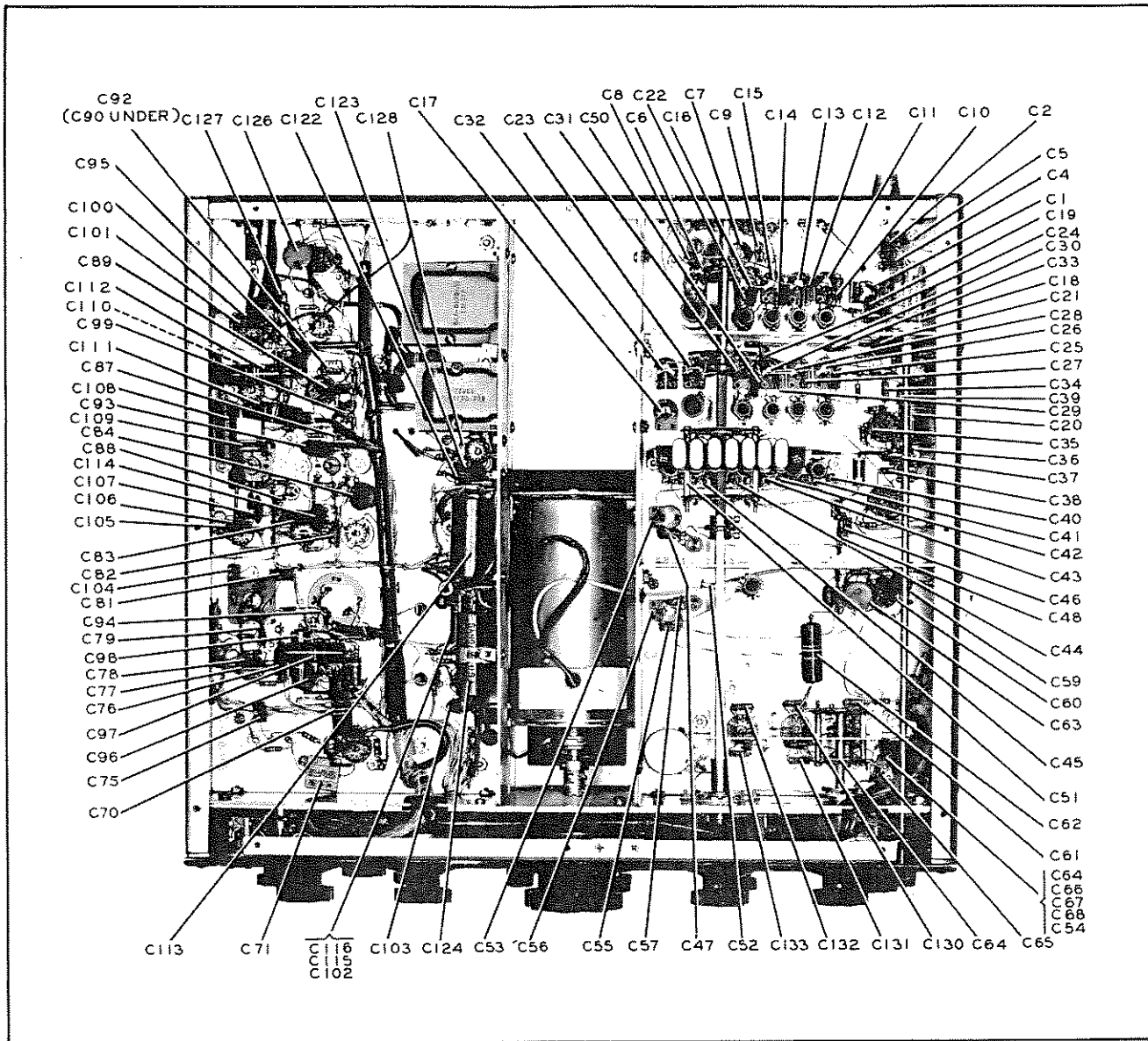

Figure 5-3. 75A-4, Bottom View, Page 1

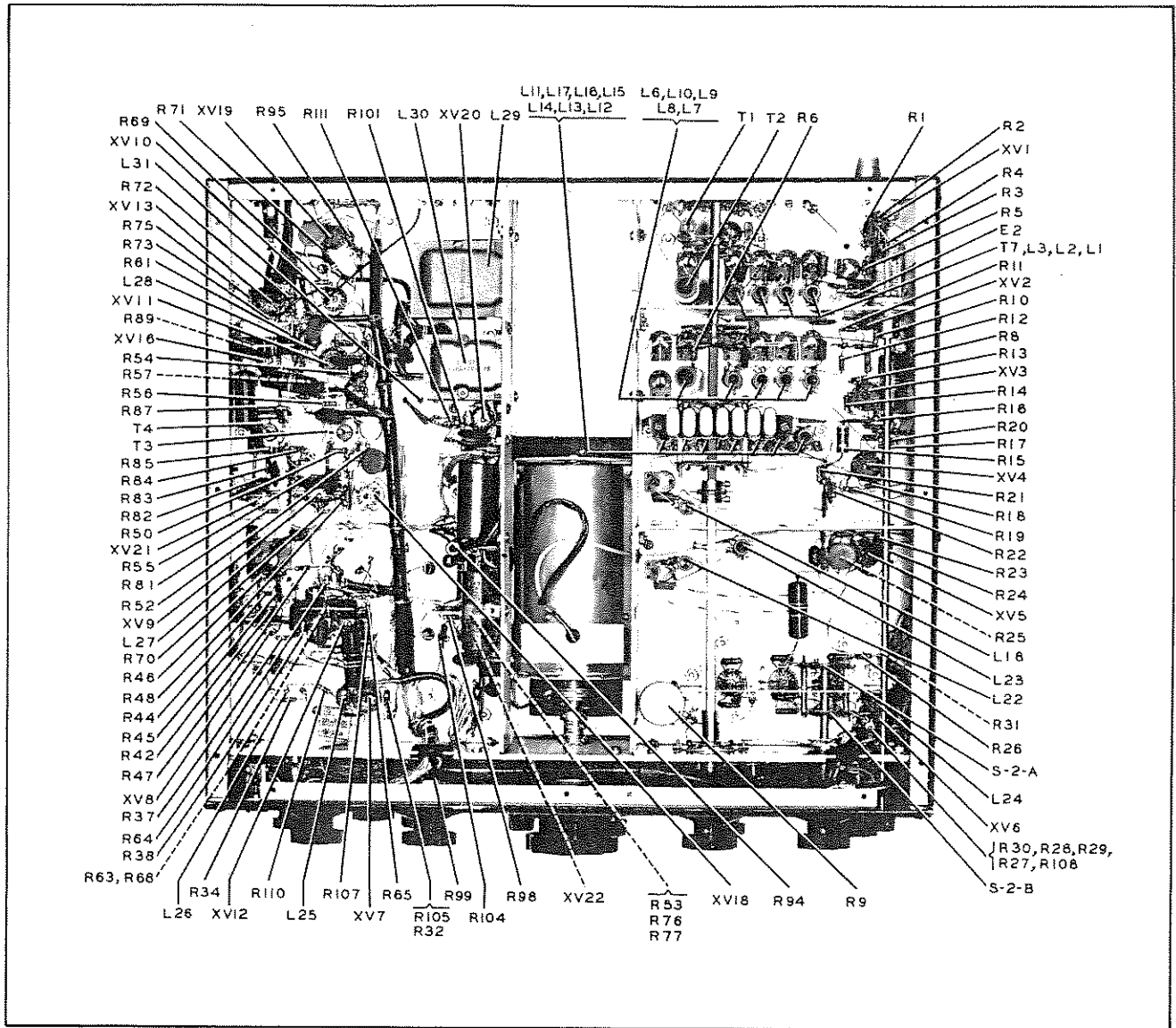

Figure 5-3. 75A-4, Bottom View, Page 2

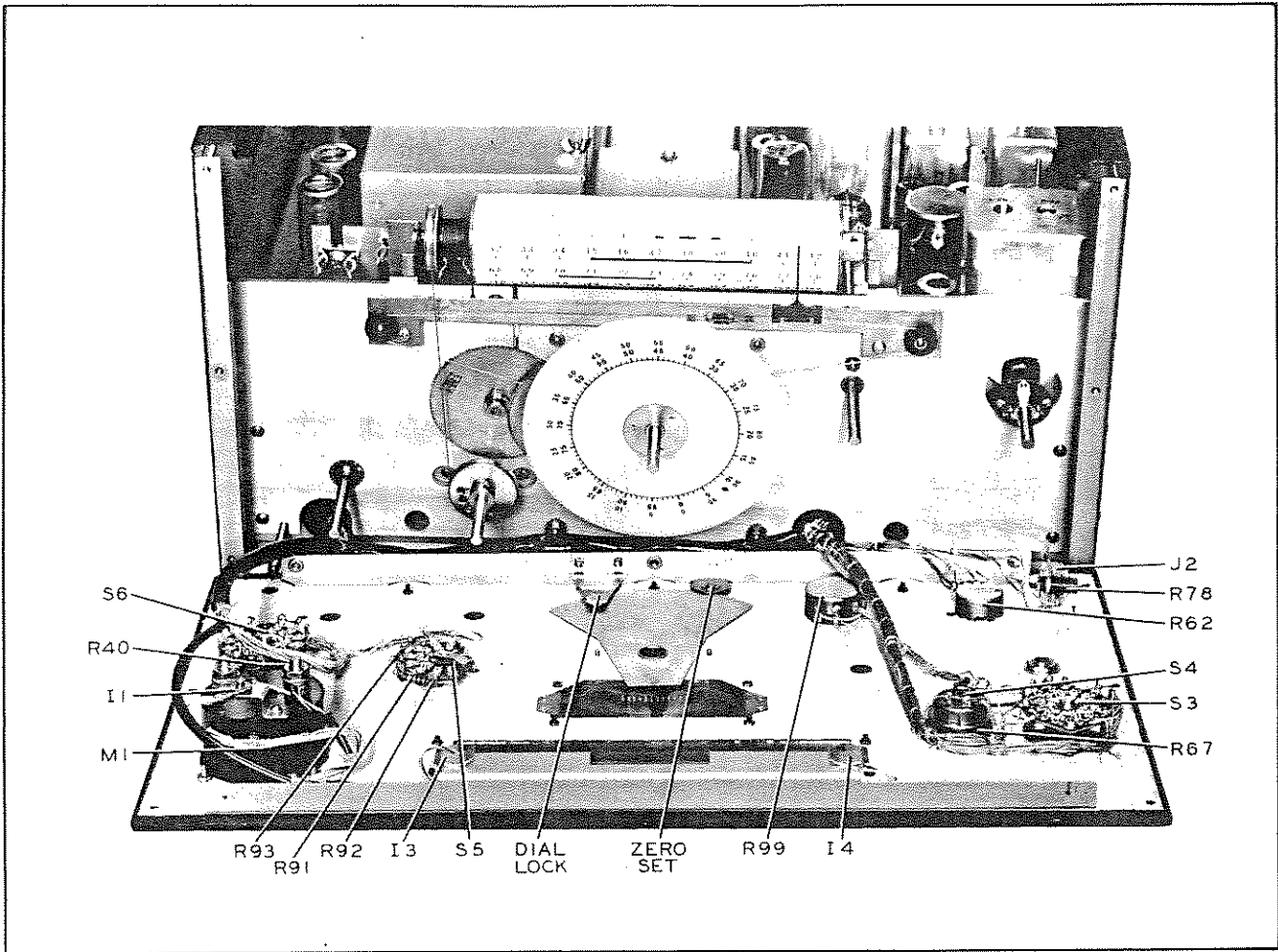

Figure 5-4. 75A-4, Front Panel Lowered

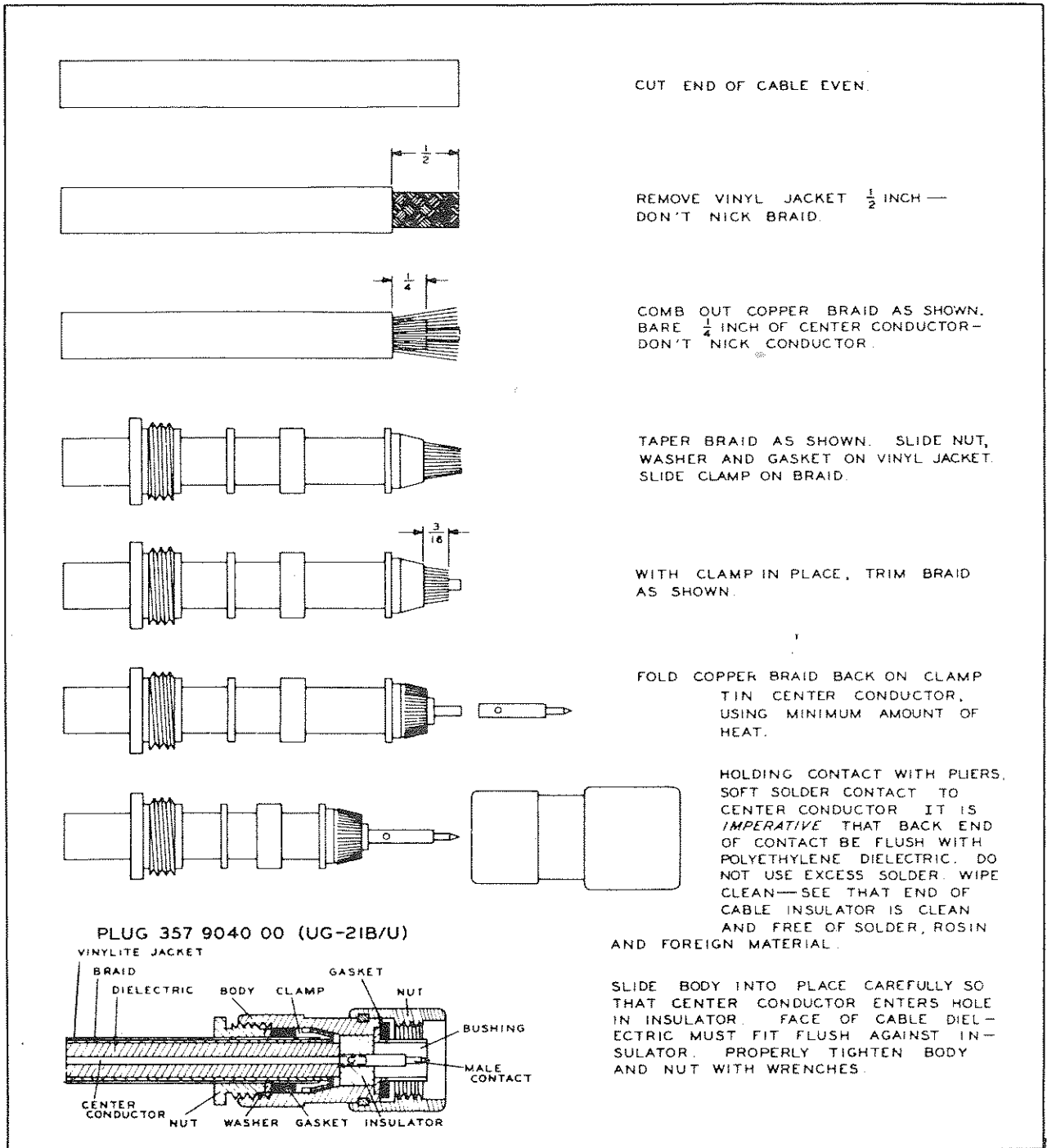

Figure 5-6. Assembling Plug UG-21B/U to Cable RG-8/U

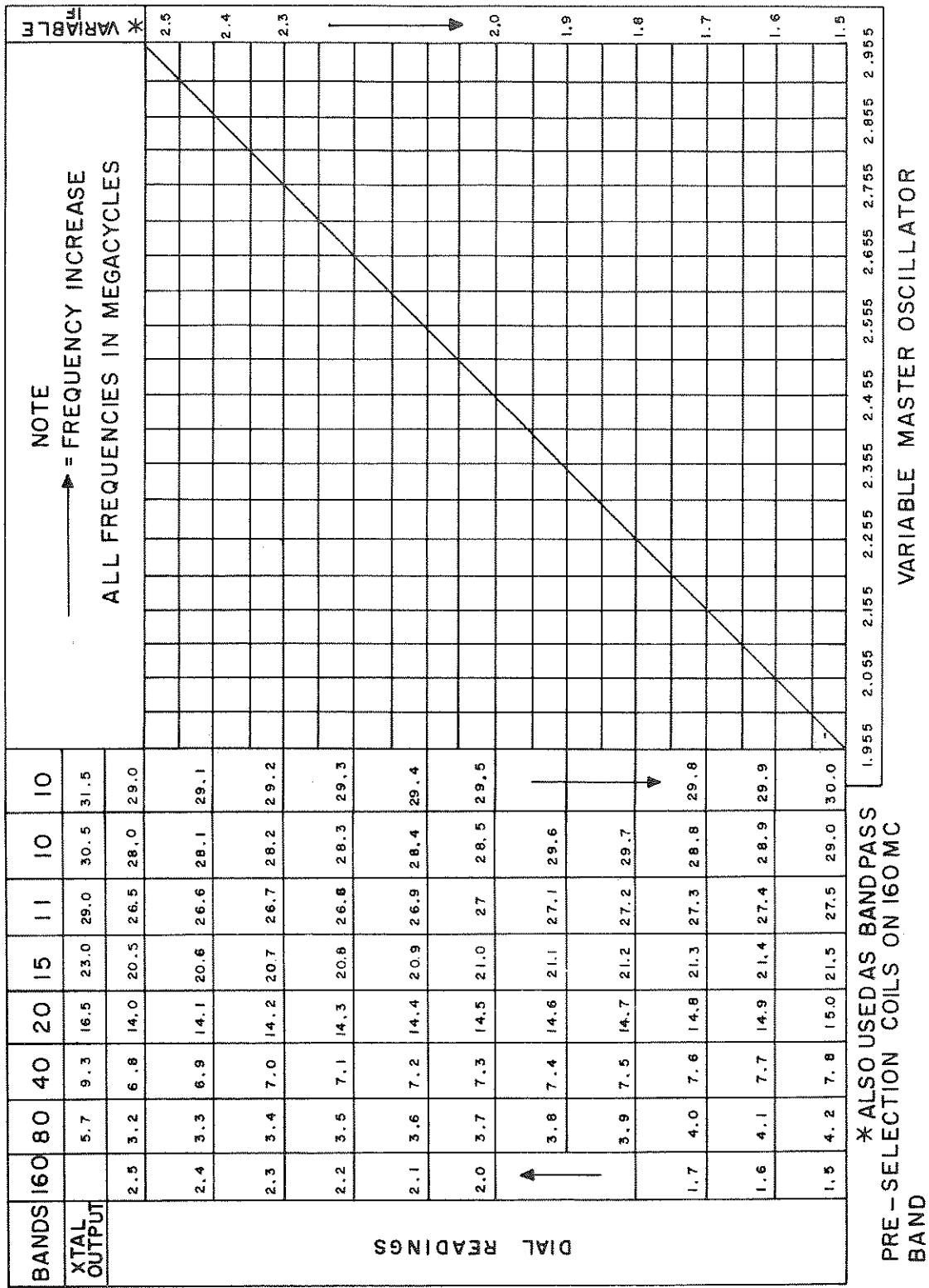
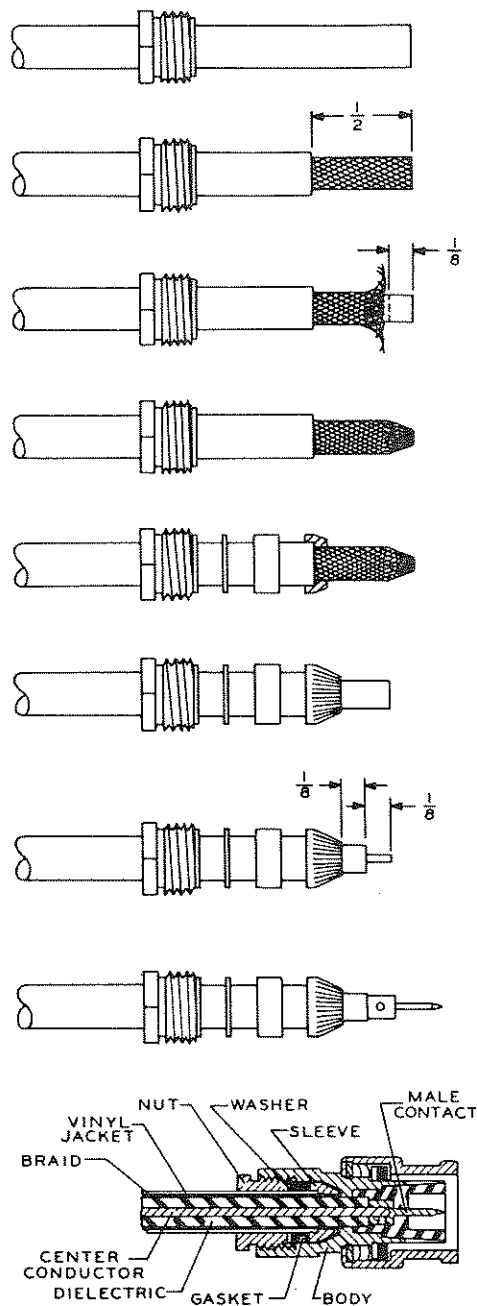

Figure 5-7. Dial Divisions Table



SLIDE NUT ONTO CABLE.
CUT END OF CABLE EVEN.

REMOVE VINYL JACKET FOR 1/2 INCH.
DO NOT NICK BRAID.

PUSH BRAID BACK AND REMOVE 1/8 INCH OF
DIELECTRIC AND CENTER CONDUCTOR

TAPER BRAID.

SLIDE WASHER, GASKET AND SLEEVE OVER TAPERED
BRAID. FIT INNER SHOULDER OF SLEEVE SQUARELY
AGAINST END OF JACKET.

COMB OUT BRAID, FOLD BACK SMOOTH AS SHOWN
AND TRIM 3/32 INCH.

BARE CENTER CONDUCTOR 1/8 INCH.
DO NOT NICK CONDUCTOR.

TIN CENTER CONDUCTOR. SLIP MALE CONTACT IN
PLACE AND SOLDER. REMOVE EXCESS SOLDER. BE
SURE THAT CABLE DIELECTRIC IS NOT HEATED EX-
CESSIVELY AND SWOLLEN SO AS TO PREVENT DI-
ELECTRIC FROM ENTERING BODY.

PUSH INTO BODY AS FAR AS IT WILL GO. SLIDE
GASKET, WASHER AND NUT INTO BODY. SCREW INTO
PLACE, WITH WRENCH, UNTIL MODERATELY TIGHT.
HOLD CABLE AND BODY RIGIDLY AND ROTATE NUT.

Figure 5-8. Assembling Plug UG-260/U to Cable UG-58/U

NOTES

SECTION VI PARTS LIST FOR 75A-4 RECEIVER

TABLE 6-1

ITEM	CIRCUIT FUNCTION	DESCRIPTION	COLLINS PART NUMBER
C-1	Calibration Oscillator frequency adjuster	CAPACITOR, variable: ceramic; 5-25 mmf; 350 wv	917 1073 00
C-2	V-1 Cathode bypass	CAPACITOR: ceramic; .01 mf, +100 -20%; 500 wv	913 3013 00
C-3	V-1 Screen bypass	CAPACITOR: mica; 200 mmf, $\pm 10\%$, 500 wv	912 0519 00
C-4	V-1 plate decoupling	CAPACITOR: ceramic; .01 mf, +100 -20%, 500 wv	913 3013 00
C-5	Calibration signal coupling	CAPACITOR: ceramic; 1 mmf, $\pm 1/4$ mmf, 500 wv	916 0070 00
C-6	Padder for T-1	CAPACITOR: mica; 390 mmf, $\pm 2\%$, 500 wv	912 0535 00
C-7	Trimmer for T-1	CAPACITOR, variable: ceramic; 8-50 mmf; 350 wv	917 1075 00
C-8	Trimmer for T-2	CAPACITOR, variable: ceramic; 8-50 mmf; 350 wv	917 1075 00
C-9	Padder for T-2	CAPACITOR: mica; 650 mmf, $\pm 2\%$, 500 wv	912 0548 00
C-10	Padder for L-1	CAPACITOR: mica; 300 mmf, $\pm 2\%$, 500 wv	912 0526 00
C-11	Trimmer for L-1	CAPACITOR, variable: ceramic; 8-50 mmf, 350 wv	917 1075 00
C-12	Padder for L-2	CAPACITOR: mica; 120 mmf, $\pm 5\%$, 500 wv	912 0500 00
C-13	Trimmer for L-2	CAPACITOR, variable: ceramic; 8-50 mmf, 350 wv	917 1075 00
C-14	Padder for L-3	CAPACITOR: mica; 68 mmf, $\pm 5\%$, 500 wv	912 0482 00
C-15	Trimmer for L-3	CAPACITOR, variable: ceramic; 8-50 mmf, 350 wv	917 1075 00
C-16	Trimmer for T-7	CAPACITOR, variable: ceramic; 5-25 mmf, 350 wv	917 1073 00
C-17	Trimmer for L-10	CAPACITOR, variable: ceramic; 5-25 mmf, 350 wv	917 1073 00

Section VI
PARTS LIST

TABLE 6-1 (Cont.)

ITEM	CIRCUIT FUNCTION	DESCRIPTION	COLLINS PART NUMBER
C-18	Antenna Trimmer	CAPACITOR, variable: air; 2.6-19.7 mmf	922 0033 00
C-19	V-2 grid blocking	CAPACITOR: mica; 100 mmf, $\pm 10\%$, 500 wv	912 0495 00
C-20	V-2 grid decoupling	CAPACITOR: paper; .1 mmf, $\pm 10\%$, 400 wv	931 0299 00
C-21	V-2 screen bypass	CAPACITOR: ceramic; .01 mf, +100 -20%, 500 wv	913 3013 00
C-22	Padder for T-7	CAPACITOR: mica; 24 mmf, $\pm 10\%$, 500 wv	912 0450 00
C-23	Trimmer for L-6	CAPACITOR, variable: ceramic; 8-50 mmf, 350 wv	917 1075 00
C-24	Padder for L-6	CAPACITOR: mica; 650 mmf, $\pm 20\%$, 500 wv	912 0548 00
C-25	Padder for L-7	CAPACITOR: mica; 300 mmf, $\pm 2\%$, 500 wv	912 0526 00
C-26	Trimmer for L-7	CAPACITOR, variable: ceramic; 8-50 mmf, 350 wv	917 1075 00
C-27	Padder for L-8	CAPACITOR: mica; 120 mmf, $\pm 5\%$, 500 wv	912 0500 00
C-28	Trimmer for L-8	CAPACITOR, variable: ceramic; 8-50 mmf, 350 wv	917 1075 00
C-29	Padder for L-9	CAPACITOR: mica; 68 mmf, $\pm 5\%$, 500 wv	912 0482 00
C-30	Trimmer for L-9	CAPACITOR, variable: ceramic; 8-50 mmf, 350 wv	917 1075 00
C-31	Trimmer for L-10	CAPACITOR, variable: ceramic; 5-25 mmf, 350 wv	917 1073 00
C-32	Trimmer for L-10	CAPACITOR, variable: ceramic; 5-25 mmf, 350 wv	917 1073 00
C-33	V-2 plate decoupling	CAPACITOR: ceramic; .01 mf, +100-20%, 500 wv	913 3013 00
C-34	V-3 grid blocking	CAPACITOR: mica; 100 mmf, $\pm 10\%$, 500 wv	912 0495 00
C-35	V-3 cathode bypass	CAPACITOR: ceramic; .01 mf, +100-20%, 500 wv	913 3013 00
C-36	V-3 screen bypass	CAPACITOR: ceramic; .01 mf, +100-20%, 500 wv	913 3013 00

TABLE 6-1 (Cont.)

ITEM	CIRCUIT FUNCTION	DESCRIPTION	COLLINS PART NUMBER
C-37	V-3 injection coupling	CAPACITOR: mica; 100 mmf, $\pm 10\%$, 500 wv	912 0495 00
C-38	V-4 plate feedback	CAPACITOR: mica; 220 mmf, $\pm 10\%$, 500 wv	912 0519 00
C-39	Padder for L-18	CAPACITOR: mica; 47 mmf, $\pm 5\%$, 500 wv	912 0470 00
C-40	Padder for L-12	CAPACITOR: mica; 220 mmf, $\pm 10\%$, 500 wv	912 0519 00
C-41	Padder for L-13	CAPACITOR: mica; 130 mmf, $\pm 10\%$, 500 wv	912 0502 00
C-42	Padder for L-14	CAPACITOR: mica; 120 mmf, $\pm 10\%$, 500 wv	912 0501 00
C-43	Padder for L-15	CAPACITOR: mica; 110 mmf, $\pm 2\%$, 500 wv	912 0496 00
C-44	Padder for L-16	CAPACITOR: mica; 56 mmf, $\pm 10\%$, 500 wv	912 0477 00
C-45	Padder for L-17	CAPACITOR: mica; 47 mmf, $\pm 10\%$, 500 wv	912 0471 00
C-46	V-4 plate decoupler	CAPACITOR: ceramic; .01 mf, +100 -20%, 500 wv	913 3013 00
C-47	Padder for L-18	CAPACITOR: mica; 330 mmf, $\pm 2\%$, 500 wv	912 0529 00
C-48	V-3 plate decoupler	CAPACITOR: ceramic; .01 mf, +100 -20%, 500 wv	913 3013 00
C-50	Padder for L-10	CAPACITOR: mica; 39 mmf, $\pm 10\%$, 500 wv	912 0465 00
C-51	Padder for L-11	CAPACITOR: mica; 47 mmf, $\pm 10\%$, 500 wv	912 0471 00
C-52	Coupler for L-18 and L-22	CAPACITOR: ceramic; 4 mmf, $\pm 1/2$ mmf, 500 wv	916 0114 00
C-53	Trimmer for L-18	CAPACITOR, variable: ceramic; 8-50 mmf, 350 wv	917 1075 00
C-54	V-6 cathode bypass	CAPACITOR: paper; .1 mf, $\pm 10\%$, 150-200 wv	931 0333 00
C-55	Padder for L-22	CAPACITOR: mica; 330 mmf, $\pm 2\%$, 500 wv	912 0529 00
C-56	Trimmer for L-22	CAPACITOR, variable: ceramic; 8-50 mmf, 350 wv	917 1075 00
C-57	Padder for L-22	CAPACITOR: mica; 75 mmf, $\pm 10\%$, 500 wv	912 0485 00
C-58	Tweet trap series	CAPACITOR: mica; 270 mmf, $\pm 2\%$, 500 wv	912 0523 00
C-59	V-5 cathode bypass	CAPACITOR: ceramic; .01 mf, +100-20%, 500 wv	913 3013 00

Section VI
PARTS LIST

TABLE 6-1 (Cont.)

ITEM	CIRCUIT FUNCTION	DESCRIPTION	COLLINS PART NUMBER
C-60	V-5 screen bypass	CAPACITOR: ceramic; .01 mf, +100-20%, 500 wv (p/o L-27)	913 3013 00
C-61	Mechanical filter padder	CAPACITOR: mica; 100 mmf, $\pm 2\%$, 500 wv	912 0493 00
C-62	V-5 plate decoupling	CAPACITOR: paper; .1 mmf, $\pm 10\%$, 400 wv	931 0299 00
C-63	B+ bypass	CAPACITOR: ceramic; .01 mf, +100-20%, 500 wv	913 3013 00
C-64	Mechanical filter padder	CAPACITOR: mica; 100 mmf, $\pm 2\%$, 500 wv	912 0493 00
C-65	V-6 grid decoupler	CAPACITOR: ceramic; .01 mf, +100-20%, 500 wv	913 3013 00
C-66	V-6 screen bypass	CAPACITOR: ceramic; .01 mf, +100-20%, 500 wv	913 3013 00
C-67	V-6 plate decoupling	CAPACITOR: ceramic; .01 mf, +100-20%, 500 wv	913 3013 00
C-68	V-6 plate to V-7 grid coupler	CAPACITOR: mica; 470 mmf, $\pm 10\%$, 500 wv	912 0543 00
C-69	External padder for L-27	CAPACITOR: mica; 33 mmf, $\pm 20\%$, 500 wv	912 0457 00
C-70	V-7 plate bypass	CAPACITOR: paper; .1 mf, $\pm 10\%$, 400 wv	931 0299 00
C-71	V-7 plate blocking	CAPACITOR: mica; 1000 mmf, $\pm 10\%$, 500 wv	935 5067 00
C-72	Rejection filter tuning	CAPACITOR, variable: air; 2.6-19.7 mmf	922 0033 00
C-73	Padder for L-26	CAPACITOR: mica; 1000 mmf, $\pm 2\%$, 500 wv	935 5064 00
C-74	Padder for L-26	CAPACITOR: mica; 1000 mmf, $\pm 2\%$, 500 wv	935 5064 00
C-75	V-8 grid coupling	CAPACITOR: mica; 470 mmf, $\pm 10\%$, 500 wv	912 0543 00
C-76	V-8 grid decoupling	CAPACITOR: ceramic; .01 mf, +100-20%, 500 wv	913 3013 00
C-77	V-8 cathode bypass	CAPACITOR: ceramic; .01 mf, +100-20%, 500 wv	913 3013 00
C-78	V-8 screen bypass	CAPACITOR: ceramic; .01 mf, +100-20%, 500 wv	913 3013 00
C-79	V-8 plate decoupling	CAPACITOR: ceramic; .01 mf, +100-20%, 500 wv	913 3013 00
C-80	Padder for L-27	CAPACITOR: 100 mmf, part of L-27	

TABLE 6-1 (Cont.)

ITEM	CIRCUIT FUNCTION	DESCRIPTION	COLLINS PART NUMBER
C-81	V-9 grid coupling	CAPACITOR: mica; 470 mmf, $\pm 10\%$, 500 wv	912 0543 00
C-82	V-9 grid decoupling	CAPACITOR: ceramic; .01 mf, +100-20%, 500 wv	913 3013 00
C-83	V-9 screen bypass	CAPACITOR: ceramic; .01 mf, +100-20%, 500 wv	913 3013 00
C-84	V-9 plate decoupling	CAPACITOR: ceramic; .01 mf, +100-20%, 500 wv	913 3013 00
C-85	T-3 primary padder	CAPACITOR: 500 mmf, part of T-3	
C-86	T-3 secondary padder	CAPACITOR: mica; 510 mmf, $\pm 5\%$, 300 wv	912 0545 00
C-87	V-11 grid coupler	CAPACITOR: mica; 10 mmf, $\pm 10\%$, 500 wv	912 0432 00
C-88	T-3 secondary bypass	CAPACITOR: mica; 330 mmf, $\pm 5\%$, 500 wv	912 0530 00
C-89	V-11 plate bypass	CAPACITOR: ceramic; .01 mf, +100-20%, 500 wv	913 3013 00
C-90	V-11 load filter	CAPACITOR: mica; 220 mmf, $\pm 10\%$, 500 wv	912 0519 00
C-91	V-11 load filter	CAPACITOR: mica; 220 mmf, $\pm 10\%$, 500 wv	912 0519 00
C-92	V-11 grid coupler from BFO	CAPACITOR: mica; 100 mmf, $\pm 10\%$, 500 wv	912 0495 00
C-93	AM detector audio output coupler	CAPACITOR: ceramic; .01 mf, +100-20%, 500 wv	913 3013 00
C-94 ABC	C-94A-Plate supply filter C-94B-Plate supply filter C-94C-V-11 plate decoupling	CAPACITOR: electrolytic; 40 mmf, -15% +100%, 300 wv	183 1115 00
C-95	CW detector audio output coupler	CAPACITOR: ceramic; .01 mf, +100-20%, 500 wv	913 3013 00
C-96	Noise limiter audio output coupler	CAPACITOR: ceramic; .01 mf, +100-20%, 500 wv	913 3013 00
C-97	V-12 cathode bypass	CAPACITOR: paper; .1 mmf, $\pm 10\%$, 400 wv	931 0299 00
C-98	V-12 plate decoupler	CAPACITOR: paper; .1 mmf, $\pm 10\%$, 400 wv	931 0299 00
C-99	V-11 grid divider	CAPACITOR: mica; 100 mmf, $\pm 10\%$, 500 wv	912 0495 00
C-100	V-13 grid coupling	CAPACITOR: ceramic; .01 mf, +100-20%, 500 wv	913 3013 00

Section VI
PARTS LIST

TABLE 6-1 (Cont.)

ITEM	CIRCUIT FUNCTION	DESCRIPTION	COLLINS PART NUMBER
C-101	V-22 grid coupling	CAPACITOR: ceramic; .01 mf, +100-20%, 500 wv	913 3013 00
C-102	V-22 grid decoupling	CAPACITOR: paper; 1 mf, +20-10% 200 wv	931 0170 00
C-103	V-22 plate stabilizing	CAPACITOR: ceramic; .01 mf, +100-20%, 500 wv	913 3013 00
C-104	V-21 grid coupling	CAPACITOR: mica; 470 mmf, ±10%, 500 wv	912 0543 00
C-105	V-21 cathode bypass	CAPACITOR: ceramic; .01 mf, +100-20%, 500 wv	913 3013 00
C-106	V-21 screen bypass	CAPACITOR: ceramic; .01 mf, +100-20%, 500 wv	913 3013 00
C-107	V-21 plate decoupling	CAPACITOR: ceramic; .01 mf, +100-20%, 500 wv	913 3013 00
C-108	V-16 cathode filter	CAPACITOR: paper; .1 mf, ±10%, 400 wv	931 0299 00
C-109	T-4 secondary tuning	CAPACITOR: mica; 510 mmf, ±5%, 300 wv	912 0545 00
C-110	V-16 cathode filter	CAPACITOR: mica; 330 mmf, ±5%, 500 wv	912 0530 00
C-111	V-16 plate bypass	CAPACITOR: paper; .1 mf, ±10%, 400 wv	931 0299 00
C-112	AVC time constant	CAPACITOR: paper; .1 mf, ±10%, 400 wv	931 0299 00
C-113	Bias supply filter	CAPACITOR: electrolytic; 50 mf, +100-10%, 150 wv	183 1045 00
C-114	V-9 cathode	CAPACITOR: ceramic; .01 mf, +100-20%, 500 wv	913 3013 00
C-115	Bias bypass	CAPACITOR: paper; .1 mf, ±10%, 400 wv	931 0299 00
C-116	V-18 anode bypass	CAPACITOR: paper; .1 mf, ±10%, 400 wv	931 0299 00
C-117	BFO tuning	CAPACITOR, variable: air; 23.7 mmf	922 0353 00
C-118	Trimmer for BFO	CAPACITOR, variable: air; 6-75 mmf	922 4200 00
C-119	Padder for BFO	CAPACITOR: mica; 1600 mmf, ±1%, 500 wv	912 1729 00
C-120	Padder for BFO	(p/o L-31)	
C-121	V-20 grid blocking	CAPACITOR: mica; 100 mmf, ±10%, 500 wv	912 0495 00
C-122	V-20 plate decoupling	CAPACITOR: ceramic; .01 mf, +100-20%, 500 wv	913 3013 00

TABLE 6-1 (Cont)

ITEM	CIRCUIT FUNCTION	DESCRIPTION	COLLINS PART NUMBER
C-123	V-20 screen bypass	CAPACITOR: ceramic; .01 mf, +100-20% 500 wv	913 3013 00
C-124	B+ bypass	CAPACITOR: paper; .5 mmf, +20%, -10% 200 wv	931 0169 00
C-125	T-4 primary tuning	CAPACITOR: 500 mmf, part of T-4	
C-126	115-V line bypass	CAPACITOR: ceramic; .01 mf, +100-20% 500 wv	913 3013 00
C-127	115-V line bypass	CAPACITOR: ceramic; .01 mf, +100-20% 500 wv	913 3013 00
C-128	V-20 feedback	CAPACITOR: ceramic; 4 mmf, $\pm 1/2$ mmf, 500 wv	916 0114 00
C-130	Mech. filter primary tuning	CAPACITOR: mica; 100 mmf, $\pm 2\%$, 500 wv	912 0493 00
C-131	Mech. filter secondary tuning	CAPACITOR: mica; 100 mmf, $\pm 2\%$, 500 wv	912 0493 00
C-132	Mech. filter primary tuning	CAPACITOR: mica; 100 mmf, $\pm 2\%$, 500 wv	912 0493 00
C-133	Mech. filter secondary tuning	CAPACITOR: mica; 100 mmf, $\pm 2\%$, 500 wv	912 0493 00
C-134		Not Used	
C-135		(p/o L-31)	
C-136		(p/o L-31)	
C-137	Bias supply filter	CAPACITOR: electrolytic; 50 mf, +100%, -10%, 150 wv	183 1045 00
C-138	Padder for C-31	CAPACITOR: mica; 10 mmf, $\pm 5\%$, 500 wv	912 0431 00
C-139	V-8 grid shunt	CAPACITOR: mica; 56 mmf, $\pm 5\%$, 500 wv	912 0476 00
C-140	Tweet trap tuning	CAPACITOR: ceramic; 18 mmf, $\pm 5\%$, 500 wv	916 4184 00
C-141	Muting circuit bypass	CAPACITOR: ceramic; .01 mf, +100-20%, 500 wv	913 3013 00
C-142	Pad for C-8	CAPACITOR: mica; 27 mmf; $\pm 5\%$; 500 wv	912 0452 00
C-143	Pad for C-23	CAPACITOR: mica; 27 mmf; $\pm 5\%$, 500 wv	912 0452 00
C-144	V-5 plate blocking	CAPACITOR: ceramic; .001 mf, +100-20%, 500 wv	913 1186 00
C-145	L-32 Resonating	CAPACITOR: mica; 62 mmf; $\pm 2\%$, 500 wv	912 0478 00
C-146	Filter	CAPACITOR: paper, .1 mf; $\pm 10\%$, 4 wv	931 0299 00
C-147	V-12 Cathode bypass	CAPACITOR: mica; 510 mmf; $\pm 5\%$, 300 wv	912 0545 00
C-148	V-12 Plate bypass	CAPACITOR: mica; 510 mmf; $\pm 5\%$, 300 wv	912 0545 00

Section VI
PARTS LIST

TABLE 6-1 (Cont)

ITEM	CIRCUIT FUNCTION	DESCRIPTION	COLLINS PART NUMBER
E-1	Antenna input connector	STRIP: terminal; 3 screw term on bakelite board	306 0033 00
E-2	V-2 grid suppressor	PARASITIC SUPPRESSOR: 47 ohm; #24 bus wire	504 7064 00
E-3	Muting-standby connector	STRIP: terminal; 4 screw term on bakelite board	306 0034 00
E-4	Audio output connector	STRIP: terminal; 4 screw term on bakelite board	306 0034 00
F-1	Primary fuse	FUSE: cartridge; 2 amp, 125 v Slo-Blo 3AG	264 0297 00
I-1	Meter lamp	LAMP: part of M-1	
I-2	KILOCYCLE dial bulb	LAMP: pilot light bulb w/ miniature bayonet base	262 3240 00
I-3	Megacycle dial bulb	LAMP: pilot light bulb w/ miniature bayonet base	262 3240 00
I-4	Megacycle dial bulb	LAMP: pilot light bulb w/ miniature bayonet base	262 3240 00
J-1	Antenna Coaxial input	CONNECTOR, receptacle: single round female contact	357 9183 00
J-2	Headphone connector	JACK: phone; 2 circuit for 1/4" diam plug	360 0025 00
J-3	Diode load test	CONNECTOR, receptacle: single round female contact	360 0062 00
J-4	AVC test	CONNECTOR, receptacle: single round female contact	360 0064 00
L-1	40 meter RF	COIL, RF: single wnd, single layer wnd, 18 turns #28 AWG DS wire	504 7000 001
L-2	20 meter RF	COIL, RF: single wnd, single layer wnd, 9 turns #28 AWG DS wire	504 6999 001
L-3	15 meter RF	COIL, RF: single wnd, single layer wnd, 7 turns #28 AWG DS wire	504 6997 001
L-6	80 meter mixer	COIL, RF: single wnd, single layer wnd, 16 turns #26 AWG DS wire	504 7037 002
L-7	40 meter mixer	COIL, RF: single wnd, single layer wnd, 18 turns #28 AWG DS wire	504 7000 001
L-8	20 meter mixer	COIL, RF: single wnd, single layer wnd, 9 turns #28 AWG DS wire	504 6999 001
L-9	15 meter mixer	COIL, RF: single wnd, single layer wnd, 7 turns #28 AWG DS wire	504 6997 001
L-10	11-10-10 meter mixer	COIL, RF: single layer wnd, 6 turns @19 turns per inch	540 4608 00

TABLE 6-1 (Cont.)

ITEM	CIRCUIT FUNCTION	DESCRIPTION	COLLINS PART NUMBER
L-11	10 meter crystal (high freq.)	COIL, RF: 23, 31, 33 mc; single wnd, single layer wnd, 5 turns #28 AWG DS wire	504 7001 001
L-12	80 meter crystal	COIL, RF: 5.7 mc, single wnd, single layer wnd, 16 turns #28 AWG E wire	504 7004 001
L-13	40 meter crystal *	COIL, RF: single wnd, single layer wnd, 12 turns #28 AWG DS wire	504 6998 001
L-14	20 meter crystal	COIL, RF: single wnd, single layer wnd, 7 turns #28 AWG DS wire	504 6997 001
L-15	15 meter crystal	COIL, RF: 23, 31, 33 mc; single wnd, single layer wnd, 5 turns #28 AWG DS wire	504 7001 001
L-16	11 meter crystal	COIL, RF: 23, 31, 33 mc; single wnd, single layer wnd, 5 turns #28 AWG DS wire	504 7001 001
L-17	10 meter crystal (low)	COIL, RF: 23, 31, 33 mc; single wnd, single layer wnd, 5 turns #28 AWG DS wire	504 7001 001
L-18	Variable IF. primary	COIL, RF: 1.5-2.5 mc, single wnd, single layer wnd, 52 turns #32 AWG E wire	504 7005 001
L-20	Tweet trap inductor	COIL, RF: single wnd, 3 pie universal wnd, 500 uh p/m 10%, at 1000 kc	240 0073 00
L-22	Variable IF. secondary	COIL, RF: 1.5-2.5 mc, single wnd, single layer wnd, 52 turns #32 AWG E wire	504 7005 001
L-23	5.7 mc tweet trap	COIL, RF: single pie, duo lat wnd, 124 turns litz wire	540 7017 002
L-24	V-16 plate	COIL, RF: 2 mh	240 0084 00
L-25	V-7 plate choke	COIL, RF: 2 mh	240 0084 00
L-26	Bridge T filter coil	COIL ASSY, Q Multiplier	540 4634 00
L-27	V-8 plate coil	COIL, RF: crystal filter grid; freq. range 440-470 kc (incl. C-60, C-80)	278 0085 00
L-28	V-11 detector output filter	COIL, RF: 2 mh	240 0084 00
L-29	Power supply filter	REACTOR: filter; 3.0 hy at 0.120 amp	668 0020 00
L-30	Power supply filter	REACTOR: filter; 5.0 hy at 0.080 amp	668 0019 00
L-31	BFO coil	COIL, RF: 70 turns (incl C-120, C-135, C-136)	540 3785 00
L-32	V-5 plate load	COIL, RF: 2 mh	240 0084 00

Section VI
PARTS LIST

TABLE 6-1 (Cont.)

ITEM	CIRCUIT FUNCTION	DESCRIPTION	COLLINS PART NUMBER
M-1	"S" meter	METER: single level; 1 ma DC, 50 ohm $\pm 20\%$, DC resistance, illuminated dial (incl. I-1)	458 0044 00
P-1	Antenna coaxial	CONNECTOR: male coax, UG-88/U	357 9018 00
P-2	Power connector	CONNECTOR: two conductor flexible AC cord	426 1003 00
R-1	V-1 grid	RESISTOR: 680,000 ohm $\pm 10\%$, 1/2 w	745 1471 00
R-2	V-1 cathode	RESISTOR: 4,700 ohm $\pm 10\%$, 1/2 w	745 1380 00
R-3	V-1 screen	RESISTOR: 100,000 ohm $\pm 10\%$, 1/2 w	745 1436 00
R-4	V-1 plate	RESISTOR: 220,000 ohm $\pm 10\%$, 1/2 w	745 1450 00
R-5	V-1 plate decoupling	RESISTOR: 10,000 ohm $\pm 10\%$, 1/2 w	745 1394 00
R-6	L-6 series	RESISTOR: 4,700 ohm $\pm 10\%$, 1/2 w	745 1380 00
R-7	V-2 grid	RESISTOR: 1.0 megohm $\pm 10\%$, 1/2 w	745 1478 00
R-8	V-2 grid decoupling	RESISTOR: 100,000 ohm $\pm 10\%$, 1/2 w	745 1436 00
R-9	V-6 cathode	RESISTOR: 2,500 ohms $\pm 20\%$, 1/4 w	376 4205 00
R-10	V-2 plate series	RESISTOR: 47 ohm $\pm 10\%$, 1/2 w	745 1296 00
R-11	V-2 screen	RESISTOR: 33,000 ohm $\pm 10\%$, 1/2 w	745 1415 00
R-12	V-2 plate decoupling	RESISTOR: 2,200 ohm $\pm 10\%$, 1/2 w	745 1366 00
R-13	V-3 grid	RESISTOR: 470,000 ohm $\pm 10\%$, 1/2 w	745 1464 00
R-14	V-3 cathode	RESISTOR: 120 ohm $\pm 10\%$, 1/2 w	745 1314 00
R-15	V-3 screen	RESISTOR: 4,700 ohm $\pm 10\%$, 2 w	745 5680 00
R-16	V-3 injection grid	RESISTOR: 22,000 ohm $\pm 10\%$, 1/2 w	745 1408 00
R-17	V-4 cathode	RESISTOR: 330 ohm $\pm 10\%$, 1/2 w	745 1331 00
R-18	V-4 cathode	RESISTOR: 330 ohm $\pm 10\%$, 1/2 w	745 1331 00
R-19	V-4 plate series	RESISTOR: 47 ohm $\pm 10\%$, 1/2 w	745 1296 00
R-20	V-4 grid	RESISTOR: 10,000 ohm $\pm 10\%$, 1/2 w	745 1394 00
R-21	V-4 plate decoupling	RESISTOR: 2200 ohm $\pm 10\%$, 1/2 w	745 1366 00

TABLE 6-1 (Cont.)

ITEM	CIRCUIT FUNCTION	DESCRIPTION	COLLINS PART NUMBER
R-22	V-3 plate decoupling	RESISTOR: 2200 ohm $\pm 10\%$, 1/2 w	745 1366 00
R-23	V-5 grid	RESISTOR: 100,000 ohm $\pm 10\%$, 1/2 w	745 1436 00
R-24	V-5 cathode	RESISTOR: 68 ohm $\pm 10\%$, 1/2 w	745 1303 00
R-25	V-5 screen	RESISTOR: 8200 ohm $\pm 10\%$, 2 w	745 5691 00
R-26	V-5 plate decoupling	RESISTOR: 2200 ohm $\pm 10\%$, 1/2 w	745 1366 00
R-27	V-6 grid decoupling	RESISTOR: 3.3 megohm $\pm 10\%$, 1/2 w	745 1499 00
R-28	V-6 "S" meter dropping	RESISTOR: 68,000 ohm $\pm 10\%$, 1/2 w	745 1429 00
R-29	L-24 shunt	RESISTOR: 15,000 ohm $\pm 10\%$, 1/2 w	745 1401 00
R-30	V-6 screen	RESISTOR: 47,000 ohm $\pm 10\%$, 1/2 w	745 1422 00
R-31	V-6 plate decoupling	RESISTOR: 2200 ohms $\pm 10\%$, 1/2 w	745 1366 00
R-32	V-7 cathode	RESISTOR: 680 ohm $\pm 10\%$, 1/2 w	745 1345 00
R-33	V-7 plate dropping	RESISTOR: 2200 ohm $\pm 10\%$, 1/2 w	745 1366 00
R-34	V-7 plate load	RESISTOR: 330,000 ohm $\pm 10\%$, 1/2 w	745 1457 00
R-35	Bridge T adjustor series	RESISTOR: 30,000 ohm $\pm 1\%$, 1/2 w	705 2166 00
R-36	Bridge T regeneration adjuster	RESISTOR: 10,000 ohm $\pm 20\%$, 1/4 w	376 4207 00
R-37	V-8 grid	RESISTOR: 1.0 megohm $\pm 10\%$, 1/2 w	745 1478 00
R-38	V-8 grid decoupling	RESISTOR: 22,000 ohm $\pm 10\%$, 1/2 w	745 1408 00
R-39	"S" meter bridge	RESISTOR: 150 ohm $\pm 10\%$, 1/2 w	745 1317 00
R-41	"S" meter SENS adjust	RESISTOR: 500 ohm $\pm 10\%$, 2 w, wire wound	750 8081 00
R-43	"S" meter zero	RESISTOR: 500 ohm $\pm 10\%$, 2 w, wire wound	750 8081 00
R-44	V-8 "S" meter dropping	RESISTOR: 68,000 ohm $\pm 10\%$, 1/2 w	745 1429 00
R-45	V-8 screen	RESISTOR: 47,000 ohm $\pm 10\%$, 1/2 w	745 1422 00
R-46	L-27 shunt	RESISTOR: 22,000 ohm $\pm 10\%$, 1/2 w	745 1408 00
R-47	V-8 plate decoupling	RESISTOR: 220 ohm $\pm 10\%$, 1/2 w	745 1366 00

*Some Receivers may have a 1000-ohm potentiometer with a fixed 1000 ohm resistor in shunt. Use the 500-ohm potentiometer here listed for replacement purposes without the 1000 ohm shunt resistor.

Section VI
PARTS LIST

TABLE 6-1 (Cont.)

ITEM	CIRCUIT FUNCTION	DESCRIPTION	COLLINS PART NUMBER
R-48	V-9 grid	RESISTOR: 3.3 megohm $\pm 10\%$, 1/2 w	745 1499 00
R-49	V-9 grid decoupling	RESISTOR: 22,000 ohm $\pm 10\%$, 1/2 w	745 1408 00
R-50	T-3 primary shunt	RESISTOR: 4700 ohm $\pm 10\%$, 1/2 w	745 1422 00
R-51	V-9 screen	RESISTOR: 4700 ohm $\pm 10\%$, 1/2 w	745 1422 00
R-52	V-9 plate decoupling	RESISTOR: 2200 ohm $\pm 10\%$, 1/2 w	745 1366 00
R-53	V-9 grid bleeder	RESISTOR: 68,000 ohm $\pm 10\%$, 1/2 w	745 1429 00
R-54	V-11 grid	RESISTOR: 100,000 ohm $\pm 10\%$, 1/2 w	745 1436 00
R-55	V-9 cathode	RESISTOR: 150 ohm $\pm 10\%$, 1/2 w	745 1317 00
R-56	V-10A diode load	RESISTOR: 22,000 ohm $\pm 10\%$, 1/2 w	745 1408 00
R-57	V-10A diode load	RESISTOR: 4700 ohm $\pm 10\%$, 1/2 w	745 1422 00
R-58	V-11 cathode	RESISTOR: 820 ohm $\pm 10\%$, 1/2 w	745 1349 00
R-59	V-11 grid	RESISTOR: 100,000 ohm $\pm 10\%$, 1/2 w	745 1436 00
R-60	V-11 plate load	RESISTOR: 47,000 ohm $\pm 10\%$, 1/2 w	745 1422 00
R-61	V-11 plate decoupling	RESISTOR: 15,000 ohm $\pm 10\%$, 1/2 w	745 1401 00
R-62	AF gain control	RESISTOR: 500,000 ohm $\pm 20\%$, 1/4 w	376 4499 00
R-63	V-12 plate load	RESISTOR: 470,000 ohm $\pm 10\%$, 1/2 w	745 1464 00
R-64	V-12 plate dropping	RESISTOR: 680,000 ohm $\pm 10\%$, 1/2 w	745 1471 00
R-65	V-12 cathode	RESISTOR: 220,000 ohm $\pm 10\%$, 1/2 w	745 1450 00
R-66	V-12 cathode	RESISTOR: 47,000 ohm $\pm 10\%$, 1/2 w	745 1422 00
R-67	Noise limiter adjust	RESISTOR: 500,000 ohm $\pm 20\%$, 1/2 w (Incl. S-4)	376 5701 00
R-68	V-12 plate load	RESISTOR: 220,000 ohm $\pm 10\%$, 1/2 w	745 1450 00
R-69	V-13 cathode	RESISTOR: 3300 ohm $\pm 10\%$, 1/2 w	745 1373 00
R-70	V-9 grid bleeder	RESISTOR: 470,000 ohm $\pm 10\%$, 1/2 w	745 1464 00
R-71	V-9 feedback	RESISTOR: 33,000 ohm $\pm 10\%$, 1/2 w	745 1415 00
R-72	V-13 plate load	RESISTOR: 270,000 ohm $\pm 10\%$, 1/2 w	745 1454 00

TABLE 6-1 (Cont.)

ITEM	CIRCUIT FUNCTION	DESCRIPTION	COLLINS PART NUMBER
R-73	V-13 plate load	RESISTOR: 270,000 ohm $\pm 10\%$, 1/2 w	745 1454 00
R-74	V-13 cathode	RESISTOR: 3300 ohm $\pm 10\%$, 1/2 w	745 1373 00
R-75	V-13 grid	RESISTOR: 470,000 ohm $\pm 10\%$, 1/2 w	745 1464 00
R-76	V-22 grid	RESISTOR: 100,000 ohm $\pm 10\%$, 1/2 w	745 1436 00
R-77	V-22 grid bias series	RESISTOR: 180,000 ohm $\pm 10\%$, 1/2 w	745 1447 00
R-78	Audio load	RESISTOR: 10 ohm $\pm 10\%$, 2 w	745 9013 00
R-81	V-21 grid	RESISTOR: 1.0 megohm $\pm 10\%$, 1/2 w	745 1478 00
R-82	V-21 cathode	RESISTOR: 150 ohm $\pm 10\%$, 1/2 w	745 1317 00
R-83	V-21 screen	RESISTOR: 47,000 ohm $\pm 10\%$, 1/2 w	745 1422 00
R-84	V-21 plate decoupling	RESISTOR: 2200 ohm $\pm 10\%$, 1/2 w	745 1366 00
R-85	T-4 primary shunt	RESISTOR: 47,000 ohm $\pm 10\%$, 1/2 w	745 1422 00
R-86	V-16 diode load	RESISTOR: 39,000 ohm $\pm 10\%$, 1 w	745 3419 00
R-87	V-16 diode load	RESISTOR: 3300 ohm $\pm 10\%$, 1/2 w	745 1373 00
R-88	V-16 plate load	RESISTOR: 2.2 megohm $\pm 10\%$, 1/2 w	745 1492 00
R-89	V-16 diode load	RESISTOR: 10,000 ohm $\pm 10\%$, 1/2 w	745 1394 00
R-90	AVC time constant	RESISTOR: 2200 ohm $\pm 10\%$, 1/2 w	745 1366 00
R-91	AVC time constant "fast"	RESISTOR: 330,000 ohm $\pm 10\%$, 1/2 w	745 1457 00
R-92	AVC time constant "slow"	RESISTOR: 3.3 megohm $\pm 10\%$, 1/2 w	745 1499 00
R-93	RF gain bleeder	RESISTOR: 330,000 ohm $\pm 10\%$, 1/2 w	745 1457 00
R-94	Voltage regulator dropping	RESISTOR: 2500 ohm $\pm 10\%$, 10 w	710 0030 00
R-95	V-19 plate series	RESISTOR: 1000 ohm $\pm 10\%$, 1/2 w	745 1352 00
R-96	Bias rectifier filter	RESISTOR: 4700 ohm $\pm 10\%$, 1/2 w	745 1380 00
R-97	Bias rectifier filter	RESISTOR: 15,000 ohm $\pm 10\%$, 1/2 w	745 1401 00
R-98	Standby bias divider	RESISTOR: 22,000 ohm $\pm 10\%$, 1/2 w	745 1408 00
R-99	RF gain control	RESISTOR: 10,000 ohm $\pm 20\%$, 1/2 w	376 3522 00
R-100	V-20 plate decoupling	RESISTOR: 2200 ohm $\pm 10\%$, 1/2 w	745 1366 00

Section VI
PARTS LIST

TABLE 6-1 (Cont)

ITEM	CIRCUIT FUNCTION	DESCRIPTION	COLLINS PART NUMBER
R-101	V-20 grid	RESISTOR: 150,000 ohm $\pm 10\%$, 1/2 w	745 1443 00
R-102	V-20 plate	RESISTOR: 100,000 ohm $\pm 10\%$, 1/2 w	745 1436 00
R-103	V-20 screen	RESISTOR: 150,000 ohm $\pm 10\%$, 1/2 w	745 1443 00
R-104	RF gain series	RESISTOR: 270 ohm $\pm 10\%$, 1/2 w	745 1328 00
R-105	V-7 grid	RESISTOR: 100,000 ohm $\pm 10\%$, 1/2 w	745 1436 00
R-106	V-20 B+ divider	RESISTOR: 10,000 ohm $\pm 10\%$, 1/2 w	745 1394 00
R-107	V-12 filament dropping	RESISTOR: 10 ohm $\pm 10\%$, 2 w	745 5568 00
R-108	AVC bleeder	Deleted	
R-109	Audio Feedback	RESISTOR: 390,000 ohm $\pm 10\%$, 1/2 w	745 1461 00
R-110	V-7 grid	RESISTOR: 47 ohm $\pm 10\%$, 1/2 w	745 1296 00
R-111	V-20 grid series	RESISTOR: 47 ohm $\pm 10\%$, 1/2 w	745 1296 00
R-112	V-22 screen	RESISTOR: 3300 ohm $\pm 10\%$, 1 w	745 3373 00
R-113	V-7 Parasitic suppressor	RESISTOR: 120 ohm $\pm 10\%$, 1/2 w	745 1314 00
R-114	V-5 Parasitic suppressor	RESISTOR: 47 ohm $\pm 10\%$, 1/2 w	745 1296 00
R-115	Limiter bias bleeder	RESISTOR: 1200 ohm $\pm 10\%$, 1/2 w	745 1356 00
R-116	Limiter bias series	RESISTOR: 100,000 ohm $\pm 10\%$, 1 w	745 3436 00
R-117	Filter	RESISTOR: 47,000 ohm $\pm 10\%$, 1/2 w	745 1422 00
R-118	NL Feedback	RESISTOR: 6800 ohm $\pm 10\%$, 1/2 w	745 1387 00
R-130	IF GAIN divider	RESISTOR: 56K $\pm 10\%$, 2 w	745 5726 00
R-131	AVC diode load	RESISTOR: 330K $\pm 10\%$, 1/2 w	745 1457 00
S-1A	Band switch, ant coil sel.	SWITCH SECTION, rotary: 2 circuit, 12 position, shorting	269 1689 00
S-1B	Band switch, RF coil sel.	SWITCH SECTION , rotary: 2 circuit, 12 position, shorting	269 1690 00
S-1C	Band switch, mixer coil sel.	SWITCH SECTION, rotary: 2 circuit, 12 position, shorting	269 1690 00
S-1D	Band switch, crystal sel.	SWITCH SECTION, rotary: 1 circuit, 12 position, shorting	269 1688 00
S-1E	Band switch, crystal coil sel.	SWITCH SECTION, rotary: 1 circuit, 12 position, shorting	269 1688 00
S-1F	Band switch, 10-10-11 meter padder selector	SWITCH SECTION, rotary: 1 circuit, 12 position, shorting	269 1691 00
S-2	S-2A, S-2B	SWITCH, rotary: detent, 3 position 30° angle of detent	269 1435 00

TABLE 6-1 (Cont)

ITEM	CIRCUIT FUNCTION	DESCRIPTION	COLLINS PART NUMBER
S-2A	Mechanical filter primary selector	SWITCH SECTION, rotary: 1 circuit, 12 position, shorting	269 1666 00
S-2B	Mechanical filter secondary selector	SWITCH SECTION, rotary: 1 circuit, 12 position, shorting	269 1667 00
S-3	AM-CW-SSB selector switch	SWITCH, rotary: 4 circuit, 2 position, non-shorting	259 0655 00
S-4	Noise limiter on-off	SWITCH: part of R-67	
S-5	AVC selector switch	SWITCH, rotary: 2 circuit, 3 position, non-shorting	259 0417 00
S-6	OFF-STANDBY-ON-CAL selector switch	SWITCH, rotary: 3 circuit, 4 position, positive shorting	259 0656 00
T-1	160 meter RF coil	COIL, RF: two wnd, single layer wnd, one wnd, w/51 turns, other wnd w/4 turns	504 7038 002
T-2	80 meter RF coil	COIL, RF: two wnd, single layer wnd, one wnd, w/16 turns, other wnd w/3 turns	504 7039 002
T-3	455 KC IF. coil	TRANSFORMER: intermediate freq. 455; freq. range 440-470 KC (incl. C-85)	278 0197 00
T-4	AVC 455 KC IF. coil	TRANSFORMER: intermediate freq: 455; freq. range 440-470 KC	278 0197 00
T-5	Audio output transformer	TRANSFORMER: audio output; pri 5000 ohm; secd 500 ohm tapped at 4 ohm, 2500 TV	667 0018 00
T-6	Power transformer	TRANSFORMER, power: pri 115 v, secd #1; 100 v CT, secd #2; 5.0 v secd #3; 6.3 v 1500 TV, 50/60 cps	662 0145 00
T-7	11-10-10 meter RF coil	COIL ASSY: 6 turns @ 19 turns per inch	540 4609 00
V-1	Calibrator	TUBE: type 6BA6; pentode	255 0185 00
V-2	RF amplifier	TUBE: type 6DC6; pentode	255 0226 00
V-3	First mixer	TUBE: type 6BA7; pentagrid	255 0209 00
V-4	HF crystal osc.	TUBE: type 12AT7; double triode	255 0205 00
V-5	Second mixer	TUBE: type 6BA7; pentagrid	255 0209 00
V-6	Mechanical filter 455 IF. amplifier	TUBE: type 6BA6; pentode	255 0185 00
V-7	"Q" multiplier	TUBE: type 12AX7; double triode	255 0201 00

Section VI
PARTS LIST

TABLE 6-1 (Cont.)

ITEM	CIRCUIT FUNCTION	DESCRIPTION	COLLINS PART NUMBER
V-8	455 KC IF. amplifier	TUBE: type 6BA6; pentode	255 0185 00
V-9	455 KC IF. amplifier	TUBE: type 6BA6; pentode	255 0185 00
V-10	AM detector muting diode	TUBE: type 6AL5; double diode	257 0018 00
V-11	CW-SSB detector	TUBE: type 12AU7; twin triode	255 0199 00
V-12	Noise limiter	TUBE: type 6AL5; double diode	257 0018 00
V-13	Audio amplifier	TUBE: type 12AT7; double triode	255 0205 00
V-14	VFO oscillator	TUBE: type 6BA6; pentode	255 0250 00
V-15	VFO amplifier	TUBE: type 6BA6; pentode	255 0250 00
V-16	AVC Det-noise clipper	TUBE: type 6AL5; double diode	257 0018 00
V-17	Power rectifier	TUBE: type 5Y3GT; full wave rectifier	255 0157 00
V-18	Voltage regulator	TUBE: type OA2	257 0052 00
V-19	RF gain gate - Bias rectifier	TUBE: type 6AL5; double diode	257 0018 00
V-20	BFO	TUBE: type 6BA6; pentode	255 0185 00
V-21	AVC amplifier	TUBE: type 6BA6; pentode	255 0185 00
V-22	Audio output	TUBE: type 6AQ5; beam pentode	255 0195 00
XF-1	Holder for F-1	FUSE HOLDER: extractor post for 3AG fuse	265 1002 00
XFL-1	Socket for Mechanical filter	SOCKET, tube: 9 contact miniature	220 1216 00
XFL-2	Socket for Mechanical filter	SOCKET, tube: 9 contact miniature	220 1216 00
XFL-3	Socket for Mechanical filter	SOCKET, tube: 9 contact miniature	220 1216 00
XI-3	Socket for I-3	LAMP HOLDER: bracket for miniature bayonet base bulb	262 1210 00
XI-4	Socket for I-4	LAMP HOLDER: bracket for miniature bayonet base bulb	262 1210 00
XV-1	Socket for V-1	SOCKET, tube: 7 contact miniature	220 1034 00
XV-2	Socket for V-2	SOCKET, tube: 7 contact miniature	220 1034 00
XV-3	Socket for V-3	SOCKET, tube: 9 contact miniature	220 1062 00
XV-4	Socket for V-4	SOCKET, tube: 9 contact miniature	220 1062 00

TABLE 6-1 (Cont.)

ITEM	CIRCUIT FUNCTION	DESCRIPTION	COLLINS PART NUMBER
XV-5	Socket for V-5	SOCKET, tube: 9 contact miniature	220 1062 00
XV-6	Socket for V-6	SOCKET, tube: 7 contact miniature	220 1034 00
XV-7	Socket for V-7	SOCKET, tube: 9 contact miniature	220 1062 00
XV-8, XV-9, XV-10	Socket for V-8, V-9, V-10	SOCKET, tube: 7 contact miniature	220 1034 00
XV-11	Socket for V-11	SOCKET, tube: 9 contact miniature	220 1062 00
XV-12	Socket for V-12	SOCKET, tube: 7 contact miniature	220 1034 00
XV-13	Socket for V-13	SOCKET, tube: 9 contact miniature	220 1052 00
XV-16	Socket for V-16	SOCKET, tube: 7 contact miniature	220 1034 00
XV-17	Socket for V-17	SOCKET, tube: 8 contact miniature	220 1157 00
XV-18, XV-19	Socket for V-18, V-19	SOCKET, tube: 7 contact miniature	220 1046 00
XV-20 XV-21	Socket for V-20, V-21	SOCKET, tube: 7 contact miniature	220 1034 00
XV-22	Socket for V-22	SOCKET, tube: 7 contact miniature	220 1046 00
XY-1	Socket for Y-1	SOCKET, crystal: crystal holders with .094 dia. pins spaced 500	292 0055 00
Y-1	Calibrator crystal	CRYSTAL: 100 KC	291 5954 00
Y-2	80 meter crystal	CRYSTAL: 5.7 mc	291 8070 00
Y-3	40 meter crystal	CRYSTAL: 9.3 mc	291 8071 00
Y-4	20 meter crystal	CRYSTAL: 16.5 mc	291 8072 00
Y-5	15 meter crystal	CRYSTAL: 23.0 mc	290 8439 00
Y-6	11 meter crystal	CRYSTAL: 29 mc	291 8076 00
Y-7	10 meter crystal	CRYSTAL: 30.5 mc	291 8077 00
Y-8	10 meter crystal	CRYSTAL: 31.5 mc	291 8078 00
70E-24	OSCILLATOR (VFO)	This unit has been dehydrated and hermetically sealed, and should be returned to the Collins Radio Company if servicing is required.	
455 J-05 (500 cps) 455 J-31 (3.1 kc) 455 J-60 (6.0 kc)	MECHANICAL FILTER	This unit has been dehydrated and hermetically sealed, and should be returned to the Collins Radio Company if servicing is required.	526 9154 00 526 9089 00 526 9091 00
	VERNIER TUNING KNOB		541 6291 001

