

Service Manual

FM-LW-MW-SW 1~9 12-Band Receiver

Radio
RF-B11

Colour

(K) : Black

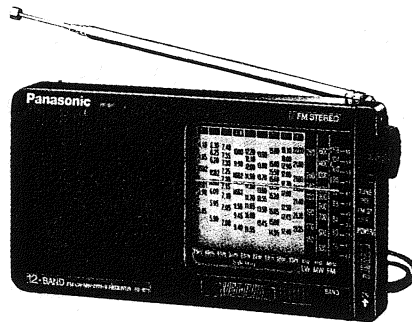

Areas

Suffix for Model No.	Area	Colour
(PP)	U.S.A. and Canada	(K)
(E)	Europe	
(GC)	Asia, Latin America, Middle East and Africa	
(GN)	Oceania	

Specifications

Frequency Range:

FM	(PP)(GC)(GN)...88.0 – 108.0 MHz (E)...87.5 – 108.0 MHz
MW	(PP)(E)(GN)...520 – 1610 kHz (GC)...530 – 1605 kHz
LW	(PP)(E)(GN)...148.5 – 285 kHz (GC)...150 – 285 kHz
SW1 (60 m)	4.75 – 5.06 MHz
SW2 (49 m)	5.95 – 6.20 MHz
SW3 (41 m)	7.10 – 7.30 MHz
SW4 (31 m)	9.50 – 9.90 MHz
SW5 (25 m)	11.65 – 12.05 MHz
SW6 (22 m)	13.60 – 13.80 MHz
SW7 (19 m)	15.10 – 15.60 MHz
SW8 (16 m)	17.55 – 17.90 MHz
SW9 (13 m)	21.45 – 21.75 MHz

Intermediate Frequency:

FM	10.7 MHz
AM (LW/MW/SW)	460 kHz

Sensitivity:

FM	8.9 μ V/ 5 mW SP output (30 dB)
MW	501 μ V/m/ 5 mW SP output (20 dB)
LW	1000 μ V/m/ 5 mW SP output (20 dB)
SW1	12.5 μ V/ 5 mW SP output (20 dB)
SW2	11.2 μ V/ 5 mW SP output (20 dB)
SW3	11.2 μ V/ 5 mW SP output (20 dB)
SW4	8.9 μ V/ 5 mW SP output (20 dB)
SW5	6.3 μ V/ 5 mW SP output (20 dB)
SW6	12.5 μ V/ 5 mW SP output (20 dB)
SW7	8.9 μ V/ 5 mW SP output (20 dB)
SW8	7.0 μ V/ 5 mW SP output (20 dB)
SW9	7.0 μ V/ 5 mW SP output (20 dB)

Power Requirement:

Battery	DC 3 V (two "AA" size, R6/LR6, UM-3 batteries)
AC	DC IN 3 V with optional Panasonic AC adaptor (RP-AC31)

Speaker:

8 cm PM dynamic speaker, 4 Ω

Output Power:

300 mW (RMS...max.)

Output Jack:

PHONES; \varnothing 3.5, 16 Ω

Dimensions:

174 (W) \times 92 (H) \times 33 (D) mm

Weight:

300 g (without batteries)

原本のため
持出厳禁

Notes:

1. Weight and dimensions shown are approximate.
2. Design and specifications are subject to change without notice.

WARNING

This service information is designed for experienced repair technicians only and is not designed for use by the general public. It does not contain warnings or cautions to advise non-technical individuals of potential dangers in attempting to service a product. Products powered by electricity should be serviced or repaired only by experienced professional technicians. Any attempt to service or repair the product or products dealt with in this service information by anyone else could result in serious injury or death.

Panasonic[®]

© 1995 Matsushita Electric Industrial Co., Ltd.
All rights reserved. Unauthorized copying and distribution is a violation of law.

Contents

	Page		Page
Location of Controls	2	Measurements and Adjustments	8, 9
Operation Check and Main Component Replacement Procedures	2 ~ 5	Replacement Parts List	10, 11, 13
Schematic Diagram	6	Cabinet Parts Location	12
Printed Circuit Board and Wiring Connection Diagram	7	Packaging	13

Location of Controls

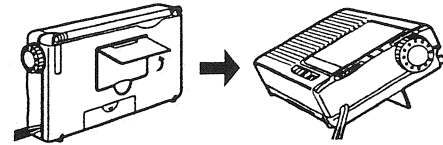
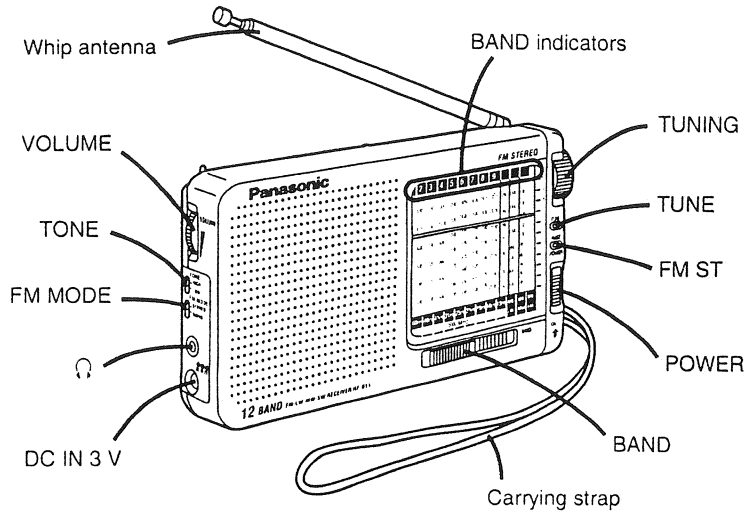

By using the stand, it is easy to operate.

BATTERY SERVICE LIFE

AA-size (UM-3) Batteries
 Approx. 30 hours of FM mode (EIAJ)
 Approx. 32 hours of AM mode (EIAJ)

The above battery service life is measured according to the conditions set forth by EIAJ (Electronic Industries Association of Japan). As the battery service life varies with the method of operation and environmental conditions, use these values as reference.

Operation Check and Main Component Replacement Procedures

- NOTE**
1. This section describes procedures for checking the operation of the major printed circuit boards and replacing the main components.
 2. For reassembly after operation checks or replacement, reverse the respective procedures. Special reassembly procedures are described only when required.
 3. Illustrated screws are equivalent to actual size.
 4. Refer the parts No. on the page of "Main Component Replacement Procedures", if necessary.

Checking and adjustment for P.C.B.

Step 3
 Release the 5 claws, and then remove the rear cabinet ass'y.

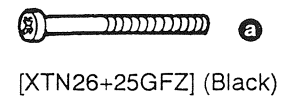
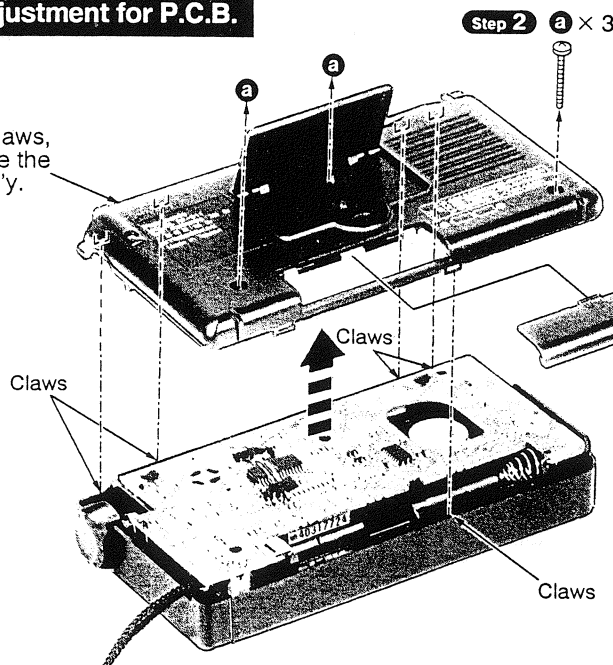

Step 1
 Remove the battery lid.

• Check the P.C.B. as shown below.

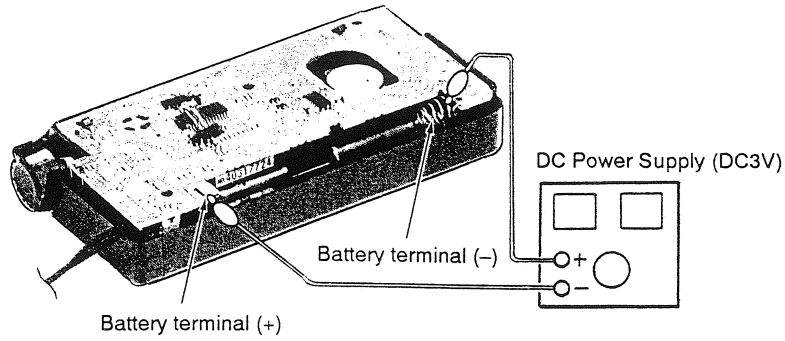

Step 4

Connect the DC power supply to battery terminals.

Step 6

Remove the P.C.B. and chassis from the front cabinet ass'y.

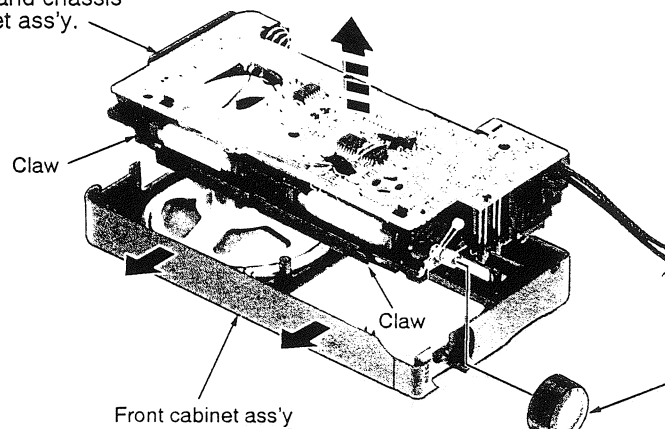

Step 5

Pull the selector knob.

※ When removing the chassis, spread the front cabinet ass'y in the direction of arrow so that the front cabinet ass'y is not hooked by claws.

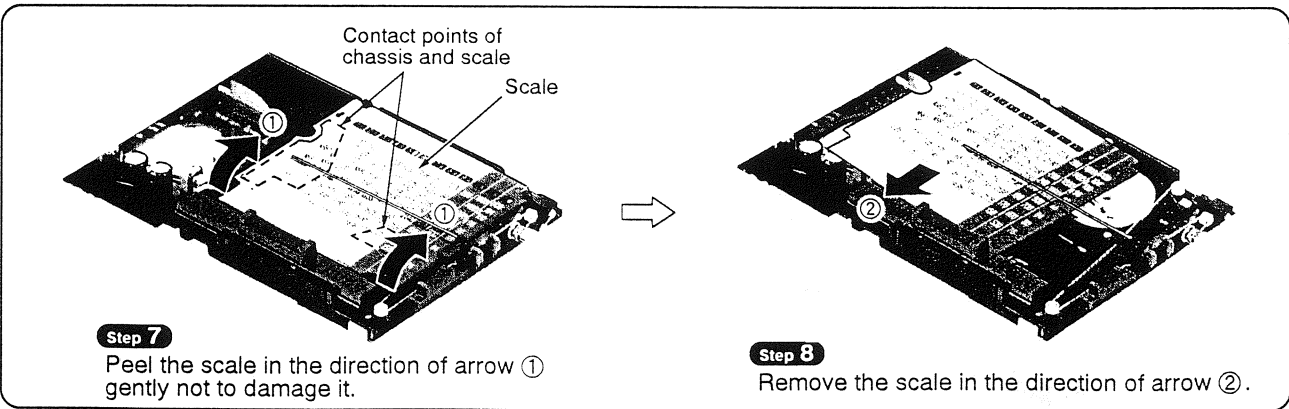

Step 7

Peel the scale in the direction of arrow ① gently not to damage it.

Step 8

Remove the scale in the direction of arrow ②.

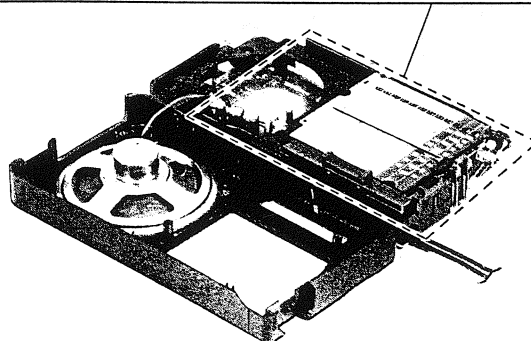

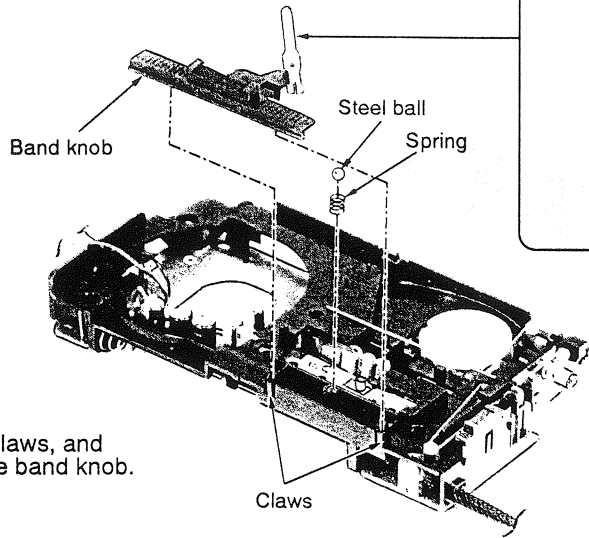

Step 9 Pull the indicator in the direction of arrow.

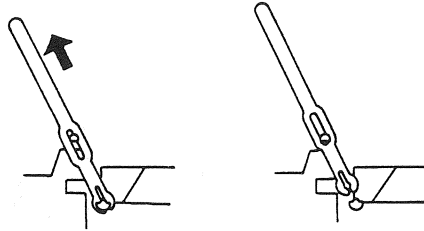

Step 10

Release the 2 claws, and then remove the band knob.

NOTE

Take care not to lose the steel ball and spring when removing the band knob.

Removal for speaker

- Remove the 3 screws, and then remove the brackets.

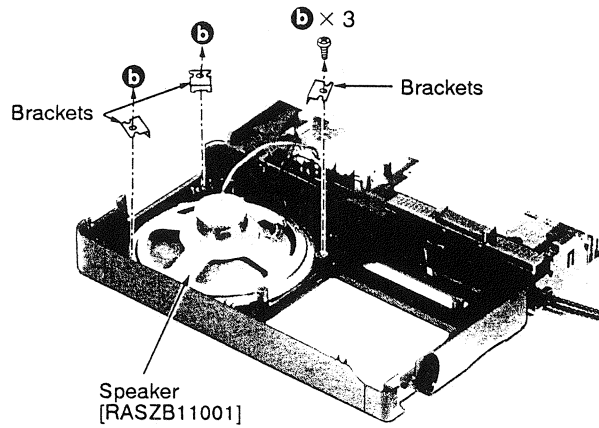

[XTN26+6]

- Check and adjust the P.C.B. as shown bellow.

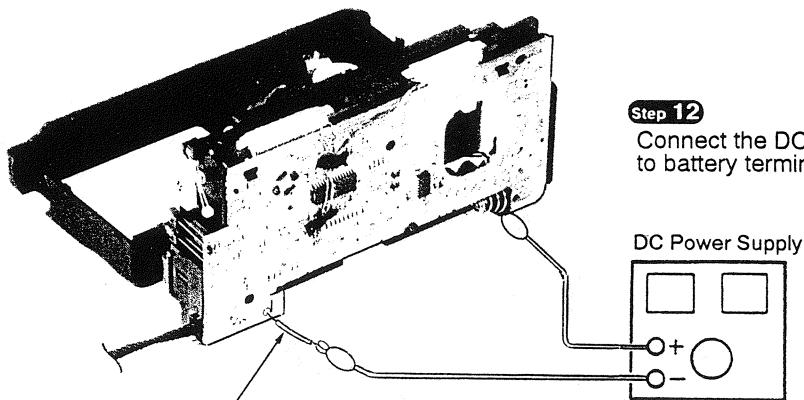

Step 12

Connect the DC power supply to battery terminals.

Step 11

Solder the lead wire with battery terminal.

Replacement for dial rope

■ Strapping for dial rope

Step 1

Hook the spring with the hole of dial drum.

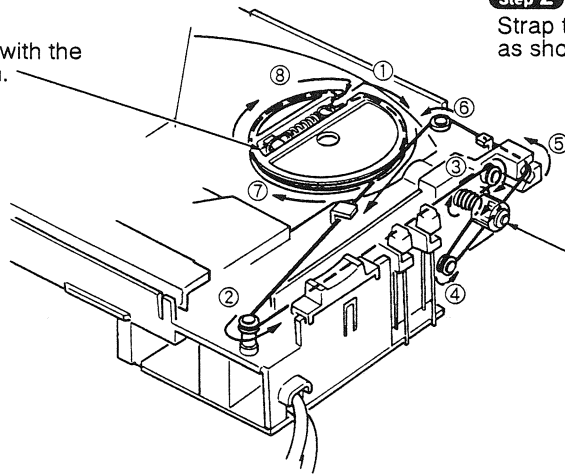

Step 2

Strap the dial rope in numerical order as shown below.

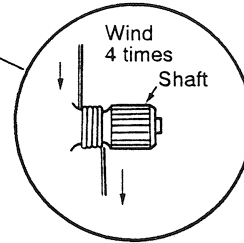

■ Installing for the pointer ("0" point adjustment)

Step 1

Rotate the dial drum fully in the direction of arrow.

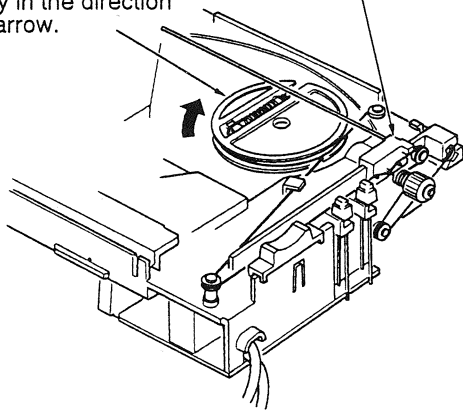

Step 2

Fix the pointer with dial pointer temporary.

Step 5

Set the pointer to marking.

Step 3

Install the scale.

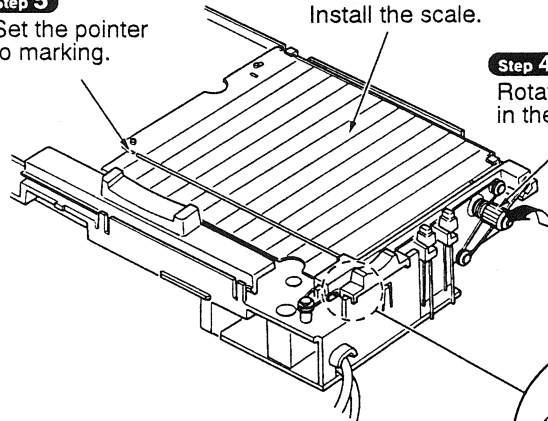

Step 4

Rotate the shaft fully in the direction of arrow.

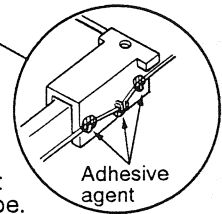

Step 6

Apply the adhesive agent to the pointer and dial rope.

Schematic Diagram

⇨ : FM Signal Line

⇨ : AM Signal Line

⇨ : + B Line

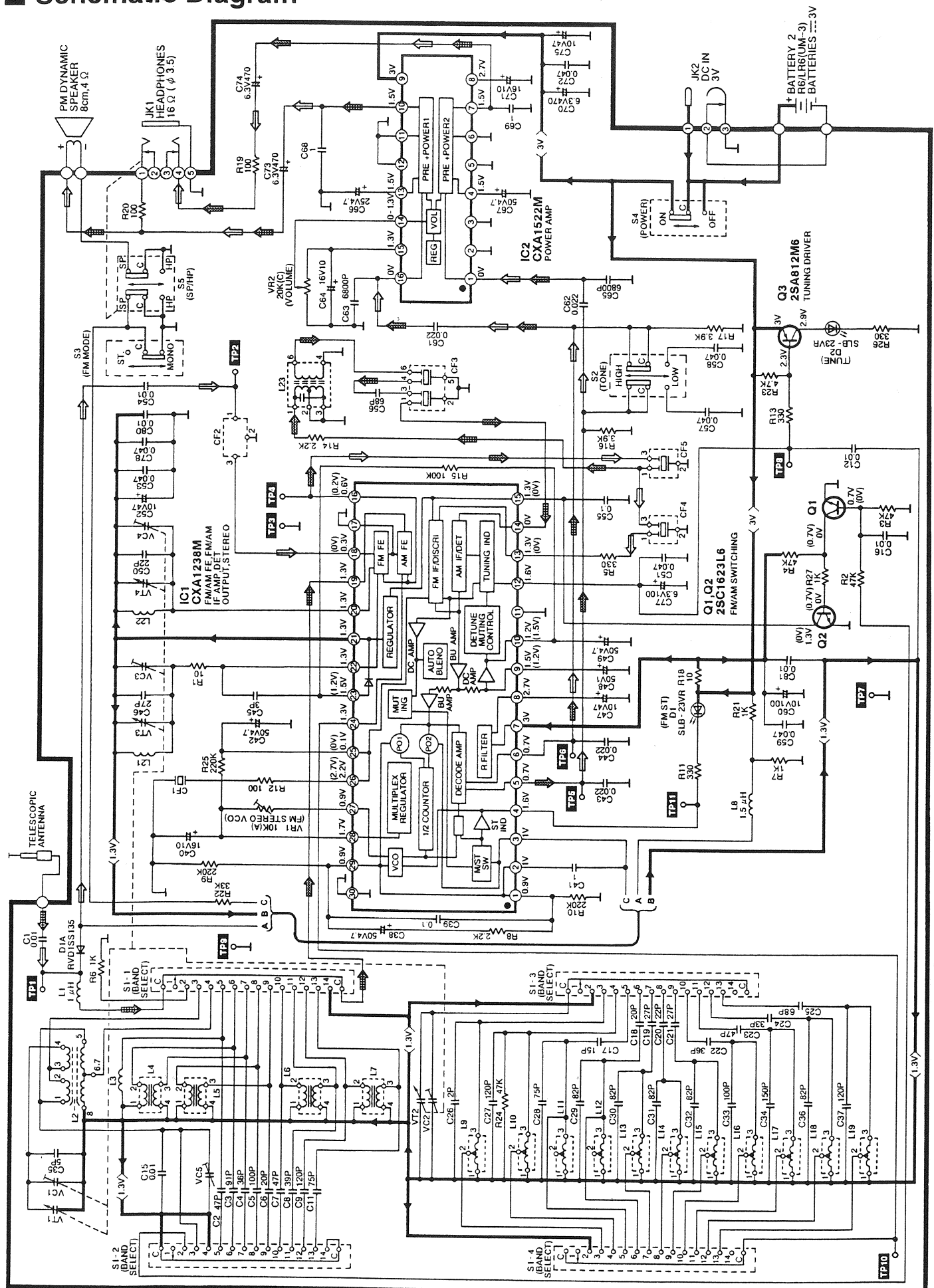

Printed Circuit Board and Wiring Connection Diagram

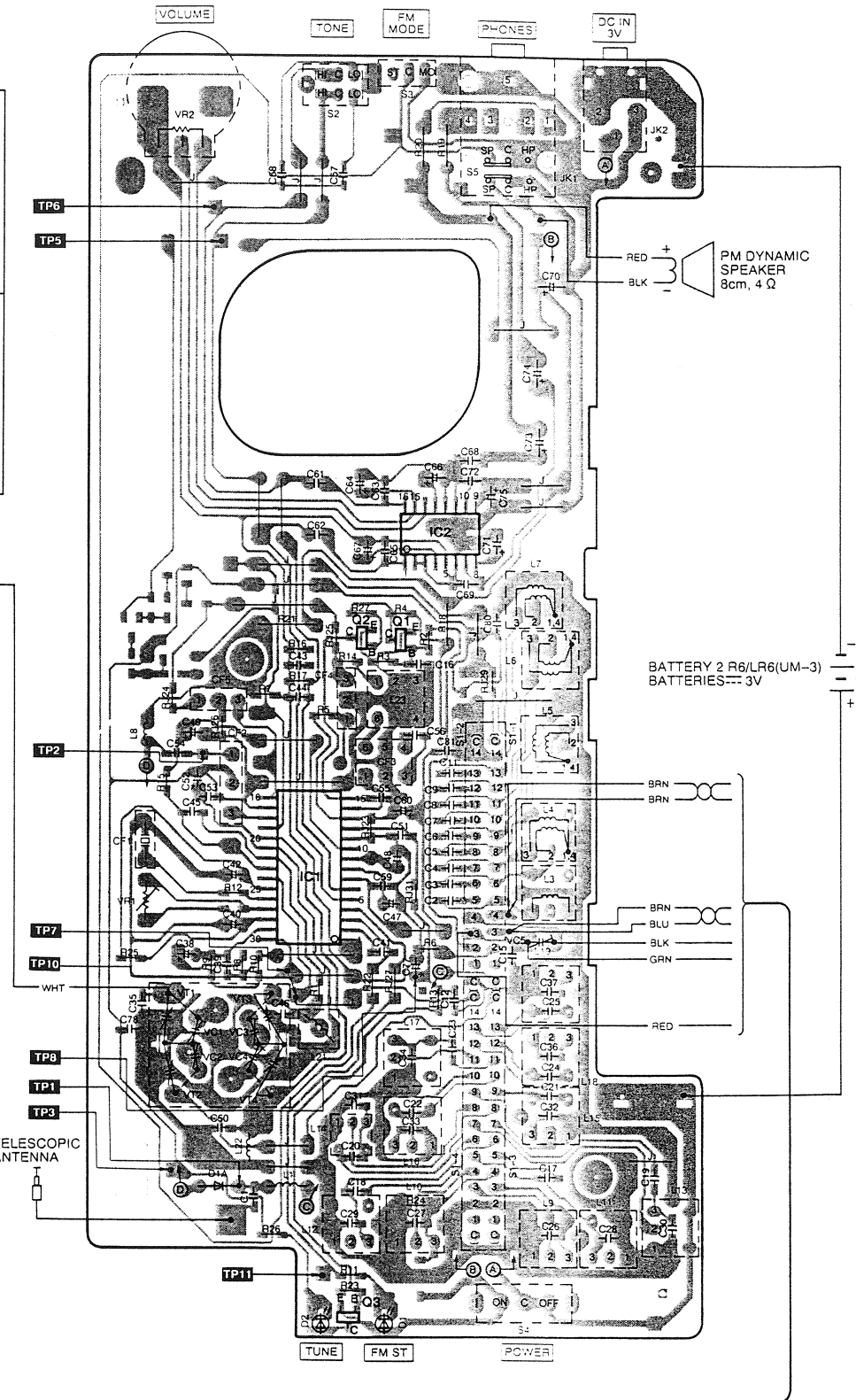
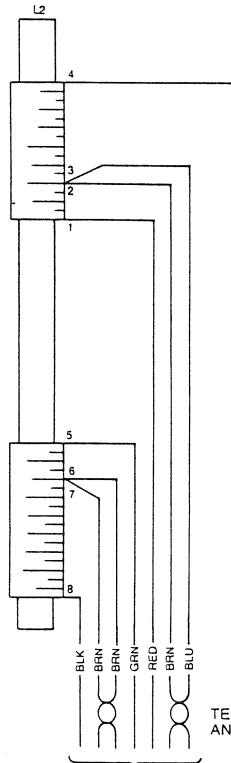
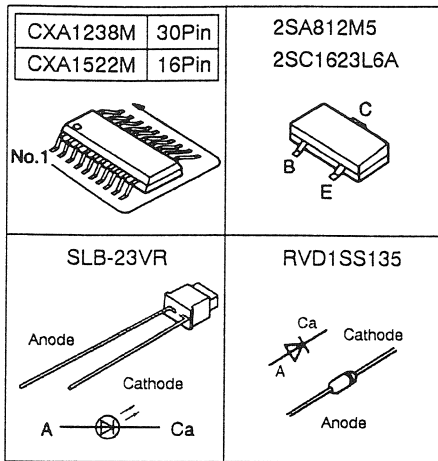

Notes:

- S1-1-S1-4 : Band select switch.
(1...No used, 2...FM, 3...MW, 4...LW, 5...SW9, 6...SW8, 7...SW7, 8...SW6, 9...SW5, 10...SW4, 11...SW3, 12...SW2, 13...SW1, 14...No used)
- S2 : Tone select switch.
- S3 : FM mode select switch.
- S4 : Power switch.
- S5 : Speaker/phones select switch.
- VR1 : FM stereo adjustment VR.
- VR2 : Volume control VR.
- Battery current:
Vol. min...14 mA (FM/AM) Vol. max...140 mA (FM/AM)
Measurement instruction
(AM (MW/LW/SW): 74 dB/m, 30% Mod.)
(FM: 60 dB, 30% Mod.)
- DC voltage measurements are taken with electronics voltmeter.
The negative terminal of the battery provides negative meter connection point.
()..... AM (MW/LW/SW) No mark..... FM
- This schematic diagram and printed circuit board diagram may be modified at any time with the development of new technology.

■ Measurements and Adjustments

● ALIGNMENT INSTRUCTION

READ CAREFULLY BEFORE ATTEMPTING ALIGNMENT

- Set power source voltage to 3 V DC.
- Set operation switch to ON.
- Set band select switch to FM, LW, MW or SW1-9.
- Set volume control to maximum.
- Output of signal generator should be no higher than necessary to obtain an output reading.

● FM ALIGNMENT

The parts other than the ones listed below are aligned at the factory before they are supplied. Therefore, alignment of those parts is unnecessary when used for replacement.

SIGNAL GENERATOR or SWEEP GENERATOR		RADIO DIAL SETTING	INDICATOR (ELECTRONIC VOLTMETER or OSCILLOSCOPE)	ADJUSTMENT (Refer to Fig.1 and Fig.2)	REMARKS
CONNECTIONS	FREQUENCY				
FM-RF ALIGNMENT					
(1)	Connect to test point TP2 through FM dummy antenna. Negative side to test point TP3 .	87.0MHz	Tuning capacitor fully closed.	Phones Jack (16 Ω) (Fabricate the plug as shown in Fig.3 and then connect the lead wires of the plug to the measuring instrument.)	L21 (FM OSC Coil) Adjust for maximum output.
(2)	"	109.0MHz	Tuning capacitor fully open.	"	VC3 (FM OSC Trimmer) "
(3)	"	90.0 MHz	Tune to signal	"	L22 (FM ANT Coil) "
(4)	"	106.0 MHz	"	"	VC4 (FM ANT Trimmer) 1. Adjust for maximum output. 2. Repeat steps (1) ~ (4).
FM STEREO ALIGNMENT					
(5)	"	90.0 MHz (90 dB, 0 % Mod.)	"	Connect to test point TP10 . Negative side to test point TP7 .	VR1 1. Set the volume control to minimum. 2. Adjust VR1 for 76.0 kHz ± 50 Hz reading on frequency counter.

● AM ALIGNMENT

SIGNAL GENERATOR or SWEEP GENERATOR		RADIO DIAL SETTING	INDICATOR (ELECTRONIC VOLTMETER or OSCILLOSCOPE)	ADJUSTMENT (Refer to Fig.1 and Fig.2)	REMARKS
CONNECTIONS	FREQUENCY				
AM-IF ALIGNMENT					
(6)	Connect to test point TP10 . Negative side to test point TP7 .	460 kHz	Point of non-interference. (on/about 600kHz)	Phones Jack (16 Ω) (Fabricate the plug as shown in Fig.3 and then connect the lead wires of the plug to the measuring instrument.)	L23 (AM IFT) Adjust for maximum output.
MW-RF ALIGNMENT					
(7)	Fashion a loop of several turns of wire and radiate a signal into the loop ant. of receiver.	515 kHz	Tuning capacitor fully closed.	"	L9 (MW OSC Coil) "
(8)	"	1650 kHz	Tuning capacitor fully open.	"	VC2 (MW OSC Trimmer) "
(9)	"	600 kHz	Tune to signal	"	(*1) L2 (MW ANT Coil) Adjust for maximum output. Adjust L2 by moving coil along the ferrite core.
(10)	"	1400 kHz	"	"	VC1 (MW ANT Trimmer) Adjust for maximum output. Repeat steps (7) ~ (10).
(*1) Fix antenna coil with wax after completing alignment.					
LW-RF ALIGNMENT					
(11)	"	140 kHz	Tuning capacitor fully closed.	"	L10 (LW OSC Coil) Adjust for maximum output.
(12)	"	170 kHz	Tune to signal	"	(*2) L2 (LW ANT Coil) Adjust for maximum output. Adjust L2 by moving coil along the ferrite core.
(13)	"	270 kHz	"	"	VC5 (LW ANT Trimmer) Adjust for maximum output. Repeat steps (11) ~ (13).
(*2) Fix antenna coil with wax after completing alignment.					

NOTE:

Before SW-RF alignment, be sure to prepare the following;

1. Set the output frequency of signal generator to 1000 kHz.
2. Turn the set to MW-band.
3. Adjust the tuning capacitor so that it receives 1000 kHz of output frequency and its output becomes maximum.
4. Fix tuning capacitor as this position, and make alignment of SW1 ~ SW9 on the following table.

	BAND	SIGNAL GENERATOR or SWEEP GENERATOR		INDICATOR (ELECTRONIC VOLTMETER or OSCILLOSCOPE)	ADJUSTMENT (Refer to Fig.1 and Fig.2)	REMARKS
		CONNECTIONS	FREQUENCY			
SW-RF ALIGNMENT						
(14)	SW1	Connect to test point TP1 through ceramic capacitor (0.001 μ F). Negative side to test point TP3	4.929 MHz	Phones Jack (16 Ω) Fabricate the plug as shown in Fig.3 and then connect the lead wires of the plug to the measuring instrument.	L7 (SW1 ANT Coil) L19 (SW1 OSC Coil)	Adjust for maximum output.
(15)	SW2	"	6.062 MHz	"	L18 (SW2 OSC Coil)	"
(16)	SW3	"	7.201 MHz	"	L6 (SW3 ANT Coil) L17 (SW3 OSC Coil)	"
(17)	SW4	"	9.677 MHz	"	L16 (SW4 OSC Coil)	"
(18)	SW5	"	11.827 MHz	"	L5 (SW5 ANT Coil) L15 (SW5 OSC Coil)	"
(19)	SW6	"	13.654 MHz	"	L14 (SW6 OSC Coil)	"
(20)	SW7	"	15.312 MHz	"	L4 (SW7 ANT Coil) L13 (SW7 OSC CIL)	"
(21)	SW8	"	17.665 MHz	"	L12 (SW8 OSC Coil)	"
(22)	SW9	"	21.561 MHz	"	L3 (SW9 ANT Coil) L11 (SW9 OSC Coil)	Adjust for maximum output. Repeat steps (14) ~ (22).

● **ALIGNMENT POINTS** (Please refer to Printed Circuit Board Diagram for test point locations.)

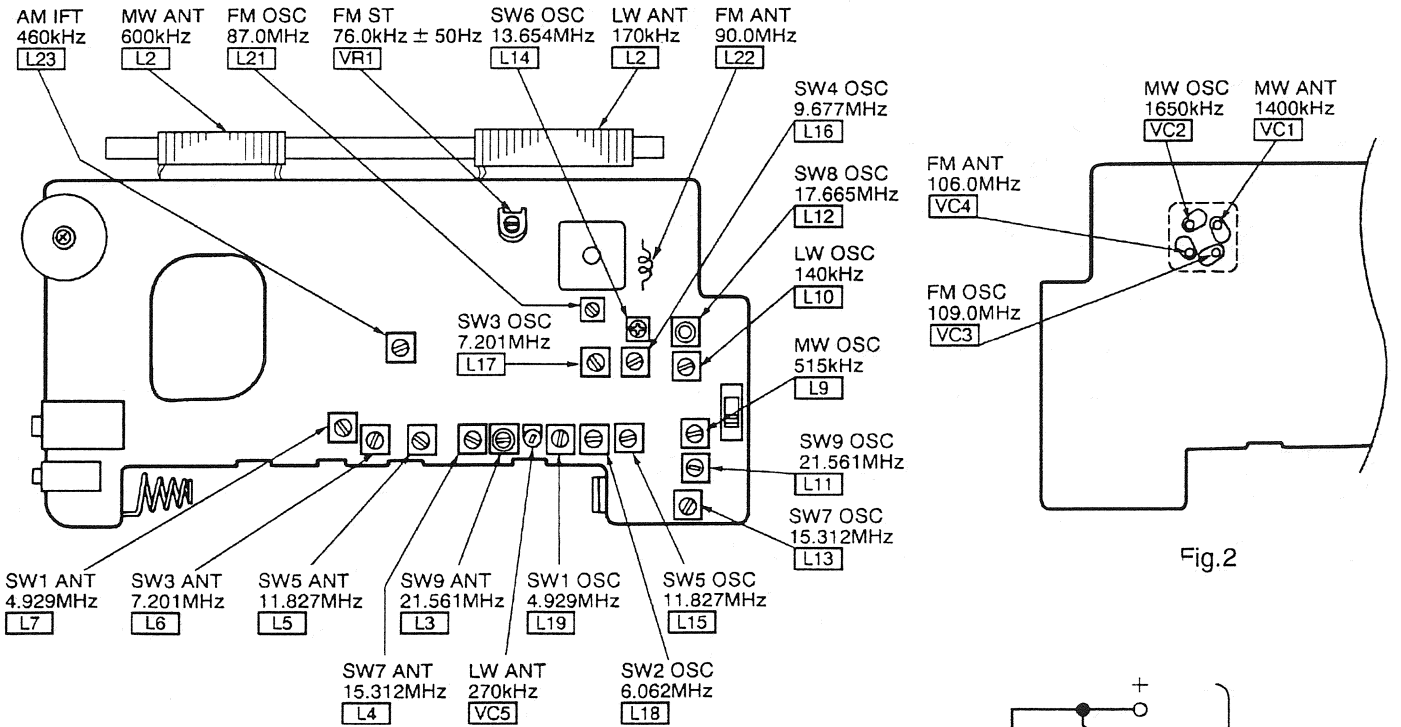

Fig.1

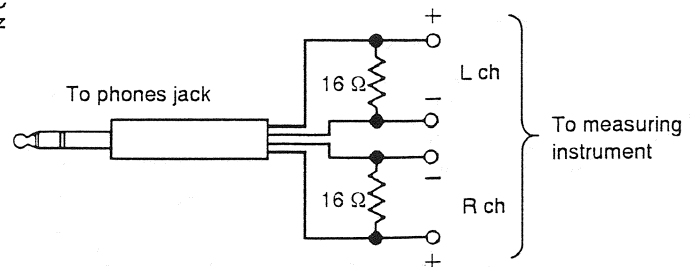

Fig.3

Replacement Parts List

Notes: *Important safety notice:

 Components identified by Δ mark have special characteristics important for safety.

Furthermore, special parts which have purposes of fire-retardant (resistors), high-quality sound (capacitors), low-noise (resistors), etc. are used.

When replacing any of components, be sure to use only manufacturer's specified parts shown in the parts list.

*The parenthesized indications in the Remarks columns specify the areas. (Refer to the cover page for area.)

Parts without these indications can be used for all areas.

* [M] Indicates in Remarks columns parts that are supplied by MESA.

* <VRD> indicates parts that are supplied by Video Recorder Division.

*The "(SF)" mark denotes the standard part.

Ref. No.	Part No.	Part Name & Description	Remarks	Ref. No.	Part No.	Part Name & Description	Remarks
		INTEGRATED CIRCUIT(S)		L17	RL0ZB11004	COIL	
				L18	RL0ZB11005	COIL	
				L19	RL0ZB11011	COIL	
IC1	CXA1238M	I. C, FM/AM FE, FM/AM IF AMP.		L21	RL0ZB11007	COIL	
IC2	CXA1522M	I. C, POWER AMP		L22	RL0ZB11013	COIL	
		TRANSISTOR(S)		L23	RL1ZB11001	COIL	
						FILTER(S)	
Q1	2SC1623L6A	TRANSISTOR		CF1	RLFZB11002	CERAMIC FILTER	
Q2	2SC1623L6A	TRANSISTOR		CF2	RCRZB11001	CERAMIC FILTER	
Q3	2SA812M5	TRANSISTOR		CF3	RLFZB11001	CERAMIC FILTER	
		DIODE(S)		CF4	RLFZB11003	CERAMIC FILTER	
				CF5	RLFZB11003	CERAMIC FILTER	
D1	SLB-23VR	LED				SWITCH(ES)	
D1A	RVD1SS135	DIODE					
D2	SLB-23VR	LED		S1	RSSZB11004	SW, BAND SELECT	
		VARIABLE RESISTOR(S)		S2	RSSZB11002	SW, TONE	
				S3	RSSZB11003	SW, FM MODE	
VR1	RRNZB11001	VR, VCO		S4	RSSZB11001	SW, POWER	
VR2	RRVZB11001	VR, VOLUME				JACK(S)	
		VARIABLE CAPACITOR(S)					
				JK1	RJJZB11001	HEADPHONES (S)	
VC1-4	RCVZB11001	VARIABLE CAPACITOR		JK2	RJJZB11002	DC IN	
VC5	RCVCTZ3120	VARIABLE CAPACITOR					
		COIL(S)					
L1	RLQZP180M-Y	COIL					
L2	RLVZB11001	COIL					
L3	RLAZB11002	COIL					
L4	RLAZB11005	COIL					
L5	RLAZB11001	COIL					
L6	RLAZB11003	COIL					
L7	RLAZB11004	COIL					
L8	RLQZB11001	COIL					
L9	RL0ZB11008	COIL					
L10	RL0ZB11001	COIL					
L11	RL0ZB11010	COIL					
L12	RL0ZB11012	COIL					
L13	RL0ZB11009	COIL					
L14	RL0ZB11006	COIL					
L15	RL0ZB11002	COIL					
L16	RL0ZB11003	COIL					

Notes : * Capacity values are in microfarads (uF) unless specified otherwise, P=Pico-farads (pF) F=Farads (F)
 * Resistance values are in ohms, unless specified otherwise, 1K=1,000(OHM) , 1M=1,000k(OHM)

Ref. No.	Part No.	Values & Remarks	Ref. No.	Part No.	Values & Remarks	Ref. No.	Part No.	Values & Remarks
		RESISTOR(S)	C7	ECUV1H470JCN	50V 47P	C59	ECUV1E473ZFN	25V 0.047U
			C8	ECUV1H390JCN	50V 39P	C60	ECEA1AU101	10V 100U
			C9	ECUV1H121JCN	50V 120P	C61	ECUV1E223KBN	25V 0.022U
R1	ERJ6GEYJ100	1/10W 10	C11	RCUZB11002	50V 75P	C62	ECUV1E223KBN	25V 0.022U
R2	ERJ6GEYJ473V	1/10W 47K	C12	ECUV1E103MBN	25V 0.01U	C63	ECUV1H682KBN	50V 6800P
R3	ERJ6GEYJ473V	1/10W 47K	C15	ECUV1E103MBN	25V 0.01U	C64	ECEA1CKA100B	16V 10U
R4	ERJ6GEYJ473V	1/10W 47K	C16	ECUV1E103MBN	25V 0.01U	C65	ECUV1H682KBN	50V 6800P
R5	ERJ6GEYJ331V	1/10W 330	C17	ECUV1H150JCN	50V 15P	C66	ECEA1EKA4R7	25V 4.7U
R6	ERJ6GEYJ102V	1/10W 1K	C18	ECUV1H200JCV	50V 20P	C67	ECEA1HJ4R7	50V 4.7U
R7	ERJ6GEYJ102V	1/10W 1K	C19	ECUV1H270JCN	50V 27P	C68	ECUV1C105ZFN	16V 1U
R8	ERJ6GEYJ222V	1/10W 2.2K	C20	ECUV1H220JCN	50V 22P	C69	ECUV1C105ZFN	16V 1U
R9	ERJ6GEYJ224V	1/10W 220K	C21	ECUV1H270JCN	50V 27P	C70	ECEAOJU471	6.3V 470U
R10	ERJ6GEYJ224V	1/10W 220K	C22	RCUZB11001	50V 36P	C71	ECEA1CU100	16V 10U
R11	ERJ6GEYJ331V	1/10W 330	C23	ECUV1H470JCN	50V 47P	C72	ECUV1E473ZFN	25V 0.047U
R12	ERJ6GEYJ101V	1/10W 100	C24	ECUV1H330JCN	50V 33P	C73	ECEAOJU471	6.3V 470U
R13	ERJ6GEYJ331V	1/10W 330	C25	ECUV1H680JCN	50V 68P	C74	ECEAOJU471	6.3V 470U
R14	ERJ6GEYJ222V	1/10W 2.2K	C26	ECUV1H020CCN	50V 2P	C75	ECEA1AU470	10V 47U
R15	ERJ6GEYJ104V	1/10W 100K	C27	ECUV1H121JCN	50V 120P	C77	ECEAOJKA101	6.3V 100U
R16	ERJ6GEYJ392V	1/10W 3.9K	C28	RCUZB11002	50V 75P	C78	ECUV1E473ZFN	25V 0.047U
R17	ERJ6GEYJ392V	1/10W 3.9K	C29	ECUV1H820JCN	50V 82P	C80	ECUV1E103MBN	25V 0.01U
R18	ERDS2TJ100	1/4W 10	C30	ECUV1H820JCN	50V 82P	C81	ECUV1E103MBN	25V 0.01U
R19	ERDS2TJ101	1/4W 100	C31	ECUV1H820JCN	50V 82P			
R20	ERDS2TJ101	1/4W 100	C32	ECUV1H820JCN	50V 82P			
R21	ERDS2TJ102	1/4W 1K	C33	ECUV1H101JCN	50V 100P			
R22	ERJ6GEYJ333V	1/10W 33K	C34	ECUV1H151JCN	50V 150P			
R23	ERJ6GEYJ472V	1/10W 4.7K	C35	ECUV1H050CCN	50V 5P			
R24	ERJ6GEYJ473V	1/10W 47K	C36	ECUV1H820JCN	50V 82P			
R25	ERJ6GEYJ224V	1/10W 222K	C37	ECUV1H121JCN	50V 120P			
R26	ERJ6GEYJ331V	1/10W 330	C38	ECEA1HJ4R7	50V 4.7U			
R27	ERJ6GEYJ102V	1/10W 1K	C39	ECUV1E104ZFN	25V 0.1U			
		CHIP JUMPER(S)	C40	ECEA1CU100	16V 10U			
			C41	ECUV1C105ZFN	16V 1U			
			C42	ECEA1HJ4R7	50V 4.7U			
RJ23	ERJ6GEYOR00V	1/10W 0	C43	ECUV1E223KBN	25V 0.022U			
RJ24	ERJ6GEYOR00V	1/10W 0	C44	ECUV1E223KBN	25V 0.022U			
RJ25	ERJ6GEYOR00V	1/10W 0	C45	ECUV1H030CCN	50V 3P			
RJ26	ERJ6GEYOR00V	1/10W 0	C46	ECUV1H270JCN	50V 27P			
RJ27	RRD18XK000-E	1/10W 0	C47	ECEA1AU470	10V 47U			
RJ29	ERJ6GEYOR00V	1/10W 0	C48	ECEA1HJ010	50V 1U			
RJ31	ERJ6GEYOR00V	1/10W 0	C49	ECEA1HJ4R7	50V 4.7U			
		CAPACITOR(S)	C50	ECUV1H220JCN	50V 22P			
			C51	ECUV1E473ZFN	25V 0.047U			
C1	ECUV1E103MBN	25V 0.01U	C52	ECEA1AU470	10V 47U			
C2	ECUV1H470JCN	50V 47P	C53	ECUV1E473ZFN	25V 0.047U			
C3	RCUZB11003	50V 91P	C54	ECUV1E103MBN	25V 0.01U			
C4	RCUZB11001	50V 36P	C55	ECUV1E104ZFN	25V 0.1U			
C5	ECUV1H101JCN	50V 100P	C56	ECUV1H680JCN	50V 68P			
C6	ECUV1H200JCV	50V 20P	C57	ECUV1E473KBN	25V 0.047U			
			C58	ECUV1E473KBN	25V 0.047U			

Cabinet Parts Location

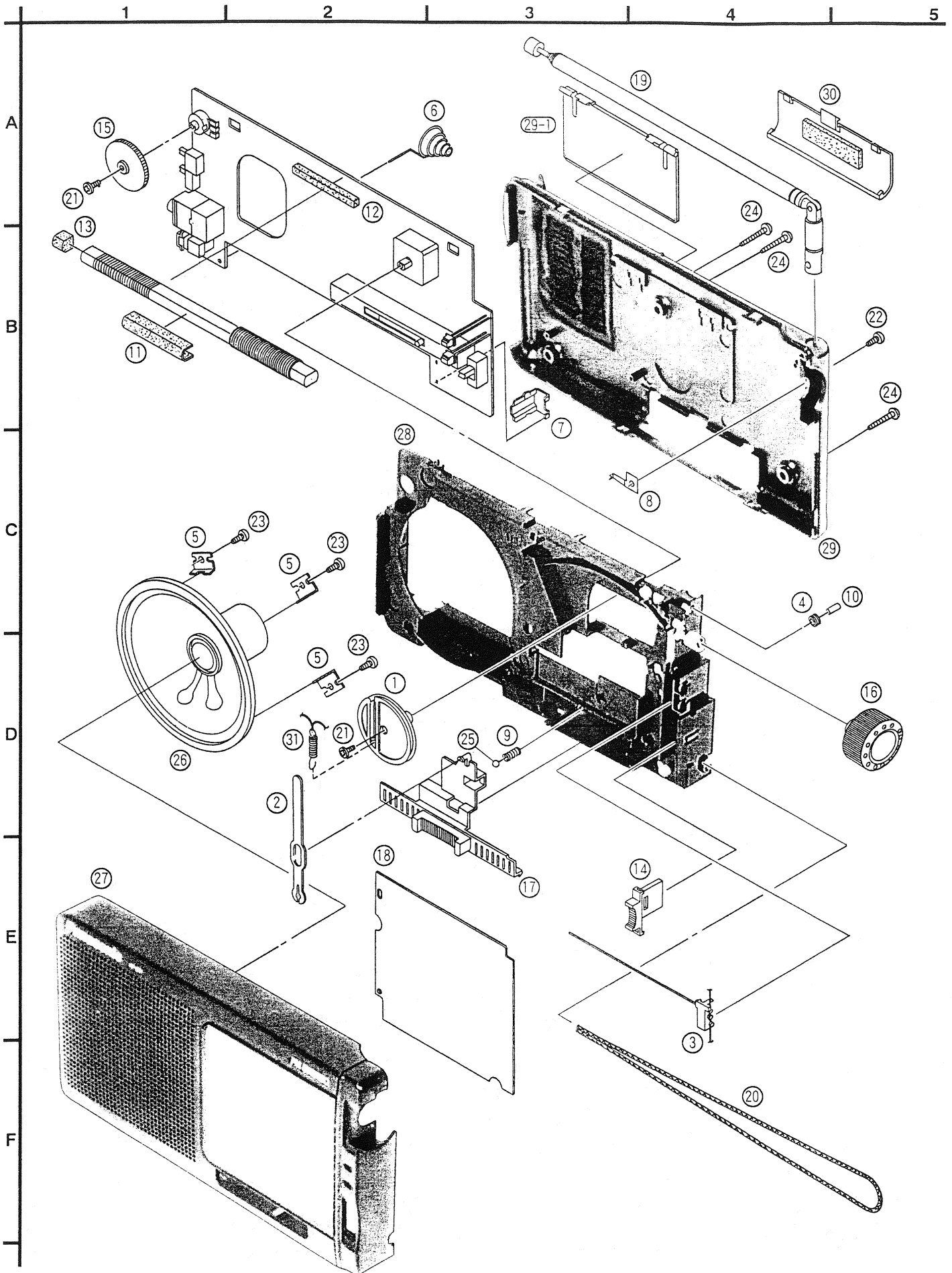

Ref. No.	Part No.	Part Name & Description	Remarks	Ref. No.	Part No.	Part Name & Description	Remarks
		CABINET PARTS		25	RDBZB11-001	STEEL BALL	
1	RDDZB11-001	DIAL DRUM		26	RASZB11001	SPEAKER	
2	RGKZB11-001	DIAL INDICATOR		27	RFKGF11E-K	FRONT CABINET ASS'Y	
3	RGJZB11-001	POINTER ASS'Y		28	RFKJFB11-K	DIAL	
4	RDPZB11-001	ROLLER		29	RFKHFB11E-K	REAR CABINET ASS'Y	(E)
5	RMAZB11-001	FIXER		29	RFKHFB11PP-K	REAR CABINET ASS'Y	(PP)
6	RJCZB11-001	BATT. TERMINAL (-)		29	RFKHFB11GC-K	REAR CABINET ASS'Y	(GC, GN)
7	RJCZB11-002	BATT. TERMINAL (+)		29-1	RFKNFB11-K	STAND	
8	RJHZB11-001	ANT. TERMINAL		30	RFKMF11-K	BATTERY COVER	
9	RMBZB11-001	SPRING		31	RFKNFB11-KA	DIAL CORD ASS'Y	
10	RMSZB11-002	SHAFT				PACKING MATERIALS	
11	RMXZB11-001	SPACER (1)		P1	RPK0705	GIFT BOX	(PP)
12	RMXZB11-002	SPACER (2)		P1	RPK0706	GIFT BOX	(E, GC, GN)
13	RMXZB11-004	SPACER (3)		P2	RPN0962	PAD	
14	RGVZB11-001	KNOB, POWER		P3	RPH0170	SHEET	
15	RGXZB11-001	KNOB, VOLUME				ACCESSORIES	
16	RGWZB11-001	KNOB, TUNING		A1	RQT3130-E	INST. MANUAL	(E)
17	RGVZB11-002	KNOB, BAND		A1	RQT3131-G	INST. MANUAL	(GC, GN)
18	RKDZB11-002	DIAL SCALE	(PP, E)	A1	RQT3129-P	INST. MANUAL	(P)
18	RKDZB11-003	DIAL SCALE	(GC, GN)				
19	XEAZB11-001	TELESCOPIC ANTENNA					
20	RFCZB11-001	STRAP					
21	XQN17+C4	SCREW					
22	XSN26+5FZ	SCREW					
23	XTN26+6	SCREW					
24	RFKNFB11NA	SCREW					

■ Packaging

