

## Errata

**Title & Document Type:** 428B Clip-On DC Milliammeter  
**Manual Part Number:** 00428-90003  
**Serial Prefixes:** 995  
**Revision Date:** Circa November 1970

### HP References in this Manual

This manual may contain references to HP or Hewlett-Packard. Please note that Hewlett-Packard's former test and measurement, semiconductor products and chemical analysis businesses are now part of Agilent Technologies.

### Changes to this Manual

No changes have been made to this manual, with the exception of correcting the odd spelling and grammatical errors. In some places original photographs may be replaced or augmented with modern digital photographs. All pages are scan at 600 DPI and in some cases (schematics) scaled down to fit an 8½x11 page with no loss in resolution (I just change the DPI to 1200 or above).

If you wish to print on 11x17 or larger just print the page and scale it to fit the paper size.

### About this Manual

This manual is reproduced from scans of an original document, which is then converted using my own custom designed OCR software, and then edited in Microsoft® Word 2003.

This means that what you see here is NOT a scan of a scan/copy with text overlays. The only images in this document are the pictures, schematics and front cover.

OCR errors may exist and as such the user of this document should take care and use common sense when referencing this documentation.

### Copyright Notice

This documentation is copyrighted by Hewlett Packard and Jack Hudler, hpdocs@hudler.org.

Permission to use and redistribute this documentation for non-commercial and internal corporate purposes is hereby granted, free of charge.

Any redistribution of this documentation or its derivatives must include this copyright notice.

You **may not** sell this documentation or its derivations without written consent.

You may modify this documentation as necessary, but you may not sell derivative works based on it.

You may include this documentation with the equipment/hardware on which it is used for the purposes of selling the equipment/hardware. If you advertise that a copy of this documentation is included in the sale, you must state that is for "Free".

Meaning if you want to gratuitously toss in a copy of the manual on an eBay sale, it's ok with me as long as you state it's for free. No you can't sell a digital archive of manuals and say it includes a free copy of this documentation. You must give it away with equipment.

I think you get the spirit of the copyright; it takes a lot of hours to scan and replicate a manual. I just want this used in the spirit in which is it given.

Agilent if you have questions or wish to include this in your archive, please contact me.

*Page intentionally left blank.*

OPERATING AND SERVICE MANUAL

# CLIP ON DC MILLIAMMETER 428B



HEWLETT  PACKARD

## CERTIFICATION

*The Hewlett-Packard Company certifies that this instrument was thoroughly tested and inspected and found to meet its published specifications when it was shipped from the factory. The Hewlett-Packard Company further certifies that its calibration measurements are traceable to the U.S. National Bureau of Standards to the extent allowed by the Bureau's calibration facility.*

## WARRANTY AND ASSISTANCE

All Hewlett-Packard products are warranted against defects in materials and workmanship. This warranty applies for one year from the date of delivery, or, in the case of certain major components listed in the operating manual, for the specified period. We will repair or replace products which prove to be defective during the warranty period provided they are returned to Hewlett-Packard. No other warranty is expressed or implied. We are not liable for consequential damages.

Service contracts or customer assistance agreements are available for Hewlett-Packard products that require maintenance and repair on-site.

For any assistance, contact your nearest Hewlett-Packard Sales and Service Office. Addresses are provided at the back of this manual.



## OPERATING AND SERVICE MANUAL

-hp- Part No. 00428-90003

# MODEL 428B CLIP-ON DC MILLIAMMETER

**Serials Prefixed: 995- and above**  
Appendix A, Manual Backdating Changes  
adapts this manual to instruments with  
earlier serial prefixes.

Copyright Hewlett-Packard  
Company 1970 P.O. Box 301,  
Loveland, Colorado, 80537 U.S.A.

Printed: NOV 1970

## TABLE OF CONTENTS

<b>GENERAL INFORMATION</b>	<b>2</b>	<b>MAINTENANCE</b>	<b>14</b>
1-1. INTRODUCTION	2	5-1. INTRODUCTION.	14
1-7. INSTRUMENT AND MANUAL IDENTIFICATION.	2	5-3. TEST EQUIPMENT REQUIRED.	14
	3	5-5. IN-CABINET PERFORMANCE CHECKS.	14
<b>INSTALLATION</b>	<b>3</b>	5-7. CLEANING OF PROBE JAWS.	14
2-1. UNPACKING AND MECHANICAL INSPECTION.	3	5-10. ELECTRICAL ZERO SET.	14
	3	5-13. RANGE CHECK.	15
2-4. OPERATION CHECK.	3	5-15. METER TRACKING.	15
2-6. INSTALLATION.	3	5-17. OUTPUT CALIBRATION.	15
2-8. POWER REQUIREMENTS.	3	5-19. FREQUENCY RESPONSE.	15
2-10. OPERATION ON 115 OR 230 VOLTS.	3	5-21. AC OVERLOAD.	16
2-13. THREE CONDUCTOR POWER CABLE.	3	5-23. NOISE CHECK.	16
2-15. RACK MOUNT MODEL.	3	5-25. ADJUSTMENT PROCEDURE.	16
2-17. PREPARATION FOR STORAGE AND SHIPMENT.	3	5-27. POWER SUPPLY.	16
	3	5-29. MECHANICAL ZERO SET.	16
2-20. STORAGE.	3	5-31. DC AMPLIFIER BALANCE.	16
<b>OPERATING INSTRUCTIONS</b>	<b>5</b>	5-34. ALIGNMENT.	17
3-1. INTRODUCTION.	5	5-35. OSCILLATOR BALANCE.	17
3-3 OPERATING PRECAUTIONS.	5	5-37. OSCILLATOR FREQUENCY.	17
3-4. OPERATING CONSIDERATIONS.	5	5-39. OSCILLATOR LEVEL.	17
3-5. INTERCHANGING PROBE HEADS.	5	5-41. DETECTOR GATE.	17
3-7. EFFECT OF MEASUREMENT ON CIRCUIT.	5	5-43. TUNED AMPLIFIER.	17
3-12. EFFECT OF CIRCUIT ON MEASUREMENT.	5	5-44. Equipment Setup.	17
3-19. Magnetic Fields.	6	5-46. Input Alignment.	17
3-26. OPERATING PRACTICES.	6	5-48. Interstage Alignment.	17
3-27. MECHANICAL OPERATION OF PROBE.	6	5-50. DETECTOR PHASE ADJUSTMENT.	17
3-29. DEGAUSSING OF PROBE HEAD.	6	5-53. Preliminary Adjustment.	18
3-33. ELECTRICAL ZERO SET.	6	5-54. Preset the controls as follows:	18
3-37. POLARITY OF CURRENT.	6	5-55. Drive Balance Adjustment.	18
3-39. INCREASING THE ABSOLUTE SENSITIVITY	7	5-59. TROUBLESHOOTING.	19
3-41. CURRENT CHECK LOOPS.	7	5-60. FRONT PANEL TROUBLESHOOTING.	19
3-44. NULLING CURRENTS.	7	5-63. DETAILED TROUBLESHOOTING.	19
3-46. USE OF OUTPUT JACK.	7	5-64. Probe Check.	19
3-48. With Oscilloscope.	7	5-66. Power Supply Check.	19
3-50. With Recorder.	7	5-71. Oscillator - Buffer Amp. Check.	21
<b>THEORY OF OPERATION</b>	<b>9</b>	5-80. Synchronous Detector.	21
4-1. INTRODUCTION.	9	<b>REPLACEABLE PARTS</b>	<b>23</b>
4-3. THEORY OF OPERATION.	9	6-1. INTRODUCTION.	23
4-9. CURRENT PROBE.	9	6-4. ORDERING INFORMATION.	23
4-19. 20 kHz OSCILLATOR.	11	6-6. NON-LISTED PARTS.	23
4-23. HEAD-DRIVE AMPLIFIER.	11	<b>CIRCUIT DIAGRAMS</b>	<b>29</b>
4-25. DETECTOR GATE AMPLIFIER.	11	7-1. INTRODUCTION.	29
4-28. 40 kHz INPUT/AMPLIFIER CIRCUIT.	11	7-3. BLOCK DIAGRAM.	29
4-30. SYNCHRONOUS DETECTOR AND FILTER (C24).	11	7-5. SCHEMATIC DIAGRAMS.	29
	11	7-7. COMPONENT LOCATION DIAGRAMS.	29
4-36. DC AMPLIFIER.	12	<b>MANUAL BACKDATING CHANGES</b>	<b>36</b>
4-43. NEGATIVE FEEDBACK CURRENT CIRCUIT.	12		
4-45. 40 kHz PHASE SHIFTER.	12		
4-48. POWER SUPPLY.	12		

## LIST OF TABLES

Table 1-1. Specifications	1	Table 6-1. Replaceable Parts	24
Table 5-1. Recommended Test Equipment.	13		

## LIST OF ILLUSTRATIONS

Figure 1-1. Model 428B Clip-On Milliammeter	2	Figure 5-7. Detector Phase Display.	18
Figure 3-1. Measurement Procedures	4	Figure 5-9. Detailed Troubleshooting Tree.	20
Figure 3-2. Polarity of Current.	6	Figure 6-1. Parts Breakdown, current probe.	28
Figure 3-3. Increasing The Absolute Sensitivity.	7	Figure 7-1. Block Diagram.	30
Figure 4-1. Block Diagram	8	Figure 7-2. Component Locator For Circuit Board Part	
Figure 4-2. Simplified Block.	9	No. 00428-66501	31
Figure 4-3. Magnetic Mechanical Analogy.	10	Figure 7-3. Front Panel Component Locator.	31
Figure 4-5. 428B Flux Gate.	10	Figure 7-4 Rear Panel Component Locator.	31
Figure 4-4. Basic Flux Gate.	10	Figure 7-5. Power Supply.	32
Figure 4-6. Waveforms.	10	Figure 7-6. Block Diagram.	33
Figure 4-7. Detector Bridge.	11	Figure 7-7. Component Locator for Circuit Board Part	
Figure 4-8. Negative Feedback	12	No. 00428-66501	34
Figure 4-9. 90° Phase Shift	12	Figure 7-8. Front Panel Component Locator.	34
Figure 5-1. Cleaning Probe Jaws.	14	Figure 7-9 Rear Panel Component Locator.	34
Figure 5-2. Electrical Zero Set.	14	Figure 7-10. Metering Circuit	35
Figure 5-3. Range Check.	15	Figure A-1. 428B Side Views.	37
Figure 5-4. AC Overload.	16	Figure A-2 Backdating Schematics for 428B	38
Figure 5-5. Oscillator Balance Probe.	17	Figure A-3 Backdating Schematics for 428B	39
Figure 5-6. Detector Phase Adjustment.	17		

## 428B SPECIFICATIONS

Table 1-1 Specifications

**Current Range:**

1 mA to 10 A full-scale, nine ranges.

**Accuracy:**

± 3% of full-scale ± 0.15 mA, from 0°C to 55°C.  
(When instrument is calibrated to probe).

**Probe Inductance:**

Less than 0.5 µH.

**Probe Induced Voltage:**

Less than 15 mV peak (worst case at 20 kHz and harmonics).

**Output:**

Variable linear output level with switch position for calibrated 1 V into open circuit (corresponds to full-scale deflection). 1.5 V Max. into open circuit in uncalibrated position.  
0.73 ± .01 V into 1 kΩ in calibrated position.

**Noise:**

1 mA Range, < 15 mV rms across 1 kΩ.  
3 mA Range, < 5 mV rms across 1 kΩ.  
10 mA thru 10 A Ranges, < 2 mV rms across 1 kΩ.

**Frequency Range:**

DC to 400 Hz (3 dB point).

**AC Rejection:**

Signals above 5 Hz with peak value less than full-scale affect meter accuracy less than 2%. (Except at 40 kHz carrier frequency and its harmonics). On the 10 A range, ac peak value is limited to 4 A.

**Probe Insulation:**

300 V Max.

**AC Power:**

115 or 230 V ±10%, 50 to 60 Hz, 71 W.

**Operating Temperature:**

- 20°C to + 55°C.

**Cabinet Mount:**

7½" wide, 11½" high, 14½" deep (190,5 x 292,1 x 368,3 mm).

**Weight:**

Cabinet Mount: Net 19 lbs (8,6 kg);  
shipping 24 lbs (10,9 kg).

Rack Mount: Net 24 lbs (10,9 kg); shipping  
35 lbs 15,9 kg).

**Accessories Available:**

- hp- Model 3528A Large Aperture Probe
- hp- Model 3529A Magnetometer Probe
- hp- Model 11035A Output Cable
- hp- Model 10110A Output Adapter

**Dimensions:**

Rack Mount

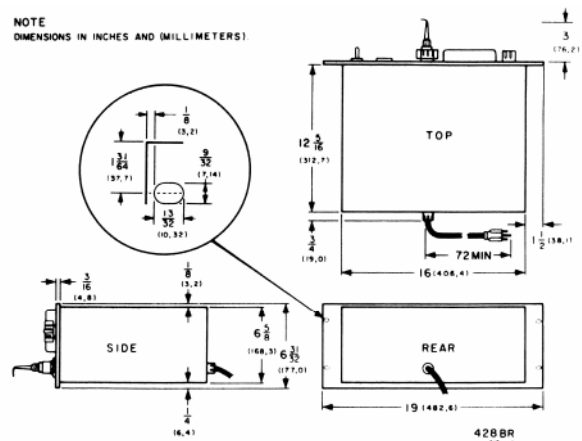

**Probe Tip**

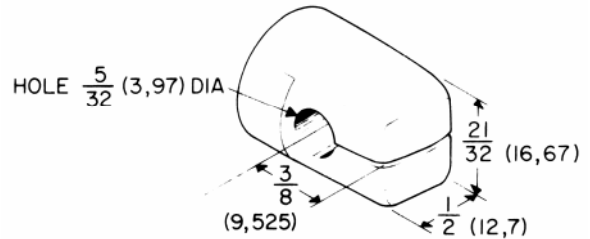



## SECTION I

### GENERAL INFORMATION

#### 1-1. INTRODUCTION

1-2. The -hp- Model 428B Clip-On Milliammeter measures the magnetic field, which exists around the wire carrying dc current. Operating the instrument is simple. After zero setting, the two jaws of the probe are clamped around wire (arrow on probe head indicates direction of conventional current flow) and the meter will indicate the current.

1-3. There are nine current ranges starting from 1 mA to 10 amp full-scale deflection. The sensitivity can be increased even further by looping the wire several times through the opening in the probe. The current indication is virtually insensitive to superimposed ac signals and the series loading of the circuit is less than 0.5 pH. A large amount of feedback provides great stability.

#### 1-4. OTHER PROBE HEADS.

1-5. Other probe heads are available to extend the usefulness of your Clip-On DC Milliammeter. Write to the nearest Sales and Service Office (listed in Appendix C) for further information. At the time of publication of this manual, the following accessory probe heads were available:

- a. -hp- Model 3528A Large Aperture (2-1/2 inch probe head).
- b. -hp- Model 3529A Magnetometer (1 gauss = 1 amp).
- c. -hp- Model C11-3529A Magnetometer (1 gauss = 1 mA).

1-6. Write to the nearest Sales and Service Office (listed in Appendix C) stating your complete requirements for information concerning special applications.

#### 1-7. INSTRUMENT AND MANUAL IDENTIFICATION.

1-8. Hewlett-Packard uses a two-section serial number. If the first section (serial prefix) of the serial number on your instrument does not agree with those on the title page of this manual, change sheets supplied with the manual will define the differences between your instrument and the Model 428B described in this manual. Some serial numbers may have a letter separating the two sections of the number. This letter indicates the country in which the instrument was manufactured.

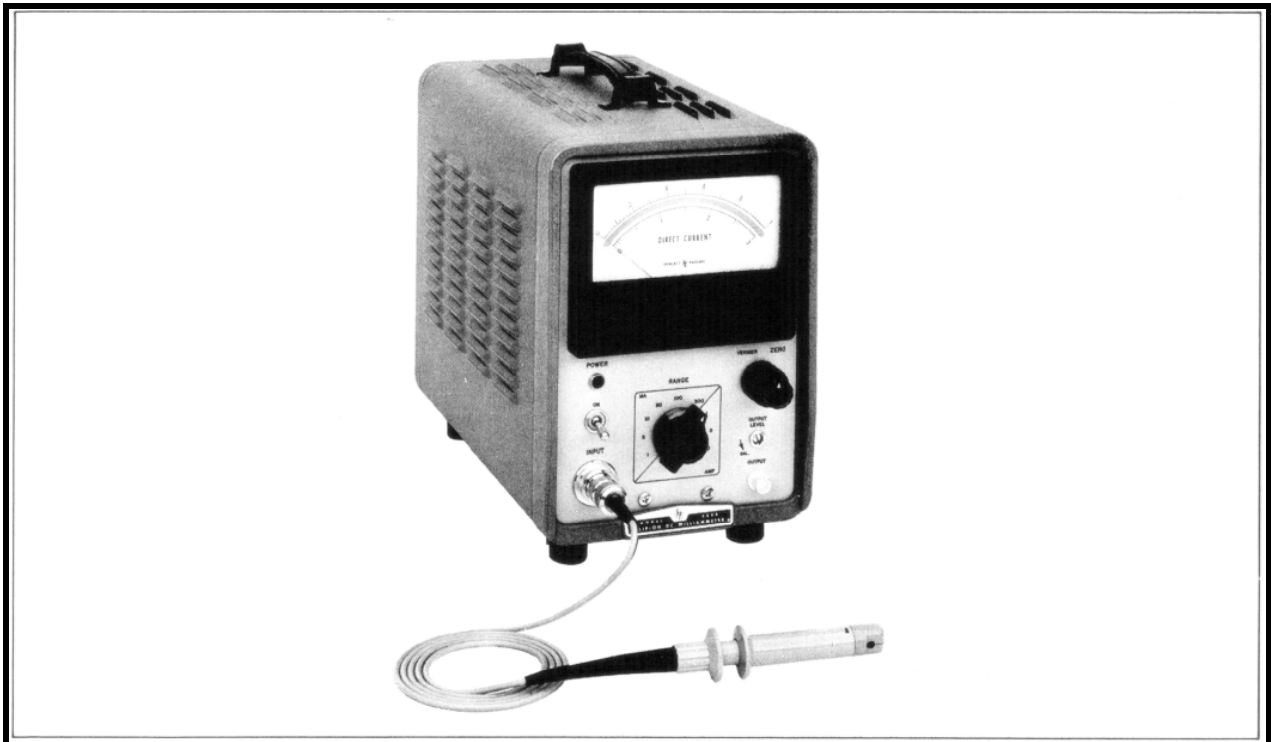

Figure 1-1. Model 428B Clip-On Milliammeter

## SECTION II

### INSTALLATION

#### **2-1. UNPACKING AND MECHANICAL INSPECTION.**

2-2. Inspect instrument for signs of damage incurred in shipment. This instrument should be tested as soon as it is received. If it fails to operate properly, or is damaged in any way, a claim should be filed with the carrier. A full report of the damage should be obtained by the claim agent, and this report should be forwarded to us. We will then advise you of the disposition to be made of the equipment and arrange for repair or replacement. Include model number and serial number when referring to this instrument for any reason.

2-3. Hewlett-Packard Company warrants each instrument manufactured by them to be free from defects in material and workmanship. Our liability under this warranty is limited to servicing or adjusting any instrument returned to the factory for that purpose and to replace any defective parts thereof. Any damage to the instrument upon receipt is due to the carrier. File a claim with the carrier as instructed in the preceding paragraph.

#### **2-4. OPERATION CHECK.**

2-5. This instrument should be checked as soon as it is received to determine that its electrical characteristics have not been damaged in shipment. Refer to the In-Cabinet Performance Checks of Section V of this manual.

#### **2-6. INSTALLATION.**

2-7. See Paragraph 3-3 before operating this instrument.

#### **2-8. POWER REQUIREMENTS.**

2-9. Power requirements are given in Specifications table at the front of this manual.

#### **2-10. OPERATION ON 115 OR 230 VOLTS.**

2-11. This instrument may be used with either a 115 volt or 230 volt supply with a frequency of 50 to 60 cps, single phase. This instrument is shipped from the factory ready for operation from a 115 volt source unless otherwise indicated.

2-12. To operate from a 230 volt source, the 115-230 switch on the rear apron must be flipped to 230. First turn the instrument off and pull the power cable from the socket. Place a pointed tool, such as the sharpened end of a pencil, in the slot of the switch and pull down. Replace the fuse with the one given in Table 6-1 for 230 volt operation.

#### **2-13. THREE CONDUCTOR POWER CABLE.**

2-14. The three-conductor power cable supplied with the instrument is terminated in a polarized, three-prong male connector recommended by the National Electrical Manufacturers' Association (NEMA). The third conductor grounds the instrument chassis for the PROTECTION OF THE OPERATING PERSONNEL. When using a three-prong to two-prong adapter ground third lead (green wire) externally.

#### **2-15. RACK MOUNT MODEL.**

2-16. This instrument is available in a rack mount version in addition to the cabinet model shown in this manual. The rack mount version is identical electrically and similar physically except that the degausser has been moved to the front panel for greater convenience.

#### **2-17. PREPARATION FOR STORAGE AND SHIPMENT.**

2-18. The best method for packing this instrument is in the original shipping carton with the original fillers packed in the same manner as when received from the factory. Therefore, when unpacking, note carefully the method of packing and save the original packing material for possible future reuse.

2-19. If the original packing material is not available, and it is desired to package the instrument for storage or shipment, first wrap the instrument in heavy kraft paper to avoid scratching the paint. Then pack in a cardboard carton with a bursting strength of at least 150 lb per square inch. Pad the instrument on all sides with at least 2 inches of rubberized hair or at least 4 inches of tightly packed excelsior.

#### **2-20. STORAGE.**

2-21. No special precautions are necessary in storage except the usual protection against mechanical damage, salt air, etc.

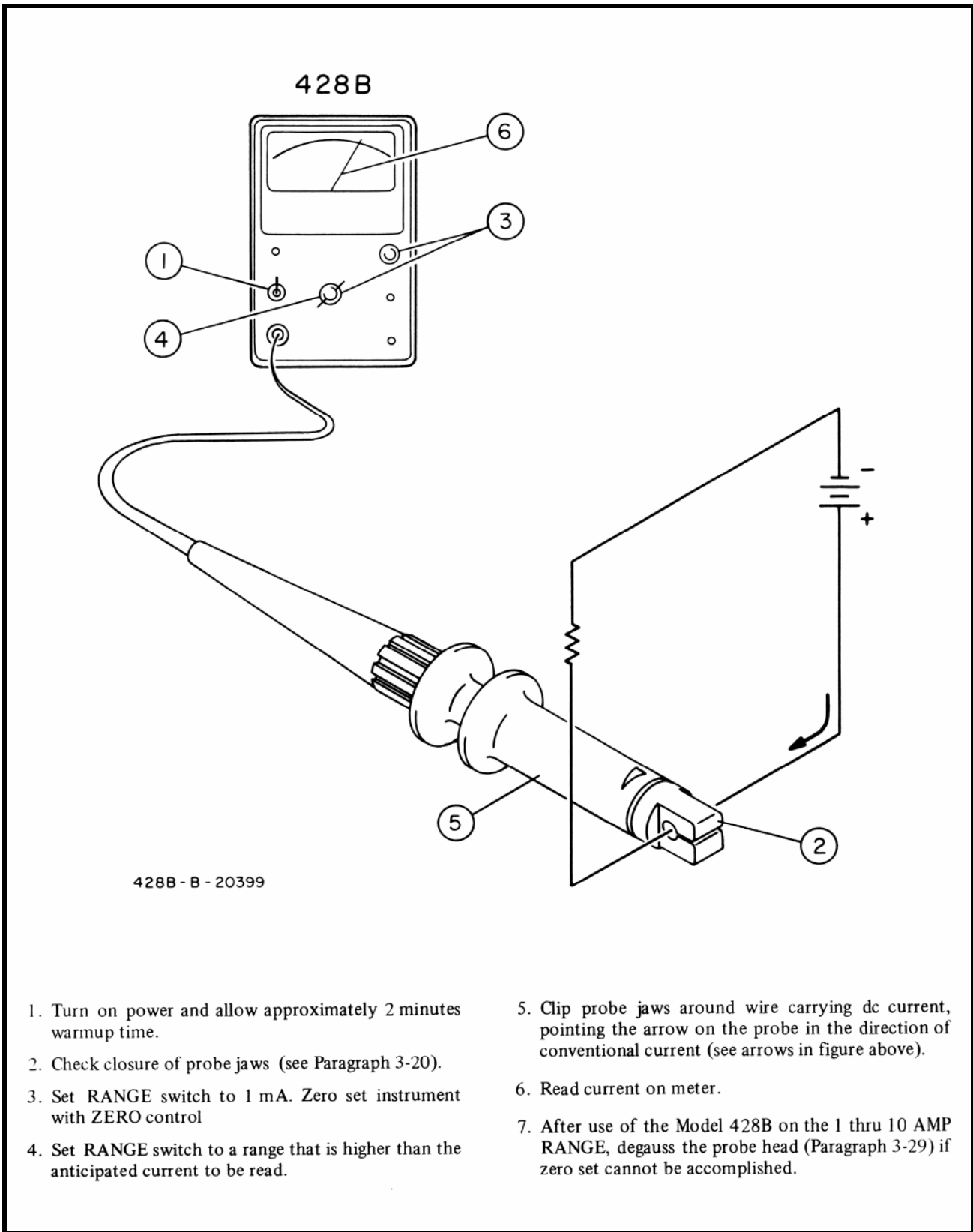

Figure 3-1. Measurement Procedures

## SECTION III

### OPERATING INSTRUCTIONS

#### 3-1. INTRODUCTION.

3-2. This section contains instructions and information necessary for operation of the Model 428B clip-on milliammeter.

#### 3-3 OPERATING PRECAUTIONS.

##### CAUTION

- a. BEFORE APPLYING OPERATING POWER TO THE 428B, VERIFY THAT THE LINE VOLTAGE SWITCH ON THE REAR PANEL INDICATES THE LINE VOLTAGE TO BE USED AND THAT THE INSTRUMENT IS PROPERLY FUSED.
- b. THE PROBE IS INSULATED TO WITHSTAND 300 VOLTS MAXIMUM. DO NOT USE THIS PROBE ON A BARE WIRE WHICH IS MORE THAN 300 VOLTS PEAK ABOVE GROUND.
- c. DO NOT USE THE 428B PROBE IN THE PRESENCE OF STRONG RF FIELDS.
- d. DO NOT EXPOSE THE 428B PROBE TO TEMPERATURES EXCEEDING 130° F (55°C). DO NOT LAY THE PROBE ON TOP OF THE 428B CABINET (OR ANY OTHER HOT SURFACE). PROBE UNBALANCE AND EVENTUAL DAMAGE WILL RESULT.
- e. DO NOT DROP THE PROBE OR RELEASE THE FLANGES ABRUPTLY SO THAT THE JAWS SNAP TOGETHER.
- f. DO NOT OPERATE THE DEGAUSSER FOR MORE THAN THREE MINUTES CONTINUOUSLY.
- g. BECAUSE THE 428B IS COOLED BY "CONVECTION" PLACE THE 428B WHERE AIR CAN CIRCULATE FREELY THROUGH THE INSTRUMENT.
- h. DO NOT USE THE 428B TO MEASURE DC IN A WIRE WHICH CARRIES MORE AC THAN FULL-SCALE READING ON THE METER.

#### 3-4. OPERATING CONSIDERATIONS.

#### 3-5. INTERCHANGING PROBE HEADS.

3-6. Each probe is calibrated at the factory with a particular instrument and carries the serial number of that instrument (**serial number appears on probe connector**) (NOTE: if your buying one with the probe, make sure you verify this. The numbers are scribed with a vibrating pen. Not very HP). If a probe has to be replaced, a realignment and recalibration of the instrument is necessary (see also Section V Maintenance).

#### 3-7. EFFECT OF MEASUREMENT ON CIRCUIT.

3-8. Reflected Impedance.

3-9. The probe will add a small inductance to the circuit of less than 0.5 microhenries due to the magnetic core and magnetic shield. This makes it ideal for measuring current in very low impedance paths such as ground loops where other instruments would disturb the circuit.

3-10. Induced Voltage.

3-11. The gating signal, driving the core in and out of saturation, will induce a voltage in the wire carrying the dc current. This induced voltage is less than 15 millivolts peak. If more than one loop is passed through the probe the induced voltage will be multiplied by the number of loops.

#### 3-12. EFFECT OF CIRCUIT ON MEASUREMENT.

3-13. Circuit Impedance.

3-14. The impedance of the circuit being measured has practically no effect on the dc current measurement. A shorted loop inserted along with a wire carrying dc current will decrease the reading by only 0.2% of full scale.

3-15. AC Fields & Superimposed AC Current.

3-16. The instrument is designed to allow a high amount of ac ripple in the dc being measured. The presence of ac whose peak value equals full-scale reading (limited to 4 amperes peak on 10-ampere range) will cause less than 2% error in the dc reading. Examples of such high ac currents are found in the input of dc filter sections of power supplies.

3-17. Ac currents having frequency components of 40 kHz or harmonics thereof will cause error, as such signals will interfere with the 40 kHz output signal of the probe. The meter will indicate a beat reading if the interfering frequency is within approximately 15 cycles of 40 kHz or its harmonics. Although this situation is very improbable, accurate dc current readings can be obtained by shifting the frequency of the external ac signal slightly.

3-18. The instrument as well as the probe head should not be used in strong ac stray fields. Such fields may exist in the vicinity of open core power transformers, or large dc filter chokes, etc.

**3-19. Magnetic Fields.**

3-20. If the jaws of the probe are incompletely closed, the magnetic shielding and the magnetic circuit will have an air gap. The result is that dc fields, not associated with the dc current being measured, will cause a shift in the meter reading.

3-21. However, there will be an indication of a strong external dc field even with the jaws perfectly closed. Usually zero setting with the ZERO control compensates such residual readings for a particular probe location.

3-22. EARTH'S MAGNETIC FIELD. The earth's magnetic field will affect the reading if the jaws of the probe are not completely shielded (jaws partially open). The effect of this field is relatively strong - comparable to deflection due to about 500 mA of current. Complete closure of the jaws can be checked by switching to the 1 mA range with no dc current input. If the jaws mate properly, the zero set should stay within 0.1 mA while rotating the probe head with respect to the earth's magnetic field.

3-23. If the zero shift is greater, the mating surfaces of the jaws need to be cleaned or the probe wiring may be open (see Section V).

3-24. FIELDS OF PERMANENT MAGNETS. Meter magnets have strong stray fields, which can cause shift in the current indication. Such fields are detected by bringing the closed probe in the area where the measurement is to be made and observing the zero shift (1 mA range).

3-25. FERROUS WIRE. Wires made out of magnetic materials can cause a current reading of 2-3 mA without any connection to the wire. This fact is important as leads of most transistors are made out of magnetic material.

**3-26. OPERATING PRACTICES.**

**3-27. MECHANICAL OPERATION OF PROBE.**

3-28. The probe jaws are opened by simply squeezing together the two flanges on the probe body. An internal spring returns the jaws to their proper position when the flanges are released. (See Paragraph 3-3e.)

**3-29. DEGAUSSING OF PROBE HEAD.**

3-30. To demagnetize the probe, proceed as follows:

- a. Insert probe into degausser at the rear of the instrument (located on front panel of rackmount models) with arrow on probe in same position as arrow marked on chassis.
  - b. Depress degausser switch S3 to energize degausser.
  - c. Withdraw probe very slowly for the first few inches while depressing the degausser switch until probe is removed approximately one foot.
  - d. Zero instrument on 1 mA range with ZERO control
- 3-31. Under normal operating conditions, degaussing

may be necessary after measuring current on the 1 thru 10 AMP RANGE.

3-32. Normally, it takes about 10 seconds to degauss the probe when using the above method (see Caution, Paragraph 3-3f).

**3-33. ELECTRICAL ZERO SET.**

3-34. If the instrument cannot be zero set electrically (with ZERO control) there are two probable causes:

- 1) Incomplete closure of probe jaws, 2) Magnetization of probe head.

3-35. Dust deposits on the lapped surfaces of the probe jaws create an air gap. If the jaws are not completely closed, the earth's magnetic field will affect the reading. With the RANGE switch at 1 mA, rotation of the closed probe should not vary the zero set more than 0.1 mA. Cleaning of the jaws will restore proper operation conditions (see Section V, Cleaning of Probe Jaws).

3-36. Magnetic shields protect the probe head from stray magnetic fields. However, excessive dc currents (such as short circuit discharge currents from electrolytic capacitors, etc.) will magnetize the probe. For demagnetization of probe head, see Paragraph 3-29, Degaussing of Probe Head.

**3-37. POLARITY OF CURRENT.**

3-38. The arrow on the probe head indicates the direction of the conventional current flow for upscale reading. Reversal of the current flow direction will reverse the indication on the meter (see Figure 3-2).

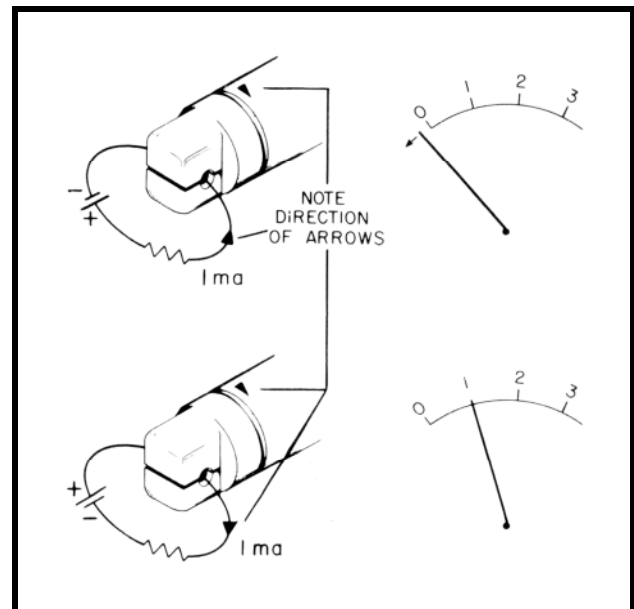

**Figure 3-2. Polarity of Current.**

### 3-39. INCREASING THE ABSOLUTE SENSITIVITY

3-40. The sensitivity of the instrument can be increased by looping the wire (carrying the dc current) several time through the opening of the probe (see Figure 3-3). For example, three turns increase the sensitivity three times. With an increased sensitivity, however, the induced voltage between the probe and the circuit under measurement will increase also.

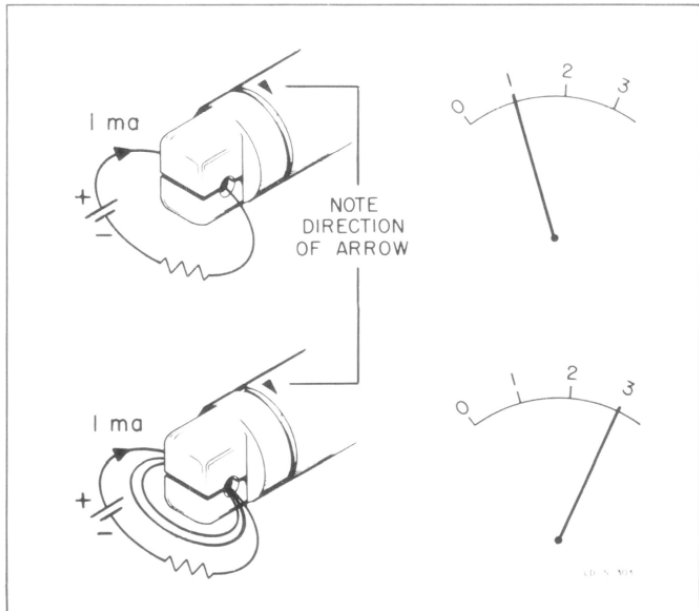

Figure 3-3. Increasing The Absolute Sensitivity.

### 3-41. CURRENT CHECK LOOPS.

3-42. In restricted situations such as printed circuit boards, wire loops for the probe can be built into the circuit to allow convenient current measurements with the Model 428B. Here, currents can then be measured under operating conditions with the same ease as voltage measurement.

3-43. Circuits can also be modified to accept an impromptu loop for testing. As an example, to measure the collector current of a transistor for troubleshooting purposes, the collector lead can be removed from the board and a loop of fine wire soldered between the collector lead and the board. To measure current through a resistor, lift one lead and install a series loop, clip the 428B probe around the loop and measure current through the resistor. As an alternative, an equivalent resistor with long leads can be installed to replace the resistor in question.

### 3-44. NULLING CURRENTS.

3-45. The resolution of the 428B can be increased by nulling one current against another and measuring the difference between the two. To null the reading, clip the probe over both wires at once with the wires so arranged that the currents are going in opposite directions. The considerations mentioned in Paragraph 3-39 also apply to current nulling. For example, assume that a 0.6 A current source is to be tested against a 0.4 A standard. The 0.6 A supply should be looped twice through the probe jaws and the 0.4 A supply should be looped three times through the jaws such that the

two currents oppose each other. It should be remembered when making such a measurement, that the absolute value of any deviations observed have been multiplied. If, in the above example, the 0.6 A supply wavered by .01 A, the change would be read as .02 A on the meter.

### 3-46. USE OF OUTPUT JACK.

3-47. The OUTPUT jack enables the 428B to be used as a dc coupled: amplifier/I-E transducer /isolator. The basic action of the 428B (considered as an input/output device) is to sense the magnetic field around a current carrying wire and deliver a proportional voltage at the OUTPUT jack. The value of the output can be varied by using the OUTPUT LEVEL control to produce as much as 1 1/2 volts at 1 mA. While the 428B meter registers average dc (ignoring ac), the output at the OUTPUT jack contains both the dc and ac components of the signal being measured.

### 3-48. With Oscilloscope.

3-49. To display the output of the 428B on an oscilloscope:

- If the oscilloscope is dc coupled, it can be calibrated as in Paragraph 3-51.
- Clip the probe around the wire which varies the signal to be displayed.
- Connect the oscilloscope input to the 428B OUTPUT jack.
- Adjust the 428B RANGE switch to the appropriate range.

### 3-50. With Recorder.

3-51. To record the output of the 428B on a graphic recorder:

- Insure that the recorder's input impedance exceeds 1400 ohms.
- Connect the recorder input to the 428B OUTPUT jack.
- Zero the 428B on the 1 mA Range, turn OUTPUT LEVEL to minimum output.
- Zero the recorder.
- Adjust the 428B ZERO control for full-scale on the 428B meter.
- Adjust the 428B OUTPUT LEVEL control for full scale on the recorder.
- Zero the 428B, switch to the appropriate range and clamp the 428B probe around the wire which carries the signal to be measured.

3-52. When recording current variations with the 428B, it should be borne in mind that the 428B displays some long term zero drift. The 428B zero drift normally amounts to about 300  $\mu$ A (indicated) per day so periodic checks should be made to determine whether or not the ZERO controls need adjustment.

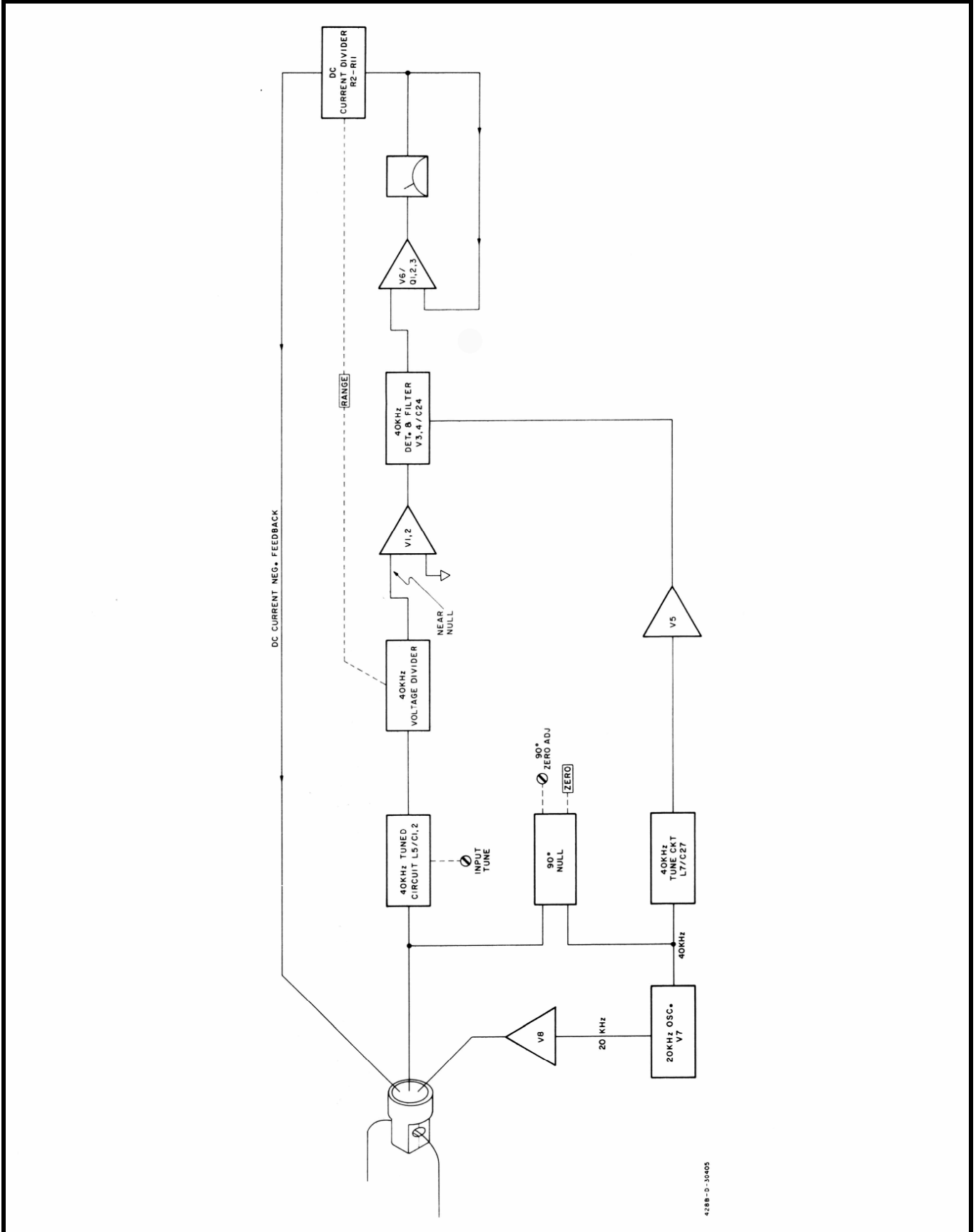

428B-D-10405

Figure 4-1. Block Diagram

## SECTION IV

### THEORY OF OPERATION

#### 4-1. INTRODUCTION.

4-2. This section describes the overall operation of the Model 428B, the operating principle of the current probe and the function of the different circuits of the instrument.

#### 4-3. THEORY OF OPERATION.

4-4. The simplified block diagram of Figure 4-2 shows the basic operation of the Model 428B Clip-ON Milliammeter.

4-5. The probe clips around a wire carrying dc current and delivers a 40 kHz output signal which is proportional to the dc current. For transducing the dc current into a 40 kHz signal, the probe requires a 20 kHz gating signal, as described in detail under Paragraph 4-9, Current probe.

4-6. The 40 kHz output signal of the probe is amplified, detected and fed back as negative feedback current to the probe head cancelling the effect of the measured dc current and thus reducing the 40 kHz output signal almost to zero. The negative feedback current, being proportional to and magnetically almost equal to the dc current of the inserted wire, is used to indicate the measured dc current.

4-7. The 20 kHz oscillator has two functions: First, it supplies a 20 kHz signal for driving the probe head, and also provides a 40 kHz (second harmonic) signal for gating the 40 kHz Synchronous Detector.

4-8. Due to slight unbalances, the probe head output contains a small 40 kHz signal, even with no dc current being measured. A 40 kHz phase-shifter output cancels such residual 40 kHz signal (zero-set controls).

#### 4-9. CURRENT PROBE.

4-10. The probe head is a specially designed second harmonic flux gate type of a magnetometer used to measure the magnetic field around a wire carrying direct current.

4-11. The flux gate principle is easily understood by referring to the mechanical model shown in Figure 4-3.

4-12. Coil A (representing wire through probe), is energized with dc, producing a dc flux in the core. Armature is rotating at a constant rate (F), gating the flux 2F times per second inducing a voltage of 2 F frequency in coil B. The amplitude is determined by the dc in coil A.

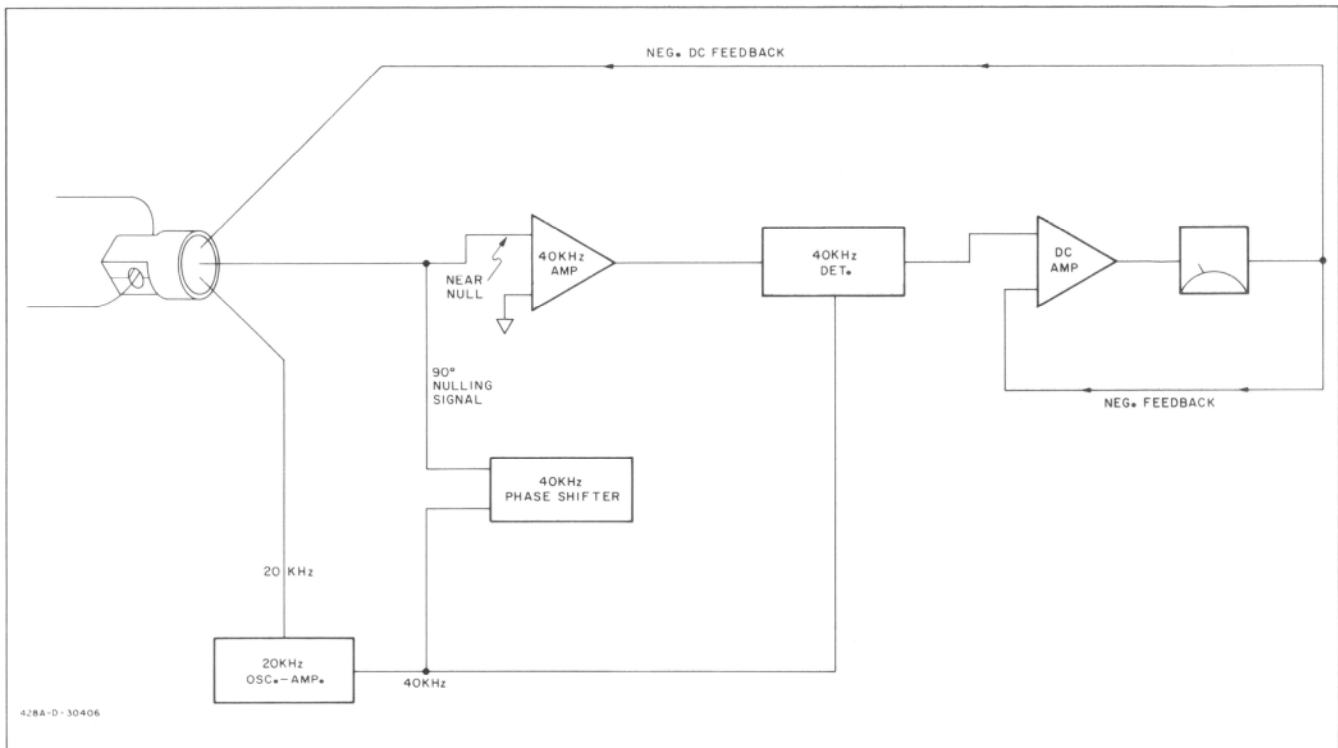

**Figure 4-2. Simplified Block.**



Model 428B

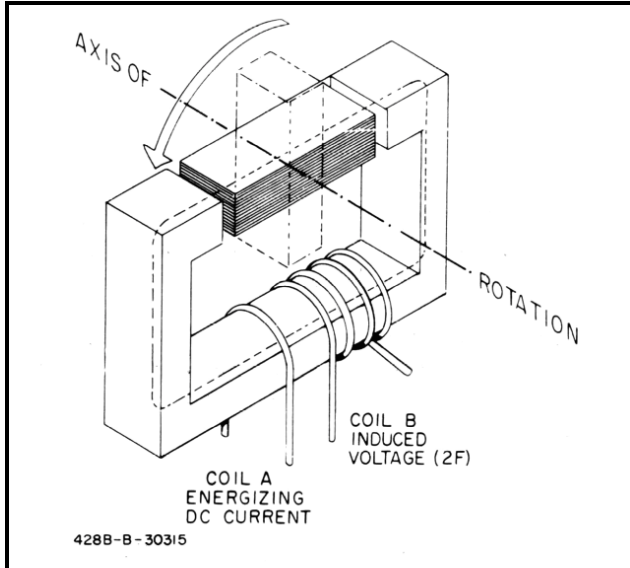

Figure 4-3. Magnetic Mechanical Analogy.

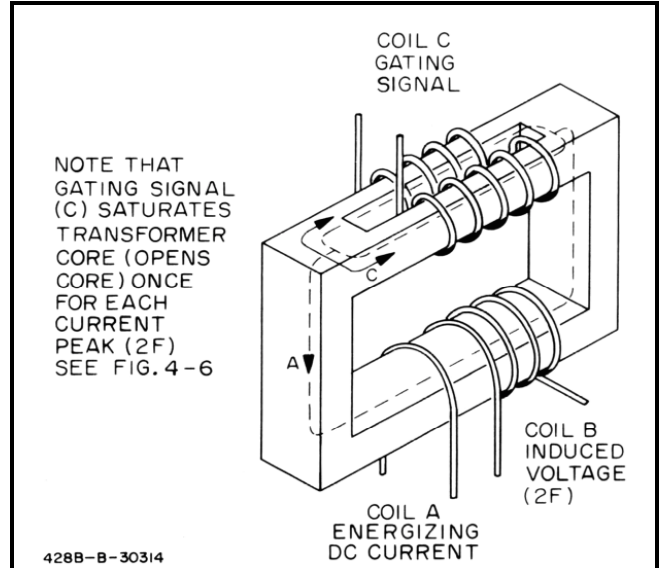

Figure 4-4. Basic Flux Gate.

4-13. The Model 428B head uses this principle in a similar way. Figure 4-4 shows the basic concept of a saturable flux gate.

4-14. A magnetic core in saturation loses permeability and, therefore, is comparable to a core that has been mechanically opened (low permeability due to air gap).

4-15. Coil C saturates the core periodically with a 20 kHz signal, driving the small cores in and out of saturation twice per cycle or once for each peak (positive or negative) of the input current. (See Figure 4-6) The only function of the 20 kHz signal is to gate the dc flux in the core of the current probe.

4-16. The 428B probe head is actually analogous to the flux gate shown in Figure 4-5. The energizing dc current produces flux path "A". Flux path "A" is periodically interrupted by saturation of the (transformer type) core, a result of the two flux paths "C". Note that the current enters L3 and L4 from the same end and that the coils are wound in opposite directions causing opposite magnetic polarities and the consequent circular flux path (c).

4-17. The four coils in the 428B probe head serve 3 purposes: (a) To saturate the cores, a result of the 20 kHz current that flows between pins 1 and 2. This current is generated by the 20 kHz oscillator-amplifier circuits. (b) To act as a secondary, picking up a chopped signal from the

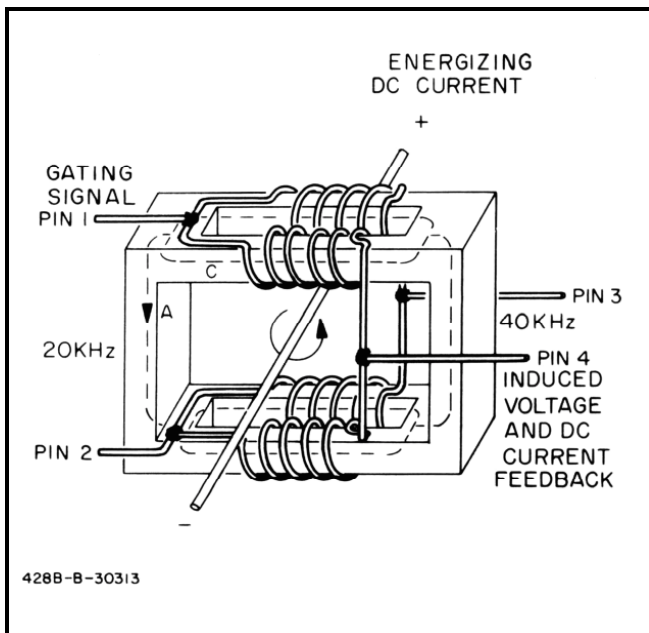

Figure 4-5. 428B Flux Gate.

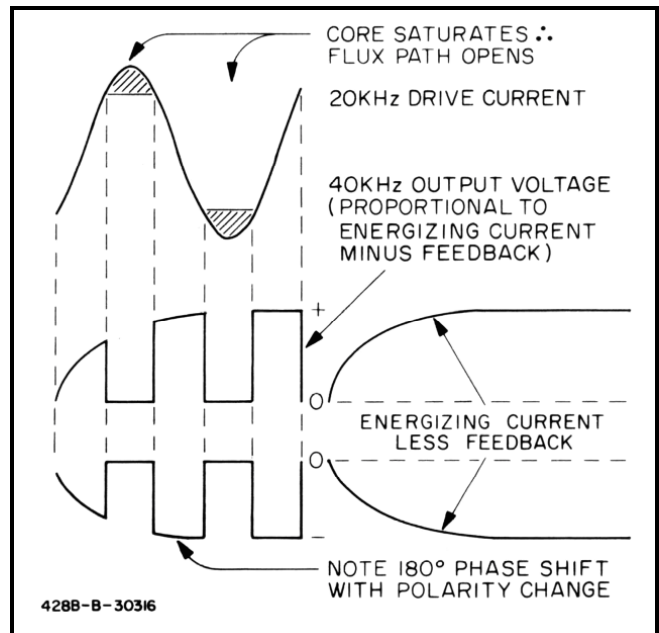

Figure 4-6. Waveforms.

wire that is clamped in the probe jaws. (c) To conduct the dc feedback current that tends to annul the energizing dc current from the wire being measured.

4-18. Because the coils are electrically arranged in a balanced bridge circuit, the 20 kHz signal is balanced at the output of the bridge (pins 3 and 4); and there is no 20 kHz differential signal at this point. The 40 kHz signal and the dc feedback current are also nulled out by the balanced bridge so that these signals do not appear as a differential voltage across pins 1 and 2. The dc feedback current is isolated from the 40 kHz amplifier by capacitor C11. The 40 kHz is kept out of the dc circuitry by RF choke L6.

**4-19. 20 kHz OSCILLATOR.**

4-20. The function of the 20 kHz oscillator is to generate a balanced 20 kHz signal which, after amplification, is used for driving the probe head in and out of saturation.

4-21. The circuit of the 20 kHz oscillator is shown in Figure 7-10. The oscillator V7 is operating in push-pull having a plate circuit tuned to 20 kHz. Transformer coupling provides positive feedback through resistor R94 and R95 to the oscillator control grids. The control grids of oscillator V7 supply the drive signal for the push-pull head drive amplifier V8. The oscillator level is adjusted by controlling the cathode current of V7.

4-22. The common cathodes of oscillator V7 supply the 40 kHz signal (2 pulses per 20 kHz cycle) needed for the synchronous detector gate amplifier V5 and the 40 kHz phase shifter.

**4-23. HEAD-DRIVE AMPLIFIER.**

4-24. The head-drive amplifier V8 supplies the balanced 20 kHz signal for the probe head. Drive balance adjustment R98 controls the current ratio of the two triode sections, and hence the second harmonic output. The dc bias voltage for the oscillator and the head-drive amplifier is obtained from reference tube V11.

**4-25. DETECTOR GATE AMPLIFIER.**

4-26. The 40 kHz resonant circuit C1, C2, and L5 increases the level of the gate signal and filters out all signals except 40 kHz. It also allows phase adjustment of the signal to correspond to the phase of the Synchronous Detector.

4-27. The operation of the Synchronous Detector requires a high level 40 kHz signal. The 40 kHz output signal of the oscillator V7 passes through a tuned circuit and drives the gate amplifier V5. The output of V5 delivers a 40 kHz gate signal to the Synchronous Detector.

**4-28. 40 kHz INPUT/AMPLIFIER CIRCUIT.**

4-29. The 40 kHz output voltage of the probe head is resonated by a 40 kHz series resonant circuit (L5 and C1/C2). Resistor R1 broadens the resonance response by lowering the Q to minimize drift problems. The 40 kHz

signal passes through a voltage divider SI B, which keeps the loop gain constant for all current ranges by maintaining a constant input level range to stage VI. The output of the 40 kHz amplifier VI is band-pass coupled to the 40 detector driver stage V2. The output signal of V2 is isolated from ground by transformer T2, and fed to the 40 synchronous detector.

**4-30. SYNCHRONOUS DETECTOR AND FILTER (C24).**

4-31. The Synchronous Detector detects the amplitude and the phase of the 40 kHz signal. Phase detection is necessary to preserve negative feedback at all times. Since the probe may be clipped over the wire in either of two ways the phase of the signal may vary by 1800. If phase detection were not present this 1800 phase reversal would cause positive feedback and the instrument would oscillate. With phase detection the polarity of the feedback will change also, maintaining the feedback negative around the system at all times.

4-32. The synchronous detector requires a large 40 kHz gating signal, having the frequency of the desired signal. Figure 4-7 shows the synchronous detector drawn as a bridge circuit.

4-33. On one half-cycle, with A much more positive than E and with B equally more negative than E, the balanced circuit ACB conducts hard, and C becomes effectively equal to point E. Circuit BDA is opened at this time by its back-biased diodes, and only the signal that appears across the conducting half of the T2(FC) will charge C24.

4-34. On the next half-cycle BDA conducts, ACB becomes open, and the signal across FD will charge C24. If signal F is positive with respect to C on the first half-cycle, signal F will be positive with respect to D on the second half-cycle, and the top of C24 will consistently be charged positive. If the signal at F changes phase by 1800 with respect to the gating signal at T3, the top of C24 will consistently be charged negative.

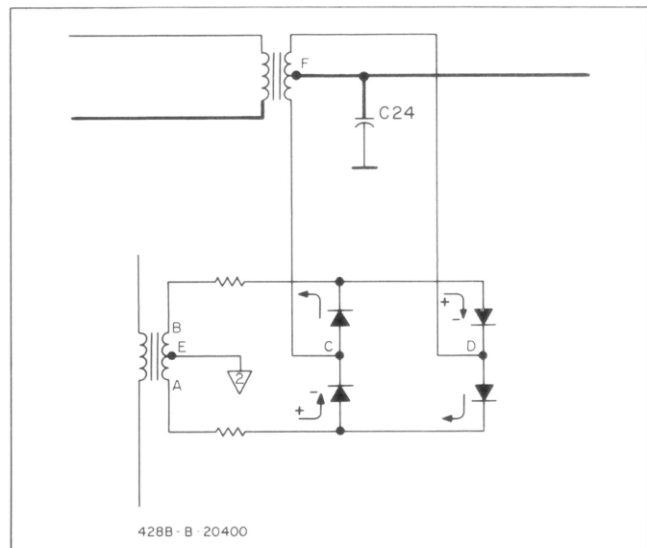

**Figure 4-7. Detector Bridge.**

4-35. In summary then, C and D are alternately grounded, and the polarity of the signal across T2 changes as C and D are switched to produce an output wherein the polarity is dependent on the phase of the input. Where C is in phase with A, F will be negative when C and D are grounded. Where C is 180° out of phase with A, F will be positive when C and D are grounded.

**4-36. DC AMPLIFIER.**

4-37. The dc amplifier supplies a negative dc feedback current to the probe proportional to the output of the synchronous detector. The polarity of the negative feedback current changes if the polarity of the dc current (measured in the probe) changes. In this way the feedback of the system remains negative at all times thus maintaining the stability of the instrument.

4-38. In addition, this local negative feedback loop stabilizes the gain of the DC Amplifier.

4-39. Tube V6 is a differential amplifier in which a signal of approximately 1 volt (for full-scale deflection) is fed to pin 7 and compared with the signal on pin 2. The output of V6 is fed to the base of Q3.

4-40. Transistor Q3 drives the current-amplifiers Q1 and Q2 which are used as emitter-followers in a push-pull NPN-PNP pair combination.

4-41. The output current from the complimentary pair, Q1 and Q2, goes through the meter circuit to the current divider S1A which feeds a portion of this current, appropriate for the range this instrument is working on, to the probe head as negative current feedback.

4-42. After passing through S1A and the probe head, the combined current goes through the parallel resistor network R60-64. This develops a voltage at the junction of R61 and R62 which is proportional to the feedback current. This voltage is applied to pin 2 of V6 to complete the local feedback loop of the DC Amplifier. This circuit makes the output current of the DC Amplifier proportional to the voltage applied to the input grid, pin 7, of V6.

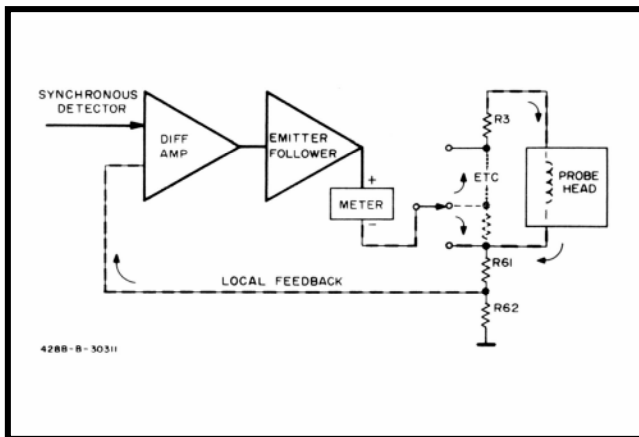

**Figure 4-8. Negative Feedback**

**4-43. NEGATIVE FEEDBACK CURRENT CIRCUIT.**

4-44. The negative feedback current path is shown in Figure 4-8 . Current divider S1 A divides the feedback current in proportion to the dc current being measured\*. For a dc input of 10 A, approximately 50 mA feedback current is fed to the probe head. Since an equal number of ampere-turns are necessary for canceling the main dc flux, the feedback coil inside the head requires approximately 200 turns.

\* Maintaining the current through meter M1 constant (5 mA maximum) for all current ranges. Inductance L6 isolates the 40 kHz signal from the dc current circuit.

**4-45. 40 kHz PHASE SHIFTER.**

The output of the 40 kHz phase shifter is fed to the head of the probe to cancel any residual 40 kHz output signal which exists when zero dc is being measured. The canceling signal is obtained by adding two voltages which are 90° out of phase and variable in amplitude. Figure 4-9 shows the circuit and the idealized phase relationship of the two output voltages with respect to the signal from the oscillator.

By adding the two output voltages (vector A and B) a 40 kHz signal is obtained, having phase angle and amplitude to cancel exactly the residual 40 kHz signal from the probe (vector C). Once the residual 40 kHz signal of the probe has been canceled, the ZERO control compensates for any normal variations of zero shift. This control is necessary only on the lower ranges.

**4-48. POWER SUPPLY.**

4-49. A single series-regulated power supply of the conventional type provides 280 volts regulated for the circuits of the instrument. Voltage reference tube V11 provides a constant cathode potential at control tube V10, and this is the reference potential for the control grid of V10.

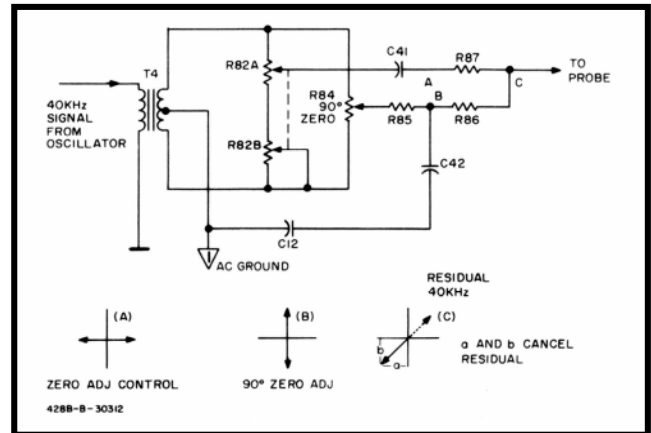

**Figure 4-9. 90° Phase Shift**

**Table 5-1. Recommended Test Equipment.**

EQUIPMENT	REQUIRED CHARACTERISTICS	USE	RECOMMENDED MODEL
Meter Calibrator	$\pm 0.2\%$ of reading $\pm 0.1\%$ FS	Range Check Meter Tracking Output Calibration AC Overload	-hp- Model 69208 AC/DC Meter Calibrator
Function Generator	DC to 400 Hz > 10 mA output	Frequency Response AC Overload	-hp- Model 3310A Function Generator
Oscilloscope	DC to 40 kHz 100 mV/cm $\pm 3\%$	Frequency Response AC Overload Troubleshooting	-hp- Model 130C 200 $\mu$ V/cm Oscilloscope
Resistor	50 Ohms $\pm 1\%$	Frequency Response AC Overload	-hp- Part No. <del>0698-3128</del> 0698-8155
DC Voltmeter	$\pm .25\%$ at 730 mV	Output Calibration	-hp- Model <del>3430A</del> 3469B DC Digital Voltmeter
AC Voltmeter	Resolves 2 mV Battery operated	Noise Check	-hp- Model 4038 AC Portable Voltmeter
Resistor	1 kilohm $\pm 1\%$	Output Calibration Noise Check	-hp- Part No. 11034-82601
Volt-Ohmmeter	Input impedance: $\geq 1$ megohm	Troubleshooting	-hp- Model 427 A Multi-Function Meter
Oscilloscope Probe	Input Impedance: 10 megohms	All Troubleshooting	-hp- Model 10001A Resistive Divider Probes
Counter	Reads 40 kHz $\pm 20$ Hz	Alignment Troubleshooting	-hp- Model 5321 B
Capacitor	.0082 $\mu$ F $\pm 10\%$ 300 Vdc	Alignment	_____
Resistor	390 Ohms $\pm 5\%$ 1/2 W	Alignment	_____

## SECTION V

### MAINTENANCE

#### 5-1. INTRODUCTION.

5- 2. This section contains the service information which is required to properly maintain the 428B Clip-On Milliammeter. Included are performance checks, adjustment and calibration procedures, and servicing and troubleshooting information.

#### 5-3. TEST EQUIPMENT REQUIRED.

5-4. The test equipment required to perform the operations outlined in this section is listed in Table 5-1. This table includes the type of equipment, critical specifications, purpose, and recommended model. If the model recommended is not available, equipment which meets or exceeds the critical specifications listed may be substituted.

#### 5-5. IN-CABINET PERFORMANCE CHECKS.

5-6. The performance checks described in Paragraphs 5-7 through 5-24 are front panel procedures designed to compare the Model 428B with its published specifications. These tests may be incorporated into periodic maintenance, post repair, and incoming quality control checks. The performance checks should be conducted before any attempt is made to adjust or calibrate the instrument. During the in-cabinet performance checks, the Model 428B should be connected to the ac line through a variable voltage device so that line voltage may be varied  $\pm 10\%$  from 115 or 230 Vac to assure that the instrument operates correctly at various ac line voltages.

#### 5-7. CLEANING OF PROBE JAWS.

5-8. When the probe shows excessive sensitivity to the magnetic fields around it, the probe jaws should be cleaned (to determine excessive sensitivity, see Paragraph 5-24 Step a). Excessive sensitivity to external fields can be caused by foreign material between the probe jaws or by overheating (see Paragraph 3-3 Step d). The probe jaws should always be cleaned prior to calibration, adjustment or repair of the 428B.

5-9. To clean the probe jaws, open the probe and brush off the mating surfaces with the brush which is supplied with the instrument. If the brush will not remove the contaminant, disassemble the probe and clean it with a pencil eraser as illustrated. When reassembling the probe, be sure that the arrow on the body of the probe points to the heavy red wire as shown in Figure 6 - 1 .

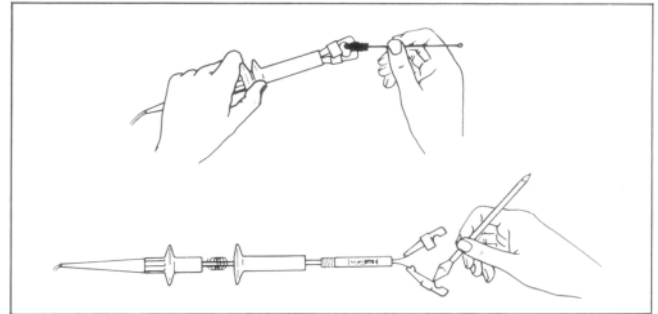
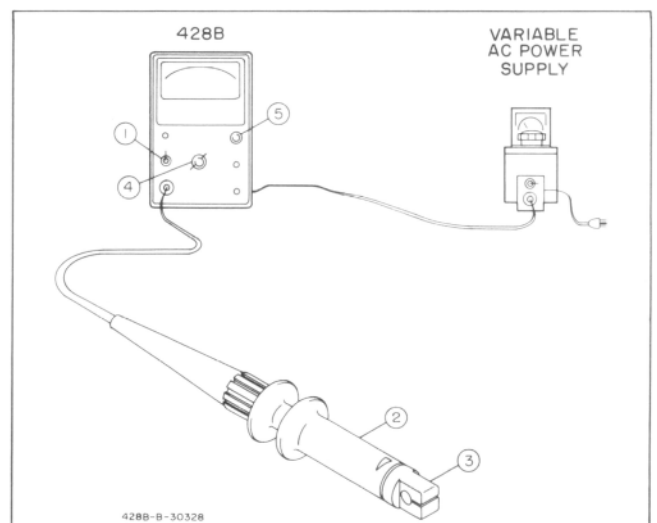

**Figure 5-1. Cleaning Probe Jaws.**

#### 5-10. ELECTRICAL ZERO SET.

5-11. In the following procedure the numbers in parentheses refer to Figure 5-2.

- a. Connect the 428B to the power line through a variable transformer .
- b. Turn on power (1) and allow about two minutes of warmup time.
- c. Place probe (2) away from any stray fields such as meter magnets, or open core transformers.
- d. Insure that the probe jaws (3) are completely closed (Paragraph 5-24 Step a, outlines a way to do so).
- e. Set RANGE switch (4) to 1 mA.
- f. Zero-set the 428B with the ZERO (5) control. If the meter cannot be zeroed, degauss the probe (Paragraph 3-29) or clean the probe jaws (Paragraph 5-8).
- g. Change the line voltage from 103 to 127 volts ( $\pm 10\%$ ) and read zero drift on the 428B meter. Zero drift should not exceed  $\pm .03$  mA.



**Figure 5-2. Electrical Zero Set.**

Model 428B

5-12. Allow a 30 minute warmup and stabilization period before conducting the following performance checks.

### 5-13. RANGE CHECK.

5-14. Figure 5-3 illustrates the test arrangement recommended. A de meter calibrator is required for this test.

- a. Zero the 428B on the 1 mA range.
- b. Switch the 428B and the meter calibrator to the 10 amp range. Set the meter calibrator for 5 amps of output (maximum output for the recommended 6920B). Connect a test lead between the output terminals of the meter calibrator and loop the test lead through the jaws of the 428B twice (see Figure 3-3). The 428B should read 10 amps  $\pm$  0.3 amp.
- c. Switch the meter calibrator to the 1 amp range and adjust it for 1 amp of output. Remove the test lead from the 428B Probe jaws. Zero the 428B, then loop the test lead 3 times through the 428B probe jaws. Switch the 428B to the 3 amp range. The 428B should read 3 amps  $\pm$  90 mA.
- d. Remove the test lead from the 428B probe jaws and zero set the 428B. Clamp the jaws over the unlooped lead after switching the 428B to the 1 amp range. The 428B should read 1 amp  $\pm$  30 mA.
- e. Continue to downrange the 428B and the meter calibrator as in Steps c and d and as guided by the Performance Check Test Card. Where possible, keep the calibrator at full output to take advantage of the greater accuracy; this consideration applies to any meter calibrator which is specified at full range (or full-scale) output. Note that there will be a small residual magnetism induced in the probe by the 10 amps of current that have been passed through the probe, and that it is good practice to degauss the probe before using the 1 mA range.

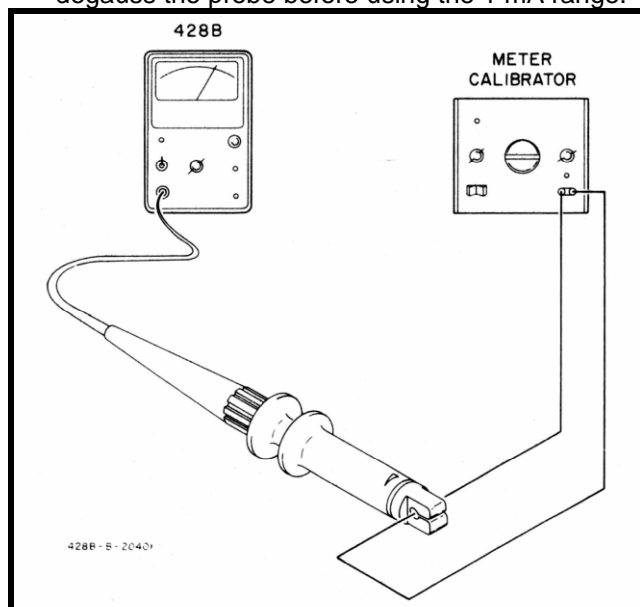

Figure 5-3. Range Check.

### 5-15. METER TRACKING.

5-16. The test arrangement and equipment required for this test are the same as for Paragraph 5-13.

- a. Zero the 428B on the 1 mA range.
- b. Switch the 428B to the 100 mA range. Switch the meter calibrator to the 10 mA range and adjust for 10 mA of output. Connect a long, thin test lead to the output terminals of the meter" calibrator and loop the lead ten times through the jaws of the 428B probe. Read 100 mA  $\pm$  3 mA on the 428B. Remove the test lead from the jaws of the probe one loop at a time and check the linearity of the readings. Each reading should be within 3 mA of nominal (e.g. 90  $\pm$  3 mA, 80  $\pm$  3 mA. etc.).

### 5-17. OUTPUT CALIBRATION.

5-18. A meter calibrator and a one kilohm resistor are required for this test.

- a. Switch the 428B and the meter calibrator to the 100 mA range. Connect a test lead between the meter calibrator output leads and clip the 428B probe to the lead.
- b. Set the meter calibrator to 100 mA output and read full-scale on the 428B.
- c. Connect a voltmeter to the output jack of the 428B. In parallel with the 1000 ohm resistor.
- d. The voltmeter should read 0.73 V  $\pm$  10 mV.

### 5-19. FREQUENCY RESPONSE.

5-20. A 50 ohm resistor and a function generator are required to complete this check.

- a. Connect a 50 ohm resistor to the high output jack of the function generator.
- b. Turn the 428B RANGE switch to 100 mA then clip the 428B probe around the resistor lead.
- c. Set the function generator to:  
Range: .0001    Function: Square  
DC Offset: 0    Frequency Dial: 5
- d. Upon the first up-scale alternation to the 428B, set the function generator Output Level control for a full-scale reading on the 428B.
- e. Connect the vertical input of the oscilloscope to the output jack of the 428B.
- f. Set the coupling of the oscilloscope input to DC. Set sensitivity and vernier to display variations of the 428B output as a 10 centimeter peak -to-peak signal.
- g. Set the function generator to the sine function.
- h. Slowly raise the frequency of the function generator output using the frequency dial and function switch as necessary to bring the output to 400 Hz. Watch the oscilloscope, looking for the lowest amplitude of peak deflection.
- i. The peak-to-peak level of the waveform should not drop below 7 centimeters (-3 dB).

**5-21. AC OVERLOAD.**

5-22. An oscillator or function generator, a 50 ohm resistor, an ac voltmeter or oscilloscope, and the meter calibrator are required to complete this check (a filament transformer and suitable current limiting resistors can be substituted for the oscillator).

- a. Set the meter calibrator for 10 mA. With the 428B on the 10 mA range clip the 428B probe onto the lead which connects the calibrator terminals.
- b. Note the 428B reading.
- c. Set the function generator to 60 Hz, its output to generate a 10 mA peak sine wave into a 50 ohm resistor (1 volt peak-to-peak or 0.35 volt rms across a 50 ohm resistor).
- d. Clip the 428B probe onto BOTH the wire from the meter calibrator and the resistor lead from the function generator (see Figure 5-4).
- e. The 428B should read within 2% of the reading noted in Step b.

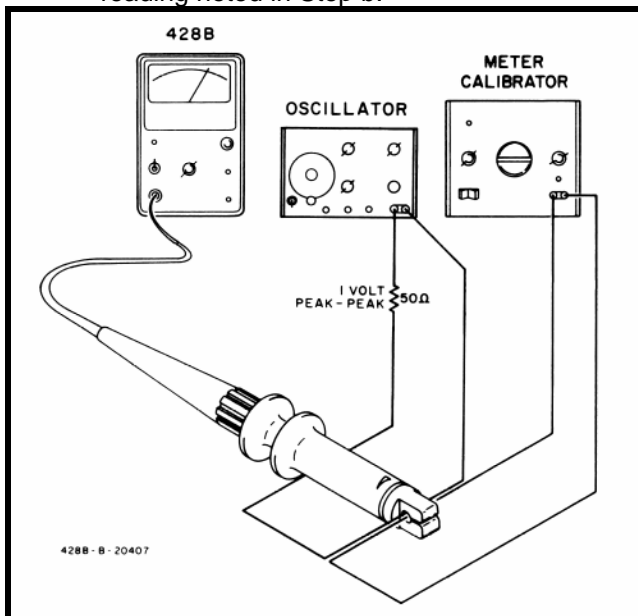

**Figure 5-4. AC Overload.**

**5-23. NOISE CHECK.**

5-24. A battery operated ac voltmeter and a 1 kilohm resistor are required to complete this check.

- a. Point probe East and West and rotate about its axis.
- b. Note peak-to-peak change in meter reading, if it doesn't exceed 0.1 mA on the 1 m A range, proceed. If the change is excessive, perform Paragraph 5-8.
- c. Zero the Model 428B on the 1 mA range.
- d. Connect the output of the 428B to the input of a battery operated 403 B with a 1 kilohm resistor in parallel with the 403B input.
- e. Section V

- f. With the 428B on the 1 mA Range check for a maximum of 15 m V reading on the AC Voltmeter.
- g. Switch the 428B to the 3 mA range. Check for a maximum of 5 m V reading on the AC Voltmeter.
- h. Switch the 428B to the 10 mA range. Check for a maximum of 2 mV reading on the AC Voltmeter.
- i. Check each range from 10 mA to 10 amps using the procedure of Step f. No ac output reading should exceed 2 mV.

**5-25. ADJUSTMENT PROCEDURE.**

5-26. When the instrument shows signs of defective components, use the troubleshooting procedure to find and correct the problem. It is quite easy to compound a 428B trouble by misaligning the instrument in an attempt to adjust out the effects of a defective component.

**5-27. POWER SUPPLY.**

5-28. Connect an electronic dc voltmeter to test point 5 (Pin 1, V9) of the 428B. The voltage at this point should be  $272 \pm 6$  V if not, adjust R109 for 272 V.

**5-29. MECHANICAL ZERO SET.**

5-30. When meter is properly zero set, pointer rests over the zero calibration mark on the meter scale when instrument is (1) at normal operating temperature, (2) in its normal operating position, and (3) turned off. Zero set as follows to obtain best accuracy and mechanical stability:

- a. Allow instrument to operate for at least 20 minutes; this allows meter movement to reach normal operating temperature.
- b. Turn instrument off and allow 30 seconds for all capacitors to discharge.
- c. Rotate mechanical zero adjustment screw clockwise until meter pointer is to left of zero and moving upscale toward zero..
- d. Continue to rotate adjustment screw clockwise; stop when pointer is right on zero. If pointer overshoots zero, repeat Steps c and d.
- e. When pointer is exactly on zero, rotate adjustment screw slightly counterclockwise to free adjustment screw from the meter suspension. If pointer moves during this step, repeat Steps c through e.

**5-31. DC AMPLIFIER BALANCE.**

5-32. Open the 428B and short across the brass pins on the circuit board which are connected to the ends of C1 0 (these pins are located on either side of C14). Connect a 1500 ohm resistor between Pin 2 of V6 and the 6.3 V filament supply. Disconnect the feedback disconnect (see Figure 7-3). Zero the 428B meter with R46.

Model 428B

5-33. Remove the clip lead and resistor. Replace the feedback disconnect jumper.

#### 5-34. ALIGNMENT.

#### 5-35. OSCILLATOR BALANCE.

5-36. Construct a probe as shown below:

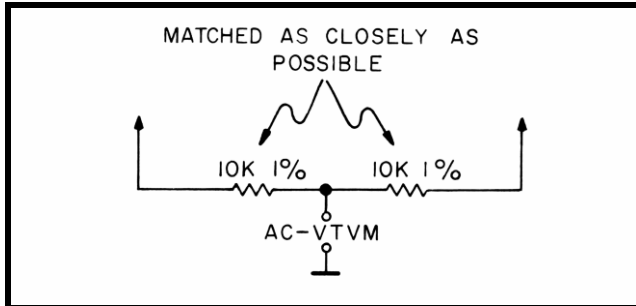

**Figure 5-5. Oscillator Balance Probe.**

Connect the ends of the probe to the T5 side of R94 and R95. Connect an ac voltmeter between ground and the junction of the two probe resistors. To adjust oscillator balance, pad C53 or C54 for minimum reading (on instruments with serial prefixes of 601- or below, adjust the slug of T5). The ac reading at the junction of the probe resistors should be 50 mV or less. Remove the probe and meter before proceeding.

#### 5-37. OSCILLATOR FREQUENCY.

5-38. Connect an ac coupled electronic counter to test point 4. Adjust the slug of T5 to set the frequency measured to 40 kHz  $\pm$  200 Hz. If T5 doesn't have enough range, pad C52 (in instruments with serial prefixes of 601- or below do not use T5; use C52 only). Remove counter.

#### 5-39. OSCILLATOR LEVEL.

5-40. Connect an ac voltmeter to Test Point 6 (Pin 7, V7). Adjust R92 for 8  $\pm$  0.4 V. Remove meter.

#### 5-41. DETECTOR GATE.

5-42. Connect an ac voltmeter to Test Point 4 (Pin 7 of V5). Adjust L7 for a peak reading.

#### 5-43. TUNED AMPLIFIER.

#### 5-44. Equipment Setup.

5-45. Set an ac voltmeter to the 1 volt range and connect it to Test Point 3 (Pin 7, V2) of the 428B. Clip the 428B probe around a wire which is carrying 35 mA rms ac. This current can be generated by a filament transformer, as in Figure 5-6, or by an oscillator operating into its rated load as in Paragraph 5-20. Set the 428B RANGE switch to 100 mA. This arrangement will be used for input, interstage, and detector phase adjustments.

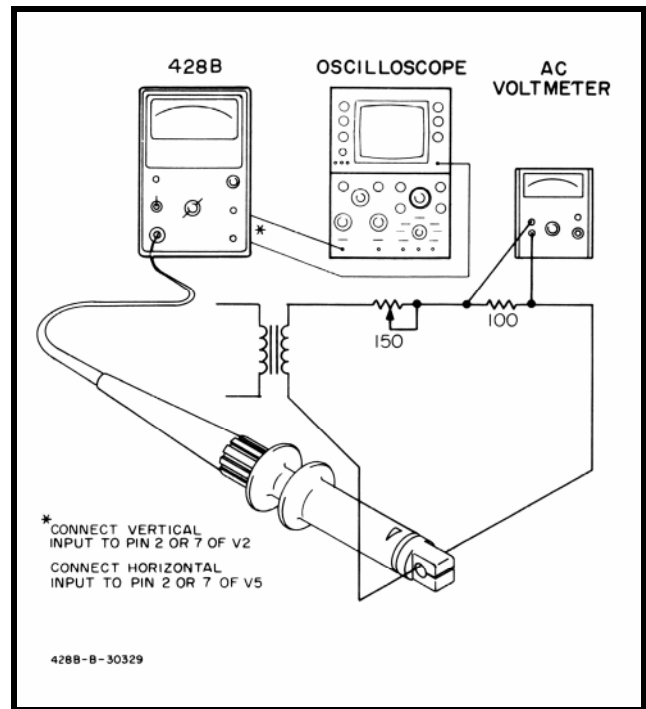

**Figure 5-6. Detector Phase Adjustment.**

#### 5-46. Input Alignment.

5-47. Short TP1 and TP2 to ground, open the feedback disconnect shown in Figure 7-3, then adjust C2 for a maximum ac reading at Test Point 3 (Pin 7 of V2).

#### 5-48. Interstage Alignment.

5-49. Set up equipment as in Paragraph 5-45, then:

a. Connect a .0082 microfarad capacitor across the brass pins which are connected to L10. Adjust L9 for maximum ac at Test Point 3 (Pin 7 of V2).

b. Remove the capacitor. Connect the .0082 microfarad capacitor across the brass pins which are connected to L9. Adjust L10 for maximum ac at TP3.

c. Remove the capacitor and voltmeter.

#### 5-50. DETECTOR PHASE ADJUSTMENT.

5-51. With the bases of Q1 and Q2 (TP1 and TP2) grounded, open the feedback disconnect jumper (see Figure 7-3), and install a 390 ohm resistor between the feedback wire and the pin on the circuit board to which it normally connects. Connect the horizontal input of an oscilloscope to TP4 (Pin 7, V5). Connect the vertical to TP3 (Pin 7, V2). Except for the ac voltmeter, set up equipment as in Paragraph 5-45 (a proper setup is shown in Figure 5-6). Turn slug of L7 until the pattern looks like one of the correct patterns shown in Figure 5-7. If there is a diamond in the center of the pattern, the diamond should contain no traces. Remove the 390 ohm resistor and the voltmeter.



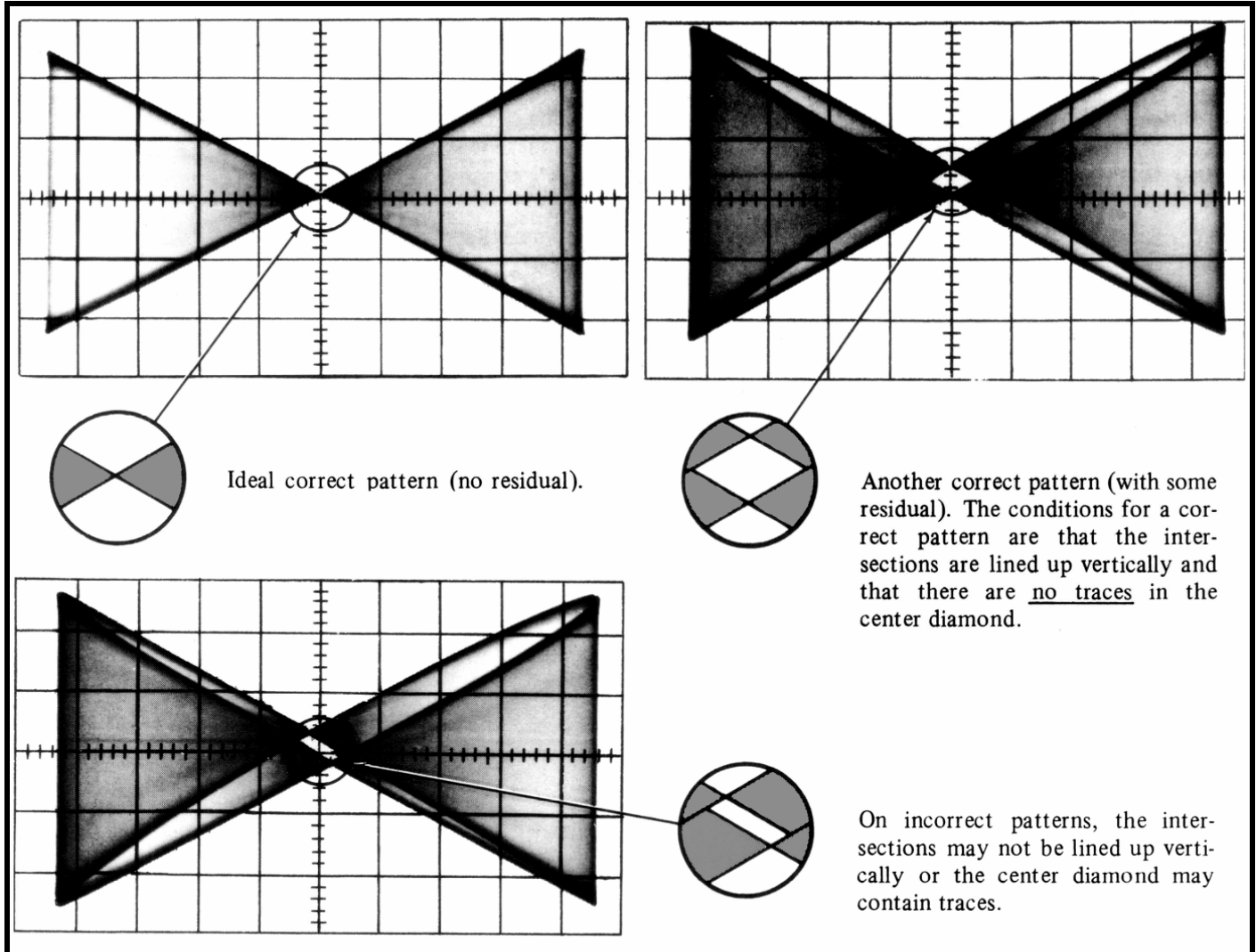

Figure 5-7. Detector Phase Display.

**5-53. Preliminary Adjustment.**

**5-54. Preset the controls as follows:**

- a. Ground the bases of Q1 and Q2 (TP1 and TP2). Open the feedback disconnect (see Figure 7-3).
- a. Switch the 428B to the 300 mA range.
- b. Adjust R84 for minimum ac at the wiper connection of R84. The reading should be less than 0.1 volt.
- c. Adjust R82 for minimum ac at the wiper connection of R8-2. The reading should be approximately 0.02 volt.
- d. Thoroughly clean probe head jaws (see Paragraph 5-8).
- e. Degauss probe head (see Paragraph 3-29).

**5-55. Drive Balance Adjustment.**

5-56. With the 428B set to the 1 mA range, and with no input to the current probe, set R98 for a minimum ac reading at Test Point 3 (Pin 7 of V2). The minimum reading should be less than 0.5 volt.

5-57. Residual 40 kHz Cancellation.

5-58. The residual output of the probe head is cancelled by means of the circuit discussed under Paragraph 4-45. This procedure assumes that the preliminary adjustments listed in Paragraph 5-54 have been completed.

- a. Reconnect the feedback disconnect which was opened in Paragraph 5-54 Step a.
- b. Remove the short between the bases of Q1 and Q2 and ground (installed in Paragraph 5-54 Step a).
- c. Degauss the probe.
- d. Zero the 428B meter with front panel ZERO control.
- e. Adjust R84 for a minimum ac reading at Test Point 3 (Pin 7 of V2).
- f. Continue to alternate Steps d and e until the adjustment cannot be further refined. The minimum reading in Step e should be approximately 0.02 volts or less.

**5-59. TROUBLESHOOTING.**

**5-60. FRONT PANEL TROUBLESHOOTING.**

5-61. The Front Panel Troubleshooting Tree was designed for use as a means to guide the repairman to a block of circuitry. This procedure, in combination with the adjustment, calibration, and performance checks should be adequate to repair most 428B's.

5-62. In any case where the front panel troubleshooting does not lead to the problem, it will be necessary to troubleshoot the instrument in detail.

**5-63. DETAILED TROUBLESHOOTING.**

**5-64. Probe Check.**

5-65. Resistance between pins 1-3, 1-4, 2-3, and 2-4 of the probe cable connector should be nearly identical and in the area of approximately 4 1/2 to 5 ohms. Where a resistance measurement between any of the above

pairs of pins is significantly higher than between the other pairs (by about 3 times), an open probe coil is indicated. Any open circuit indicates a broken conductor between the plug and the bridge. The broken conductor is probably a broken wire in the cable. Either condition could indicate a broken wire at the Probe Terminal Section (see wiring diagram, Figure 6-1).

**5-66. Power Supply Check.**

5-67. To test the power supply:

- a. Measure +272 ±6 Vdc between Test Point 5 and ground.
- b. Measure +12 ±1 Vdc between the cathode of CR10 and ground.
- c. Measure -7 ±1 Vdc between the anode of CR9 and ground.

5-68. Where the +272 V and the +12 V have both failed, check the +12 first. Check CR10, Q1, C66, and C69.

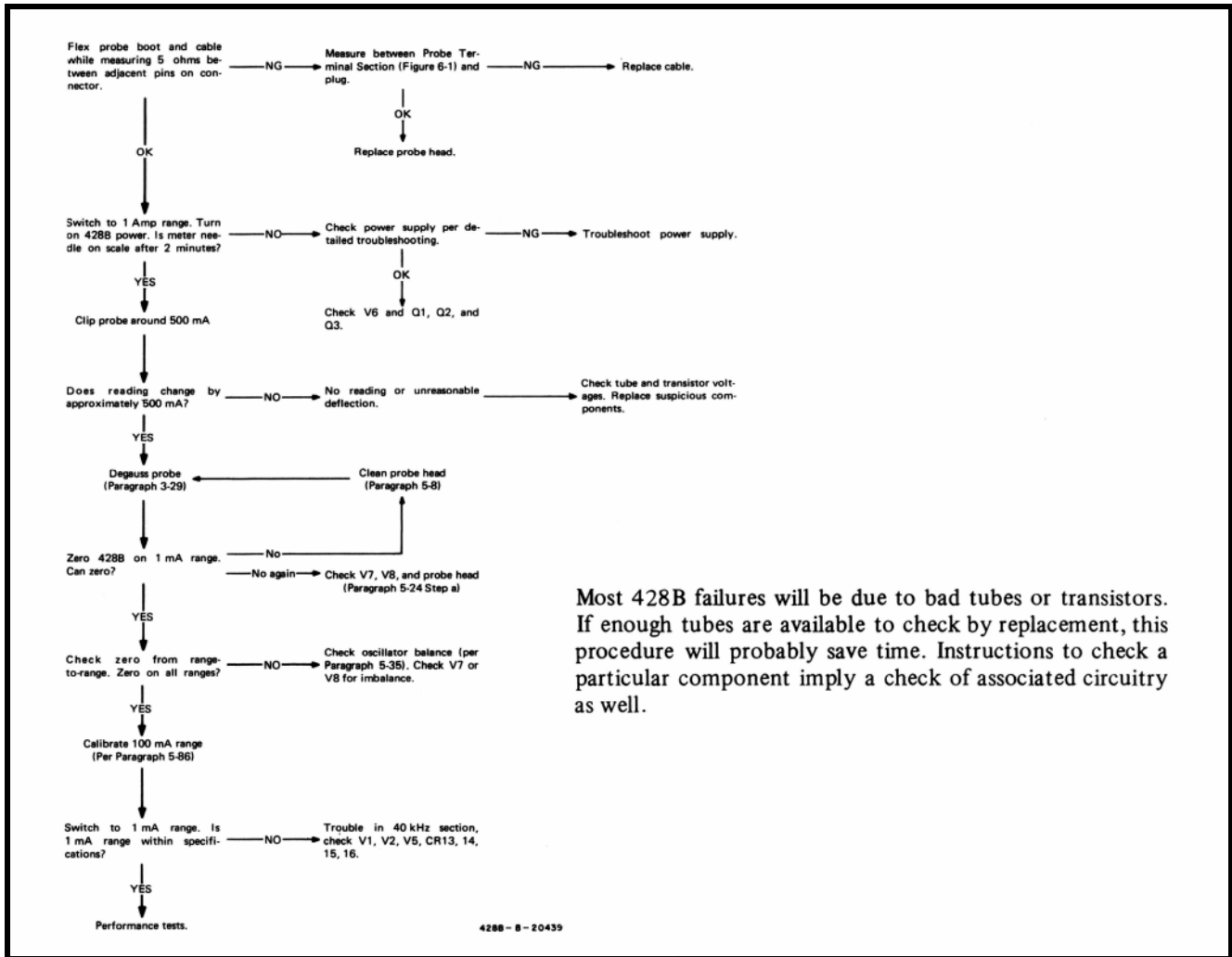

Most 428B failures will be due to bad tubes or transistors. If enough tubes are available to check by replacement, this procedure will probably save time. Instructions to check a particular component imply a check of associated circuitry as well.

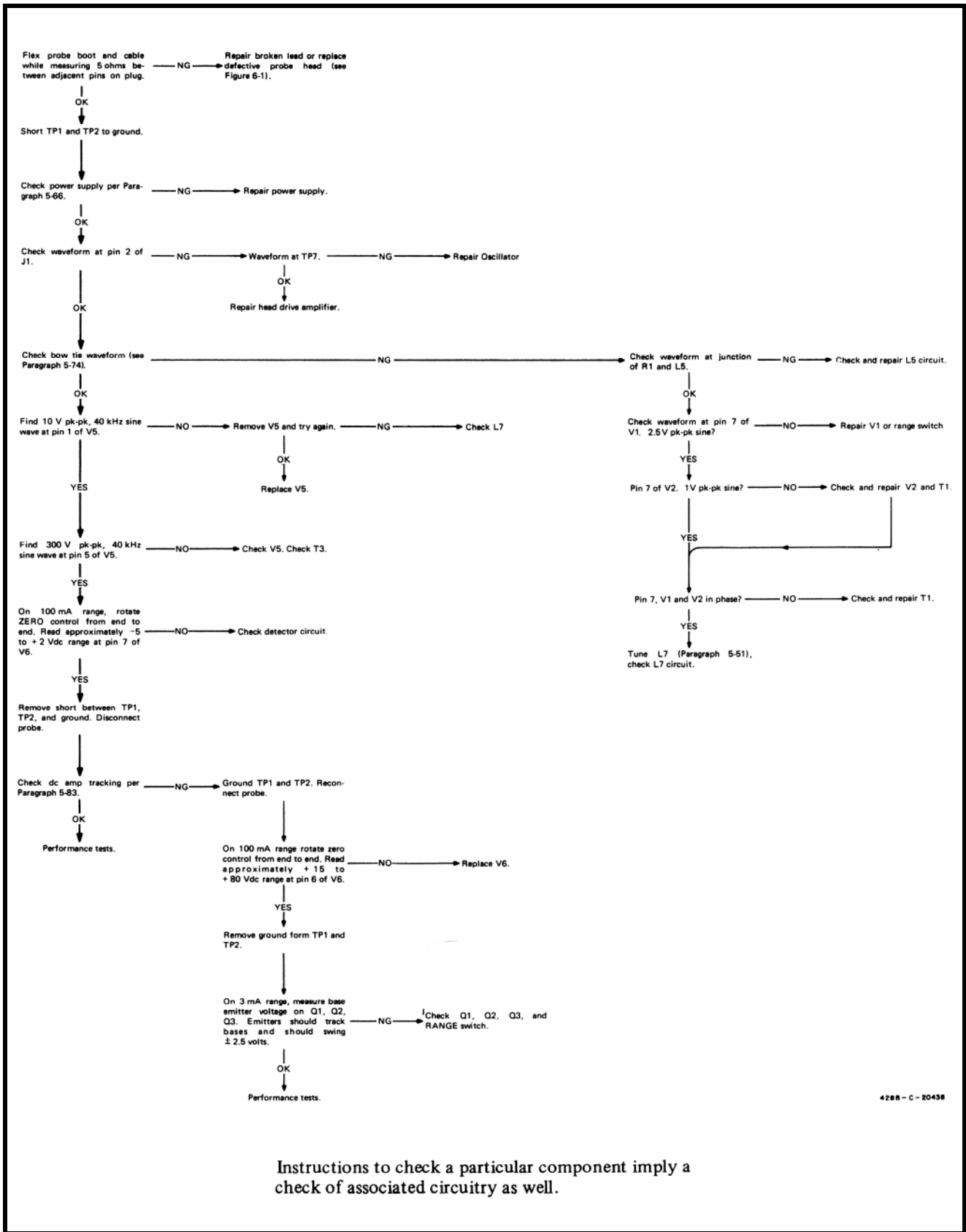

Instructions to check a particular component imply a check of associated circuitry as well.

Figure 5-9. Detailed Troubleshooting Tree.

## Model 428B

5-69. Where the + 272 V is at fault, try replacing V9, V10, or V11. If the tubes are not defective, check the associated circuitry, especially CR11 (V11 in some instruments).

5-70. Where the -7 V has failed, measure -17 Vdc at junction of R102 and C65. If less than -7 volts is measured at this point, check F3 and C65. If the junction of R102 and C65 measures more than - 7 Vdc, check CR9 and Q2.

### 5-71. Oscillator - Buffer Amp. Check.

5-72. Short Test Point 1 and Test Point 2 to ground.

5-73. Compare the waveform at pin 2 of J1 to the waveform shown at this point of the schematic diagram. If these waveforms are not comparable, check the waveform at Test Point 7 and follow the Troubleshooting Tree. If the waveform at pin 2 of J1 is acceptable, continue to the next paragraph.

5-74. Set up equipment as described in Paragraph 5-51. Compare the oscilloscope display to Figure 5-7.

5-75. If the display is unacceptable, clip the probe around 100 mAdc and downrange to the 1 mA range. Find a 2.5 V pk-pk sine wave at the junction of R1 and L5. If this waveform is unacceptable, adjust or repair the input tuning circuit (L5, C1, C2, and R1).

5-76. If the waveform described in Paragraph 5-75 is alright, use the same test setup to find a 2.5 V pk-pk sine wave at pin 7 of VI. If this waveform is unacceptable, check VI and the range switch.

5-77. If the waveform described in Paragraph 5-76 is alright, use the same test setup to look for a 1 V pk-pk sine wave at pin 7 of V2. Follow this branch of the Troubleshooting Tree to its conclusion.

5-78. Detector Gate Amp. Check.

5-79. No test equipment need be set up for these checks except an oscilloscope and a wire to ground TP1 and TP2.

### 5-80. Synchronous Detector.

5-81. With TP1 and TP2 still grounded and on the 100 mA range, perform the test indicated. Beyond a tedious ohmmeter test of the circuitry between T3 and pin 7 of V6, little can be done to check the detector circuit. It should be noted, however, that R46 should be able to provide the + 0.5 Vdc which is required at pin 7 of V6 during normal operation.

5-82. DC Amplifier Check.

5-83. Remove the ground wire from Test Point 1 and Test Point 2 (installed for previous checks). Disconnect the probe from the 428B front panel. Set the 428B to the 300 mA range. Zero the 428B with the front panel ZERO control. Measure and note the voltages at pin 7 and pin 2 of V6. Turn the ZERO control to deliver a  $\pm 1$  Vdc swing around the voltage noted for pin 2. The difference between the voltages at pins 7 and 2 of V6 should not exceed 0.05 Vdc at any point during this swing.

5-84. If the DC Amplifier tracks properly as tested in Paragraph 5-83, proceed with the performance checks. If the DC Amplifier has failed, continue to perform the tests in the Troubleshooting Tree.

5-85. CALIBRATION.

5-86. Zero the 428B on, the 1 mA range using the front panel ZERO control. Switch to the 100 mA range. Clip the probe around an accurate 100 mA current (as in Paragraph 5-14). Adjust Meter Cal, R69, for a meter reading of 100 mA. Connect a 1000 ohm  $\pm 1$  % resistor in parallel with an accurate (0.25%) voltmeter to the output jack of the 428B. Turn the front panel Output Level control full counterclockwise past the detent. Adjust the Output Cal control, R63, for a reading of exactly 0.73 V on the voltmeter.

5-87. Perform the entire In-Cabinet Performance Tests (Paragraphs 5-5 through 5-24) to insure that the 428B meets all of its specifications.

**PERFORMANCE CHECK TEST CARD**  
**MODEL 428B CLIP-ON MILLIAMMETER**

Model 428B  
 Serial No. \_\_\_\_\_

Test performed by \_\_\_\_\_  
 Date \_\_\_\_\_

**RANGE CHECK: PARAGRAPH 5-13**

428B Reading	Meter Calibrator Output	Loops	Limits	Reading
10 A	5 A	2	0.3 A	_____
3 A	1 A	3	.09 A	_____
1 A	1 A	1	.03 A	_____
300 mA	100 mA	3	9 mA	_____
100 mA	100 mA	1	3 mA	_____
30 mA	10 mA	3	0.9 mA	_____
10 mA	10 mA	1	0.3 mA	_____
3 mA	1 mA	3	90 $\mu$ A	_____
1 mA	1 mA	1	30 $\mu$ A	_____

**METER TRACKING CHECK: PARAGRAPH 5-15**

428B Reading	Meter Calibrator Output	Loops	Limits	Reading
100 mA	10 mA	10	3 mA	_____
90 mA	10 mA	9	3 mA	_____
80 mA	10 mA	8	3 mA	_____
70 mA	10 mA	7	3 mA	_____
60 mA	10 mA	6	3 mA	_____
50 mA	10 mA	5	3 mA	_____
40 mA	10 mA	4	3 mA	_____
30 mA	10 mA	3	3 mA	_____
20 mA	10 mA	2	3 mA	_____
10 mA	10 mA	1	3 mA	_____

**OUTPUT CALIBRATION CHECK: PARAGRAPH 5-17**

428B Reading	Meter Calibrator Output	DC Voltmeter	Limits	Reading
100 mA	100 mA	0.73 V	$\pm 10$ mV	_____

**FREQUENCY RESPONSE CHECK: PARAGRAPH 5-19**

428B Reading	Frequency Range	Limits	Reading
10 mA	DC – 400 Hz	>7 cm	_____

**AC OVERLOAD: PARAGRAPH 5-21**

428B Reading	Meter Calibrator Output	Function Generator Output	Limits	Reading
> 9.8 mA	10 mA	10 mA P	< 2%	_____

**NOISE CHECK: PARAGRAPH 5-23**

428B Range	Limits	Reading
1 mA	<15 mV	_____
3 mA	< 5 mV	_____
10 mA – 10 A	< 2 mV	_____

## SECTION VI

### REPLACEABLE PARTS

#### 6-1. INTRODUCTION.

6-2. This section contains information for ordering replacement parts. Table 6-1 lists parts in alphabetic order of their reference designators and indicates the description, -hp- part number of each part, together with any applicable notes, and provides the following:

- a. The TQ column lists the total quantity of any part listed in the manual. The total quantity of a part is given the first time the part number appears.
- b. Description of the part. (See list of abbreviations below.)
- c. Typical manufacturer of the part in a five-digit code. (See Appendix B for list of manufacturers.)
- d. Manufacturer's part number

6-3. Miscellaneous parts are listed at the end of Table 6-1.

#### 6-4. ORDERING INFORMATION.

6-5. To obtain replacement parts, address order or inquiry to your local Hewlett-Packard Field Office. (See Appendix C for list of office locations.) Identify parts by their Hewlett-Packard part numbers. Include instrument model and serial numbers.

#### 6-6. NON-LISTED PARTS.

6-7. To obtain a part that is not listed, include:

- a. Instrument model number.
- b. Instrument serial number.
- c. Description of the part.
- d. Function and location of the part.

#### ABBREVIATIONS

Ag Al A Au C cer coef com comp conn dep DPDT DPST elect encap F FET fxd GaAs GHz gd Ge grd H Hg Hz	silver ID aluminum impg ampere(s) incd gold Ins capacitor kΩ ceramic kHz coefficient L common lin composition log connection mA deposited MHz double-pole double-throw MQ double-pole single-throw metfilm electrolytic mfr encapsulated ms farad(s) mtg field effect transistor mV fixed μF gallium arsenide us Gigahertz=10 <sup>+9</sup> hertz μV guard(ed) my germanium nA ground(ed) NC henry(ies) Ne mercury NO hertz (cyc1e(s) per second) NPO	inside diameter ns impregnated nsr .incandescent Ω .insulation(ed) obd kilohm(s) 10 <sup>+3</sup> ohms OD kilohertz= 10 <sup>+3</sup> hertz P inductor pA linear taper pc logarithmic taper pF milliampere(s) = 10 <sup>-3</sup> amperes megahertz = 10 <sup>+6</sup> hertz piv megohm(s) = 10 <sup>+6</sup> ohms p/o metalfilm pos manufacturer poly millisecond pot mounting p-p millivolt(s) = 10 <sup>-3</sup> volts ppm microfarad(s) prec microsecond(s) microvolt(s) = 10 <sup>-6</sup> volts Mylar® R nanoampere(s) = 10 <sup>-9</sup> amps Rh normally closed rms neon rot normally open Se negative positive zero sect (zero temperature coefficient) Si sl	nanosecond(s) = 10 <sup>-9</sup> seconds SPDT not separately replaceable SPST ohm(s) Ta order by description Te outside diameter TI02 peak tog picoampere(s) tol printed circuit trim picofarad(s) 10 <sup>-12</sup> TSTR farads V peak inverse voltage vacw part of position(s) var polystyrene vdcw potiometer W peak-to-peak wi parts per million wiv precision (temperature coefficient, w/o long term stability, and/or tolerance) * resistor rhodium root-Clean-square ** rotary selenium section(s) Silicon slide	single-pole double-throw single-pole single-throw tantalum temperature coefficient titanium dioxide toggle tolerance trimmer transistor volt(s) alternating current working voltage variable DC working voltage watt(s) with working inverse voltage without wirewound optimum value selected at factory, avg value shown (part may be omitted) no standard type number assigned (selected or special type)
---	--	--	---	---

#### DECIMAL MULTIPLIERS

Prefix	Symbols	Multiplier	Prefix	Symbols	Multiplier
tera	T	10 <sup>+12</sup>	centi	c	10 <sup>-2</sup>
giga	G	10 <sup>+9</sup>	milli	m	10 <sup>-3</sup>
mega	M or Meg	10 <sup>+6</sup>	micro	μ	10 <sup>-6</sup>
kilo	K or k	10 <sup>+3</sup>	nano	n	10 <sup>-9</sup>
hecto	h	10 <sup>+2</sup>	Pico	p	10 <sup>-12</sup>
deca	da	10	femto	f	10 <sup>-15</sup>
deci	d	10 <sup>-1</sup>	atto	a	10 <sup>-18</sup>

#### DESIGNATORS

A B BT C CR DL DS E F	assembly FL motor HR battery IC capacitor J diode K delay line L lamp M misc. electronic part MP fuse P	filter Q heater OCR integrated circuit R jack RT relay S inductor T meter TB mechanical part TC plug TP	transistor TS transistor-diode V resistor W thermistors X switch X transformer XDS terminal board XF thermocouple Y test point Z	terminal strip vacuum tube, neon bulb, photo cell, etc. cable socket lamp holder fuse holder crystal network
---	---	---	--	--

Table 6-1. Replaceable Parts

REFERENCE DESIGNATOR	-hp- PART NO.	TQ	DESCRIPTION	MFR.	MFR. PART NO.
A1, A2	428B-26A	2	Assembly: resistor ww A1 includes R3 thru R6 A2 includes R7 thru R 10	hp-	
A3	428B-268	1	Assembly: resistor ww, includes R2, R11	hp-	
C1	0160-0938	1	C: fxd 1000 pF 5%	14655	RDM15E102J1C obd
C2	0131-0004	1	C: var mica 16-150 pF 175 vdcw	72136	T51410-9
C3 thru C10			Not assigned		
C11	0150-0014	1	C: fxd cer .005 microfarad 500 vdcw	04222	D1-4 obd
C12	0180-0050	1	C: fxd 40 microfarads +75% -10% 50 vdcw	56289	30D406G050DD2-DS
C13	0160-0269	5	C: fxd cer .1 microfarad 20% 500 vdcw	56289	41C9285-CDH
C14	0140-0179	3	C: fxd mica 1000 pF 2%	14655	RDM19F102G3C obd
C15	0150-0012	6	C: fxd cer .01 microfarad 20% 1000 vdcw	56289	29C214A3-CDH
C16, C17	0160-0269		C: fxd cer .1 microfarad 20% 500 vdcw	56289	41C9285-CDH
C18	0140-0179		C: fxd mica 1000 p F 2%	14655	RDM19F102G3C obd
C19	0150-0012		C: fxd cer .01 microfarad 20% 1000 vdcw	56289	29C214A3-CDH
C20			Not assigned		
C21	0180-0059	1	C: fxd 10 microfarads + 75% -10% 25 vdcw	56289	30D106G025882-DSM
C22, C23			Not assigned		
C24	0170-0078	1	C: fxd my .47 microfarad 5% 150 vdcw	84411	663UW
C25	0180-0058	2	C: fxd 50 microfarads +75% -10% 25 vdcw	56289	30D506G025CC2-DSM
C26	0150-0012		C: fxd cer .01 microfarad 20% 1000 vdcw	56289	29C214A3-CDH
C27	0140-0179		C: fxd mica 1000 pF 2%	14655	RDM19F102G3C obd
C28, C29	0150-0012		C: fxd cer .01 microfarad 20% 1000 vdcw	56289	29C214A3-CDH
C30			Not assigned		
C31	0170-0019	1	C: fxd my 0.1 microfarad 5% 200 vdcw	56289	192P10452-PTS
C32 thru C40			Not assigned		
C41	0140-0223	1	C: fxd mica 260 pF 1 %	14655	RDM15F261F3C obd
C42	0160-2204	1	C: fxd mica 100 pF 5%	72136	RDM15F101J3C obd
C43 thru C50			Not assigned		
C51	0160-0269		C: fxd cer .1 microfarad 20% 500 vdcw	56289	41C92B5-CDH
C52	0160-0363	1	C: fxd mica 620 pF 5%	72136	RDM15F621 J3C obd
C53, C54	0140-0164	2	C: fxd mica 6800 pF 5%	14655	RDM30F682J5S obd
C55	0140-0210	1	C: fxd mica 270 pF 5%	00853	RDM15F271 J3C obd
C56 thru C60			Not assigned		
C61	0180-2336	1	C: fxd my 20 microfarads +50% -10% 450 vdcw	56289	68010168
C62	0180-2337	1	C: fxd my 20-20 microfarads +50% 10% 450 vdcw	56289	68D20060
C63	0160-0134	2	C: fxd mica 220 pF 5%	14655	RDM15F221J3C obd
C64	0150 .. 0012		C: fxd cer .01 microfarad 20% 1000 vdcw	56289	29C214A3-CDH
C65	0180-0058		C: fxd 50 microfarads + 75 -10% 25 vdcw	56289	30D506G025CC2-DSM
C66	0180-0104	2	C: fxd 200 microfarads +75% -10% 15 vdcw	56289	30D207G015DF2-DSM
C67			Not assigned		
C68	0160-0269		C: fxd cer .1 microfarad 20% 500 vdcw	56289	41C92B5-CDH
C69	0180-0104		C: fxd 200 microfarads +75% -10% 15 vdcw	56289	30D207G015DF2-DSM
C70	0160-2203	1	C: fxd mica 91 pF 5%	14655	RDM15F910J3C obd
C71	0160-0134		C: fxd mica 220 pF 5%	14655	RDM15F221 J3C obd
CR1	1901-0036	4	Diode: si 1000 piv	04713	SR1358-12
CR2			Not assigned		
CR3	1901-0036		Diode: si 1000 piv	04713	SR1358-12
CR4			Not assigned		
CR5	1901-0036		Diode: si 1000 piv	04713	SR1358-12
CR6			Not assigned		
CR7	1901-0036		Diode: si 1000 piv	04713	SR1358-12
CR8			Not assigned		
CR9	1902-0013	1	Diode: breakdown 6.81 V 10%	04713	SZ1521-7
CR10	1902-0211	1	Diode: breakdown 12.1 V 10%	04713	SZ1521-79
CR11, CR12	1901-0040	2	Diode: si 30 wiv 50 mA 2 pF 2ns	01295	PG512
CR13 thru CR16	1910-0016	4	Diode: germanium 60 wiv 1 microsecond Trr	08257	obd
CR17	1902-3404	1	Diode: breakdown 82.5 V 5%	04713	SZ10939-446
DS1	1450-0049	1	Light Indicator: clear	72765	599-125( clear)

Table 6-1. Replaceable Parts (Cont'd)

REFERENCE DESIGNATOR	-hp- PART NO.	TQ	DESCRIPTION	MFR.	MFR. PART NO.
F1	2110-0202	1	Fuse: .5 AT 250 V (for 230 V operation)	71400	MDL-1/12
F1	2110-0312	2	Fuse: 1 AT 250 V (for 115 V operation)	71400	MDL-1
F2	2110-0312		Fuse: 1 AT	-hp-	
F3	2110-0012	1	Fuse: .5 A 250 V	71400	AGC1/2
J1	1251-0089	1	Connector: female 4 pin	02660	91-PC4F
J2	1251-2357	1	Connector: male 3 pin power	-hp-	
J3	1250-0118	1	Connector: bulkhead, BNC female	24931	28J R128-1
L5	9100-1487	1	Choke	-hp-	
L6	9100-1488	1	Choke	-hp-	
L7	9100-1489	1	Coil: gate input filter	-hp-	
L8	9110-0025	1	Reactor: degausser	-hp-	
L9, L10	9100-1482	2	Coil: interstage	-hp-	
M1	1120-0904	1	Meter: 0 - 5 microamps	-hp-	
Q1	1854-0039	1	TSTR: si NPN 2N3053	04713	2N3053
Q2	1853-0016	1	TSTR: si PNP 2N3638	04713	2N3638
Q3	1854-0003	1	TSTR: si NPN	01295	SM0843
R1	0684-6801	1	R: fxd comp 68 ohms 10% 1/4 W	CB6801	obd
R2 thru R11			NSR: part of A 1, A2, and A3		
R12	0757-0346	1	R: fxd flm 10 ohms 1% 1/8 W	-hp-	
R13	0757-0386	1	R: fxd flm 24.3 ohms 1% 1/2 W	91637	CMF-1/10-32 T-1
R14	0757-0397	1	R: fxd flm 68.1 ohms 1% 1/8 W	14674	C4 T-0
R15	0698-4420	1	R: fxd flm 226 ohms 1% 1/8 W	14674	C4
R16	0757-0419	1	R: fxd flm 681 ohms 1% 1/8 W	14674	C4 T-0
R17	0698-4433	1	R: fxd flm 2.26 kilohms 1% 1/8 W	14674	C4 T-0
R18	0698-4470	1	R: fxd flm 6.98 kilohms 1% 1/8 W	14674	C4 T-0
R19	06984486	1	R: fxd flm 24.9 kilohms 1% 1/8 W	14674	C4 T-0
R20	0698-4503	1	R: fxd flm 66.5 kilohms 1% 1/8 W	14674	C4 T-0
R21	0683-1345	1	R: fxd comp 130 kilohms 5% 1/4 W	01121	CB1345
R22	0698-7683	1	R: fxd comp 43 megohms 5% 1/2 W	01121	EB4365
R23			Not assigned		
R24	0684-1021	4	R: fxd comp 1000 ohms 10% 1/4 W	01121	CB1021
R25	0684-1051	2	R: fxd comp 1 megohm 10% 1/4 W	01121	CB1051
R26	0687-1031	1	R: fxd comp 10 kilohms 10% 1/2 W	01121	EB1031
R27	0684-1541	2	R: fxd comp 150 kilohms 10% 1/4 W	01121	CB 1541
R28	0683-7515	1	R: fxd comp 750 ohms 5% 1/4 W	01121	CB7515
R29	0684-1541		R: fxd comp 150 kilohms 10% 1/4 W	01121	CB1541
R30	0687-5621	1	R: fxd comp 5.6 kilohms 10% 1/2 W	01121	EB5621
R31	0757-0353	1	R: fxd flm 249 kilohms 1% 1/2 W	91637	MFF-1/2-10 T-1
R32	0698-4965	1	R: fxd flm 324 kilohms 1% 1/2 W	91637	MFF-1/2-10 T-1
R33	0698-4712	1	R: fxd flm 12.4 kilohms 1% 1/4 W	91637	MFF -1/8-32 T-1
R34	0684-4701	2	R: fxd comp 47 ohms 10% 1/4 W	01121	CB4701
R35	06874731	1	R: fxd comp 47 kilohms 10% 1/2 W	01121	EB4731
R36	0686-9115	1	R: fxd comp 910 ohms 5% 1/2 W	01121	EB9115
R37	0684-4711	4	R: fxd comp 470 ohms 10% 1/4 W	01121	CB4711
R38 thru R40			Not assigned		
R41 thru R44			R: fxd flm 2 kilohms 1% 1/8 W	14674	C4 T-O
R45	0757-0327	1	R: fxd flm 499 kilohms 1% 1/4 W	91637	MFF-1/8-32, T-1
R46	2100-0331	1	R: var 5 kilohms 10% ww 1.5 W	79727	E-870
R47	0689-3935	1	R: fxd comp 39 kilohms 5% 1 W	01121	GB3935
R48	0684-4711		R: fxd comp 470 ohms 10% 1/4 W	01121	CB4711
R49	0698-4594	1	R: fxd flm 487 ohms 1% 1/4 W	91637	MFF-1/8-32 T-1
R50	0684-5631	1	R: fxd comp 56 kilohms 10% 1/4 W	01121	CB5631
R51	0757-0982	1	R: fxd flm 245 kilohms 1% 1/2 W	91637	MFF-1/2-10 T-1
R52	0698-0058	1	R: fxd flm 4.02 kilohms 1% 1/4 W	91637	MFF-1/8-32 T-1
R53 thru R 59			Not assigned		
R60	0683-2015	1	R: fxd comp 200 ohms 5% 1/4 W	01121	CB2015



Table 6-1. Replaceable Parts (Cont'd)

REFERENCE DESIGNATOR	-hp- PART NO.	TQ	DESCRIPTION	MFR.	MFR. PART NO.	
R61	0757-1039	1	R: fxd flm 45 ohms 1% 1/4 W	14674	C5 T-0	obd
R62	0757-1047	1	R: fxd flm 90 ohms 1% 1/4 W	19701	MF52C T-0	
R63	2100-0328	1	R: var 500 ohms 10% ww 1.5 W	79727	E-870	obd
R64	2100-0270	1	R: var 50 ohms 10% ww 2 W	12697	obd	
R65	0684-2711	1	R: fxd comp 270 ohms 10% 1/4 W	01121	CB2711	
R66	0684-4701		R: fxd comp 47 ohms 10% 1/4 W	01121	CB4701	
R67	0812-0015	1	R: fxd prec 8 ohms 3% ww 3 W	91637	RS2B-95	
R68	0757-1040	1	R: fxd flm 50 ohms 1% 1/4 W	14674	C5T-0	obd
R69	2100-1560	1	R: var 30 ohms 10% ww 1.5 W	11236	110	
R70	0684-1001	1	R: fxd comp 10 ohms 10% 1/4 W	01121	CB1001	
R71	0764-0028	1	R: fxd 100 kilohms 5% 2 W	14674	C-42S	obd
R72			Not assigned			
R73	0764-0003	1	R: fxd 3.3 kilohms 5% 2 W	14674	C-42S	obd
R74	0698-4746	1	R: fxd flm 53.6 kilohms 1% 1/4 W	91637	MFF-1/8-32 T-1	obd
R75	0698-4711	1	R: fxd flm 11.8 kilohms 1% 1/4W	91637	MFF-1/8-32 T-I	obd
R76	0811-0007	1	R: fxd prec 10 kilohms 1% ww 5 W	91637	RS5-78	
R77	0684-6821	1	R: fxd comp 6.8 kilohms 10% 1/4 W	01121	CB6821	
R78	0698-4953	1	R: fxd flm 124 kilohms 1% 1/2 W	91637	MFF-1/2-10 T-1	obd
R79	0684-1021		R: fxd comp 1000 ohms 10% 1/4 W	01121	CB 1021	
R80			Not assigned			
R81	0683-6225	1	R: fxd 6.2 comp kilohms 5% 1/4 W	01121	CB6225	
R82	2100-0197	1	R: var 20 kilohms/2000 ohms ww	11237	C252-45	
R83			Not assigned			
R84	2100-0282	1	R: var 2 kilohms 20% ww 1.5 W	79727	E-870	
R85	0684-5621	1	R: fxd comp 5.6 kilohms 10% 1/4 W	01121	CB5621	
R86	0684-1531	1	R: fxd comp 15 kilohms 10% 1/4 W	01121	CB1531	
R87 thru R90			Not assigned			
R91	0698-4931	1	R: fxd flm 32.4 kilohms 1% 1/2 W	91637	MFF-1/2-10 T-1	obd
R92	2100-0094	2	R: var comp 50 kilohms 30%	11236	UPM 7ORE	obd
R93	0684-1011	2	R: fxd comp 100 ohms 10% 1/4 W	01121	CB1011	
R94, R95	0684-1021		R: Fxd comp 1000 ohms 10% 1/4 W	01121	CB1021	
R96	0684-4711		R: Fxd comp 470 ohms 10% 1/4 W	01121	CB4711	
R97	0684-1011		R: Fxd comp 100 ohms 10% 1/4 W	01121	CB1011	
R98	2100-0394	1	R: var 300 ohms 20% ww 1.5 W	79727	E-870	obd
R99	0698-3647	1	R: fxd 15 kilohms 5% 2 W	14674	FP-2	obd
R100, R101	0690-1041	2	R: fxd comp 100 kilohms 10% 1 W	01121	GB 1041	
R102	0811-0041	1	R: fxd prec 169 ohms 1% ww 4 W	91637	RS2-64	obd
R103			Not assigned			
R104	0684-2251	1	R: fxd comp 2.2 megohm 10% 1/4 W	01121	CB2251	
R105	0684-4711		R: fxd comp 470 ohms 10% 1/4 W	01121	CB4711	
R106	0757-0857	1	R: fxd 82.5 kilohms 1% 1/2 W	91637	MFF-1 /2-10 T-1	obd
R107	0698-4153	1	R: fxd flm 9.31 kilohms 1% 1/2 W	75042	CEC, T-O	obd
R108	0698-4793	1	R: fxd flm 402 kilohms 1% 1/4 W	91637	MFF-1/8-32 T-1	obd
R109	2100-0094		R: var comp 50 kilohms 30%	11236	UPM 7ORE	obd
R110	0698-4772	1	R: fxd flm 178 kilohms 1% 1/4 W	91637	MFF-1 /8-32 T-1	obd
R111, R112	0683-0475	2	R: fxd comp 4.7 ohms 5% 1/4 W	01121	CB47G5	
R113	0687-3331	1	R: fxd comp 33 kilohms 10% 1/2 W	01121	EB3331	
R114	0684-1041	1	R: fxd comp 100 kilohms 10% 1/4 W	01121	CB1041	
R115	0698-4752	1	R: fxd flm 84.5 kilohms 1% 1/4 W	91637	MF F-1 /8-32 T-1	obd
R116	0684-1051		R: fxd comp 1 megohm 10% 1/4 W	01121	CB1051	
R117 thru R120	0764-0006	4	R: fxd 18 kilohms 5% 2 W	14674	FP-2	
S1	00428-61901	1	Assembly: Range Switch (incl. resistors)	-hp-		
S2	3101-0001	1	Switch: toggle SPST 3A 250 vdcw	04009	80994-HB	
S3	3101-0018	1	Switch: toggle (momentary) SPST	OOLAF	8906K499	
S4			Not assigned			
S5	3101-1234	1	Switch: slide DPDT	82389	11A-1242A	
T1			Not assigned			
T2	9100-1481	1	Detector: signal trans.	-hp-		
T3	9100-1483	1	Gate transformer	-hp-		
T4	9100-1484	1	Zero balance trans	-hp-		
T5	9100-1485	1	Coil: osc.	-hp-		

Table 6-1. Replaceable Parts (Cont'd)

REFERENCE DESIGNATOR	-hp- PART NO.	TQ	DESCRIPTION	MFR.	MFR. PART NO.
T6	9100-1486	1	Transformer: head drive	-hp-	
T7	9100-3228	1	Transformer: power	-hp-	
V1, V2	1923-0017	3	Tube: electron 6AH6	33173	6AH6
V3, V4			Not assigned		
V5	1923-0017		Tube: electron 6AH6	33173	6AH6
V6, V7	1932-0022	2	Tube: electron 6DJ8	73445	obd
V8	5080-0041	1	Tube: electron selected 12AU7	-hp-	
V9	1921-0010	1	Tube: electron 12B4A miniature 9 pin	33173	12B4A
V10	1923-0021	1	Tube: electron 6AU6 miniature 7 pin	33173	6AU6A
W1	8120-1348	1	Cable: AC power	-hp-	
			<b>MISCELLANEOUS</b>		
	428A-1C	1	Dust Cover (rack only)	-hp-	
	428A-21A	1	Probe Assembly (see Figure 6-1 )	-hp-	
	428A-83A	1	Escutcheon	-hp-	
	428B-2A	1	Panel (cabinet only)	-hp-	
	428B-2R	1	Panel (rack only)	-hp-	
	428B-44	1	Assembly: cabinet	-hp-	
	0403-0004	4	Bumper: rubber	OOCMM	obd
	1440-0002	1	Handle: leather	0000Z	obd
	1490-0015	1	Bail: cabinet tilt	OOLAG	obd
	5040-0616	2	Detent: cabinet bail	-hp-	
	00428-66501	1	Assembly: P .C. Board	-hp-	
	5020-0653	1	Bezel	-hp-	
	00428-26501	1	Board: P.C.	-hp-	
	0330-0029	1	Boot (rack only)	76545	62 obd
	8520-0017	1	Brush: nylon	OOLAH	obd
	1410-0052	1	Bushing: potentiometer	32016	obd
	2110-0269	2	Fuse: clip	91506	6008-32CN
	0510-0748	1	Fuse: holder	75915	357002
	1205-0011	1	Heat sink	98978	TXBF-032-025B obd
	0370-0822	1	Knob: round, brown	-hp-	
	0370-0031	1	Knob: 1" dia. black conc.	-hp-	
	0370-0035	1	Knob: bar 1" dia. black	-hp-	
	0370-0064	1	Knob: 3/4" dia. red w/arrow	-hp-	
	0370-0823	1	Knob: red (for R63)	-hp-	
	0370-0824	1	Knob: orange (for R69)	-hp-	
	0370-0825	1	Knob: yellow (for R46)	-hp-	
	0370-0826	1	Knob: green (for R98)	-hp-	
	7121-0192	1	Nameplate (cabinet only)	91345	obd
	2950-0034	1	Nut: hexagonal	91961	obd
	1200-0062	4	Socket: 9 pin miniature tube	71785	121-51-11-060
	1200-0083	4	Socket: 7 pin miniature tube	91662	05-0730-02
	3100-0268	1	Switch: rotary	76854	216481-HZ obd
	00428-90003	1	Operating and Service Manual	-hp-	

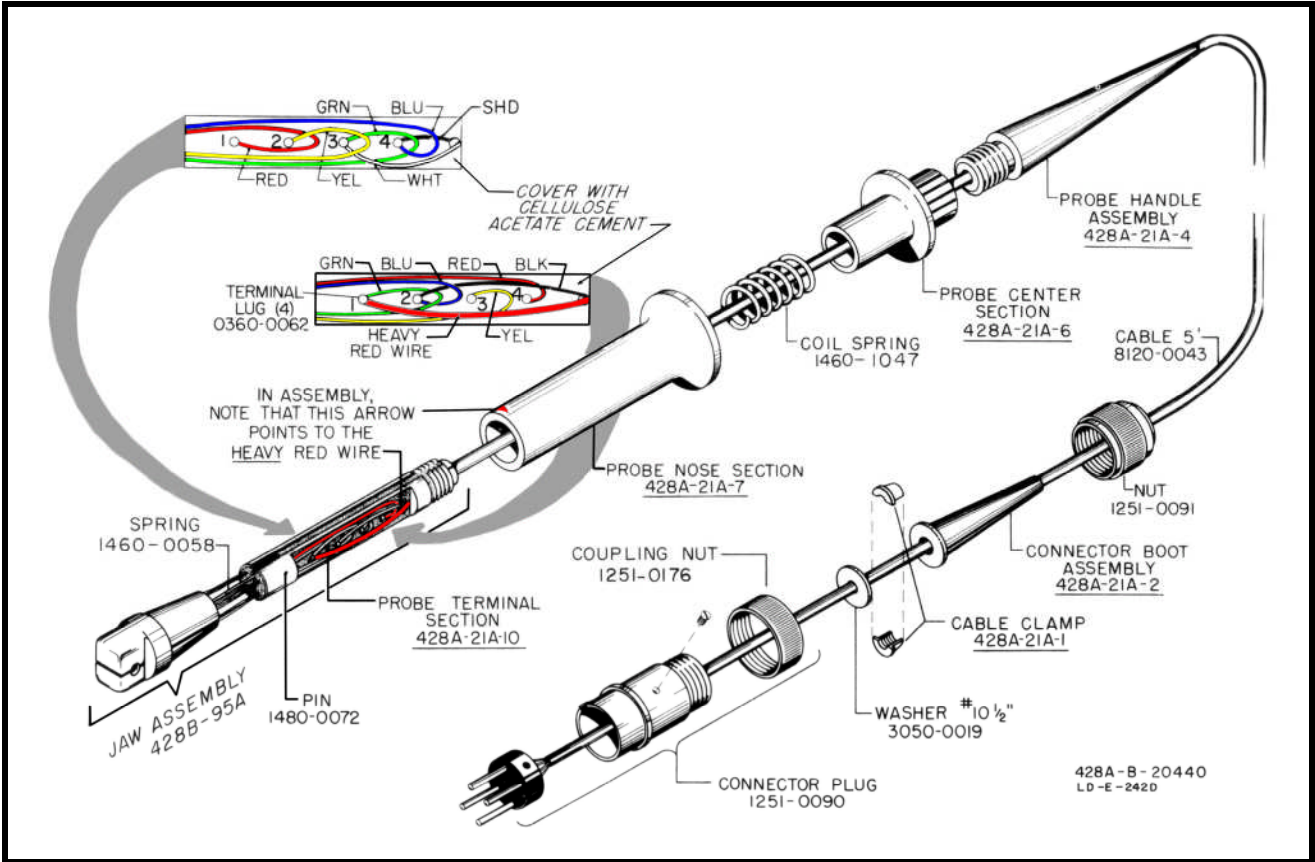

Figure 6-1. Parts Breakdown, current probe.

## SECTION VII

### CIRCUIT DIAGRAMS

#### 7-1. INTRODUCTION.

7-2. This section contains the circuit diagrams necessary for the operation and maintenance of the Model 428B Clip-on DC Milliammeter. Included are a block diagram, schematics and component location diagrams.

#### 7-3. BLOCK DIAGRAM.

7-4. The block diagram shows the relationship between the assemblies of the instrument. Signal flow between assemblies and significant portions of assemblies as well as major feedback paths are shown. The block diagram is used to develop an understanding of the basic theory of operation.







#### 7-5. SCHEMATIC DIAGRAMS.

7-6. The circuitry contained within each assembly is shown in the schematic diagrams. These diagrams are used to develop an understanding of the detailed theory of operation of each assembly and as an aid in isolating troubles within an assembly.

#### 7-7. COMPONENT LOCATION DIAGRAMS.

7-8. The component location diagrams show the physical location of parts mounted on an assembly. Each part is identified by a reference designator.

#### SCHEMATIC NOTES

-  AC ground: referred to the center tap of T4.
-  Detector reference: referred to V6 bias source.
-  Chassis ground.
-  Earth ground.
- † Waveforms where amplitude and waveform change with setting of ZERO control.
- \* Component selected at factory. Average value given.
-  Denotes main signal path.
-  Denotes feedback path.

#### MEASUREMENT CONDITIONS.

Line voltage: 115 V, 60 Hz  
 Range: 100 mA  
 Input: 100 mA

All voltages were measured with a high input impedance electronic voltmeter. A 10 megohm oscilloscope probe was used to measure the waveforms. The oscilloscope should be externally synchronized from pin 2 of V7 (through a 47  $\mu$ F capacitor to avoid disturbing the circuit).

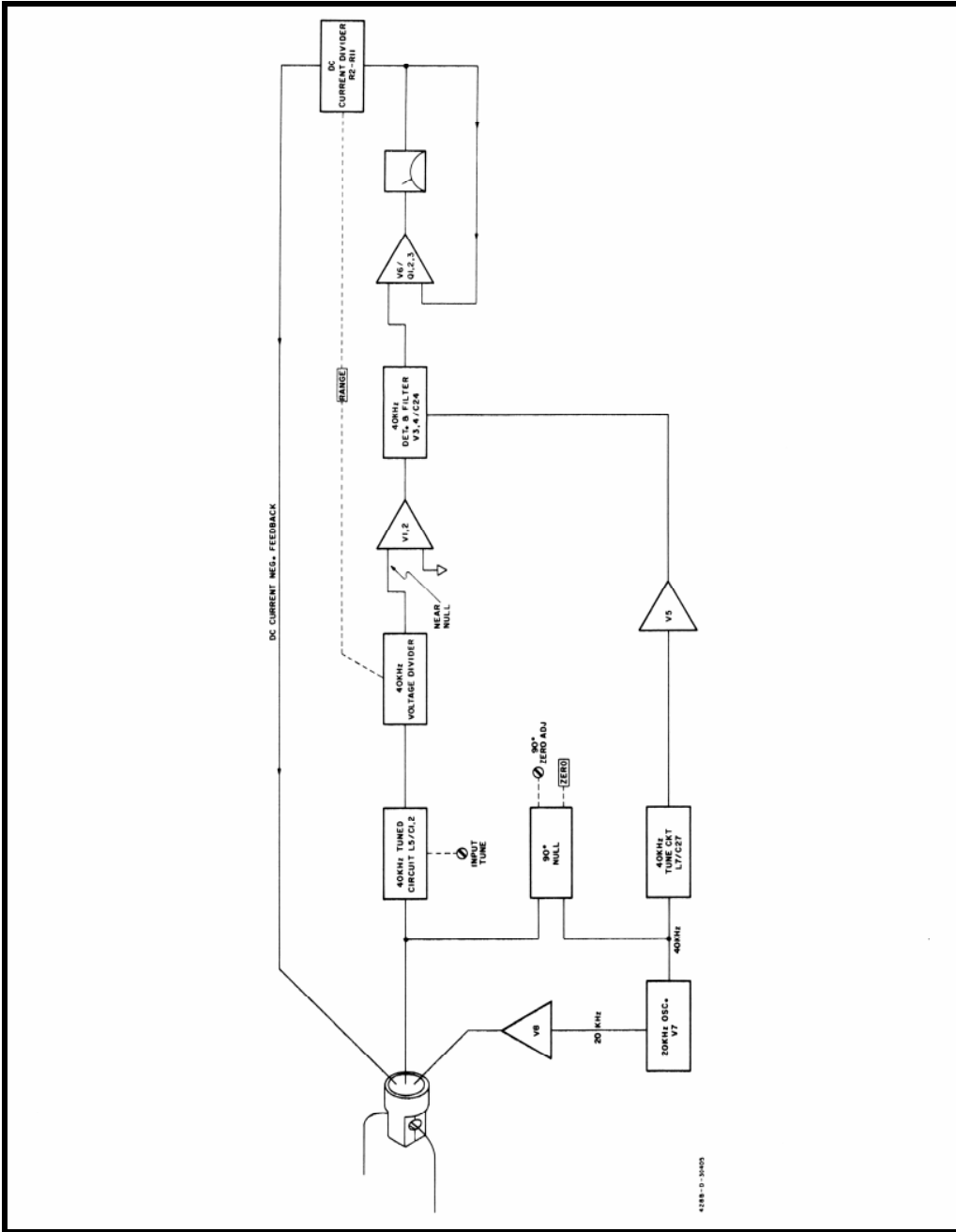
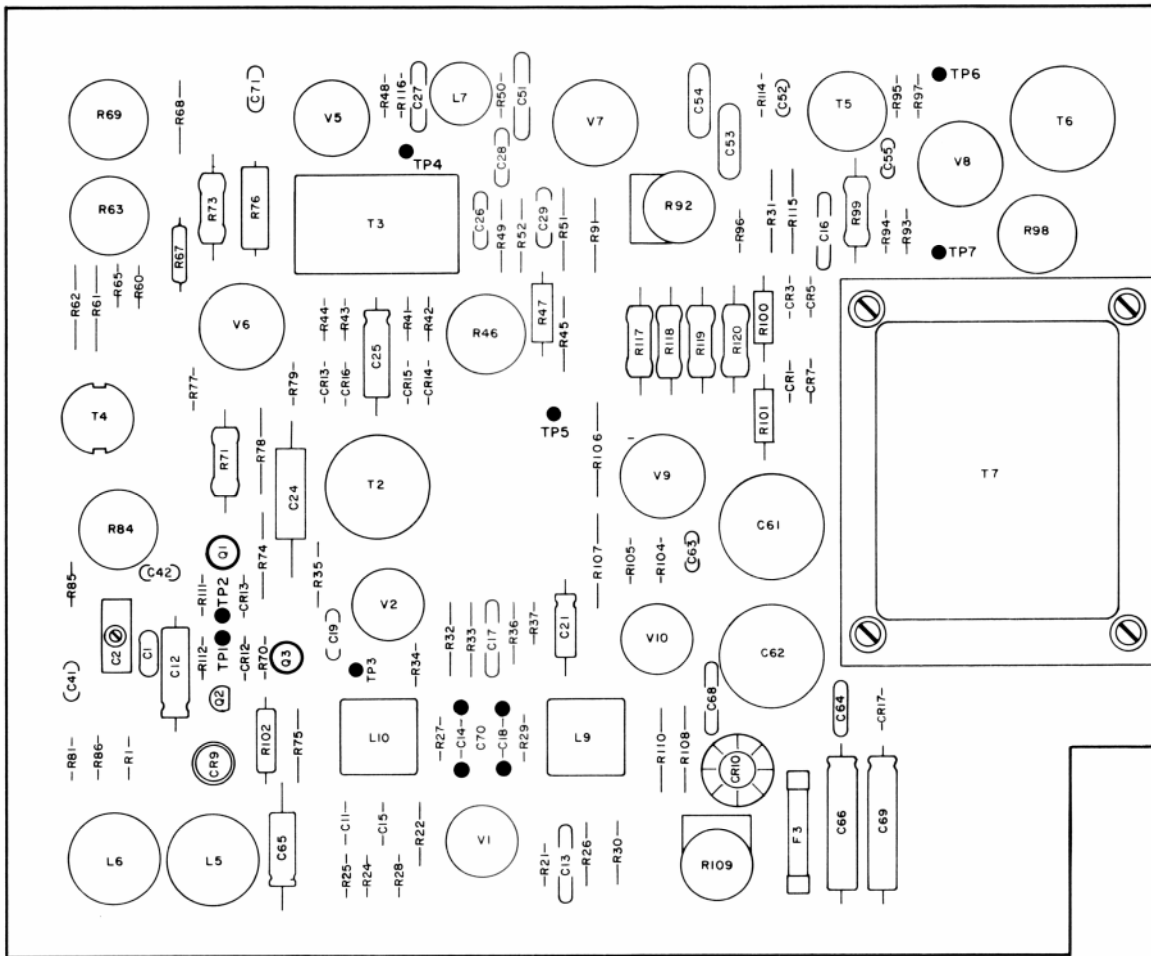
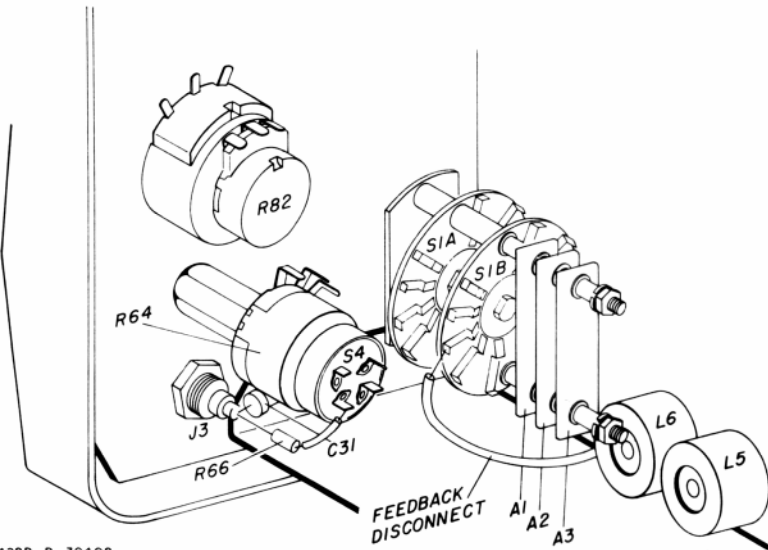

Figure 7-1. Block Diagram.



428B-C-30404

Figure 7-2. Component Locator For Circuit Board Part No. 00428-66501



428B-B-30408

Figure 7-3. Front Panel Component Locator.

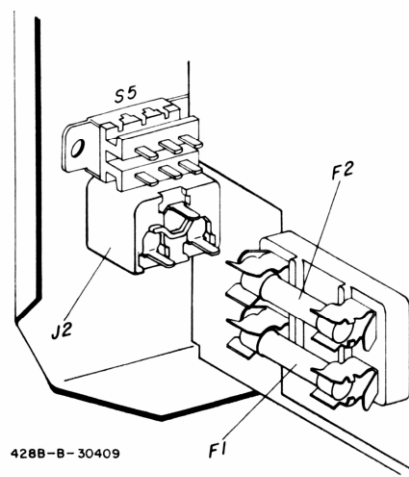

428B-B-30409

Figure 7-4. Rear Panel Component Locator.

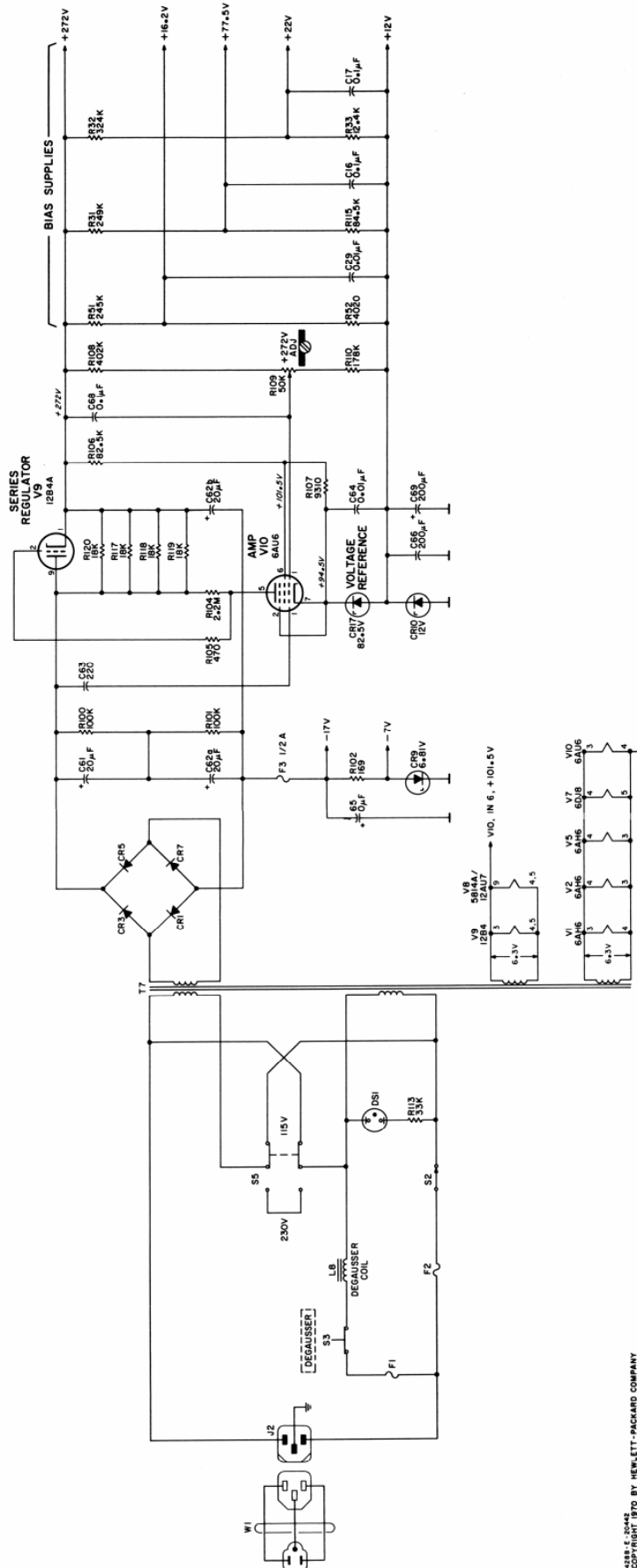

Figure 7-5. Power Supply.

428B-E-2044Z  
 COPYRIGHT 1970 BY HEWLETT-PACKARD COMPANY

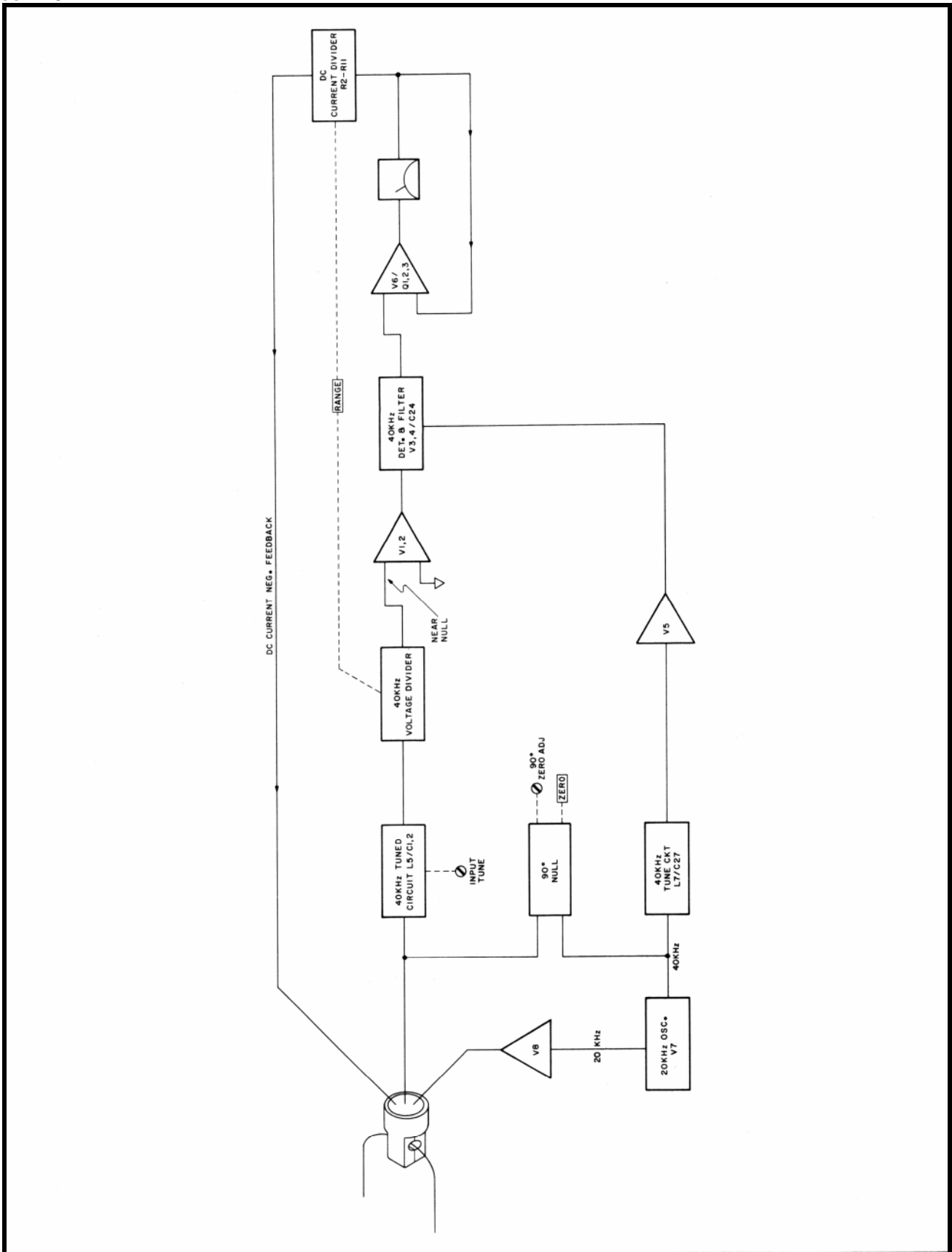

Figure 7-6. Block Diagram.



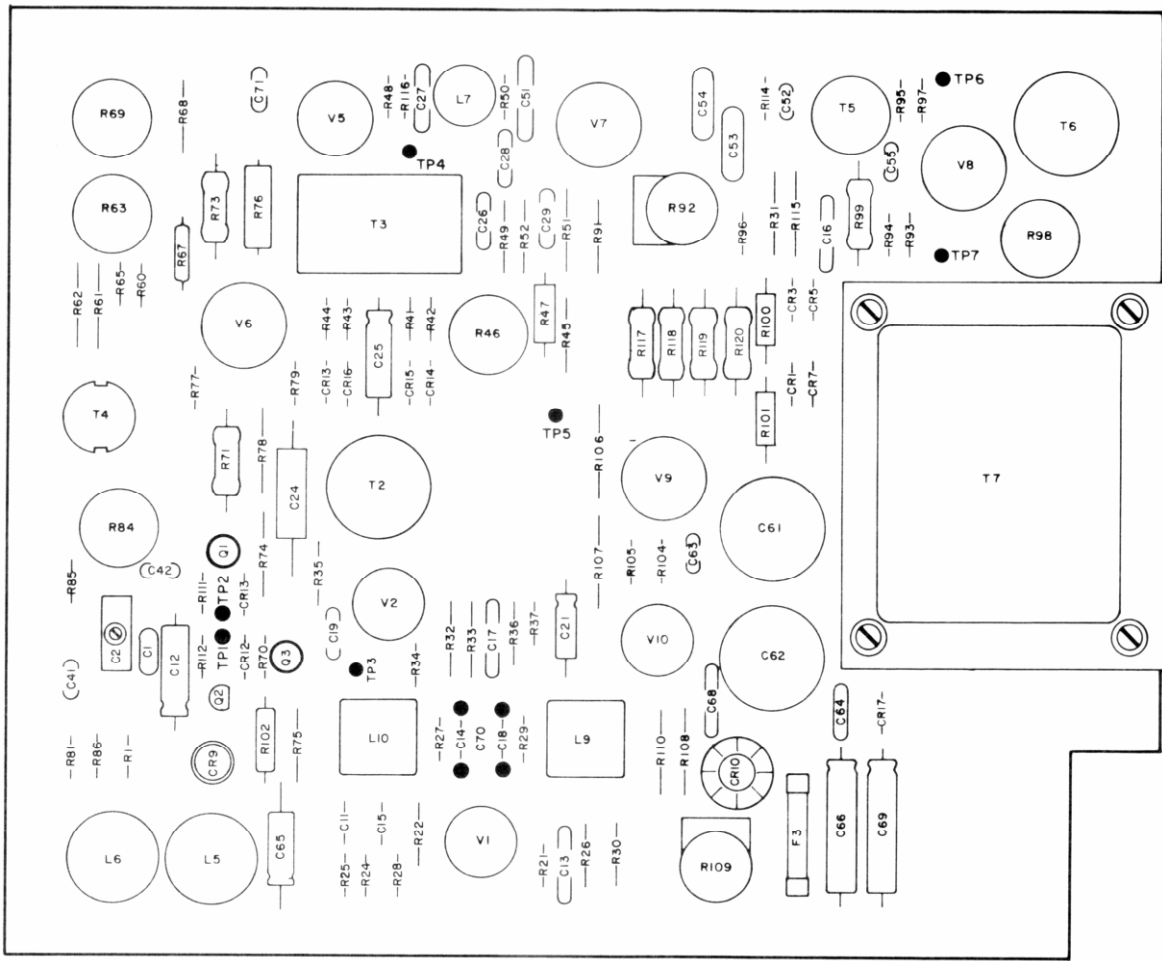

Figure 7-7. Component Locator for Circuit Board Part No. 00428-66501

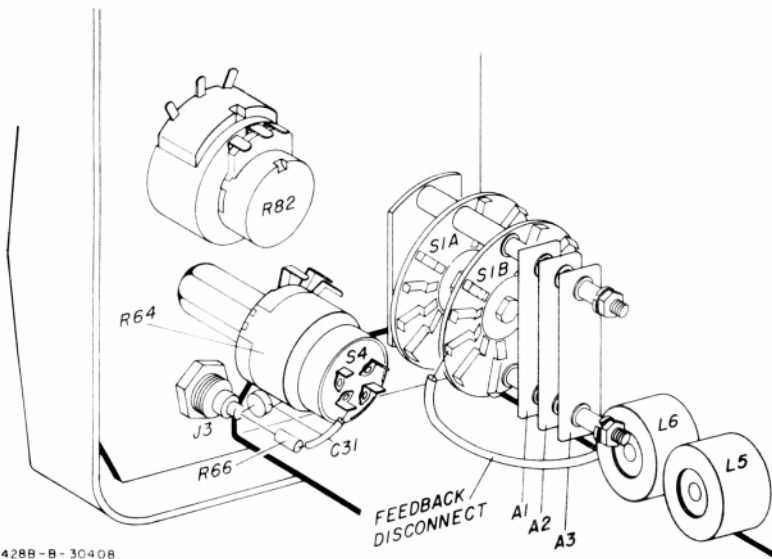

Figure 7-8. Front Panel Component Locator.

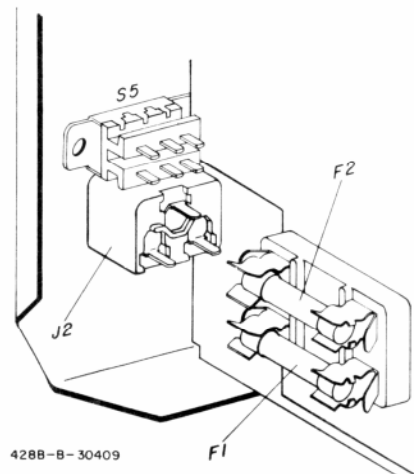

Figure 7-9. Rear Panel Component Locator.

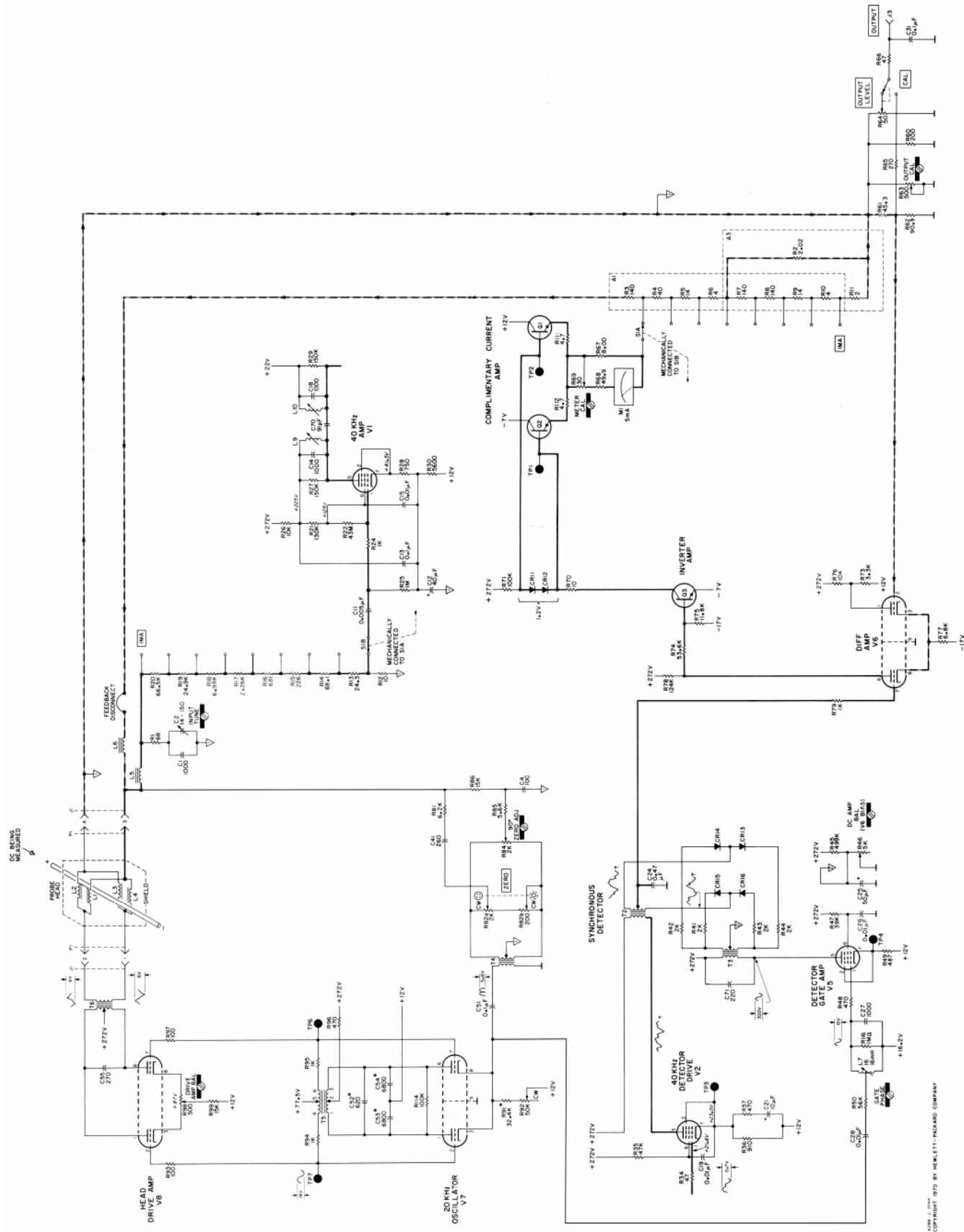

Figure 7-10. Metering Circuit

(Note: This schematic has been chopped and resectioned to reduce the 11x30 page to better fit on 8½x11 paper)

## APPENDIX A

### MANUAL BACKDATING CHANGES

A-1. The changes which appear in this Appendix make this manual applicable to those 428B Clip-on DC Milliammeters which bear serial number prefixes of 601- or below.

A-2. Schematic diagrams, photographs, and a parts list for the earlier instruments have been included in this Appendix.

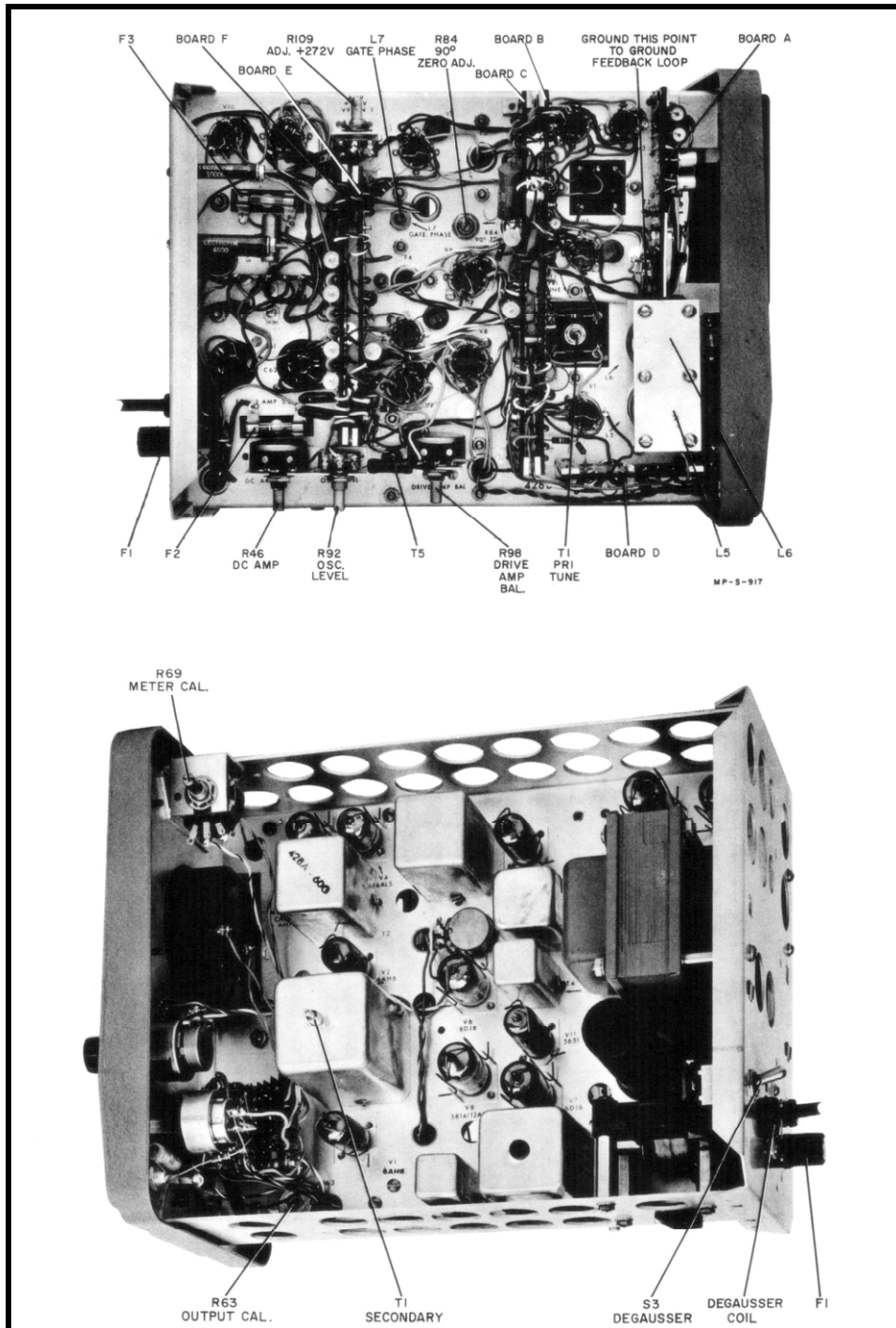

**Figure A-1. 428B Side Views.**

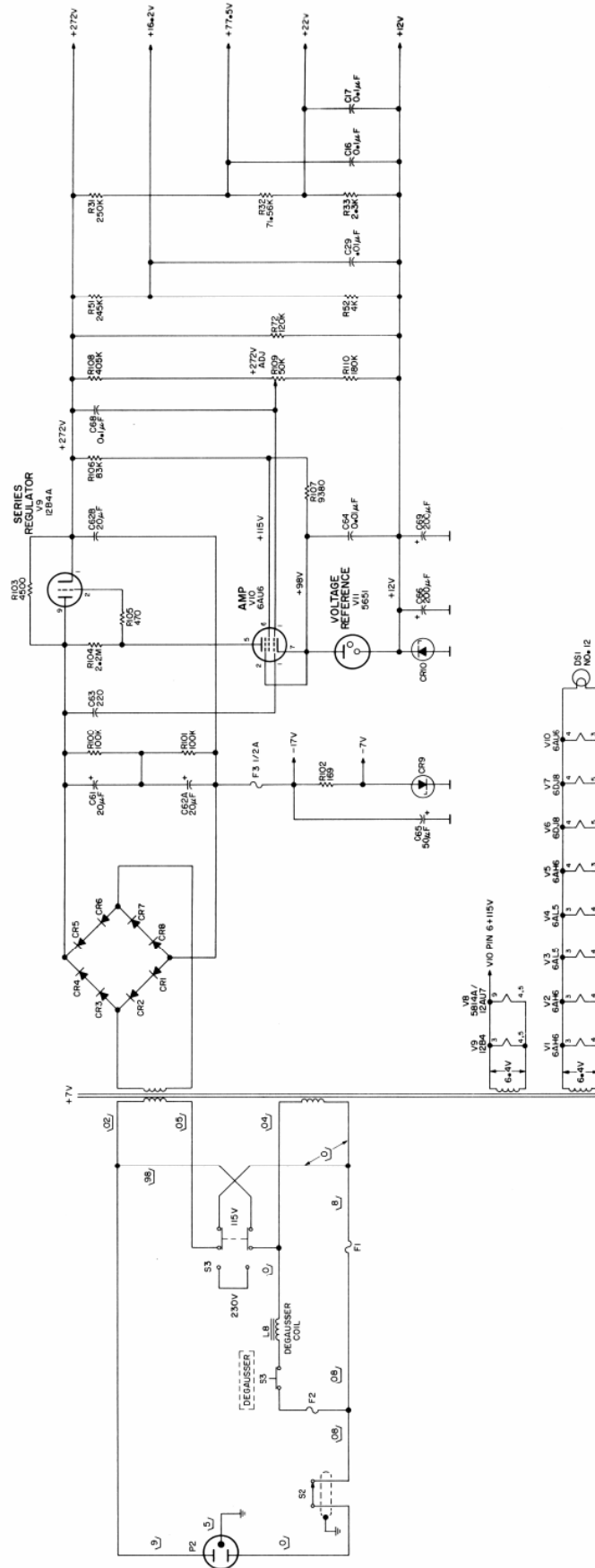

© 1969 BY HEWLETT-PACKARD COMPANY

Figure A-2 Backdating Schematics for 428B

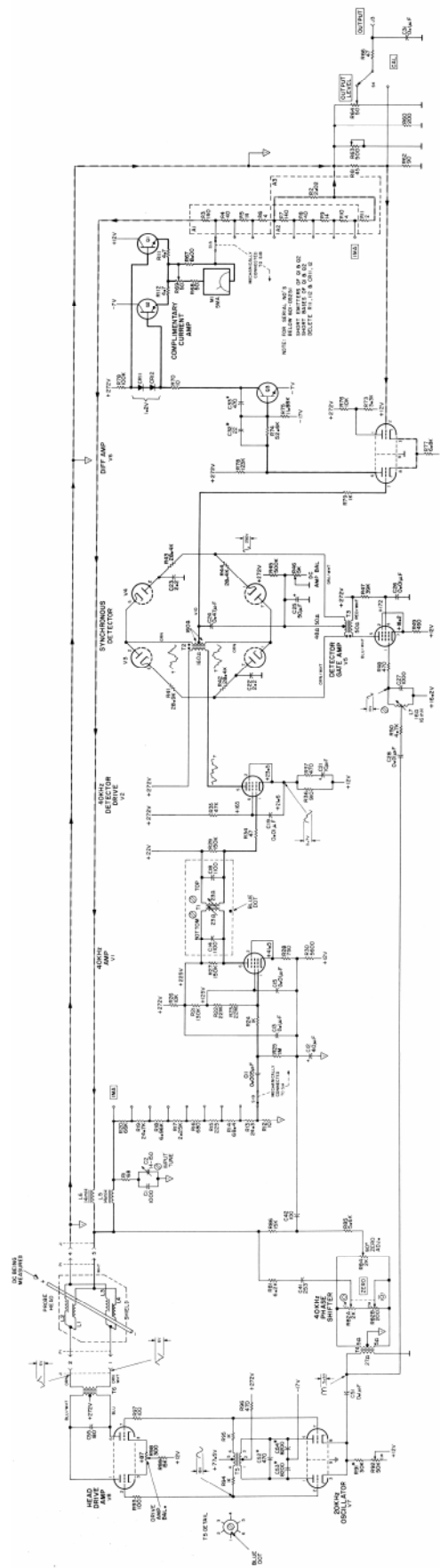

Figure A-3 Backdating Schematics for 428B

Model 428B

Circuit Reference	Stock No.	Description #
A1, 2	428B-26A	Assembly: ww resistor, A1 includes, R3 thru R6 A2 includes, R7 thru R10
A3	428B-26B	Assembly: ww resistor, includes R2, 11
C1	0140-0099	fxd, mica, 1K pf +1%, 500 vdcw
C2	0131-0004	var, mica, 14-150 pf, 175 vdcw
C3 thru C10		Not Assigned
C11	0150-0014	fxd, cer, 5K pf, 500 vdcw
C12	0180-0050	fxd, elect, 40 uf -15% + 100%, 50 vdcw
C13	0170-0022	fxd, my, 0.1 uf +20%, 600 vdcw
C14		nsr, part of T1 assembly
C15	0150-0012	fxd, cer, 10K pf +20%, 1000 vdcw
C16, 17	0170-0019	fxd, my, 0.1 of +5%, 200 vdcw
C18		nsr, part of T1 assembly
C19	0150-0012	fxd, cer, 10K pf +20%, 1000 vdcw
C20		Not Assigned
C21	0180-0059	fxd, elect. 10 uf -10% + 100%, 25 vdcw
C22, 23	0150-0015	fxd, TiO <sub>2</sub> 2.2 pf +10%, 500 vdcw 2
C24	0170-0078	fxd, my, 0.47 uf +5%, 150 vdcw
C25	0180-0058	fxd, elect, 50 of -10% + 100%, 25 vdcw
C26	0150-0012	fxd, cer, 10K pf ±20% 1000 vdcw
C27	0140-0099	fxd, mica, 1K pf +1%, 500 vdcw
C28, 29	0150-0012	fxd, cer, 10K pf +20%, 1000 vdcw
C30		Not Assigned
C31	0170-0019	fxd, my, 0.1 of +5%, 200 vdcw
C32	0140-0034	fxd, mica, 22 pf +5%, 500 vdcw
C33 thru C40		Not Assigned
C41	0140-0108	fxd, mica, 253 pf +2%, 300 vdcw
C42	0140-0041	fxd, mica, 100 pf +5%, 500 vdcw
C43 thru C50		Not Assigned
C51	0170-0019	fxd, my, 0.1 of +5%, 200 vdcw
C52	0140-0149	fxd, mica, 470.pf +5%, 300 vdcw
C53, 54	0140-2102	fxd mica, 8.2K*pf +2%, 500 vdcw
C55	0140-0147	fxd, mica, 180 pf +5%, 500 vdcw
C56 thru C60		Not Assigned
C61	0180-0011	fxd, elect, 20 uf 450 vdcw
C62A/B	0180-0012	fxd elect, 2 sect, 20 of sect 450 vdcw
C63	0140-0031	fxd, mica, 220 pf +10%, 500 vdcw

Reference		
C64	0150-0012	fxd cer, 10K pf +20%, 1000 vdcw
C65	0180-0058	fxd, elect, 50uf -10% + 100%, 25 vdcw
C66	0180-0104	fxd, elect, 200 µf 15 vdcw
C67		Not Assigned
C68	0170-0022	fxd, my, 0.1 pf +20%, 600 vdcw
C69	0180-0104	fxd, elect, 200 µf, 15 vdcw
CR1 thru CR8	1901-0028	Diode, Si
CR9	1902-0013	Diode, Si
CR10	1902-0014	Diode, Si
DS1	2140-0012	Lamp: indicating, #12, 2 pin base
F1, 2	2110-0007	Fuse: 1 amp, s-b ( F1 115 V operation)
	2110-0008	Fuse: 1/2 amp, s-b (F1 230 V operation)
F3	2110-0012	Fuse: 1/2 amp
J1	1251-0089	Connector: female, 4 pin
J2		Not Assigned
J3	1250-0118	Connector: BNC, female
L1 thru L4		nsr; part of probe assembly (see misc.)
L5, 6	428B-60K	Assembly, choke
L7	9140-0049	Inductor: var, 16 mh
L8	9110-0025	Inductor: degaussing
MI	1120-0116	Meter: 0-5 ma, 6-10 ohms
P1	1251-0090	Connector: male, 4 pin
P2	8120-0050	Cable, power
Q1	1854-0039	Transistor: Si NPN 2N3053
Q2	1853-0016	Transistor: Si PNP 2N3638
Q3	1854-0003	Transistor: 2N1564
R1	0687-6801	fxd, comp, 68 ohms ±10%, 1/2 W
R2		nsr; part of A3 assembly
R3 thru R10		nsr; part of A1, A2 assembly
R11		nsr; part of A3 assembly
R12	0727-0335	fxd, dep c, 10 ohms +10%, 1/2 W
R13	0757-0002	fxd, mfg, 24.3 ohms ±1% 1/2 W
R14	0727-0035	fxd, dep c, 68.4 ohms ±1/2%, 1/2 W
R15	0727-0060	fxd, dep c, 225 ohms ±1%, 1/2 W
R16	0727-0085	fxd, dep c, 680 ohms ±1%, 1/2 W
R17	0727-0120	fxd, dep c, 2250 ohms ±1%, 1/2 W
R18	0727-0145	fxd, dep c, 6960 ohms ±1%, 1/2 W
R19	0727-0178	fxd, dep c, 24.7K ohms ±1%, 1/2 W

Circuit	Stock No.	Description
---------	-----------	-------------

Circuit Reference-hp-	Stock No.	Description #
R20	0727-0198	fxd, dep c, 66K ohms ±1%, 1/2 W
R21	0686-1345	fxd, comp, 130K ohms ±5%, 1/2 W
R22, 23	0687-2261	fxd, comp, 22M ±10%, 1/2 W
R24	0687-1021	fxd, comp, 1K ohms ±10%, 1/2 W
R25	0687-1051	fxd, comp, 1M ±10%, 1/2 W
R26	0687-1031	fxd, comp, 10K ohms ±10%, 1/2 W
R27	0687-1541	fxd, comp, 150K ohms ±10%, 1/2 W
R28	0689-7515	fxd, comp, 750 ohms ±5%, 1 W
R29	0687-1541	fxd, comp, 150K ohms ±10%, 1/2 W
R30	0687-5621	fxd, comp, 5.6K ohms ±10%, 1/2 W
R31	0727-0226	fxd, dep c, 2 50K ohms ±1%, 1/2 W
R32	0727-0201	fxd, dep c, 71.56K ohms ±1%, 1/2 W
R33	0730-0032	fxd, dep c, 12. 3K ohms ±1%, 1 W
R34	0687-4701	fxd, comp, 47 ohms ±10%, 1/2 W
R35	0690-4731	fxd, comp 47K ohms ±10%, 1 W
R36	0689-9115	fxd, comp, 910 ohms ±5%, 1 W
R37	0687-4711	fxd, comp, 470 ohms ±10%, 1/2 W
R38 thru R40		Not Assigned
R41 thru R44	0727-0184	fxd, dep c, 28.4K ohms ±1%, 1/2 W
R45	0727-0244	fxd, dep c, 500K ohms ±1%, 1/2 W
R46	2100-0006	var, ww, 5K ohms ±10%, 2 W
R47	0689-3935	fxd, comp, 39K ohms ±5%, 1 W
R48	0687-4711	fxd, c .p, 470 ohms ±10%, 1/2 W
R49	0727-0075	fxd, dep c, 490 ohms ±1%, 1/2 W
R50	0687-4721	fxd, comp, 4.7K ohms ±10%, 1/2 W
R51	0730-0080	fxd, dep c, 245K ohms ±1%, 1 W
R52	0727-0132	fxd, dep c, 4K ohms ±1%, 1/2 W
R53 thru R59		Not Assigned
R60	0687-6811	fxd, comp, 680 ohms ±10%, 1/2 W
R61	0727-0021	fxd, dep c, 45 ohms ±1%, 1/2 W
R62	0727-0038	fxd, dep c, 90 ohms ±1%, 1/2 W
R63	2100-0022	var, ww, lin, 500 ohms ±20%, 1 W
R64	2 100-0270	var, ww, lin, 50 ohms ±10%, 2 W
R65	0687-2711	fxd, comp, 270 ohms ±10%, 1/2 W
R66	0687-4701	fxd, comp, 47 ohms ±10%, 1/2 W
R67	0812-0015	fxd, ww, 8 ohms ±3%, 2 W
R68	0727-0023	fxd, dep c, 50 ohms ±1%, 1/2 W

R69	2100-0002	var, ww, 50 ohms ±10%, 2 W
R70	0687-1001	fxd, comp, 10 ohms ±10%, 1/2 W
R71	0693-1041	fxd, comp, 100K ohms ±10%, 2 W
R72	0690-1241	fxd, comp, 120K*ohms ±10% 1 W
R73	0764-0003	fxd, mfg, 3300 ohms ±5%, 2 W
R74	0727-0196	fxd, dep c, 52. 6K ohms ±1%, 1/2 W
R75	0727-0163	fxd, dep c, 11. 88K ohms ±1%, 1/2 W
R76	0816-0008	fxd, ww, 10K ohms ±10%, 10 W
R77	0687-6821	fxd, comp, 6.8K ohms ±10%, 1/2 W
R78	0730-0072	fxd, dep c, 123K ohms ±1%, 1 W
R79	0687-1021	fxd, comp, 1K ohms ±10%, 1/w
R80		Not Assigned
R81	0686-6225	fxd, comp, 6.2K ohms ±5%, 1/2 W
R82A/B	2100-0197	var comp, dual pot, ±10%, 2 W R82A, 2K ohms R82B, 200 ohms
R83		Not Assigned
R84	2100-0153	var, comp, 2K ohms ±20% 1/3 W
R85	0687-5621	fxd, comp, 5.6K ohms ±10%, 1/2 W
R86	0687-1531	fxd, comp, 15K ohms ±10%, 1/2 W
R87 thru R90		Not Assigned
R91	0727-0195	fxd, dep c, 50K ohms ±1%, 1/2 W
R92	2100-0013	var, comp, lin, 50K ohms ±20%
R93	0687-1011	fxd, comp, 100 ohms ±10%, 1/2 W
R94, 95	0687-1021	fxd, comp, 1K ohms ±10%, 1/2 W
R96	0687-4711	fxd, comp, 470 ohms ±10%, 1/2 W
R97	0687-1011	fxd, comp, 100 ohms ±10%, 1/2 W
R98	2100-0038	var, ww, 300 ohms
R99	0767-0010	fxd, mfg, 15K ohms ±5%, 3 W
R100, 101	0690-1041	fxd, comp, 100K ohms ±10%, 1 W
R102	0811-0041	fxd, ww, 169 ohms ±1%, 3 W
R103	0819-0011	fxd, ww, 4.5K ohms ±10%, 20 W
R104	0687-2251	fxd, comp, 2.2M ±10%, 1/2 W
R105	0687-4711	fxd, comp, 470 ohms ±10%, 1/2 W
R106	0730-0063	fxd, dep c, 83K ohms ±1%, 1 W
R107	0727-0154	fxd, dep c, 9380 ohms ±1%, 1/2 W
R108	0727-0240	fxd, dep c, 405K ohms ±1%, 1/2 W
R109	2100-0013	var, comp, lin, 50K ohms ±20%

Circuit Reference	L Stock No.	Description#
-------------------	-------------	--------------



Model 428B

Circuit Reference	-hp- Stock No.	Description#
R110	0727-0218	fxd, dep c, 180K ohms $\pm$ 1%, 1/2 W
S1	428B-19A	Assembly: range switch, includes, R2 thru R20, R61, R62
S2	3101-0001	Switch: tog, SPST
S3	3101-0018	Switch: tog, SPST, momentary
S4		Not Assigned
S5	3101-0033	Switch, sl DPDT
T1	9120-0052	Assembly: transformer, interstage, includes, C14, C18
T2	428A-60G	Transformer, detector signal
T3	428A-60C	Transformer, gate
T4	428B-60J	Transformer, zero balance
T5	9120-0051	Transformer, osc
T6	428A-60D	Transformer, head drive
T7	9100-0104	Transformer, power
V1, 2	1923-0017	Tube, electron: 6AH6
V3, 4	1930-0013	Tube, electron: 6AL5
V5	1923-0017	Tube, electron: 6AH6
V6, 7	1932-0022	Tube, electron: 6DJ8 / ECC88
V8	1932-0029	Tube, electron: 12AU7
V9	1921-0010	Tube, electron: 12B4A
V10	1923-0021	Tube, electron: 6AU6
V11	1940-0001	Tube, electron: 5651
		<b>MISCELLANEOUS</b>
	428A-21A	Assembly: probe, includes L1 thru L4, P1
	428B-65C	Assembly: circuit board "C" includes R65, R67, P68
	428B-75H	Assembly: circuit board "A" includes C32, C66, C69, CR9, CR10, Q1 thru Q3, R70, R71, R74, R75, R102
	428B-75B	Assembly: resistor board "B" includes C13 R26, 27 C15 R35, 36 C21 R41, 42 C25 R45 R21 thru R23 R73
	428B-75C	Assembly: circuit board "C" includes C16, C17, C24, C41, C42, R30 thru R33 R43, R44 R77 thru R79, R81, R85, R86
	428B-75D	Assembly: resistor board "D" includes C1, C2 C11, C12 R1 R25

Circuit Reference	-hp- Stock No.	Description#
	428B-75E	Assembly: resistor board "E" includes C27 thru C29 C51 R47 thru R52 R72 R91 R94 thru R96
	428B-75F	Assembly: resistor board "F" includes C53, C54 C68 CR1 thru CR8 R106 R108 R110
	G-74AW	Knob: red, 3/4" w/arrow
	G-74J	Knob: black, 1", concentric shaft ZERO
	G-74N	Knob: bar, RANGE
	1200-0003	Socket, tube: 9 pin miniat
	1200-0017	Socket, tube: 7 pin miniat
	1400-0008	Fuseholder
	1400-0084	Fuseholder
	1450-0020	Jewel, pilot light
	8520-0017	Electric shaver brush
	1205-0011	Heat dissipater, semiconductor

**MANUAL CHANGES**

Manual Part No. 00428-90003

10 April 1974

## ▶ New or Revised Item

## ERRATA:

Pages 1-0 and 2-1. The power frequency should be 48 - 440 Hz.

Page 1-1. Delete Paragraph 1-5a (the 3528A is obsolete).

▶ Page 3-2, Paragraph 3-22. Change last sentence to read as follows:

"If the jaws mate properly, the zero set should stay within 0.2 mA, while rotating the probe head with respect to the earth's magnetic field (probe aligned in an East-West direction)."

▶ Page 3-2, Paragraph 3-35. Change the third sentence to read as follows: "With the RANGE switch at 1 mA, rotation of the closed probe should not vary the zero set more than 0.2 mA."

Pages 4-0,7-2 and 7-4. Change V3, V4 to CR13 through CR16.

Page 4-3, Paragraph 4-29. Change all "40" to "40 kHz".

Page 4-4, Figure 4-9. Change R87 to R81. Delete C12 and return C42 directly to common.

Paragraph 4-49. Delete the words "tube V11" and insert "Zener diodes CR10, CR17".

Page 5-0. Change the 50  $\Omega$  resistor to 0698-8155.

Change the recommended DC voltmeter to -hp- Model 3469B.

Add: Resistors (2), 10 K, 1 %, matched, for alignment, -hp- Part No. 0757-0442.

Page 5-1, Paragraph 5-2. Add: See the Performance Test Card at the end of this section."

▶ Page 5-1, Paragraph 5-11 c. Add the following sentence: "Point probe in an East-West direction."

Page 5-2. Set the OUTPUT LEVEL control to CAL for Paragraph 5-18.

▶ Page 5-3, Paragraph 5-24a. In second sentence, change reference to 0.1 mA to read 0.2 mA

▶ Page 5-3, Paragraph 5-28. Replace entire paragraph with the following:

5-28a. Connect an electronic dc voltmeter to test point 5 (Pin 1, V9) of the 428B. The voltage at this point should be  $272 \pm 6$  V; if not, adjust R 109 for 272 V.

b. Measure  $+12 \pm 1$  V dc between the cathode of CR 10 and ground.

c. Measure  $-7 \pm 1$  V dc between the anode of CR9 and ground.

▶ Page 5-3, Paragraph 5-32. Change C10 to L10. Change C14 to C18.

The 6.3 V filament supply is available at pin 4 or 5 of V6.

Page 5-3, Paragraph 5-32. Replace entire paragraph with the following:

5-32. Disconnect FEEDBACK DISCONNECT (See Figure 7-3); red wire. Place range switch in the 10 amp position. Adjust fine and course zero controls for center of travel. Adjust R46 for zero on front panel meter.

▶ Page 5-4, Paragraph 5-33. Replace entire paragraph with the following:

5-33. Reconnect FEEDBACK DISCONNECT.

▶ Page 5-4, Paragraph 5-42. Add to last sentence "(2.5 - 3.3 V rms)."

▶ Page 5-4, Paragraph 5-45. Add the following to sentence two: "... carrying 35 mA rms ac,  $f \leq 400$  Hz."

▶ Page 5-4, Paragraph 5-47. Replace the feedback disconnect before proceeding to Paragraph 5-48.

▶ Page 5-4, Paragraph 5-47. Add to last sentence: "(.2 V - .4 V peak)"

Para. 5-51. Replace the feedback disconnect before proceeding to Paragraph 5-52.

▶ Page 5-5, Paragraph 5-54. Replace entire paragraph with the following:

5-54. Preset the controls as follows:

- a. Set RANGE switch to 100 mA
- b. Adjust R84 for minimum ac at the wiper connection of R84. The reading should be less than 0.1 volts.
- c. Adjust R82 for minimum ac out at the wiper of R82a. The reading should be  $\leq 0.02$  volts.
- d. Thoroughly clean probe head jaws (See Paragraph 5-7),
- e. Degauss probe head (See Paragraph 3-29).

▶ Page 5-5, Paragraph 5-58. Remove Steps a and b. Re-letter Steps c to f to read a to d respectively. In newly designated Step d, Step d is now Step b; Step e is now Step c.

▶ Page 5-5. The following paragraph is added following Paragraph 5-58 to complete the adjustment procedure:

Model 428B

5-58.1. OUTPUT ADJUSTMENT.

5-58.2. A meter calibrator and a one kilohm resistor are required for his test.

- a. Place RANGE switch in 10 amp position and adjust R46 for zero volts DC  $\pm$  0.2 mV at the Output Level jack.
- b. Switch the 428B and the meter calibrator to the 100 mA range. Connect a test lead between the meter calibrator output leads and clip the 428B probe to the lead.
- c. Set the meter calibrator to 100 mA output and read full-scale on the 428B. Adjust R69 if necessary.
- d. Connect a voltmeter to the output jack of the 428B in parallel with the 1000 ohm resistor.
- e. The voltmeter should read 0.73 V  $\pm$  10m V. Adjust R63 if necessary.

Page 5-8, Paragraph 5-69. Replace V11 by Zener diodes CR10, CR17.

Page 6-2. Change CR13 through CR16 to 1906-0034, Duo-Quad, -hp-, for all replacements.

Change C63 part no. to 0160-2025.

Pages 6-2/6-3. Change C24, C52, C55, C70, and R60 to "starred" (selected) components.

Nominal values are as follows:

- C24, 0160-0138, .39  $\mu$ F, 200 Vdcw.
- C52, 0140-D178, 560 pF, 300 Vdcw.
- C55, 0140-0197, 180 pF, 300 Vdcw.

Page 6-3. M1 is a 0 - 5 mA meter.

Pages 6-3 and 7-5. Change R 15 to 216  $\Omega$ .

Page 6-4. R82 is 2 K/200 ohms.

Page 6-5. Part Numbers in the Operating and Service Manual are for blue instruments; part numbers for brown instruments are listed below.

00428-00204	Dust Cover (rack only)
00428-62101	Probe Assembly
00428-00201	Panel (cabinet only)
00428-00203	Panel (rack only)
00428-64401	Assembly: cabinet
5020-6849	Bezel

► Page 6-6, Fig. 6-1. Change Part No. of Coil Spring by probe nose section to 1460-0600 and change PIN of Cable Clamp by connector plug to 00428-41201.

Page 7-1. Note that resistors are in ohms and capacitors are in pF unless otherwise marked, and that selected ("starred") components marked with an asterisk may not even be present.

Page 7-3, figure 7-5. TP5 is connected to pin 1 of V9. Reverse F1 and F2.

Page 7-3, Figure 7-2; Page 7-5, Figure 7-7. Change CR13 (near TP2) to CR11.

Interchange: R26/R30; R27/R29 and C14/C18.

Page 7-5, Figure 7-10. R8 is 40 ohms. R68 is 50 ohms.

R61 is 45 ohms.

R62 is 90 ohms.

R 12 through R20 may be any mixture of the values shown on Pages 7-5 or A-D.

Nominal value of C52\* is 560 pF.

Nominal value of C55 \* is 180 pF.

C2 is 16 - 150 pF.

R91 is not a "starred" component; it is no longer a selected value.

Page 7-5/A-0. Add another contact to S1A as shown:



Page A-0. R41 is 28.4 K. Change R78 (near CR11) to R71. Add R65 between the junction of R61, R62 and 54 (as in Figure 7-10). Change R60 to R60\*. Change the LINE switch (230 V-115 V) from S3 to S5. Change the power transformer from +7v to T7. R33 is 12.3 K.

Page A-2. Add CR11, CR12 as on page 6-2.

Pages A-2, A-3. R 12 through R20 may be individually replaced by the parts shown on Page 6-3.

Page A-4. Add R111, R112 as on page 6-4.

CHANGE NO. 1: For Serial 0995A06603 and Greater.

Page 6-2. Add C33\*, 0140-0149 C: fxd 470 pF 300 V. Add C72\* 0160-0174 C: fxd .47  $\mu$ F 25 V.

Page 7-5. Add C33\*, 470 pF, between base and collector of Q3. Add C72\* .47  $\mu$ F between emitter and collector of Q3

00428-90003



PRINTED IN U.S.A.