

ICF-6800W



REVISED

Discard your ICF-6800W Service Manual previously issued.

*AEP Model
E Model
UK Model
Canadian Model
US Model*

For Service Manuals Contact
MAURITRON TECHNICAL SERVICES
8 Cherry Tree Rd, Chinnor
Oxon OX9 4QY
Tel: 01844-351894 Fax: 01844-352554
Email: enquiries@mauritron.co.uk

FM/AM MULTI-BAND RECEIVER

SPECIFICATIONS

Power Requirements: 120 V ac, 50/60 Hz (Canadian model)
110, 120, 220 or 240 V ac adjustable,
50/60 Hz (US, AEP, UK, E model)
9 V dc Battery size "D", 6 pcs
Car battery cord DCC-120 for 12 V car battery

Power Consumption: 7 W ac (US model)
9 W ac (AEP, UK, E, Canadian model)

Maximum Power Output: 1000 mW at 10 % distortion in dc operation

Speaker: Approx. 10 cm (4 inches) dia.

Dimensions: Approx. 453 (w) x 184 (h) x 227 (d) mm
17 3/8 (w) x 7 1/4 (h) x 9 (d) inches

Weight: Approx. 5.9 kg, 13 lb with batteries

Antennas: FM: telescopic antenna
SW: telescopic antenna
external antenna terminals (50 - 75 Ω)
UHF-type connector (50 - 75 Ω)
MW: built-in ferrite-rod antenna
external antenna terminals (low impedance)

Frequency Ranges: FM: 87.5 - 108 MHz (3.43 - 2.78 m)
MW: 530 - 1,605 kHz (566 - 187 m)
SW: 1.6 - 30 MHz (187.5 - 10 m)

SW sensitivity: -4 dBμ (0.63μV) at 1.6-30 MHz,
S+N/N = 6 dB, 30 % modulation, with
external antenna, NARROW

Selectivity (MW/SW and SSB/CW)

Band width \ Mode	MW/SW		SSB/CW
	WIDE	NARROW	
-6 dB	9kHz	4kHz	4kHz
-60 dB	18.5kHz	8.5kHz	8.5kHz

Input: TIMER (minijack) 1

Outputs: REC OUT (minijack) 1
output level: 0.8 mV (-60 dB)
output impedance: 1 kΩ
EARPHONE (minijack) 1
for 8 Ω earphone
HEADPHONES (stereo binaural jack) 1
for 8 Ω stereo or monaural headphones

SAFETY-RELATED COMPONENT WARNING!!

COMPONENTS IDENTIFIED BY SHADING AND MARK  ON THE SCHEMATIC DIAGRAMS, EXPLODED VIEWS AND IN THE PARTS LIST ARE CRITICAL TO SAFE OPERATION. REPLACE THESE COMPONENTS WITH SONY PARTS WHOSE PART NUMBERS APPEAR AS SHOWN IN THIS MANUAL OR IN SUPPLEMENTS PUBLISHED BY SONY.

ATTENTION AU COMPOSANT AYANT RAPPORT
À LA SÉCURITÉ !

LES COMPOSANTS IDENTIFIÉS PAR UN TRAMÉ ET UNE MARQUE  SUR LES DIAGRAMMES SCHEMATIQUES, LES VUES EXPLOSÉES ET LA LISTE DES PIÈCES SONT CRITIQUES POUR LA SÉCURITÉ DE FONCTIONNEMENT. NE REMPLACER CES COMPOSANTS QUE PAR DES PIÈCES SONY DONT LES NUMÉROS SONT DONNÉS DANS CE MANUEL OU DES SUPPLÉMENTS PUBLIÉS PAR SONY.



SONY®

SERVICE MANUAL

MODEL IDENTIFICATION (Specification Labels)

Canadian model

SONY	
FM/MW/SW	31 BAND RECEIVER MODEL NO. ICF-6800W
FREQ. RANGE :	FM 87.5-108MHz MW530-1605KHz
	SW 1.6-30MHz (29 BANDS)
DC --- 1.5V x 6	USE R20('D') STANDARD FLASHLIGHT BATT. OR EQUIV.
AC:	120V ~ 9W 60Hz
MADE IN JAPAN	

SONY	
FM/MW/SW	31 BAND RECEIVER MODEL NO. ICF-6800W
FREQ. RANGE :	FM 87.5-108MHz MW530-1605KHz
	SW 1.6-30MHz (29 BANDS)
DC --- 1.5V x 6	USE R20('D') STANDARD FLASHLIGHT BATT. OR EQUIV.
AC:	110/120/220/240V ~ 9W 50/60Hz
MADE IN JAPAN	

US model

SONY	
FM/MW/SW	31 BAND RECEIVER ICF-6800W
FREQ RANGE	FM 87.5-108MHz MW530-1605KHz
	SW 1.6-30MHz (29 BANDS)
DC	9V SIZED(R20)x6 BATT OR EQUIV
AC	110, 120, 220, 240V 50/60Hz 7W
FCC ID	AK896 ALCF-6800W
SONY	
MADE IN JAPAN	

1-1. MOS IC (IC2) HANDLING PRECAUTIONS

Since the insulation resistance of the oxidized film of MOS IC is generally very high and the film is extremely thin, the static electric charge on clothing or the body will cause the insulation to breakdown.

Observe the following precautions when replacing this IC.

1. Maintain all the pins at the same potential by wrapping the IC in aluminum foil or other similar material (See Fig. 1).

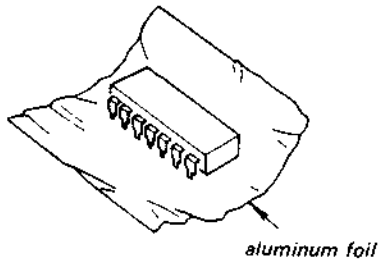

Fig. 1.

2. Ground the work bench for static electricity (See Fig. 2) (Place a sheet of aluminum onto the bench.)

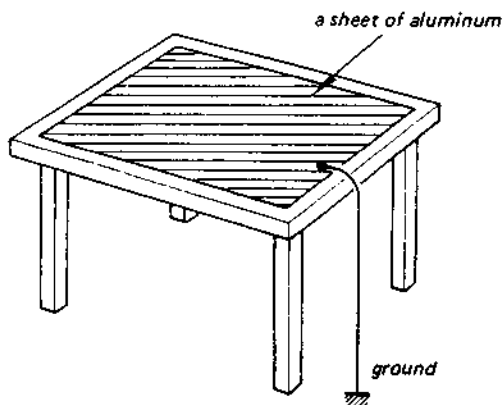

Fig. 2.

3. If it is necessary to touch the MOS IC direct, grasp the IC at a point other than the pins. Moreover, wear cotton gloves or a cotton finger sack. (Gloves made of nylon or other similar material are not recommended. The static electricity on your body can be easily discharged by wrapping a ground wire around your wrist.)

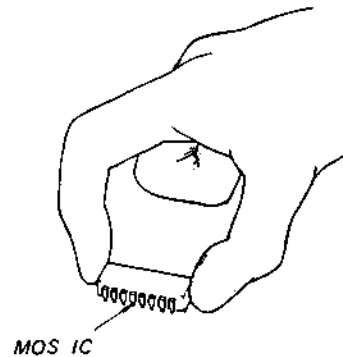

Fig. 3.

4. Short all the pins of the IC before beginning any work. Also ground the soldering iron.

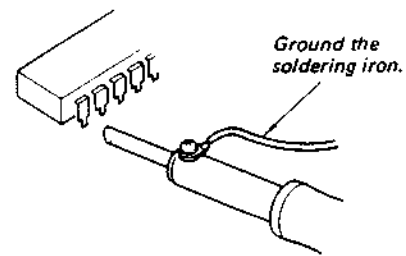

Fig. 4.

For Service Manuals Contact
MAURITRON TECHNICAL SERVICES
8 Cherry Tree Rd, Chinnor
Oxon OX9 4QY
Tel: 01844-351694 Fax: 01844-352554
Email: enquiries@mauritron.co.uk

SECTION 1 OUTLINE

1-1. CIRCUIT DESCRIPTION

This receiver has a high degree of stability which is achieved by replacing the first local oscillator of the shortwave double-super heterodyne circuitry with a PLL synthesizer.

The following is a brief circuit description.

1) Fig. 5 is a block diagram showing the principle of the PLL circuit employed in this set. Let us consider this block diagram.

Say a 1 MHz signal comes into the receiver from the antenna. In order to convert this signal to the first intermediate frequency [19.055 MHz (1st intermediate frequency of the receiver)], the frequency of VCO1 has to be 20.055 MHz. At this time, the frequency of VCO2 is set at 29 MHz.

When these two signals are fed to the mixer 1, an 8.945 MHz signal [$29 - 20.055 = 8.945$ MHz] is produced at the output of the mixer 1. This signal is now fed to the mixer 2. Meanwhile, a 10 MHz signal from a fixed oscillator is also fed to the mixer 2.

When the two signals are mixed by the mixer 2, a 1.055 MHz signal ($10 - 8.945 = 1.055$ MHz) is produced as the output of the mixer 2, and is then fed to the phase comparator. Meanwhile, a separate signal from an oscillator is also fed to the phase comparator as shown in Fig. 5 [Hereinafter, this oscillator will be referred to as the VFO.]

This phase comparator compares the phase difference of the output signal of the mixer 2 and VFO. If there is a phase difference between these two signals, this difference is produced at the output as a DC voltage and applied to the varicap (variable capacitance diode) of VCO1 to regulate the oscillating frequency of VCO1. At this time, as long as the frequency of VFO is 1.055 MHz, VCO1 will produce a stable oscillating frequency of 20.055 MHz.

This is the basic operation of the PLL circuit.

2) How are 2 MHz, 3 MHz signals received?

Let us consider how a 2 MHz signal is received. The frequencies of each of the circuits will now be as follows.

	2 MHz	(3 MHz)	(4 MHz)
VCO1	21.055 MHz	22.055 MHz	23.055 MHz
VCO2	30 MHz	31 MHz	32 MHz
VFO	1.055 MHz	1.055 MHz	1.055 MHz

By having each of the oscillators produce the frequencies listed above, 2 MHz signals can be received, but if one were to attempt to cover 1 MHz to 30 MHz in this manner, VCO2 and VCO1 would have to be similar type oscillators, which would be extremely difficult from the standpoint of production.

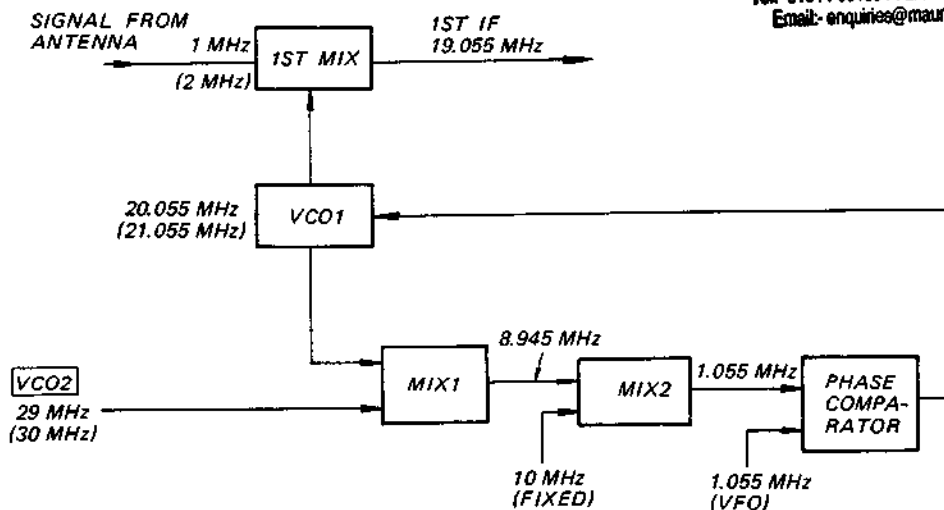

Fig. 5

For Service Manuals Contact
MAURITRON TECHNICAL SERVICES
 8 Cherry Tree Rd, Chinnor
 Oxon OX9 4QY
 Tel: 01844-351694 Fax: 01844-352554
 Email: enquiries@mauritron.co.uk

3) VCO2 of ICF-6800W

Accordingly, the circuitry of the ICF-6800W is put together as shown in Fig. 6, in determining the oscillating frequencies of VCO2.

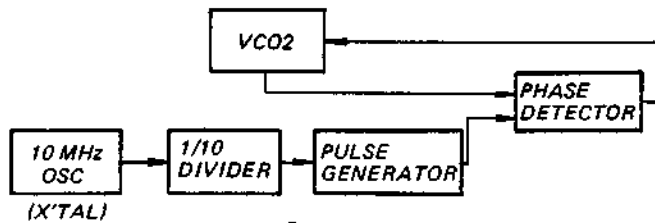

Fig. 6

(The oscillating frequencies of VCO2 are generated in increments of 1 MHz between 28 MHz and 37 MHz. Further explanations on these oscillations will be provided later on.)

a. VCO2 determines stability of PLL

With a PLL circuitry as shown in Fig. 5, it is the stability of the three oscillators, VCO2, the 10 MHz fixed oscillator, and the VFO, that determine the overall stability of the PLL. By using a crystal oscillator for the 10 MHz fixed oscillator, ample stability can be obtained. As for the VFO, since its oscillator frequency is not so very high, stable oscillation can be obtained even with an L-C oscillator. Therefore, VCO2 determines the ultimate stability of the PLL.

Fig. 6 shows a block diagram of the circuitry of VCO2. By forming another PLL to stabilize VCO2 oscillate as stable as VCO1.

b. Functions of VCO2 (refer to Fig. 6)

10 MHz is divided to 1/10 by means of a dividing circuit, to generate 1 MHz pulse signals. Next these pulse signals are made into integral-fold pulse signals of 1 MHz by means of a pulse generator.

A pulse generator is a circuit that generates integral pulses of the input signals when this happens, pulses of $(n \times 1 \text{ MHz})$ (n are integral numbers of 1, 2, 3, and so on) are generated. These pulse signals are now fed to the phase detector. Meanwhile, the signal from VCO2 is also fed to the phase detector, and the phases of these two signals are compared, with any difference being produced as a DC voltage. This voltage is fed to the variable capacitance diode of VCO2, to enable it to generate stable oscillations per every 1 MHz (28, 29 and so on up to 37 MHz).

4) Frequencies of each section of receiver

Next, each of the frequencies of the different sections of the receiver have to be changed in accordance with the frequency of the signal being received. However, from the standpoint of the makeup of the circuitry, it is difficult to change VCO2 in the same manner as VCO1. Accordingly, these changes are accomplished in the following manner.

a. Functions of controls

When the 10 MHz-step selector control for SW BAND SELECTOR is turned, the oscillating frequency of VCO1 is also switched in steps of 10 MHz.

When the 1 MHz-step selector control for SW BAND SELECTOR is turned:

1. The oscillating frequency of VCO1 is also switched in steps of 1 MHz (0-9 MHz);
 2. The oscillating frequency of VCO2 is also switched in steps of 1 MHz (28-37 MHz);
- When the MW/SW TUNING DIAL is turned: The VFO frequency changes.

In this manner, the frequencies of each of the sections change as the three controls referred to above are moved.

Refer to Page 10 for the relationship between the oscillating frequencies of each of the sections of the receiver.

b. Oscillating frequency ranges of each section and frequencies during reception

VCO1: produces oscillations from 18.975 MHz to 49.075 MHz dividing this spectrum into three bands.

VCO2: produces oscillations from 28 MHz to 37 MHz in steps of 1 MHz (28, 29, 30, 31, 32, 33, 34, 35, 36 and 37 MHz).

VFO: produces oscillations continuously from 0.975 MHz to 2.075 MHz.

These three oscillators enable reception from 1 MHz to 30 MHz. This is accomplished in the following manner.

Band switching is carried out per 1 MHz by changing the oscillating frequency of VCO2, while for frequencies in between, overall reception is provided by changing the oscillating frequency of the VFO.

For example, when a 7.5 MHz signal is to be tuned in, the frequencies of each of the sections becomes as follows:

$$\text{VCO1: } 19.055 \text{ MHz} + 7.5 \text{ MHz} = 26.555 \text{ MHz}$$

$$\text{VCO2: } 28 \text{ MHz} + 7 \text{ MHz} = 35 \text{ MHz}$$

$$\text{VFO: } 1.055 \text{ MHz} + 0.5 \text{ MHz} = 1.555 \text{ MHz}$$

(1 MHz units are changed by VCO2, and units less than 1 MHz are changed by the VFO.)
 In the case of a 15.5 MHz signal, the different frequencies are as follows:

- VCO1: 19.055 MHz + 15.5 MHz = 34.555 MHz
- VCO2: 28 MHz + 5 MHz = 33 MHz
- VFO: 1.055 MHz + 0.5 MHz = 1.555 MHz

c. Functions of filters

Fig. 7 is essentially the block diagram shown in Fig. 5 to which the frequencies of each of the sections are indicated when receiving 1 MHz, 10 MHz, and 20 MHz signals.

When receiving a 10 MHz signal, the output of mixer 2 becomes 8.945 MHz and is then fed to the phase comparator.

However, the oscillating frequencies of the VFO range from 0.975 MHz to 2.075 MHz; it is not capable of oscillating as high as 8.945 MHz. This would make it seem impossible to receive a 10 MHz signal. However, this is not the case; a signal like this is received in the following manner.

First let us take a look at the characteristics of the mixer. This will tell us the following. When signal A which is of a certain frequency is mixed with signal B which is of a different frequency, the following signals are produced.

- Frequency of A: f_0 Frequency of B: f_1
1. $f_0 - f_1$
 2. $f_0 + f_1$
 3. f_0
 4. f_1

These frequencies are fed out from the output of the mixer.

The following frequencies are fed out from the output of the mixer 2 when receiving a 10 MHz signal as indicated in Fig. 7.

1. 10 MHz - 1.055 MHz = 8.945 MHz
2. 10 MHz + 1.055 MHz = 11.055 MHz
3. 10 MHz
4. 1.055 MHz

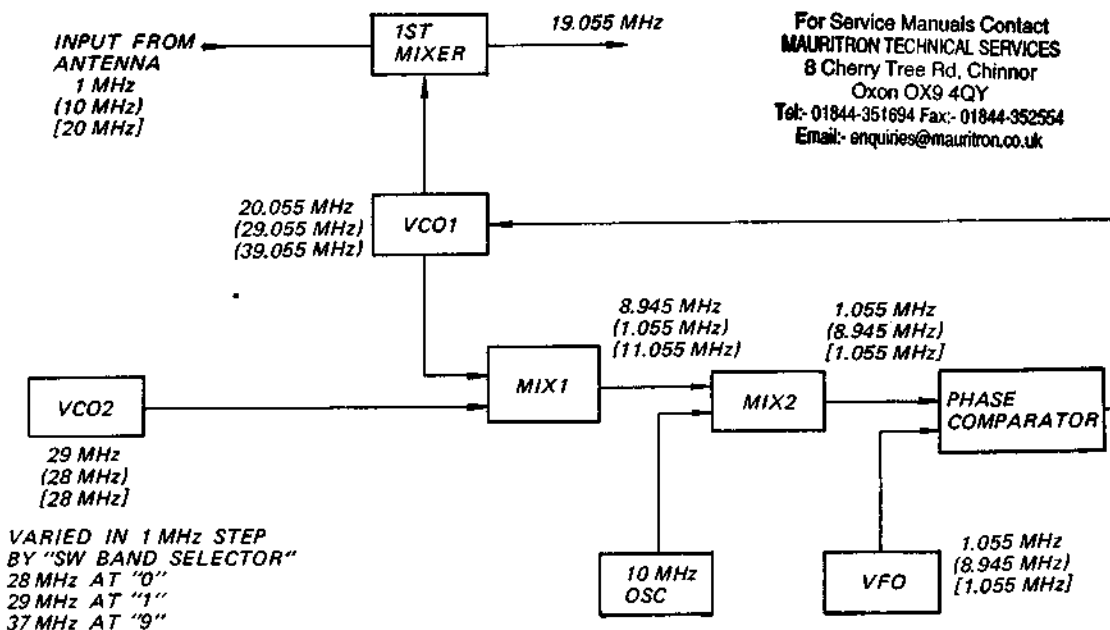

For Service Manuals Contact
 MAURITRON TECHNICAL SERVICES
 8 Cherry Tree Rd. Chinnor
 Oxon OX9 4QY
 Tel: 01844-351694 Fax: 01844-352554
 Email: enquiries@mauratron.co.uk

Fig. 7

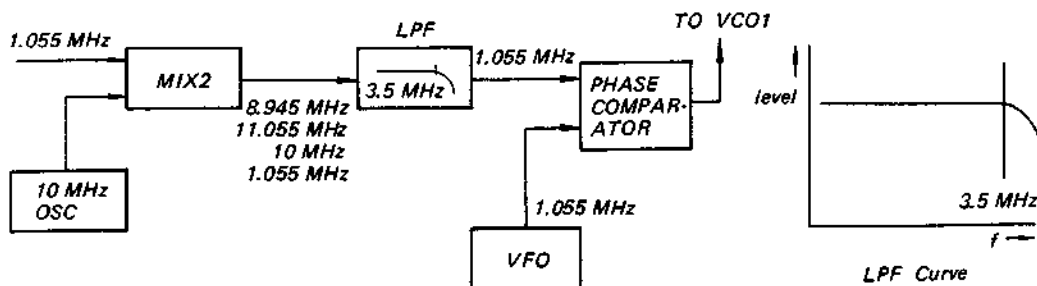

Fig. 8

Utilizing these characteristics of the mixer, a filter is fitted after the mixer 2, so that frequencies above 3.5 MHz will be filtered out (refer to Fig. 8). This means that when receiving a 10 MHz signal, only the 1.055 MHz frequency will be passed through. This signal is fed to the phase comparator and compared with the frequency of the VFO.

This then is how the reception of 10 MHz signal is carried out utilizing the filter. A filter is incorporated between the mixer 1 and the mixer 2 too, for the same purpose.

The frequency of VCO1 is controlled by first comparing the signals by the phase comparator, obtaining the difference in the form of a voltage difference, and feeding this differential to the variable capacitance diode of VCO1. As shown in Fig. 7, whether it is a 1 MHz, 10 MHz, or 20 MHz signal that is being received, the frequency that is fed to the phase comparator is always 1.055 MHz. This would make it seem that VCO1 will constantly be oscillating at the same frequency, however, the oscillator circuit of VCO1 is switched by means of a switch for 1 MHz level signals, 10 MHz level signals, and 20 MHz level signals, and so it never oscillates at the same frequency.

5) Why is it necessary to adjust the frequency range of VCO1?

As stated earlier, VCO1 is regulated by means of the voltage produced at the phase comparator. The voltage here is approximately 0.8 V to 5 V. The oscillating frequencies of VCO1 at the maximum and minimum of this voltage range becomes the frequency range of VCO1.

Fig. 9 shows the relationship between the voltage that is applied to the variable capacitance diode and capacity. Fig. 10 shows the relationship of the oscillating frequency of VCO1 when the voltage changes.

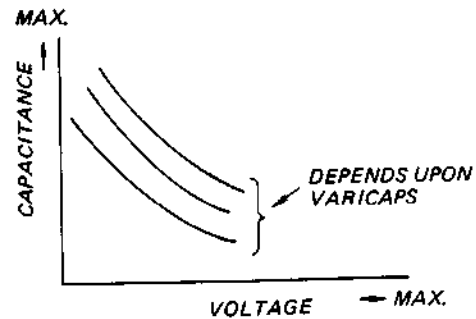

Fig. 9

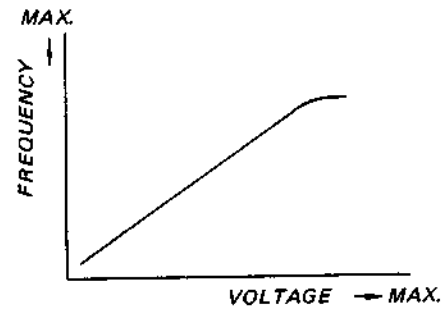

Fig. 10

The frequency when the voltage fed to the variable capacitance diode is at a minimum and the frequency when it is at a maximum are determined in the following manner.

As shown in the block diagram in Fig. 11, the frequencies that are fed to the phase comparator must satisfy the frequency range of the VFO.

The question now is how far below 0.975 MHz, and how far above 2.075 MHz are acceptable. The conclusion is that it must be within the following ranges:

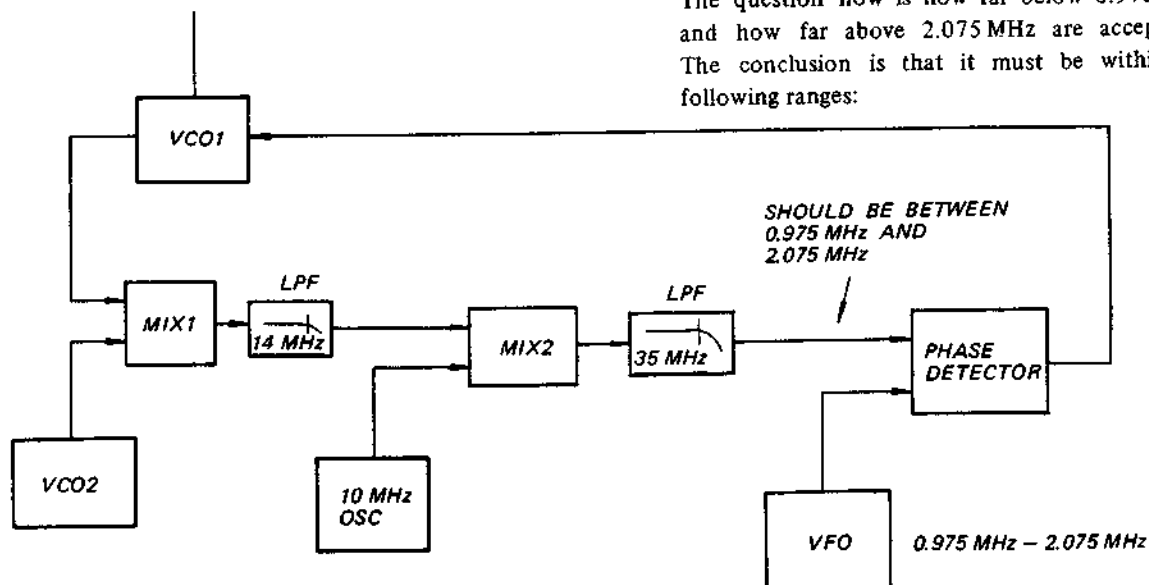

Fig. 11

- (1) Down to minus 0.975 MHz below 0.975 MHz
- (2) Below 3.5 MHz and above 2.075 MHz

Unless within the ranges of (1) and (2) above, the PLL circuitry will not function normally.

(1) is determined in the following manner.

The frequency of 0.975 MHz is an absolutely indispensable frequency because of the relationship with the VFO. Unless the frequency of VCO1 does not come down to 0.975 MHz even when the voltage to the variable capacitance diode is lowered, there will be no change in frequency when the MW/SW TUNING DIAL is turned, and so it must be below 0.975 MHz.

Concerning frequency below 0.975 MHz, in reality, there could not be a frequency of minus 0.975 MHz, but here, we shall refer to anything below zero as a minus frequency.



Fig. 12.

The frequencies that are compared in the phase comparator are neither plus nor minus but are compared in terms of absolute values, and so the frequency of minus 1 MHz will be handled as 1 MHz by the phase comparator.

Let us consider what happens when the frequency goes down below minus 0.975 MHz when the voltage of the variable capacitance diode is at its minimum.

Let us say for the sake of argument that it goes down to minus 1 MHz when the voltage of the variable capacitance diode is at its minimum.

Now if the signal that is being fed to the phase comparator is minus 0.98 MHz (the VFO frequency is 0.975 MHz), this frequency will be handled as 0.98 MHz, and so it will be judged as being higher than the VFO frequency, and a voltage in the direction of lowering the capacitance of the variable capacitance diode will be fed to the variable capacitance diode from the phase comparator.

Meanwhile, a minus 0.98 MHz signal being fed to the phase comparator means that the signal that is being fed to the mixer 2 may also be considered to be minus 0.98 MHz. The signal from VFO1 that is fed to the mixer 1, if VCO2 is producing a 28 MHz signal, will be 27.020 MHz. This is because $VCO1 - VCO2 =$ output of the mixer 2; VCO1 will be oscillating at a frequency that is 0.98 MHz lower than the frequency of

VCO2. (The word minus in minus 0.98 MHz is applied when the frequency of VCO1 is lower than that of VCO2.)

VCO1 is oscillating at 27.020 MHz. However, the voltage that is being fed to the variable capacitance diode tends to lower the oscillating frequency, and so the frequency comes down even further, going as far down as the minimum voltage being fed to the variable capacitance diode.

In this instance, the frequency will come down to minus 1 MHz because of the voltage being fed to the variable capacitance diode, and so the oscillation will continue to the frequency that has gone down to minus 1 MHz, and then stop there.

In this instance, it will come down to 27 MHz and then stop there.

In this manner, when it drops below minus 0.975 MHz, the PLL will no longer function normally.

The upper range of 2.075 MHz to 3.5 MHz is determined in the following manner. Concerning any frequency below 2.075 MHz, the situation is the same as stated earlier in that it must not go down because of the situation with the VFO.

The reason that it must not go above 3.5 MHz is that prior to being fed to the phase comparator, the signal goes through the low-pass filter.

This low-pass filter will only pass frequencies up to around 3.5 MHz, and concerning frequencies above 3.5 MHz, the signals will not be fed to the phase comparator.

This means that the phase comparator will determine that the frequency is low, and therefore feed a voltage to the variable capacitance diode that will tend to raise the frequency. Accordingly, VCO1 will now oscillate at an even higher frequency to the point where the voltage being fed to the variable capacitance diode will attain its maximum level, and there the oscillating frequency will settle.

From the foregoing, the frequency that is fed to the phase comparator will be determined as follows:

- (1) Must be below 0.975 MHz down to minus 0.975 MHz when the voltage being fed to the variable capacitance diode is at its minimum.
- (2) Must be above 2.075 MHz up to 3.5 MHz when the voltage being fed to the variable capacitance diode is at its maximum.

Refer to Page 45 for the information on adjusting the frequency range of VCO1.

6) PLL circuitry is locked by VCO2

An important factor involved in the locking of the PLL circuitry is VCO2.

If the oscillating frequency of VCO2 is not locked, the PLL circuitry cannot be locked either.

VCO2 is oscillating in increments of 1 MHz, from 28 MHz, 29 MHz up to 37 MHz, and if it is not oscillating correctly at these frequencies, the PLL circuitry will be unstable.

VCO2 applies the locking as indicated in the illustrations shown in Fig. 13 and Fig. 14 below.

When the frequency is shifted upwards from the lower end, the locking takes place as shown in Fig. 13.

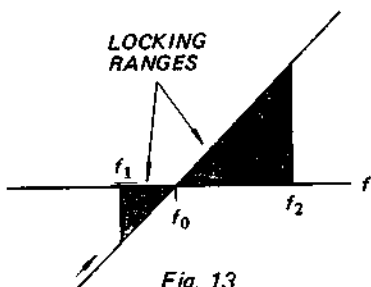

Fig. 13

When the frequency is shifted downwards from the upper end, the locking takes place as shown in Fig. 14.

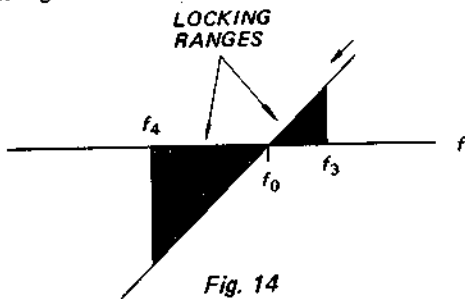

Fig. 14

The ranging of locking that takes place in this manner is referred to as the locking range or capture range.

The respective ranges are as shown below.

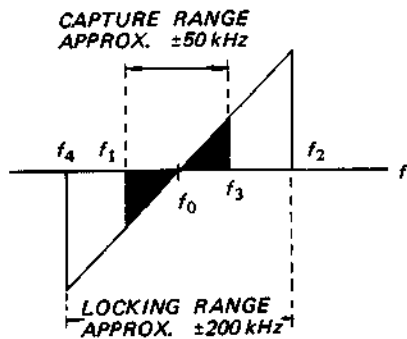

Fig. 15

The center frequency f_0 signifies the different frequencies of 28 MHz, 29 MHz up to 37 MHz which are spaced at intervals of 1 MHz. A sweep circuit is provided, and so even if there should be some shift of the frequency as shown above, as long as it is within the locking range, it will be locked at the f_0 .

(If there is no sweep circuit, then it will not lock at the f_0 unless within the capture range.)

Fig. 16 shows a block diagram of VCO2.

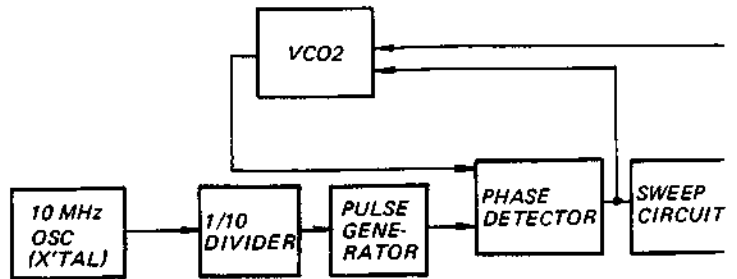

Fig. 16

Within f_1 to f_3 , VCO2 will be locked at a certain specific frequency f_0 by the output from the phase comparator circuit; however, if the oscillating frequency of VCO2 is at a frequency between f_1 and f_4 , or f_2 and f_3 , a voltage will be fed to the variable capacitance diode so that it will come within the capture range by the sweep circuit, and be locked at f_0 .

If VCO2 should be oscillating at a frequency outside either end of this locking range, the locking function will not take place.

For Service Manuals Contact
MAURITRON TECHNICAL SERVICES
 8 Cherry Tree Rd, Chinnor
 Oxon OX9 4QY
 Tel: 01844-351694 Fax: 01844-352554
 Email: enquiries@mauritron.co.uk

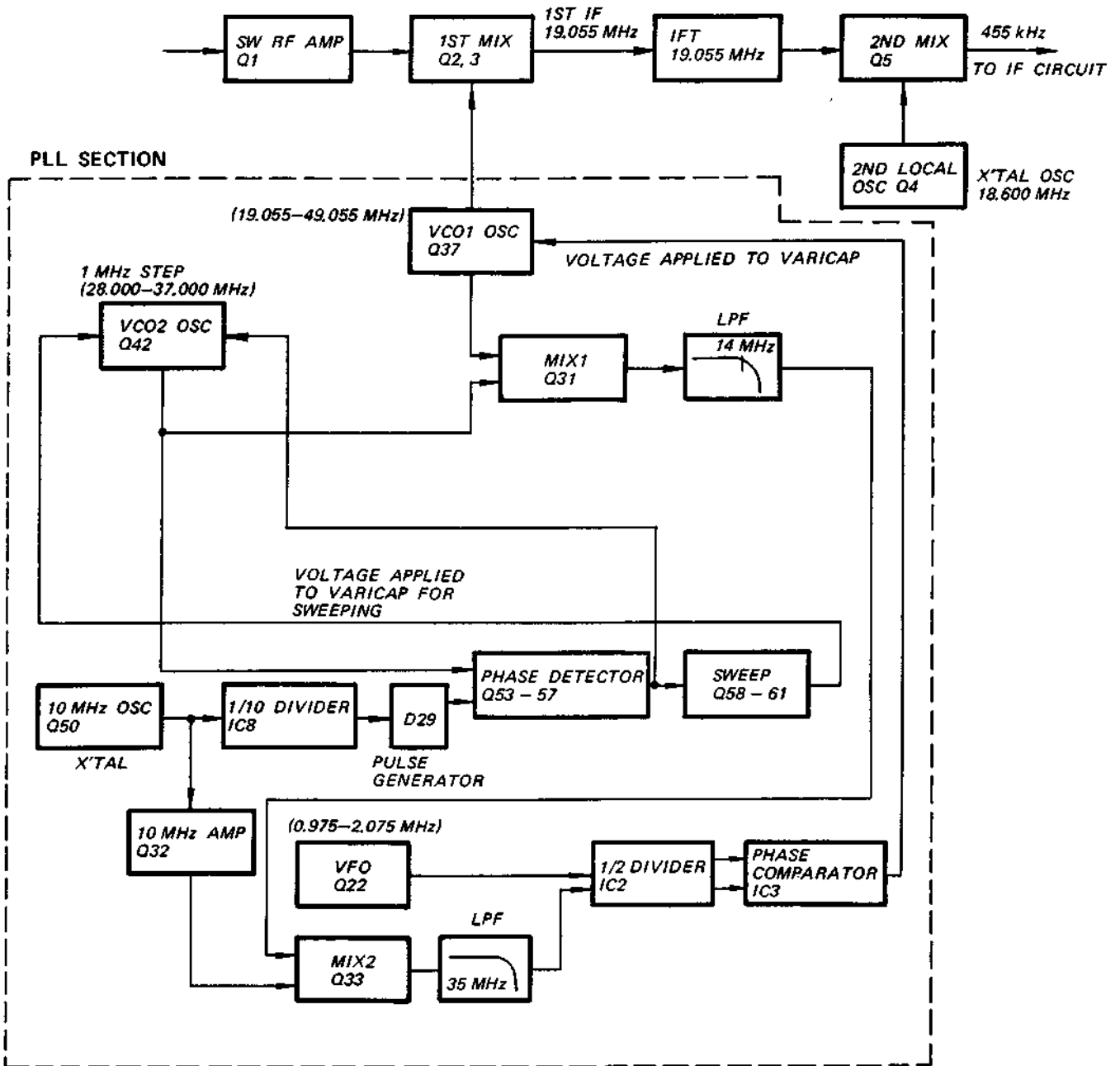

Fig. 17

For Service Manuals Contact
MAURITRON TECHNICAL SERVICES
 8 Cherry Tree Rd, Chinnor
 Oxon OX9 4QY
 Tel: 01844-351694 Fax: 01844-352554
 Email: enquiries@mauritron.co.uk

FREQUENCY RELATIONSHIP

SW BAND SELECTOR		VCO1 FREQ.	VCO2 FREQ.	VFO FREQ.
10 MHz STEP (MHz)	1 MHz STEP (MHz)	(Oscillates in 1 MHz steps and repeatedly oscillates from 0 to 9).		Varied by TUNING knob.
0	0	19.055 ~ 20.055 (MHz)	28 (MHz)	1.055 - 2.055 (MHz)
	1	20.055 ~ 21.055	29	
	2	21.055 ~ 22.055	30	
	3	22.055 ~ 23.055	31	
	4	23.055 ~ 24.055	32	
	5	24.055 ~ 25.055	33	
	6	25.055 ~ 26.055	34	
	7	26.055 ~ 27.055	35	
	8	27.055 ~ 28.055	36	
	9	28.055 ~ 29.055	37	
10	0	29.055 ~ 30.055	28	
	1	30.055 ~ 31.055	29	
	2	31.055 ~ 32.055	30	
	3	32.055 ~ 33.055	31	
	4	33.055 ~ 34.055	32	
	5	34.055 ~ 35.055	33	
	6	35.055 ~ 36.055	34	
	7	36.055 ~ 37.055	35	
	8	37.055 ~ 38.055	36	
	9	38.055 ~ 39.055	37	
20	0	39.055 ~ 40.055	28	
	1	40.055 ~ 41.055	29	
	2	41.055 ~ 42.055	30	
	3	42.055 ~ 43.055	31	
	4	43.055 ~ 44.055	32	
	5	44.055 ~ 45.055	33	
	6	45.055 ~ 46.055	34	
	7	46.055 ~ 47.055	35	
	8	47.055 ~ 48.055	36	
	9	48.055 ~ 49.055	37	

(VFO actually oscillates at frequencies from 0.975 to 2.075 MHz. For example, at 1 MHz, when the frequency of the VFO is 0.975 MHz, the frequency of VCO1 will become 19.975 MHz. When the frequency of the VFO is 1.055 MHz, the dial scale will be exactly 0.)

The VFO is also used as the local oscillator for MW reception. Fig. 18 shows the relationship between readings on the scale drum in the MW and SW receptions on the one hand and the frequencies on the other.

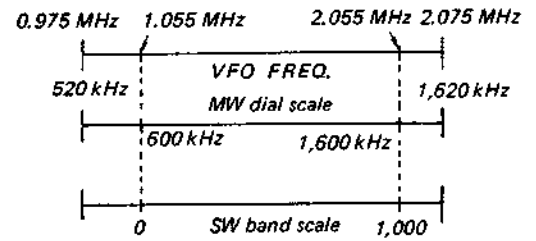

Fig. 18

IC3 (phase comparator)

As shown in Fig. 21, IC3 comprises a digital phase comparator consisting of a combination of gates and an active low-pass filter amplifier.

The digital phase comparator compares the phases of the signals that come into the terminals ⑦ and ⑧.

Phase comparison is carried out at the leading edge of the pulse. (Refer to Fig. 19)

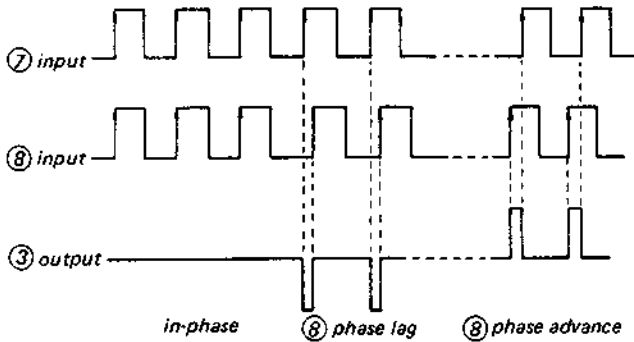

Fig. 19

As shown in Fig. 19, when the phase of input ⑧ is lagging, the output is low (0) level. When the phase of input ⑧ is advanced, it will be high (1) level.

The signals that appear at the terminal ③ after going through the phase comparator are fed to the active filter. Fig. 20 shows an approximation of this active filter.

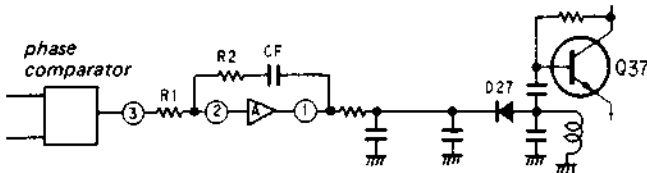

Fig. 20

Basically, the active filter is composed of R1 and CF. By applying negative feedback from the return of the CF, the linear zone is expanded at the 6 dB/oct curve formed by R1 and CF.

As for its overall functioning, if for example the frequency of VCO1 is higher than the intended one:

- A positive pulse signal will be sent out from the output of the comparator.
- The output is filtered by the active filter, while the polarity of this amplifier is also reversed, and so a DC signal that tends to become close to the ground potential is produced from the filter output.
- The reverse bias fed to D27 drops, and the equivalent capacity increases.
- Since D11 is connected as an element of the oscillator's L-C of VCO1, the oscillating frequency is lowered and locks on the desired frequency.

Relationship between voltage difference between both ends of variable capacitance diode and capacity

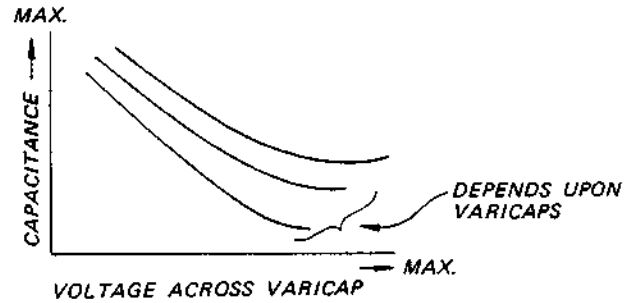

Fig. 22

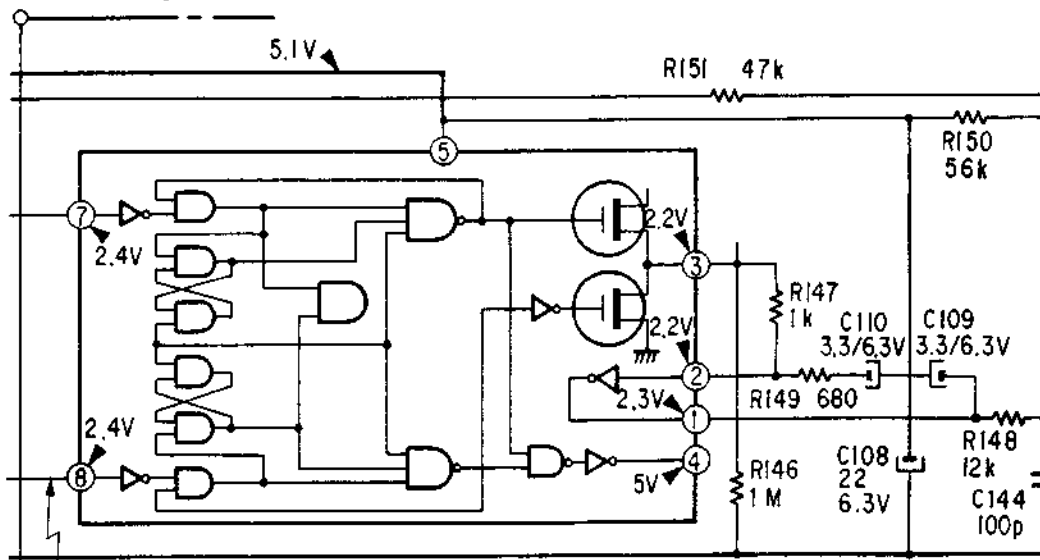

Fig. 21

5Vp-p

For Service Manuals Contact
MAURITRON TECHNICAL SERVICES
 8 Cherry Tree Rd, Chinnor
 Oxon OX9 4QY
 Tel: 01844-351694 Fax: 01844-352554
 Email: enquiries@mauritron.co.uk

Role of Q72 (manual gain control) (Refer to Fig. 23)

The antenna band-pass filter has a wide bandwidth of around 1 MHz to 30 MHz, and so both high-level and low-level signals come in together.

In the case of the situations where the frequencies of the incoming signals are very close to each other, such as in amateur radio, if there should be a station with a high-level signal in the immediate vicinity of the frequency the listener wishes to tune in to, the lower-level signal will receive interference from the high-level signal, and this could cause cross modulation.

The role of this circuit is to adjust the level of the input signal coming in from the antenna so that the high-level signal will not interfere with the low-level signal, to reduce the effects of this cross modulation.

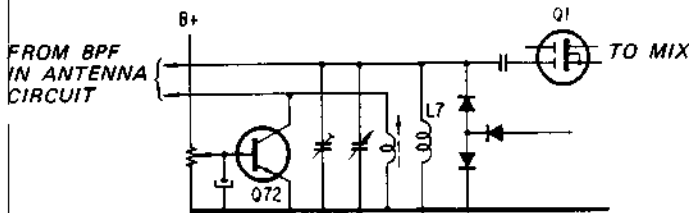

Fig. 23

IC2 (1/2 divider) (Refer to Fig. 24)

IC2 is a 1/2 divider, to demultiply the frequency of the input to 1/2.

In order to reduce the input frequency of IC3 to the order of several MHz, it goes through a 1/2 dividing process by means of IC2, and the pulse signal is then fed to the input of IC3.

A signal comprising a signal consisting of a mixture of the signals of VCO1 and VCO2 to which a 10 MHz signal has also been mixed is fed to the terminal ③.

The signal from the VFO is fed to terminal ①.

Each of the signals are converted into pulse signals divided by 2 before being fed to the input of IC3. In order to ascertain whether IC2 is defective or not, all that has to be done is to ascertain whether the signals fed to terminal ③ or ⑪ are divided by 2 when they emerge at terminal ① or ⑬.

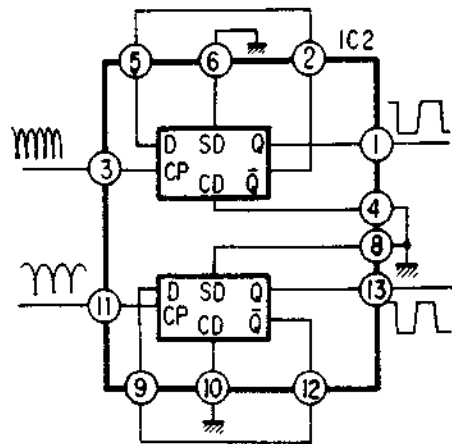

Fig. 24

When actually carrying out this work on the printed circuit board, each of the pins of IC2 should be raised from the pattern, a test circuit as shown in Fig. 25 prepared, and signals fed to it, then confirm the frequency and waveform of the output.

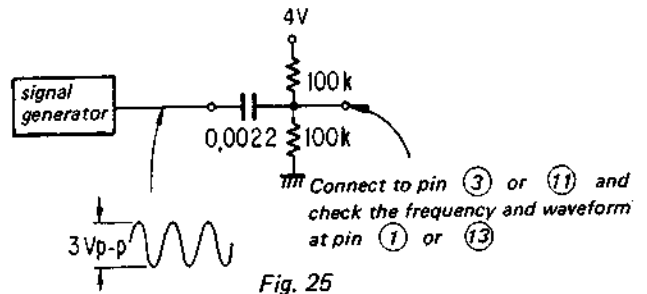

Fig. 25

Balanced-Type 1st Mixer (Q2 and Q3) (Refer to Fig. 26)

Q2 and Q3 are referred to as a balanced-type mixer, and comprise a circuit that is used to extract only the necessary IF signal.

The signal from the antenna passed through the band-pass filter, then passes through the RF amplifier, again passes through a band-pass filter, and goes to the 1st mixer.

However, if the signals that have to be eliminated by these RF filters should be excessively powerful, the RF filters will be unable to cope with them and they may reach the 1st mixer.

If these unwanted frequencies should be the same as the 1st intermediate frequency, with the single-type conventional mixers used heretofore, they would go right through the mixer into the 1st IF amplifier circuit.

If that should happen, since it will not be possible to eliminate these unwanted signals in the circuits that follow the 1st IF amplifier, they will necessarily remain in the form of interference.

However, in the case of a balanced-type mixer, the input signal that comes in from the balanced end does not itself emerge at the output end; only the converted frequencies emerge.

The ICF-6800W uses a balanced-type mixer like this, to balance the input signal end and eliminate the aforementioned interference.

Let us say that a signal that is the same frequency as the 19.055 MHz 1st intermediate frequency comes into the input of the mixer in the schematic shown in Fig. 26. This signal will enter the Q2 and Q3 gates in the same phase, and will appear at the drains also in phase. They will then be fed to each end of the IFT A1, and so will cancel out each other.

Meanwhile, the local-oscillator signal is fed to the source sides of Q2 and Q3 in opposite phase, and so the signal that goes through a frequency-conversion process by means of the local oscillator signal fed to the source side appears at the drain in opposite phase in the additive form.

Therefore, IFT A1 is fed only with the output of the converter circuit, and so it is possible to obtain an IF signal that is stronger than that which can be obtained with a single-conversion type mixer.

VT2 is provided for adjustment purposes to match the gain figures of Q2 and Q3, and to enable even more complete cancellation.

Note: The local oscillation components are also generated in IFT A1, but they can be eliminated readily by means of the filter effect.

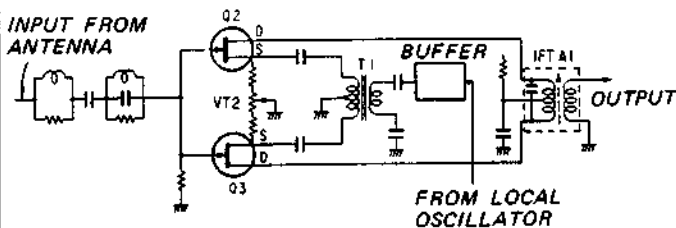

Fig. 26

**Functions of Q53-Q57 (phase detector)
(Refer to Fig. 27)**

This circuit is provided in order to maintain the oscillating frequency of VCO2 at a constant figure. In other words, locks it at each point, whether it is 28 MHz, 29 MHz and so on up to 37 MHz, so that frequency will not drift. It functions as follows.

Basically, it mixes the signal from VCO2 that is being fed to the gate with the pulse signal that is being fed to the source, and extracts the differential (AC component) to regulate VCO2.

Q53 comprises a balanced-type mixer. Signals that are fed to each of the gates of Q53 in the same

phase also are produced at the drain in the same phase, and so only the DC components are produced at the output of the differential amplifier Q55 through Q57.

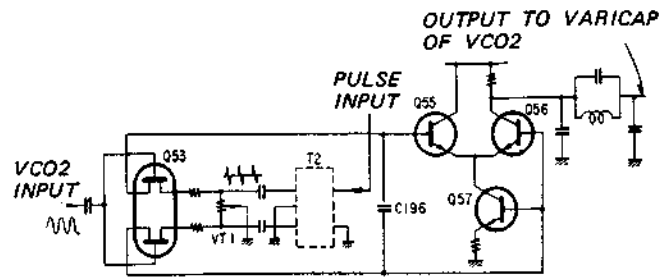

Fig. 27

The pulse signals that are being fed to the sources are each being fed in opposite phase, and so the signals that have gone through the frequency conversion process are fed to the differential amplifier each in opposite phase, so that amplified AC components are produced at the output of the differential amplifier.

Let us say, for example, that the frequency of VCO2 is 30.00 MHz.

As shown in Fig. 28, the pulse signals that are added at the source include pulse signals that are intergral 1 MHz. These pulse signals are generated by means of a pulse generator.

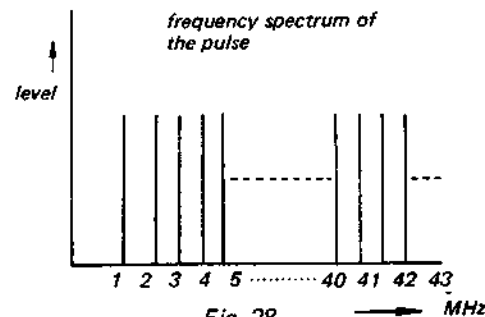

Fig. 28

A beat signal is generated between the frequency of VCO2 (30.001 MHz) and the pulse signal (30 MHz). (In other words, a 0.001 MHz beat signal.)

This beat signal is fed to the differential amplifier, each in opposite phase, and then derived as the output. At this time, the harmonic components are eliminated by the filter circuit.

This AC-component output is fed to the variable capacitance diode of VCO2 to vary the oscillating frequency of VCO2.

If the frequency of VCO2 is 30 MHz, then a zero beat is generated, and so there will be no AC components at the output; only the DC components.

In this manner, the oscillating frequency is varied by varying the capacitance of the variable-capacitance diode by the AC components. However, if the response speed of this loop is faster than the variations of the AC components, then the locking will take place instantaneously.

Through these means, variations in frequency are kept within the accuracy of the crystal for the 1 MHz pulse generation.

VT1 is provided for making adjustments so that the functioning of each of the FETs of Q53 is equalized.

Functions of Q58–Q61 (sweep circuit) (Refer to Fig. 29)

The sweep circuit is provided to carry out a locking function so that the oscillations of VCO2 do not drift when the SW BAND SELECTOR control is turned and the oscillating frequency of VCO2 does not get into the capture range and is unlocked. If it unlocks from a locked condition because of temperature variations, then this would be an instance of it getting beyond the locking range, and the sweep circuit would not be of any use at all.

When VCO2 is in a locked condition, a signal is not fed to Q58, and so this sweep circuit does not function.

The frequency at which VCO2 is locked has a width of several hundred kHz plus or minus the intended frequency; when within this range, it is pulled into the intended frequency much like an AFC circuit.

When not in this range, the lock is released, and the PLL circuitry is no longer capable of stable reception of the receiver.

Suppose that the lock is released. Now a beat component is fed to the base of Q58, as explained in the section on the phase detector.

The signal amplified by the AC amplifier Q58 is rectified by D31 and fed to Q59. This serves to make Q59 ON.

When Q59 goes ON, C203 will now be grounded, and this will disconnect AC-wise the negative feedback circuit of R221.

The signal from the collector of Q61 that has passed through R224 and C204 is fed back to the base of Q60 through a positive feedback circuit, and because the negative feedback circuit is cut out, Q60 and Q61 start oscillating at low frequencies.

The output of these oscillations is extracted and fed to the variable-capacitance diode of VCO2, to slowly change the capacitance of the variable capacitance diode.

When the frequency of VCO2 is moved up to the width of its locking range by this sweep circuit, it will try to lock in a certain frequency.

When VCO2 locks in, there will no longer be a beat component at Q58, and so Q59 goes OFF, and the oscillations of Q60 and Q61 will stop.

The sweep circuit functions in this manner so that VCO2 will lock quickly in a certain frequency.

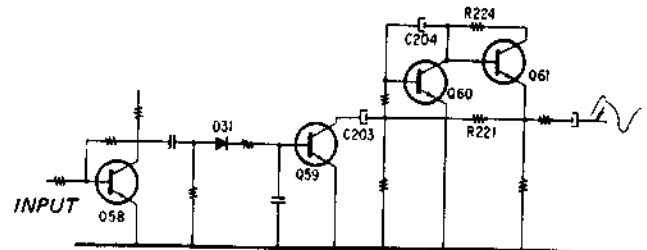

Fig. 29

Q48 and Q49 (display switch) (Refer to Fig. 30)

The ICF-6800W is equipped with a counter that provides a digital readout of the frequency being tuned to. This part of the receiver has a high current drain (approximately 100 mA), and so it is equipped with a display switch to enable it to be switched off when it is not needed. Fig. 30 is a schematic of the display-switch circuit.

Q48 and Q49 constitute a bistable multivibrator; when the power switch is ON, Q49 will be OFF and Q48 will be ON. (In an inactive state, because of R196, Q49 goes OFF.)

When Q48 is OFF, a high voltage is fed to the base of Q47, and so it goes ON.

When Q47 goes ON, it lowers the base potential of Q46, and so Q46 also goes ON, and a B+ voltage is supplied to the counter section. Q46 is a PNP transistor, and it goes ON when its base potential drops in more than 0.6 V below the emitter.

When S7 is switched ON, the positive end of C255 is grounded so the potential at point (A) drops quickly. This amounts to the same thing as feeding in a negative pulse signal.

When in an inoperative state, C179 and C180 are maintained at the potentials shown in Fig. 30.

When a negative-pulse signal is applied, it passes through C179 to the base of Q48, and Q48 turns OFF. There is no voltage difference between the two ends of C180, and so the negative-pulse signal will not pass through it, while the pulse signal is applied to Q49 after passing through R198, and so it becomes an extremely small pulse.

When Q48 goes OFF, the collector potential of Q48 goes up, to feed a charging current to C180. Q49 goes ON by this current flow. When Q49 goes ON, Q48 goes OFF.

When Q49 goes ON, the collector voltage of Q49 becomes close to zero volts, and so Q47 also goes OFF. When Q47 goes OFF, the potential of the base of Q46 rises, and Q46 also goes OFF. As a result, the supply of the B+ voltage to the counter section stops.

When S7 is pressed, these functions are repeated by Q48 and Q49 alternately. When S7 is pressed again, Q48 and Q49 revert to their original state, and Q46 goes ON.

In this manner, each time S7 is pressed, Q46 repeats going ON and OFF.

Function of R196

This resistor determines the bias of the base Q48, in order that Q48 will go OFF without fail after the RADIO switch has been switched ON.

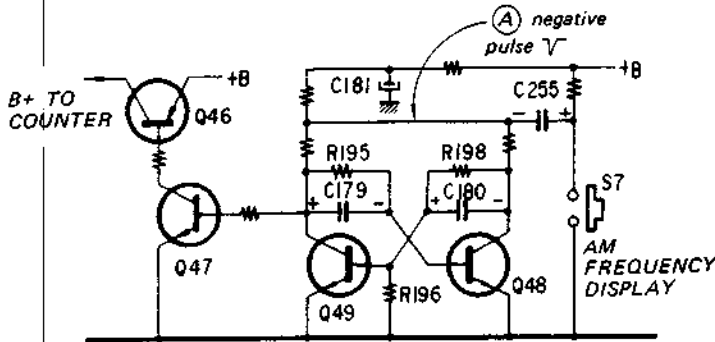

Fig. 30

Frequency Counter

The frequency counter of the ICF-6800W provides a digital readout of the frequency being tuned in. Fig. 31 shows a block diagram of its circuitry. Digital readouts are provided only during reception of MW and SW bands.

During MW reception, the frequency of the VFO, and during SW reception the oscillating frequency of VCO1, are counted respectively.

Q25 and Q26 go ON during MW reception and SW reception respectively, and provide frequency readouts of either MW or SW.

The functions of each of the circuits will now be explained.

IC7 (RF amplifier)

Provided to amplify the signals from the VFO or VCO1 for feeding to the next stage, and has a bandwidth ranging from several hundred kHz to several score MHz.

IC6 (divider)

The signal that has passed through IC7 is divided by 40 in IC6.

This is because unless the input signal of IC4 is demultiplied by 1/40, the frequency countout will not be accomplished properly.

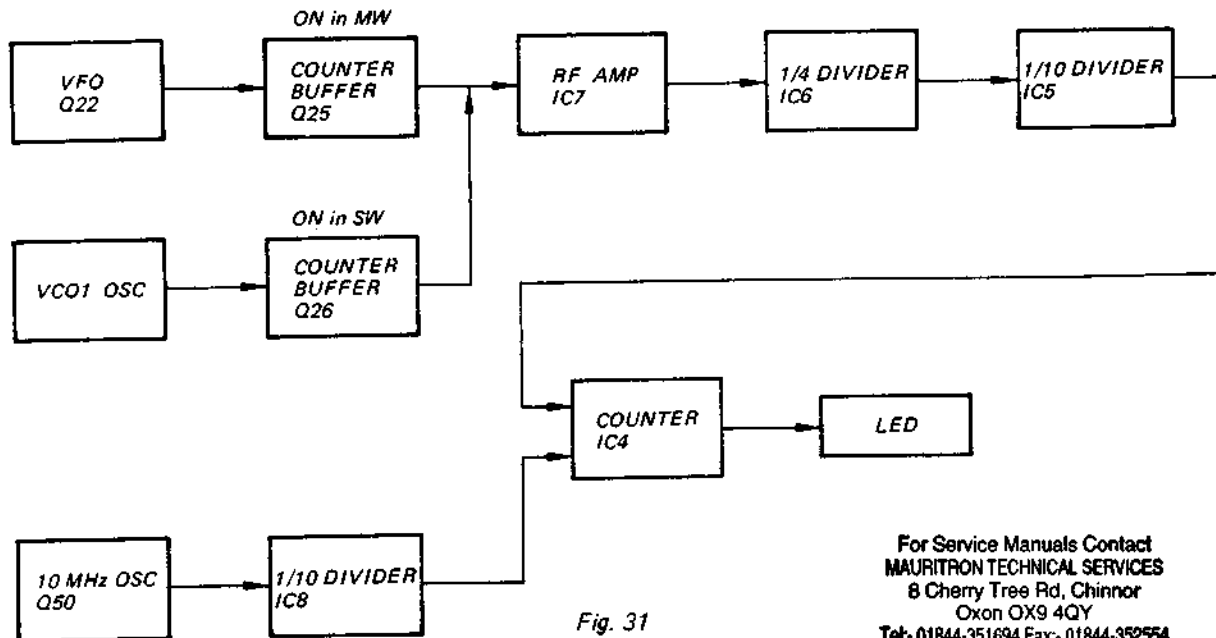

Fig. 31

For Service Manuals Contact
MAURITRON TECHNICAL SERVICES
 8 Cherry Tree Rd, Chinnor
 Oxon OX9 4QY
 Tel: 01844-351694 Fax: 01844-352554
 Email: enquiries@mauritron.co.uk

IC8 (divider)

This divider is provided to divide the 10 MHz generated by Q50 to 1 MHz; it is a 1/10 divider.

Q50 is a crystal oscillator, and so it provides extremely stable oscillation. It is used to formulate the control and gate signals for the counter.

IC4 (Counter)

Basic Operation of IC4 Counter (Refer to Fig. 32)

When a signal whose frequency is to be measured is applied to terminal 1, this signal enters the gate circuit. A reference frequency of 1 MHz is applied to terminal 7, and this signal is applied to the control-signal generator through the divider. This signal is further divided in the control-signal generator so that a pulse lasts for a second as shown in Fig. 33-b. Actually, a display down to 1 kHz in AM and 100 kHz in FM is sufficient. Thus, pulses in AM and in FM are set to be 320

msec and 0.8 msec respectively. This signal from the control-signal generator is applied to the gate circuit. This signal is referred to as the gate signal. The gate circuit acts as an AND circuit, and an output signal appears when both (a) and (b) are at the same level. This output signal is divided and counted by the decimal counter.

As shown in Fig. 33, 6 pulses counted for a duration of 1 second make up the frequency 6 Hz.

Actually, high frequencies on the order of several score MHz are received. Since the gate signal lasts for a second, the decimal counter must count pulses on the order of 10^5 . Therefore, an extremely high-speed counter is essential. The gate signal and the frequency to be measured are divided in the same proportion and counted. This method is called "Prescaling".

For Service Manuals Contact
MAURITRON TECHNICAL SERVICES
 8 Cherry Tree Rd, Chinnor
 Oxon OX9 4QY
 Tel: 01844-351694 Fax: 01844-352554
 Email: enquiries@mauritron.co.uk

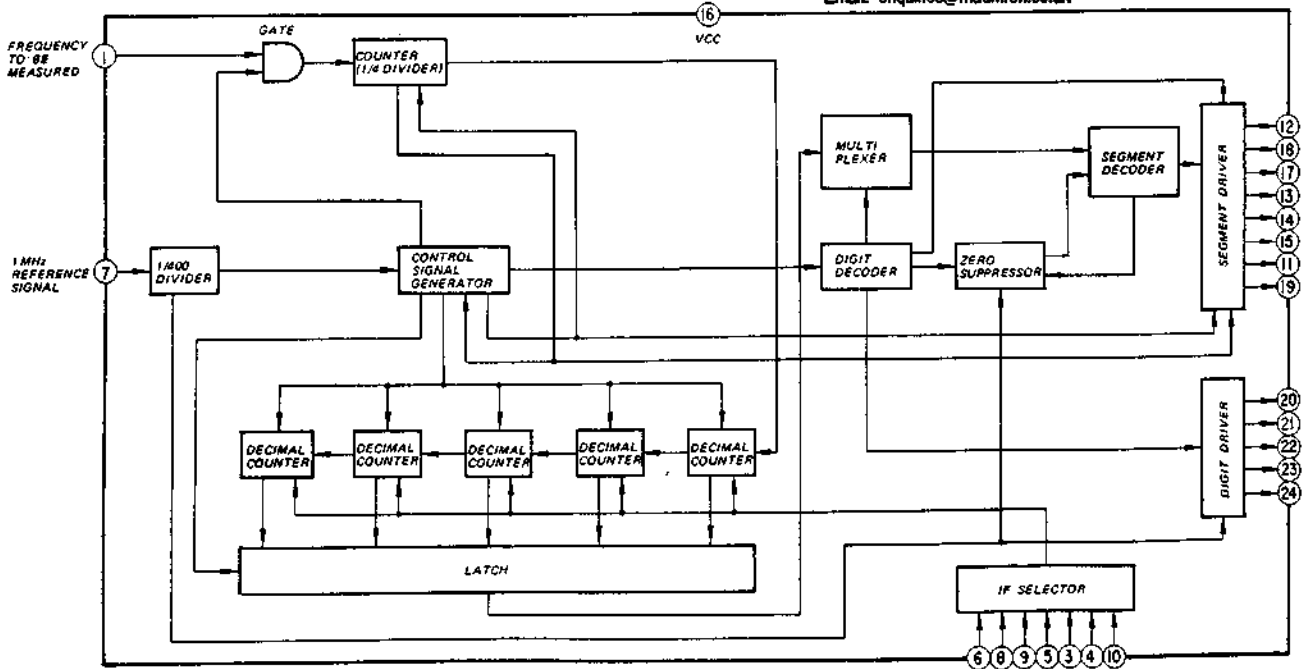

Fig. 32

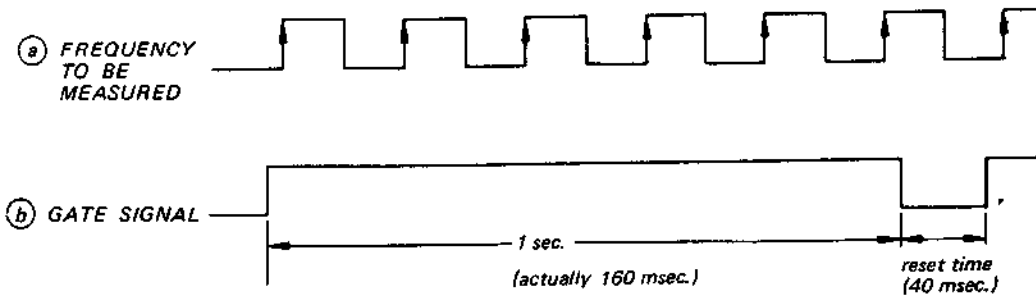

Fig. 33.

Decimal Counter

The signal generated above is applied to the decimal counter and its frequency is counted. The decimal counter returns to 0 after counting from 0 to 9, and "1" of 10 is displayed on the next LED.

Below, an explanation of the operation of the decimal counter will be given using an example of a decimal counter on the Master-Slave system (negative going trigger).

In this method as shown in Fig. 34 the counter reads the signal while the input signal is at a higher level, as indicated by the heavy line, and generates signals according to the truth value table in Fig. 35 when the input signal changes from the high to the low level as indicated by the arrow.

The signal to be measured is applied to input A. Output D is connected to input A of the next counter, and the next counter displays 1 when the count changes from 9 to 10.

Output D becomes 1 at 8 of the truth value table, but the next counter does not display 1. The reason for this is that the signal to input A of the next counter is at a high level for both 8 and 9 and only goes low when the signal changes to a low level after 9.

At this instance, the input A of the next counter becomes 1 and the tenth display displays "1".

The frequency is measured by using this technique.

The signals (outputs from A, B, C, D mentioned above) from the decimal counters are sent to the latch circuit immediately after the counting.

When the gate turns on and off once and the counting goes off, all the decimal counters are reset to 0 for the next counting.



Fig. 34.

For Service Manuals Contact
MAURITRON TECHNICAL SERVICES
 8 Cherry Tree Rd, Chinnor
 Oxon OX9 4QY
 Tel: 01844-351694 Fax: 01844-352554
 Email: enquiries@mauritron.co.uk

TRUTH VALUE TABLE

	D	C	B	A
0	0	0	0	0
1	0	0	0	1
2	0	0	1	0
3	0	0	1	1
4	0	1	0	0
5	0	1	0	1
6	0	1	1	0
7	0	1	1	1
8	1	0	0	0
9	1	0	0	1

reset

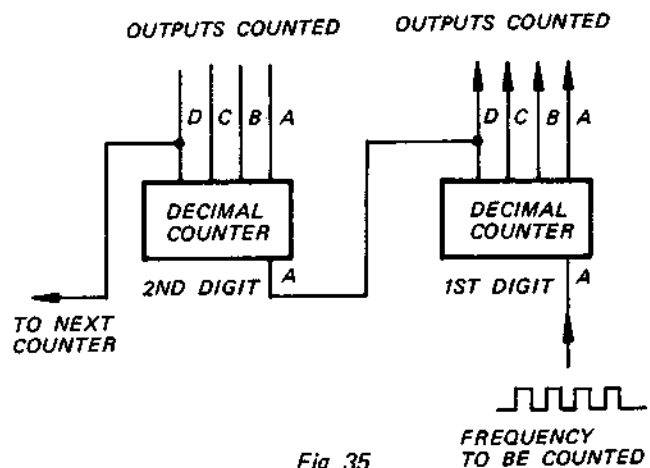

Fig. 35

Latch Circuit (Refer to Fig. 36)

The result of the decimal count is put in the memory of the latch circuit when the gate signal is terminated. The purpose of the latch circuit is to hold certain information for a certain period of time.

In general, the latch circuit is made up of D type flip-flops.

Without the latch circuit, the display of the counter changes successively from 0 to 9 as the counter counts pulses while the gate is open. The display becomes held and readable only when the gate is closed. The display returns to 0 when a reset signal is received and starts counting the pulses again as the gate opens. This operation is repeated without stopping.

Therefore, with the latch circuit the display is held when the counting is over and continues to be so even when the reset signal is received. The display changes to show the results of the next count only when the next count is finished.

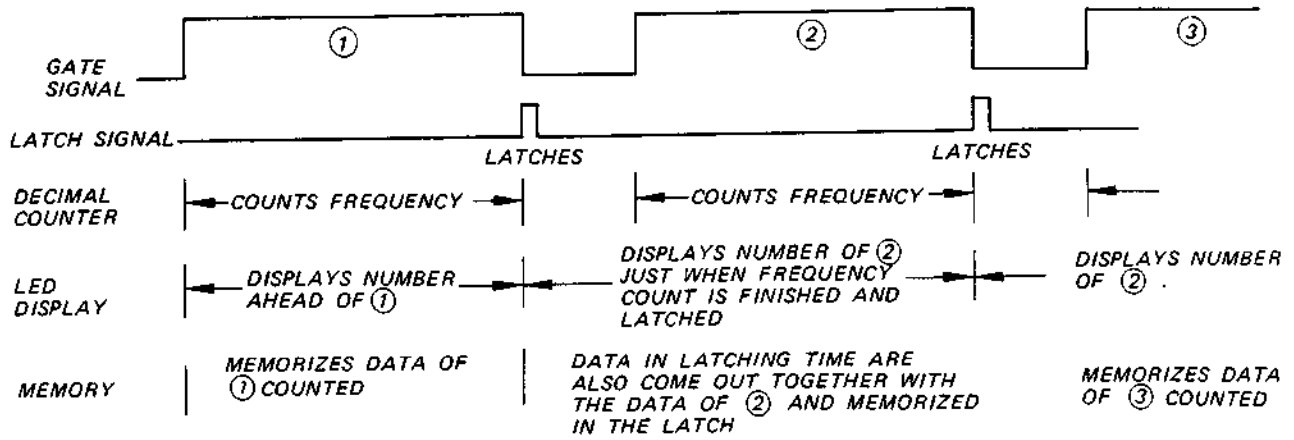

Fig. 36

Multiplexer (Refer to Fig. 37)

The signal from the latch circuit is then sent to the multiplexer. This IC controls the LED display unit by a method called "Dynamic Drive", the generation of pulses to illuminate the digits of the LED in order from the 1st to the 5th digit.

Each digit of the LED is lit in sequence at a fast rate, but appears to the human eyes to be lit continuously due to the "persistence of vision" effect.

This operation is performed through the multiplexer.

For Service Manuals Contact
MAURITRON TECHNICAL SERVICES
 8 Cherry Tree Rd, Chinnor
 Oxon OX9 4QY
 Tel: 01844-351694 Fax: 01844-352554
 Email: enquiries@mauritron.co.uk

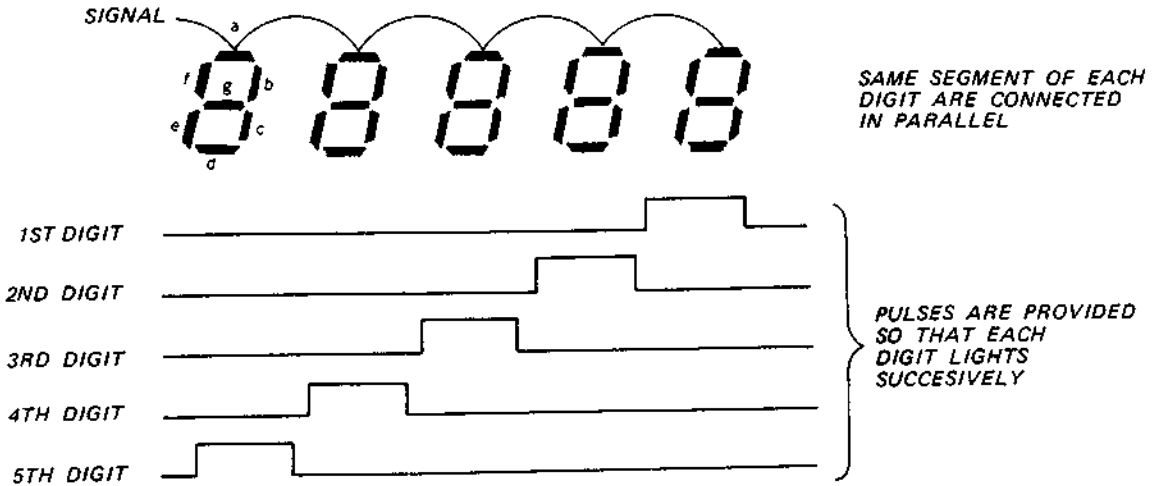
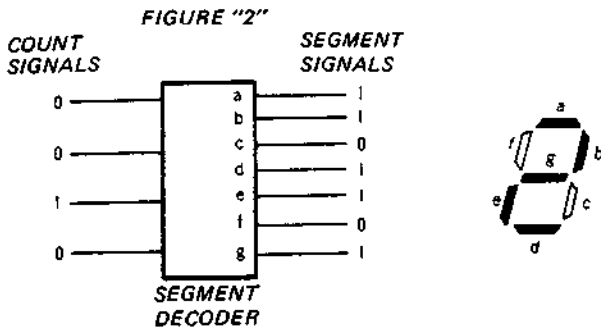

Fig. 37

Segment Decoder

The purpose of the segment decoder is to change the output signals of the decimal counter to the signals that illuminate the corresponding segment (a-g) of the LED.

The segment decoder operates as shown below. When the figure "2" is displayed, for example, the signals shown in Fig. 38 are sent as the output signals from the segment decoder.



DISPLAY	COUNT SIGNAL	SEGMENT SIGNALS						
		a	b	c	d	e	f	g
0	0 0 0 0	1	1	1	1	1	1	0
1	0 0 0 1	0	1	1	0	0	0	0
2	0 0 1 0	1	1	0	1	1	0	1
3	0 0 1 1	1	1	1	1	0	0	1
4	0 1 0 0	0	1	1	0	0	1	1
5	0 1 0 1	1	0	1	1	0	1	1
6	0 1 1 0	1	0	1	1	1	1	1
7	0 1 1 1	1	1	1	0	0	1	0
8	1 0 0 0	1	1	1	1	1	1	1
9	1 0 0 1	1	1	1	1	0	1	1

Fig. 38

Segment Driver

This amplifies signals generated by the segment decoder to the level which required to operate the LED segments.

Digit Decoder

This generates signals for the multiplexer and the digit driver simultaneously.

Digit Driver

As previously mentioned in the explanation of the multiplexer, this IC provides the "Dynamic Drive" for the LED display. This illuminates the 1st to the 5th digits in order. Q62-Q66 control the on-off operations of each digit's LED. The on-off signals are sent to Q62-Q66 by the digit driver.

Fig. 39 shows an example of the timing of the outputs for displaying 1, 2, 3, 4 or 5. These waveforms are shown in ideal form. Actual waveforms are much distorted. The outputs are put out when both the digit and segment outputs are in high level.

Zero Suppress

Zero suppress is the circuit which disables display of zeroes preceding the significant figure, as shown below.

example: 00 100 kHz

These 0 figures are not displayed.

IF Selector

Since the frequency of the VCO1 is 29.055 MHz, the counter would indicate 29.055 MHz if counted as it is, even if one wishes to display 10 MHz when receiving SW.

In order to get a display of 10 MHz, 10 MHz must first be subtracted from the VCO1 frequency. The I-F selector performs this subtraction. The counter has a display of five digits. If 00000 is set to be displayed when 19055 is applied, 00001 kHz is displayed when 19.056 MHz is measured.

In order to get this performance, a signal from which 19056 is subtracted should be applied when resetting the decimal counter for the next count.

These figures are calculated as follows.

$$\frac{100000}{6 \text{ units}} - 19055 = 80945$$

The figure 80945 should be set in the counter before counting a given frequency.

When 19055 is counted, the display of the counters becomes 0, since 19055 + 80945 = 100000.

1 in the sixth digit is not displayed, since only 5 figures are displayed.

The IF selector selects the figures to set in the counter before counting. The following figures are set by the IF selector in this system.

- FM 89200
- MW 99545
- SW 80945 (WIDE, NARROW)
- 80943 (USB)
- 80947 (LSB)

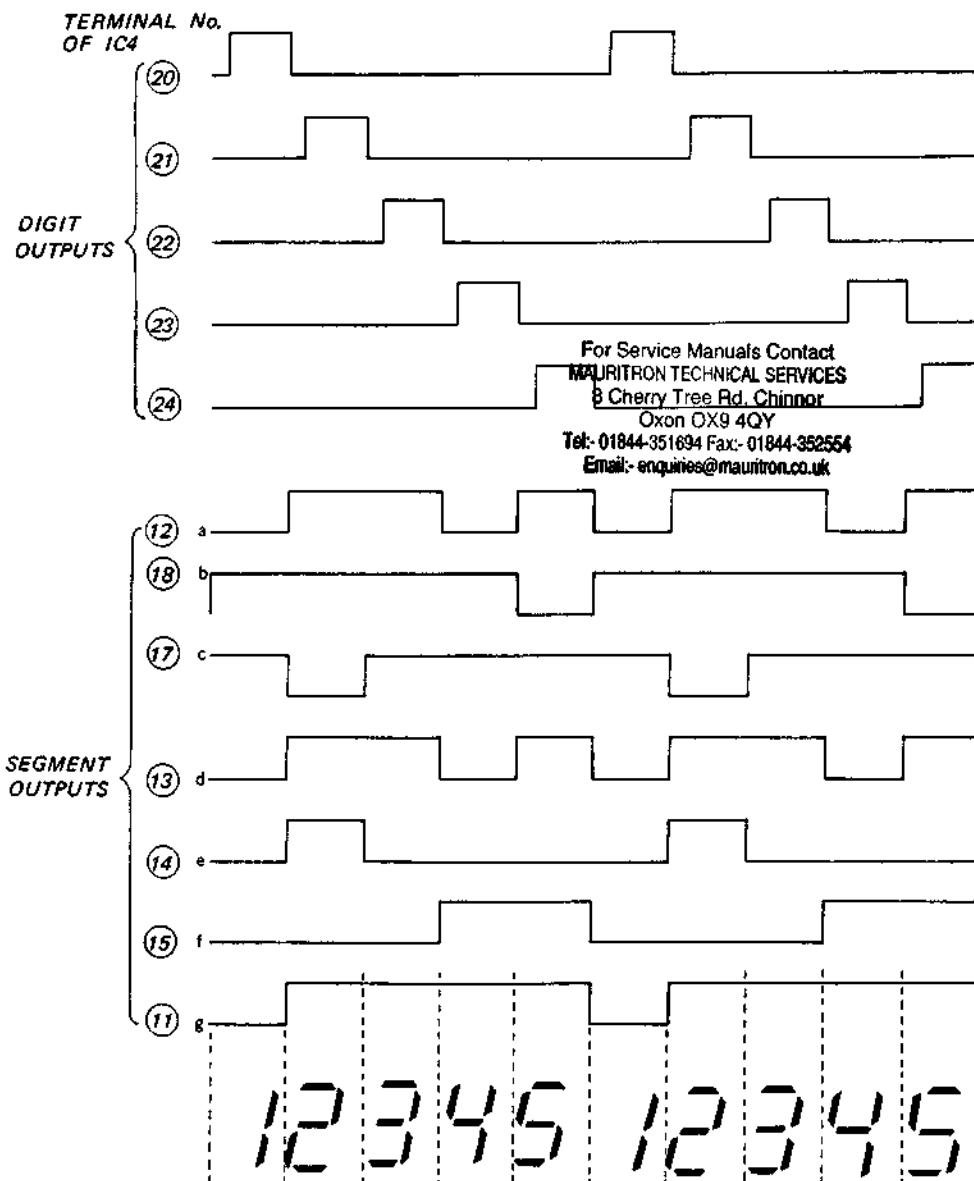

Fig. 39

For SSB reception, the received frequency is set at the carrier position. However, the local oscillation frequency of the transmitter is 2 kHz above or below the carrier frequency, and thus the IF selector adds or subtracts 2 kHz before counting.

Dynamic chart of each signal

An output dynamic chart for 12345 is given below as an example.

When both digit and segment outputs are at H (high) level, the output is on.

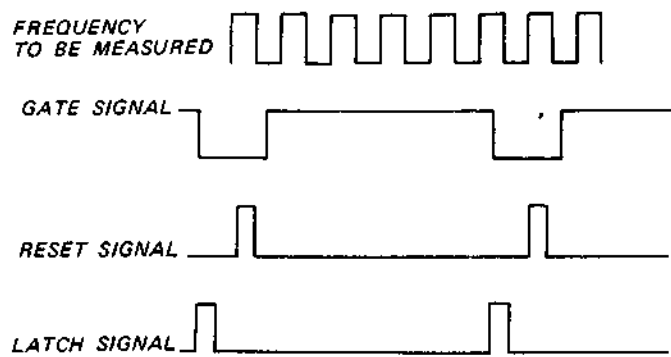

TIMING CHART OF SIGNALS

Fig. 40

ICF-6800W ICF-6800W

1-2. BLOCK DIAGRAM

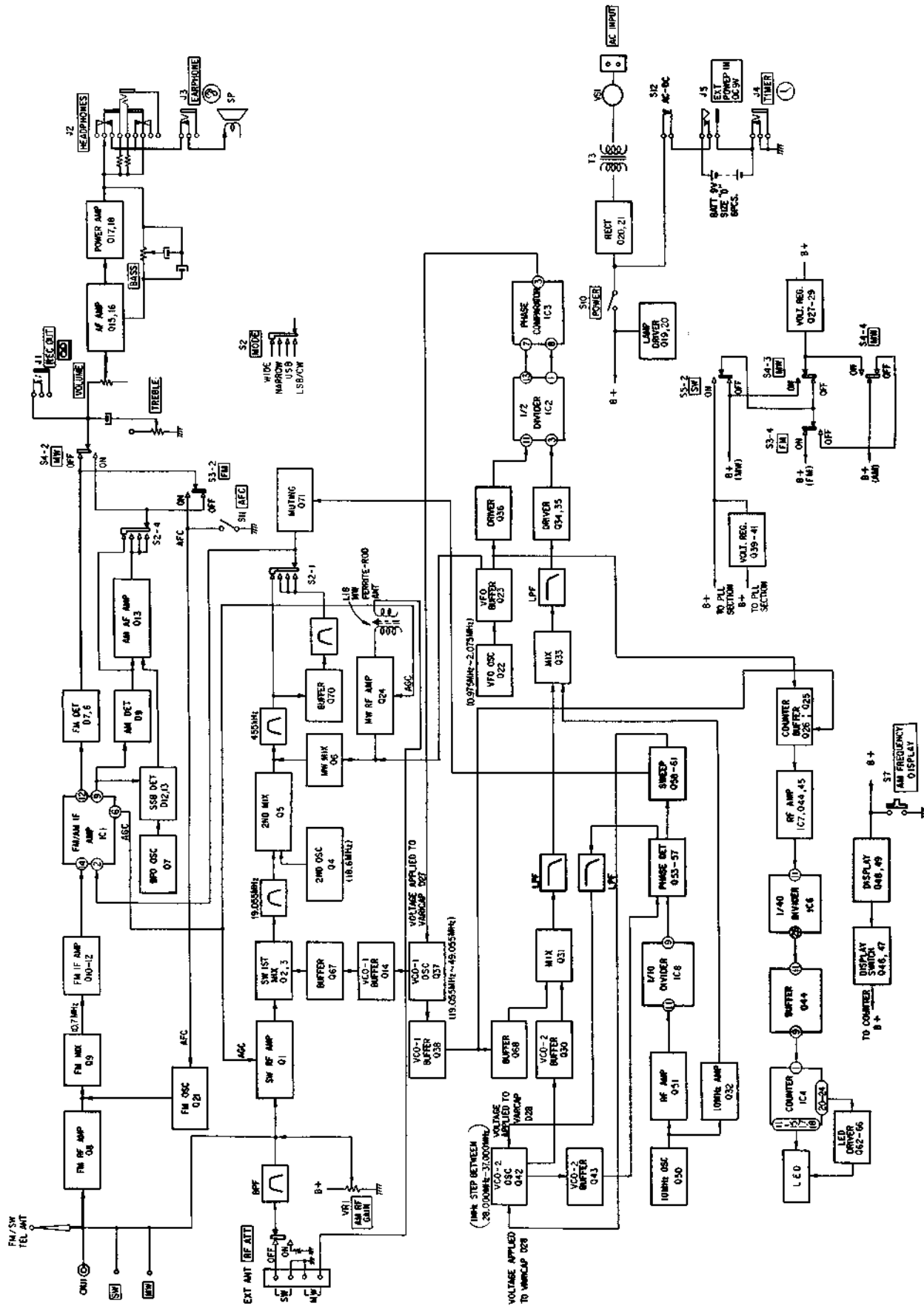

SECTION 2
DISASSEMBLY

• Follow the disassembly procedure in the numerical order given.

• REAR CASE REMOVAL (page 25)

• FRONT PANEL REMOVAL (page 26)

• MIDDLE CASE REMOVAL (page 27)

• DIAL-CORD STRINGINGS (page 35 through 38)

• TOP CASE REMOVAL (page 31)

• PRESELECTION DIAL-CORD STRINGING (2) (Page 37)

Control board can be removed for replacing controls.

• CHASSIS (A) REMOVAL (page 30)

• PRESELECTION BOARD REMOVAL (page 32)

• MAIN CHASSIS REMOVAL (page 28)

• SCALE DRUM DIAL-CORD STRINGING (Page 38)

For scale-drum removal, see page 29.

• MW BOARD REMOVAL (page 33)

• MAIN BOARD REMOVAL (page 29)

• COUNTER BOARD REMOVAL (page 30)

• SCALE DRUM REMOVAL (page 29)

• FM DIAL-CORD STRINGING (Page 35)

For Service Manuals Contact
MAURITRON TECHNICAL SERVICES
8 Cherry Tree Rd, Chinnor
Oxon OX9 4QY
Tel:- 01844-351694 Fax:- 01844-352554
Email:- enquiries@mauritron.co.uk

• REAR CASE REMOVAL

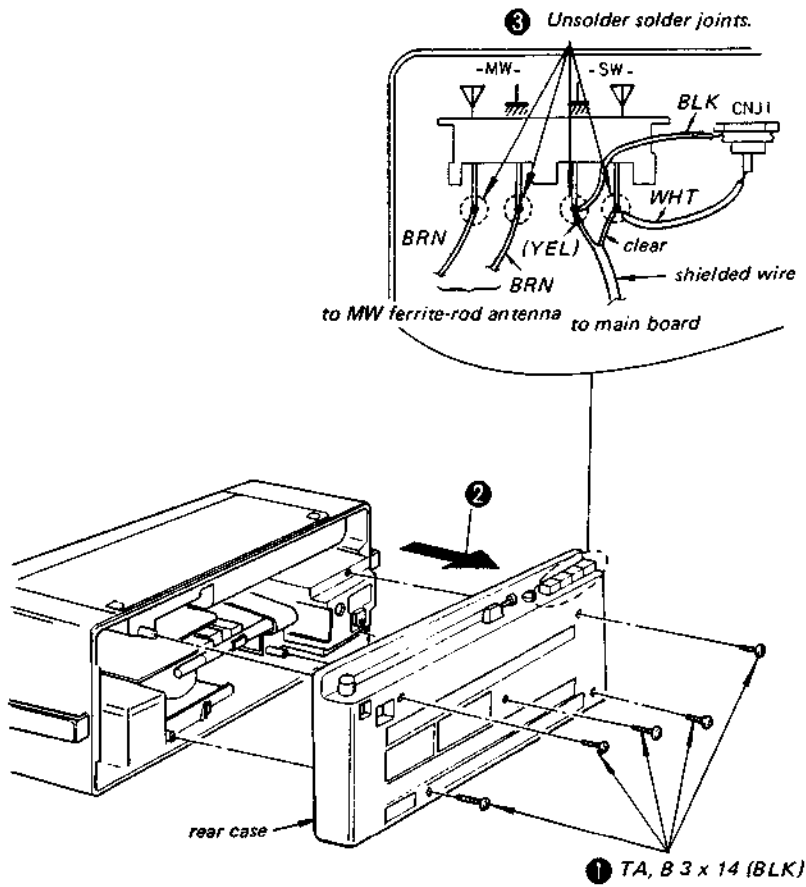

For Service Manuals Contact
MAURITRON TECHNICAL SERVICES
8 Cherry Tree Rd, Chinnor
Oxon OX9 4QY
Tel:- 01844-351694 Fax:- 01844-352554
Email:- enquiries@mauritron.co.uk

• FRONT PANEL REMOVAL

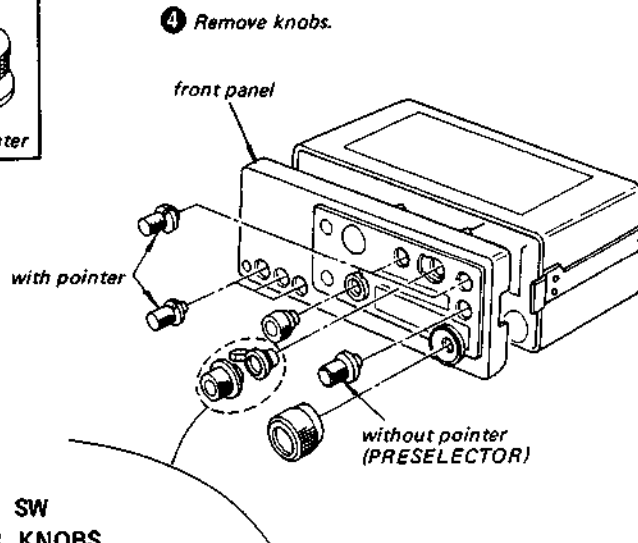
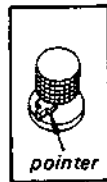
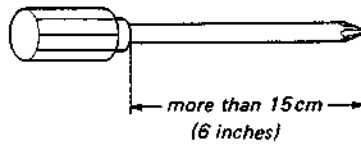
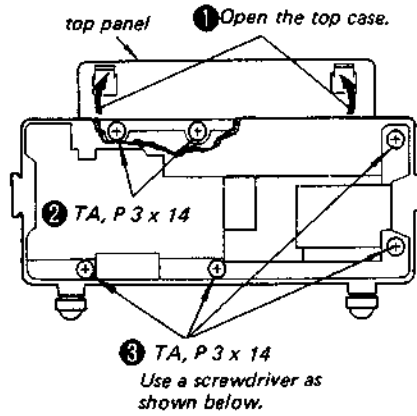

• ATTACHING THE SW BAND SELECTOR KNOBS

1. Set the switch shaft to its full-clockwise stop.

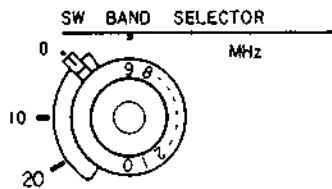

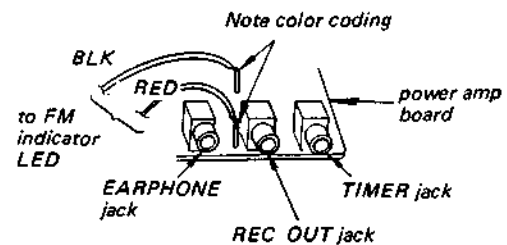

2. Attach the two knobs as shown above.

- 5 Remove six lead wires (speaker, FM indicator LED, MEMO-LITE). Note the color coding of the two lead wires to the FM indicator LED.

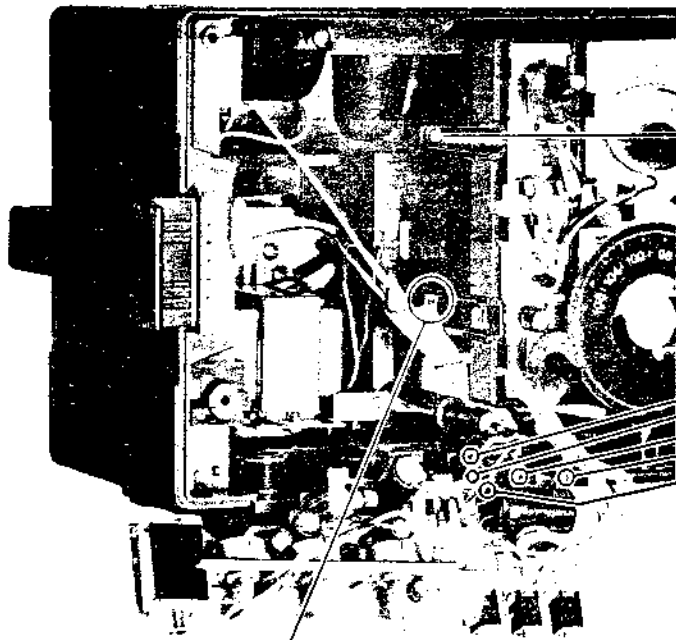
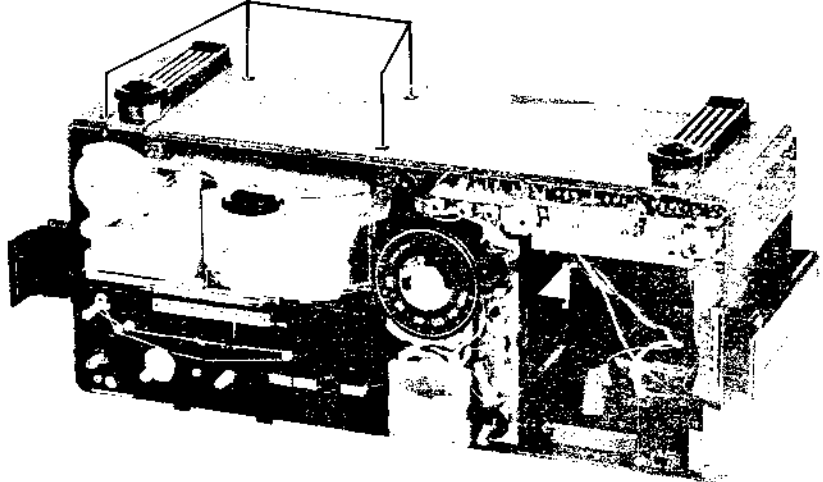

• MIDDLE CASE REMOVAL  1 P3x8



2 TA, PTP 3 x 14 

For Service Manuals Contact
MAURITRON TECHNICAL SERVICES
8 Cherry Tree Rd, Chinnor
Oxon OX9 4QY
Tel: 01844-351694 Fax: 01844-352554
Email: enquires@mauritron.co.uk

- BLK
- RED
- ORG
- GRY
- RED

5 Remove five lead wires. To operate the set in this condition, apply 9 V dc to the indicated terminals.

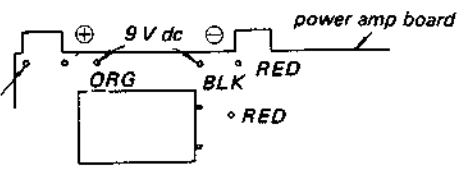

3 Release the claw.

GRY from the battery negative spring.

4 Remove the middle case.

TOP CASE REMOVAL
(Page 31)

Control board can be removed for replacing controls.

PRESELECTOR DIAL-CORD STRINGING (2) (Page 37)

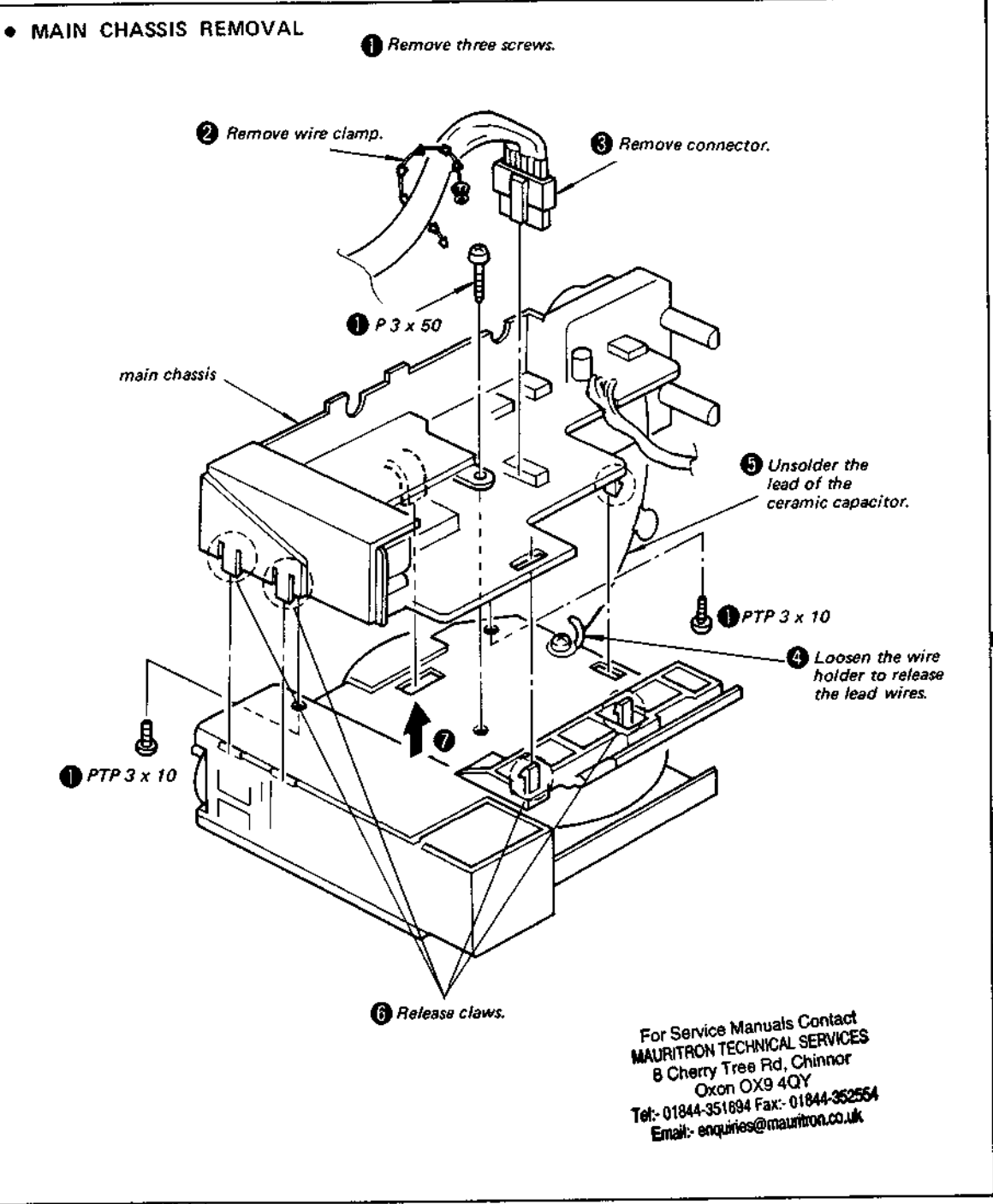

PRESELECTOR BOARD REMOVAL
(Page 38)

PRESELECTOR DIAL-CORD STRINGING (1)
(Page 36)

SCALE-DRUM DIAL-CORD STRINGING
(Page 38)
For scale-drum removal, see page 27.

MW BOARD REMOVAL
(Page 33)

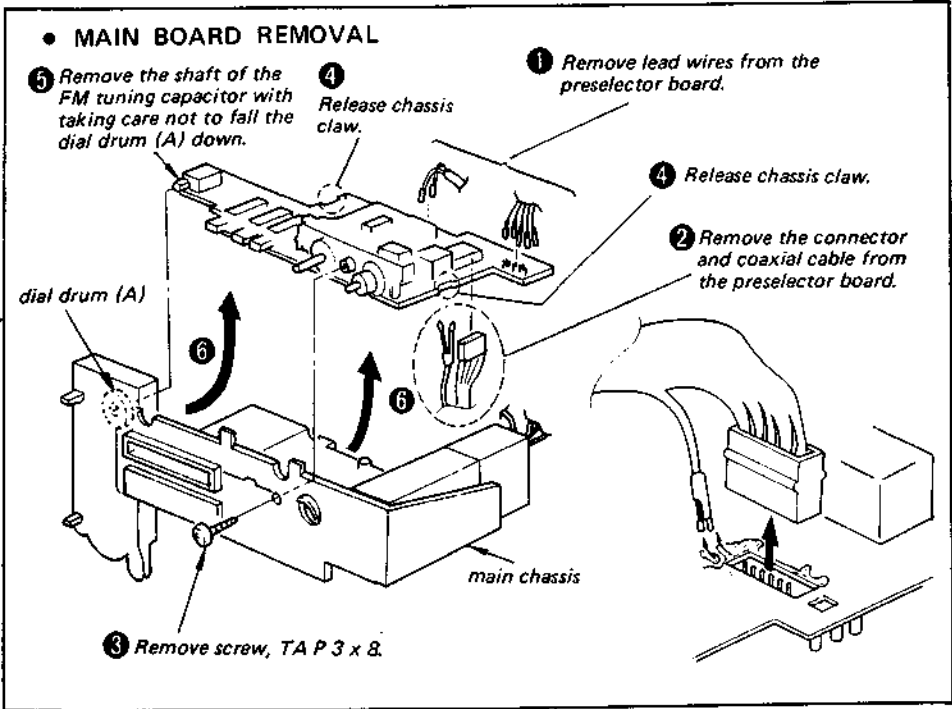

FM DIAL-CORD STRINGING
(Page 34)

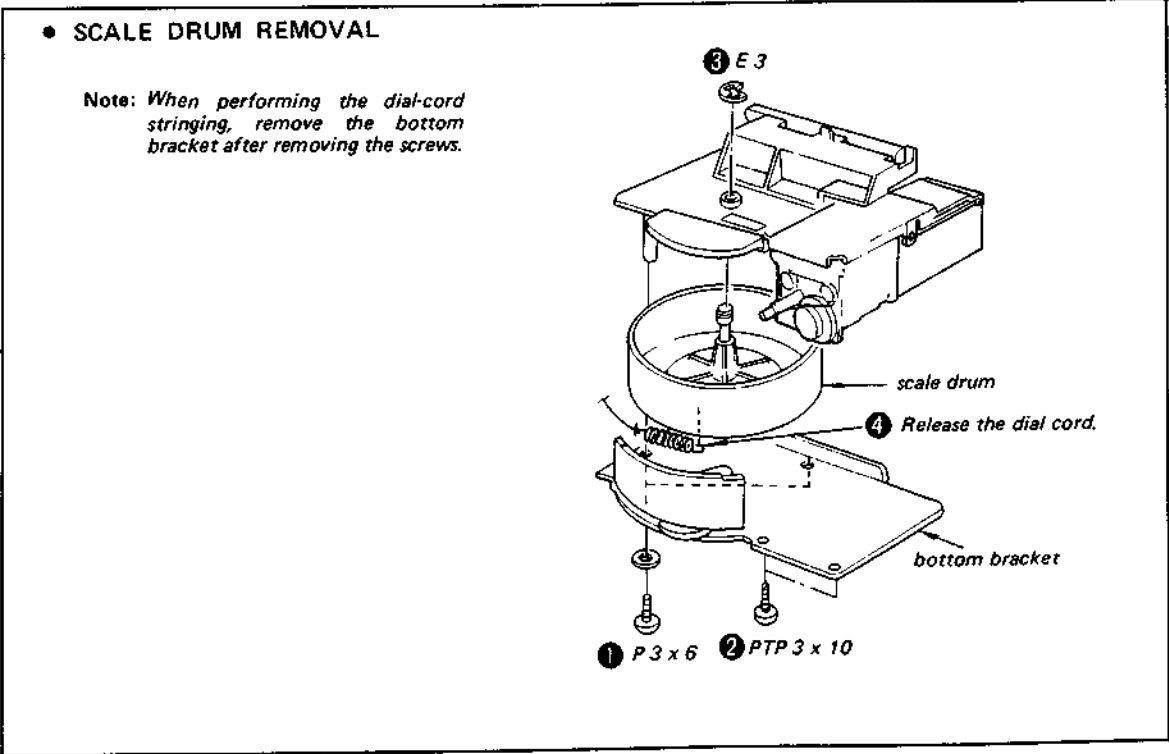

MIDDLE-CASE REMOVAL (Page 27)

• CHASSIS (A) REMOVAL

Perform this removal when any access is required to the parts beneath the chassis (A).

1 P3 x 50

2 TA, P3 x 8

3 Unsolder solder joints at the variable capacitor.

4 Unsolder a lead wire.

5 Release the claw.

chassis (A)



• COUNTER BOARD REMOVAL

1 Release lead wire from the counter board at the main board.

2 PTP 3 x 6

3 holder (C)

4 P3 x 6

5

6 P3 x 4

7 shield case

8

shield case

counter board

For Service Manuals Contact
 MAURITRON TECHNICAL SERVICES
 8 Cherry Tree Rd, Chinnor
 Oxon OX9 4QY
 Tel: 01844-351694 Fax: 01844-352554
 Email: enquiries@mauritron.co.uk

FRONT PANEL REMOVAL
(Page 26)



• **TOP CASE REMOVAL**

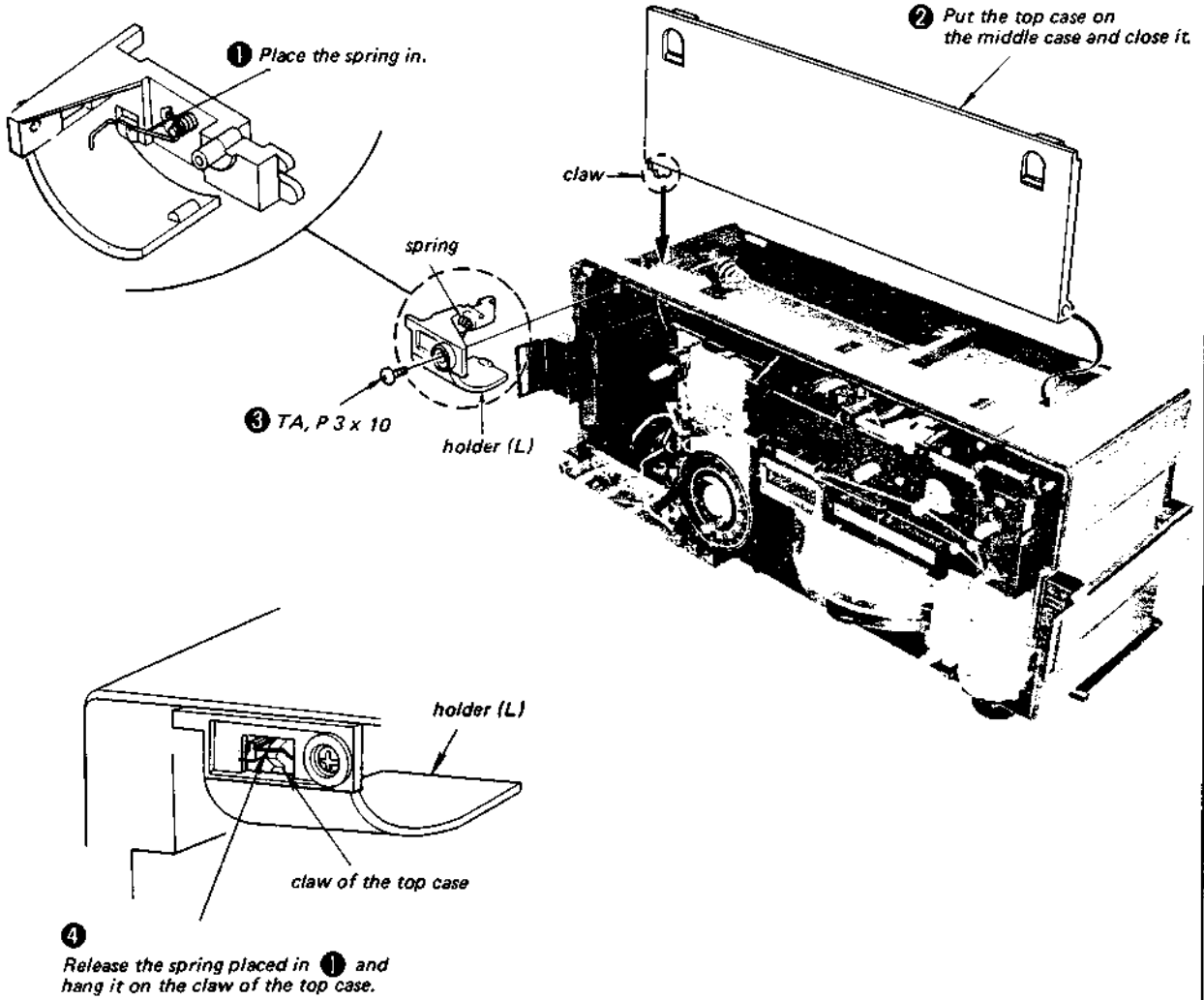

For Service Manuals Contact
MAURITRON TECHNICAL SERVICES
8 Cherry Tree Rd, Chinnor
Oxon OX9 4QY
Tel: 01844-351694 Fax: 01844-352554
Email: enquiries@mauritron.co.uk

MIDDLE-CASE REMOVAL (Page 27)



• PRESELECTOR BOARD REMOVAL

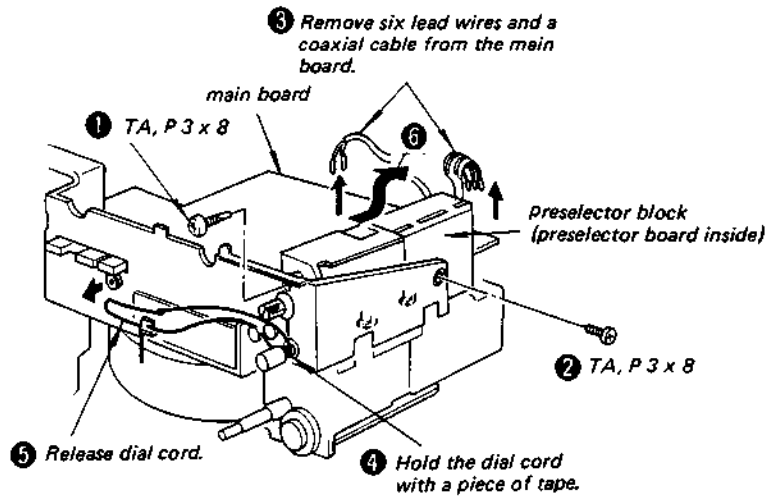

When making checks to the preselector board operation, reconnect the lead wires as follows.

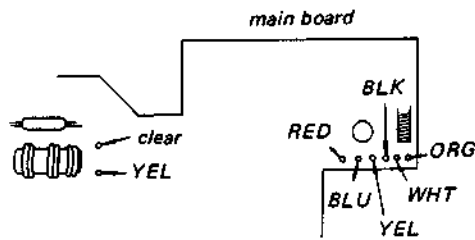

For Service Manuals Contact
MAURITRON TECHNICAL SERVICES
 8 Cherry Tree Rd, Chinnor
 Oxon OX9 4QY
 Tel: 01844-351694 Fax: 01844-352554
 Email: enquiries@mauritron.co.uk

MAIN CHASSIS REMOVAL (page 28)



• MW BOARD REMOVAL

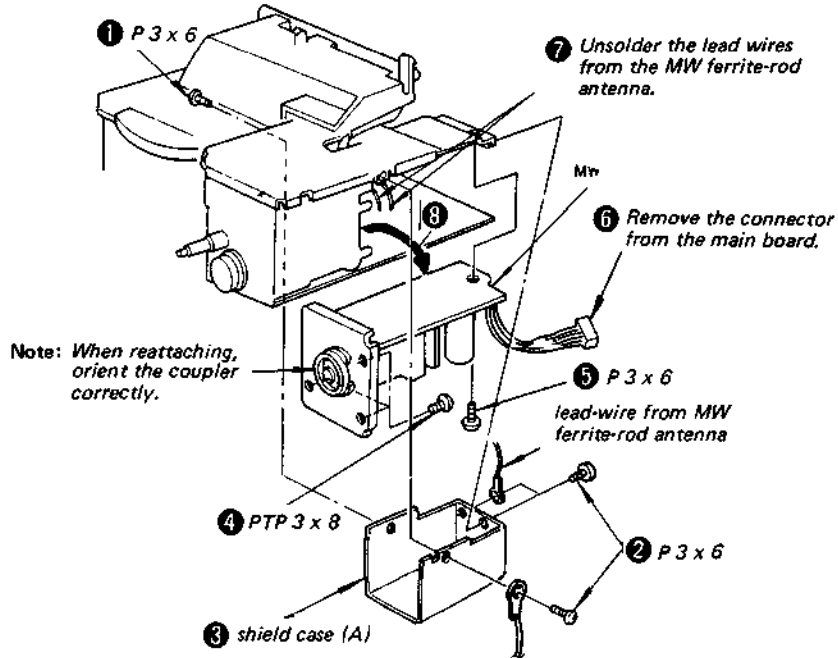

When making checks to the MW-board operation, reconnect the lead wires referring to the following figure, and reconnect the connector removed.

MW BOARD (CONDUCTOR SIDE)

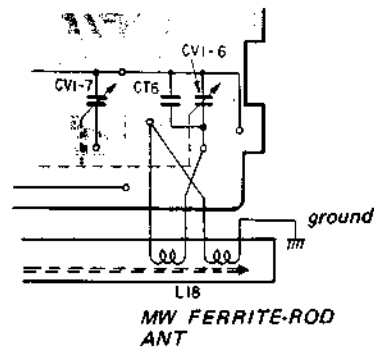

For Service Manuals Contact
MAURITRON TECHNICAL SERVICES
 8 Cherry Tree Rd, Chinnor
 Oxon OX9 4QY
 Tel: 01844-351694 Fax: 01844-352554
 Email: enquiries@mauritron.co.uk

INSTALLATION OF THE TUNING CAPACITOR (CV1)

Note: Perform VCO-2 ADJUSTMENT after the installation.

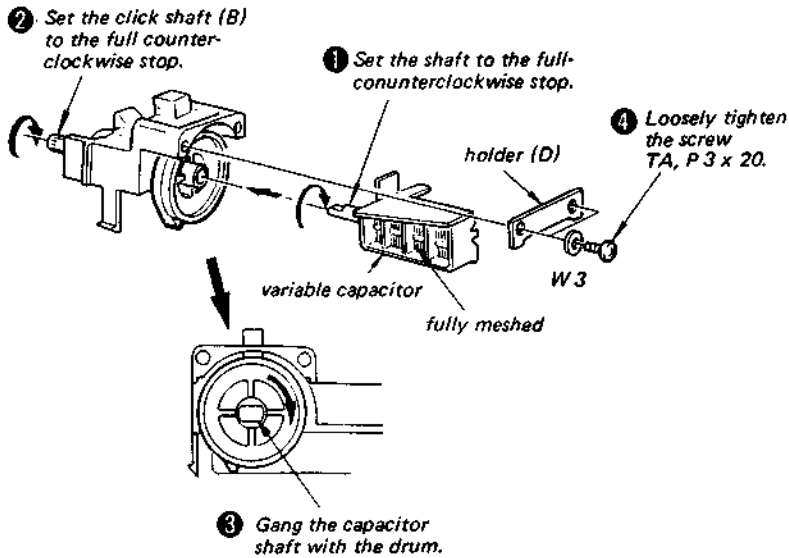

- ⑤ Fully tighten the screw loosely tightened in step ④ while pressing the capacitor in both the directions (A) and (B). Be sure not to press too strong.

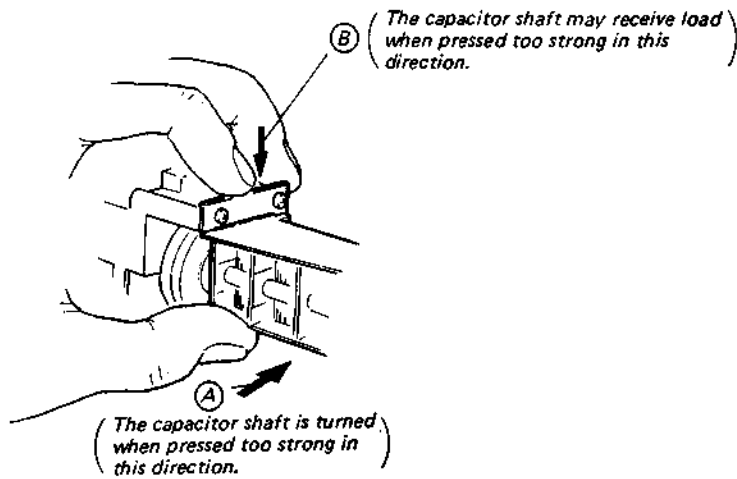

- ⑥ After the installation, check that the capacitor rotor does not move when the capacitor is lightly moved by hand.

MAIN BOARD REMOVAL (Page 29)

• FM DIAL-CORD STRINGING

1. Dial-Cord Preparation

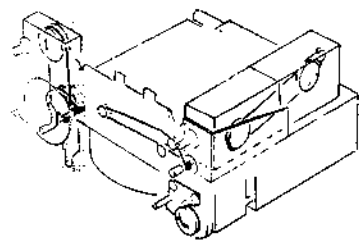
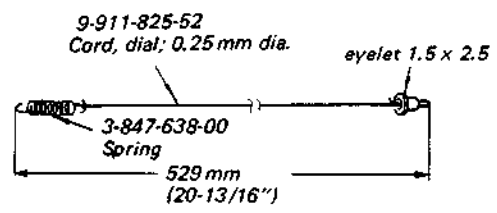

2. Drum Positions

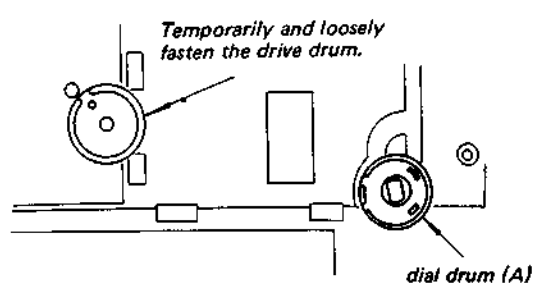

5. Positioning of the Dial Scale (A)

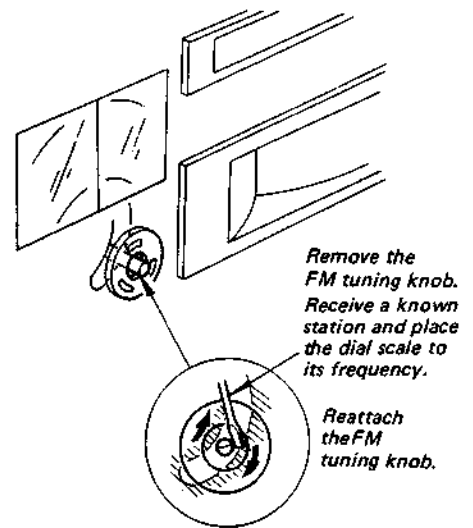

3. Dial-Cord Stringing

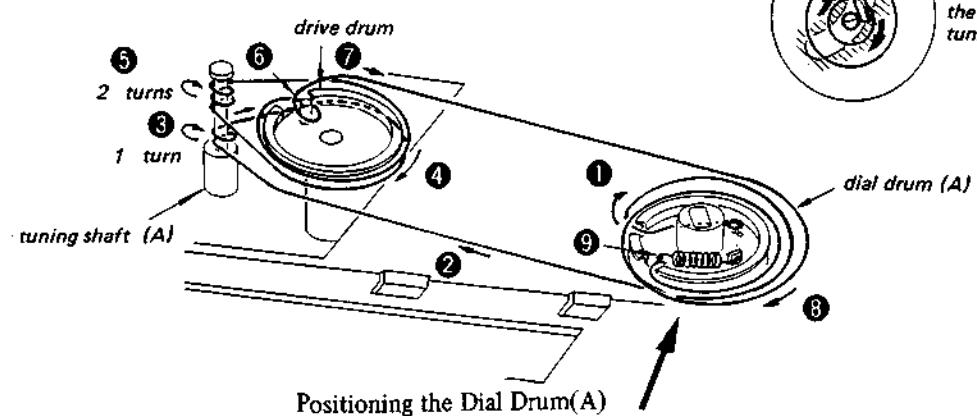

4. Attaching the Dial Drum (A) on the Tuning Shaft.

Set the tuning shaft to the full-clockwise stop (f min). Rotate the dial drum (A) in 90 degrees counterclockwise from the position of the dial-cord stringing.

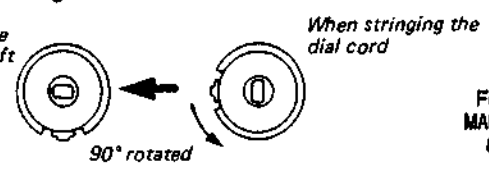

For Service Manuals Contact
MAURITRON TECHNICAL SERVICES
8 Cherry Tree Rd, Chinnor
Oxon OX9 4QY
Tel:- 01844-351694 Fax:- 01844-352554
Email:- enquiries@mauritron.co.uk

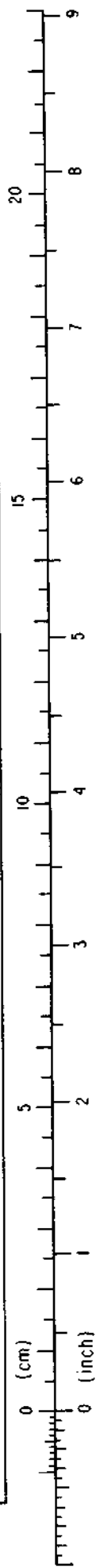

PRESELECTOR BOARD REMOVAL (Page 32)

● PRESELECTOR DIAL-CORD STRINGING (1)

1. Dial-Cord Preparation

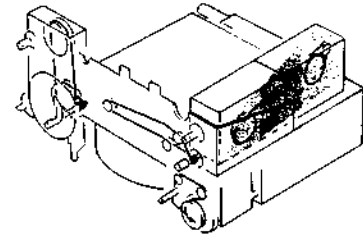
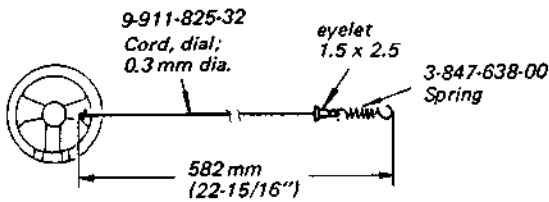

2. Dial-Cord Stringing

Set the PRESELECTOR tuning shaft to the full-clockwise stop. Check that the drum and drum gear are oriented as shown and string the dial cord.

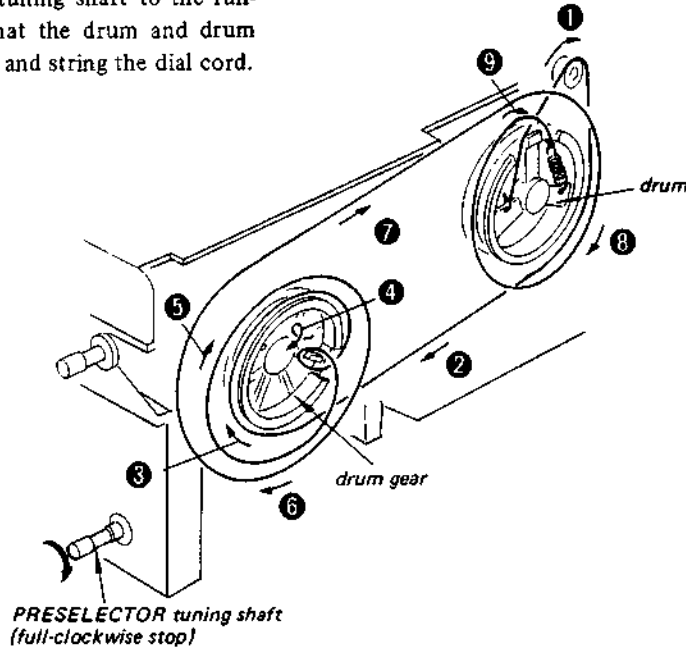

For Service Manuals Contact
MAURITRON TECHNICAL SERVICES
8 Cherry Tree Rd, Chinnor
Oxon OX9 4QY
Tel: 01844-351694 Fax: 01844-352554
Email: enquiries@mauritron.co.uk

FRONT PANEL REMOVAL (Page 26)

● PRESELECTOR DIAL-CORD STRINGING (2)

1. Dial-Cord Preparation

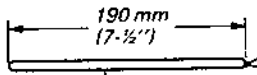

9-911-825-52
Cord, dial; 0.25 mm dia.

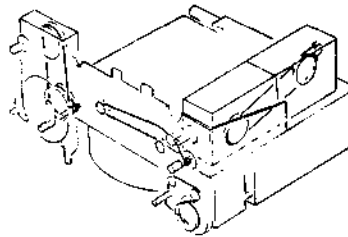

2. Dial-Cord Stringing Preparation

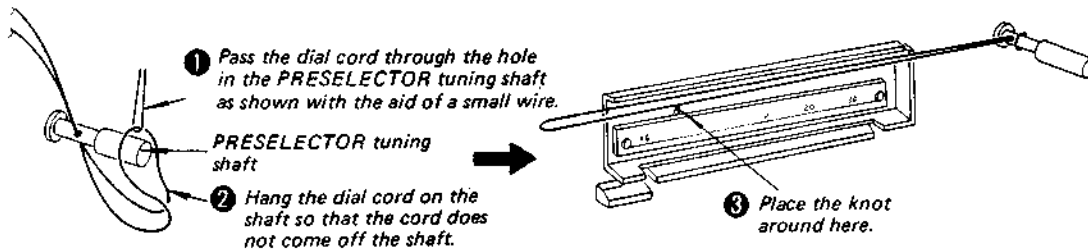

3. Dial-Cord Stringing

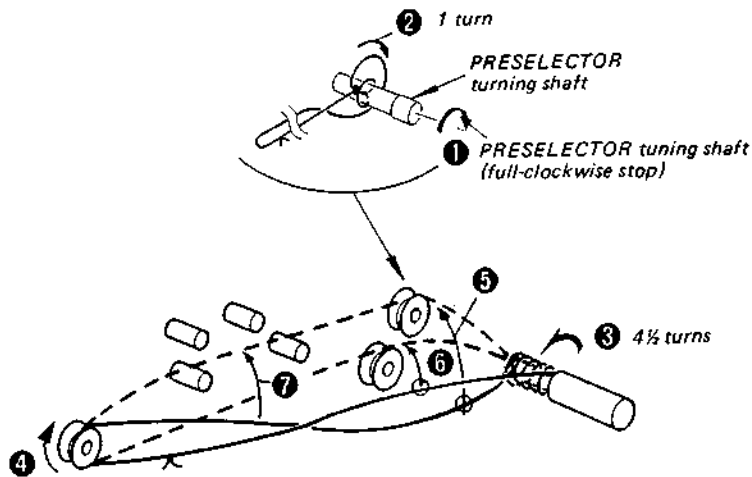

4. Dial-Pointer Setting

Set the PRESELECTOR tuning shaft to the full-counterclockwise stop and position the dial pointer as shown below.

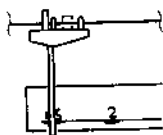

MIDDLE-CASE REMOVAL (Page 27)

• SCALE-DRUM DIAL-CORD STRINGING

1. Dial-Cord Preparation

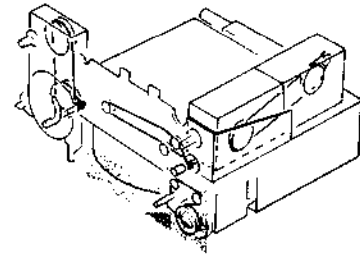
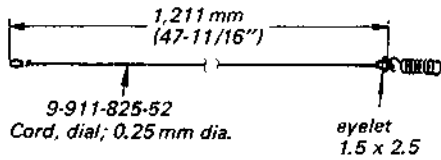

2. Dial-Cord Stringing

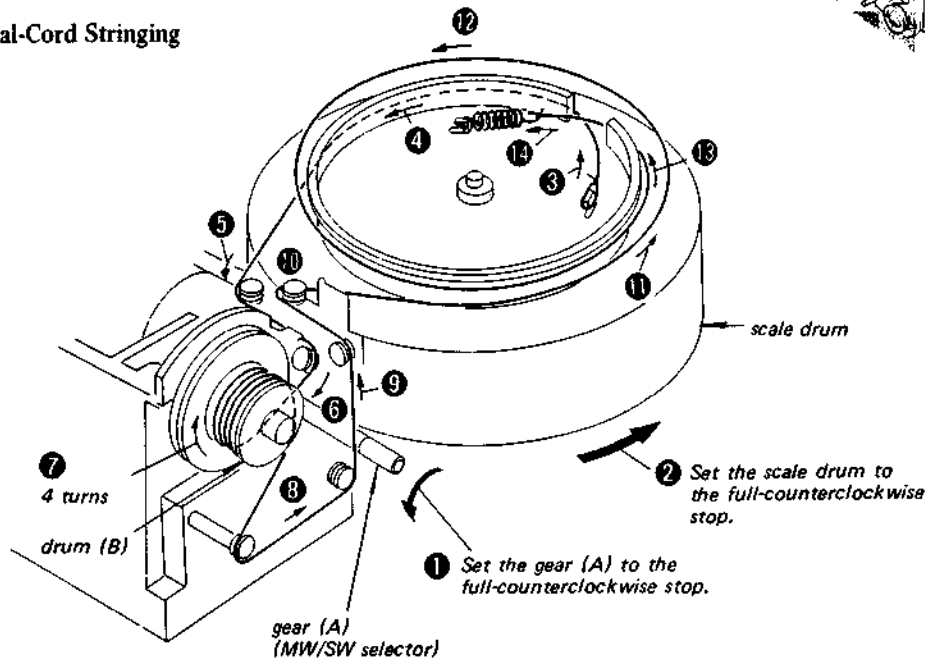

3. Dial-Scale Setting

- 1) Hold the gear (A) and strongly move the scale drum so that the cursor on the transparent plate places on the dial scale when the SCALE ADJ knob is turned to the left- and right-most stops.

- 2) Adjust the SCALE ADJ knob so that the cursor places on the position shown by (A).
- 3) Set the gear (A) to the full-counterclockwise stop. Hold the gear (A) and move the scale drum strongly so that the dial scale places at the position as shown below.

Note: The dial cord slips on the drum (B).

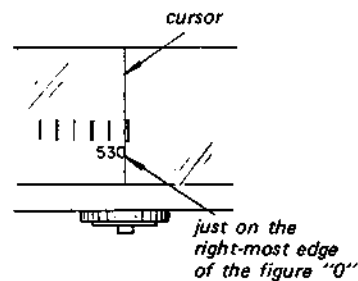
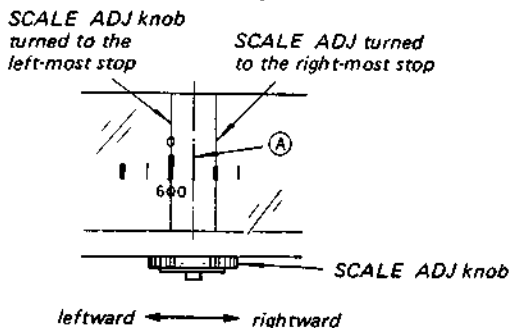

SECTION 3 ADJUSTMENTS

1. FM IF ALIGNMENT
2. FM FREQUENCY COVERAGE ADJUSTMENT
3. FM TRACKING ADJUSTMENT

Procedure:

- Repeat the procedures in each adjustment several times, and the frequency coverage and tracking adjustments should be finally done by the trimmer capacitors.

Setting:

BAND SELECTOR switch: FM
 AFC switch: OFF
 VOLUME control: MAX
 TONE controls: mechanical mid positions

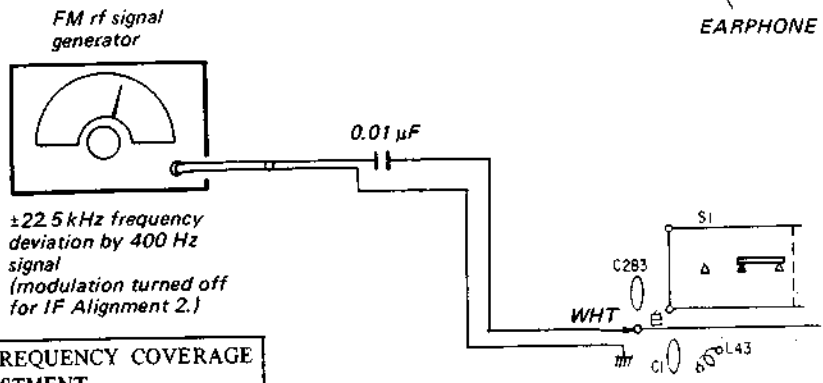

FM FREQUENCY COVERAGE ADJUSTMENT	
Adjust for a maximum reading on VOM ①.	
109.5 MHz (108 MHz)	86.5 MHz (87.5 MHz)
CT4	L17

() : In West Germany

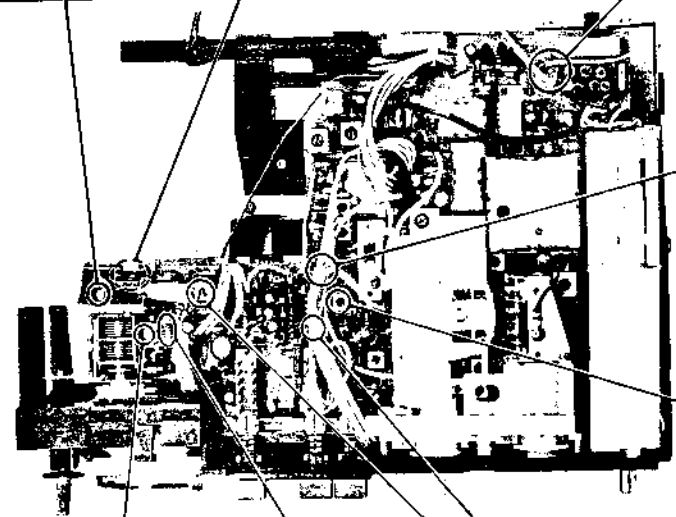
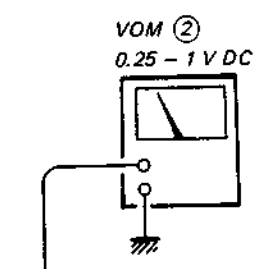
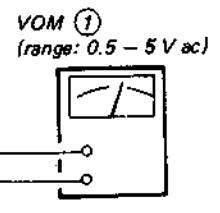

FM IF ALIGNMENT 2 (10.7 MHz without modulation)	
Adjust for 0 V reading on VOM ②.	
IFT F3	

CT3	L13
109.5 MHz (108 MHz)	86.5 MHz (87.5 MHz)
Adjust for a maximum reading on VOM ①.	
FM TRACKING ADJUSTMENT	

IFT-F2
IFT-F1
Adjust for a maximum reading on VOM ①.
FM IF ALIGNMENT 1 (10.7 MHz with modulation)

() : In West Germany

4. MW IF ALIGNMENT

5. MW TRACKING ADJUSTMENT

Setting:

BAND SELECTOR switch: MW
 VOLUME control: MAX
 TONE controls: mechanical mid position

For Service Manuals Contact
MAURITRON TECHNICAL SERVICES
 8 Cherry Tree Rd, Chinnor
 Oxon OX9 4QY
 Tel:- 01844-351694 Fax:- 01844-352554
 Email:- enquiries@mauritron.co.uk

Procedure:

- Repeat the procedures in each adjustment several times, and the frequency coverage and tracking adjustments should be finally done by the trimmer capacitors.

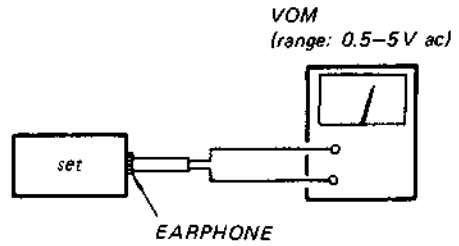
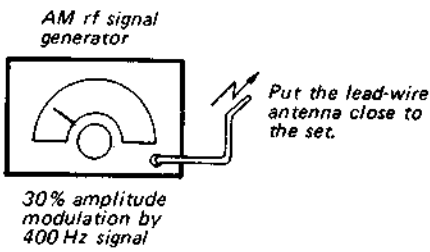

MW TRACKING ADJUSTMENT ①		MW TRACKING ADJUSTMENT ②	
Adjust for a maximum reading on VOM.		Adjust for a maximum reading on VOM.	
620 kHz	L18	620 kHz	1,400 kHz
		L19	CT6

CFT (Serial No. up to 30,000)
 IFT-A5 (Serial No. 30,001 and later)

455 kHz

Adjust for a maximum reading on VOM.

MW IF ALIGNMENT

6. VFO FREQUENCY COVERAGE ADJUSTMENT (MW FREQUENCY COVERAGE ADJUSTMENT)

Setting:

BAND SELECTOR switch: MW
 VOLUME control: MAX
 TONE controls: mechanical mid position

Step	Position of gear (A) (shaft to select MW or SW)	Adjust	Frequency Counter Indication
1	full-counter-clockwise stop	L15	520 kHz (±3 kHz)
2	full counter-clockwise stop	CT5	1,620 kHz (±3 kHz)
3	Repeat steps 1 and 2 if necessary.		

For Service Manuals Contact
MAURITRON TECHNICAL SERVICES
 8 Cherry Tree Rd, Chinnor
 Oxon OX9 4QY
 Tel: 01844-351894 Fax: 01844-352554
 Email: enquiries@mauritron.co.uk

Adjustment Location:
 - main board -

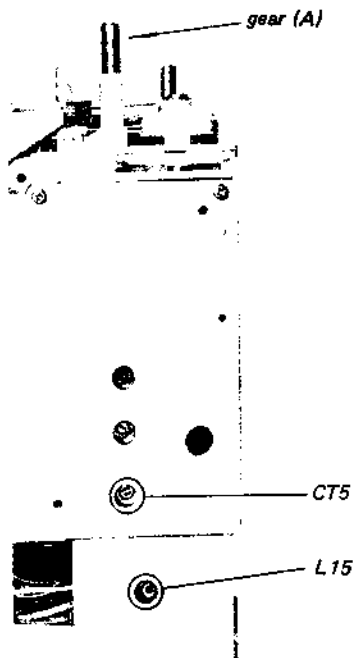

7. MIXER BALANCE-2 ADJUSTMENT

Setting:

BAND SELECTOR switch: SW
 MODE switch: WIDE
 AM RF GAIN control: MAX
 SW-ANT switch: ROD

Procedure:

AM rf signal generator

VOM (range: 0.5-5 V ac)

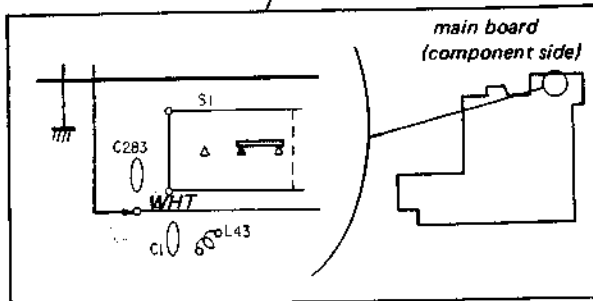
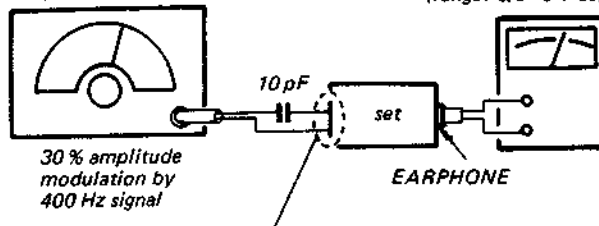

1. Tune in to 20.1 MHz.

2.

AM rf signal generator frequency	PRESELECTOR position	Adjust	VOM reading
19.055 MHz	around 19 MHz for a maximum output level	VT2	minimum

Adjustment Location:

- main board -

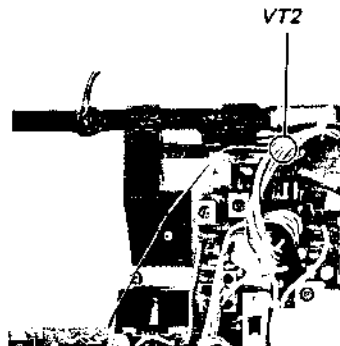

8. 10 MHz OSCILLATOR OUTPUT LEVEL ADJUSTMENT

Setting:

BAND SELECTOR switch: SW

Procedure:

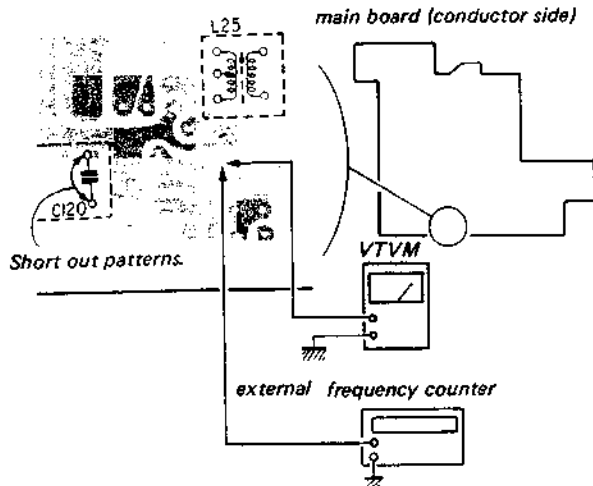

1. Short out the patterns as shown above.
2. Adjust L25 for a maximum reading on the VTVM. The frequency counter should read 10 MHz ± 100 Hz. If not, adjust the value of C213.

C213	3 pF	Frequency lowers
	4 pF	
	5 pF	

Adjustment Location:

- main board -

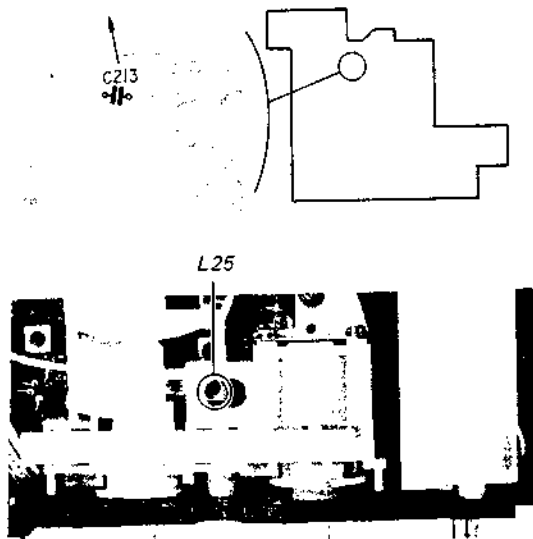

9. 18.6 MHz OSCILLATOR FREQUENCY ADJUSTMENT

Setting:

BAND SELECTOR switch: SW

Procedure:

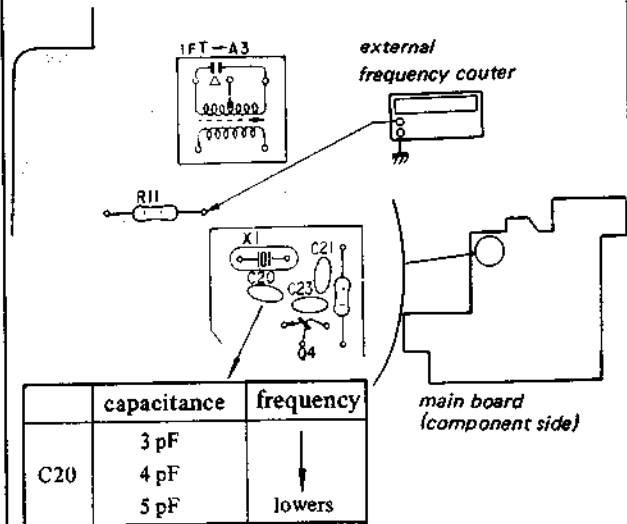

Adjust the value of C20 so that the frequency reading on the frequency counter becomes 18.6 MHz ± 250 Hz.

For Service Manuals Contact
MAURITRON TECHNICAL SERVICES
 8 Cherry Tree Rd, Chinnor
 Oxon OX9 4QY
 Tel: 01844-351694 Fax: 01844-352554
 Email: enquiries@mauritron.co.uk

10. BFO ADJUSTMENT

Setting:

BAND SELECTOR switch: SW

Procedure:

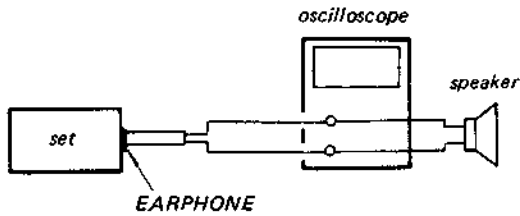

1. Set the receiver to tune in to 20.0 MHz.
2. Adjust AM RF GAIN control to set the TUNING meter to about "5".
3. Adjust L38 by setting the MODE switch to USB and LSB/CW alternately so that the waveforms and tones in both modes become the same.

Adjustment Location:

- main board -

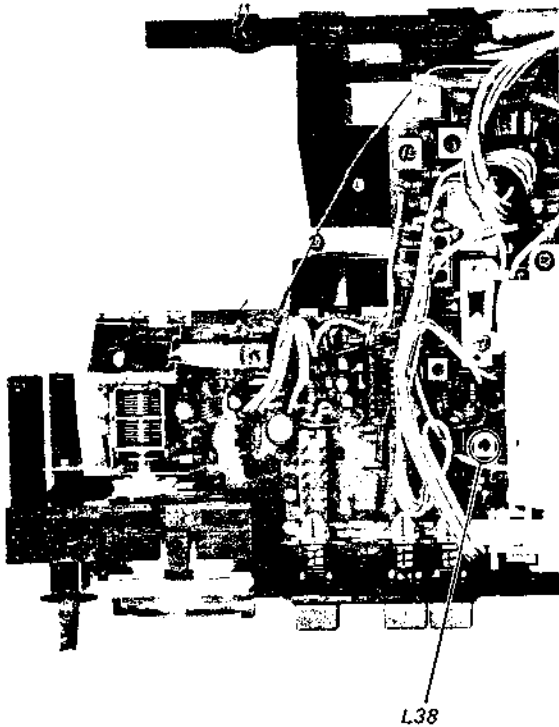

11. 1st IF ALIGNMENT

Setting:

BAND SELECTOR switch: SW

Procedure:

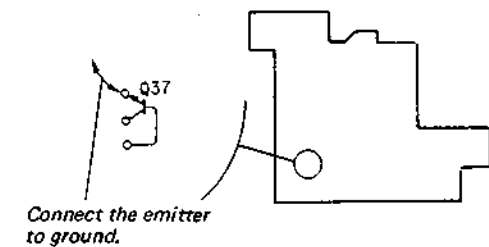
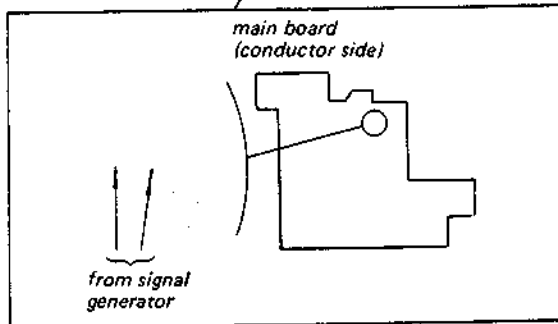
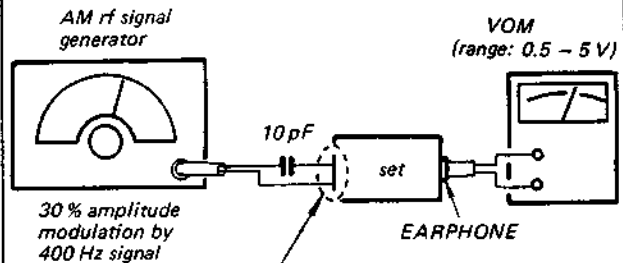

AM rf signal generator frequency	Adjust	VOM reading
19.055 MHz	IFT-A1 IFT-A2 IFT-A3	maximum

Adjustment Location:

- main board -

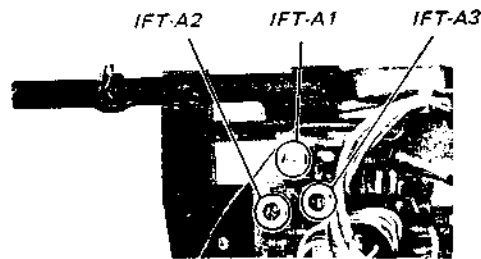

12. PRESELECTOR FREQUENCY COVERAGE AND TRACKING ADJUSTMENT

Setting:

BAND SELECTOR switch: SW
 MODE switch: WIDE

Procedure:

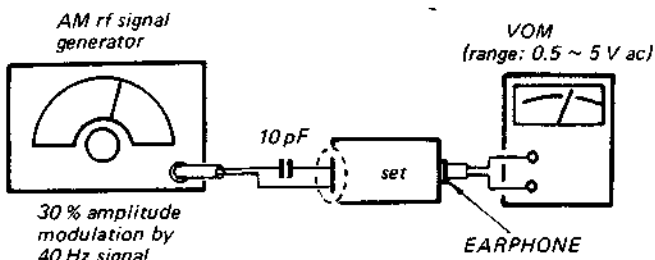

Core positions of L7 and L8

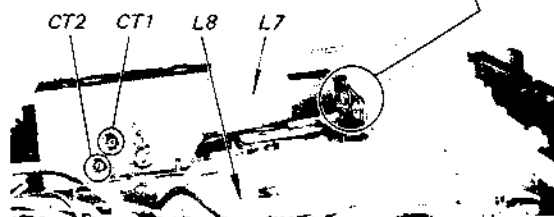
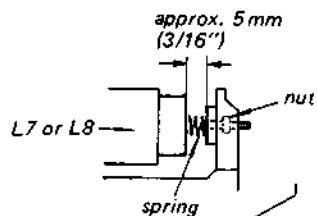

1. Turn the PRESELECTOR shaft to make the springs of L7 and L8 visible as shown on the right.
2. Adjust the nuts so that the springs expose approximately 5 mm (3/16")
- 3.

Step	Rf signal generator frequency	PRESELECTOR shaft position	Adjust	VOM reading
1	1.6 MHz	full-counterclockwise	nut of L7 and L8	maximum
2	30 MHz	full-clockwise	CT1 CT2	
3	7 MHz	Tune in the set to 7 MHz	nut of L7	

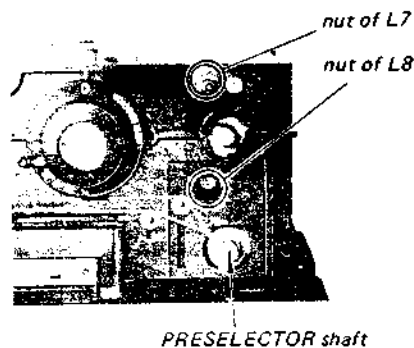

Repeat step 1 to confirm the maximum indication of the VOM. If not, repeat steps 1 through 3.

For Service Manuals Contact
MAURITRON TECHNICAL SERVICES
 8 Cherry Tree Rd, Chinnor
 Oxon OX9 4QY
 Tel: 01844-351694 Fax: 01844-352554
 Email: enquiries@mauritron.co.uk

13. VCO1 FREQUENCY COVERAGE ADJUSTMENT

WHEN THE INTERNAL FREQUENCY COUNTER IS DEFECTIVE

Note: Perform this adjustment from the lowest frequency.

Perform the adjustment from the step 1 to 3 successively.

Setting:

BAND SELECTOR switch: SW

Procedure:

Note: For all the steps, disable VCO2 by touching CV1-11 with a finger as shown below.

external frequency counter

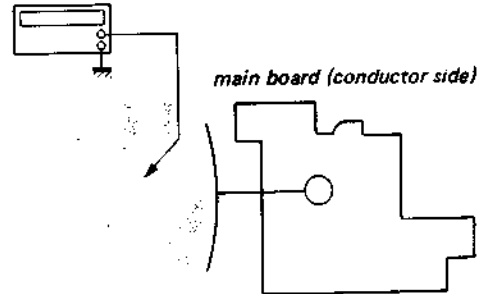

STEP	SW BAND SELECTOR	MW/SW TUNING DIAL	Adjust	INTERNAL FREQUENCY COUNTER IS NORMAL	INTERNAL FREQUENCY COUNTER IS DEFECTIVE
				INTERNAL FREQUENCY COUNTER INDICATION	EXTERNAL FREQUENCY COUNTER INDICATION
1. (SW1)	10 MHz switch ... 0 1 MHz switch ... 0*	full-counter-clockwise	L34	2145 ± 30 kHz (2115 – 2175 kHz)	21200 ± 30 kHz (21170 – 21230 kHz)
	10 MHz switch ... 0 1 MHz switch ... 9	full clockwise	CT8	11045 ± 30 kHz (11015 – 11075 kHz)	30100 ± 30 kHz (30070 – 30130 kHz)
2. (SW2)	10 MHz switch ... 10 1 MHz switch ... 0	full-counter-clockwise	L33	11745 ± 30 kHz (11715 – 11775 kHz)	30800 ± 30 kHz (30770 – 30830 kHz)
	10 MHz switch ... 10 1 MHz switch ... 9	full clockwise	CT10	20745 ± 30 kHz (20715 – 20775 kHz)	39800 ± 30 kHz (39770 – 39830 kHz)
3. (SW3)	10 MHz switch ... 20 1 MHz switch ... 0	full-counter-clockwise	L32	21745 ± 30 kHz (21715 – 21775 kHz)	40800 ± 30 kHz (40770 – 40830 kHz)
	10 MHz switch ... 20 1 MHz switch ... 9	full clockwise	CT9	30645 ± 30 kHz (30615 – 30675 kHz)	49700 ± 30 kHz (49670 – 49730 kHz)

*: Loosen the selector knob a bit and turn and set to "0".

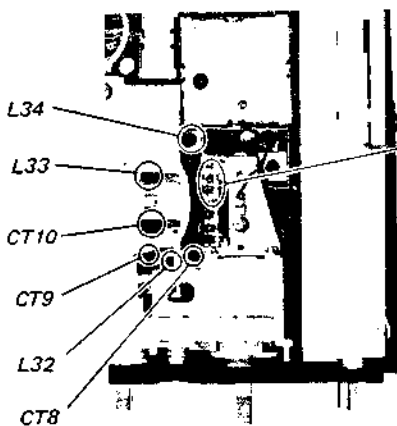
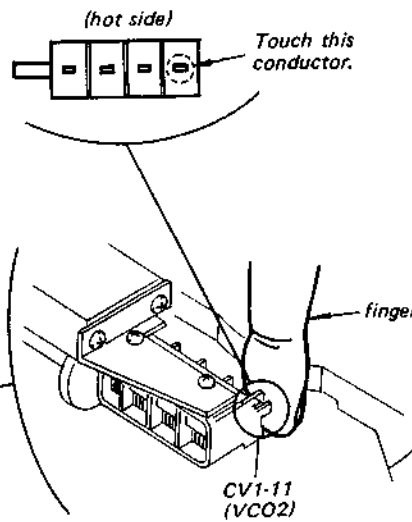

For Service Manuals Contact
MAURITRON TECHNICAL SERVICES
 8 Cherry Tree Rd, Chinnor
 Oxon OX9 4QY
 Tel: 01844-351694 Fax: 01844-352554
 Email: enquiries@mauritron.co.uk

MEMO

For Service Manuals Contact
MAURITHON TECHNICAL SERVICES
8 Cherry Tree Rd, Chinnor
Oxon OX9 4QY
Tel: 01844-351694 Fax: 01844-352554
Email: enquiries@maurithon.co.uk

14. VCO2 ADJUSTMENT

Note: This adjustment may not be made if the variable capacitor CV1-8-11 of VCO2 is installed improperly when it is replaced. Refer to the capacitor installation on page 34.

Procedure:

1. Disable the sweep circuit as shown below.

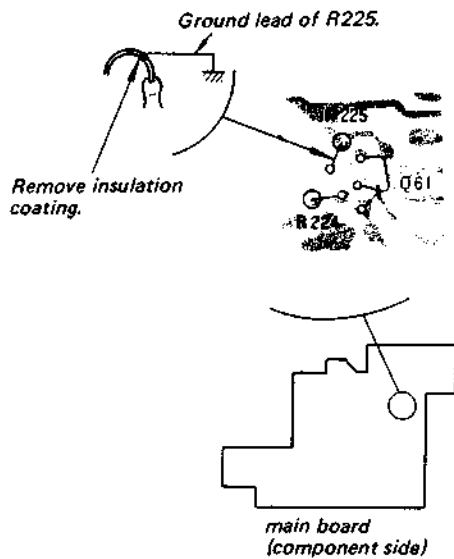

2. BAND SELECTOR switch: MW
3. Turn the MW/SW TUNING DIAL to obtain a 600 kHz indication on the internal counter.
4. MODE switch: WIDE
BAND SELECTOR switch: SW
5. SW BAND SELECTOR: any frequency between 10,000 and 19,000 kHz.

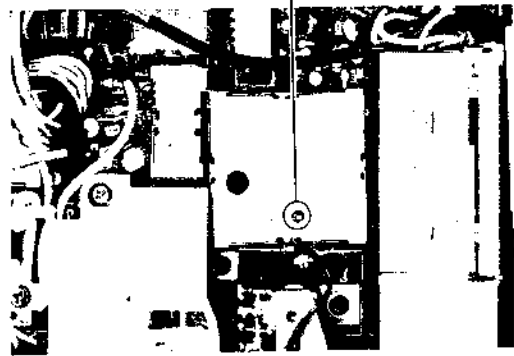
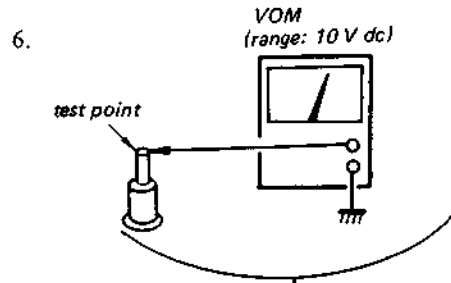

Note: Continue the steps when the circuit of VCO 2 is changed or the phase detector (Q53, Q55-Q57) is replaced. In other cases, skip the steps 7 through 10.

7. Set the SW BAND SELECTOR switches as shown below to obtain a 15,500 kHz indication on the counter.

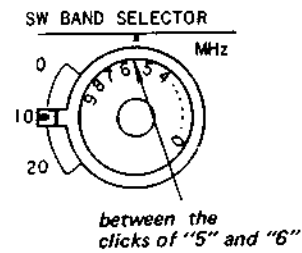

(continued on next page)

8. Adjust VT1 so that VOM connected in step 6 indicates approximately 3.5 V. Keep the frequency indication on the frequency in 15,500 kHz by fine adjusting SW BAND SELECTOR, because the frequency changes when VT1 is adjusted.
9. SW BAND SELECTOR switches: 10 MHz
10. Adjust L36 so that the frequency counter indicates just 10,000 kHz.
11. SW BAND SELECTOR switches: 19 MHz
12. Adjust CT11 so that the frequency counter indicates just 19,000 kHz.
13. Perform step 7. Read the indication of the VOM as connected in step 6. (**A** V)
14. SW BAND SELECTOR: 15 MHz
15. Slowly turn the 1 MHz-step SW BAND SELECTOR switch from "5" to "6" observing the VOM indication. The VOM indication gradually lowers and suddenly goes back up to the first reading. Read the VOM indication just before the reading goes back (**B** V). This should happen between 15,000 and 16,000 kHz.
16. Set the 1 MHz-step SW BAND SELECTOR switch to "5" (15,000 kHz).
17. Gradually turn the 1 MHz-step SW BAND SELECTOR switch from "5" to "4" observing the VOM indication. The VOM indication gradually rises and suddenly goes down to the first reading at a point. Read the VOM indication just before the reading drops. (**C** V). This should happen between 14,000 and 15,000 kHz.
18. **A** V, **B** V and **C** V become as follows.

$$\text{(A V) - (B V) = (C V) - (A V)}$$

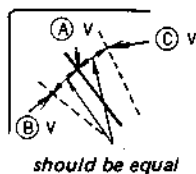

If not, perform steps 7, 8 and 13 through 18.

19. Set the 1MHz-step SW BAND SELECTOR switch to "0".
20. Adjust L36 so that the VOM reading becomes **A** V and the counter indicates 10,000 kHz.
21. Set the 1 MHz-step SW BAND SELECTOR switch to "9".

22. Adjust CT11 so that the VOM reading becomes **A** V and the counter indicates 19,000 kHz.
23. Turn the 1 MHz-step SW BAND SELECTOR switch from "0" to "9" successively. The frequency counter should indicate 10,000 kHz, 11,000, kHz 19,000 kHz respectively. If not, repeat steps 1 through 22.
24. Remove the grounding wire installed in step 1.

Adjustment Location:

- main board -

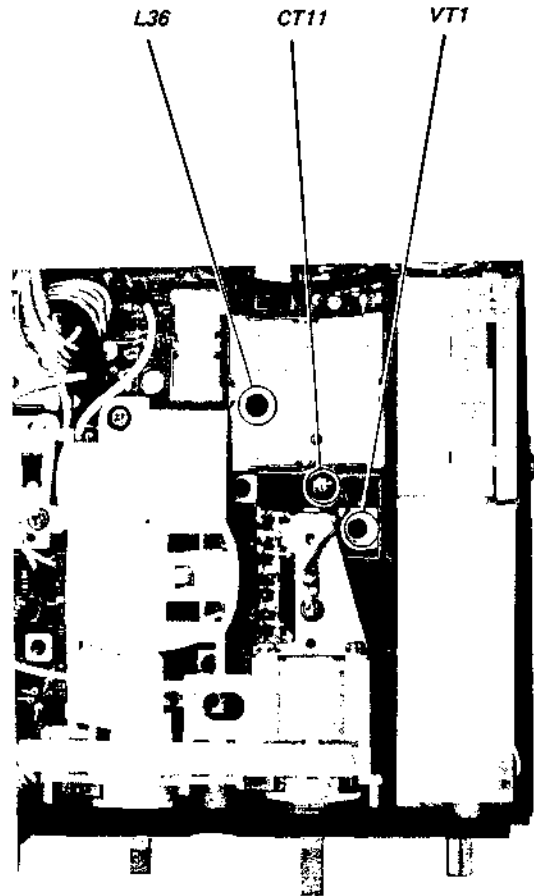

For Service Manuals Contact
MAURITRON TECHNICAL SERVICES
 8 Cherry Tree Rd, Chinnor
 Oxon OX9 4QY
 Tel: 01844-351694 Fax: 01844-352554
 Email: enquiries@mauritron.co.uk

SECTION 4 DIAGRAMS

• Semiconductor Leads Layout

3SK37-62

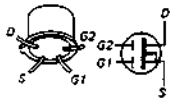

2SK23A-840
2SK23A-824

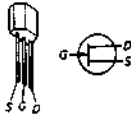

2SC668

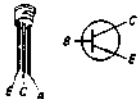

2SC1364

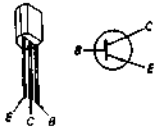

2SK42-2

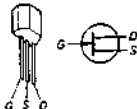

2SA893

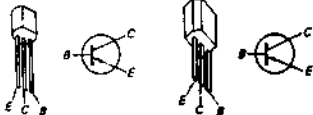

2SA772-14

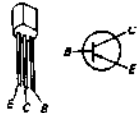

2SC930
2SC1474

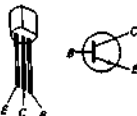

2SA861

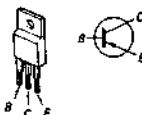

2SC930

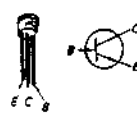

2SC710

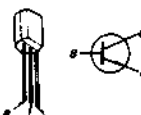

2SK107-24



2SA893

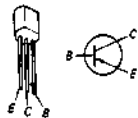

2SA677

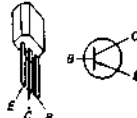

2SK58

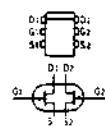

2SC710-13

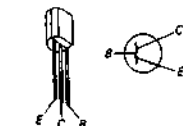

2SC1364

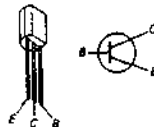

2SC633

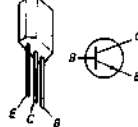

IC1 : CX162

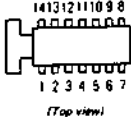

MB84013
34013PC

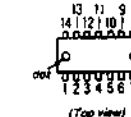

TC5081P

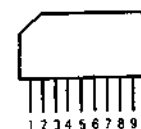

M54825P

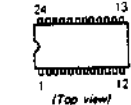

SN74LS290N
SN74S74N

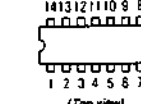

TA7060P



1T261
1T22AM
1T22AM
10E2
1S2139C
1S1555



2SC930-SP



VD1220

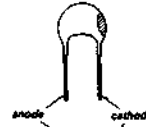

VD1120

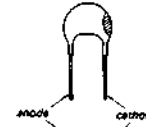

FC54E

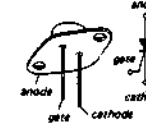

SEL103R

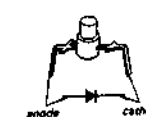

SL1512



AEP.UK.E MO

BATTERY TERMINAL
TO GROUND

For Service Manuals Contact
MAURITRON TECHNICAL SERVICES
8 Cherry Tree Rd, Chinnor
Oxon OX9 4QY
Tel:- 01844-351694 Fax:- 01844-352554
Email:- enquiries@mauritron.co.uk

4.1. MOUNTING DIAGRAM (1)

- Conductor Side -

1T261
1T22AM
1T22AM
10E2
1S2139C
1S1555



ZSC930-SP

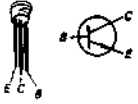

VD1220

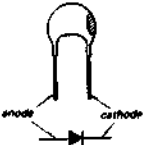

VD1120

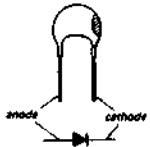

FC54E

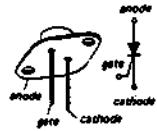

SEL103R

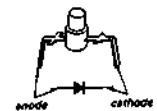

SL1512

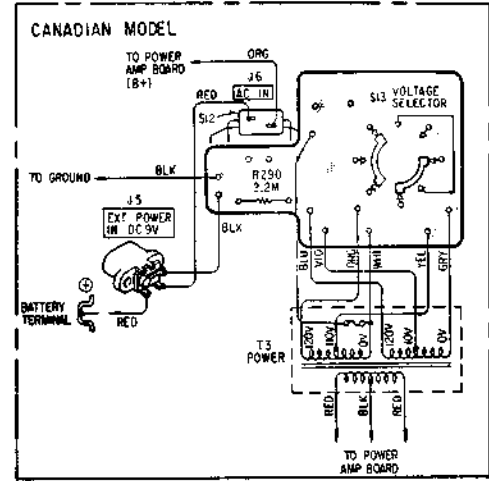
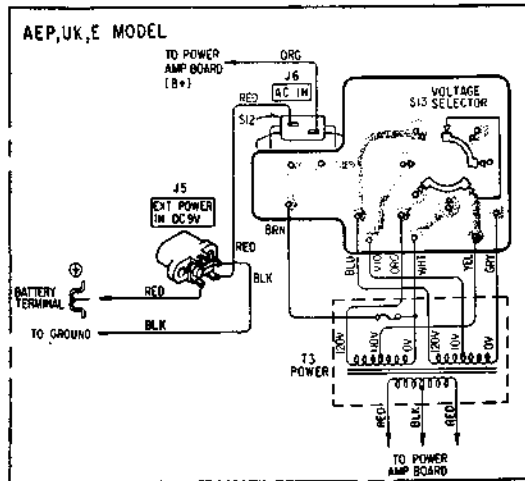
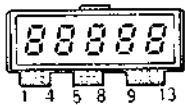

For Service Manuals Contact
MAURITRON TECHNICAL SERVICES
8 Cherry Tree Rd, Chinnor
Oxon OX9 4QY
Tel:- 01844-351694 Fax:- 01844-352554
Email:- enquiries@mauritron.co.uk

Note:

- ○ — : parts extracted from the component side.
- ● — : parts extracted from the conductor side.
- ■ — : part mounted on the conductor side.
- □ — : indicates side identified with part number.
- : B+ pattern

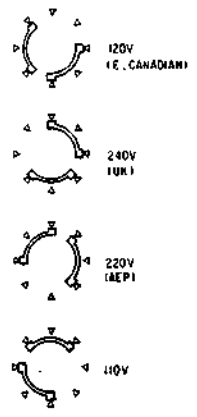
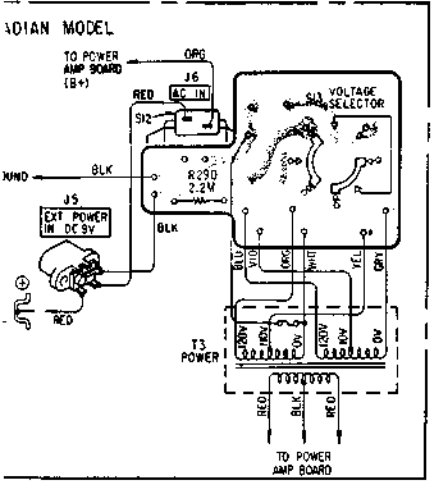

For Service Manuals Contact
MAURITRON TECHNICAL SERVICES
 8 Cherry Tree Rd. Chinnor
 Oxon OX9 4QY
 Tel: 01844-351894 Fax: 01844-352554
 Email: enquiries@mauratron.co.uk

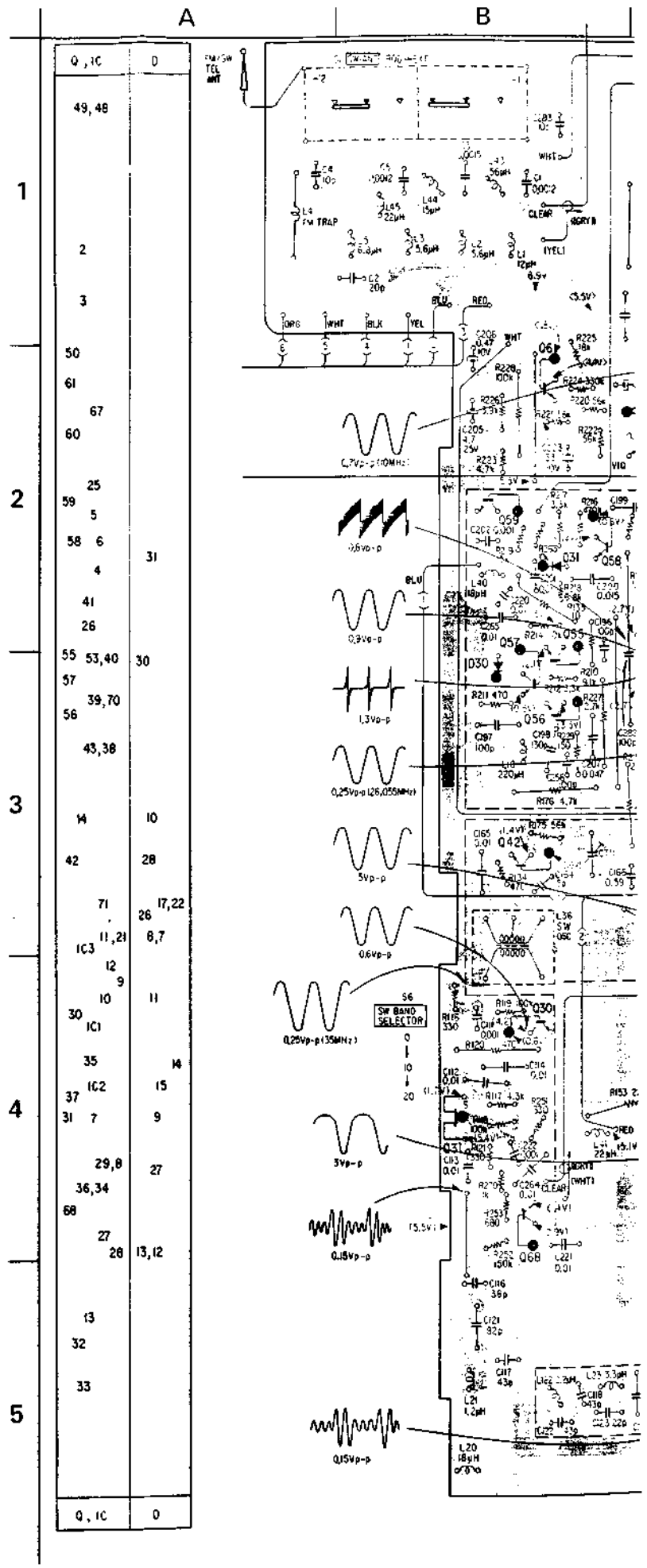

B

C

D

E

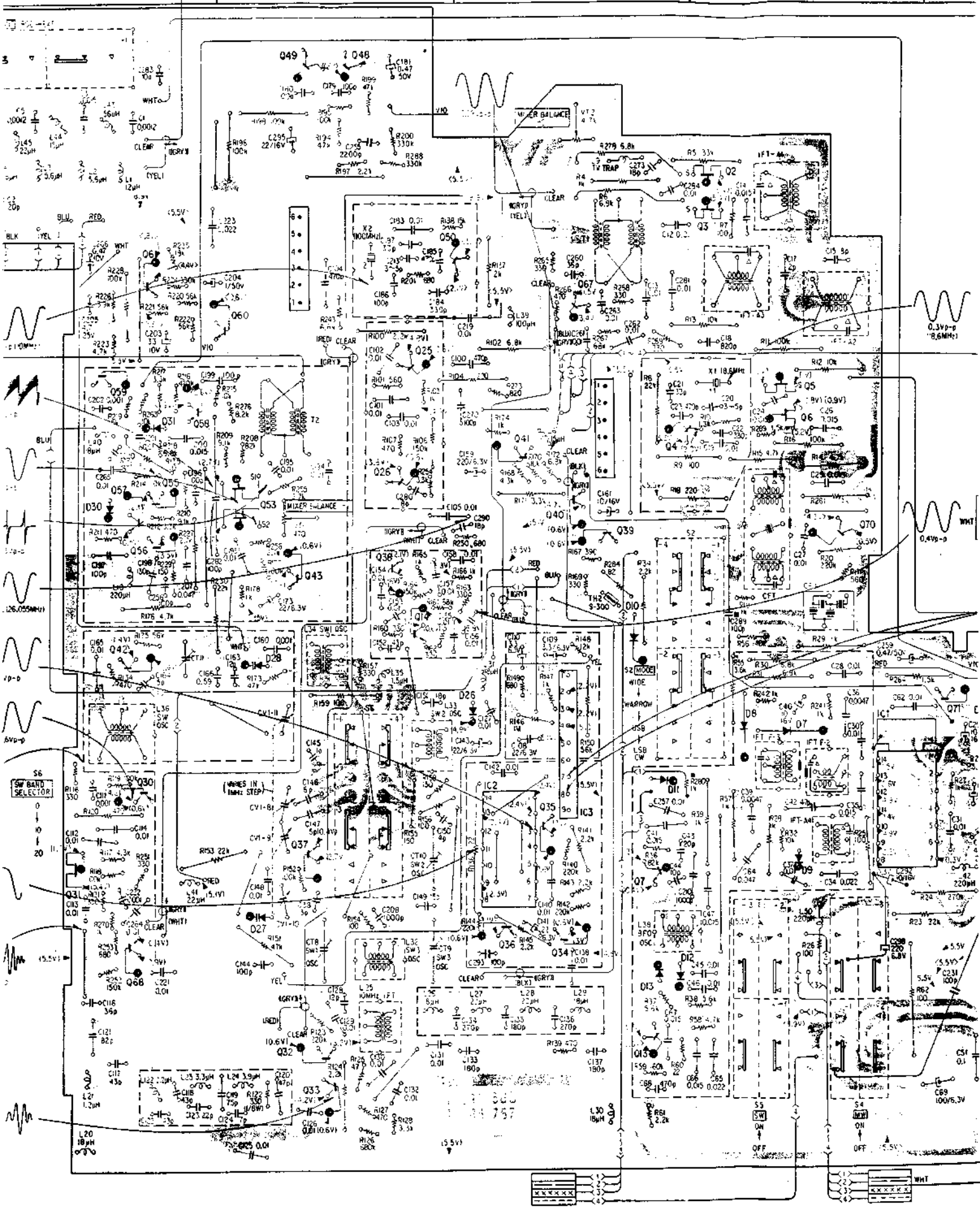

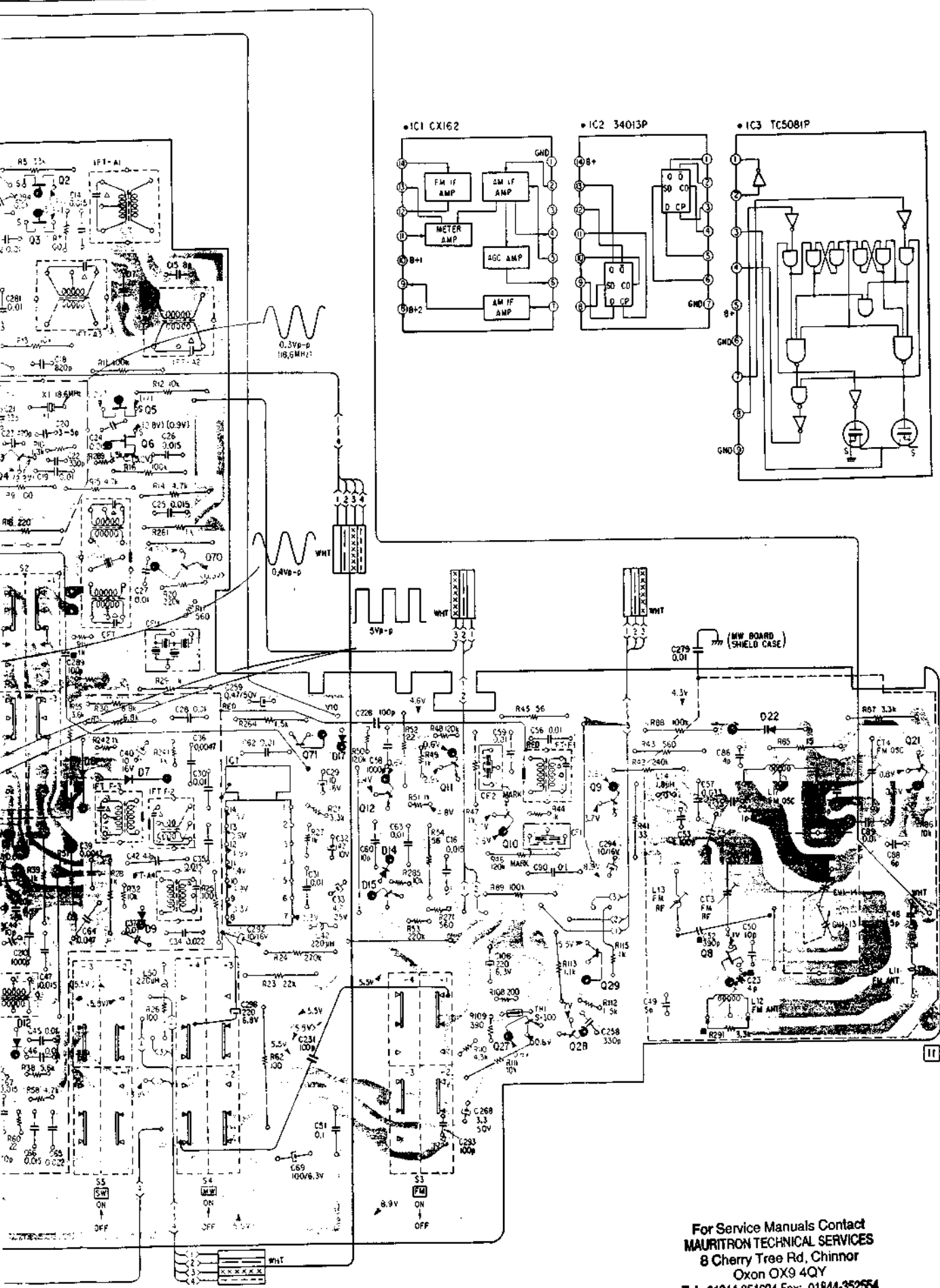

1
2
3
4
5

For Service Manuals Contact
MAURITRON TECHNICAL SERVICES
 8 Cherry Tree Rd, Chinnor
 Oxon OX9 4QY
 Tel: 01844-351694 Fax: 01844-352554
 Email: enquiries@mauritron.co.uk

Semiconductor Leads Layout: See page 49

B

C

D

[BATTERY BOX]

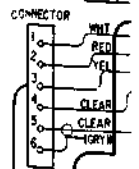
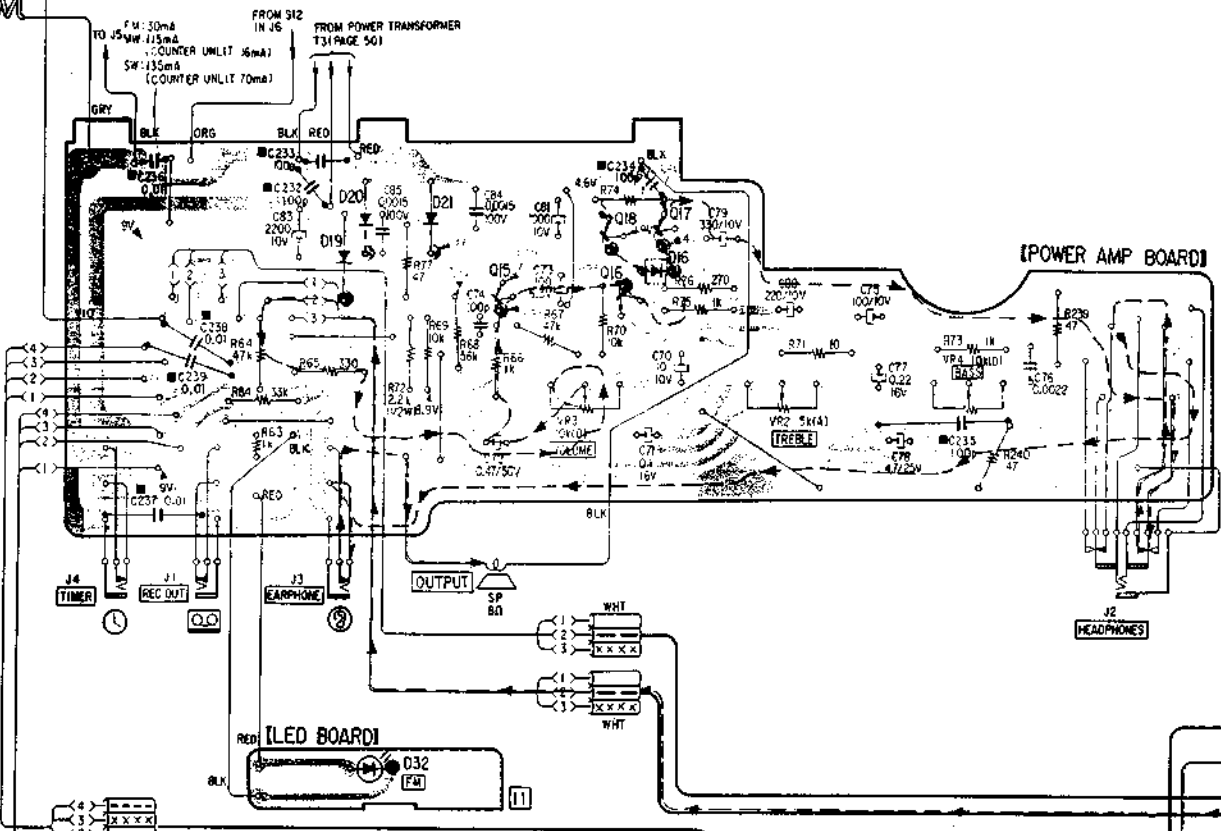
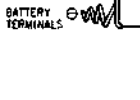

[POWER AMP BOARD]

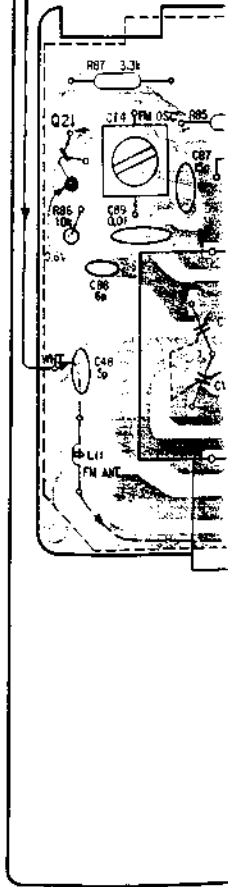
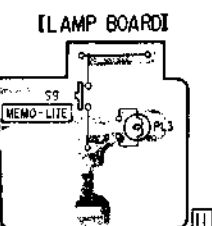
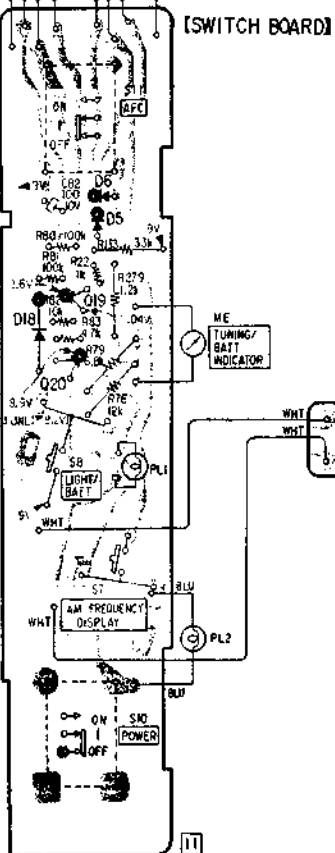
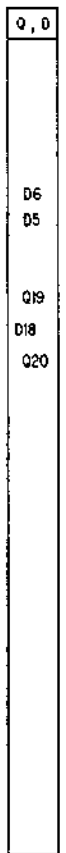
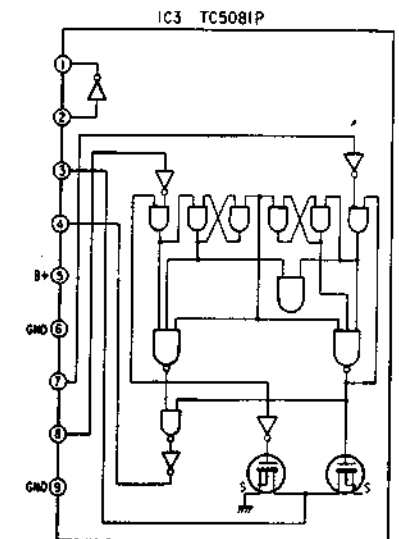
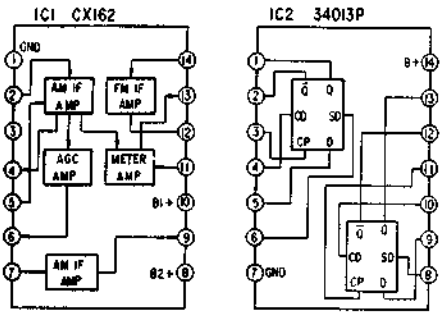

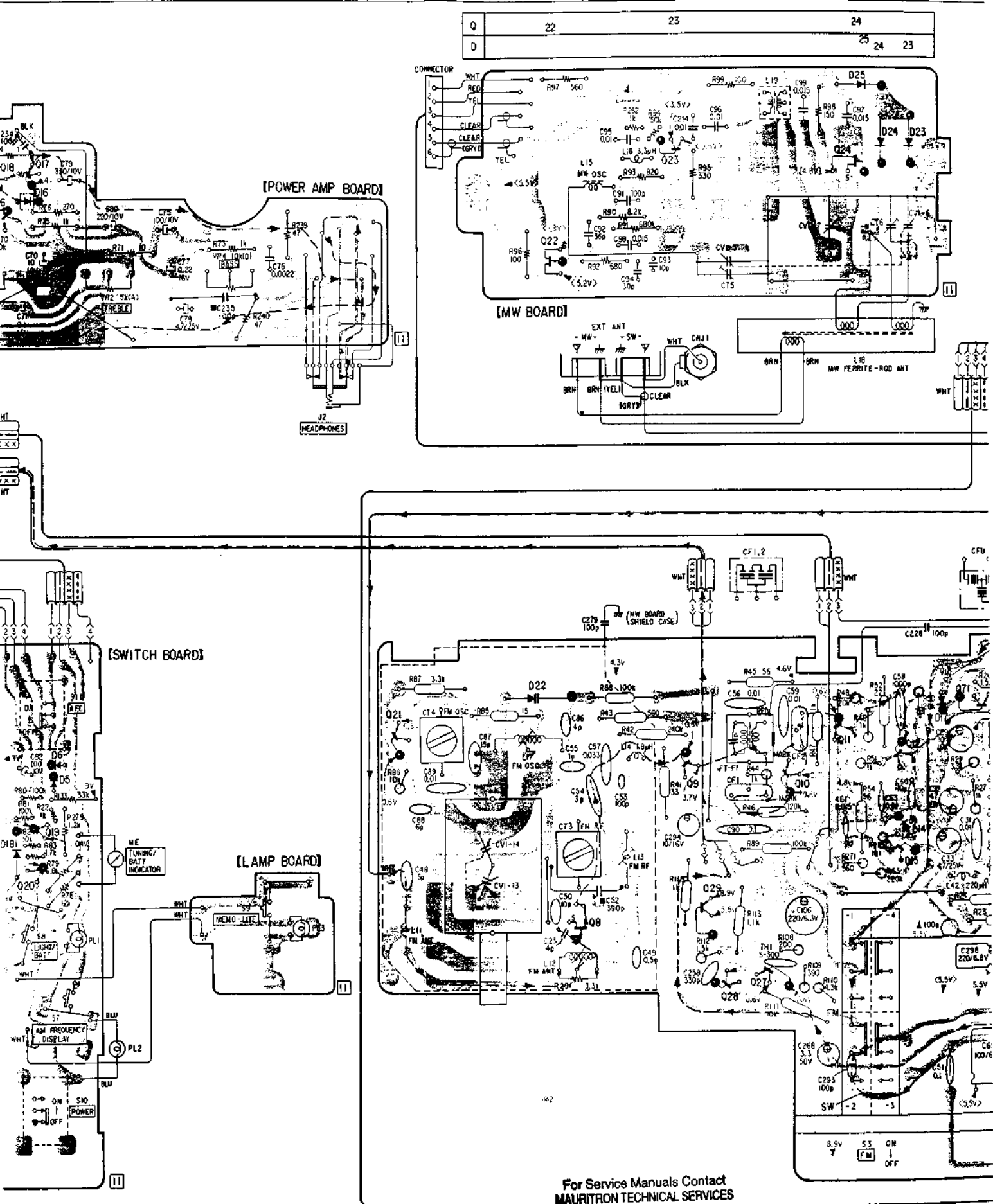

For Service Manuals Contact
MAURITRON TECHNICAL SERVICES
 8 Cherry Tree Rd, Chinnor
 Oxon OX9 4QY
 Tel: 01844-351894 Fax: 01844-352554
 Email: enquiries@mauritron.co.uk

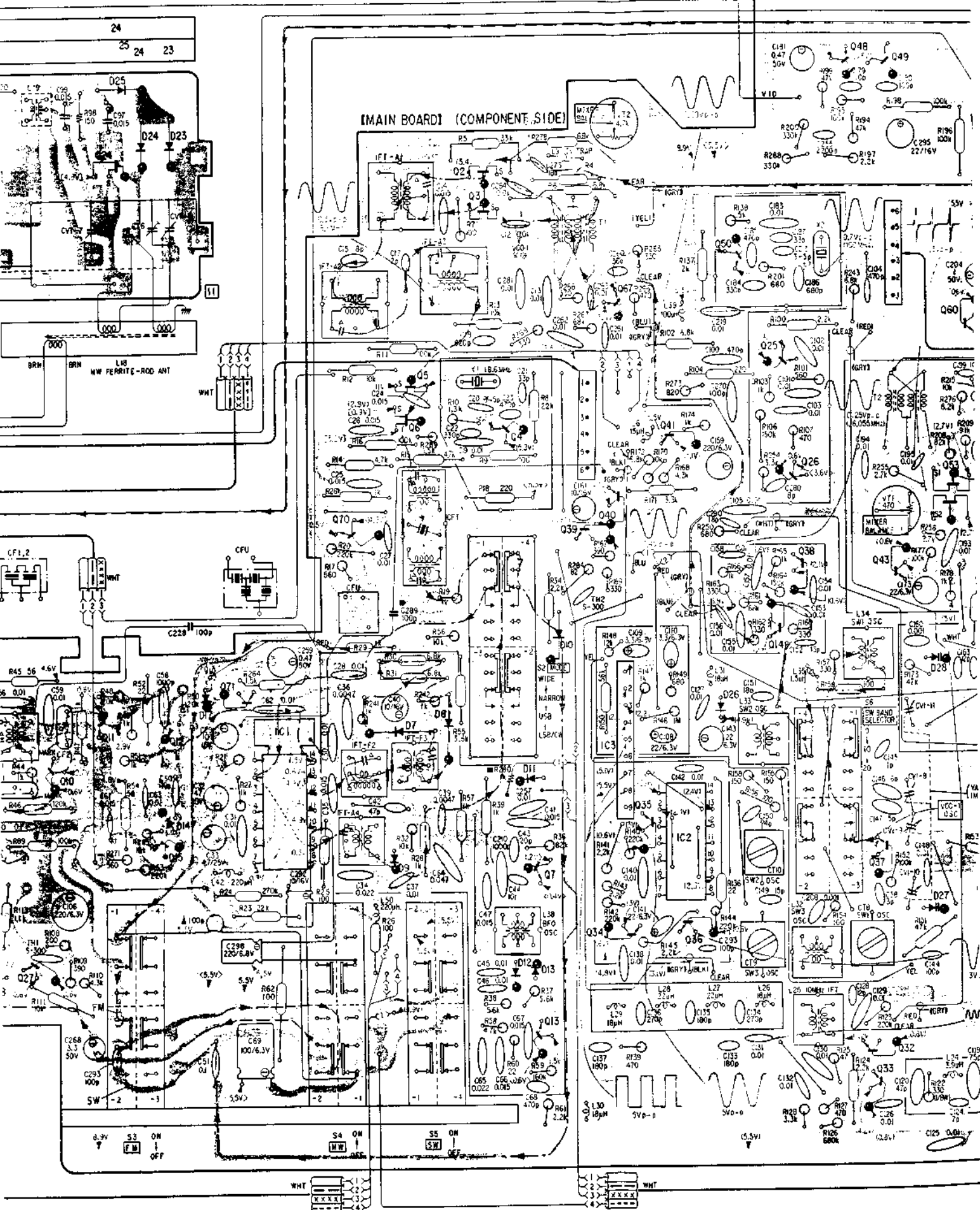

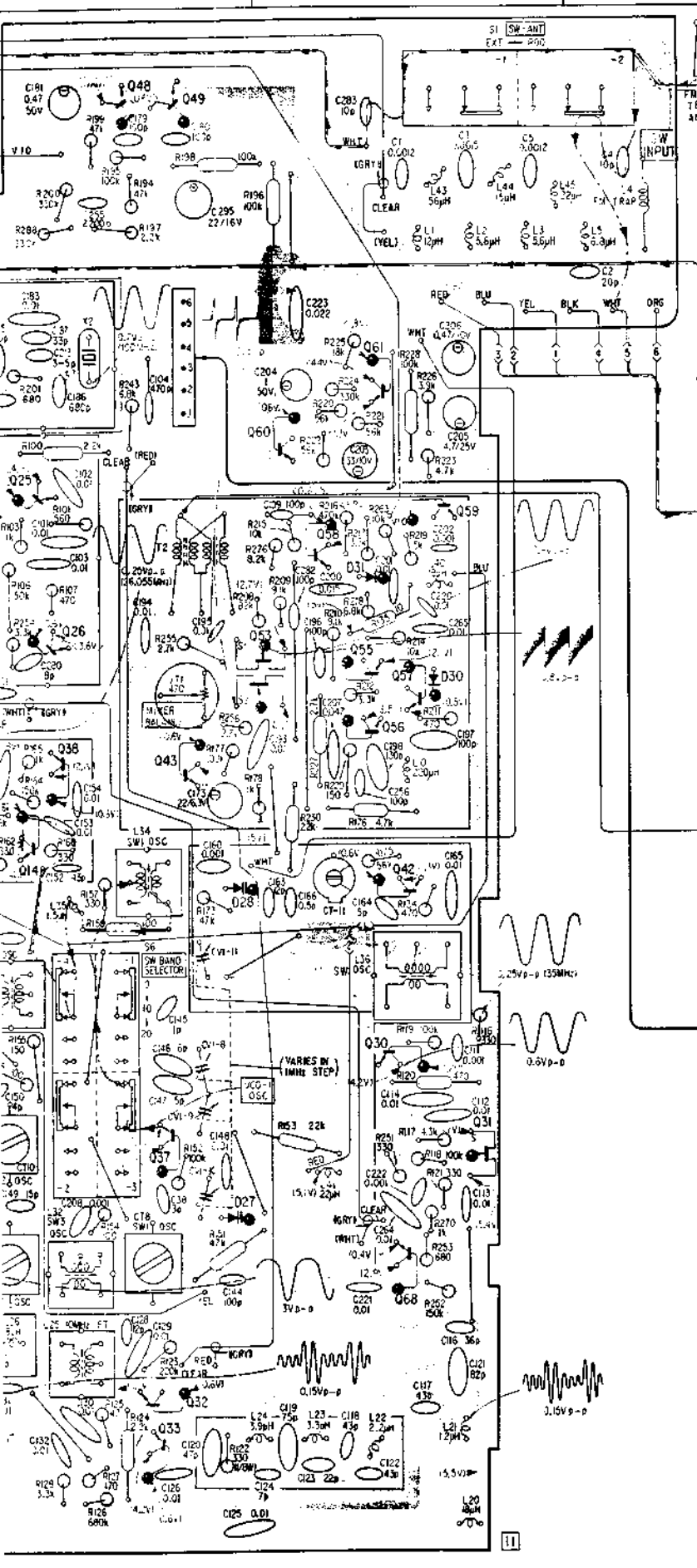

Q, IC	D
FM INPUT	48,49
2	
3	
50	61
67	60
25	59
5	
6	58
4	41
26	
40,53	55
70,39	57
38	56
43	
14	
42	
22	28
17	
26	8
7	
9	10
11	
12	IC3
10	
IC1	30
35	
IC2	37
7	31
29	
8	36
34	68
27	
28	13
13	
32	
33	
Q, IC	D

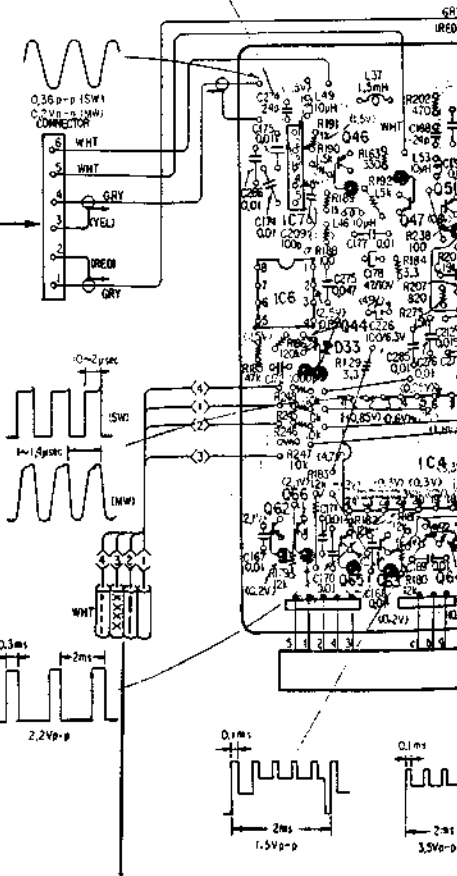
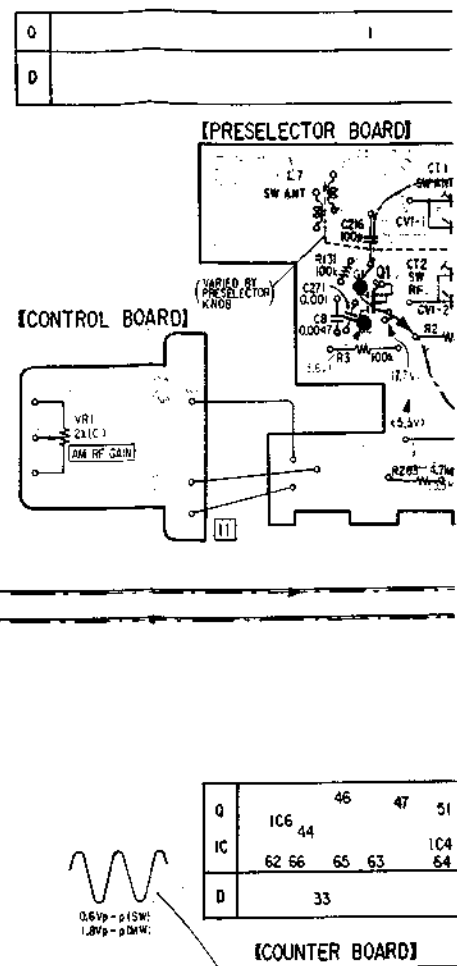

For Service Manuals Contact
MAURITRON TECHNICAL SERVICES
 8 Cherry Tree Rd, Chinnor
 Oxon OX9 4QY
 Tel: 01844-351694 Fax: 01844-352554
 Email: enquiries@mauritron.co.uk

1 72

1 2 3
4

[PRESELECTOR BOARD]

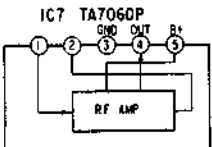
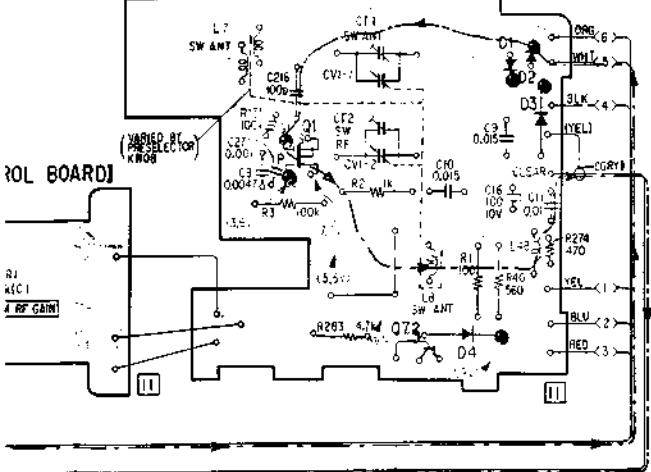

ROL BOARD]

Q	46	47	51	IC8			
IC	44	62	66	65	63	IC4	64
D	33	29					

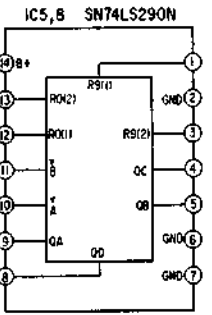

[COUNTER BOARD]

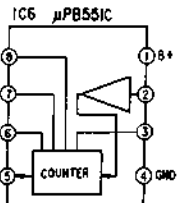
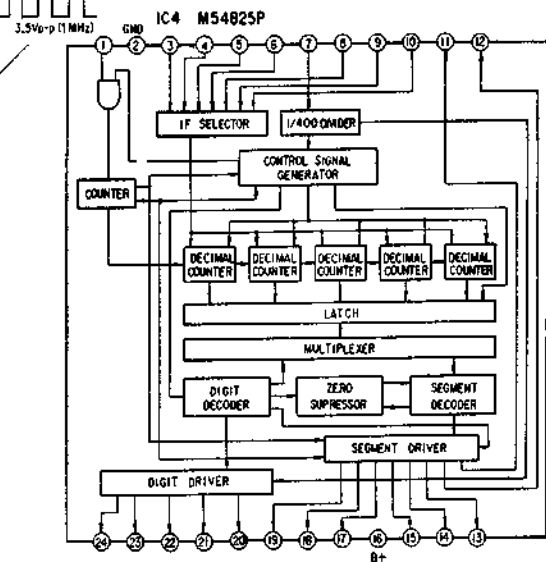
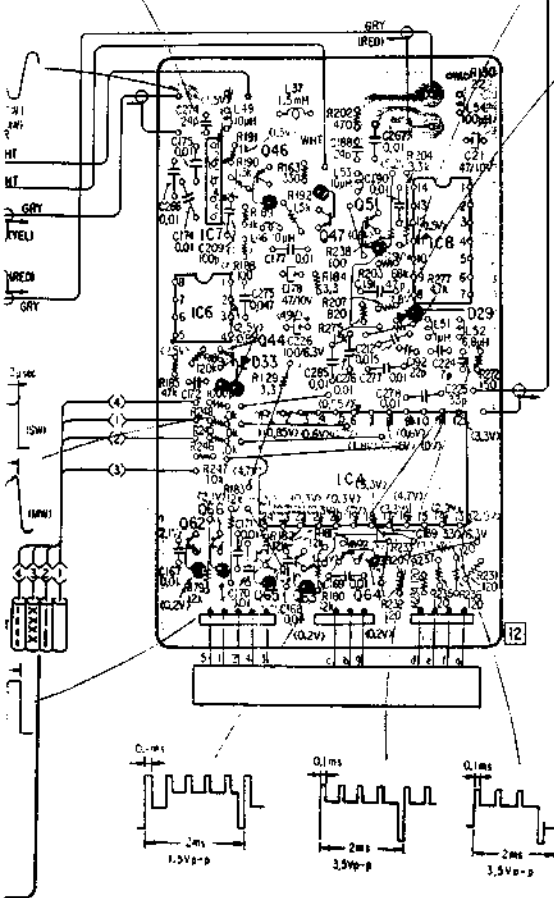

- Note:
- — : parts extracted from the component side.
 - — : parts extracted from the conductor side.
 - ◆ — : part mounted on the conductor side.
 - — : indicates side identified with part number.
 - — : B+ pattern
 - : signal path
 - : FM
 - : SW

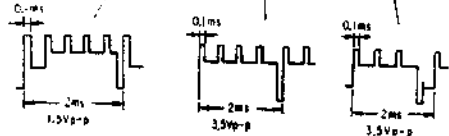

A B C D

Q IC	8	21	9	10	11	12	3	41	IC1
	50	42 37	43 72	30 31	68	14	38	32 39 53	40 33

[MAIN BOARD]

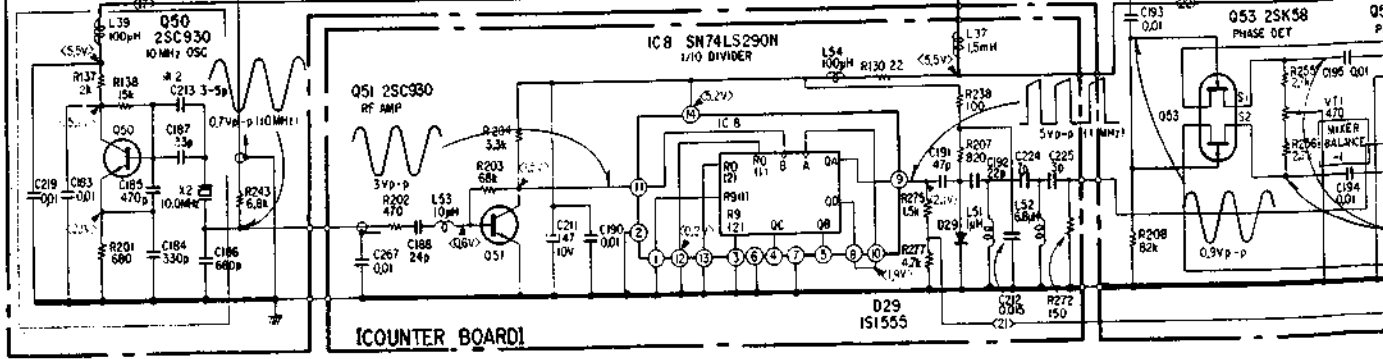
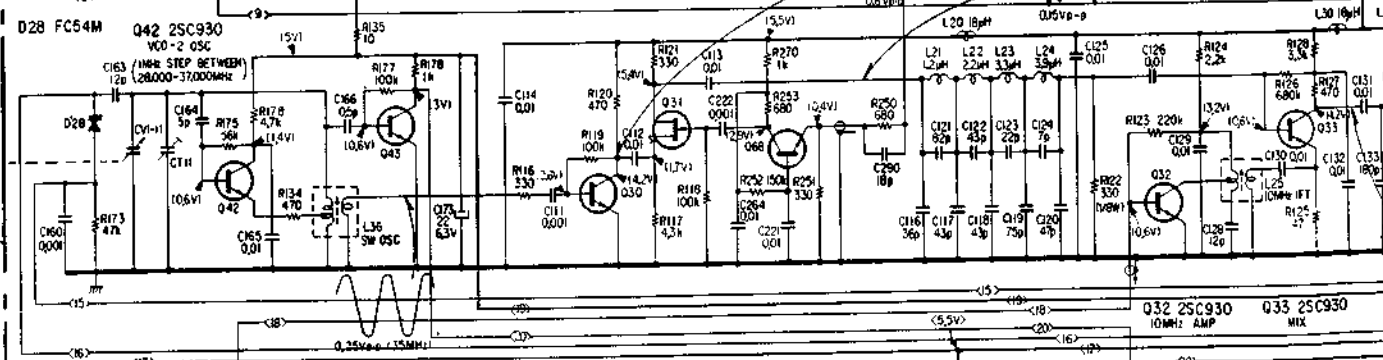
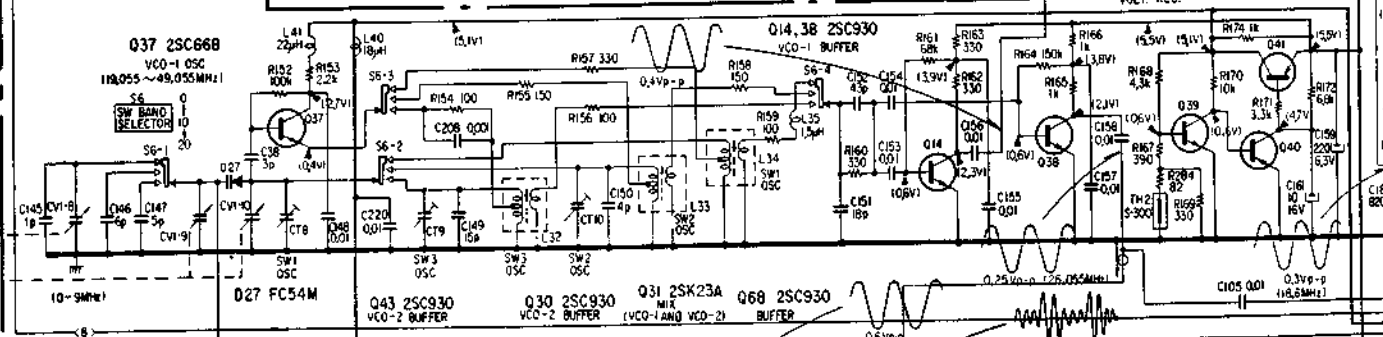
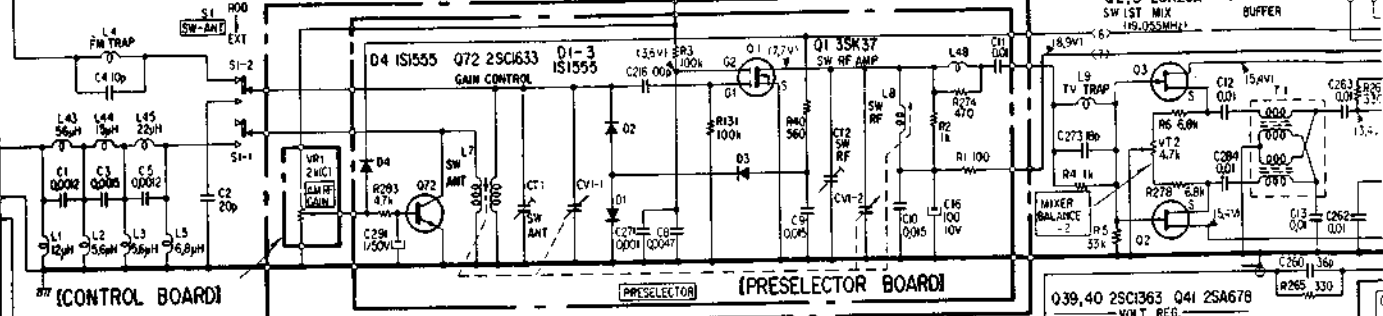
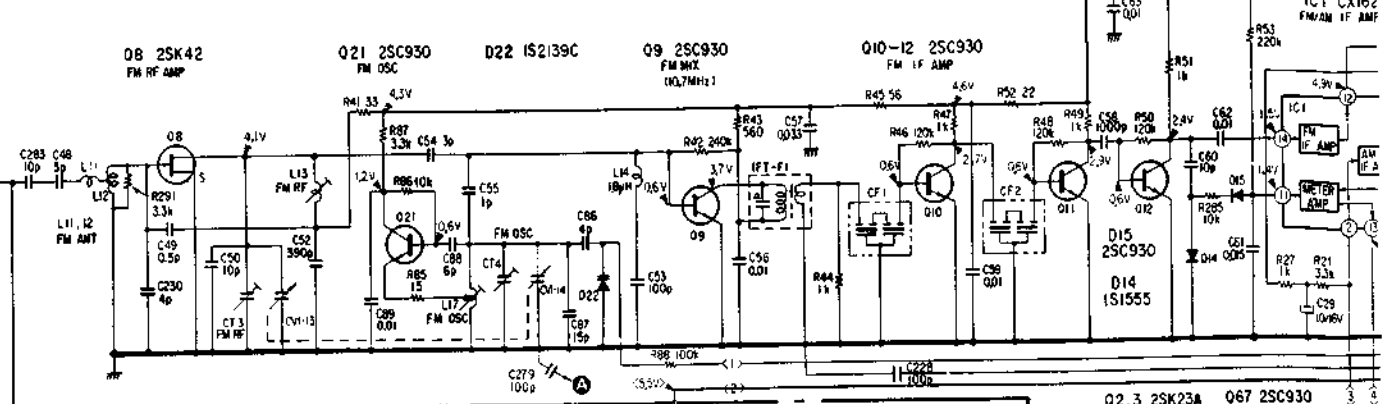

For Service Manuals Contact
MAURITRON TECHNICAL SERVICES
8 Cherry Tree Rd, Chinnor
Oxon OX9 4QY
Tel: 01844-351694 Fax: 01844-352554
Email: enquiries@maurtron.co.uk

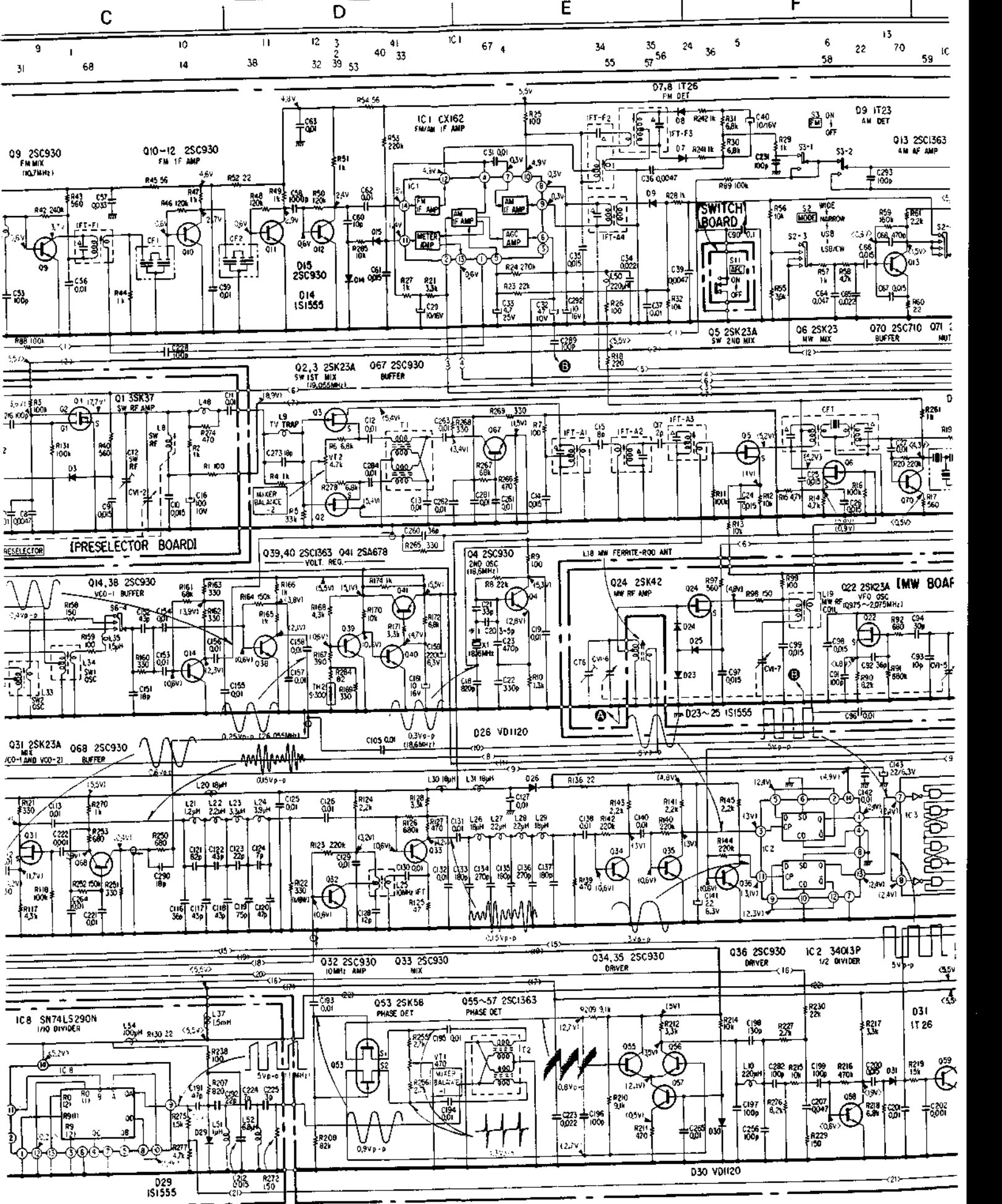

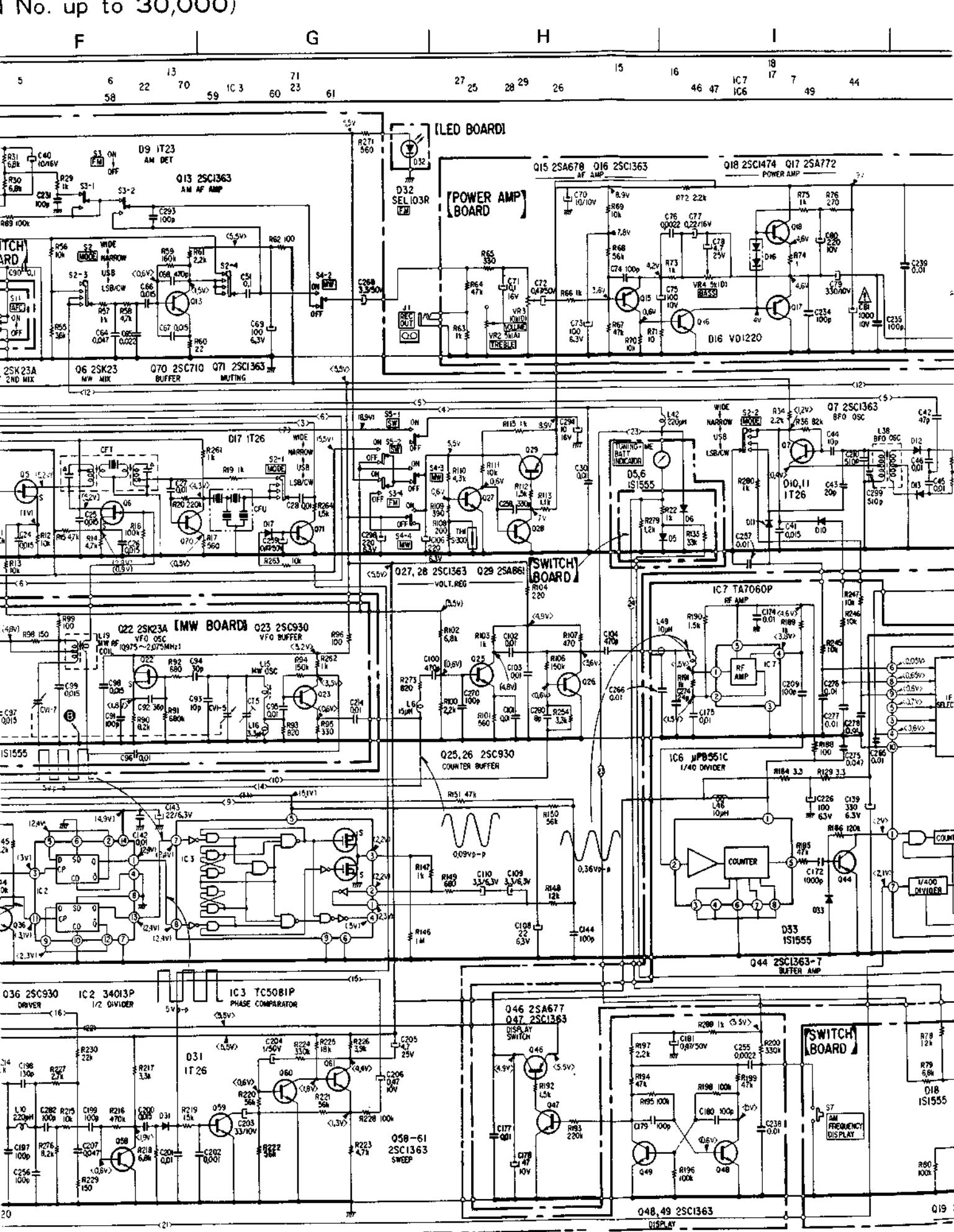



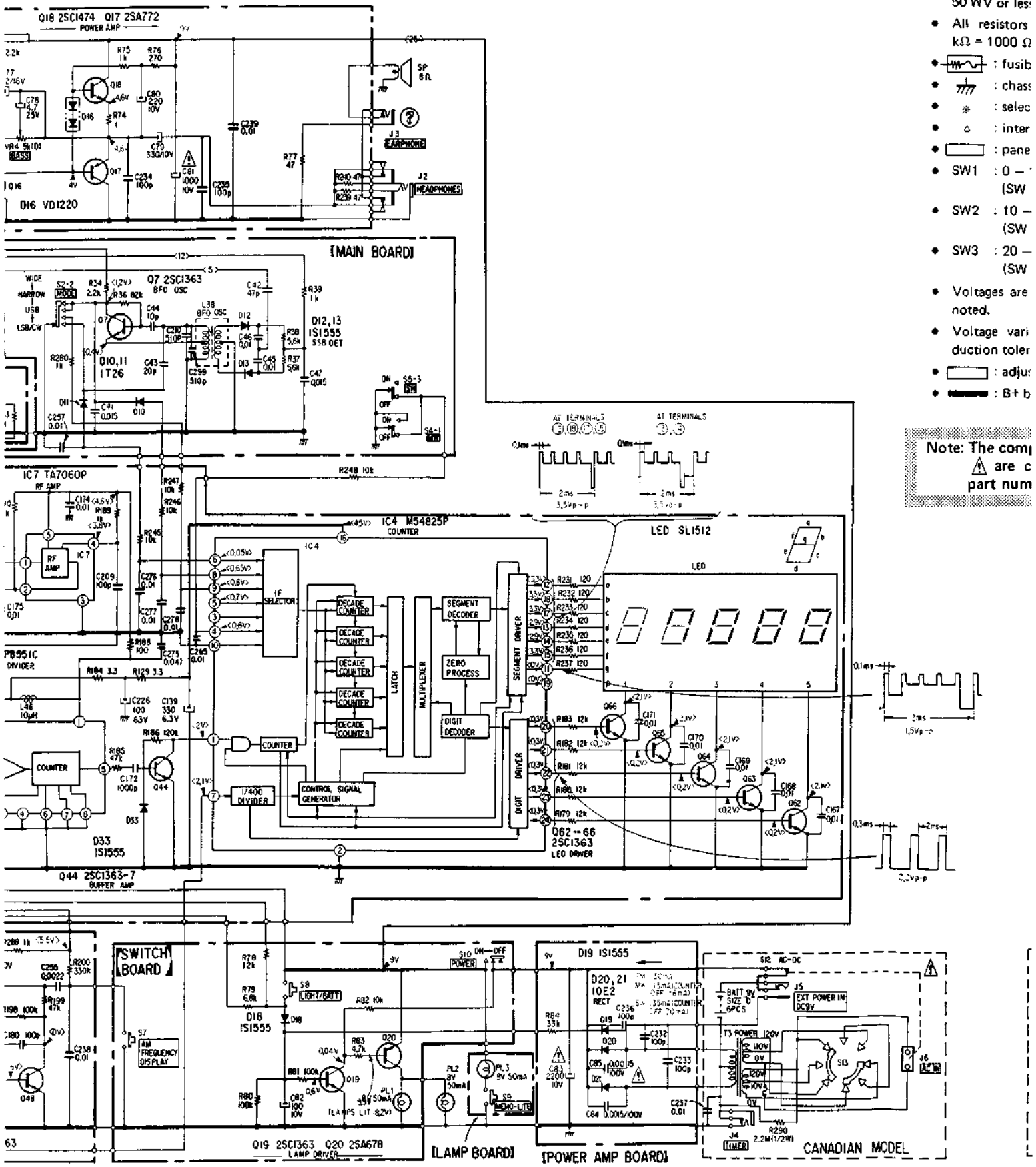

For Service Manuals Contact
MAURITRON TECHNICAL SERVICES
 9 Cherry Tree Rd, Chinnor
 Oxon OX9 4QY
 Tel: 01844-351694 Fax: 01844-352554
 Email: enquiries@mauritron.co.uk



2

Note:

- All capacitors are in μF unless otherwise noted. $\text{pF} = \mu\mu\text{F}$
50 WV or less are not indicated except for electrolytics.
- All resistors are in ohms, $\frac{1}{4}\text{W}$ unless otherwise noted.
 $\text{k}\Omega = 1000 \Omega$, $\text{M}\Omega = 1000 \text{k}\Omega$
-  : fusible resistor.
-  : chassis ground.
- * : selected to yield optimum performance.
- Δ : internal component.
-  : panel designation.
- SW1 : 0 – 10 MHz
(SW BAND SELECTOR in "0")
- SW2 : 10 – 20 MHz
(SW BAND SELECTOR in "10")
- SW3 : 20 – 30 MHz
(SW BAND SELECTOR in "20")
- Voltages are dc with respect to ground unless otherwise noted.
- Voltage variations may be noted due to normal production tolerances.
-  : adjustment for repair.
-  : B+ bus.

- Readings are taken under no-signal (detuned) conditions with a VOM (20 $\text{k}\Omega/\text{V}$).
() : SW
[] : MW
< > : AM (MW and SW)
no mark : FM
- Switch

Ref. No.	Switch	Position
S1	SW-ANT	ROD
S2	MODE	WIDE
S3	FM	ON
S4	MW	OFF
S5	SW	OFF
S6	SW BAND SELECTOR	O
S7	AM FREQUENCY DISPLAY	OFF
S8	LIGHT/BATT	OFF
S9	MEMO-LITE	OFF
S10	POWER	OFF
S11	AFC	OFF
S12	AC/DC	DC

Note: The components identified by shading and mark Δ are critical for safety. Replace only with part number specified.

Note: Les composants identifiés par un trame et une marque Δ sont critiques pour la sécurité. Ne les remplacer que par une pièce portant le numéro spécifié.

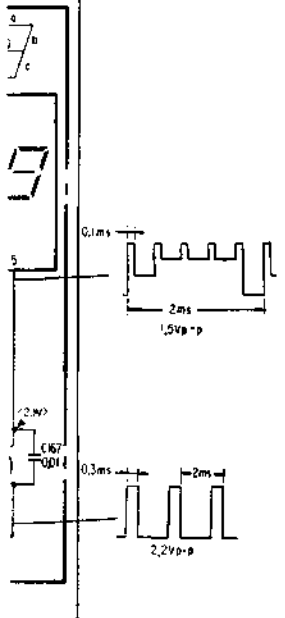

For Service Manuals Contact
MAURITRON TECHNICAL SERVICES
 8 Cherry Tree Rd, Chinnor
 Oxon OX9 4QY
 Tel: 01844-351694 Fax: 01844-352554
 Email: enquires@mauritron.co.uk

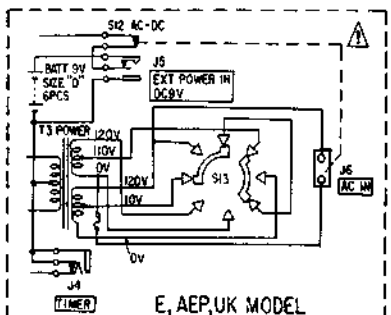
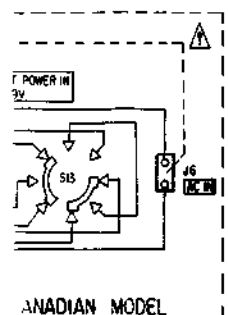

4-4. MOUNTING DIAGRAM

(Serial No. 30,001 and later)

Semiconductor Leads Layout: See Page 49

1
2
3
4
5

B C D

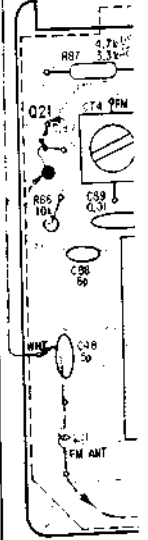
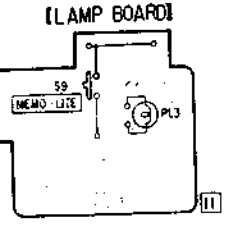
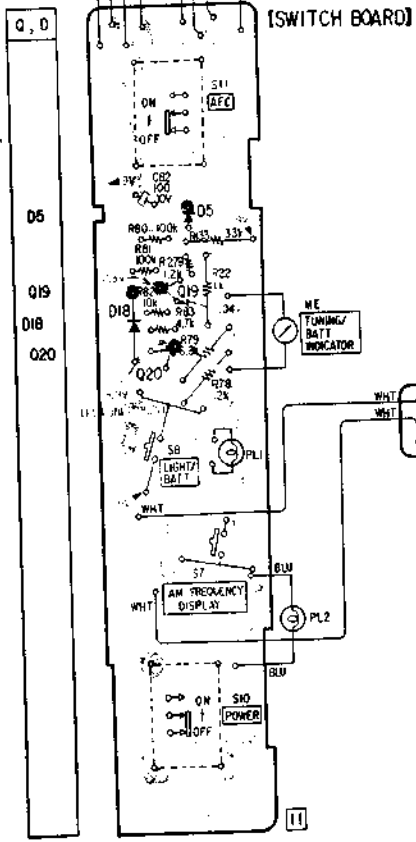
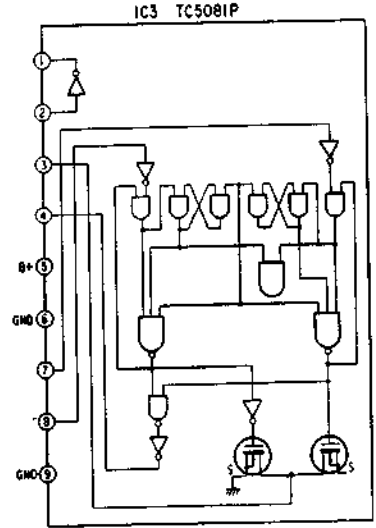
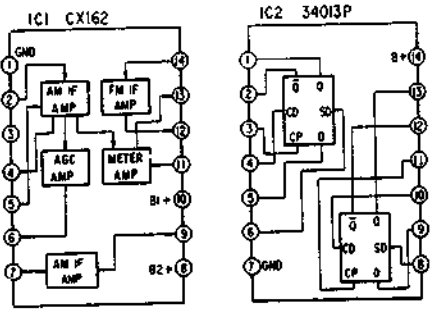
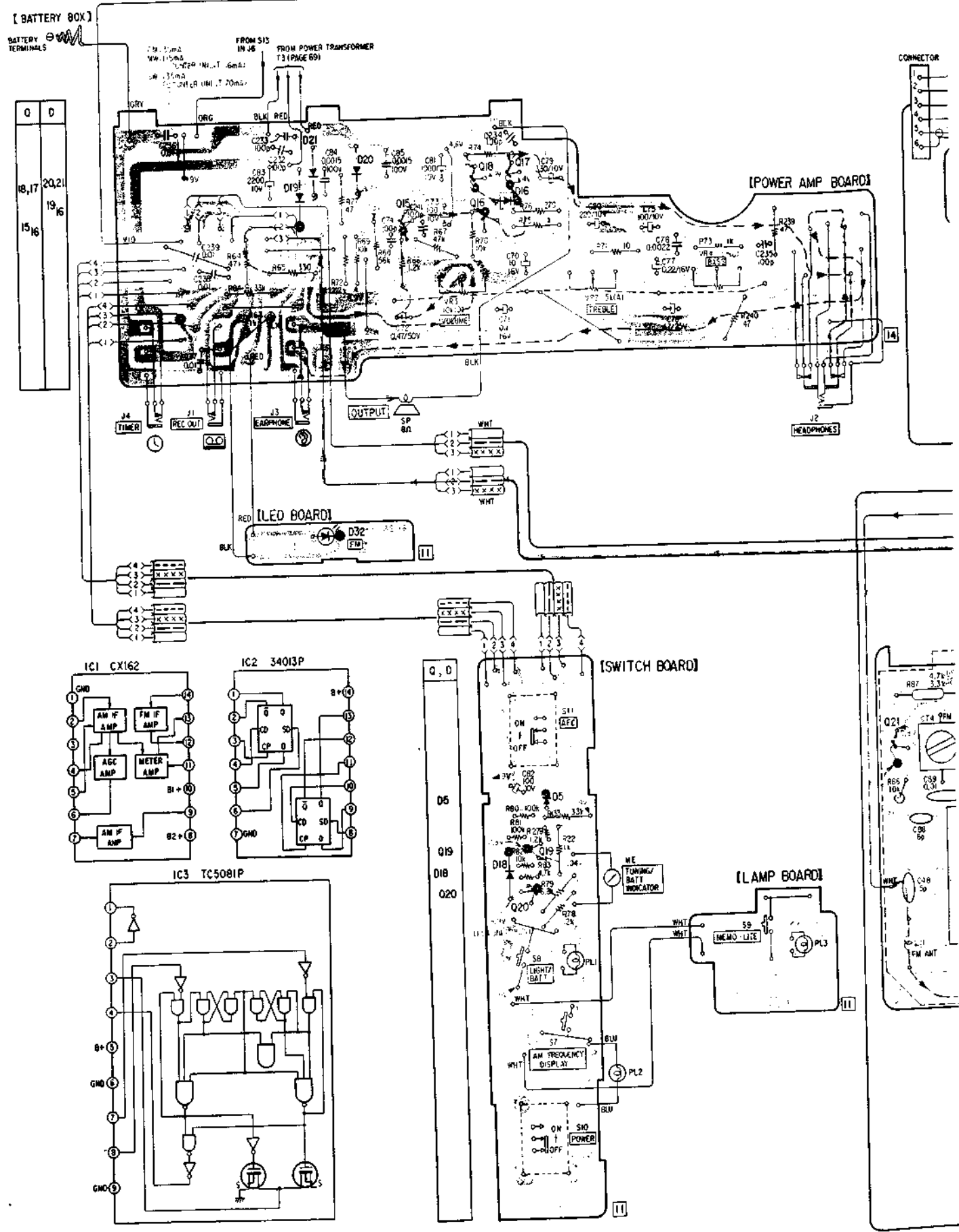

C D E F

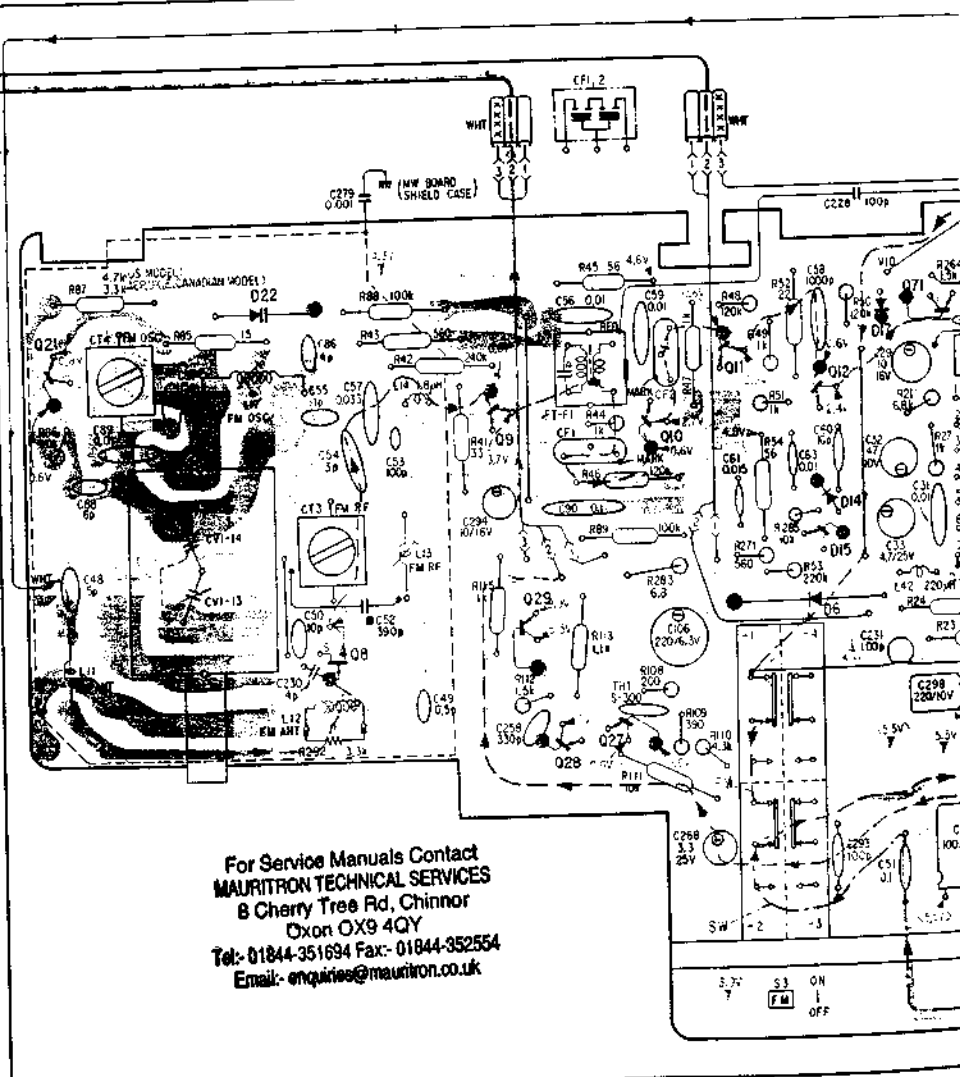
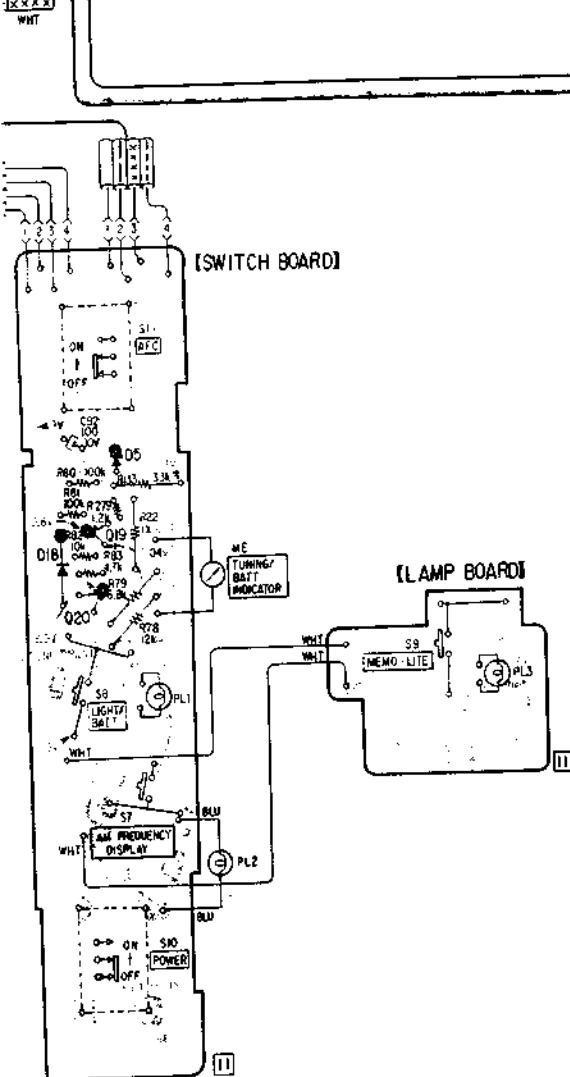
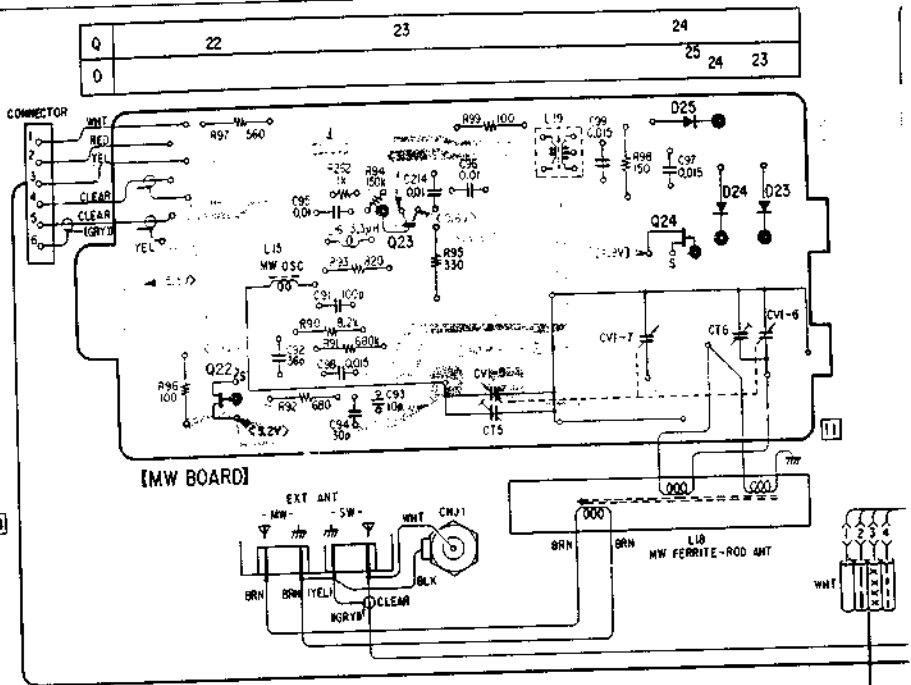
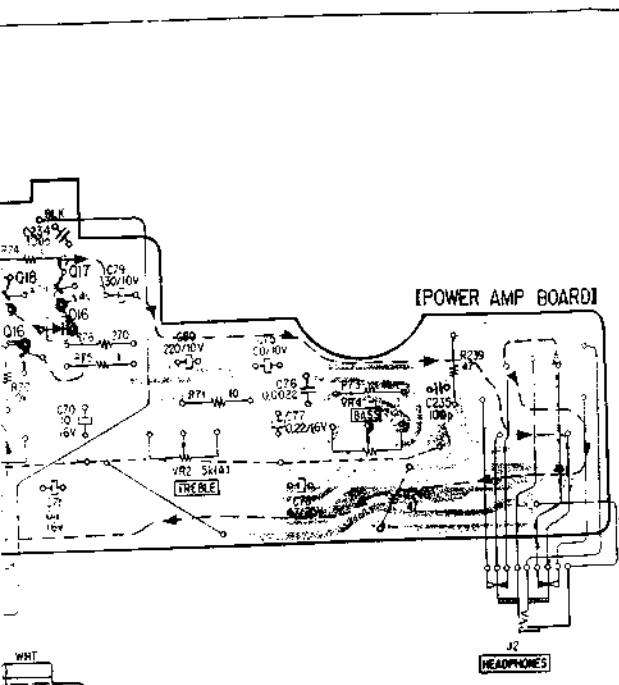

For Service Manuals Contact
MAURITRON TECHNICAL SERVICES
 8 Cherry Tree Rd, Chinnor
 Oxon OX9 4QY
 Tel: 01844-351694 Fax: 01844-352554
 Email: enquiries@mauritron.co.uk

F

G

H

I

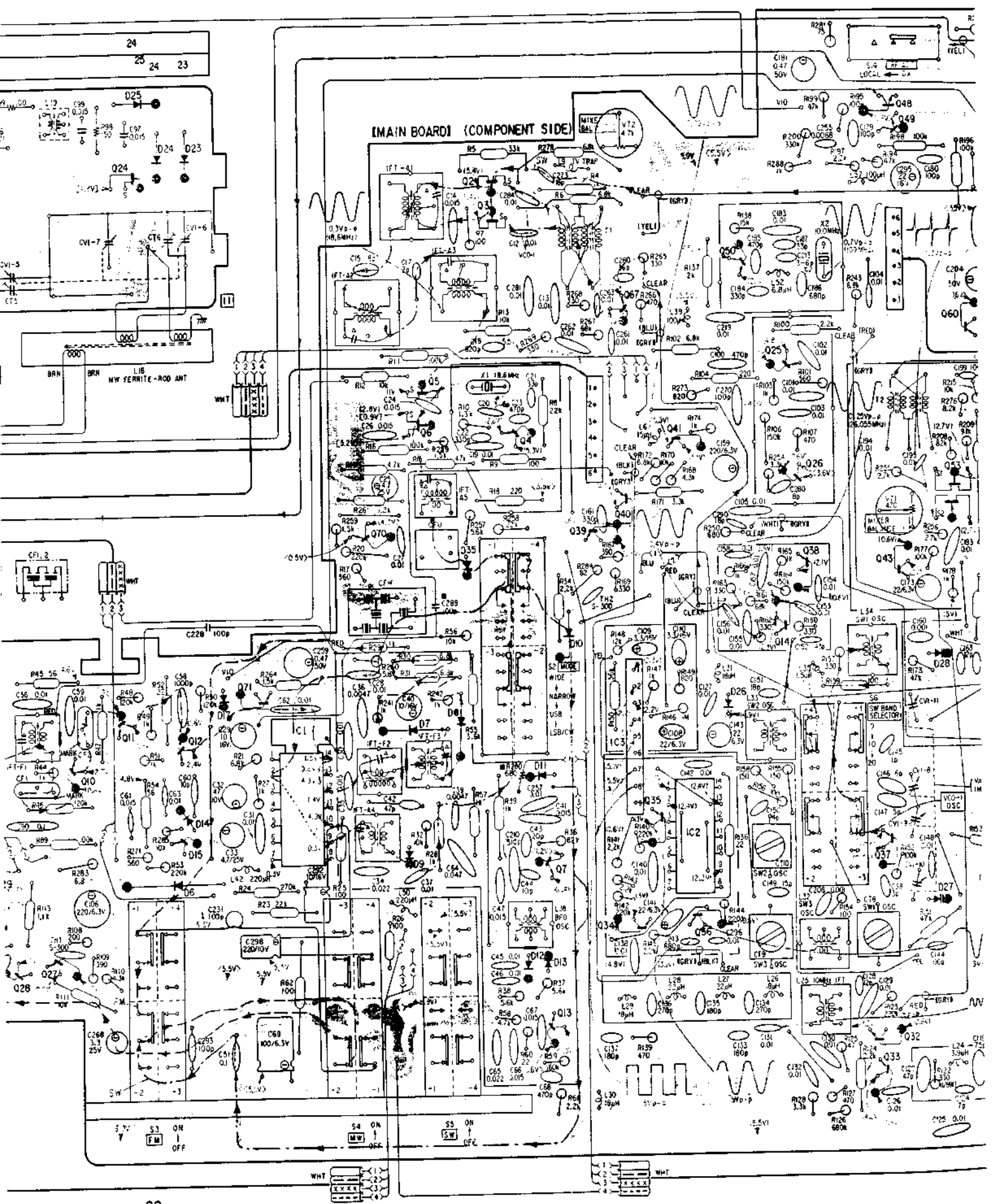

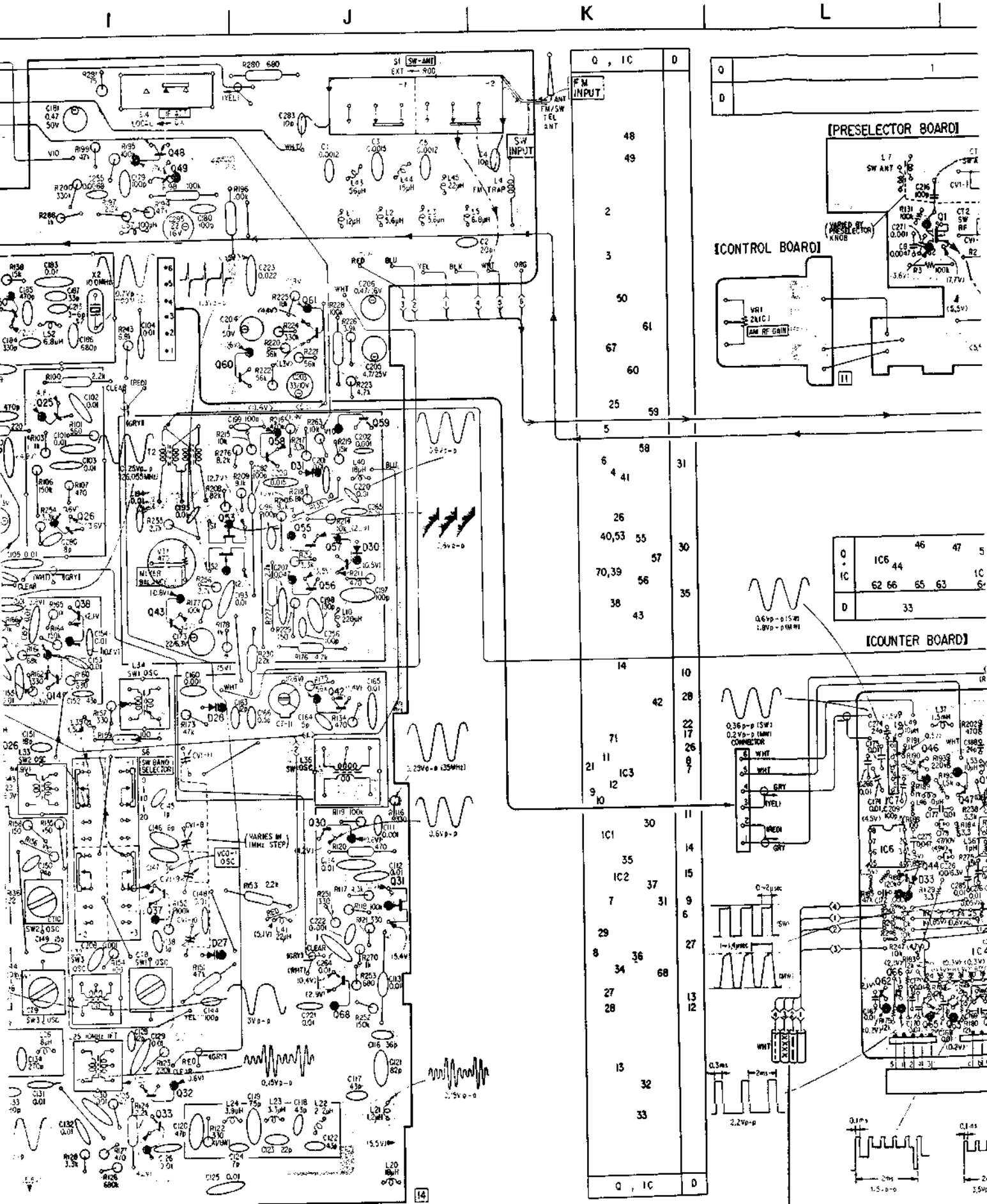

For Service Manuals Contact
MAURITRON TECHNICAL SERVICES
 8 Cherry Tree Rd, Chinnor
 Oxon OX9 4QY
 Tel: 01844-351694 Fax: 01844-352554
 Email: enquiries@mauritron.co.uk

L M N O

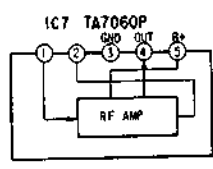
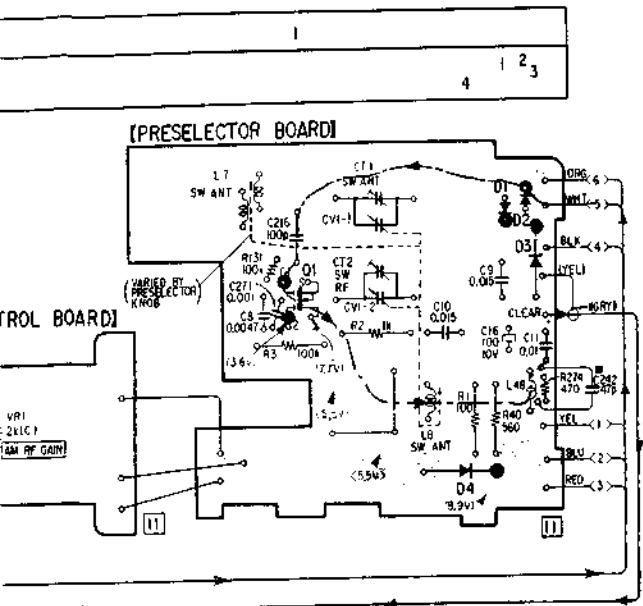

0	46	47	51	ICB
•	IC6 44		51	
IC	62 66	65 63	IC4	64
D	33		29	

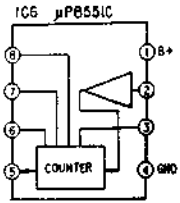
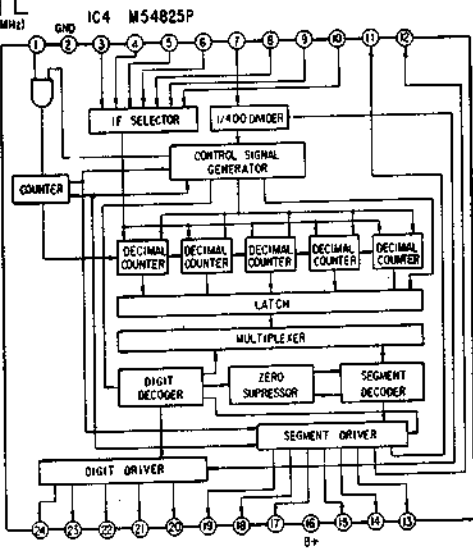
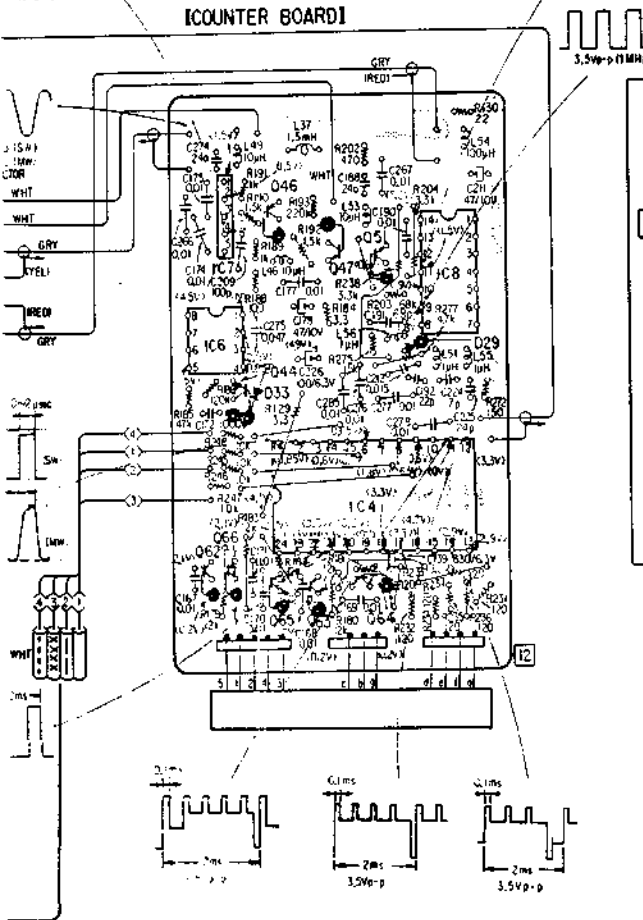
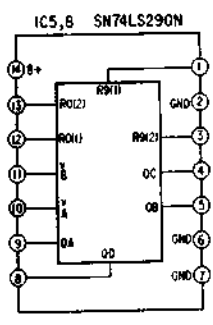

- Note:**
- ○ — : parts extracted from the component side.
 - ● — : parts extracted from the conductor side.
 - ■ — : part mounted on the conductor side.
 - □ — : indicates side identified with part number.
 - — : B+ pattern
 - — : signal path
 - — : L-CH signal path
 - — : R-CH signal path

4.5. SCHEMATIC DIAGRAM
(Serial No. 30,001 and later)

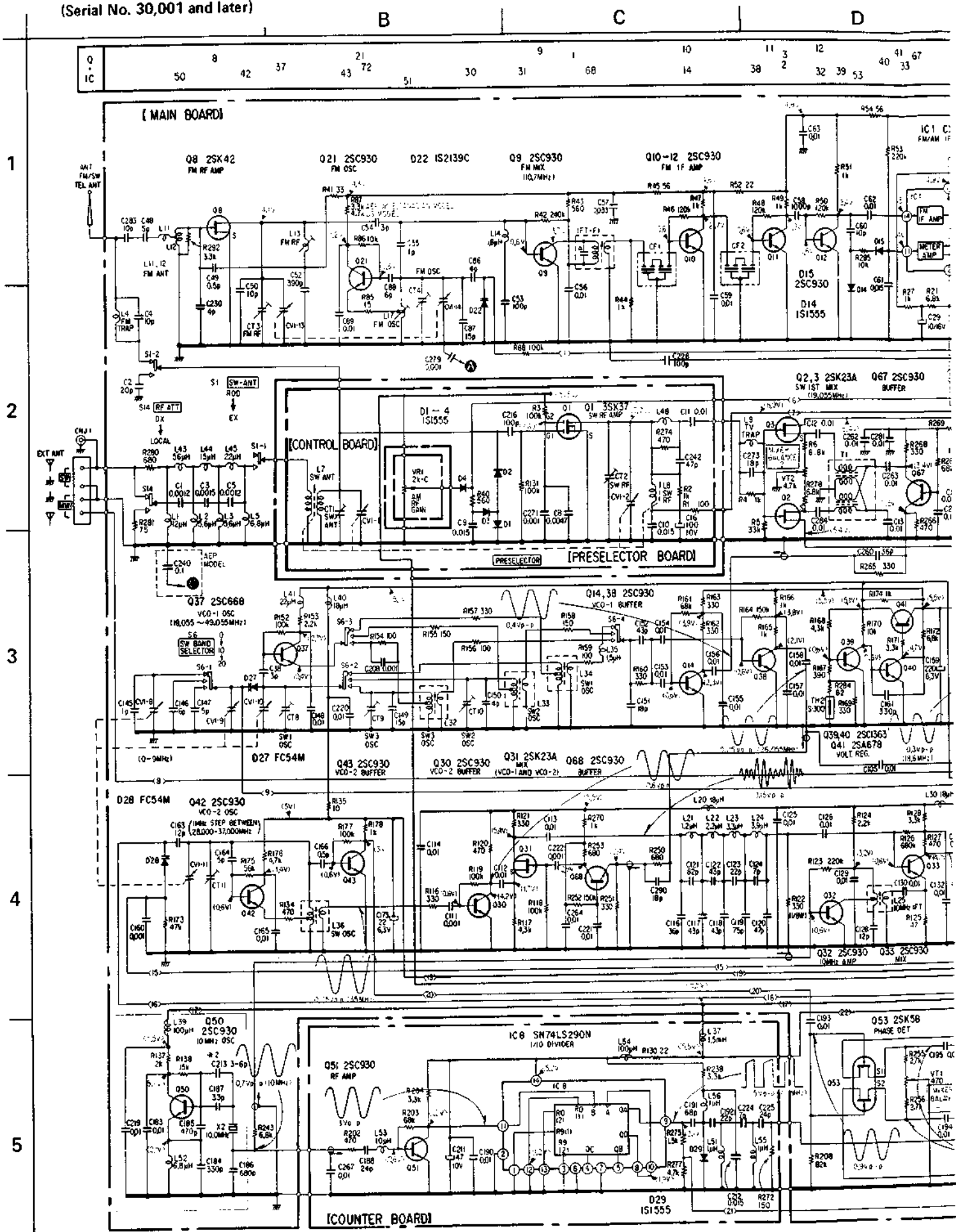

For Service Manuals Contact
MAURITRON TECHNICAL SERVICES
 8 Cherry Tree Rd, Chinnor
 Oxon OX9 4QY
 Tel: 01844-351694 Fax: 01844-352554
 Email: enquiries@maurtron.co.uk

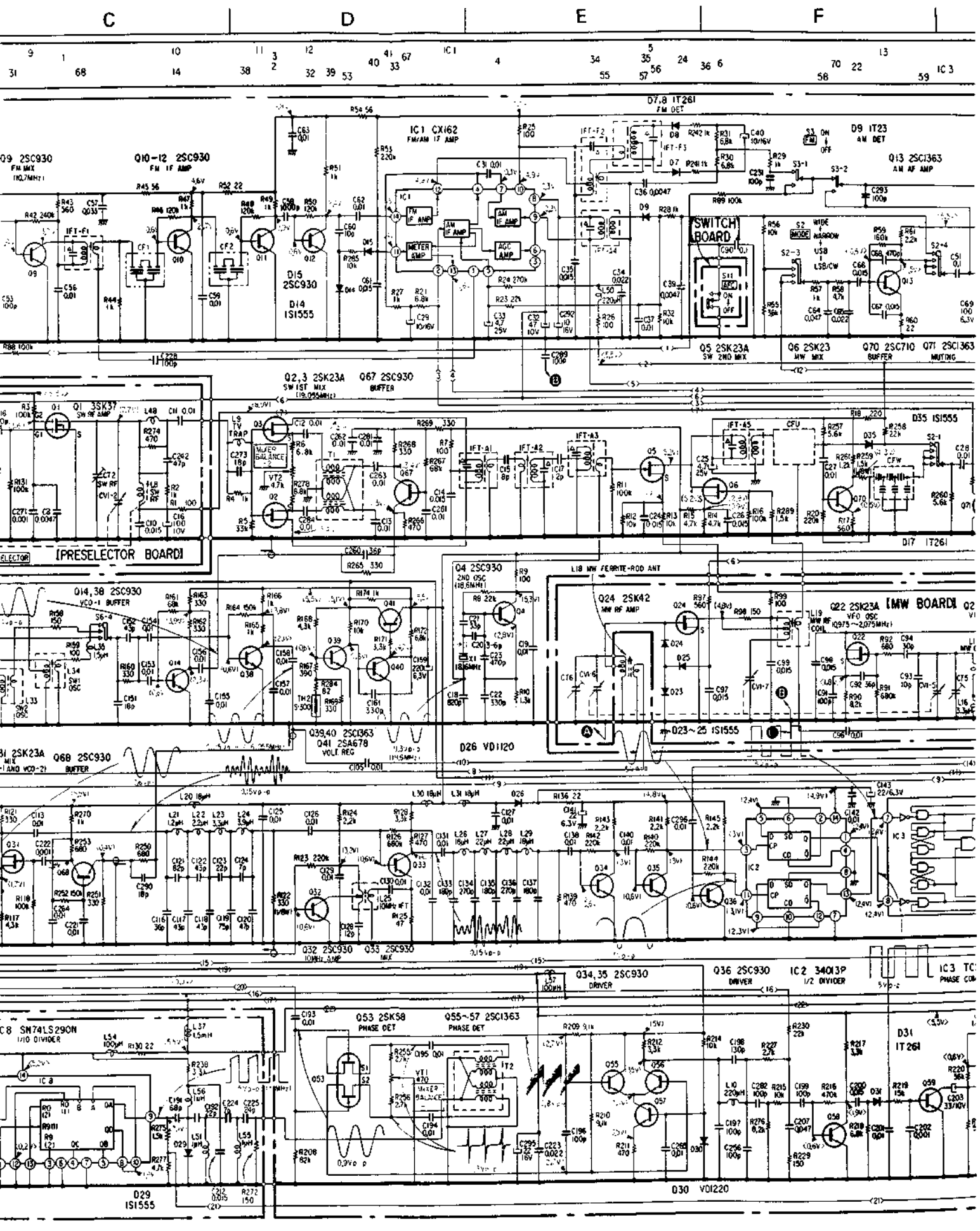

F

G

H

I

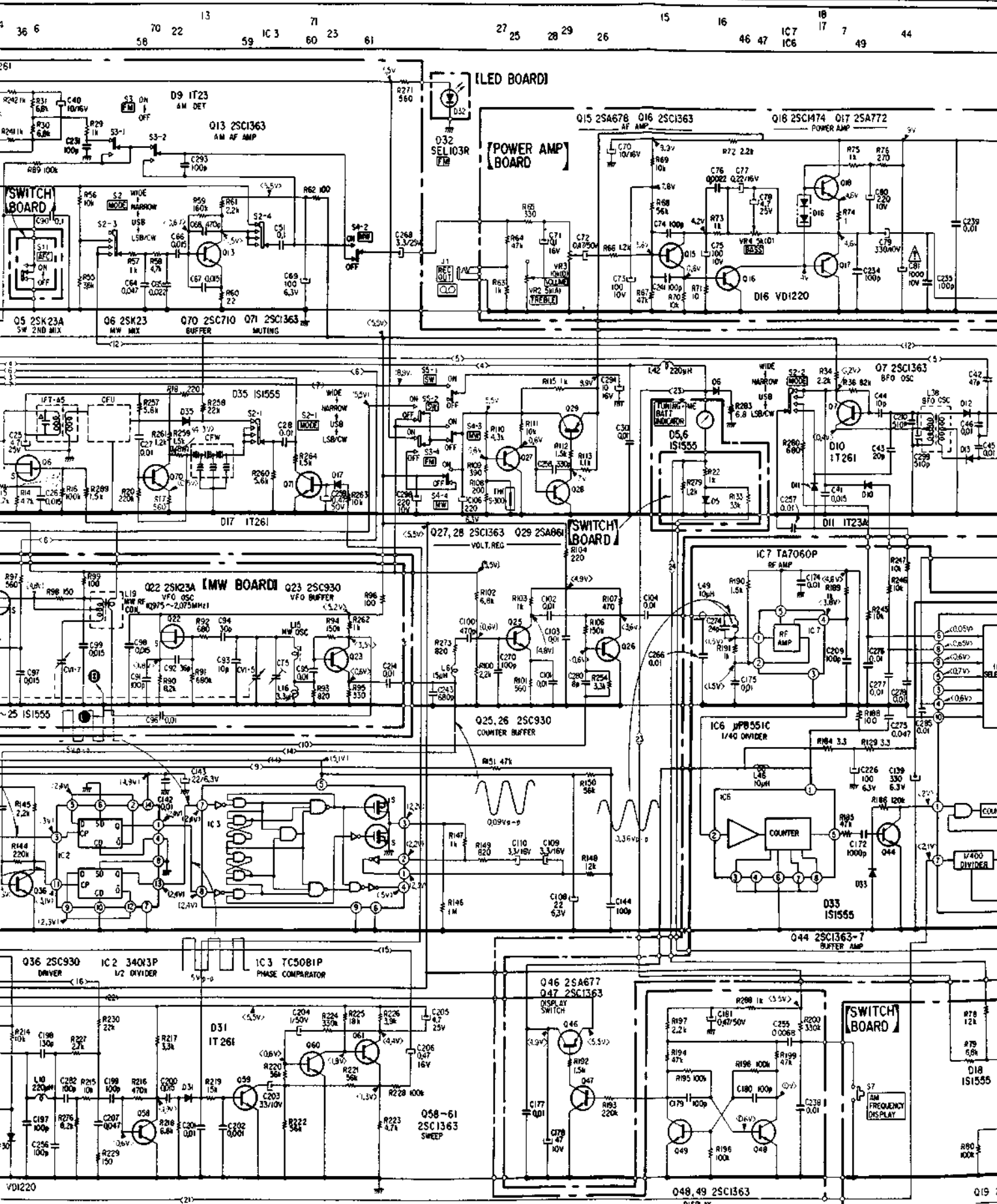

For Service Manuals Contact
MAURITRON TECHNICAL SERVICES
8 Cherry Tree Rd, Chinnor
Oxon OX9 4QY
Tel: 01844-351694 Fax: 01844-352554
Email: enquiries@mauritron.co.uk

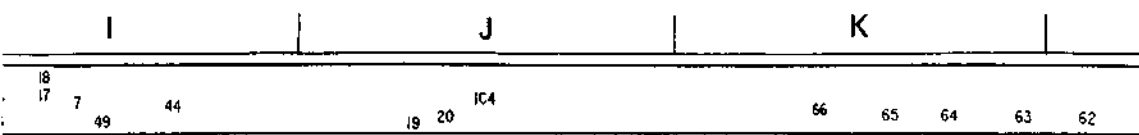



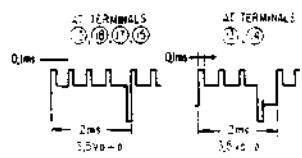
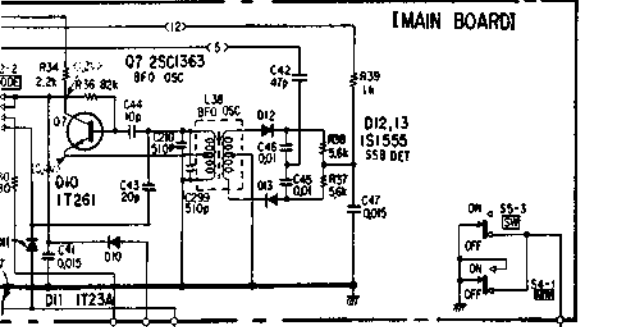
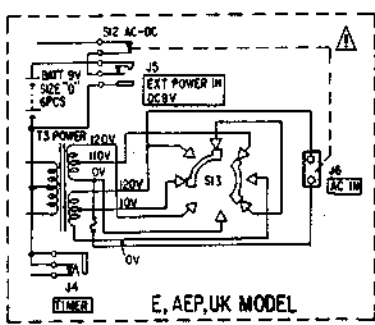
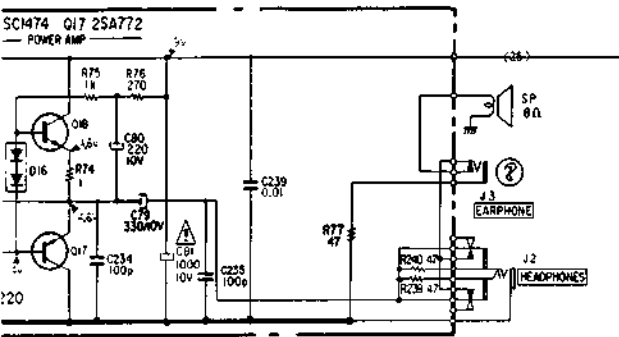

- Note:
- All capacitors are in μF 50 WV or less are not in
 - All resistors are in of $k\Omega = 1000 \Omega$, $M\Omega = 10$
 - : fusible resistor.
 - : chassis ground.
 - * : selected to yield.
 - Δ : internal compo
 - : panel designati
 - SW1 : 0 - 10 MHz (SW BAND SE
 - SW2 : 10 - 20 MHz (SW BAND SE
 - SW3 : 20 - 30 MHz (SW BAND SE
 - Voltages are dc with r noted.
 - Voltage variations ma duction tolerances.
 - : adjustment for
 - : B+ bus.

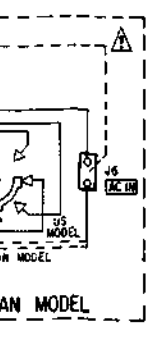
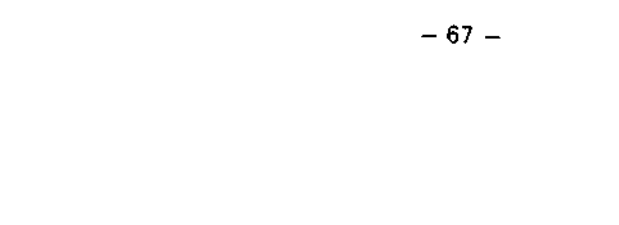
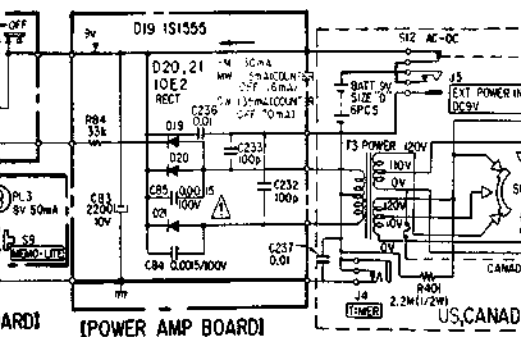
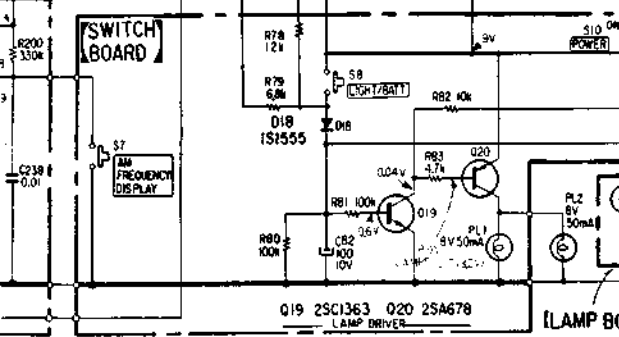
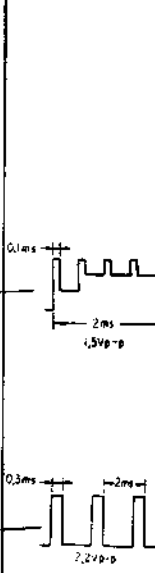
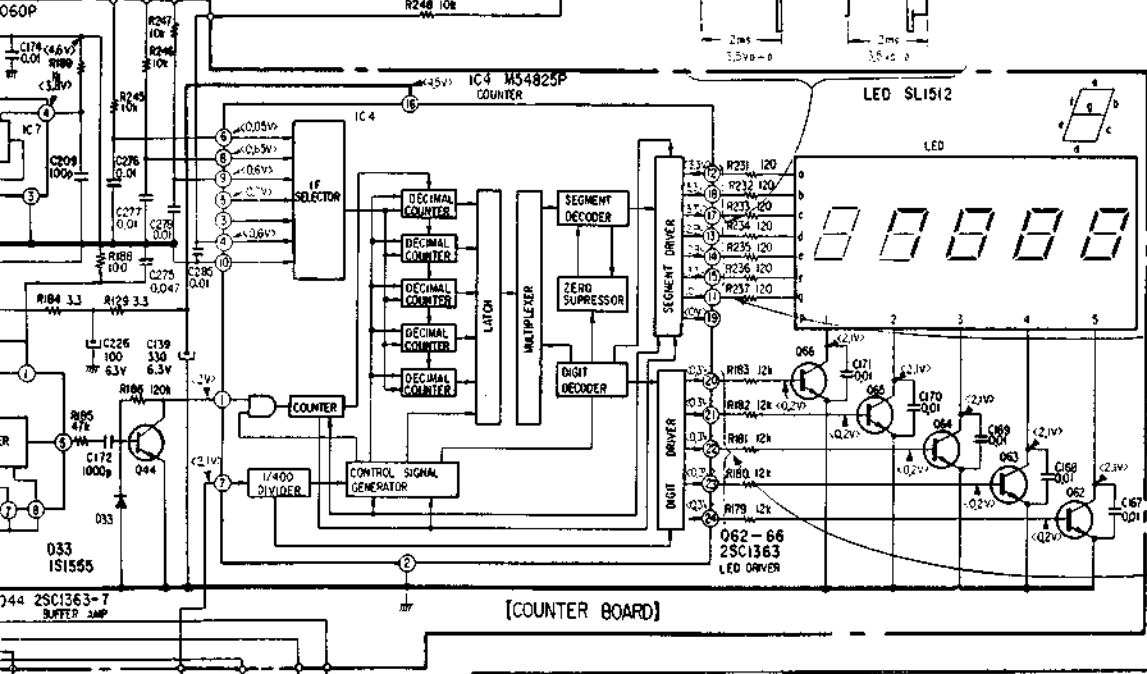

Note: The components in Δ are critical for part number speci





Note:

- All capacitors are in μF unless otherwise noted. $\text{pF} = \mu\mu\text{F}$
50 WV or less are not indicated except for electrolytics.
- All resistors are in ohms, $\frac{1}{4}\text{W}$ unless otherwise noted.
 $\text{k}\Omega = 1000 \Omega$, $\text{M}\Omega = 1000 \text{k}\Omega$
-  : fusible resistor.
-  : chassis ground.
- * : selected to yield optimum performance.
- Δ : internal component.
-  : panel designation.
- SW1 : 0 – 10 MHz
(SW BAND SELECTOR in "0")
- SW2 : 10 – 20 MHz
(SW BAND SELECTOR in "10")
- SW3 : 20 – 30 MHz
(SW BAND SELECTOR in "20")
- Voltages are dc with respect to ground unless otherwise noted.
- Voltage variations may be noted due to normal production tolerances.
-  : adjustment for repair.
-  : B+ bus.

- Readings are taken under no-signal (detuned) conditions with a VOM (20 $\text{k}\Omega/\text{V}$).
() : SW
[] : MW
< > : AM (MW and SW)
no mark : FM
- Switch

Ref. No.	Switch	Position
S1	SW-ANT	ROD
S2	MODE	WIDE
S3	FM	ON
S4	MW	OFF
S5	SW	OFF
S6	SW BAND SELECTOR	0
S7	AM FREQUENCY DISPLAY	OFF
S8	LIGHT/BATT	OFF
S9	MEMO-LITE	OFF
S10	POWER	OFF
S11	AFC	OFF
S12	AC/DC	DC
S14	RF ATT	DX

Note: The components identified by shading and mark  are critical for safety. Replace only with part number specified.

Note: Les composants identifiés par un tramé et une marque  sont critiques pour la sécurité. Ne les remplacer que par une pièce portant le numéro spécifié.

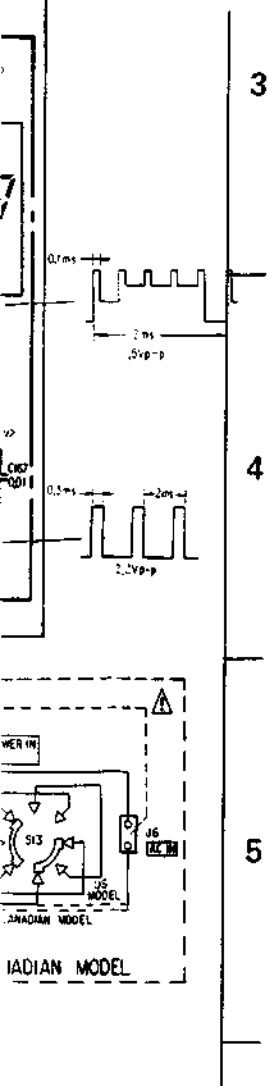

For Service Manuals Contact
MAURITRON TECHNICAL SERVICES
 8 Cherry Tree Rd, Chinnor
 Oxon OX9 4QY
 Tel: 01844-351694 Fax: 01844-352554
 Email: enquiries@mauritron.co.uk

4-6. MOUNTING DIAGRAM
- Conductor Side -
(Serial No. 30,001 and later)

1

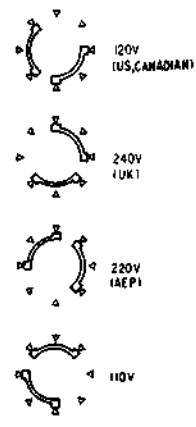
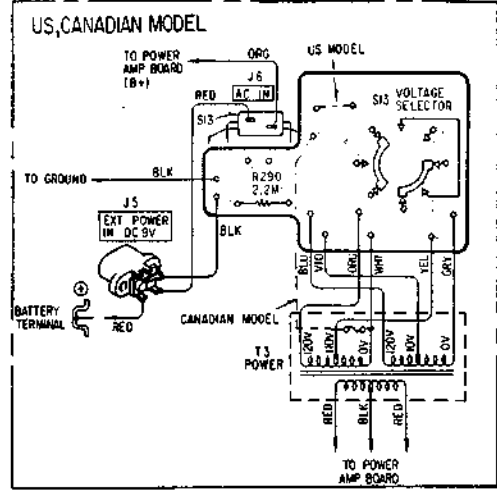
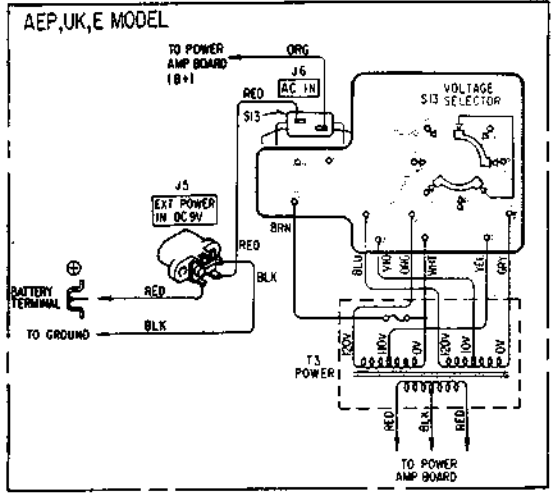

2

3

4

5

A

B

C

D

1

2

3

4

5

Q, IC	0
49, 48	
2	
3	
50	
61	
67	
60	
25	
59	
5	
58	
6	
4	31
41	
26	
55	30
53, 40	
57	
39, 70	
56	
43, 38	
14	10
42	28
71	17, 22
11, 21	8, 7
103	
12	9
10	11
30	101
35	14
37	102
31	7
9	9
29, 8	27
36, 34	
68	
27	
28	13, 12
13	
32	
33	
Q, IC	0

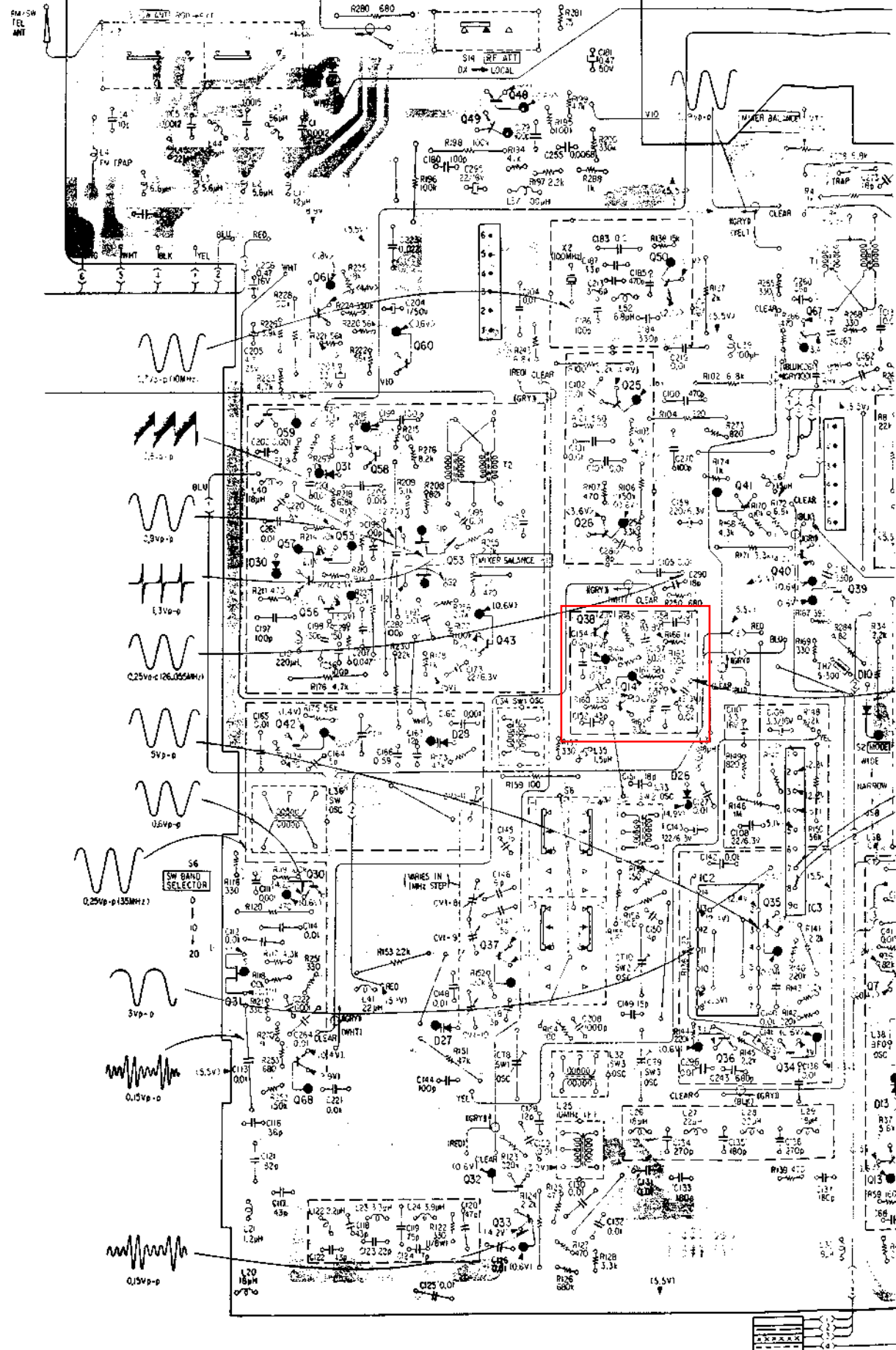

C

D

E

F

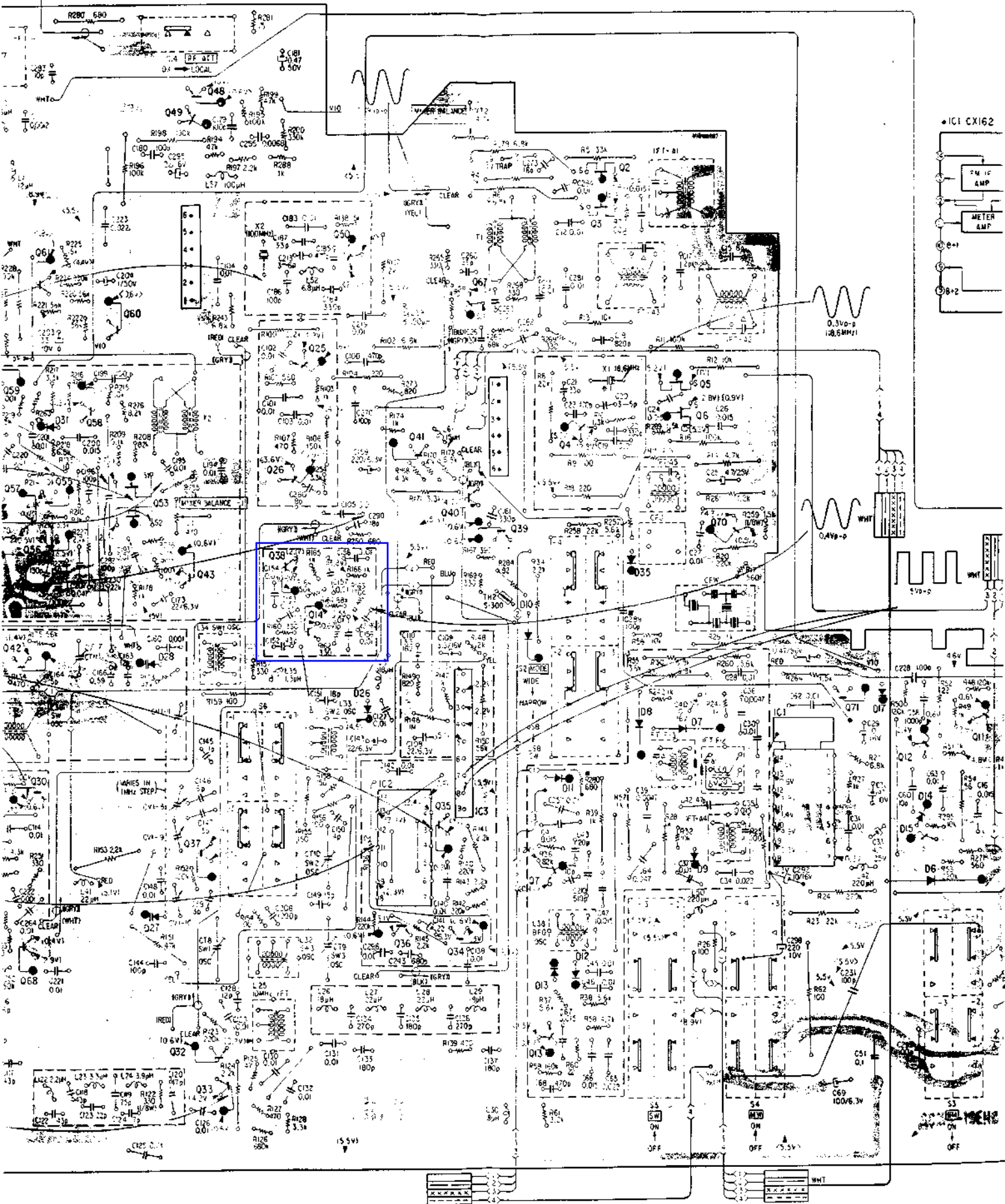

F

G

1

2

3

4

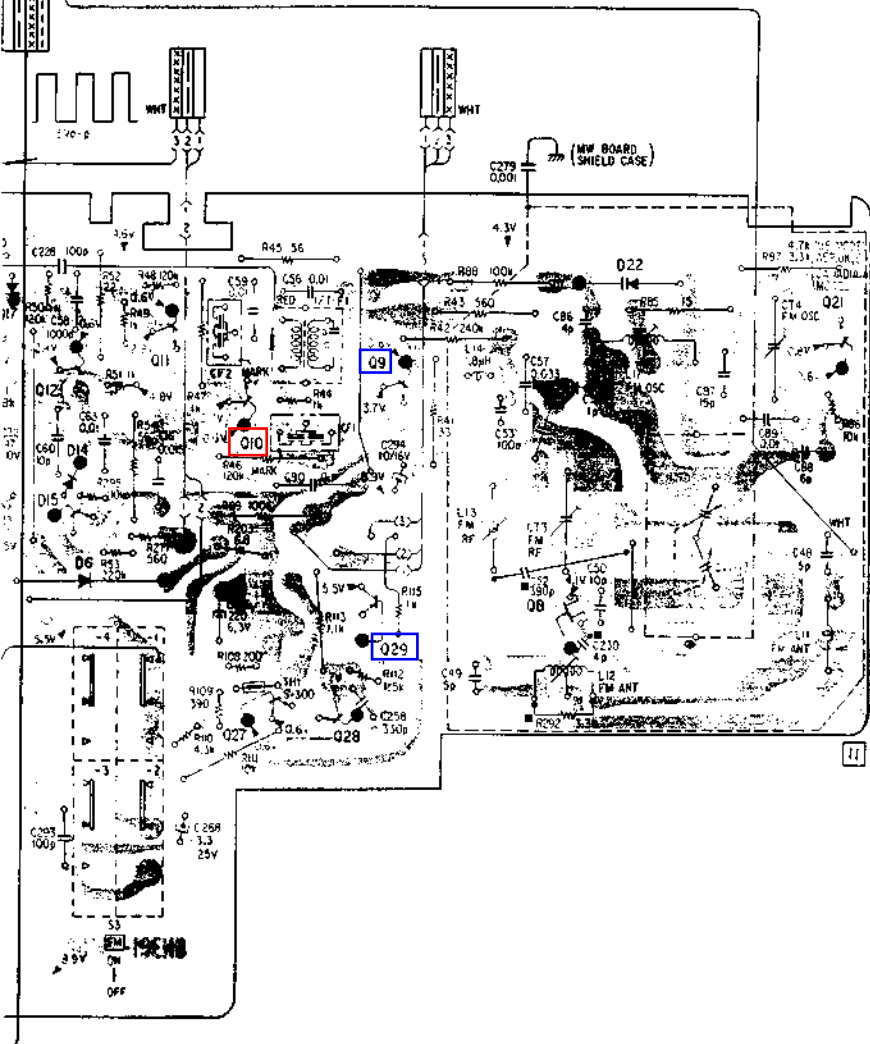
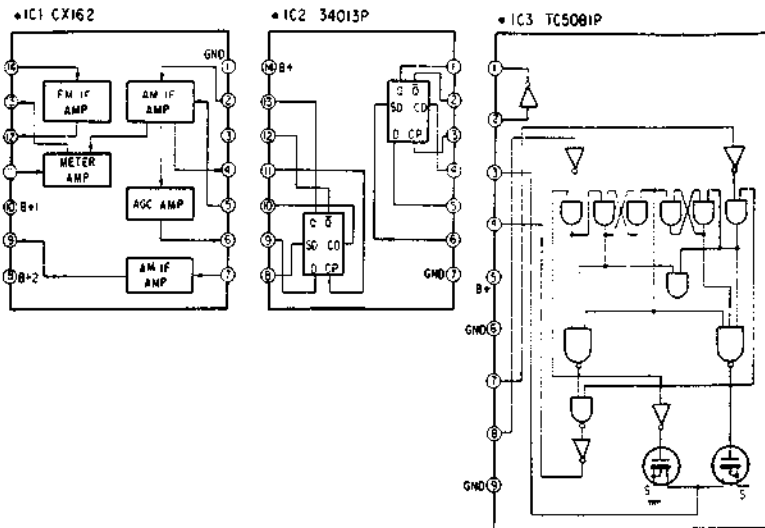

For Service Manuals Contact
MAURITRON TECHNICAL SERVICES
 8 Cherry Tree Rd, Chinnor
 Oxon OX9 4QY
 Tel: 01844-351694 Fax: 01844-352554
 Email: enquiries@mauritron.co.uk

- Note:**
- ○ — : parts extracted from the component side.
 - ● — : parts extracted from the conductor side.
 - ■ — : part mounted on the conductor side.
 - □ — : indicates side identified with part number.
 - — : B+ pattern

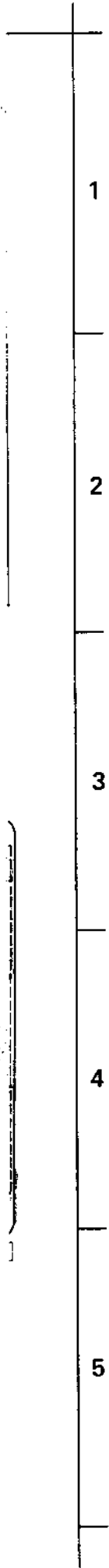

1

2

3

4

5

Note:

- ○ : parts extracted from the component side.
- ● : parts extracted from the conductor side.
- ■ : part mounted on the conductor side.
- □ : indicates side identified with part number.
- B+ pattern



For Service Manuals Contact
MAURITRON TECHNICAL SERVICES
6 Cherry Tree Rd, Chinnor
Oxon OX9 4QY
Tel: 01844-351694 Fax: 01844-352554
Email: enquiries@mauritron.co.uk

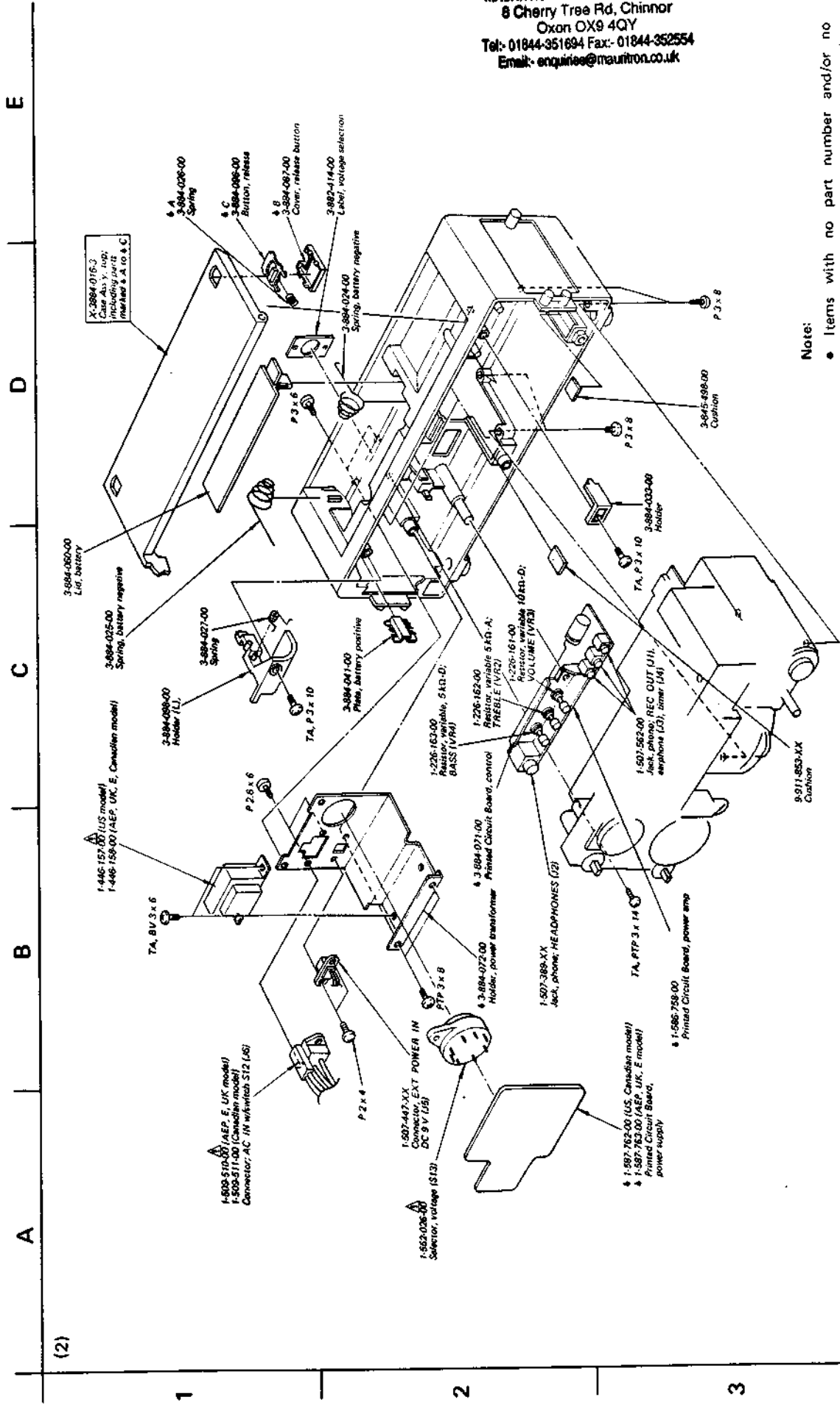

Note:

- Items with no part number and/or no description are not stocked because they are seldom required for routine service.
- All screws are Phillips (cross recess) type unless otherwise noted.
- Items marked "A" are not stocked since they are seldom required for routine service. Some delay should be anticipated when ordering these items.

Note: Les composants identifiés par un trame et une marque A sont critiques pour la sécurité. Ne les remplacer que par une pièce portant le numéro spécifié.

Note: The components identified by shading and mark A are critical for safety. Replace only with part number specified.

(2)

1

2

3

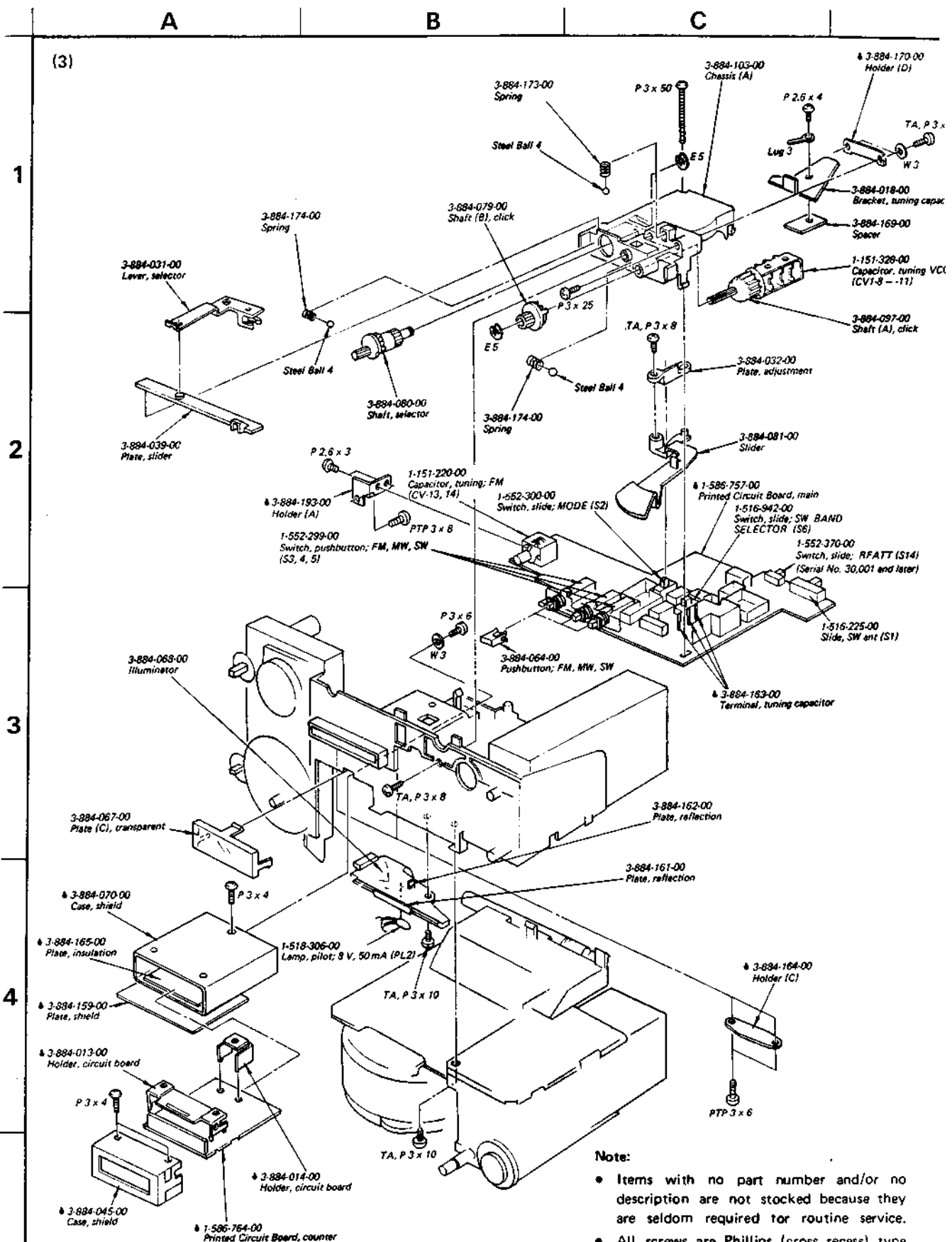

Note:

- Items with no part number and/or no description are not stocked because they are seldom required for routine service.
- All screws are Phillips (cross recess) type unless otherwise noted.
(-) = slotted head
- Items marked "*" are not stocked since they are seldom required for routine service. Some delay should be anticipated when ordering these items.

A B C D E

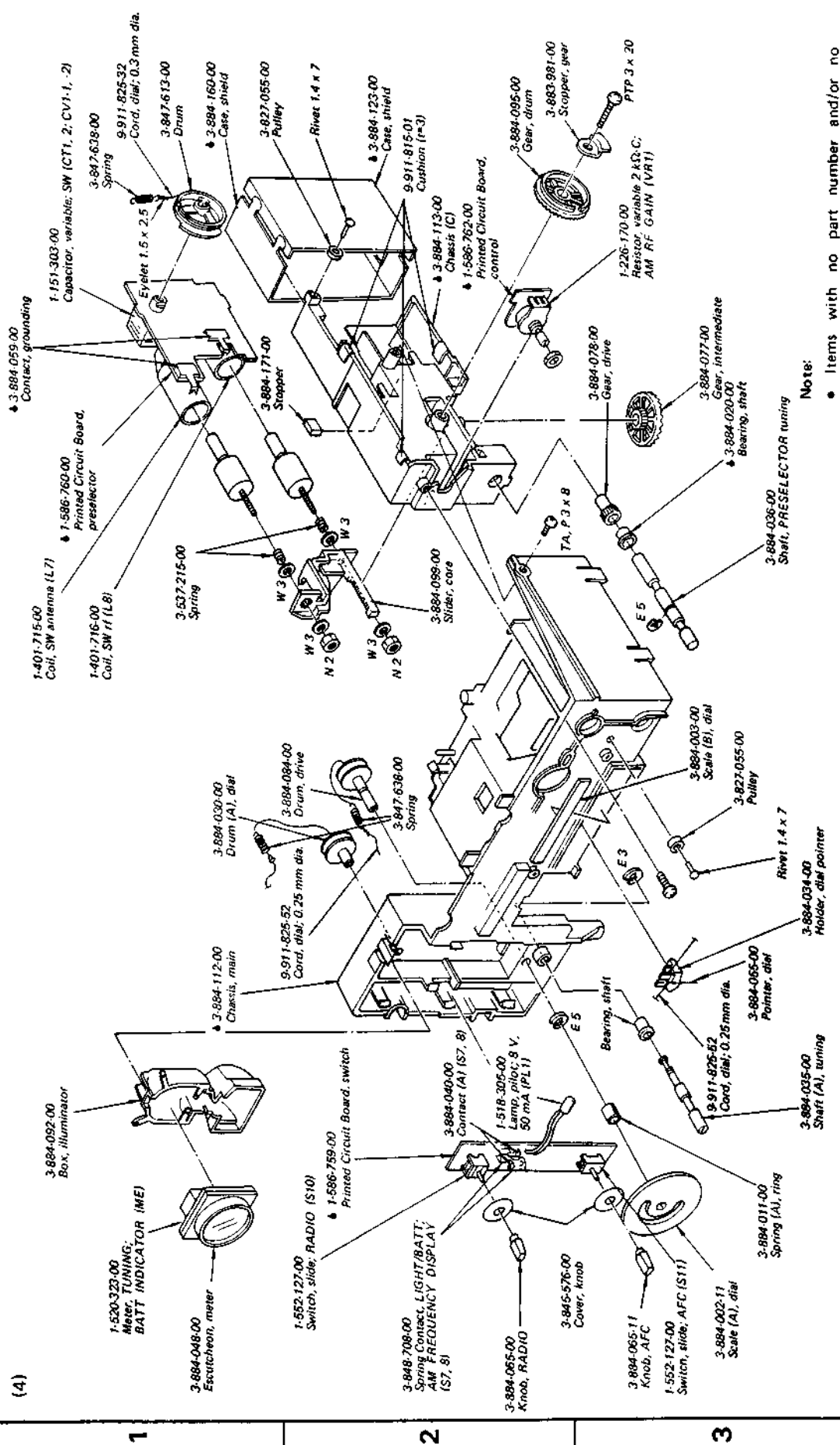

Note:

- Items with no part number and/or no description are not stocked because they are seldom required for routine service.
- All screws are Phillips (cross recess) type unless otherwise noted.
- Items marked "—" are not stocked since they are seldom required for routine service. Some delay should be anticipated when ordering.

For Service Manuals Contact
MAURITRON TECHNICAL SERVICES
 8 Cherry Tree Rd, Chinnor
 Oxon OX9 4QY
 Tel: 01844-351694 Fax: 01844-352554
 Email: enquiries@mauritron.co.uk

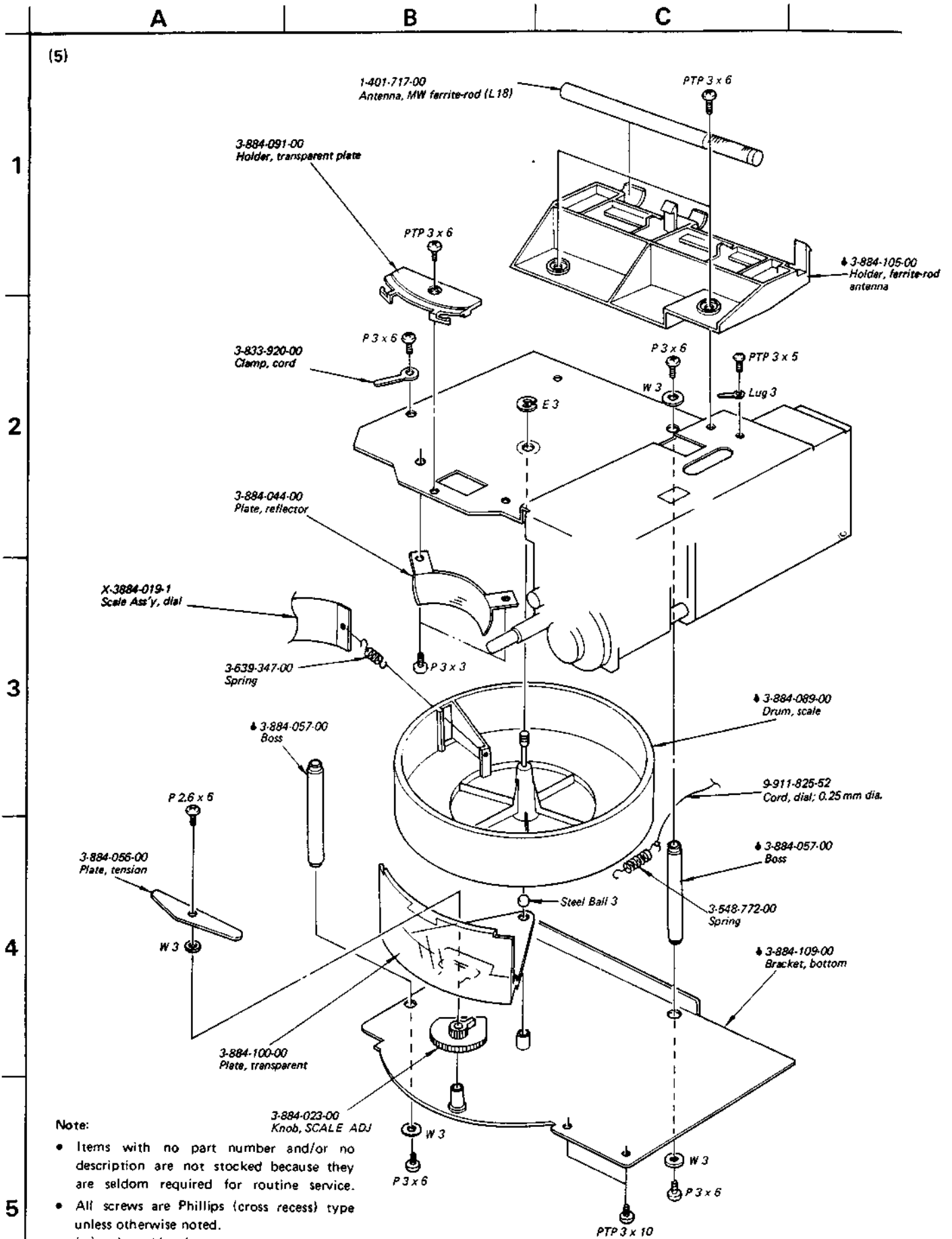

Note:

- Items with no part number and/or no description are not stocked because they are seldom required for routine service.
- All screws are Phillips (cross recess) type unless otherwise noted.
(-) = slotted head
- Items marked "*" are not stocked since they are seldom required for routine service. Some delay should be anticipated when ordering these items.

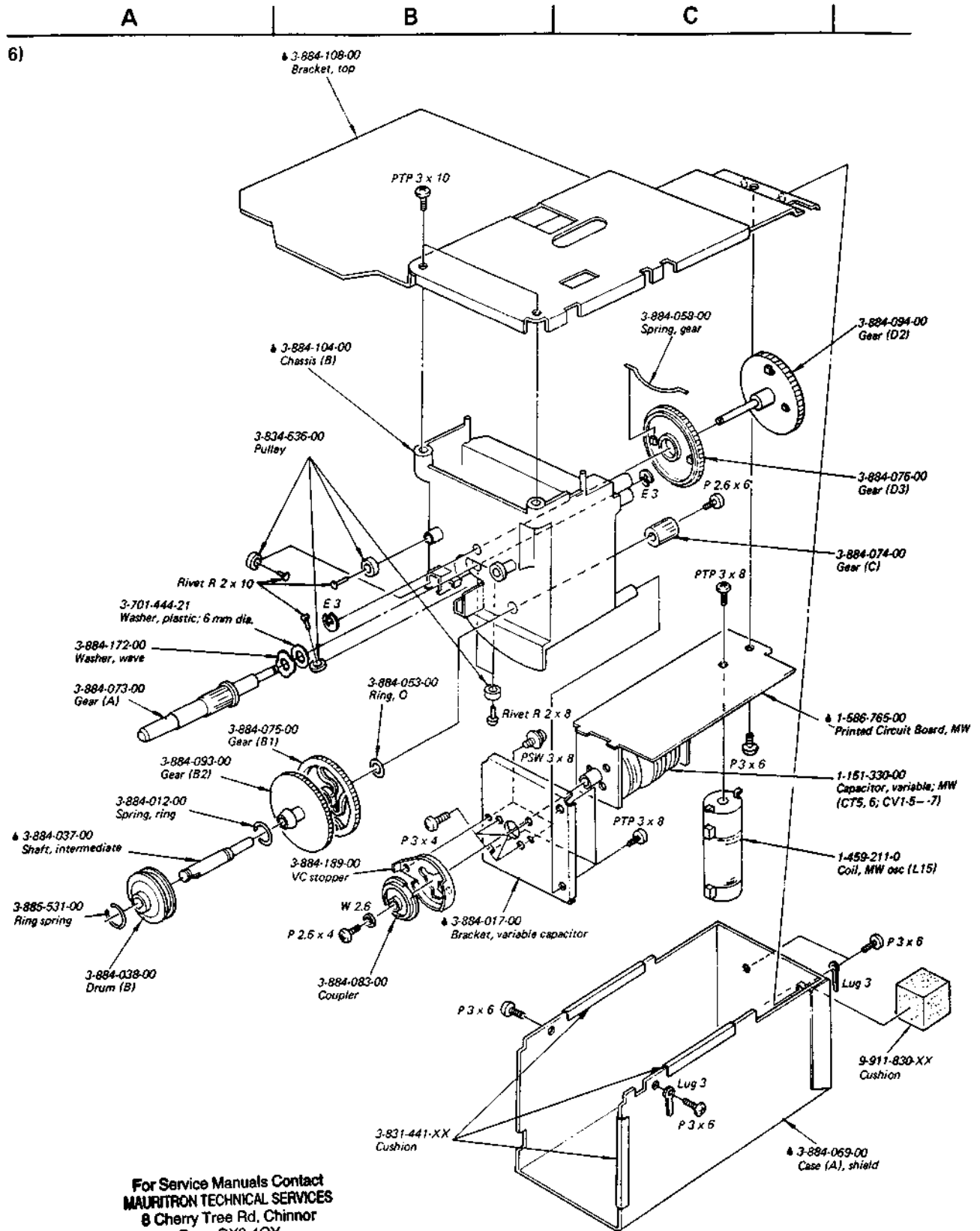

For Service Manuals Contact
MAURITRON TECHNICAL SERVICES
 8 Cherry Tree Rd, Chinnor
 Oxon OX9 4QY
 Tel: 01844-351894 Fax: 01844-352554
 Email: enquiries@mauritron.co.uk

Note:

- Items with no part number and/or no description are not stocked because they are seldom required for routine service.
- All screws are Phillips (cross recess) type unless otherwise noted.
(-) = slotted head
- Items marked "*" are not stocked since they are seldom required for routine service. Some delay should be anticipated when ordering these items.

SECTION 6

ELECTRICAL PARTS LIST

<u>Ref. No.</u>	<u>Part No.</u>	<u>Description</u>	<u>Ref. No.</u>	<u>Part No.</u>	<u>Description</u>
SEMICONDUCTORS					
Transistors					
Q1	8-722-762-00	3SK37	Q55-66	8-729-663-47	2SC1364
Q2, 3	8-722-384-01	2SK23A	Q67, 68	8-729-803-04	2SC930
Q4	8-729-803-04	2SC930	Q70	8-729-671-13	2SC710-13
Q5, 6	8-769-200-24	2SK107-24	Q71	8-729-663-47	2SC1364
Q7	8-729-663-47	2SC1364	Q72	8-729-663-47	2SC1364 (Serial No. up to 30,0
Q8	8-727-312-00	2SK42-2	Diodes		
Q9-12	8-729-803-04	2SC930	D1-6	8-719-815-55	1S1555
Q13	8-729-663-47	2SC1364	D7, 8	8-719-026-11	1T261
Q14	8-729-803-04	2SC930	D9	8-719-422-21	1T22AM
Q15	8-729-612-77	2SA1027R	D10	8-719-026-11	1T261
Q16	8-729-663-47	2SC1364	D11	8-719-422-21	1T23AM
Q17	8-760-514-10	2SA772-14	D12-14	8-719-815-55	1S1555
Q18	8-760-335-10	2SC1474	D15	8-729-803-04	2SC930
Q19	8-729-663-47	2SC1364	D16	8-719-122-00	VD1220
Q20	8-729-612-77	2SA1027R	D17	8-719-016-11	1T261
Q21	8-729-803-04	2SC930	D18	8-719-815-55	1S1555
Q22	8-722-384-01	2SK23A-840 Blue	D19	▲ 8-719-815-55	1S1555
Q23	8-729-803-04	2SC930	D20, 21	▲ 8-719-200-02	10E2
Q24	8-727-312-00	2SK42-2	D22	8-719-713-93	1S2139C
Q25, 26	8-729-803-04	2SC930	D23-25	8-719-815-55	1S1555
Q27, 28	8-729-663-47	2SC1364	D26	8-719-112-00	VD1120
Q29	8-763-213-00	2SA861	D27, 28	8-719-905-43	FC54E3
Q30	8-729-803-04	2SC930	D29	8-719-815-55	1S1555
Q31	8-722-384-01	2SK23A-840 Blue	D30	8-719-122-00	VD1220
Q32-36	8-729-803-04	2SC930	D31	8-719-026-11	1T261
Q37	8-729-866-84	2SC668-SP	D32	8-719-301-03	SEL103R
Q38	8-729-803-04	2SC930	D33	8-719-815-55	1S1555
Q39, 40	8-729-663-47	2SC1364	LED	8-719-905-12	SL1512
Q41	8-729-612-77	2SA1027R	ICs		
Q42, 43	8-729-803-04	2SC930	IC1	8-751-620-00	CX162
Q44	8-729-663-47	2SC1364	IC2	8-759-140-13	MB84013
Q46	8-729-612-77	2SA1027R	IC3	8-759-250-81	TCS081P
Q47-49	8-729-663-47	2SC1364	IC4	8-759-648-25	M54825P
Q50	8-729-803-04	2SC930	IC6	8-759-155-10	μPB551C
Q51	8-729-803-04	2SC930	IC7	8-759-270-60	TA7060P
Q53	8-761-510-06	2SK58	IC8	8-759-902-90	SN74LS290N
Thermistor					
			Th1, 2	1-800-071-XX	S-300

Note: The components identified by shading and mark ▲ are critical for safety. Replace only with part number specified.

Note: Les composants identifiés par un tramé et une marque ▲ sont critiques pour la sécurité. Ne les remplacer que par une pièce portant le numéro spécifié.

<u>Ref. No.</u>	<u>Part No.</u>	<u>Description</u>
TRANSFORMERS		
T1, 2	1-417-033-00	Matching
T3	△ 1-446-158-00	Power (AEP, UK, Canadian, E model)
T3	△ 1-446-157-00	(US model)
IFT-A1	1-404-098-00	IFT, SW
IFT-A2, 3	1-404-099-00	IFT, SW
IFT-A4	1-404-100-00	IFT, MW
IFT-A5	1-404-023-00	IFT (Serial No. 30,001 and later)
IFT-F1	1-403-872-00	IFT, FM
IFT-F2	1-403-959-00	IFT, FM
IFT-F3	1-403-953-00	IFT, FM

COILS		
L1	1-407-158-XX	Microinductor 12μH
L2, 3	1-407-187-XX	Microinductor 5.6μH
L5	1-407-188-XX	Microinductor 6.8μH
L6	1-407-159-XX	Microinductor 1.5μH
L7	1-401-715-00	Coil, SW antenna
L8	1-401-716-00	Coil, SW rf
L10	1-407-173-XX	Microinductor 220μH
L14	1-407-181-XX	Microinductor 1.8μH
L15	1-459-211-00	Coil, MW osc
L16	1-407-732-00	Microinductor 3.3μH
L18	1-401-717-00	Antenna, MW ferrite-rod
L19	1-425-975-00	Coil, MW rf
L20	1-407-160-XX	Microinductor 18μH
L21	1-407-179-00	Microinductor 1.2μH
L22	1-407-182-XX	Microinductor 2.2μH
L23	1-407-184-XX	Microinductor 3.3μH
L24	1-407-185-XX	Microinductor 3.9μH
L25	1-403-953-00	10 MHz IFT
L26	1-407-160-XX	Microinductor 18μH
L27, 28	1-407-161-XX	Microinductor 22μH
L29-31	1-407-160-XX	Microinductor 18μH
L32	1-405-783-00	Coil, SW 3 osc
L33	1-405-782-00	Coil, SW 2 osc
L34	1-405-781-00	Coil, SW 1 osc
L35	1-407-180-XX	Microinductor 1.5 μH
L36	1-405-713-00	Coil, SW osc
L37	1-407-856-00	Coil, choke
L38	1-407-192-XX	Coil, VFO osc
L39	1-407-169-XX	Microinductor 100μH
L40	1-407-160-XX	Microinductor 18μH

Note: Les composants identifiés par une trame et une marque **△** sont critiques pour la sécurité. Ne les remplacer que par une pièce portant le numéro spécifié.

<u>Ref. No.</u>	<u>Part No.</u>	<u>Description</u>
L41	1-407-161-XX	Microinductor 22 μH
L42	1-407-173-XX	Microinductor 220 μH
L43	1-407-166-XX	Microinductor 56 μH
L44	1-407-159-XX	Microinductor 15 μH
L45	1-407-161-XX	Microinductor 22 μH
L46	1-407-157-XX	Microinductor 10 μH
L49	1-407-157-XX	Microinductor 10 μH
L50	1-407-173-XX	Microinductor 220 μH
L51	1-407-178-XX	Microinductor 1 μH
L52	1-407-188-XX	Microinductor 6.8 μH (Serial No. up to 30,000)
L52	1-407-188-XX	Microinductor 18 μH (Serial No. 30,001 and later)
L53	1-407-157-XX	Microinductor 10 μH
L55, 56	1-407-178-XX	Microinductor 1 μH (Serial No. 30,001 and later)
L57	1-407-169-XX	Microinductor 100 μH (Serial No. 30,001 and later)

CAPACITORS

All capacitors are in μF and ceramic unless otherwise noted. 50 WV or less are not indicated except for electrolytics.
 μF : μμF, elect : electrolytic

C81	△ 1-121-943-00	1,000 10V elect
C83	△ 1-123-074-00	2,200 10V elect
C84, 85	△ 1-108-364-00	0,0015 mylar
CT1, 2	1-151-303-00	Variable; SW
CV1-1, 2		
CT5, 6	1-151-330-00	Variable; MW
CV1-5-7		
CT3, 4	1-141-138-XX	Trimmer
CT8-10	1-141-138-XX	Trimmer
CT11	1-141-229-00	Trimmer
CV1-8-11	1-151-328-00	Variable; VC01, 2
CV1-13, 14	1-151-330-00	Variable; FM

RESISTORS

All resistors are in ohms. Common 1/4 W carbon resistors are omitted. Refer to the list on the last page for their part numbers.

R401	△ 1-202-723-00	2.2M 1/4 W composition (Canadian model)
VR1	1-226-170-00	Variable, 2 kΩ-C; AM RF GAIN
VR2	1-226-162-00	Variable, 5 kΩ-A; TREBLE
VR3	1-226-161-00	Variable, 10 kΩ-D; VOLUME
VR4	1-226-163-00	Variable, 5 kΩ-D; BASS

Note: The components identified by shading and mark **△** are critical for safety. Replace only with part number specified.

For Service Manuals Contact
MAURITRON TECHNICAL SERVICES
 8 Cherry Tree Rd, Chinnor
 Oxon OX9 4QY
 Tel: 01844-351894 Fax: 01844-352554
 Email: enquiries@mauritron.co.uk

<u>Ref. No.</u>	<u>Part No.</u>	<u>Description</u>
VT1	1-224-248-XX	Adjustable; 470 Ω-B; MIXER BALANCE 1
VT2	1-224-251-XX	Adjustable, 4.7 kΩ-B; MIXER BALANCE 2
SWITCHES		
S1	1-516-225-00	Slide; SW ant
S2	1-552-300-00	Slide; MODE
S3, 4, 5	1-552-299-00	Pushbutton; FM, MW, SW
S6	1-516-942-00	Slide; SW BAND SELECTOR
S7, 8	3-848-708-00	Spring Contact; LIGHT/BATT, AM FREQUENCY DISPLAY
	3-884-040-00	Contact (A)
S9	3-884-029-00	Spring Contact; MEMO-LITE
S10, 11	1-552-127-00	Slide; RADIO, AFC
S12		Included in J6
S13	▲1-552-026-00	Selector, voltage
S14	1-552-370-00	Slide; RF ATT (Serial No. 30,001 and later)
JACKS		
J1	1-507-562-00	Phone; REC OUT
J2	1-507-389-XX	Phone; HEADPHONES
J3, 4	1-507-562-00	Mini; earphone, timer
J5	1-507-447-XX	Connector; EXT POWER IN DC 9 V
J6	▲1-509-510-00	Connector; AC IN w/switch S12 (AEP, E, UK model)
	▲1-509-511-00	Connector; AC IN w/switch S12 (US, CANADIAN model)

For Service Manuals Contact
MAURITRON TECHNICAL SERVICES
 8 Cherry Tree Rd, Chinnor
 Oxon OX9 4QY
 Tel: 01844-351694 Fax: 01844-352554
 Email: enquiries@mauritron.co.uk

<u>Ref. No.</u>	<u>Part No.</u>	<u>Description</u>
MISCELLANEOUS		
TEL ANT	1-501-177-00	Antenna, telescopic
CF1, 2	1-527-184-XX	Filter, ceramic; 10.7 MHz (Serial No. up to 30,000)
CF1, 2	1-527-795-71	Filter, ceramic; 10.7 MHz (Serial No. 30,001 and later)
CFT	1-403-144-00	Filter, ceramic (Serial No. up to 30,000)
CFU	1-527-319-00	Filter, ceramic (Serial No. up to 30,000)
CFU	1-527-290-00	Filter, ceramic (Serial No. 30,001 and later)
CFW	1-527-569-00	Filter, ceramic (Serial No. 30,001 and later)
CNJ1	1-509-926-00	Connector, M-type coaxial
ME	1-520-323-00	Meter; TUNNING, BATT INDICATOR
PL1	1-518-305-00	Lamp, pilot; 8 V, 50 mA
PL2	1-518-306-00	Lamp, pilot; 8 V, 50 mA
PL3	1-518-305-00	Lamp, pilot; 8 V, 50 mA
SP	1-502-694-00	Speaker
X1	1-527-318-00	Unit, crystal; 18.6 MHz
X2	1-527-317-00	Unit, crystal; 10 MHz
	1-536-524-00	Strip, terminal; 4-p

ACCESSORIES & PACKING MATERIALS	
<u>Part No.</u>	<u>Description</u>
▲1-534-840-XX	Cord, power; DK-38 (AEP model)
▲1-551-218-00	Cord, power; DK-50 (UK model)
▲1-551-235-00	Cord, power; DK-51 (E model)
▲1-551-504-00	Cord, power; (US, Canadian model)
1-551-521-00	Cord, power; DK-52 (E model)
3-551-895-00	Bag, protection
3-884-119-00	Cushion (L)
3-884-120-00	Cushion (R)
3-884-122-00	Spacer, dial
3-884-176-00	Pin, antenna terminal
3-993-063-11	Guide, shortwave
3-993-171-11	Instruction, antenna terminal
3-995-830-11	Manual, instruction

Note: The components identified by shading and mark ▲ are critical for safety. Replace only with part number specified.

Note: Les composants identifiés par une trame et une marque ▲ sont critiques pour la sécurité. Ne les remplacer que par une pièce portant le numéro spécifié.

ELECTROLYTIC CAPACITORS

CAP. (μF)	RATING → : Use the high voltage rated one.					
	6.3 VOLT.	10 VOLT.	16 VOLT.	25 VOLT.	35 VOLT.	50 VOLT.
	PART No.	PART No.	PART No.	PART No.	PART No.	PART No.
0.47					→	1-121-726-00
1.0					→	1-121-391-00
2.2					→	1-121-450-00
3.3	→	→	→	1-121-392-00	→	1-121-393-00
4.7	→	→	→	1-121-395-00	→	1-121-396-00
10	→	→	1-121-651-00	1-121-398-00	→	1-121-738-00
22	→	→	1-121-479-00	1-121-480-00	1-121-662-00	1-121-152-00
33	→	→	1-121-403-00	1-121-404-00	1-121-652-00	1-121-405-00
47	→	1-121-352-00	1-121-409-00	1-121-410-00	1-121-653-00	1-121-411-00
100	→	1-121-414-00	1-121-415-00	1-121-416-00	1-121-357-00	1-121-417-00
220	1-121-419-00	1-121-420-00	1-121-421-00	1-121-422-00	1-121-261-00	1-121-423-00
330	1-121-751-00	1-121-805-00	1-121-521-00	1-121-654-00	1-121-655-00	1-121-656-00
470	1-121-424-00	1-121-425-00	1-121-426-00	1-121-733-00	1-121-361-00	1-121-810-00
1000		1-121-736-00	1-121-245-00	1-121-657-00	1-121-388-00	1-123-061-00
2200	1-121-658-00	1-121-659-00	1-121-660-00	1-123-067-00	1-121-984-00	-
3300	1-121-661-00	1-123-075-00	1-123-071-00	-	-	-

CAP. (μF)	100 VOLT.	160 VOLT.	250 VOLT.	350 VOLT.
	PART No.	PART No.	PART No.	PART No.
0.47	-	-	-	-
1.0	1-123-249-00	1-123-252-00	1-123-003-00	1-121-168-00
2.2	1-123-250-00	1-123-026-00	-	1-123-028-00
3.3	1-121-995-00	-	1-123-004-00	1-123-006-00
4.7	1-123-255-00	1-121-246-00	1-121-759-00	1-123-007-00
10	1-121-126-00	1-121-999-00	1-123-254-00	1-123-008-00
22	1-121-996-00	1-123-253-00	1-123-005-00	1-123-022-00
33	1-121-997-00	1-121-757-00	-	-
47	1-123-251-00	1-121-919-00	-	-
100	1-123-084-00	-	-	-

CERAMIC CAPACITORS

RATING							
CAP. (pF)	50 VOLT.	CAP. (pF)	50 VOLT.	CAP. (pF)	50 VOLT.	CAP. (μF)	50 VOLT.
	PART No.		PART No.		PART No.		PART No.
0.5	1-101-837-00	22	1-102-959-00	150	1-101-361-00	0.001	1-102-074-00
0.75	1-101-586-00	24	1-102-960-00	160	1-101-367-00	0.0012	1-102-118-00
1.0	1-102-934-00	27	1-102-961-00	180	1-102-976-00	0.0015	1-102-119-00
1.5	1-101-576-00	30	1-102-962-00	200	1-102-977-00	0.0018	1-102-120-00
2.0	1-102-935-00	33	1-102-963-00	220	1-102-978-00	0.0022	1-102-121-00
3	1-102-936-00	36	1-102-964-00	240	1-102-979-00	0.0027	1-102-122-00
4	1-102-937-00	39	1-102-965-00	270	1-102-980-00	0.0033	1-102-123-00
5	1-102-942-00	43	1-102-966-00	300	1-102-981-00	0.0039	1-102-124-00
6	1-102-943-00	47	1-101-880-00	330	1-102-820-00	0.0047	1-102-125-00
7	1-102-944-00	51	1-101-882-00	360	1-102-821-00	0.0056	1-102-126-00
8	1-102-945-00	56	1-101-884-00	390	1-102-822-00	0.0068	1-102-127-00
9	1-102-946-00	62	1-101-886-00	430	1-102-823-00	0.0082	1-102-128-00
10	1-102-947-00	68	1-101-888-00	470	1-102-824-00	0.01	1-102-129-00
11	1-102-948-00	75	1-101-890-00	510	1-101-059-00	0.022	1-101-005-00
12	1-102-949-00	82	1-102-971-00	560	1-102-115-00	0.047	1-101-006-00
13	1-102-950-00	91	1-102-972-00	600	1-102-116-00		
15	1-102-951-00	100	1-102-973-00	820	1-102-117-00		
16	1-102-952-00	110	1-102-815-00				
18	1-102-953-00	120	1-102-816-00				
20	1-102-958-00	130	1-101-081-00				

0.001μF = 1,000pF

CERAMIC (SEMICONDUCTOR) CAPACITORS

RATING → : Use the high voltage rated one.					
CAP. (μF)	25 VOLT.	50 VOLT.	CAP. (μF)	25 VOLT.	50 VOLT.
	PART No.	PART No.		PART No.	PART No.
0.001	→	1-161-039-00	0.018	1-161-016-00	1-161-054-00
0.0012	→	1-161-040-00	0.022	1-161-017-00	1-161-055-00
0.0015		1-161-041-00	0.027	1-161-018-00	1-161-056-00
0.0018		1-161-042-00	0.033	1-161-019-00	1-161-057-00
0.0022		1-161-043-00	0.039	1-161-010-00	1-161-058-00
0.0027	→	1-161-044-00	0.047	1-161-021-00	1-161-059-00
0.0033	→	1-161-045-00	0.056	→	1-161-060-00
0.0039	→	1-161-046-00	0.068	→	1-161-061-00
0.0047	→	1-161-047-00	0.082	1-161-024-00	1-161-062-00
0.0056	→	1-161-048-00	0.1	1-161-025-00	1-161-063-00
0.0068	→	1-161-049-00			
0.0082	1-161-012-00	1-161-050-00			
0.01	1-161-013-00	1-161-051-00			
0.012	→	1-161-052-00			
0.015	1-161-015-00	1-161-053-00			

For Service Manuals Contact
MAURITRON TECHNICAL SERVICES
 8 Cherry Tree Rd, Chinnor
 Oxon OX9 4QY
 Tel: 01844-351694 Fax: 01844-352554
 Email: enquiries@mauratron.co.uk

MYLAR CAPACITORS

CAP. (μF)	RATING										
	50 VOLT.			100 VOLT.			200 VOLT.				
	PART No.	PART No.	PART No.	PART No.	PART No.	PART No.	PART No.	PART No.	PART No.		
0.001	1-108-227-00	1-108-365-00	1-108-409-00	0.01	1-108-239-00	1-108-377-00	1-108-421-00	0.1	1-108-251-00	1-108-389-00	1-108-433-00
0.0012	1-108-351-00	1-108-366-00	1-108-410-00	0.012	1-108-357-00	1-108-378-00	1-108-422-00	0.12	1-108-363-00	1-108-390-00	1-108-434-00
0.0015	1-108-228-00	1-108-367-00	1-108-411-00	0.015	1-108-240-00	1-108-379-00	1-108-423-00	0.15	1-108-252-00	1-108-391-00	1-108-435-00
0.0018	1-108-352-00	1-108-368-00	1-108-412-00	0.018	1-108-358-00	1-108-380-00	1-108-424-00	0.18	1-108-364-00	1-108-392-00	1-108-436-00
0.0022	1-108-230-00	1-108-369-00	1-108-413-00	0.022	1-108-242-00	1-108-381-00	1-108-425-00	0.22	1-108-254-00	1-108-393-00	1-108-437-00
0.0027	1-108-353-00	1-108-370-00	1-108-414-00	0.027	1-108-359-00	1-108-382-00	1-108-426-00	0.27	1-108-854-00	-	-
0.0033	1-108-232-00	1-108-371-00	1-108-415-00	0.033	1-108-244-00	1-108-383-00	1-108-427-00	0.33	1-108-855-00	-	-
0.0039	1-108-354-00	1-108-372-00	1-108-416-00	0.039	1-108-360-00	1-108-384-00	1-108-428-00	0.39	1-108-856-00	-	-
0.0047	1-108-234-00	1-108-373-00	1-108-417-00	0.047	1-108-246-00	1-108-385-00	1-108-429-00	0.47	1-108-857-00	-	-
0.0056	1-108-355-00	1-108-374-00	1-108-418-00	0.056	1-108-361-00	1-108-386-00	1-108-430-00				
0.0068	1-108-237-00	1-108-375-00	1-108-419-00	0.068	1-108-249-00	1-108-387-00	1-108-431-00				
0.0082	1-108-356-00	1-108-376-00	1-108-420-00	0.082	1-108-362-00	1-108-388-00	1-108-432-00				



TANTALUM CAPACITORS

For Service Manuals Contact
MAURITRON TECHNICAL SERVICES
 8 Cherry Tree Rd, Chinnor
 Oxon OX9 4QY
 Tel: 01844-351694 Fax: 01844-352554
 Email: enquiries@mauritron.co.uk

CAP. (μF)	RATING → Use the high voltage rated one.						
	3.15 VOLT.	6.3 VOLT.	10 VOLT.	16 VOLT.	20 VOLT.	25 VOLT.	35 VOLT.
	PART No.	PART No.	PART No.	PART No.	PART No.	PART No.	PART No.
0.01							1-131-396-00
0.015							1-131-397-00
0.022							1-131-398-00
0.033							1-131-399-00
0.047							1-131-400-00
0.068							1-131-401-00
0.1							1-131-402-00
0.15							1-131-403-00
0.22							1-131-404-00
0.33						1-131-409-00	1-131-405-00
0.47						1-131-412-00	1-131-406-00
0.68				1-131-415-00		1-131-410-00	1-131-407-00
1.0			1-131-418-00		1-131-413-00		1-131-408-00
1.5		1-131-421-00		1-131-416-00		1-131-411-00	1-131-348-00
2.2	1-131-424-00		1-131-419-00		1-131-414-00	1-131-353-00	1-131-349-00
3.3		1-131-422-00		1-131-417-00	1-131-362-00	1-131-356-00	1-131-350-00
4.7	1-131-425-00		1-131-420-00	1-131-369-00	1-131-363-00	1-131-357-00	1-131-351-00
6.8		1-131-423-00	1-131-376-00	1-131-370-00	1-131-364-00	1-131-358-00	1-131-352-00
10	1-131-426-00	1-131-383-00	1-131-377-00	1-131-371-00	1-131-365-00	1-131-359-00	1-131-353-00
15	1-131-390-00	1-131-384-00	1-131-378-00	1-131-372-00	1-131-366-00	1-131-360-00	
22	1-131-391-00	1-131-385-00	1-131-379-00	1-131-373-00	1-131-367-00		
33	1-131-392-00	1-131-386-00	1-131-380-00	1-131-374-00			
47	1-131-393-00	1-131-387-00	1-131-381-00				
68	1-131-394-00	1-131-388-00					
100	1-131-395-00						

TANTALUM CAPACITORS

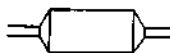

CAP. (μF)	RATING					
	3 VOLT.	6.3 VOLT.	10 VOLT.	16 VOLT.	20 VOLT.	35 VOLT.
	PART No.	PART No.	PART No.	PART No.	PART No.	PART No.
0.033						1-131-273-00
0.047						1-131-274-00
0.068						1-131-275-00
0.1						1-131-276-00
0.15						1-131-277-00
0.22					1-131-262-00	1-131-278-00
0.33					1-131-263-00	1-131-279-00
0.47			1-131-169-00		1-131-264-00	1-131-280-00
0.68				1-131-258-00	1-131-265-00	1-131-281-00
1.0			1-131-254-00		1-131-266-00	1-131-282-00
1.5		1-131-250-00			1-131-267-00	1-131-283-00
2.2				1-131-259-00	1-131-268-00	1-131-284-00
3.3			1-131-255-00		1-131-269-00	
4.7		1-131-251-00	1-131-171-00		1-131-270-00	
6.8				1-131-260-00	1-131-271-00	
10			1-131-256-00		1-131-272-00	
15		1-131-252-00		1-131-261-00		
22			1-131-257-00			
33	1-131-176-00	1-131-253-00	1-131-173-00			
47	1-131-288-00	1-131-174-00				
100	1-131-177-00					

1/4 WATT CARBON RESISTORS

Ω	Part No.	Ω	Part No.	Ω	Part No.	Ω	Part No.	Ω	Part No.	Ω	Part No.	Ω	Part No.
1.0	1-246-401-00	10	1-246-425-00	100	1-246-449-00	1.0k	1-246-473-00	10k	1-246-497-00	100k	1-246-521-00	1.0M	1-246-545-00
1.1	1-246-402-00	11	1-246-426-00	110	1-246-450-00	1.1k	1-246-474-00	11k	1-246-498-00	110k	1-246-522-00	1.1M	1-210-814-00
1.2	1-246-403-00	12	1-246-427-00	120	1-246-451-00	1.2k	1-246-475-00	12k	1-246-499-00	120k	1-246-523-00	1.2M	1-210-815-00
1.3	1-246-404-00	13	1-246-428-00	130	1-246-452-00	1.3k	1-246-476-00	13k	1-246-500-00	130k	1-246-524-00	1.3M	1-210-816-00
1.5	1-246-405-00	15	1-246-429-00	150	1-246-453-00	1.5k	1-246-477-00	15k	1-246-501-00	150k	1-246-525-00	1.5M	1-210-817-00
1.6	1-246-406-00	16	1-246-430-00	160	1-246-454-00	1.6k	1-246-478-00	16k	1-246-502-00	160k	1-246-526-00	1.6M	1-210-818-00
1.8	1-246-407-00	18	1-246-431-00	180	1-246-455-00	1.8k	1-246-479-00	18k	1-246-503-00	180k	1-246-527-00	1.8M	1-210-819-00
2.0	1-246-408-00	20	1-246-432-00	200	1-246-456-00	2.0k	1-246-480-00	20k	1-246-504-00	200k	1-246-528-00	2.0M	1-210-820-00
2.2	1-246-409-00	22	1-246-433-00	220	1-246-457-00	2.2k	1-246-481-00	22k	1-246-505-00	220k	1-246-529-00	2.2M	1-210-821-00
2.4	1-246-410-00	24	1-246-434-00	240	1-246-458-00	2.4k	1-246-482-00	24k	1-246-506-00	240k	1-246-530-00	2.4M	1-244-754-00
2.7	1-246-411-00	27	1-246-435-00	270	1-246-459-00	2.7k	1-246-483-00	27k	1-246-507-00	270k	1-246-531-00	2.7M	1-244-755-00
3.0	1-246-412-00	30	1-246-436-00	300	1-246-460-00	3.0k	1-246-484-00	30k	1-246-508-00	300k	1-246-532-00	3.0M	1-244-756-00
3.3	1-246-413-00	33	1-246-437-00	330	1-246-461-00	3.3k	1-246-485-00	33k	1-246-509-00	330k	1-246-533-00	3.3M	1-244-757-00
3.6	1-246-414-00	36	1-246-438-00	360	1-246-462-00	3.6k	1-246-486-00	36k	1-246-510-00	360k	1-246-534-00	3.6M	1-244-758-00
3.9	1-246-415-00	39	1-246-439-00	390	1-246-463-00	3.9k	1-246-487-00	39k	1-246-511-00	390k	1-246-535-00	3.9M	1-244-759-00
4.3	1-246-416-00	43	1-246-440-00	430	1-246-464-00	4.3k	1-246-488-00	43k	1-246-512-00	430k	1-246-536-00	4.3M	1-244-760-00
4.7	1-246-417-00	47	1-246-441-00	470	1-246-465-00	4.7k	1-246-489-00	47k	1-246-513-00	470k	1-246-537-00	4.7M	1-244-761-00
5.1	1-246-418-00	51	1-246-442-00	510	1-246-466-00	5.1k	1-246-490-00	51k	1-246-514-00	510k	1-246-538-00	5.1M	1-244-762-00
5.6	1-246-419-00	56	1-246-443-00	560	1-246-467-00	5.6k	1-246-491-00	56k	1-246-515-00	560k	1-246-539-00		
6.2	1-246-420-00	62	1-246-444-00	620	1-246-468-00	6.2k	1-246-492-00	62k	1-246-516-00	620k	1-246-540-00		
6.8	1-246-421-00	68	1-246-445-00	680	1-246-469-00	6.8k	1-246-493-00	68k	1-246-517-00	680k	1-246-541-00		
7.5	1-246-422-00	75	1-246-446-00	750	1-246-470-00	7.5k	1-246-494-00	75k	1-246-518-00	750k	1-246-542-00		
8.2	1-246-423-00	82	1-246-447-00	820	1-246-471-00	8.2k	1-246-495-00	82k	1-246-519-00	820k	1-246-543-00		
9.1	1-246-424-00	91	1-246-448-00	910	1-246-472-00	9.1k	1-246-496-00	91k	1-246-520-00	910k	1-246-544-00		

HARDWARE NOMENCLATURE

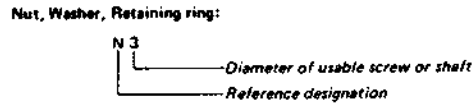
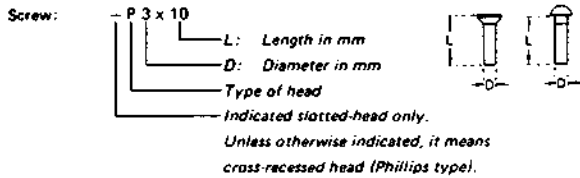

Reference Designation	Shape	Description	Remarks
SCREWS			
P		pan-head screw	binding-head (B) screw for replacement
PWH		pan-head screw with washer face	binding-head (B) screw and flat washer for replacement
PS PSP		pan-head screw with spring washer	binding-head (B) screw and spring washer for replacement
PSW PSPW		pan-head screw with spring and flat washers	binding-head (B) screw and spring and flat washers for replacement
R		round-head screw	binding-head (B) screw for replacement
K		flat-countersunk-head screw	
RK		oval-countersunk-head screw	
B		binding-head screw	
T		truss-head screw	binding-head (B) screw for replacement
F		flat-filister-head screw	
RF		fullister-head screw	
BV		brazer-head screw	

Reference Designation	Shape	Description	Remarks
SELF-TAPPING SCREWS			
TA		self-tapping screw	ex: TA, P 3 x 10
PTP		pan-head self-tapping screw	binding-head self-tapping (TA, B) screw for replacement
PTPWH		pan-head self-tapping screw with washer face	binding-head self-tapping (TA, B) screw and flat washer for replacement
PTTWH		pan-head thread-rolling screw with washer face	binding-head (B) screw and flat washer for replacement
SET SCREWS			
SC		set screw	
SC		hexagon-socket set screw	ex: SC 2.6 x 4, hexagon socket
NUT			
N		nut	
WASHERS			
W		flat washer	
SW		spring washer	
LW		internal-tooth lock washer	ex: LW3, internal
LW		external-tooth lock washer	ex: LW3, external
RETAINING RINGS			
E		retaining ring	
G		grip-type retaining ring	

Sony Corporation

9-950-442-12

© 1981

81C05131-1

Printed in Japan

For Service Manuals Contact
MAURITRON TECHNICAL SERVICES
8 Cherry Tree Rd, Chinnor
Oxon OX9 4QY
Tel: 01844-351894 Fax: 01844-352554
Email: enquiries@mauritron.co.uk