

Audio tape cassettes

P. van der Lely and G. Missriegler

"Speech (or singing) recorded on the cylinder can be reproduced as often as desired, with no weakening of the recording, and the timbre of the voice comes out well . . . The reproduced speech is of great purity and clarity, without annoying background noise. The later instruments reproduce with extraordinary fidelity not only what is spoken and sung, but also what is whispered into the microphone; even the faint sound of breathing can be reproduced."

Since V. Poulsen described his recording of sound on steel wire in these enthusiastic terms in the Annalen der Physik for 1900 (the "cylinder" served for winding on the wire), a great deal has changed in the technique of magnetic recording. In the thirties steel tape was still being used as the recording medium: this had to be played at a speed of two metres per second. However, the development of iron-oxide coated tape and high-frequency biasing led to a rapid increase in the use of magnetic sound recording after the Second World War, and to its wider popularity among the general public. Growing requirements for convenient operation and for effective protection of ever-thinner tapes resulted in the introduction of tape cartridges and cassettes. Among these the Compact Cassette developed by Philips, and now internationally standardized, is outstanding for its convenient shape and small dimensions, and has won a considerable and steadily growing popularity.

Why cassettes?

In the last ten years the use of tape recorders has increased to an extent that at one time would have seemed almost impossible. The popularity of the do-it-yourself sound recording is perhaps only to be compared with the popularity achieved through the years by home movies with 8 mm film.

The technical improvements that have accompanied this development, and are reflected in the products, have taken various directions. They have led not only to a higher quality of reproduction but also, and no less significantly, to simpler operation of the recorders and to a reduction of their volume and weight. This development has also brought the tape recorder into a special field, that of the dictation machine.

Like loading a camera with 8 mm cine film, threading the tape into a tape recorder or dictating machine is a relatively awkward operation for the inexperienced user. And now, that recording equipment is so much more portable, tape often has to be loaded in difficult conditions, e.g. in a moving vehicle. The cartridge or

cassette provides the answer to this problem. It relieves the user of the need to manipulate the tape himself and it offers effective protection.

The protection of the tape is the second important function of the cassette. With the development of thinner tapes, and with the lower tape speeds and narrower sound tracks made possible by improvement of the magnetic properties, it has become imperative to protect the tape from dust and fingerprints. In fact, the use of a cassette is almost essential if the full potentialities of present-day tapes are to be realized [1].

What type of cassette?

In recent years many and various types of audio tape cassettes (often referred to as "cartridges") have appeared on the market. They may be divided into two groups: one-reel and two-reel cassettes.

The one-reel cassette is shown in *fig. 1a*; at the end of the tape there is a catch-piece which is fed into a second, empty cassette after the cassette has been

P. van der Lely is with the Hasselt (Belgium) branch of the Philips Radio, Television and Record-playing Equipment Division; Dipl.-Ing. G. Missriegler is with Oesterreichische Philips Industrie, Werk Wirag GmbH, Vienna.

[1] In view of the two advantages noted here it is not surprising that tape cassettes are also being used for video recording. A video cassette and associated colour video recorder for use in the home are at present under development.

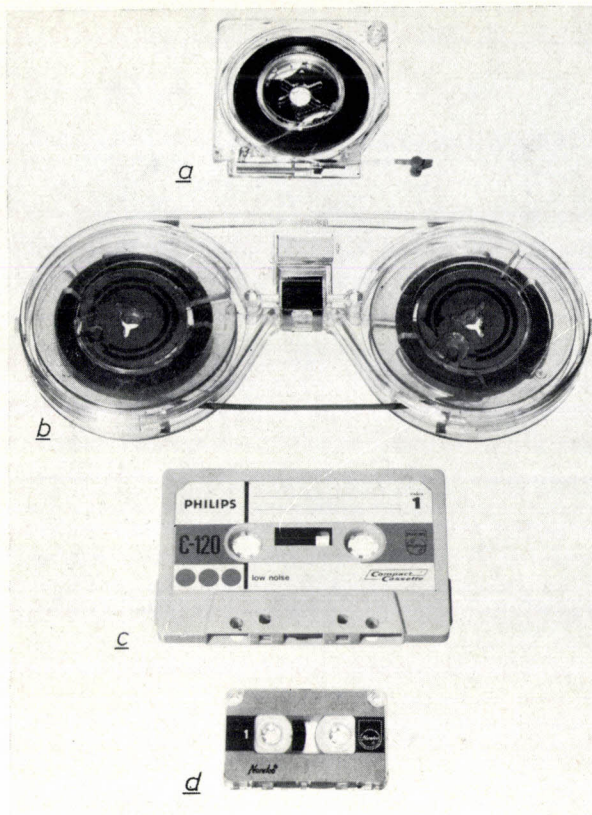

Fig. 1. Various types of audio tape cassette. *a)* One-reel cassette. *b)* Reel-to-reel cassette. *c)* Compact Cassette. *d)* Cassette for the Pocket Memo dictating machine.

loaded in the machine: the empty reel engages with the catch-piece and begins to wind on the tape. The one-reel cassettes are used in dictating machines. In another form of one-reel cassette the tape has an endless loop; since the fast forward winding and rewinding needed for finding a recording quickly is not possible with this kind of cassette, it is only suitable for some applications (announcements, back-ground music).

Unlike the one-reel cassettes the two-reel cassettes contain both a supply reel and a take-up reel. In their original form they were no more than an encapsulation of the two reels of a tape recorder together with the length of tape between them. At first, therefore, they were rather bulky (fig. 1*b*). The trend of development, however, was towards smaller dimensions. At Philips

this development led to the Compact Cassette (fig. 1*c*), which is now very widely used not only for making recordings but also as the "musicassette" with pre-recorded tape [2]. The compactness of the Philips cassette is partly due to the use of flangeless reels with tape which is narrower than usual — 3.81 mm (0.15 inch) instead of 6.25 mm (0.25 inch). But an even more important factor is that the quality of the magnetic tapes has advanced to such a stage that the design of the cassette could be based on a tape speed of only 4.76 cm/s ($1\frac{7}{8}$ inch/s). For general use the Compact Cassette seems to have won the day from the one-reel cassettes, not just because it is compact but also because it can simply be taken from the machine without first having to wind it back, and because the equipment that the cassette fits into does not have to be as complicated.

Even more advanced miniaturization than with the Compact Cassette was possible in the design of a cassette for a pocket dictation machine (fig. 1*d*). Here, since the quality did not have to be so high, there was no need to ensure a constant tape speed by using a drive capstan and pressure roller: the tape is transported directly by the take-up reel, and runs faster as the diameter of the winding on the reel increases. The result was not only a very small cassette but also an extremely compact transport mechanism.

This machine — the Philips Pocket Memo — is shown in fig. 2 beside the smallest of the Philips range of cassette players. Later on we shall look more closely at some of the special features of both these machines, but first we shall look more generally at the magnetic recording process and the relationship between tape speed and quality of reproduction.

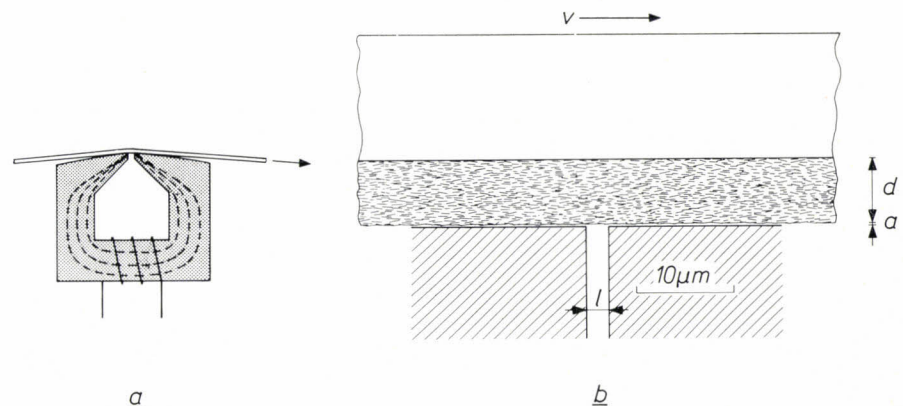

Fig. 3. *a)* The record/playback head has a soft-iron core or yoke with a very short air gap. The tape is in contact with the head at the location of the gap. The magnetization of the tape sends its lines of force partly through the soft-iron core of the head and thus through the winding round the head. *b)* Scale drawing, magnified about 1300 times, of a tape 18 μm thick moving at a speed v past the gap, 2 μm long, of the record/playback head. The tape consists of a plastic base coated with a magnetic layer. d thickness of the magnetic layer. a average distance between tape and head. l length of the gap. The dimensions correspond to those in actual cassette players.

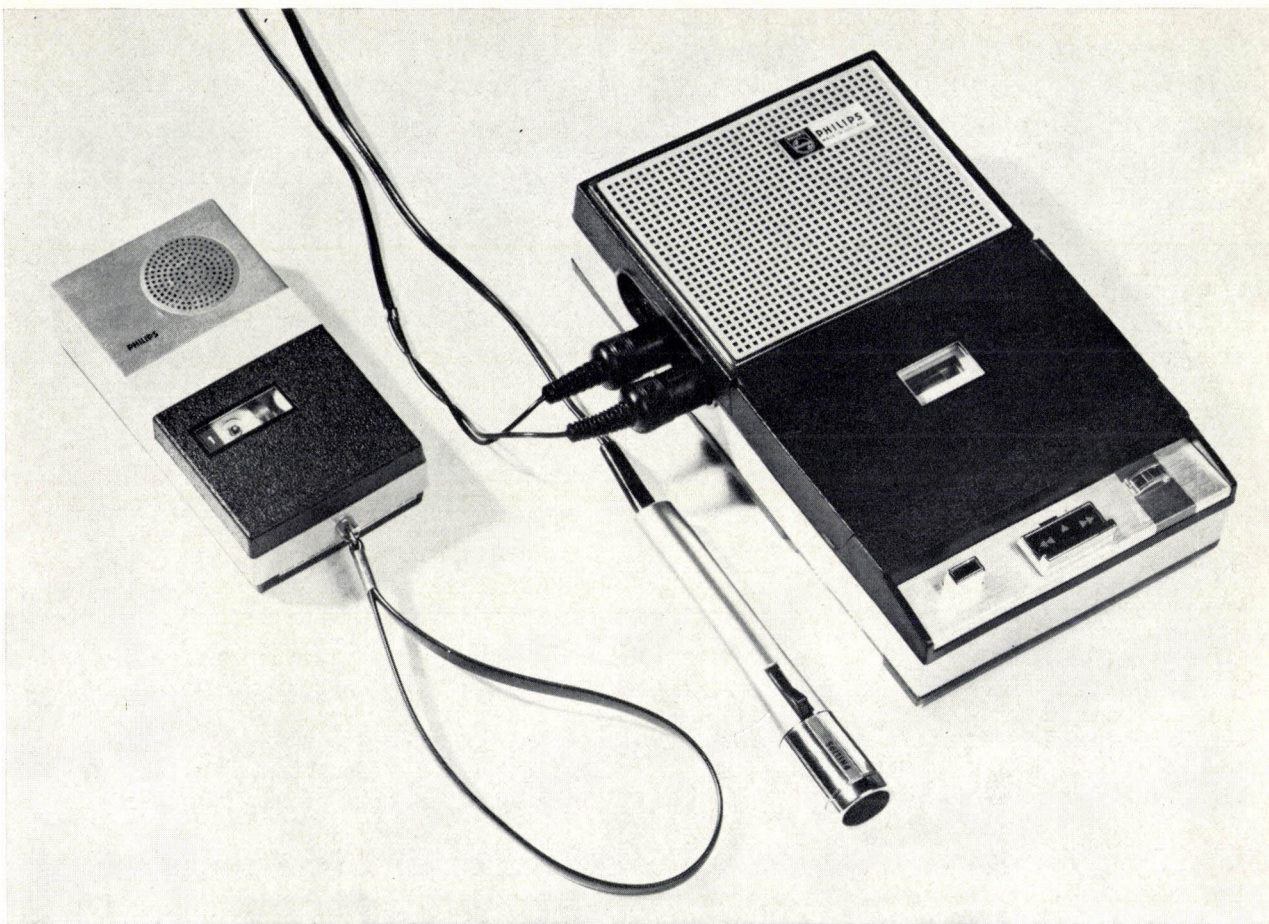

Fig. 2. Left: Pocket Memo dictating machine; right: cassette player with microphone.

Recording and playback at low tape speed

The design of the Compact Cassette is based on a tape speed of 4.76 cm/s. This is low compared with the tape speeds of 9.53 cm/s and 19.05 cm/s commonly used for sound recording, and this means that when a higher frequency f is being recorded the wavelength λ of the periodic magnetization on the tape is small, since $\lambda = v/f$, where v is the tape speed. The recording and reproduction of such small wavelengths sets certain requirements on the recording and playback process. The success achieved in meeting these requirements has been such that in normal use frequencies up to 10 kHz can readily be recorded and reproduced at a tape speed of 4.76 cm/s; a performance that ensures satisfactory reproduction of music.

Within the limited scope of this article the treatment of the recording and playback process which now follows is necessarily highly simplified. There are some advantages in describing the playback process first.

Playback

The requirements to be met by the playback process relate mainly to the geometry of tape and head. Fig. 3a illustrates the way in which a tape moves past a record-

ing or playback head whose soft-iron core has a gap at the location where the tape is in contact with it. Fig. 3b shows a scale drawing, at about 1300 times full size, of a head with a gap length of $2 \mu\text{m}$ ^[3] and a tape $18 \mu\text{m}$ thick, "triple-play" tape. These dimensions apply to the cassette player.

Let us assume that the magnetic layer in fig. 3b is sinusoidally magnetized. The magnetization in and around the gap sends its lines of force partly through the soft-iron core of the head, and hence through the winding around it. The movement of the tape causes the magnetic flux Φ enclosed by the coil to vary, thus

[2] The Compact Cassette has been internationally standardized: IEC Publication 94, Addition 1. In addition to its use for sound recording, the Compact Cassette is also beginning to be used for recording digital signals; for program input in smaller computers and for use in cash registers it can be an improvement on the punched tape. These applications require a somewhat modified construction, and sometimes cassettes are used that have been comprehensively inspected for "drop-outs" (momentary interruptions of the signal), which cause more of a nuisance in digital recording than in sound recording. Preparations for the standardization of digital cassettes have reached an advanced stage.

[3] It is customary to call the dimension of the gap in the direction of tape travel the "length", although it is much smaller than the dimension perpendicular to the plane of the drawing in fig. 3, which is called the "width".

inducing in the coil a voltage E which is equal to $-Nd\Phi/dt$ (N being the number of turns). If we represent the flux Φ , which varies sinusoidally with time t , by $\Phi = \Phi_0 e^{j\omega t}$, where $\omega = 2\pi f$, then we may write

$$E = -N \frac{d\Phi}{dt} = -Nj\omega\Phi. \quad (1)$$

We see that the amplitude of E increases linearly with the frequency f . Thus, each time the frequency doubles the level of E increases by 6 dB. This 6 dB increase per octave is represented by the straight line A in *fig. 4*.

is illustrated by curve B of *fig. 4*. If the wavelength or an integral multiple of it is approximately equal to the gap length, then there is no transfer at all. In practice the minimum wavelength is taken to be $2l$, at which the gap loss is 5 dB. In the cassette player of today the gap length is $2 \mu\text{m}$. The limiting wavelength is thus $4 \mu\text{m}$, which corresponds to an upper cut-off frequency of 12 kHz.

In addition to the gap losses, attenuation occurs at short wavelengths because the tape is not in complete contact with the head but is displaced from it by an

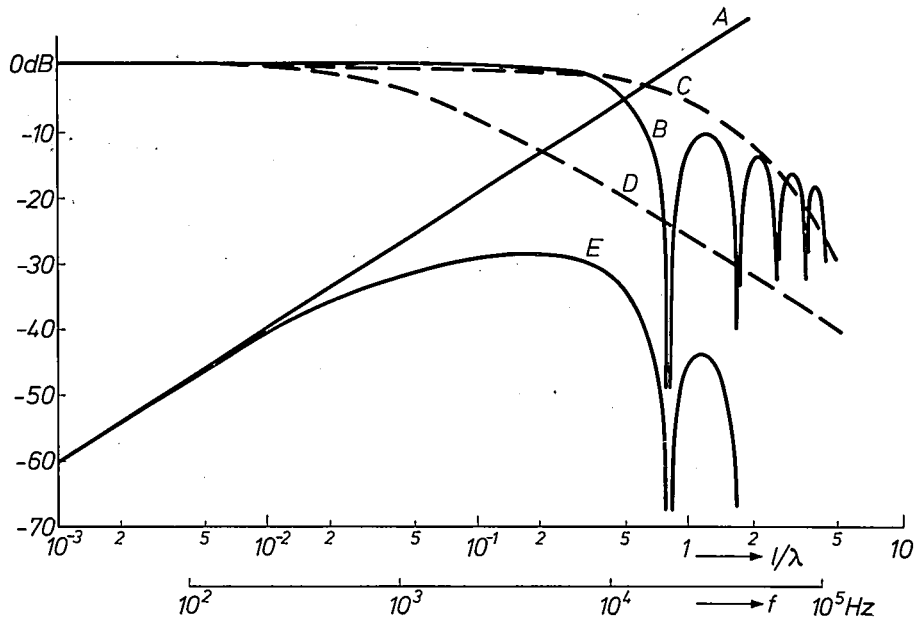

Fig. 4. The frequency characteristic of the playback process is determined by a number of effects. With a constant magnetic flux through the playback head the induced voltage at the terminals of the head increases linearly with the frequency f (curve A). The flux through the playback head drops to zero, however, when the frequency is so high that the wavelength λ of the magnetization on the tape or an integral multiple of it is approximately equal to the gap length l (curve B). Furthermore, with rising frequency the loss increases, partly because there is a certain spacing a between head and tape (curve C) and partly because at higher frequencies a decreasing part of the thickness d of the magnetic layer contributes to the output (curve D). The addition of all these losses results in the frequency characteristic E . With certain simplifying assumptions the curves were calculated for a tape speed of 4.76 cm/s, $l = 2 \mu\text{m}$, $a = 0.2 \mu\text{m}$, and $d = 6 \mu\text{m}$, i.e. values that are normally encountered with cassette recorders.

We shall use this straight line as the basis for calculating the frequency characteristic of the playback process. In practice it is only at low frequencies that any approximation to this characteristic is found [4]: at high frequencies there are losses because of certain geometrical factors.

To begin with, there are the gap losses. Clearly, the detailed pattern of the tape magnetization between the beginning and end of the gap cannot be observed by the playback head. The wavelength of the magnetization on the tape must therefore be large compared with the gap length l . The nearer the wavelength approaches to the gap length the smaller the recorded signal; this

average distance a . To calculate this attenuation we start with the flux which is induced in the head by a thin layer of the tape of thickness dy and located at a distance y from the head; this flux is proportional to $e^{-2\pi y/\lambda}$ [5]. If the whole magnetic layer of the tape is uniformly magnetized — this is not in fact true but we shall permit ourselves the assumption to make things easier — then the total flux Φ through the head is proportional to the average value of this function over the thickness d of the tape, i.e. proportional to

$$\frac{1}{d} \int_a^{d+a} e^{-2\pi y/\lambda} dy = \frac{\lambda}{2\pi d} e^{-2\pi a/\lambda} (1 - e^{-2\pi d/\lambda}). \quad (2)$$

The factor $e^{-2\pi a/\lambda}$ represents the attenuation due to the distance a ; this attenuation is 54.5 dB per wavelength distance between tape and head. In practice the distance is 0.1 μm to 0.3 μm , which, at a wavelength of 4 μm , corresponds to an attenuation of 1.4 dB to 4.1 dB. This "spacing loss", calculated for a spacing a of 0.2 μm , is given by curve *C* of fig. 4.

The factor $(\lambda/2\pi d)(1 - e^{-2\pi d/\lambda})$ indicates that as the wavelength becomes shorter the contribution to the output signal comes more and more from the magnetization close to the tape surface. There is a "thickness loss", and its magnitude appears in fig. 4 from curve *D* for the tape-head configuration of fig. 3*b*, i.e. for a layer thickness of 6 μm .

If at each frequency we add up the three different sorts of losses mentioned above and then subtract the sum from the theoretical 6 dB/octave characteristic *A*, we obtain the curve *E* of fig. 4. This curve gives the frequency response of the playback process, and is valid for the assumption of homogeneous magnetization over the whole thickness of the tape. It is evident that the cut-off frequency is determined primarily by the gap losses (curve *B*). One of the related problems with a mass-produced product like the cassette player is that of making the very narrow gaps in the heads accurately to size and with properly finished edges; an increase of 1 micron in the effective gap length could bring the theoretical cut-off frequency mentioned above from 12 kHz to 8 kHz.

There is another possible cause of losses at high frequencies, and this is also significant because the cassette recorder is a mass-produced product. We have tacitly assumed in our analysis that the tape is magnetized by a recording head in which the width of the gap, like that of the playback head, is perpendicular to the direction of travel of the tape, i.e. perpendicular to the plane of fig. 3. The correct setting is made as accurately as possible by individual adjustment of what is usually called the "azimuth" of the head. A difference in angle α between the recording and reproducing gaps gives an effective lengthening of the gap and additional losses at short wavelengths. These losses, again expressed in dB, are given by

$$20 \log_{10} \frac{\sin(\pi w \tan \alpha/\lambda)}{\pi w \tan \alpha/\lambda} \text{ dB}, \quad \dots \quad (3)$$

where w is the width of the sound track. A plot of (3) as a function of frequency gives a curve similar to curve *B* of fig. 4. In monaural recording on a cassette tape the track width is 1.5 mm; a 3 dB attenuation of the cut-off wavelength of 4 μm occurs here at an azimuth error α of only 4'. Regular adjustment of the azimuth of the head is obviously not possible in cassette machines, and therefore azimuth errors may cause sig-

nificant deterioration of the frequency characteristic. They are mainly significant when a tape is played back on a different machine from the one on which the recording was made.

Recording

To obtain a linear relationship between magnetization and signal current during the recording process, a high-frequency a.c. current is passed through the recording head together with the signal current.^[6] The amplitude of this bias current is so high as to cause the magnetic field at the gap to periodically exceed the coercivity of the magnetic material in the tape; its frequency is several times higher than the audio frequencies to be recorded. The tape acquires its remanent magnetization when the tape has passed the gap and traverses a zone in which the peak value of the magnetic field has decreased to a value exactly equal to the coercivity (fig. 5). This recording zone has a certain extent, partly because all the magnetic particles in the tape do not have exactly the same coercivity. It is desirable that the instantaneous value of the signal should not change much during the time that a point of the tape passes through the recording zone, in other words that the

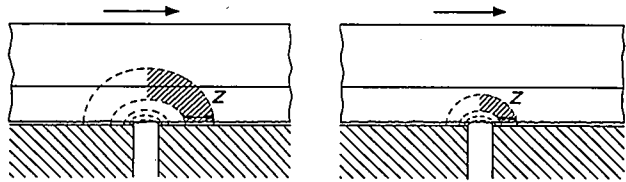

Fig. 5. The magnetization of the tape takes place in a zone *Z*, in which the magnetic field strength has decreased to the coercivity of the tape. The path through this zone is longer at a high bias current (left) than at a small bias current (right).

extent of the recording zone should be small with respect to the wavelength to be recorded. The width of the recording zone increases with the magnitude of the bias current (fig. 5). For short wavelengths it is therefore best to use a smaller bias current. The recording zone then contracts around the gap and no longer covers the full thickness of the magnetic layer. This is no disadvantage, however, since as we saw above at short wavelengths the contribution to the output signal

[4] Unless the wavelength on the tape is much larger than the length of tape in contact with the head; this is not the case for the cassette player, where the wavelength at 50 Hz is only about 1 mm.

[5] R. L. Wallace, Jr., The reproduction of magnetically recorded signals, *Bell Syst. tech. J.* 30, 1145-1173, 1951.

[6] The idea of the high-frequency bias current seems to have had three different originators; see W. K. Westmijze, *Studies on magnetic recording*, Thesis, Leyden 1953. Its linearizing action is dealt with by the same author in: The principle of the magnetic recording and reproduction of sound, *Philips tech. Rev.* 15, 84-96, 1953/54.

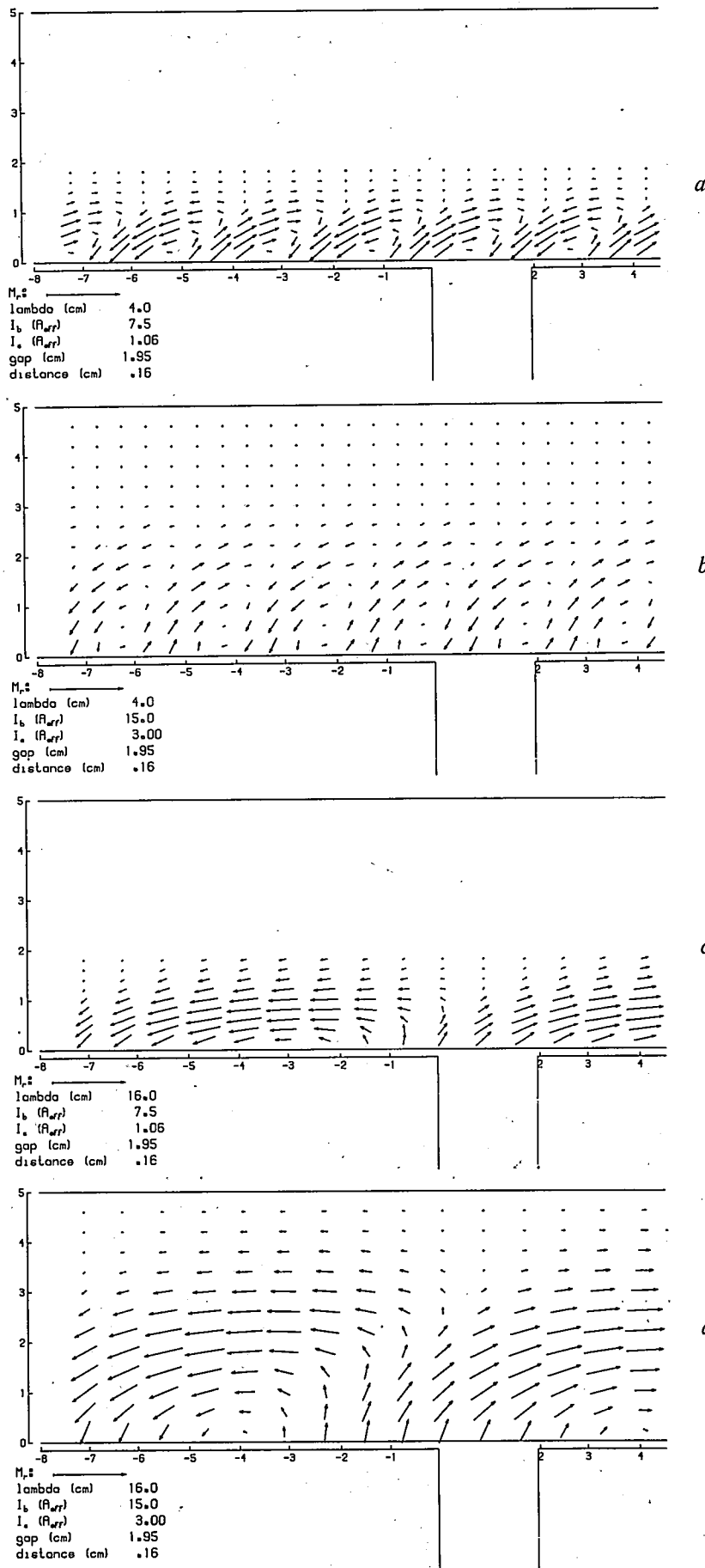

Fig. 6. The magnetization inside a magnetic tape, measured on a 5000 : 1 scale model. The magnitude of the magnetization is expressed by the length of the arrows; for comparison the remanence M_r of the magnetic material is also given. The gap in the head is shown beneath the longitudinal section of the magnetic layer in the position which it took up at one of the instants when the signal current passed through zero. *a*) Short wavelength and low bias current I_b . *b*) Short wavelength and high bias current; although the signal current I_s is three times greater than in (*a*), the remanent magnetization is lower. *c*) Long wavelength and low bias current; only part of the layer thickness is magnetized. *d*) Long wavelength and high bias current; almost the entire layer is magnetized.

comes only from the surface of the magnetic layer. On the other hand at low frequencies, i.e. at long wavelengths it is useful to magnetize the layer over its whole thickness, and for this purpose a higher bias current is desirable.

The effect of the bias current on the recorded remanent magnetization at long and short wavelengths is illustrated in *fig. 6*, obtained from measurements on a scale model of the magnetic recording process magnified 5000 times [7]. For a short wavelength a comparison of *fig. 6b* and *fig. 6a* shows that doubling the bias current I_b gives a smaller remanent magnetization even though the signal current I_s is made three times as large. In this case the magnitude of the magnetization finally impressed on the tape is determined not only by the signal current but also by the bias current. At long wavelengths the situation is different; in *fig. 6c,d* it can be seen that when the wavelength is increased by a factor of four the remanent magnetism is the same both for high and low bias current, though with the high bias current a greater depth of the layer is magnetized. At this wavelength the result is an increased output voltage on playback.

The relative levels at which high and low frequencies are recorded on the tape therefore depend partly on the magnitude of the bias current. This has to be taken into account when devising the corrections to the frequency response that will give the correct relative levels on playback; more will be said about this when we describe the cassette player on page 88. In any case the choice of the bias current has in practice to be a compromise between what is desirable for high frequencies and what is desirable for low frequencies [8]. The compromise adopted for the cassette player rather favours the high frequencies; the bias current is lower than in normal sound recording.

When the magnetic coating of the tape is saturated, the maximum output level of the tape has been reached. Exceeding this level will cause non-linear distortion. When making a recording the aim is to magnetize the tape to a level at which the loudest passages do not quite reach the maximum output level; this is often defined as the signal amplitude at which the third harmonic caused by non-linear distortion of the fundamental reaches 5% of the amplitude of the fundamental. This definition applies for low frequencies. At high frequencies it is not usually possible to drive the tape into saturation. This is because an increase of the signal current, like an increase of the bias current, makes the recording zone broader, so that the recorded signals are smaller for the short wavelengths, which are of the same order of magnitude as the width of the recording zone or less. At short wavelengths, therefore, the impressed magnetization does not increase linearly with

the signal current but reaches a maximum. This deviation from linearity at high frequencies is the cause of non-linear distortion. At high frequencies, also, the permissible distortion determines the maximum signal level that can be recorded on the tape, but in this case it is not connected with magnetic saturation. At a higher bias current the deviation from linearity will start at lower signal currents, which means that the maximum undistorted output level of the tape is lower.

The tape

Audio tapes are made by coating a plastic base with a thin layer consisting of a suspension of magnetic material in a volatile solvent, mixed with an organic binder. After drying, the magnetic material — particles of iron oxide or nowadays chromium dioxide — remain on the base embedded in the binder. The following four factors have contributed significantly to the improvement in tape quality.

1. Improvement in the shape of the particles, giving the material better magnetic properties;
2. A more uniform distribution of the particles in the binder;
3. The use of binders with better resistance to wear;
4. Finishing treatment of the surface to make it smoother.

Originally cubic iron-oxide particles were used (*fig. 7a*). An advance came with the use of smaller, needle-shaped particles, about 1 μm long and 0.2 μm thick (*fig. 7b*). Smaller particles are important because the average size of a particle should preferably be less than half the shortest wavelength to be recorded. The shape anisotropy of the needles gives a greater coercivity; moreover, needle-shaped particles can be oriented parallel to the direction of travel of the tape while the coating is still wet. This treatment increases the remanent magnetization of the tape and thus gives a higher output voltage on playback.

Since the particles are magnetic, they tend to cluster together in the binder while it is still wet. This effect ("clumping") makes it difficult to obtain a homogeneous distribution. During the preparation, which takes place at high temperature (about 350 °C), the iron-oxide particles are sometimes found to be sintered together. This leads to a high noise level and a rough surface, which increases the average spacing between tape and head and consequently increases the spacing

[7] D. L. A. Tjaden and J. Leyten, A 5000: 1 scale model of the magnetic recording process, *Philips tech. Rev.* 25, 319-329, 1963/64.

[8] There is no need to be content with a compromise if low and high frequencies are recorded one after the other, each under its own optimum conditions, on the same sound track: E. de Niet, K. Teer and D. L. A. Tjaden, *Magnetic recording of audio signals at low tape speeds*, 4th Int. Congress on Acoustics, Copenhagen 1962, paper No. N 11.

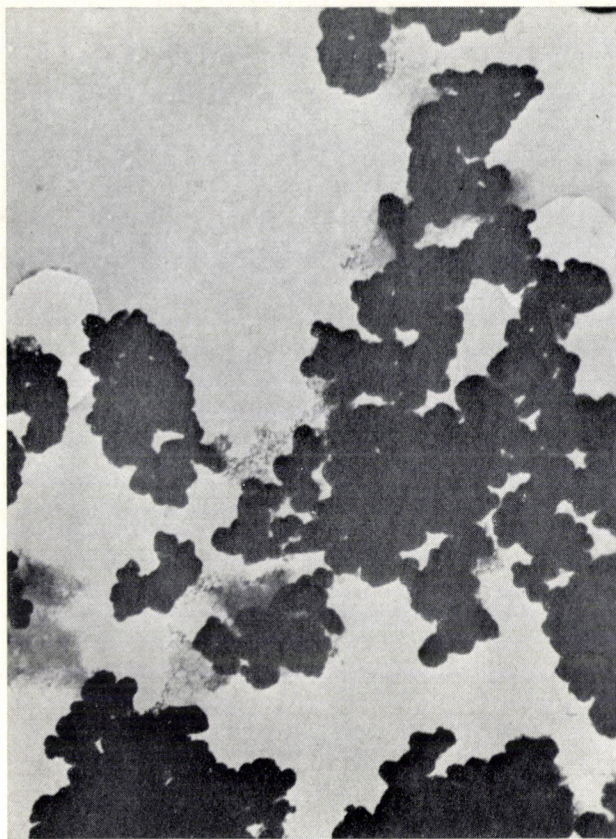

a

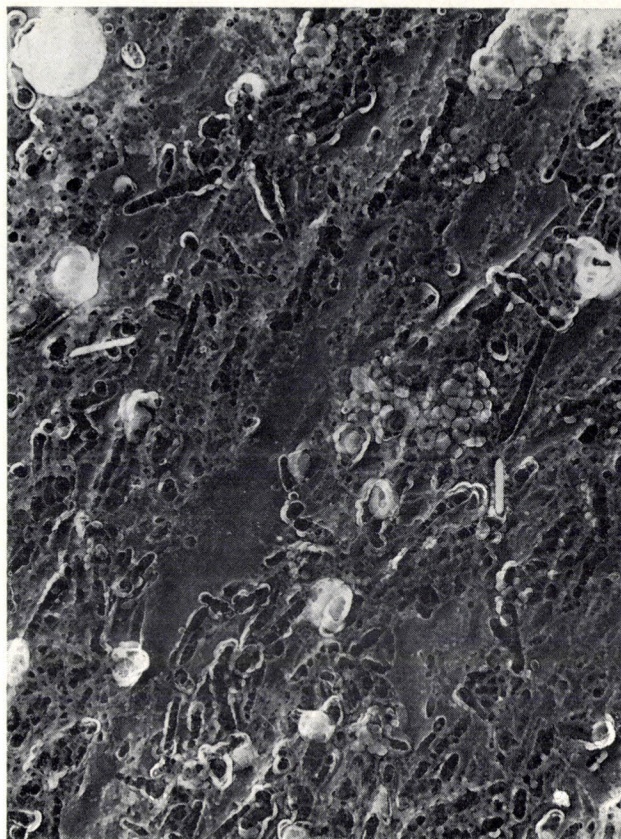

b

loss. Clumping can be countered by adding dispersion stabilizers to the suspension. These are organic substances which adhere to the iron-oxide particles. Nowadays more effective dispersion stabilizers are available, and in addition there are other effective methods of dispersion. Modern tapes are therefore more homogeneous and have a smoother surface.

A smoother surface gives a lower spacing loss. Another improvement in this respect comes from the use of binders which have better resistance to wear, so that there is less contamination of the head from abrasion of the magnetic layer. Moreover most tapes are now given a finishing treatment to make the surface smoother. This is a calendaring process, in which the tape is passed between heated rollers under pressure.

Tapes with chromium dioxide have particularly good properties. This is mainly because the chromium-dioxide needles are more uniform in size than the iron-oxide needles and also because they do not sinter together during preparation (fig. 7c). There is no sintering since, unlike the iron oxide, the chromium-dioxide particles are prepared in a wet chemical process at ordinary temperatures. As they do not form clusters to the same extent, the chromium-dioxide needles can also be better oriented, giving a higher remanence.

Apart from the improvements in the magnetic coat-

ing, there have also been important improvements in the base. The oldest tapes, intended for a tape speed of 76.2 cm/s, were subjected to considerable mechanical stress and the paper base had therefore to be very thick; the thickness of these "standard" tapes was 54 μm . The availability of stronger base materials (in the order of their appearance: cellulose acetate, polyvinyl chloride and polyester) and the reduction of tape speeds made it possible to introduce thinner tapes (see Table I). Tapes with thicknesses of 12.5 μm and 9 μm , which are the latest development in this field, are exclusively for use in cassettes; since the bias current in cassette recorders is lower, the magnetic coating of these tapes is thinner. The greater flexibility of thin tapes gives better contact between tape and head.

An important aspect of the improvement in tapes is

Table I. Stages in the development of thinner audio tapes.

Total thickness (μm)	Thickness of magnetic layer (μm)	Name	Type designation of cassette
54	15	standard tape	—
35	10-11	longplay tape	—
25	10-11	double-play tape	—
18	6	triple-play tape	C 60
12.5	3-4	—	C 90
9	3-4	—	C 120



c

that it has led to an increase in the density of the information that can be recorded on magnetic tape. Contributory factors here have been the introduction of thinner tapes, improved characteristics at short wavelengths, higher remanence and improved noise characteristics; the last two factors have made narrower sound tracks possible. A reel with a diameter of 18 cm, for example, can hold 360 metres of standard tape. In the old days, recording over the full width of the tape and using a tape speed of 38.1 cm/s, which was then necessary for high quality, the playing time was 15 minutes. The same sound quality can now be obtained with a four-track recording and a tape speed of 9.5 cm/s. The same 18 cm reel can now take 1080 metres of triple-play tape and thus at this speed gives a playing time of 4×180 minutes. This means a 48-fold increase of the information per unit volume.

With such a long playing time on one reel of tape it becomes difficult to find a particular passage or programme; the reel with four-track tape has become a relatively inaccessible carrier of information. Here again the cassette provides a welcome solution, since it can be taken out of the machine without first having to wind the tape back, thus offering increased information density in a smaller package.

[9] L. F. Ottens, *The Compact Cassette for audio tape recorders*, J. Audio Engng. Soc. **15**, 26-28, 1967.

Fig. 7. Electron photomicrographs of the magnetic layer of *a*) a tape with cubic iron-oxide particles, in common use about 20 years ago; *b*) a tape with needle-shaped iron-oxide particles as commonly used today, and *c*) a recently marketed tape with chromium-dioxide particles. The magnification of all three photomicrographs is $14\,500\times$. Those in (*b*) and (*c*) were made by the replica technique; in (*c*) the white bars are chromium-dioxide needles that have stuck to the replica, while other chromium-dioxide needles have only left impressions in the replica.

The Compact Cassette

We shall now deal in somewhat more detail with the design of the Compact Cassette [9]. We have already mentioned that it was designed for a tape width of 3.81 mm and for a tape speed of 4.76 cm/s. Two sound tracks are recorded on the tape, one in the forward direction and one in the reverse direction. Depending on the thickness of the tape used, the cassette gives a playing time of 2×30 minutes, 2×45 minutes or 2×60 minutes; the three types are designated by the numbers C 60, C 90 or C 120 (see Table I). In stereophonic equipment the 1.5 mm wide sound tracks are each subdivided into two tracks of 0.6 mm, with a separation of 0.3 mm, for the left-hand and right-hand channels (*fig. 8*). This division of the tracks makes monaural and stereo recordings fully compatible. Crosstalk from one channel to the other is minimal; the channel separation

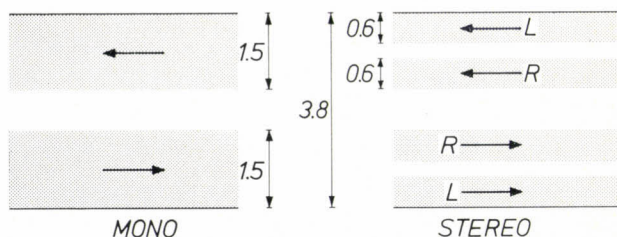

Fig. 8. Arrangement of the sound tracks on a cassette tape. *L* left-hand channel, *R* right-hand channel.

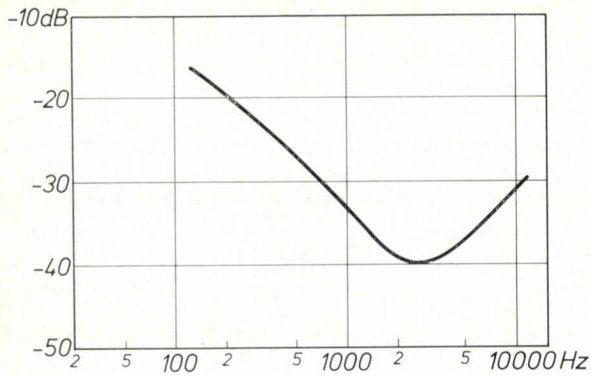

Fig. 9. Separation between the two channels for playback of a stereophonic programme on a Compact Cassette.

wound on to hubs 1 and fastened to them with a clamping-piece 2, shaped in such a way as to preserve as far as possible the circular shape of the hub. A lining 3 inside the cassette holds the tape in place at both sides. To keep the power required for fast winding as low as possible, the tape is not threaded over fixed guide spindles but over rollers 4. When the cassette is loaded into the device and tape transport is switched on, the erase head 5 and the record/playback head 6 are brought into contact with the tape through openings in the cassette; at the same time the pressure roller 7 is pressed against the driving spindle or capstan 8. Each cassette contains high-permeability screening 9, which

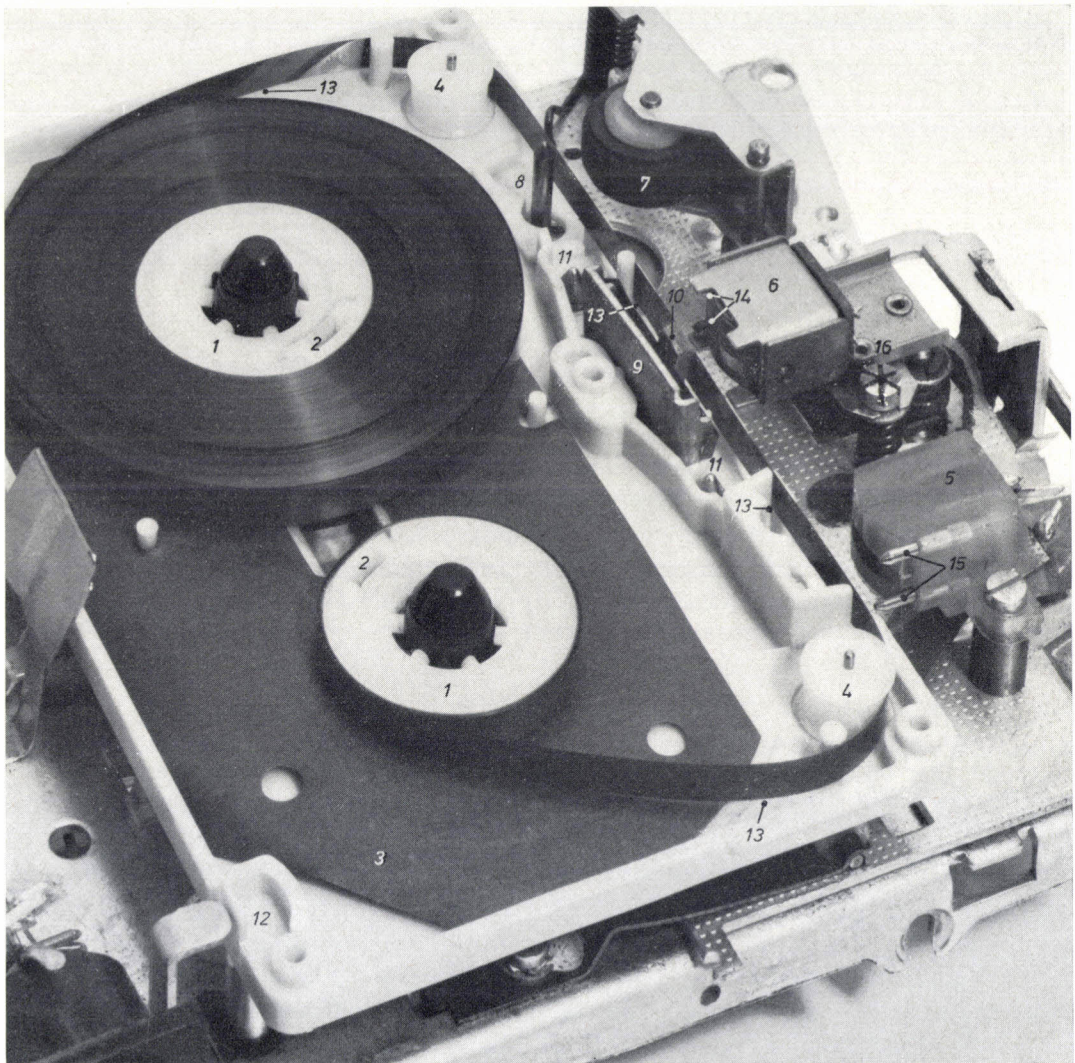

Fig. 10. View inside a cassette in a cassette player. 1 hubs. 2 clamping piece. 3 lining. 4 rollers. 5 erase head. 6 record/playback head. 7 pressure roller. 8 capstan. 9 high-permeability screening. 10 felt pressure pad. 11 reference holes and pins. 12 recording lock. 13 support points for tape transport. 14 tape guides. 15 tape guides. 16 screw for adjusting azimuth.

is presented in *fig. 9* as a function of frequency. The channel separation is more than sufficient to give an unimpaired stereo effect and is in fact greater than the separation on stereo gramophone records.

Fig. 10 shows the interior of a cassette. The tape is

connects up with the screening in the cassette player to protect the head against stray fields, and a felt pressure pad 10, which presses the tape against the head with a force of 0.1 N to 0.2 N. Two reference holes 11 correspond to the two locating pins in the cassette player; a

spring pushes the cassette towards the heads. A recording can be protected against accidental erasure by breaking the lip of the recording lock 12; there is one lock for each track. A pawl in the cassette equipment then falls into the hole vacated by the lip and prevents recording. At both ends of the tape there is usually a thicker polyterephthalate strip which takes the strain when the tape suddenly stops at the end of fast forward winding or rewinding.

A few support points 13 help to guide the tape in the cassette. To give more accurate guidance of the tape past the head, the capstan draws the tape between two accurately aligned guides 14 fitted to the housing of the record/playback head. There are two similar guides 15 on the erase head. We have already mentioned the importance of accurate guidance of the tape in avoiding azimuth errors. The azimuth of the record/playback head is individually adjusted in every cassette player by means of an adjusting screw 16.

Philips cassette equipment

Transport mechanism

The transport mechanism of a cassette recorder or player has to feed the tape over the record/playback head at an accurately constant speed. Fluctuations in this speed, due for example to non-circularity of rotating parts, result in fluctuations of pitch in the reproduced music, which can be very annoying and are referred to as "wow" or "flutter". Apart from feeding the tape at a constant speed, the transport mechanism for battery equipment also has to take very little current. In addition the mechanism must be accommodated in a small volume of prescribed shape.

The tape is transported by the capstan, with a rubber roller pressing the tape against the capstan. For uniform tape feed it is of prime importance that the motor driving the capstan should run at a constant speed, which does not decrease when the battery voltage drops or when the mechanical load increases. During playback the load does increase since the radius of the roll of tape becomes smaller as it unwinds while the braking torque acting on it remains constant; this causes an increase in the tension on the tape. To keep the motor speed constant, Philips cassette machines contain an electronic control circuit (fig. 11). This circuit keeps the tape speed constant to within 0.5% during varying load, and continues to operate as long as the battery voltage, which is 7.5 V nominal, has not dropped below 5 V.

In the control circuit the motor M forms one of the branches of a bridge circuit whose out-of-balance voltage is applied across the emitter-base junction of a transistor $Tr 1$. This transistor drives a second one, $Tr 2$, which determines the current through the

whole bridge. If the motor speed changes, the opposing voltage induced in the motor coil changes in proportion to the speed, and this change reacts on the balance of the bridge in such a way as to oppose the speed variation. This is accompanied by a change in the current through the motor and hence by a change in the voltage drop across the ohmic resistance in the motor. The resistor R_1 is given a value such that the voltage drop across it balances the drop across the ohmic resistance of the motor. The copper-wound resistor R_{Cu} has the correct temperature dependence to compensate various temperature effects in the motor and semiconductors.

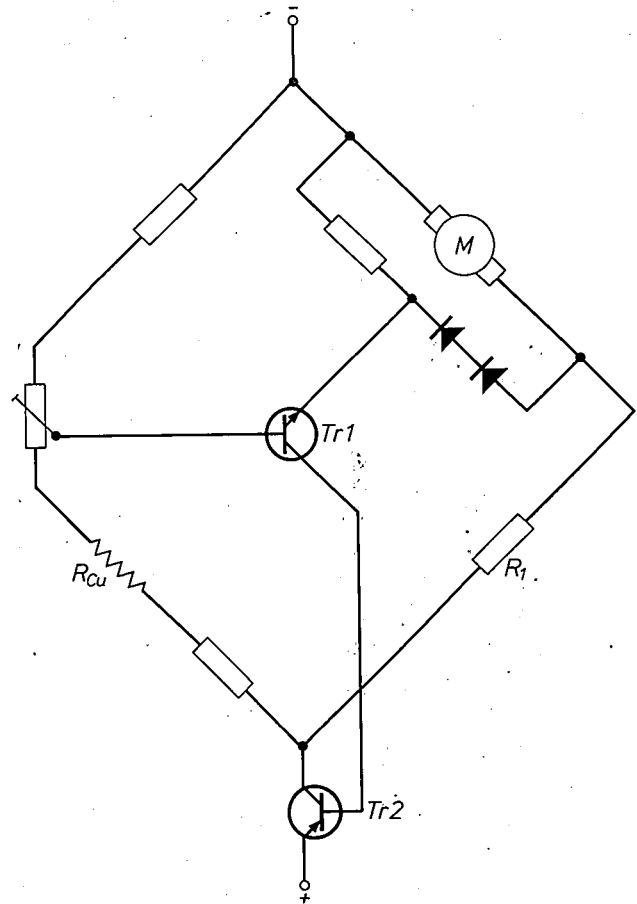

Fig. 11. Electronic control circuit which keeps the speed of motor M constant with decreasing battery voltage and varying load. A decrease in motor speed causes a decrease in the induced voltage generated in the motor; this puts the bridge circuit out of balance, causing transistor $Tr 1$ to drive transistor $Tr 2$ in a direction such that the current through the bridge circuit increases, and with it the motor speed. The temperature dependence of the copper-wound resistor R_{Cu} compensates the sum of a number of temperature effects in the motor and semiconductors.

A motor speed control system prevents slow variations in tape speed, but not the faster variations that cause wow and flutter.

To suppress these faster variations a flywheel is fitted to the capstan of a tape device. Because of the limited space available in the cassette transport mechanism, the flywheel can only be fairly small in diameter (see fig. 12), but this is compensated by using a thin, fast-running capstan. This has the disadvantages that the capstan has to be machined even more accurately and

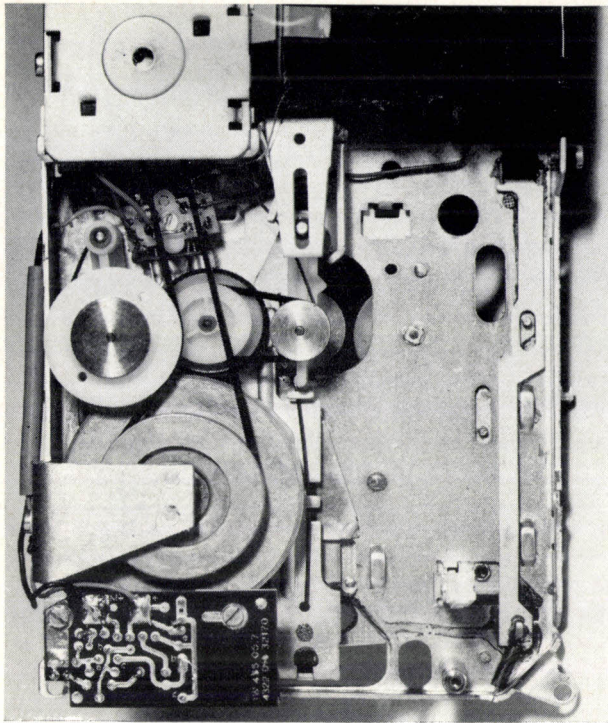

Fig. 12. View of the cassette transport mechanism from below.

that it may bend under the lateral force exerted by the pressure roller. Misalignment of the capstan affects the tape feed, causing effects such as azimuth error. In Philips cassette equipment the compromise taken is to make the capstan diameter 2 mm and the speed about 7.5 revolutions per second.

The capstan with flywheel is driven by a rubber belt and pulley system. This gives better damping of any fast ripple in the speed of the motor than a system of intermediate pulley wheels. Ripple of this kind can occur because the rotating rotor tends to "cling" at certain angular positions. Another advantage of such a drive system is that it gives greater freedom in the layout of a tape-transport mechanism. For these advantages we are prepared to accept the disadvantages of possible flutter due to variations of belt thickness or slipping of a stretched belt. Precision-ground belts are used that have thickness variations of less than 2%. The same belt drives both the flywheel and the take-up reel, but the take-up reel is driven via a slipping clutch which is needed because the speed of revolution of the take-up reel decreases as it fills up with tape.

To measure the magnitude of the flutter, which consists of frequency modulation of the tones recorded on the tape, these tones are demodulated. The modulating signal can then be analysed into its constituent frequencies. A frequency analysis carried out in this way for the flutter of a cassette player is shown in *fig. 13*. The four principal frequency components are seen to lie at the rotational frequency of the belt (about 3 Hz), the slip-

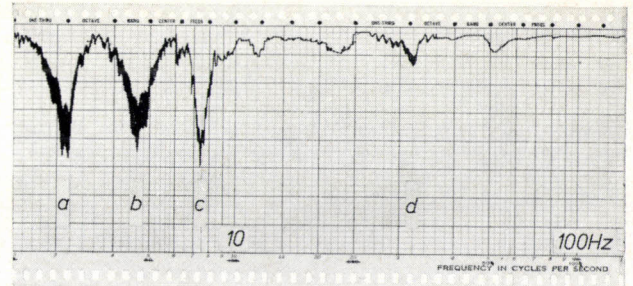

Fig. 13. Frequency analysis of the flutter in a cassette player. The amplitude is marked on the scale from top to bottom. Four frequency components may be observed, originating from the rubber belt (*a*), the slipping clutch (*b*), the capstan (*c*) and the motor (*d*).

ping clutch (4.6 Hz), the capstan (7.5 Hz) and the motor (32 Hz).

The magnitude of the flutter is expressed as the percentage frequency variation of a tone. The annoyance caused by flutter depends on the rapidity of the variations; the most annoying are variations with a frequency in the region of 4 Hz. All frequency components in the flutter are thus not equally troublesome. It is customary to "weight" them against a certain specification, such as the widely used weighting curve (*fig. 14*) laid down in the German standard DIN 45507. For the simple Philips cassette players the flutter, when weighted from this curve, must be no more than 0.4%; more expensive equipment has to meet a stiffer specification.

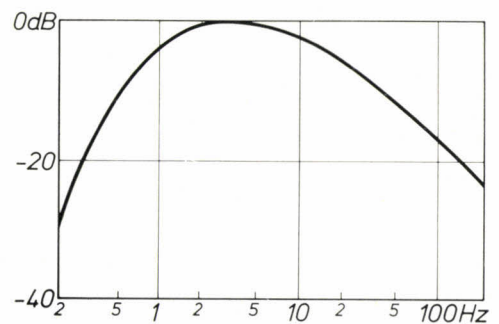

Fig. 14. Weighting curve after DIN 45507; which shows the weighting that the various frequency components of the flutter in a sound recording have to be given in order to express the flutter in a single numerical value corresponding to the degree of annoyance experienced.

Current consumption of the transport mechanism

The tape-transport mechanism in the Philips cassette player takes a current of 75 mA. When the battery voltage has dropped to 5 V, the electrical power supplied to the player is distributed among the components of the mechanism as shown in *fig. 15*. The battery voltage is usually higher than 5 V; the speed control then has an appreciably larger share, because it dissipates the surplus power. The friction in the bearings of

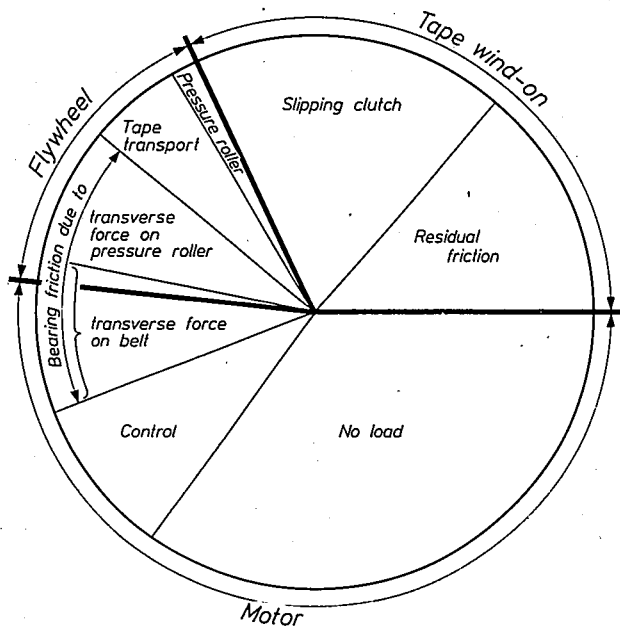

Fig. 15. Distribution of electrical power among the components of the transport mechanism when a tape cassette is played on a Philips cassette player. The fractions of the bearing friction due to the lateral forces originating from the rubber belt and pressure roller are presented separately. The distribution shown here relates to the situation when the battery voltage has decreased to 5 V. At a higher battery voltage the share of the control system is much larger.

motor and flywheel is considerably increased by the lateral forces exerted by the drive belt and the pressure roller; the flywheel bearing friction is in fact almost entirely due to these lateral forces.

Electroacoustic characteristics

The electroacoustic characteristics of a tape player, such as frequency response and signal-to-noise ratio, are determined not only by the characteristics of the tape and the tape geometry (see fig. 4) but also by the processing which the signals presented for recording and reproduction receive in the electronic circuits of the device. The frequency characteristic resulting from the recording and playback process is not usable until it has been corrected (or "equalized") in these circuits. The purpose of the equalization may be given a somewhat wider formulation: to obtain the best signal-to-noise ratio, maximum use must be made at all frequencies of the dynamic range of the tape, and the replay output characteristic must be flat within the widest possible range of frequencies.

The dynamic range of the tape is not identical for all tapes and at higher frequencies it also varies with the bias current (see page 83). To avoid a situation in which every manufacturer introduced his own corrections, and tapes would not necessarily be interchangeable, an international standard has been laid down for

the variation of the magnetization on the tape with frequency, for a constant signal at the input of the recording amplifier [10]. The magnetization is defined in this standard as the magnitude of the "surface induction", which is the flux density at right angles to the surface of the tape when the tape is moved along against an ideal reproducing head. Different surface-induction frequency curves have been laid down for the various standard tape speeds, and curve *M* in fig. 16 is an example for the tape speed of 4.76 cm/s. In practice the playback amplifier is equalized with the aid of a reference tape, taken to be magnetized in accordance with this standard; the amplifier is given a frequency characteristic such that when the reference tape is played, a virtually frequency-independent signal amplitude appears at the output. The replay characteristic of the Philips cassette players is given by curve *P* of fig. 16.

When the surface induction is the same at different frequencies, then — neglecting for a moment the losses indicated in fig. 4 — the induced voltage at the terminals of the playback head is also the same at these different frequencies. This explains why the playback characteristic *P* in fig. 16 is very like the mirror image of the magnetization curve *M*. The standard curve *M* thus determines to a large extent the playback characteristic of a cassette player; at high frequencies, however, *P* rises steeply to offset the gap losses occurring on playback (fig. 4, curve *B*), and this high-frequency equalization may differ from one type of cassette player to another.

What frequency characteristic should we now give to the recording amplifier to ensure that the overall frequency characteristic is flat when a tape is played back through the playback amplifier corrected in the manner described? The answer to this question depends on how large we decide to make the bias current. We have explained on page 83 that the relative levels at which low and high frequencies are recorded depend on the magnitude of the bias current, and that the maximum output level of the tape at high frequencies also depends on the bias current. With a higher bias current the high fre-

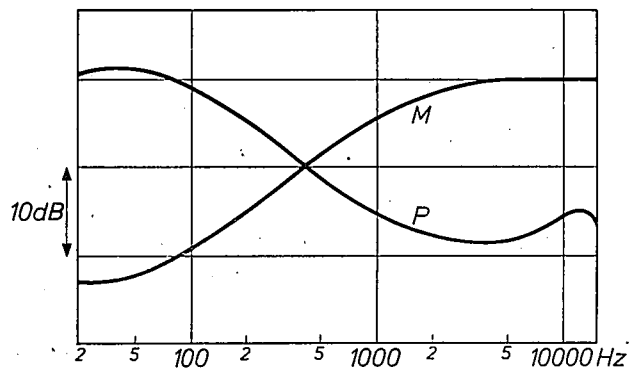

Fig. 16. *M* internationally standardized curve [10] showing the variation of tape magnetization with frequency for constant voltage at the input of the recording amplifier; the curve relates to a tape speed of 4.76 cm/s. *P* frequency characteristic of the playback amplifier in the Philips cassette player.

[10] IEC Publication 94.

frequencies give a smaller recorded signal, and at the same time the maximum undistorted output level of the tape decreases at high frequencies. On the other hand, we also saw that good recording of the low frequencies requires a relatively high bias current. If we are to meet this requirement as well we shall have to compensate the attenuation of the high frequencies by an appropriate high-frequency "lift" upon recording. This can in fact be done without exceeding the maximum output level of the tape, since the energy content of the higher frequencies (higher than 2 kHz) in an average music signal is smaller than the energy content of the lower frequencies. The aim, however, is not only to obtain an optimum frequency response but also to achieve an optimum distortion-free modulation of the tape. We try to achieve this by setting the bias current to a value at which the low-frequency and high-frequency signals in an average music signal both approach the limit for distortion-free modulation on the tape to about the same extent after the high-frequency compensation in the recording amplifier. If a signal exceeds the permissible amplitude, then there will be simultaneous distortion of both low and high frequencies. If the bias current is higher than this optimum value, more high-frequency compensation will be needed; this conflicts, however, with the reduced modulation limit of the tape and the high frequencies are the first to show distortion. At too low a bias current the low frequencies become distorted first.

The term "average music signal" used here suggests that practical experience must also have a say in the choice of bias current and high-frequency compensation. In the Philips cassette player the recording amplifier has been given the frequency characteristic shown by curve *R* of fig. 17. This lifts not only the high frequencies but also the frequencies below 200 Hz. This corresponds with the shape of curve *M* in this region, and the object is to improve the ratio of the signal to

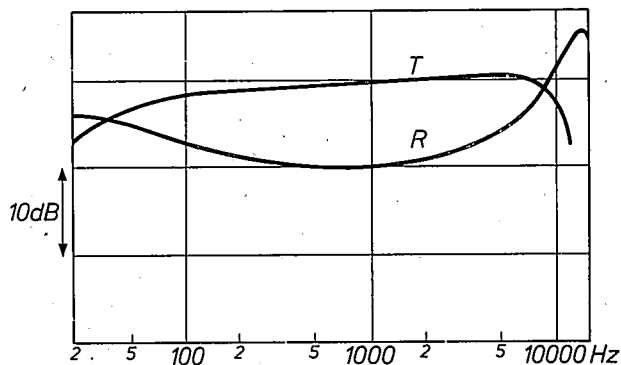

Fig. 17. *R* frequency characteristic of the recording amplifier in the Philips cassette player. *T* overall frequency characteristic, measured via recording and playback (not including microphone and loudspeaker).

any hum in equipment supplied from the mains. The frequency characteristic resulting from all the corrections applied in recording and playback is represented by curve *T* of fig. 17. The corresponding signal-to-noise ratio for present-day players and tapes is about 45 dB.

"Musicassettes"

All musicassettes are prerecorded with stereo programmes. To speed up production the music programmes on the master tape are not transferred to the cassette tapes at the nominal tape speed but at a considerably higher speed, 32 times higher in the latest production machines. This means that the master tape, which is modulated at a speed of 19.05 cm/s, is played at the rather astonishing speed of slightly more than 6 metres per second. The cassette tapes, four of which are modulated simultaneously with the signal from the master tape, are run at a speed of more than 1.5 m/s. All four tracks are prerecorded simultaneously, one pair from back to front.

During the copying process all frequencies are multiplied by a factor of 32; the amplifiers cover a frequency range of 200 Hz to 500 kHz and the playback and recording characteristics are correspondingly transformed. The high-frequency bias current has a frequency of 2.4 MHz. Ferrite heads are used to avoid eddy current losses and rapid wear; the gap length of the recording heads is 4 μ m.

Large numbers of programmes are successively played on to a single cassette tape 1500 metres long, the programmes being punctuated by signal tones which act as "cues" in the semi-automated assembly process for the cassettes. It would exceed the scope of this article to go into the details of this process [11]. During recording great care is taken to minimize flutter, which is less than 0.06% when properly weighted by the curve of fig. 14. The perpendicular alignment of the recording gap is also carried out very accurately, the angular errors being less than 2'. This is very important, because azimuth errors in playback equipment can seriously impair the quality of reproduction when musicassettes are played; everything possible is done to ensure that the recording process contributes as little as possible to azimuth errors that may ultimately exist.

Pocket Memo

The development of the Philips Pocket Memo (fig. 2) was prompted by the desire to market an extremely small dictation machine that could be carried in the pocket and used for making quick verbal notes. Small size was the principal requirement which the design had to meet; a playing time of 2×10 minutes (or 2×15 minutes with

[11] For further information see J. L. Ooms, Multiple speed tape duplicating, *J. Audio Engng. Soc.* 14, 343-355, 1966.

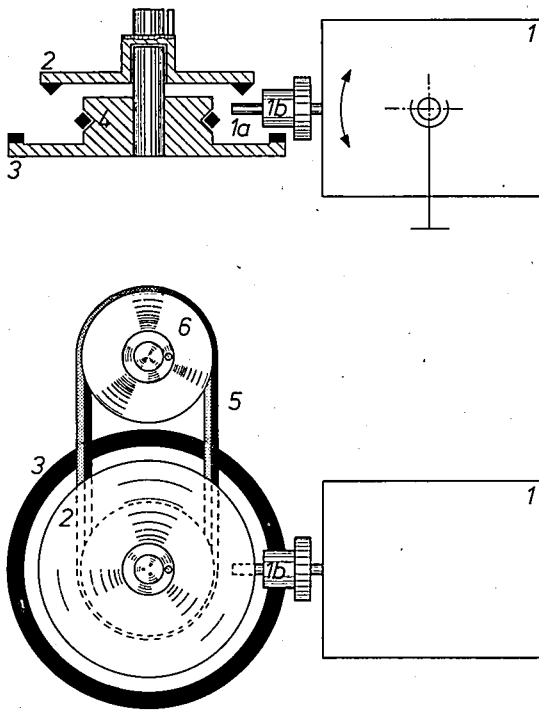

Fig. 18. Transport mechanism of Pocket Memo. 1 motor, 1a, b pinions on motor shaft. 2 turntable of take-up reel. 3 driving wheel for supply reel with 4 pulley wheel. 5 rubber belt. 6 turntable of supply reel.

9 μm tape) was desired, and also a rewind facility. A cassette was here the obvious means of making the audio tape manageable. We have already mentioned above that the Pocket Memo does not use a capstan for tape transport but uses instead the mechanically much simpler system of transporting the tape directly by means of the take-up reel. Apart from saving space and simplifying the transport mechanism, this has the advantage that less current is required. This is because there is no need of the slipping clutch used in capstan drive of the take-up reel, and this slipping clutch usually takes a fairly large amount of power (see fig. 15 which shows the distribution of the power taken by the transport mechanism of the cassette).

Transport mechanism

The simplicity of the transport mechanism in the Pocket Memo can clearly be seen in fig. 18. Attached to the shaft of the motor 1 is a double pinion 1a, b. In the "record/playback" position the motor shaft is tilted upwards and presses pinion 1a, which has a diameter of 1 mm, against a rubber rim on the turntable 2 of the take-up reel. In the "rewind" position the motor shaft is tilted downwards, and pinion 1b runs on the rubber rim of wheel 3. Mounted on the same spindle as wheel 3 is a pulley wheel 4 which drives the supply reel via belt 5 in the direction to wind the tape back on to the reel.

The rotating parts are given rotational frequencies that are as far removed as possible from the value of 4 rev/s (fig. 19), since the human ear is most sensitive to flutter at a frequency of 4 Hz (page 88). A frequency analysis of the flutter is shown in fig. 20, in which the motor frequency f_m and some of its harmonics can be seen.

The Pocket Memo is provided with the same electronic motor speed control as the cassette player. The circuit is shown in fig. 11. In the Pocket Memo a signal is derived from the control circuit to give an indication of the battery voltage. Superimposed on the collector d.c. voltage of Tr 2 is an a.c. voltage due to the commutation of the d.c. motor. By means of a battery-check switch this voltage can be applied to the playback amplifier. If the battery voltage falls too low, there is no longer any voltage across Tr 2, which then becomes effectively a short-circuit to earth, and consequently the a.c. voltage will no longer give an audible signal.

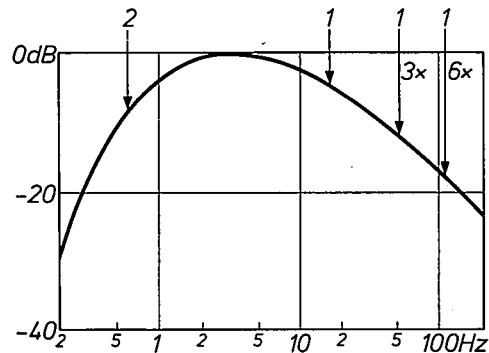

Fig. 19. The motor 1 and the take-up reel 2 (see fig. 18) are given rotational frequencies which are as far removed as possible from the frequency 4 Hz, which is the most annoying flutter frequency. An indication is given of where they lie in relation to the weighting curve of fig. 14. Unbalance of the rotor windings, magnetic "cling" at certain angular positions and commutator effects can lead to fluctuations with frequencies of 3 and 6 times the motor speed.

Tape modulation, frequency characteristic

The Pocket Memo incorporates a moving-coil microphone, which also acts as loudspeaker when the recording is played back. To ensure a good signal-to-noise ratio it is desirable that the tape should be modulated to a reasonable output level, irrespective of the distance from which the microphone is spoken into. In most tape recorders, and in the cassette players as well, the recording level is adjusted by hand; in the Pocket Memo, however, this would make it unacceptably complicated to use. The Pocket Memo is therefore given a fixed recording level, which is set fairly high; signal limitation is provided by the natural saturation of the tape. Steps have been taken to ensure that the recording amplifier remains well within the limits of its range of linear operation even when the tape is modulated into saturation, so that the tape is in fact the only limiting element. The manner in which the tape limits the signal gives less annoying non-linear distortion than overdriving an amplifier, and the intelligibility of speech is not so greatly affected.

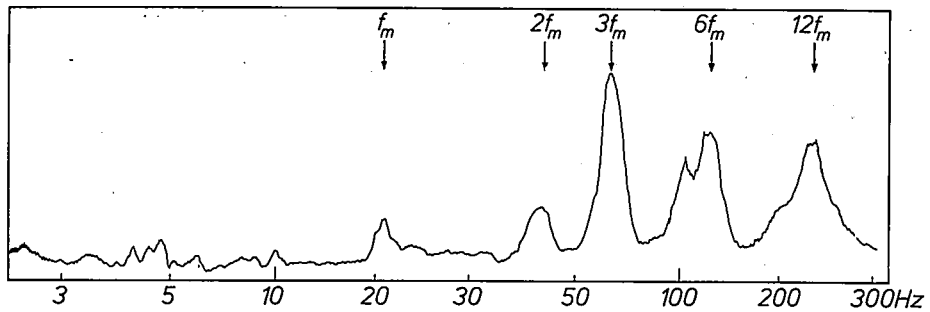

Fig. 20. Frequency analysis of the flutter in the transport mechanism of a Pocket Memo. In the frequency band from 2.5 Hz to 300 Hz shown here the flutter originates entirely from the motor. This turns at a speed of f_m revolutions per second; the component at the frequency $3f_m$ is due to magnetic unbalance of the rotor windings, the $6f_m$ frequency component is due to magnetic "cling" and commutator effects, and the $12f_m$ component is due to the commutator alone.

Intelligibility of speech is again the significant factor that should be borne in mind when examining *fig. 21*, which shows the frequency characteristic of the Pocket Memo, measured at the output terminals with an

ohmic load. The frequency characteristic does not therefore comprise the microphone/loudspeaker; it can be seen that it favours the frequencies which are of main importance for the intelligibility of speech.

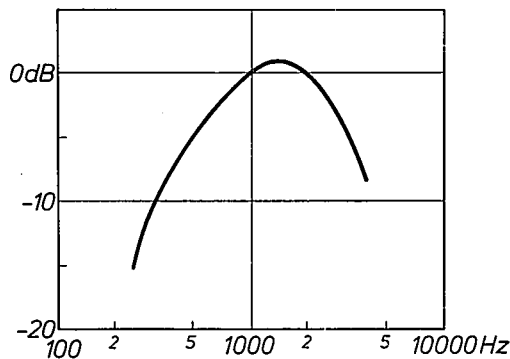

Fig. 21. Frequency characteristic of the Pocket Memo for recording and playback, excluding the frequency response of the microphone/loudspeaker. The characteristic favours the frequencies important for intelligibility of speech.

Summary. Because they are easy to manipulate and provide effective protection of the tape, audio tape cassettes are coming into ever-increasing use. Largely because of the continued improvement of tapes, it is now possible to use simple mass-produced cassette equipment to record frequencies up to 10 kHz at a tape speed of 4.76 cm/s, and to obtain a signal-to-noise ratio of 45 dB on a track width of 1.5 mm. This has led to the development of the Philips Compact Cassette with a playing time of 2×60 minutes (on a tape $9 \mu\text{m}$ thick); it is also marketed with a stereophonically prerecorded tape (Musicassette, maximum playing time 1×45 min). Cassette recorders and players are mostly portable and can work from batteries; an electronic control circuit keeps the motor speed constant as the battery voltage decreases.

The Philips miniature dictating machine, the Pocket Memo, is equipped with an even smaller cassette, specially developed for this machine, which gives a maximum playing time of 2×15 min. The tape is transported directly by the take-up reel; with this system the cassette and machine can be kept small and simple, and the current required is small.