

Service
Service
Service

Service Manual



Wow and Flutter: Max. value 0.16 %
Average value 0.12 %

Pleurage et scintillement: Valeur max. 0.16 %
Valeur moyen 0.12 %

Dimensions: 389x335x151 mm

1 LIFT AUTOMATIC LEVIER AUTOMATIQUE

Max. lift height by command disc 116
Hauteur max d'élévation par disque de commande 116

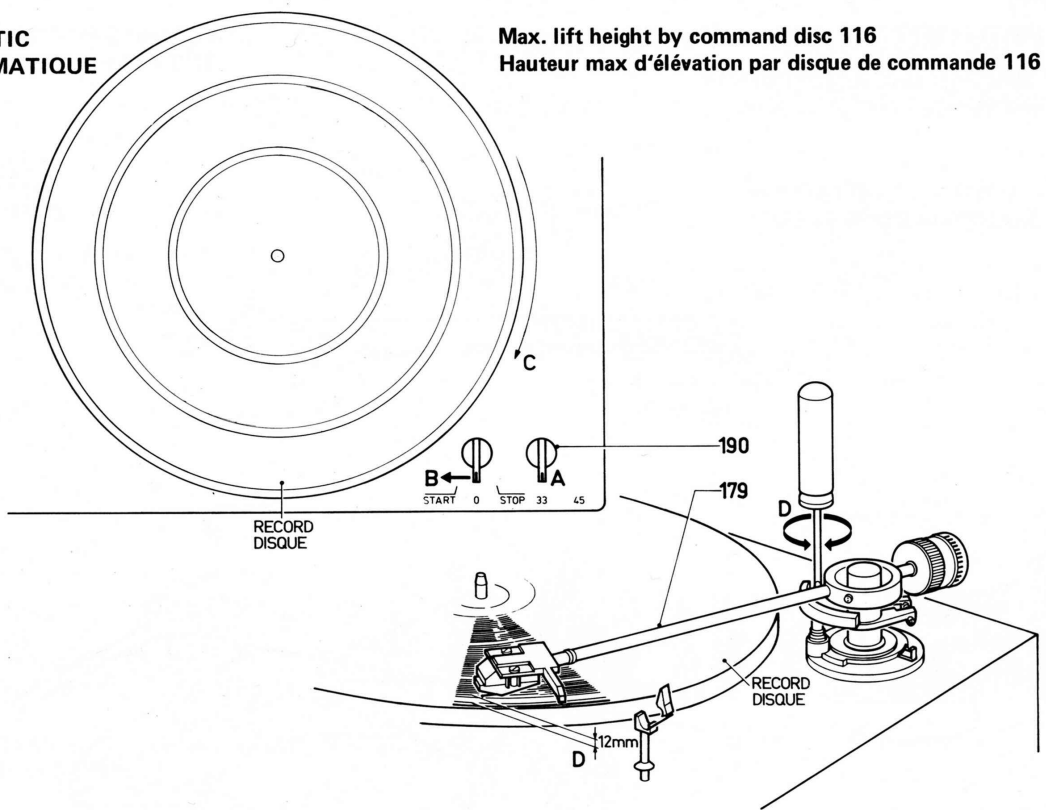
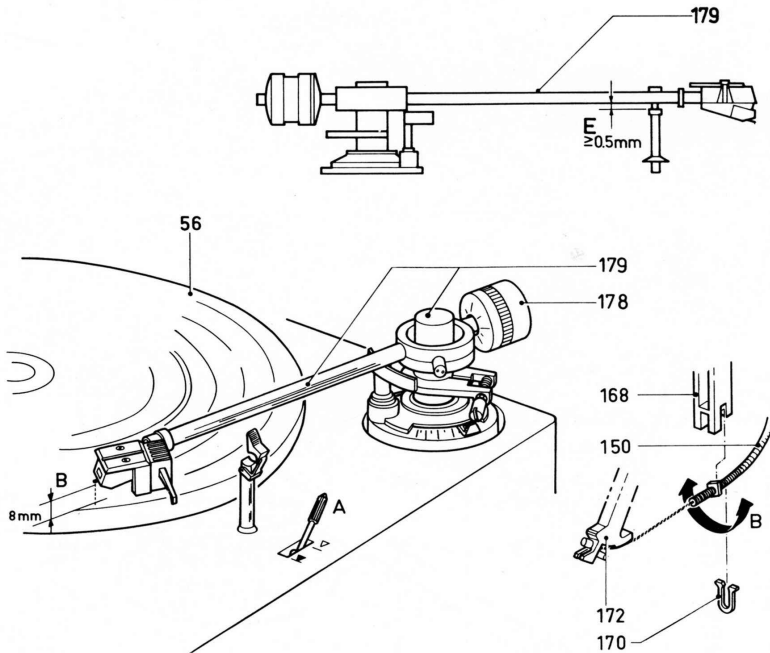

Fig. 3

2 LIFT MANUAL LEVIER MANUEL



17043C12

Fig. 4

16899B12

LUBRICATING INSTRUCTION (Fig. 9) INSTRUCTIONS DE LUBRIFICATION (Fig. 9)

- (A) All purpose oil 4822 390 10048
Items 62,63,70,
141
- (B) Shell Alvania II 4822 389 10001
Items 127,130
- (C) Silicone grease medium 300 4822 390 20031
Items 110,152,162,
163,508,515

- (D) Lubricant 10 4822 390 10003
Items 96,512
- (E) Silicone fluid 60.000 cst 4822 390 10045
Item 148



R310

SWITCH 147
COMMUTATEUR 147

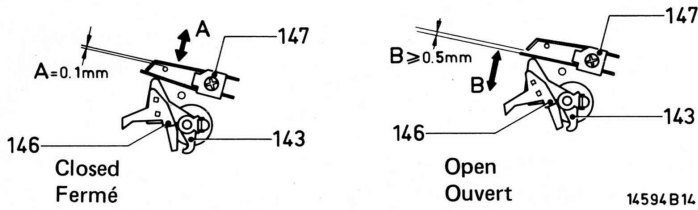

Fig. 5

MUTING SWITCH 98
INTERRUPTEUR DE COURT CIRCUIT 98

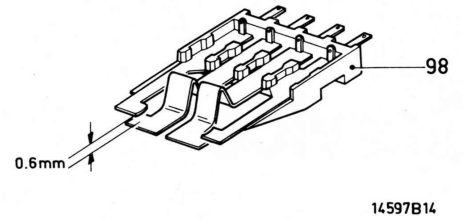

Fig. 6

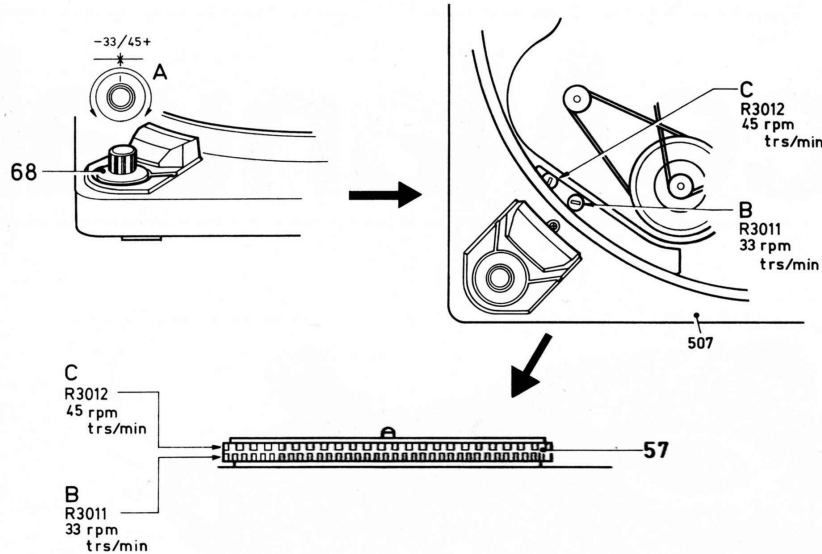

Fig. 7

REPAIR HINT
CONSEIL REPARATION

DEMOUNTING PIN 133
BROCHE DE DEMONTAGE 133

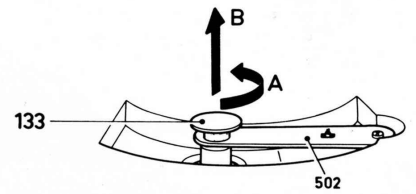
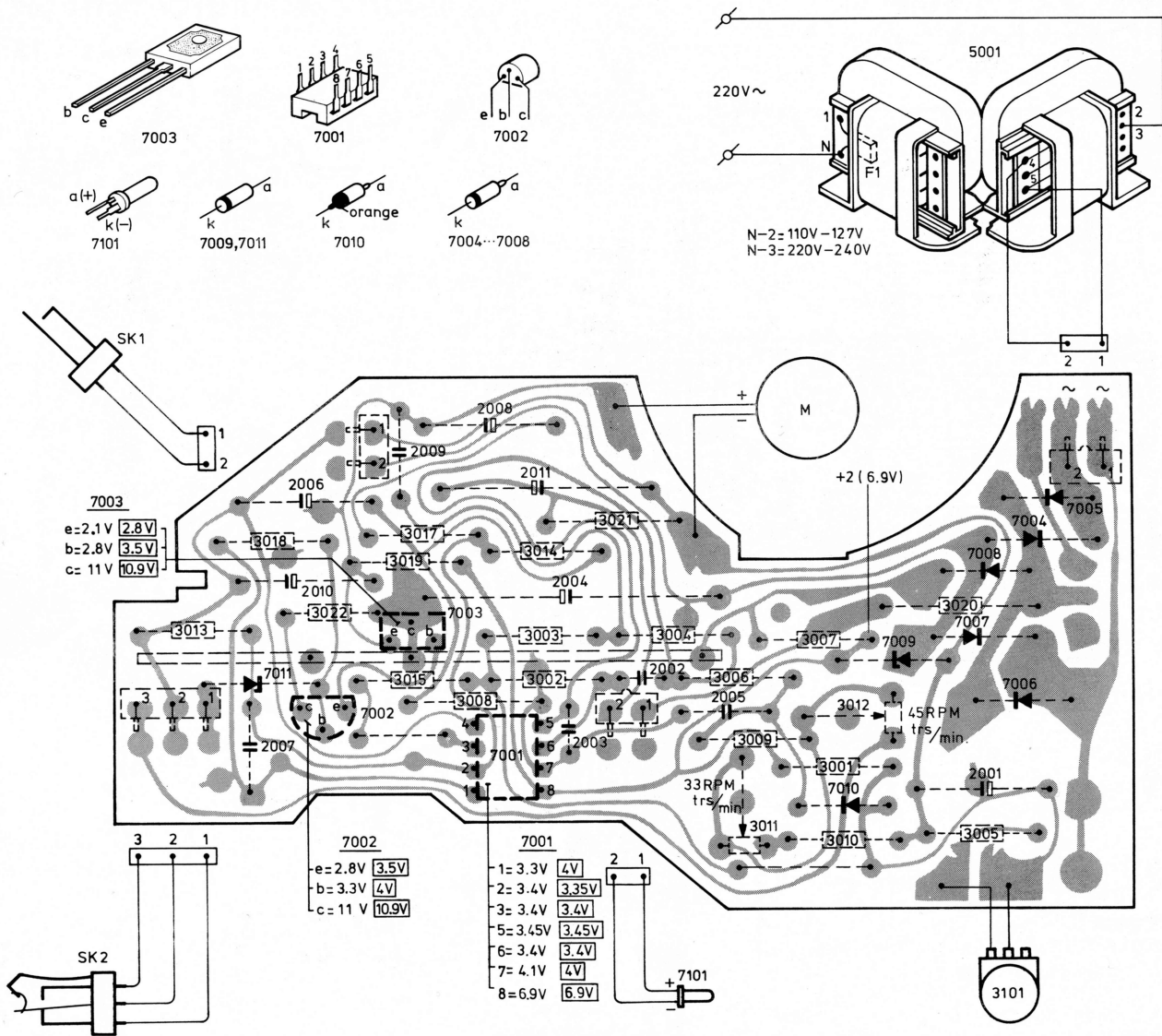

Fig. 8

LIST OF MECHANICAL PARTS (Fig. 9)
NOMENCLATURE DES PIECES MECANIQUES (Fig. 9)

51	4822 535 60043	83	4822 402 60649	128	4822 520 40011	166	4822 529 50096
52	4822 532 80647	87	4822 402 60646	130	4822 520 40124	167	4822 520 40011
56	4822 466 50128	90	4822 358 30217	132	4822 532 60638	168+166+172	4822 402 50148
57	4822 528 10362	91	4822 358 30216	133	4822 525 70523	169	4822 402 60639
58	4822 530 80194	92	4822 361 20149	136	4822 325 80066	170	4822 530 70237
59	4822 492 40812	93	4822 462 40361	137	4822 256 90263	171	4822 492 40766
60	4822 528 60112	96	4822 535 91101	138	4822 535 70526	172	4822 402 60641
61	4822 505 10579	97	4822 492 62127	140	4822 532 60673	173 (SK2)	4822 277 10398
62	4822 492 50221	98	4822 278 90334	141	4822 528 80704	174	4822 492 51283
63	4822 492 51219	101	4822 492 51218	142	4822 520 10393	175	4822 502 11377
64	4822 502 11396	102	4822 535 70524	143	4822 402 50152	176	4822 402 60652
66	4822 256 90264	103	4822 402 60654	146	4822 402 30103	177	4822 502 11401
67	4822 462 71125	106	4822 402 60653	147 (SK1)	4822 278 90007	178	4822 691 30074
68	4822 413 40775	107	4822 492 40763	148	4822 691 30073	179+174+181+	4822 251 70171
69	4822 532 60673	110	4822 402 60651	150	4822 535 70525	184+M2	4822 502 11378
70	4822 402 60636	111	4822 535 60042	151	4822 492 40764	180	4822 502 11378
71	4822 101 20533	112	4822 402 60644	152	4822 402 50149	181	4822 691 30079
72	4822 492 31446	113	4822 402 60645	153	4822 492 31441	182	4822 265 30145
73	4822 402 50153	116	4822 528 60111	154	4822 532 10767	183	4822 505 10578
76	4822 402 60642	118	4822 492 31443	156	4822 528 30174	184	4822 502 11402
77	4822 402 60643	121	4822 492 31439	157	4822 492 31444	186	4822 532 70156
78	4822 492 40759	122	4822 492 62125	158	4822 462 40355	187	4822 532 70155
80	4822 402 60647	123	4822 532 20674	161	4822 402 50151	188	4822 444 30246
81	4822 402 60648	126	4822 492 40765	162	4822 492 40761	190	4822 411 40022
82	4822 402 30102	127	4822 532 20673	163	4822 492 40762	191	4822 492 31445
						192	4822 535 91095



MISC	SK1.2	7011	7002	7003	7001	7101	F1.M.7010.7009.5001.7006...7008.7004.7005
C		2007 2010 2006	2009	2008.2011.2004.2003.2002 2007 2005			2001
R		3013 3018 3022	3019.3017	3003.3014 3021 3004 3006 3007.3012 3020			
R			3015.3008 3002	3009.3011 3001.3010 3005.3101			

16953D12

Fig. 12

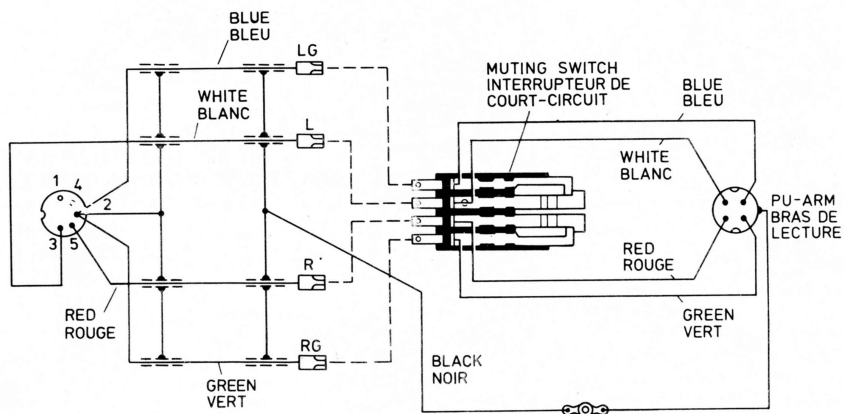

4822 321 20333 (DIN)
4822 321 20384 (Cinch)

Fig. 13

14304A3

MISC	7010	F1 5001	SK1 7004+7007 7001a	SK2 7101 7008	7009	7001b	7002 7011	7003 M	MISC
C	2001	2009	2002	2003 2005 2011	2006	2004 2008	2007	2010	C
R	3101 3005 3001	3003 3002 3004 3006		3008 3014 3015 3013 3017			3018	3022	3019
R	3010 3011 3009	3012		3020 3021	3007				

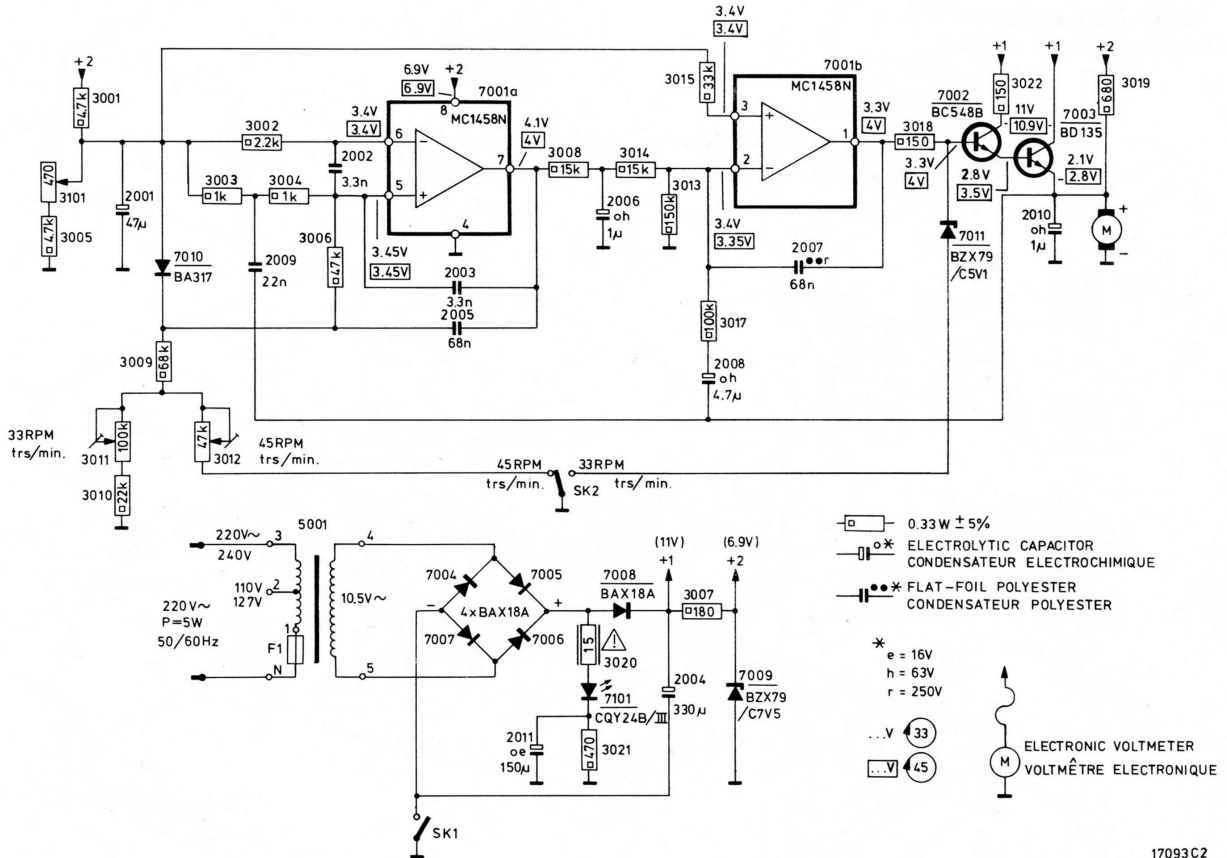

Fig. 11

**LIST OF ELECTRICAL PARTS
NOMENCLATURE DES PIÈCES ÉLECTRIQUES**

-IC-		-R-	
7001	MC1458N 5322 209 85512	3011	100 K/lin. 4822 100 10052
-TS-		3012	47 K/lin. 4822 100 10079
7002	BC548B 4822 130 40937	3020	15R, 0.2 W 5322 111 44153
7003	BD135 4822 130 40645	3101	470R/lin. 4822 101 20533
-D-		-C-	
7004-7008	BAX18A 4822 130 31025	2001	47 μF - 10 V 4822 124 20637
7009	BZX79-C7V5 4822 130 30861	2002,2003	3N3 - 100 V 4822 122 30099
7010	BA317 4822 130 30847	2004	330 μF - 25 V 4822 124 20705
7011	BZX79-C5V1 5322 130 34233	2005	68 N - 250 V 4822 121 41156
-LED-		2009	22 N - 250 V 4822 121 40407
7101	CQY24B/III 4822 130 31144	-Miscellaneous - divers -	
		5001	4822 146 30294
		F1	4822 252 20007
		M	4822 361 20149
		SK1	4822 277 10398
		SK2	4822 278 90007

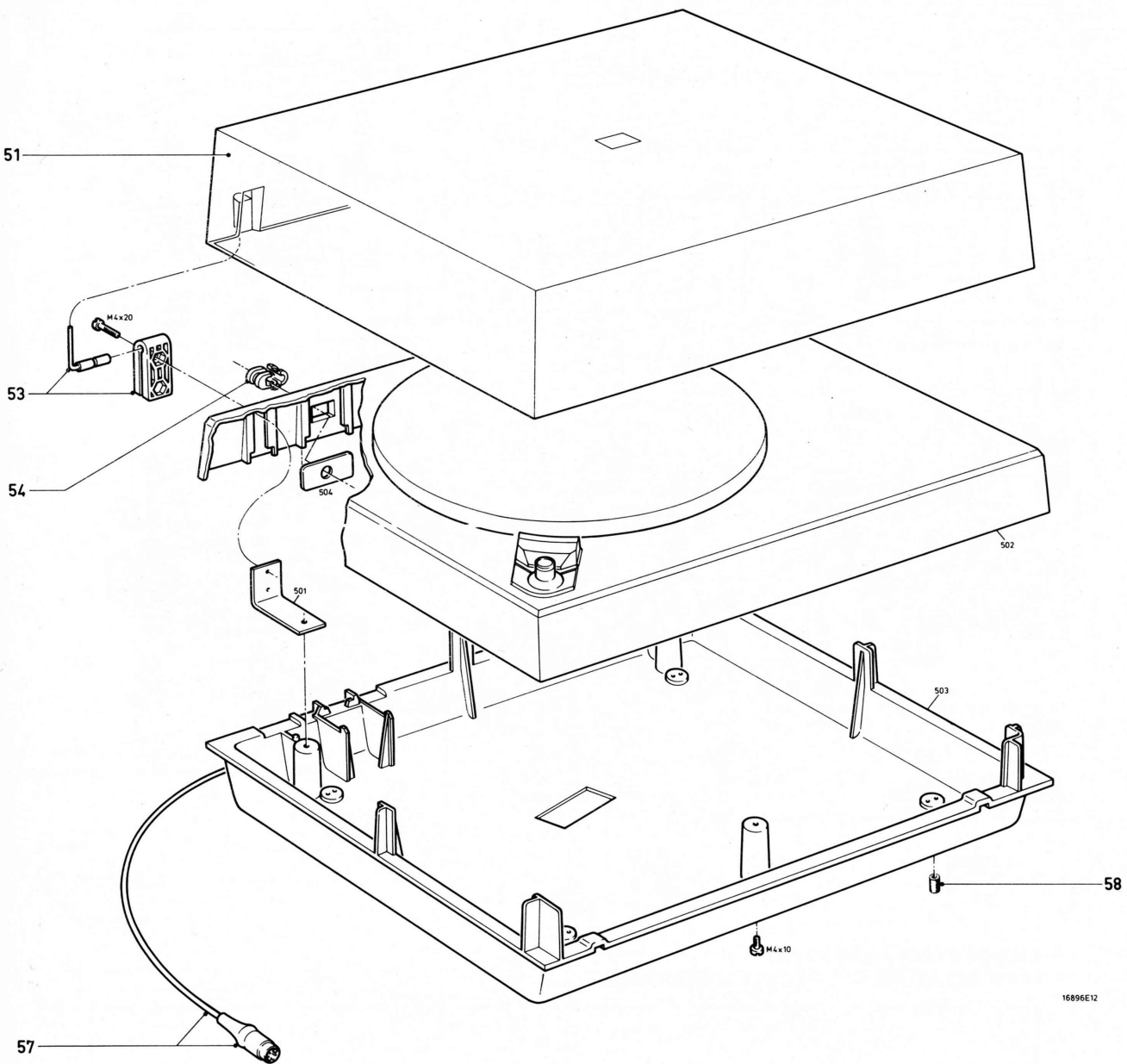

Fig. 10

LIST OF MECHANICAL PARTS (Fig. 10)
NOMENCLATURE DES PIÈCES MÉCANIQUES (Fig. 10)

51	4822 444 60351
53	4822 417 10631
54	4822 397 60048
57 (DIN)	4822 321 20333
57 (cinch)	4822 321 20384
58	4822 462 40353

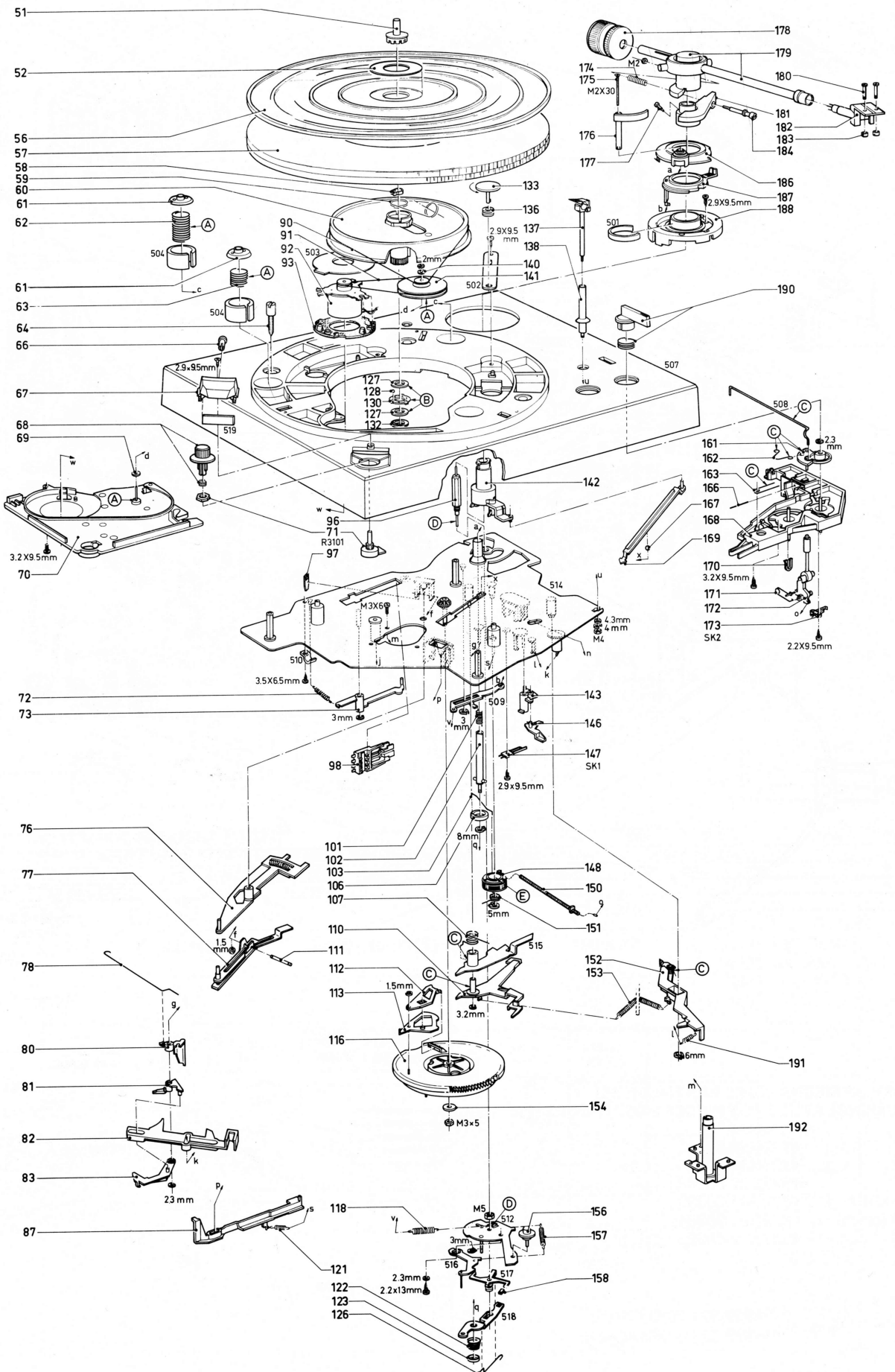

Fig. 9