

MODEL 640
Chassis
Parts

PHILCO RADIO & TELEV. CORP.

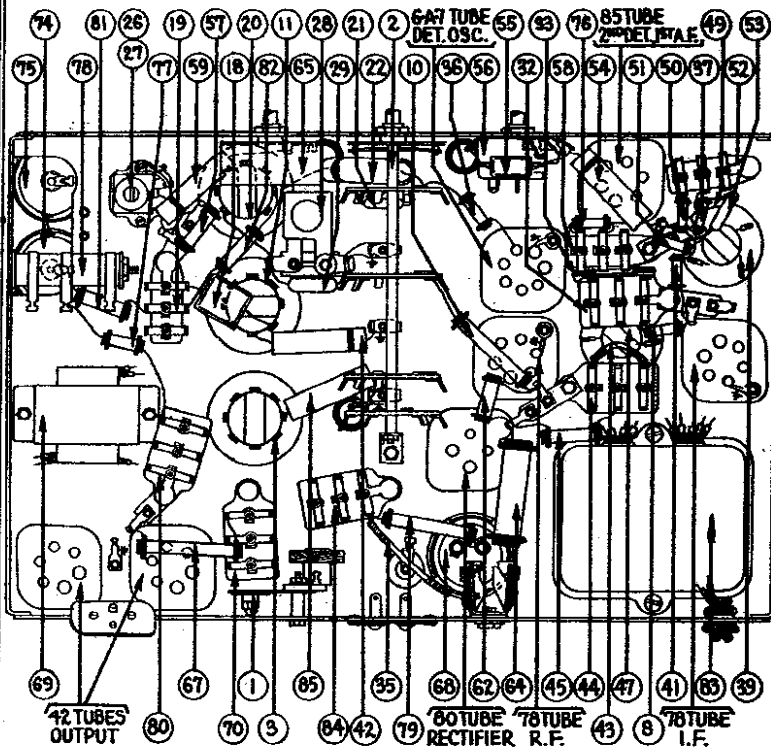

Fig. 3. Bottom View of Chassis

Replacement Parts
Model 640

*After Run 2, this is 30-1032 Mica, List .35.

Description	Part No.	List Price
Dial Scale.....	27-5103	.30.
Dial Hub and Set Screw Assembly.....	31-1550	.15
Dial Spring Clamp.....	28-2837	.10
Tube Shield.....	28-2726	.10
Tube Shield Base.....	28-2725	.03
Socket (4-Prong).....	27-6034	.10
Socket (6-Prong).....	27-6036	.11
Socket (7-Prong).....	27-6037	.11
Socket (Speaker Plug).....	27-6033	.08
Knob (Station Selector).....	27-4206	.12
Knob (Fine Tuning).....	27-4207	.10
Knob (Waveband).....	27-4219	.10
Knob (Volume Control or Tone Control).....	27-4208	.10
Bezel.....	28-2933	.35
Glass.....	27-7931	.60
Chassis Mtg. Screw.....	W-1495	1.50 per C
Chassis Mtg. Washer.....	27-4198	.01
Chassis Mtg. Rubber Bumper.....	27-4197
Condenser (.05 Mfd. Twin Bakelite Block).....	3615-DU	.40
Resistor (1000 ohms) (Brown-Black-Red).....	5837	.20
Compensating Condenser (2d I.F. Primary).....	Part of 47
2d I.F. Transformer.....	32-1712	2.00
Compensating Condenser (2d I.F. Secondary).....	Part of 47
Resistor (330000 ohms) (Orange-Orange-Yellow).....	33-1200	.20
Resistor (25000 ohms) (Red-Green-Orange).....	33-1013	.20
Resistor (50000 ohms) (Green-Brown-Orange).....	6098	.20
Condenser (.00025 Mfd. Bakelite Block).....	31-17-SG	.25
Condenser (.00011 Mfd. Mica).....	30-1031	.35
Condenser (.05 Mfd. Tubular).....	30-4020	.35
Condenser (.00011 Mfd. Mica).....	30-1031	.35
Volume Control and On-Off Switch.....	33-5113	1.45
Resistor (20000 ohms) (Red-Black-Orange).....	6650	.20
Condenser (.01 Mfd. Bakelite Block).....	3903-SU	.35
Condenser (.03 Mfd. Mica).....	30-4025	.30
Condenser (in Tone Control).....	Part of 46
Shadow Tuning Meter.....	45-2080	2.50
Resistor (4000 ohms) (Yellow-Black-Red).....	33-1040	.20
Pilot Lamp (Shadow Tuning Meter).....	Part of 41
Resistor (16000 ohms) (Brown-Blue-Orange).....	33-1201	.35
Tone Control.....	30-4333	.75
Condensers in Tone Control.....	Part of 46
Resistor (32000 ohms) (Orange-Red-Orange).....	3525	.20
Condenser (Electrolytic) (2 Mfd., 2 Mfd., 1 Mfd.).....	30-2114	2.25
Audio Transformer.....	32-7471	2.10
Condenser (.002 Mfd. Twin Bakelite Block).....	7296-DU	.30
Voice Coil & Cone Assembly { K-31.....	36-3159	.80
{ H-21.....	02625	1.20
Field Coil & Pot Assembly { K-31.....	36-3463	3.75
{ H-21.....	36-3461	3.75
Condenser (8 Mfd. Electrolytic).....	30-2025	1.35
Condenser (12 Mfd. Electrolytic).....	30-2117	1.50
Resistor (1 Meg.) (Brown-Black-Green).....	33-1171	.20
Resistor (.5 Meg.) (Yellow-White-Yellow).....	33-1169	.20
Resistor (B.C. Wirewound, 60 Ohms, 100 Ohms).....	33-3208	.20
Resistor (20000 ohms) (Red-Black-Orange).....	6649	.20
Condenser (.09 Mfd. Twin Bakelite Block).....	4989-DG	.40
Resistor (15000 ohms) (Brown-Green-Orange).....	6208	.20
Resistor (15000 ohms) (Brown-Green-Orange).....	6208	.20
Power Transformer (115 Volts 60 Cycles).....	32-7462	6.00
Condenser (.015 Mfd. Twin Bakelite Block).....	3793-DG	.40
Condenser (.05 Mfd. Tubular).....	30-4020	.35

Description	Part No.	List Price
Wave Trap.....	38-6850	\$1.10
Waveband Switch.....	42-1114	2.50
Antenna Transformer.....	32-1708	4.00
Compensating Condenser (Ant.) (Police).....	Part of 3
Compensating Condenser (Ant.) (Standard).....	Part of 3
Compensating Condenser (Ant.) (Longwave).....	Part of 3
Compensating Condenser (Ant.) (Shortwave).....	Part of 3
Resistor (.5 meg.) (Yellow-White-Yellow).....	6097	.20
Resistor (25000 ohms) (Red-Green-Yellow).....	3656	.20
R.F. Transformer.....	32-1709	3.75
Compensating Condenser (R.F. Longwave).....	Part of 11
Compensating Condenser (R.F. Broadcast).....	Part of 11
Compensating Condenser (R.F. Police).....	Part of 11
Compensating Condenser (R.F. Shortwave).....	Part of 11
Condenser.....	Part of 11
Condenser.....	Part of 11
Condenser (.0018 Mfd. Mica).....	6018	.40
Condenser (.05 Mfd. Bakelite Block).....	3615-SG	.35
Oscillator Transformer.....	32-1710	3.00
Condenser (.000015 Mfd. Mica).....	30-1030	.35
Condenser (.01 Mfd. Tubular).....	*30-4145	.25
Compensating Condenser (Osc. S.W.).....	Part of 22
Compensating Condenser (Osc. Longwave).....	Part of 22
Compensating Condenser (Osc. B.C. & Police).....	Part of 22
Compensating Condenser (Osc. L.W. Series) Part of 31-604450
Compensating Condenser (Osc. B.C. Series) Part of 31-604450
Compensating Condenser (Osc. S.W. Series).....	04000-R	.45
Condenser (.0022 Mfd. Mica).....	30-1057	.40
Tuning Condenser Assembly.....	31-1555	4.50
Condenser (.09 Mfd. Twin Bakelite).....	4989-DG	.40
Resistor (300 ohms) (Orange-Black-Black).....	33-3010	.20
Condenser (.05 Mfd. Tubular) (On top of chassis).....	30-4327	.20
Resistor (300 ohms Flexible) (Orange-Black-Black).....	33-3010	.20
Resistor (50000 ohms) (Green-Brown-Orange).....	6098	.20
Resistor (2 Megs.) (Red-Black-Green).....	33-1025	.20
Compensating Condenset (1st I.F. Primary).....	Part of 30
1st I.F. Transformer.....	32-1711	\$2.00
Compensating Condenser (1st I.F. Secondary).....	Part of 30
Resistor (2 Megs.) (Red-Black-Green).....	33-1025	.20
Condenser (.05 Mfd. Tubular).....	30-4020	.35
Resistor (300 ohms Flexible) (Orange-Black-Black).....	33-3010	.20

PHILCO RADIO & TELEV. CORP.

MODEL 640
Schematic

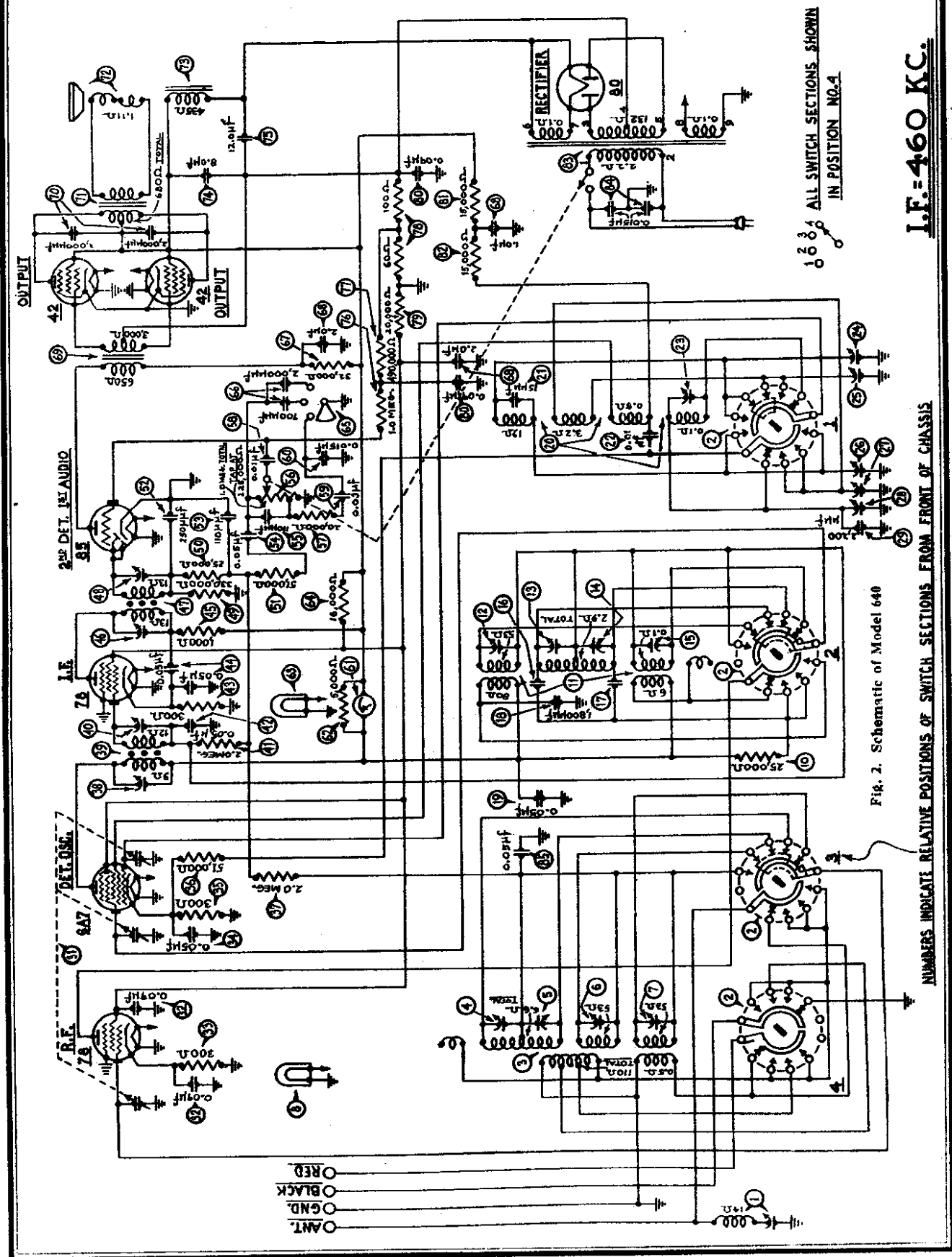

Fig. 2. Schematic of Model 640

NUMBERS INDICATE RELATIVE POSITIONS OF SWITCH SECTIONS FROM FRONT OF CHASSIS

PHILCO RADIO & TELEV. CORP.
Model 640

MODEL 640
Socket, Voltage
Trimmers, Alignment

Type Circuit: Superheterodyne, with preselector R.F. amplifier, and push-pull output (7 watts); built in connections for Philco All-wave aerial; aerial selector built into and operated by wave-band switch.

Power Supply: Alternating Current. Voltage and frequency as specified on chassis nameplate.

Tubes Used: 1 type 78, R.F.; 1 type 6A7, Detector-Oscillator; 1 type 78, I.F.; 1 type 85, 2d Detector and 1st A.F.; 2 type 42 Push-Pull Output; 1 type 80 Rectifier.

Wave Bands: Four: (1) Long-wave (U. S. Weather Forecasts); (2) Standard (with some Police); (3) Police; (4) Short-wave.

Coverage of Each Band: Band 1, 145 to 390 K.C.; Band 2, 540-1720 K.C.; Band 3, 2.2 to 2.6 M.C.; Band 4, 5800-18000 K.C. (5.8 to 18.0 megacycles).

Tuning Drive: Dual planetary, ball bearing. 80 to 1 ratio for slow-speed tuning, 10 to 1 on main shaft.

Tone Control: 4-position, with bass compensation effective in first position (counter-clockwise).

Intermediate Frequency: 460 K.C.

Power Consumption: 85 watts.

Speaker: 640B (Code 121); K-31, 640X (Code 122); H-21.

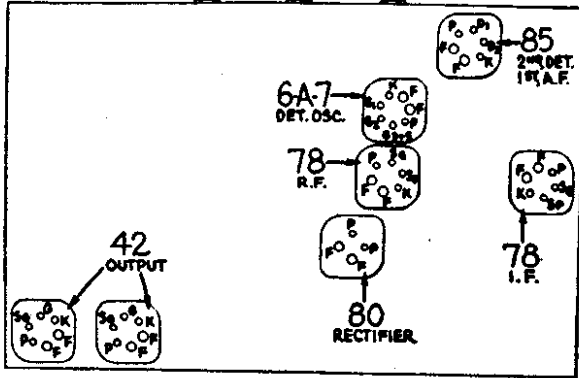

Fig. 1. Tube Sockets as viewed from bottom.
Power Transformer Data

Terminals	A.C. Volts	Current	Circuit	Color
1-2	120		Primary	White
3-5	710	118 M.A.	Secondary	Yellow
6-7	5.0	2.0 A.	Fil. Rect.	Blue
8-9	6.3	3.5 A.	Filaments	Black
4			Center Tap of 3-5	Yellow, Green Tracer

**Tube Socket Voltages (Line Voltage 115)
Measured to Ground**

Tube	78 R.F.	6A7 Det. Osc.	78 I.F.	85 2d Det.	42 Output
Point P	71	240	242	102	240
SG	91	91	91		250
K	2.1	2.2	2.3		

6A7: G₁ & G₂ = 102V. 80 Fil.—Gnd.: 300V.

Above voltages were obtained by using a PHILCO type 025 Circuit Tester (or 048A All-purpose Tester), using test prods applied to underside of chassis. Volume control at minimum; dial at 55; waveband switch at standard broadcast. Use Fig. 1 for test points. Type K-31 speaker employed.

Adjustment of compensating condensers in Model 640 requires an accurate signal generator covering long-wave, standard wave, police, and short-wave frequencies. The PHILCO Model 088 All-Wave Signal Generator, having a continuous range of from 100 to 20000 K.C., is ideal for this purpose.

An output meter is also needed. PHILCO Model 025 Circuit Tester includes a high grade output meter.

Philco No. 3164 fibre wrench and No. 27-7059 fibre handled screwdriver complete the equipment needed for making these adjustments. The locations of the various compensating condensers is shown in Fig. 2. Connect the output meter to the plate contacts of the 42 output tubes (using the adapters provided with the "025") and set it at the 0-30 volt range.

I.F.—Set the Signal Generator at 460 K.C., and attach its antenna lead to the grid cap of the 6A7 tube on the Model 640 (having removed the grid clip from the tube). Connect the ground terminal of the Signal Generator to the ground terminal of the set. Turn on the set, turn the waveband switch to second position (standard) and set dial at 55. Now with the fibre screwdriver, adjust condensers (26) and (27) (2d I.F.) and then (28) and (29) (1st I.F.) until maximum reading is obtained in the output meter. Turn down the "attenuator" on the signal generator if the output meter needle goes off the scale.

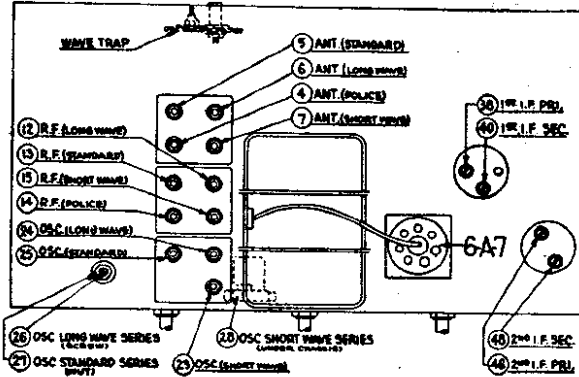

Fig. 2. Locations of Compensating Condensers

WAVE TRAP—Connect the Signal Generator antenna and ground leads to the antenna and ground posts of the set. Replace the grid clip on the 6A7 tube cap. With the signal generator operating at 460 K.C. and the set controls adjusted as for I.F., adjust wavetraps (1) until the minimum reading is obtained in the out-put meter.

SHORTWAVE—Turn waveband switch to position 4 (extreme right). Set signal generator at 18 megacycles and dial of set at 18.0 (top scale). Now adjust the oscillator, R.F., and Antenna compensators in turn, for maximum reading. These are (2), (3) and (7) respectively.

Turn the dial to 6.0 M.C., set the signal generator at 6.0 M.C., and adjust condenser (26) for maximum reading. This compensator is located underneath the chassis and reached from underneath. (See Fig. 3).

STANDARD WAVE—Turn waveband switch to position 2 (standard broadcast), set signal generator at 1500 and dial of set at 150. Now adjust the oscillator, R.F., and antenna "Standard" condensers. These are (3), (3) and (3) respectively.

Now turn the dial to 60, set signal generator at 600 and adjust condenser (27) (oscillator standard-series) (nut) for maximum reading.

POLICE BAND—Turn waveband switch to position 3 from left (police band); set dial at 2.4 and signal generator at 2400 K.C. Adjust condensers (28) and (29) for maximum reading. (Antenna and R.F. Police.)

LONG WAVE (Weather) BAND—Turn waveband switch to position 1 (left) (Longwave). Set dial at 35 and signal generator at 350 K.C. Adjust condensers (26), (29) and (3) (oscillator, R.F., and Antenna Longwave) for maximum reading.

Turn dial to 17, signal generator to 170 and adjust condenser (28) (longwave series) (screw) for maximum reading.