



MSGT D R BOYD 276 - 34 - 7141  
TOKI Y BOYD 501 - 74 - 3653  
81ST TFW BOX 2794 PH 2129  
APO NY 09755



**PHILIPS**

GA 209

**hi**  
HIGH FIDELITY **fi** INTERNATIONAL

# English

## 1. Description

This electronically controlled, fully automatic, two-speed record player combines the following features:

- exceeds the standards laid down by DIN 45500
- automatic start and selection of turntable speed
- automatic sensing of record diameter
- automatic return of pick-up at end of record
- option of manual or automatic operation
- built in protection against incorrect use
- direct reading stylus force indicator with adjustment between 0.75 and 3 grams
- adjustable side thrust compensation
- universal headshell to carry Super «M» cartridges, or most other cartridge having standard 1/2" (12.7 mm) fixing centres
- photo-electric auto-stop, noiseless in operation and exerting no force on the pick-up arm
- electronic servo control of hydraulically-damped pick-up arm lift by means of touch controls
- fully-floating turntable and pick-up arm suspension
- very low wow flutter and rumble
- separate motors for turntable drive, pick-up arm lift and automatic movement of pick-up arm
- low speed DC motor and belt-driven turntable
- 72 pole tacho-generator ensures constant turntable speed
- separate fine speed adjustment for 33 1/3 and 45 r.p.m.

## 2. Functions (fig. 1)

- ① mains ON/OFF switch
- ② stroboscopic ring (33 1/3 r.p.m.)
- ③ stroboscopic ring (45 r.p.m.)
- ④ retractable adaptor for records with large centre hole
- ⑤ | ⑥ record diameter sensor for 10" (25 cm) and 12" (30 cm) 33 1/3 r.p.m. records
- ⑦ sensor for auto-start device during automatic operation
- ⑧ pick-up headshell
- ⑨ pick-up arm lock
- ⑩ stylus force indicator
- ⑪ adjustable counterweight
- ⑫ + ⑬ indicator lamps for automatic and manual playing
- ⑭ speed indicator lamps (33 1/3 and 45 r.p.m.)
- ⑮ sliding cover of control panel, acting also as manual/automatic change-over switch
- ⑯ side thrust compensation control
- ⑰ fine speed control (33 1/3 r.p.m.)
- ⑱ fine speed control (45 r.p.m.)
- ⑲ start control (33 1/3 r.p.m.)
- ⑳ start control (45 r.p.m.)
- ㉑ stop control
- ㉒ touch control for lowering pick-up arm
- ㉓ touch control for raising pick-up arm
- ㉔ adjustment screw for pick-up set down position
- ㉕ output to amplifier
- ㉖ mains lead
- ㉗ adjustable friction hinges.

## 3. Installation (fig. 2)

### Mains Voltage Adjustment

Before connecting the unit to the mains, check that the voltage which appears in the aperture of the voltage adaptor ①, corresponds to the local mains voltage. If this is not the case, turn the adaptor with a coin until the correct indication appears. Equipment for Canada and U.S.A. have no voltage adaptor and are set to 117 V.

**Note:** Never turn the voltage adaptor with the unit connected to the mains.

### Transport locking

Remove the two wing-nuts and washers ②. The sub-chassis will then be freely suspended.

Always ensure that the wing-nuts and 2 washers are re-positioned when transporting the unit.

### Assembly

The turntable, counterweight and hardware necessary for mounting an alternative pick-up cartridge are packed separately, to prevent damage during transit.

Place the turntable over the turntable spindle ③ so that the sensor ④ passes through the aperture ⑤ in the turntable (fig. 3). Slide the counterweight ⑥ on to the end of the pick-up arm (fig. 4) and press gently until it engages with the spindle of knob ⑦. Turn the knob to slide the counterweight along the arm.

### Connections

Connect the mains cable to the socket ⑧ and insert the mains plug into the wall outlet.

**Note (U.K. Only):** The instrument may be connected to the mains via a suitable plug. The wires in the mains lead are coloured as follows:

Brown - Live

Blue - Neutral

If these colours do not correspond to the markings on the plug, proceed as follows:

Connect the blue lead to the neutral (N) or black pin; connect the brown lead to the live (L) or red pin. If a fused plug is used a 3 amp fuse should be fitted.

Connect the AF plug ⑨ to the magneto/dynamic pick-up socket of the amplifier. The pick-up cartridge fitted as standard with this record player supplies a signal that is ample to drive most Hi-Fi amplifiers. If there is no provision for magneto/dynamic cartridges an additional pre-amplifier will be required so that the unit may feed directly into the crystal or ceramic input.

### Adjustment of stylus force (fig. 1)

Open the sliding lid ⑮, and turn the side thrust compensation control to position «O». Unlock the pick-up arm by turning knob ⑨ to the right, and check that the pick-up arm lift is in the lower position. This is indicated by illumination of the touch control marked ▽. Operate the touch control if necessary.

By turning knob ⑪ the required stylus force may be obtained, its value being shown on the indicator ⑩.

The optimum stylus force for a particular cartridge will usually be quoted in its instructions. For Super M cartridges the recommended stylus forces are as follows:

GP 412 ..... 1.2 gf

GP 401 ..... 2 gf

GP 400 ..... 2 gf

It is important to have the correct stylus force. Too high a value leads to unnecessary record wear. Too low a value may result in incorrect tracking of the stylus in the record groove, or in groove jumping and subsequent damage.

### Side thrust compensation (fig. 1)

Due to the geometry of the pick-up arm and the friction of the stylus in the groove, a force is created which tends to move the pick-up arm towards the centre of the record, thus causing imperfect tracking. In order to avoid this effect this record player is provided with side thrust compensation that may be adjusted by means of knob ⑯.

The amount of side thrust compensation required depends upon the value of the stylus force, as read on the stylus force indicator ⑩.

For correct adjustment, set knob ⑯ to a position corresponding to the value of the stylus force. The scale marked «O» is for cartridges having a spherical (conical) stylus tip, the scale marked «○» is for cartridges with an elliptical (bi-radial) stylus tip. The super M pick-up cartridges, types GP 412 and GP 401 have an elliptical stylus tip, and the GP 400 has a conical stylus tip.

### Fine speed adjustment (fig. 1)

Fine speed control is an important feature, as it enables music to be reproduced at exactly the same pitch as when recorded.

Alternatively, the pitch may be adjusted to suit that of a musical instrument e.g. a piano, when playing along with a record.

Adjustment is possible by means of the separate fine speed controls ⑰ and ⑱ for 33 1/3 rpm and 45 rpm respectively.

To make the turntable to revolve at exactly 33 1/3 r.p.m. or 45 r.p.m. the procedure is as follows:

1. Press the mains switch ① and select the desired speed with pushbuttons ⑲ or ⑳, for 33 1/3 r.p.m. or 45 r.p.m. respectively (the appropriate indicator lamp will light up).
2. Turn the appropriate fine speed control so that the stroboscopic ring corresponding to that speed, (see «FUNCTIONS») viewed by the light of a lamp operating from the mains supply appears to be stationary. Turn the fine speed control to the left, if the stroboscopic ring seems to turn to the clockwise, and vice-versa.

**Note:** For countries with a mains frequency of 60 Hz, the record player is supplied with stroboscopic rings for 60 Hz.

#### 4. Operation

##### *General (fig. 1)*

The record player is switched on by pressing the mains switch ①. Depressing a second time switches the unit off. The touch controls ㉒ and ㉓ for lowering and raising the pick-up arm, may be used independently of the other operating controls.

For playing 45 r.p.m. records with a large centre hole the retractable adaptor ④ can be raised by gently pressing and simultaneously turning to the right. In order to return it, turn it to the left and press it downwards at the same time (fig. 5).

##### *Operation as an Automatic record player*

(For all standard, 45 r.p.m. records of 7" (17 cm) diameter, and 33 1/3 r.p.m. records of 10" (25 cm) and 12" (30 cm) diameter).

1. Press mains switch ①.
2. Ensure that cover ⑮ is closed; indicator lamp «Automatic» will light up.
3. Carefully push up the stylus-guard (fig. 6) or, if present, remove the loose sleeve protecting the stylus.
4. Unlock the pick-up arm by turning the knob ⑨ to the right.
5. Place a record on the turntable. The turntable will automatically start to revolve at the correct speed, the pick-up arm will move to the correct set down position. At the end of the record, the pick-up arm will automatically return to its rest, the turntable will stop.

##### *Repeated playing of an entire record*

After playing a record, it is possible to repeat it by opening cover ⑮, and closing it again.

##### *Repetition of part of a record*

Repetition of part of a record may be accomplished in the following way:

1. Actuate the touch control marked ▽.
2. Move the pick-up arm carefully to a position above the desired track.
3. Actuate the touch control marked ▽.

##### *Interruption of play*

This may be carried out in one of the following ways:

1. Open cover ⑮, and press the stop button ㉒. The arm will return to its rest position.
2. Actuate the touch control marked ▽. This facility is useful for short interruptions (e.g. when answering a telephone call). The record continues to rotate and the pick-up arm remains above the record. Actuating the touch control marked ▽ resumes playing at exactly the same point where it was interrupted.

##### *Switching off the record player*

Press the mains switch ①.

**Note:** If the mains switch is pressed immediately after the stop button, the record player will continue to complete its automatic cycle, and only then will switch itself off. (The indicator lamps will, however, be extinguished).

##### *Operation as a manual record player*

1. press the mains switch ①
2. open the cover ⑮: the indicator lamp «Manual» will light up
3. carefully pick up the stylus-guard (fig. 6) or, if present, remove the loose sleeve protecting the stylus
4. unlock the pick-up arm by turning the knob ⑨ to the right
5. place a record on the turntable
6. select the correct speed by pressing the push-button for 33 1/3 or 45 r.p.m. (the corresponding indicator lamp will light and the turntable start to revolve)
7. actuate the touch control marked ▽
8. position the pick-up arm above the desired part of the record
9. actuate the touch control marked ▽; the built-in damping mechanism will allow the stylus to descend gently on to the record
10. after the record has been played the motor will automatically switch off and the arm return to its rest.

**Note:** During «Manual Play» do not close cover ⑮ otherwise the record will be repeated from the beginning.

##### *Interruption of play*

Playing may be interrupted at any time by actuating the touch control marked ▽. If the stop button ㉒ is pressed, the motor will stop and the arm automatically return to its rest.

##### *Switching off the record player*

Press the mains switch ①.

#### 5. Maintenance

The diamond stylus is subject to very little wear, but is recommended to have it checked regularly, e.g. once a year, by your dealer.

Cleaning of the stylus can be performed by means of a small, soft haired brush.

The life of your records will be extended, if they are always kept clean using, for example, the Philips discleaner.

Putting on, removal, or cleaning of a record should only be done while the turntable is at rest.

The mechanism of this record player does not require any maintenance, since its bearings are self-lubricating.

#### 6. Adjustments

##### *Re-adjustment of hinges of dust-cover*

This record player is equipped with friction hinges which ensure that the cover will remain in any desired position.

Re-adjustment of the hinges may be necessary if the friction is too low, or too high.

This may be carried out by tightening, or loosening the screws ㉔ on the hinges (fig. 7).

**Note:** Never apply oil to the hinges.

##### *Adjustment of the pick-up arm (fig. 8)*

During automatic playing, the stylus should set down in the lead-in groove of the record. If adjustment is necessary, turn the set screw ㉕ using a screwdriver, to the right, in order to bring the pick-up arm nearer the centre, or to the left, to move the pick-up arm away from the centre.

#### 7. Pick-up cartridge

This record player is equipped with a Philips Hi-Fi Super M pick-up cartridge.

For inspection or replacement purposes, the cartridge can be removed quite simply by carefully pulling the sliding carrier, complete with cartridge, from the headshell (fig. 9). In order to fit an alternative Super M cartridge, gently pull the exiting cartridge from the carrier (fig. 10), and slide the new cartridge into position (fig. 11). The assembly may then be slid back into the headshell (fig. 9). Electrical contact is made automatically.

## English

### NOTE FOR INSTALLATION AND FIRST TIME OPERATION OF GA209

Vibration during transportation may cause the mechanism controlling the automatic operation of the pick-up arm to move from its «zero» position. In this case the indicator lamps will light on plugging in the mains cable, even before actuating the mains switch. Before proceeding to adjust stylus force and side thrust compensation, open the sliding cover of the control panel and depress either the 33 or 45 start control button (19) or (20) and, shortly after, depress the stop control button (21). The indicator lamps will then extinguish.

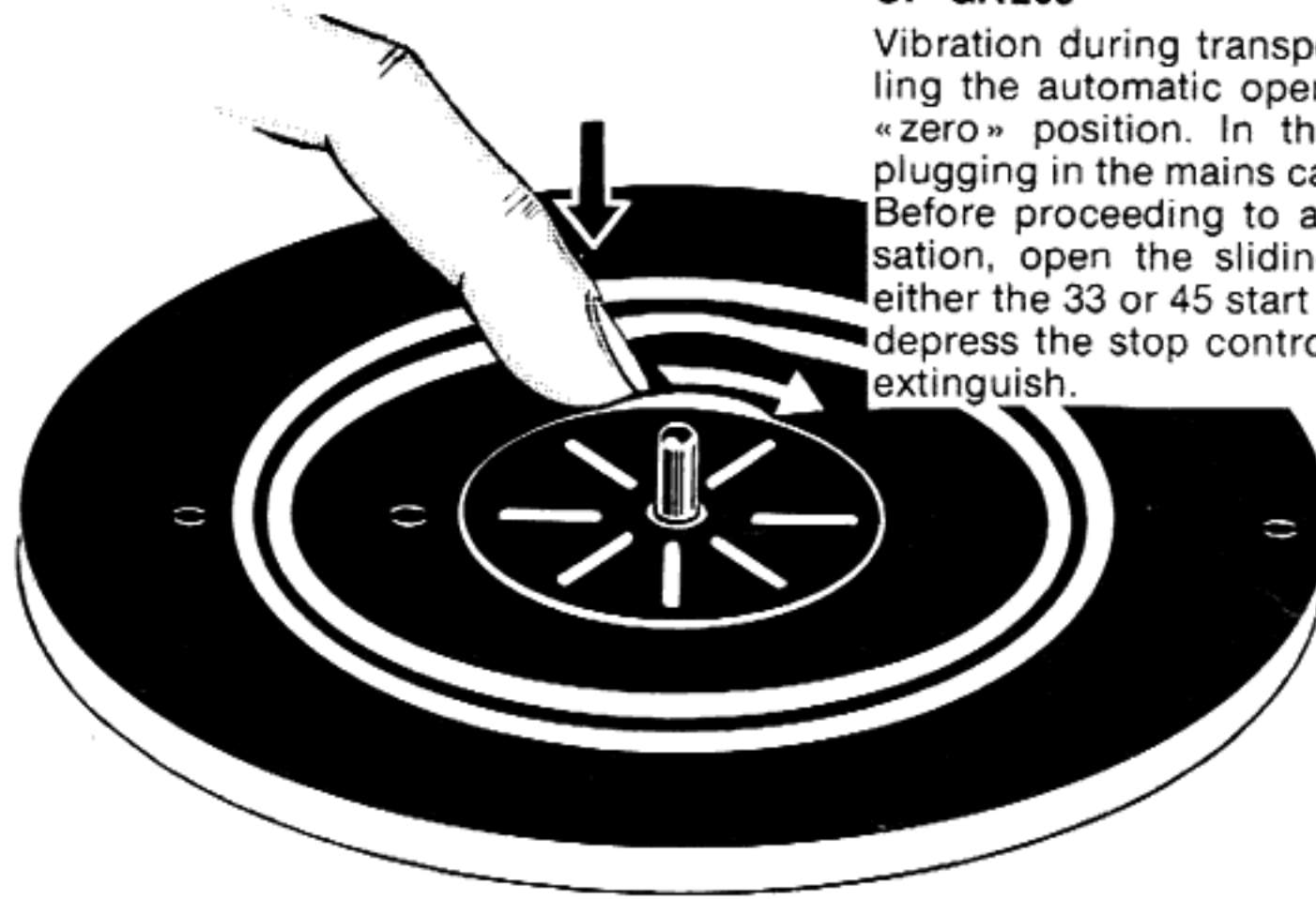

## English

### NOTE FOR INSTALLATION AND FIRST TIME OPERATION OF GA209

After placing the turntable over the turntable spindle, check that the mat is pressed well down around the retractable adaptor (see fig. 1).

## Français

### REMARQUE POUR LA PREMIERE MISE EN SERVICE DU GA209

Après avoir remonté le plateau sur son axe, s'assurer que le tapis en caoutchouc est bien positionné autour de l'adaptateur escamotable (fig. 1).

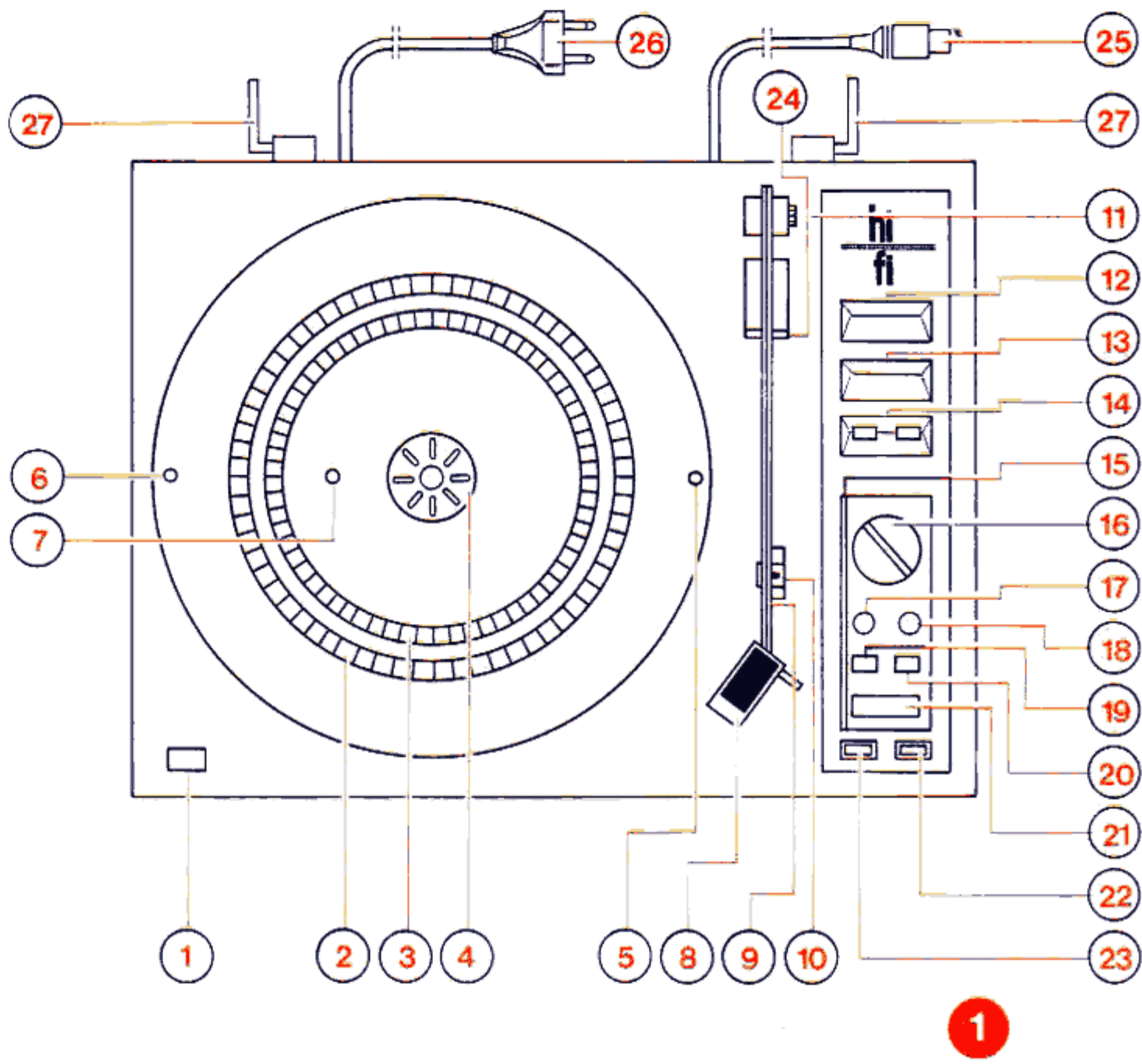

**1**

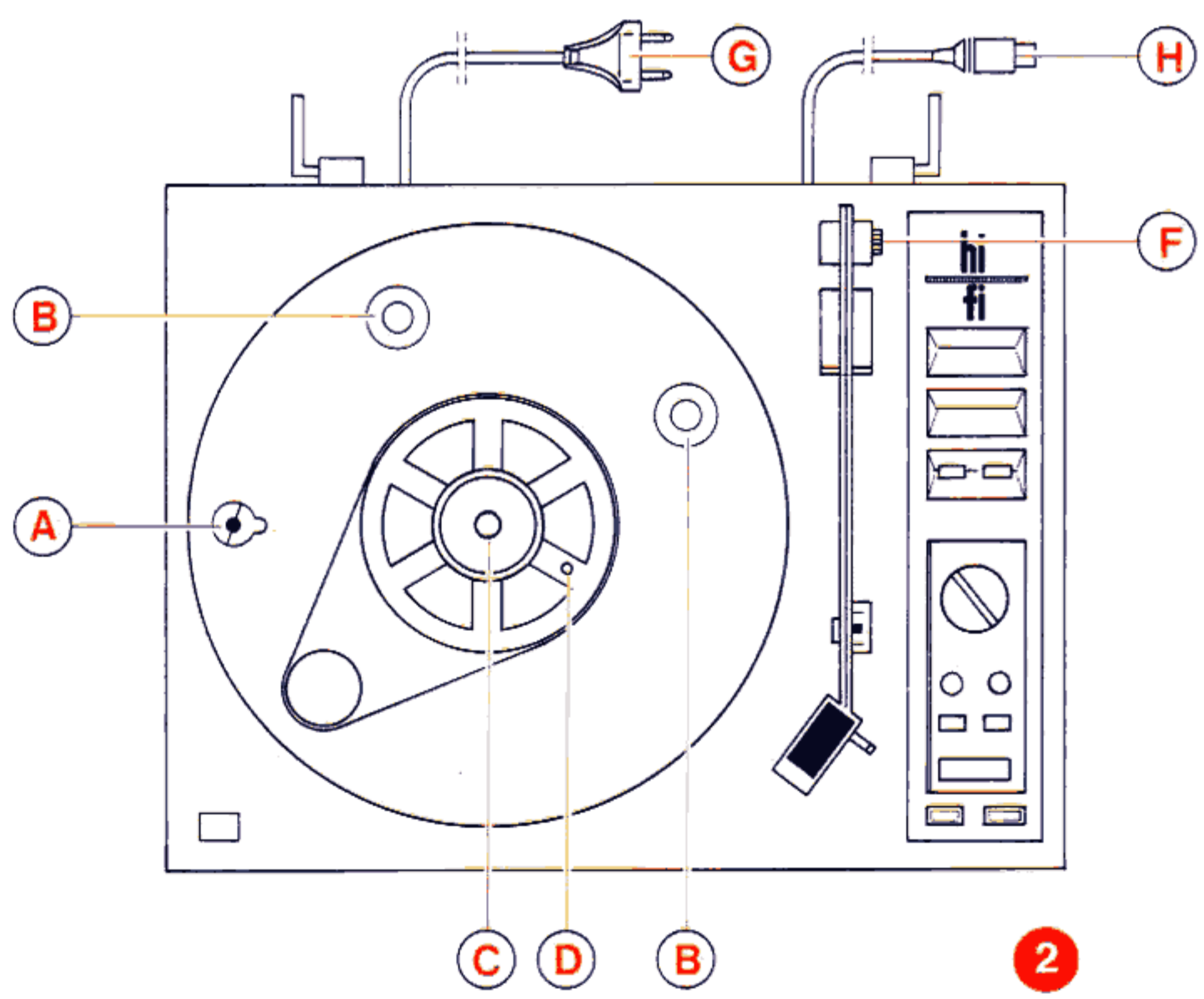

**2**

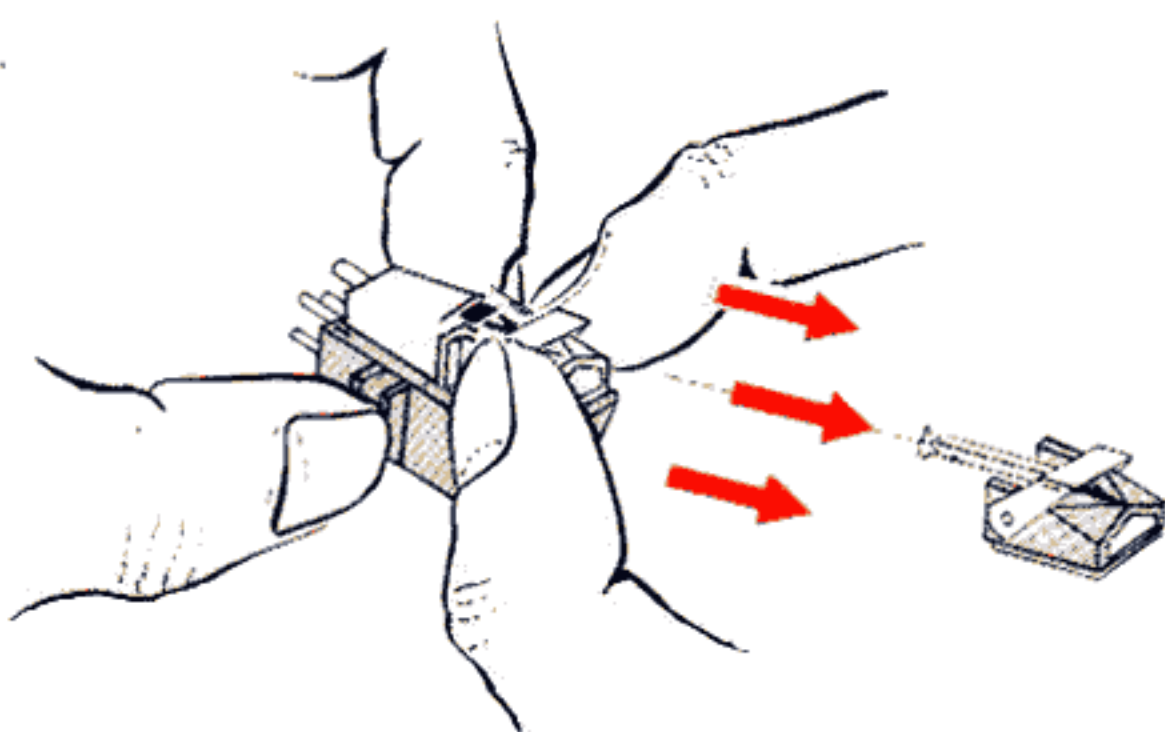
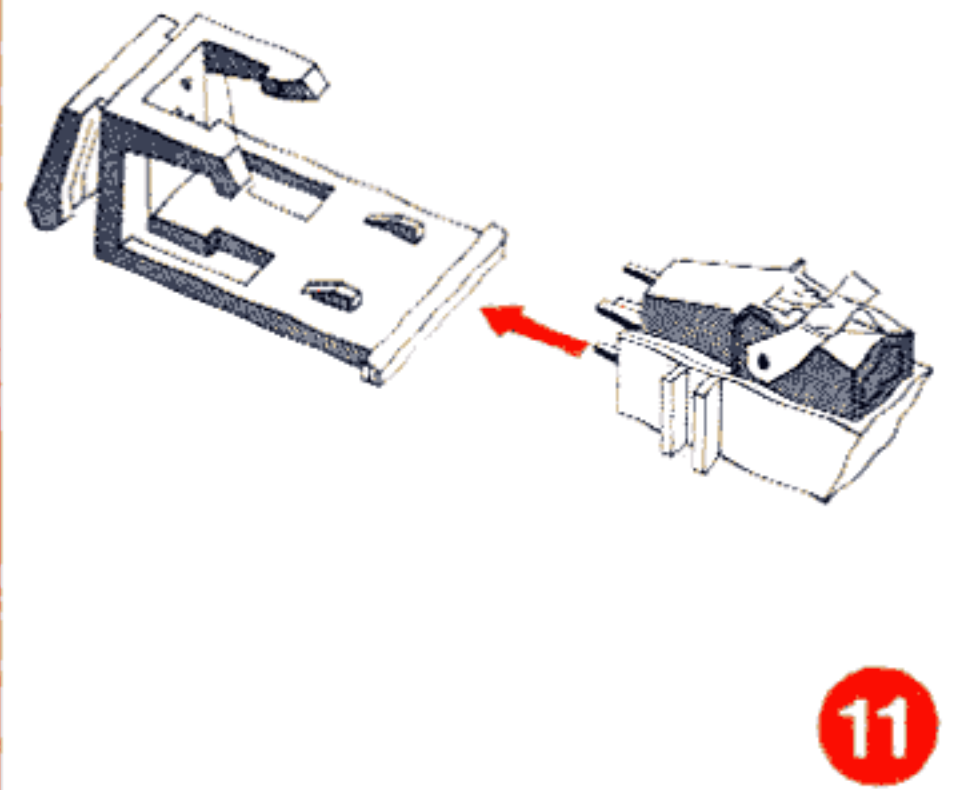
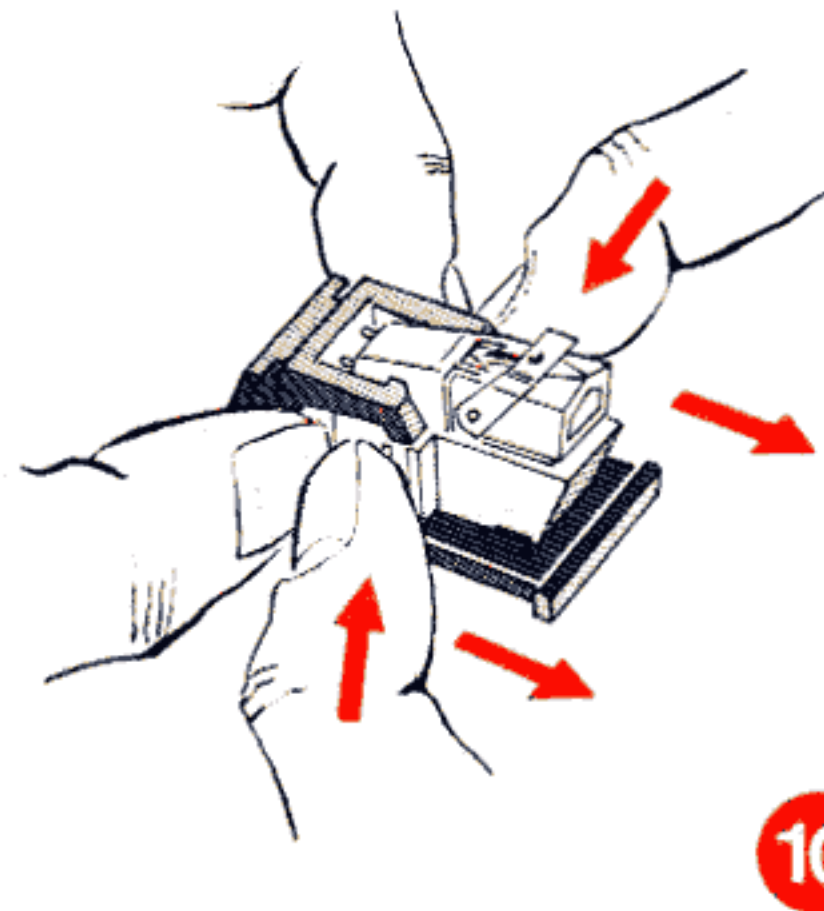
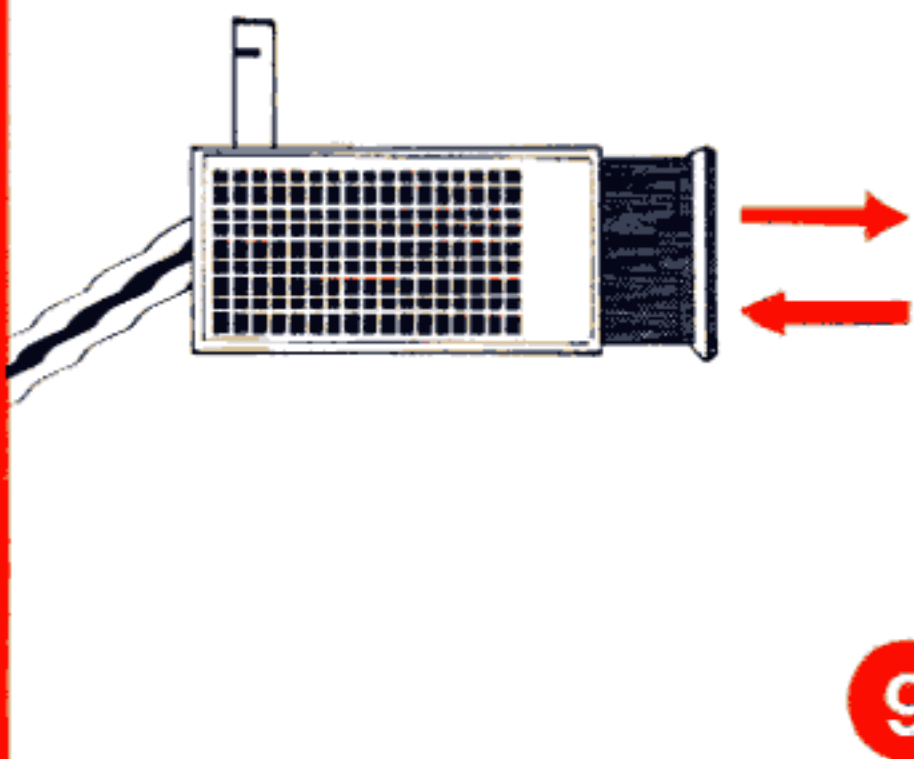
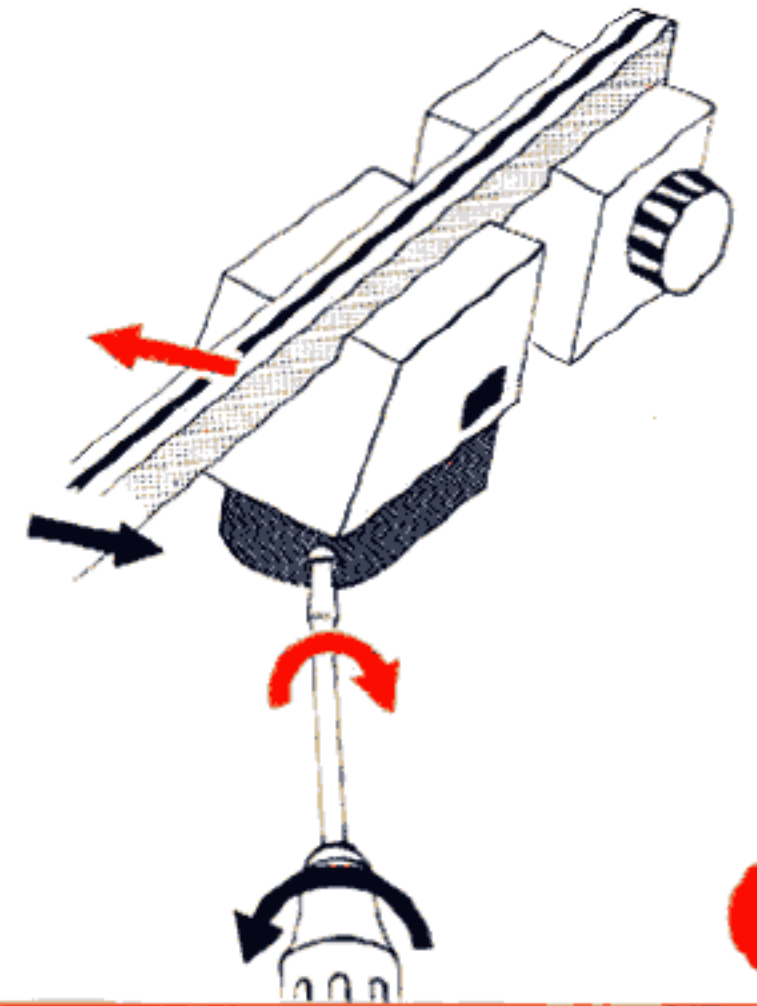
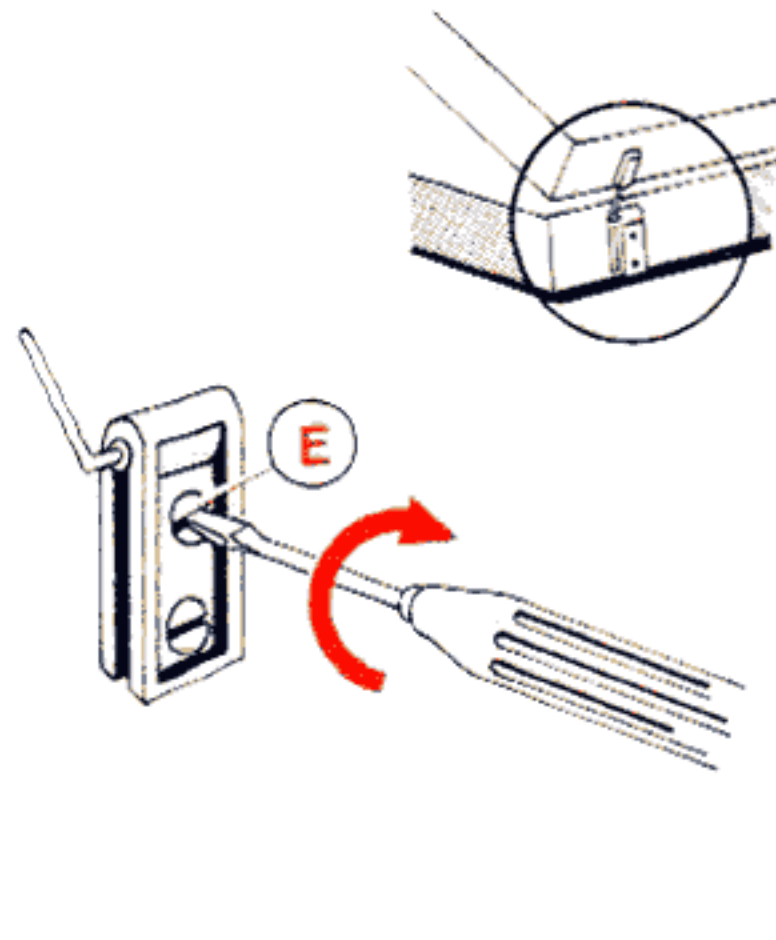
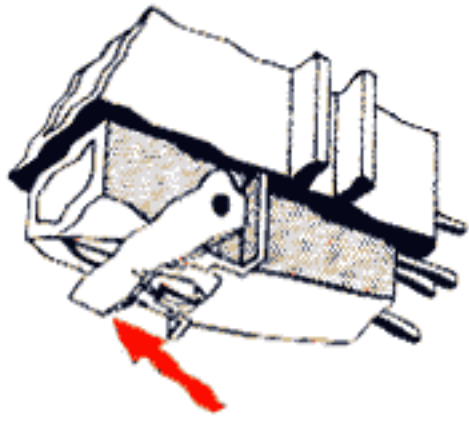
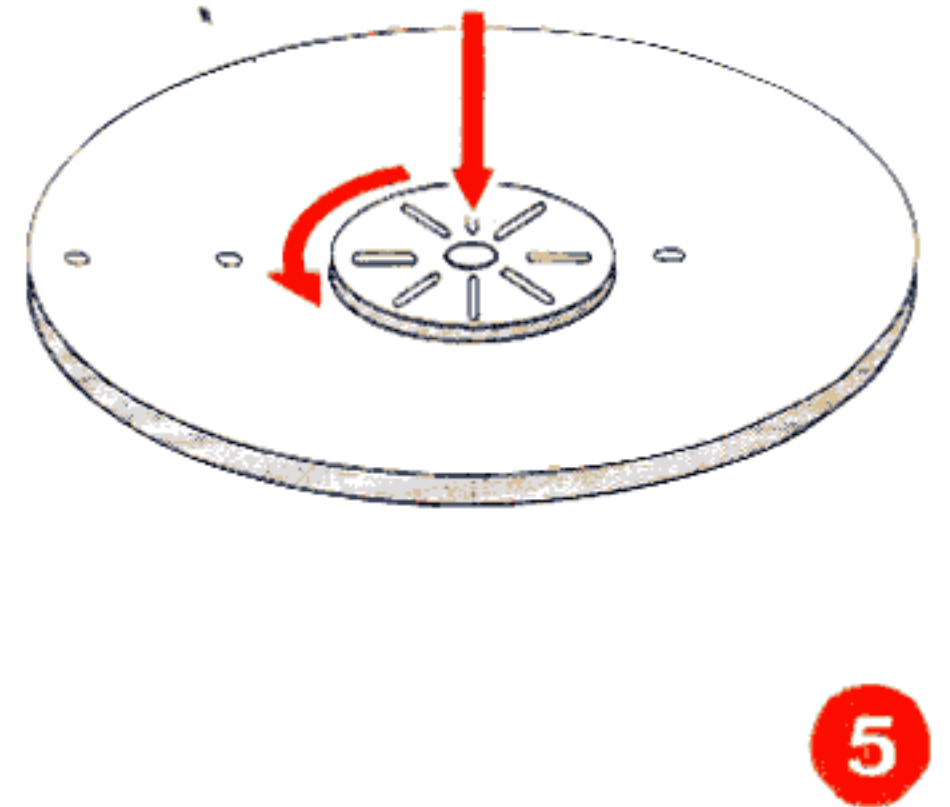
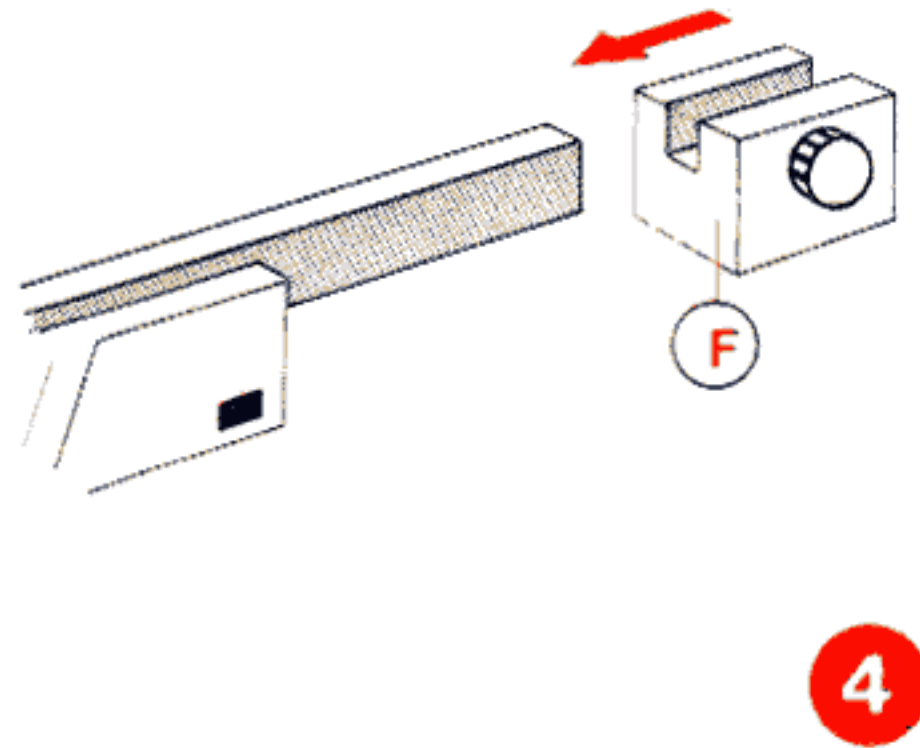
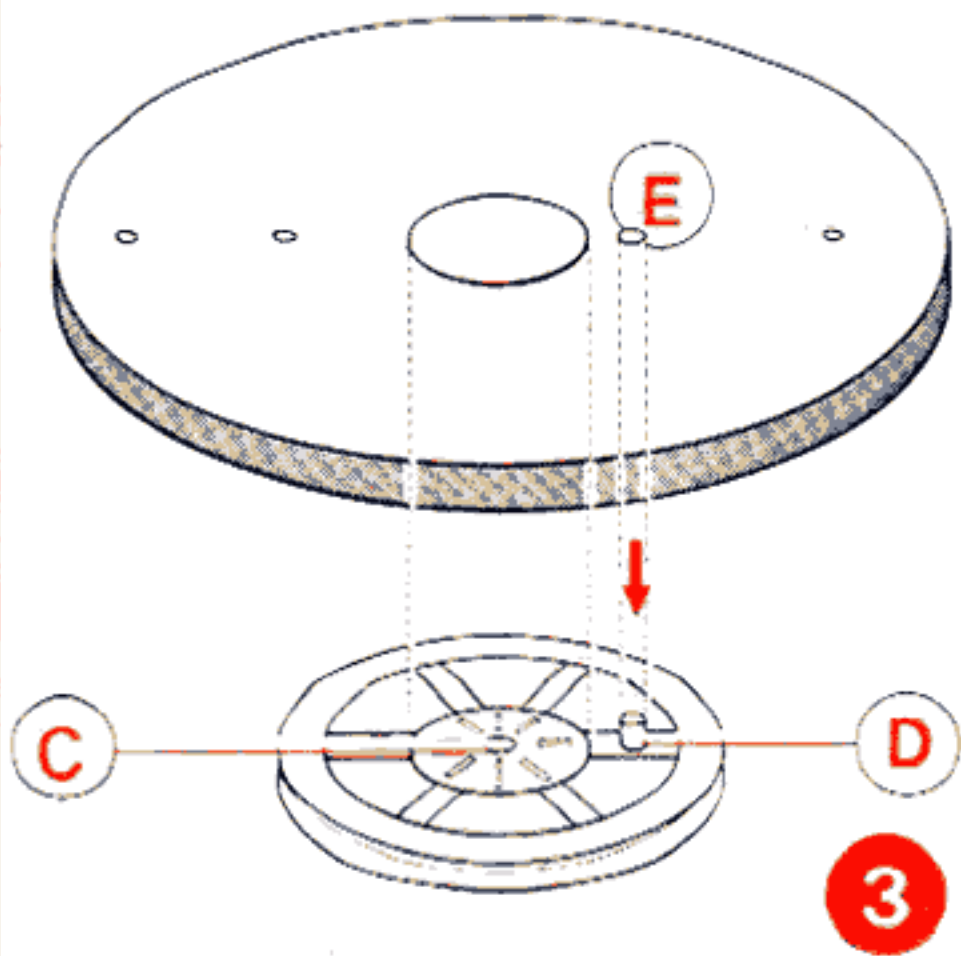

12

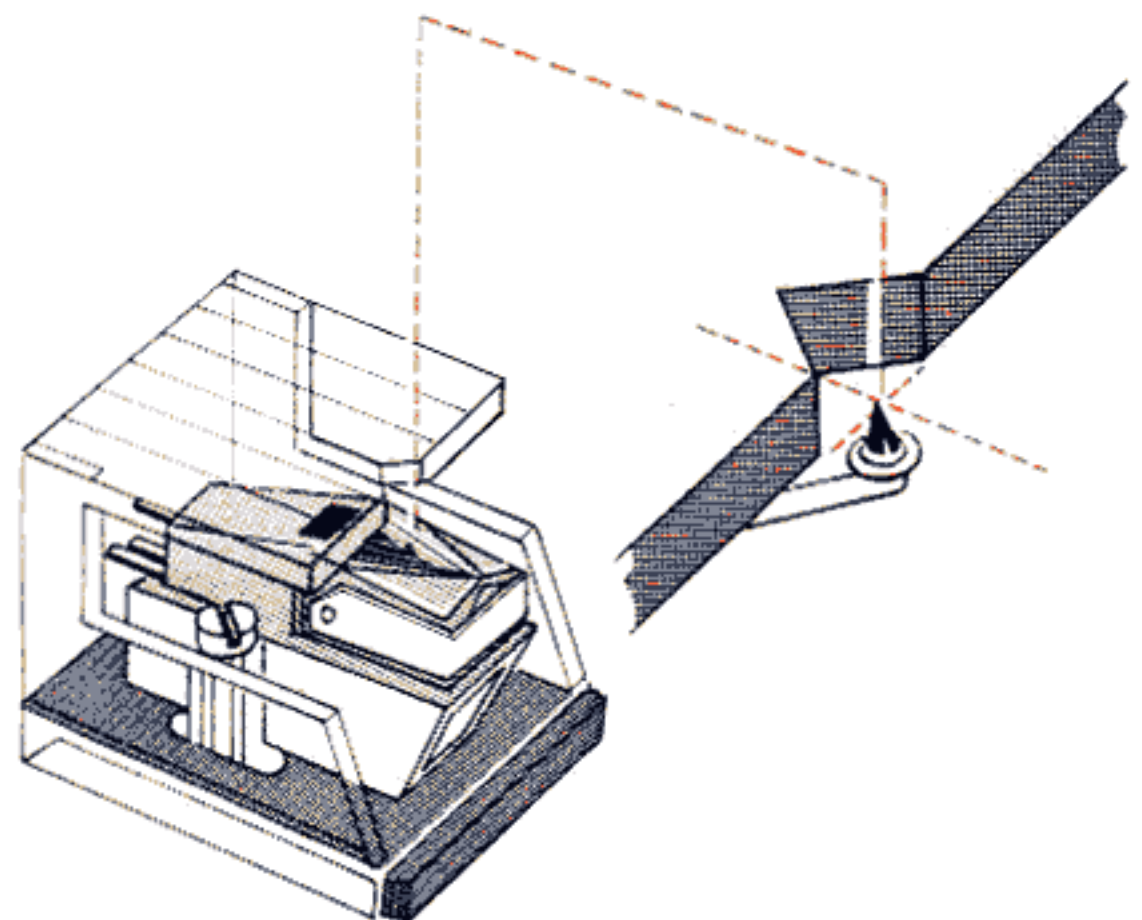

13