

Service Service Service

For repair information of the cassette deck see Service Manual of Car cassette deck TN301NX-227 (for RC169) or CDS-36PS2 (for RC189)

Service Manual

12 V 

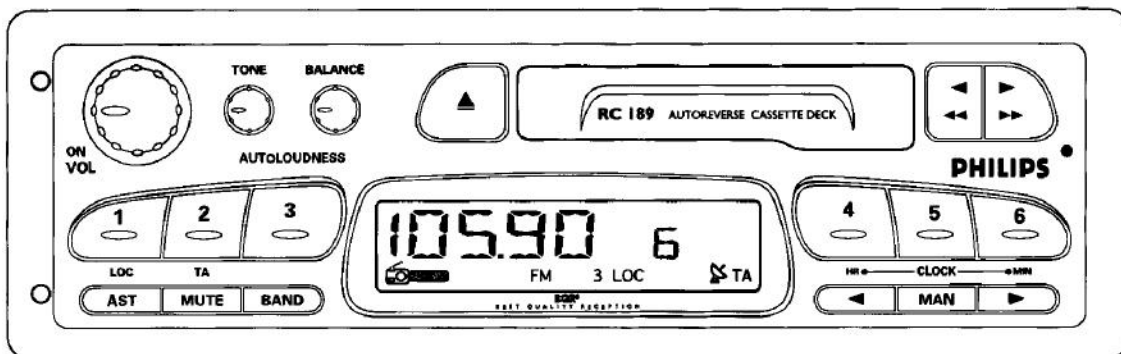
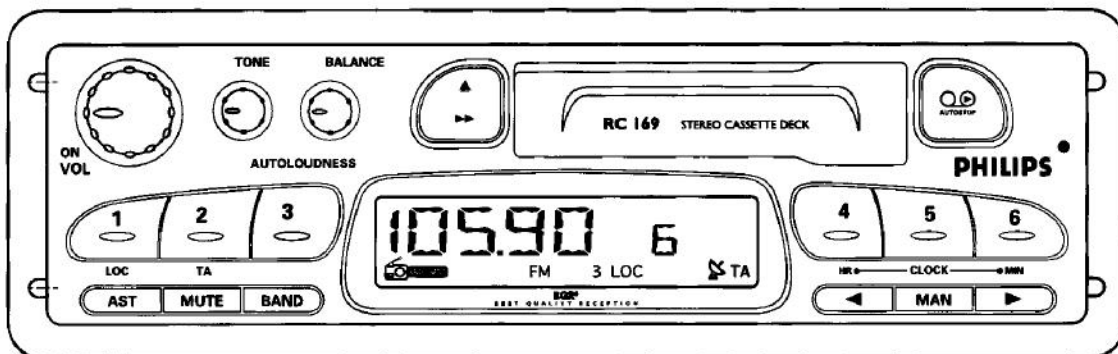

Table of contents	Page
Technical specifications	1
Direction for use	2
Electrical architecture	3
Wiring diagram	4
Circuit diagram Main board & Audio board	5
Service hints	5
Component layout Main board & Audio board	6
Exploded View	7
Electrical Partslist	8

Technical Specifications

General

Power Supply	: 9.5 - 15.6V
Quiescent Current (at 12.6V)	: < 4.0mA
Fuse	: 3A

Radio

FM	: 87.5 - 108MHz, 50kHz step
LW	: 144 - 288kHz, 1kHz step
MW	: 531 - 1629kHz, 9kHz step
Aerial input impedance	: 75 ohm
IF-FM (1/2)	: 10.7MHz/72.2MHz
IF-AM(1/2)	: 10.7MHz/450kHz
α - 3dB	: 6~10 μ V
SDS (10 dB channel separation)	: 150 μ V \pm 3dB
Stereo channel separation	: > 21dB
FM sensitivity for 26dB S/N	: < 4.4 μ V
MW sensitivity for 26dB S/N	: < 22 μ V
LW sensitivity for 26dB S/N	: < 35 μ V

Cassette Deck

Number of tracks	: 2 X 2
Tapespeed	: 4.76 cm/second +3% -1%
Wow and Flutter	: < 0.35%

Amplifier

Output Power (D=10%)	: 2x4.5W \pm 1dB/4 Ω
Loudness (auto)	: 4~8dB at 100Hz
Tone	: 8~24dB at 10kHz



WARNING

All IC's and many semiconductors are susceptible to electronic discharges (ESD). Careless handling during repair can reduce life drastically.

When repairing, make sure that you are connected to the same potential as the mass of the set via a wrist wrap with resistance. Keep components and tools also at this potential.

ESD Equipment :

Anti-static table mat large 1200x650x1.25mm	4822 466 10953
small 600x650x1.25mm	4822 466 10958
Anti-static wrist band	4822 395 10223
Connection box (1M Ω)	4822 320 11307
Extendible cable (to connect wrist band to conn. box)	4822 320 11305
Connecting cable (to connect table mat to conn. box)	4822 320 11306
Earth cable (to connect any product to mat or box)	4822 320 11308
Complete kit ESD3 (combining all above products)	4822 310 10671
Wristband tester	4822 344 13999

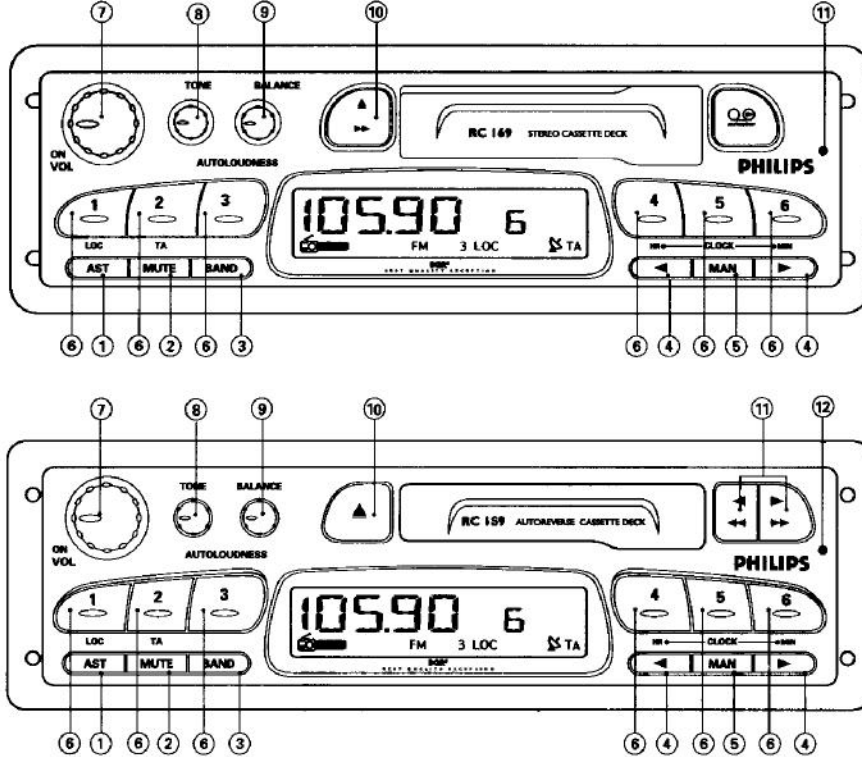

SUMMARY OF CONTROLS

- ① Auto Store (AST) / Local/Distant mode (LOC)
- ② Mute (MUTE) / Traffic Announcement (TA)
- ③ Band (BAND)
- ④ Search tuning and manual tuning (◀ and ▶) / Clock adjust (HR and MIN)
- ⑤ Manual tuning on/off (MAN) / Clock key (CLOCK)
- ⑥ Presets (1-6)
- ⑦ On/off-Volume (ON-VOL)
- ⑧ Tone (TONE)

For RC169 only

- ⑨ Balance (BALANCE)
- ⑩ Cassette eject (▲) and fast forward (▶▶)
- ⑪ Blinking LED

For RC189 only

- ⑨ Balance (BALANCE)
- ⑩ Cassette eject (▲)
- ⑪ Fast forward and rewind (◀◀ and ▶▶) / Reverse tape direction (◀▶)
- ⑫ Blinking LED

CLOCK

The radio incorporates a 24 hours clock.

Clock display

- Press the CLOCK key for at least 2 seconds (until you hear a beep).
- The display shows the time. After any tuning operations, the frequency will be displayed for about 10 seconds.

Setting the clock

- While the display shows the clock time, you can adjust time setting by pressing a 2-key combination as follow:
 - CLOCK+ ◀ to adjust hours
 - CLOCK+ ▶ to adjust minutes
- To switch back to frequency display, press the CLOCK key for about 2 seconds (until you hear a beep).

TRAFFIC ANNOUNCEMENTS ON FM

You can switch on the TA mode to give priority to Traffic Announcements. Traffic Announcements can then interrupt cassette playback or mute.

Volume level for Traffic Announcements

If you only want to hear Traffic Announcement.

- Tune to your preferred TA-station.
- Adjust the desired volume.
- Briefly press 'MUTE'.

Switch on TA mode (so that Traffic Announcements have priority)

- Select a FM band with BAND key.
- Press the TA key for at least 2 seconds (until you hear a beep). The display shows 'TA'.
- If the tuned station does not enable the reception of Traffic Announcements, the display shows 'NO TA'. The radio automatically searches an appropriate station.
- You will hear the Traffic Announcements when broadcast.
- If you play a cassette, the radio will interrupt cassette playback each time a Traffic Announcement is broadcast.

Interrupting a Traffic Announcement

If you do not wish to continue listening to a particular Traffic Announcement, you can interrupt it without switching off the TA mode.

- Briefly press the 'MUTE' to silence the set or,
- Press the TA key for at least 2 seconds (until you hear a beep). The set will return to its previous operating mode.

Switching off TA mode (so that Traffic Announcements do not have priority)

- Press the TA key for at least 2 seconds (until you hear a beep). TA disappears from the display.

Note:

- If the TA mode is switched on, search tuning only selects stations which enable the reception of Traffic Announcements.
- If the tuned station becomes too weak to enable the set to provide the RDS traffic service, you will hear beeps repeated at intervals. Use search tuning to find another station.

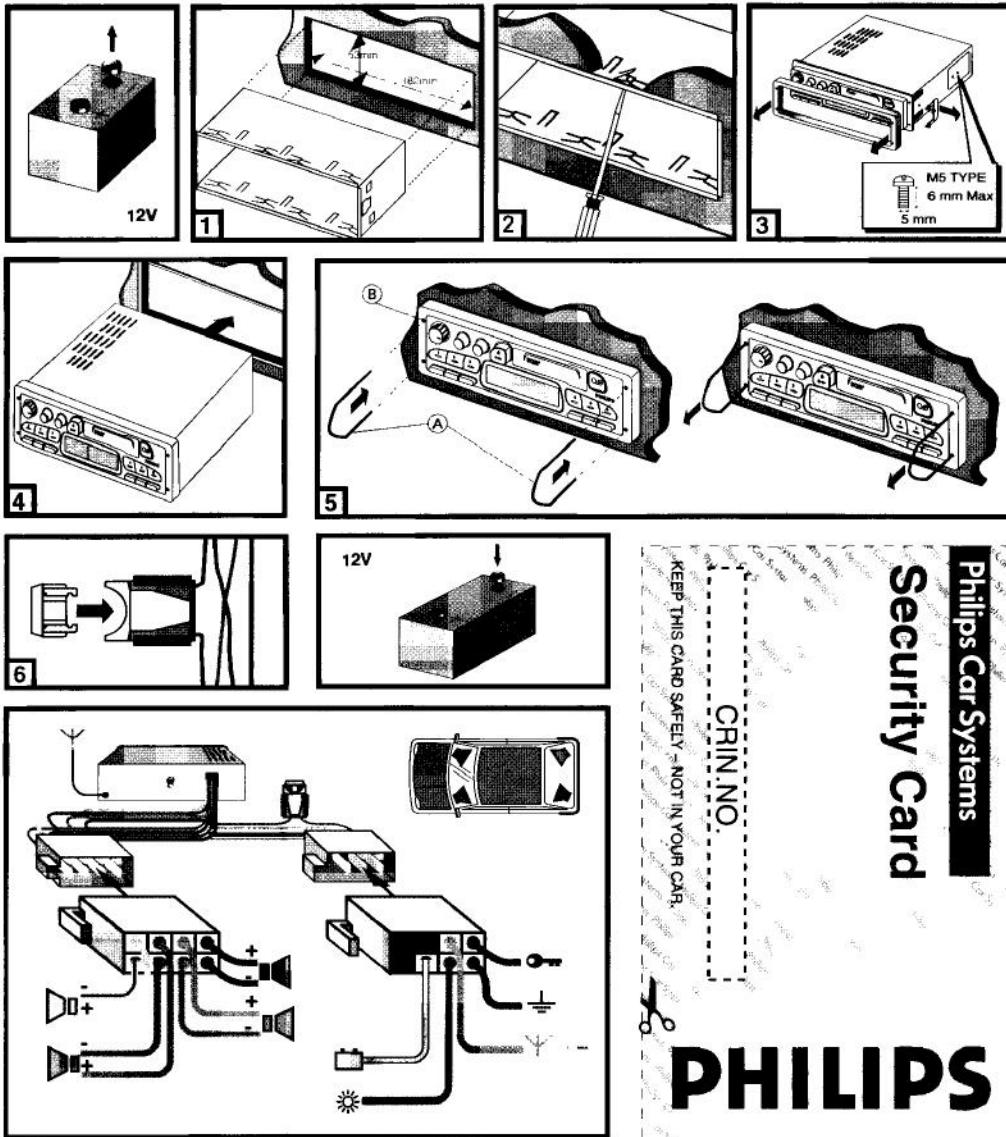

MOUNTING INSTRUCTION

Voltage and polarity: The set must be connected to a 12V car battery with negative terminal to earth (car chassis).

Warning: To prevent short-circuiting, disconnect the negative car battery terminal until the set has been mounted and connected.

INSTALLING METAL SLEEVE

- Install the metal sleeve in the dashboard (Fig.1).
- Fix metal sleeve into place by pressing the metal tags outwards using a screwdriver (Fig.2).
- If installing this set in a Japanese car, use the side holes which align with the holes in the side of the mounting opening (Fig.3).
- Only use M5 screws that are not longer than 6mm. If necessary, remove the trimplate around the front panel and the side springs (Fig.3).

POWER SUPPLY AND LOUDSPEAKER

If your car is equipped with ISO connectors, simply insert them in the connectors of the car radio. If not, you can use an adaptor cable (Refer to the table at the end of this booklet).

Connection details

Power supply

- **Red lead :** Connect to a switched 12V supply (switched on/off by car ignition).
- **Yellow/red lead :** Connect to a permanent 12V supply. This supply is needed for the set's memory.
- **Grey lead :** Connect to a 12V supply. When the car headlamps are switched on, the rotary knobs of radio are illuminated (even when the radio is switched off).
- **Brown lead :** Connect to earth (car chassis).

Loudspeakers (only use 4ohm loudspeakers)

- Do not connect any of the loudspeaker leads to earth or directly to a booster/amplifier.
- **Connecting 4 loudspeakers**

	Front	Rear
Left+	Green	Brown
Left-	Green/black	Brown/black
Right+	Grey	Blue
Right-	Grey/black	Blue/black

OTHER CONNECTIONS

- **Automatic Aerial:** This radio can provide a 12V signal for the control of an automatic motor aerial or the supply of an electronic aerial by connection .
- Do not use this connection for the supply lead of the aerial motor!

MOUNTING RADIO (Figs.4)

- Insert aerial plug into aerial socket (good reception is only possible with a good aerial).
- Slide the radio into the metal sleeve until the springs at either side of the radio snap into the openings of the sleeve .
- Finally reconnect the negative car battery terminal.

REMOVING RADIO (using the two U- brackets supplied)

- Insert both U-brackets (A) into the holes (B) until they lock. Pull out the radio (Fig.5).

REPLACING FUSE

- Use a 3A blade-type fuse (Fig.6).

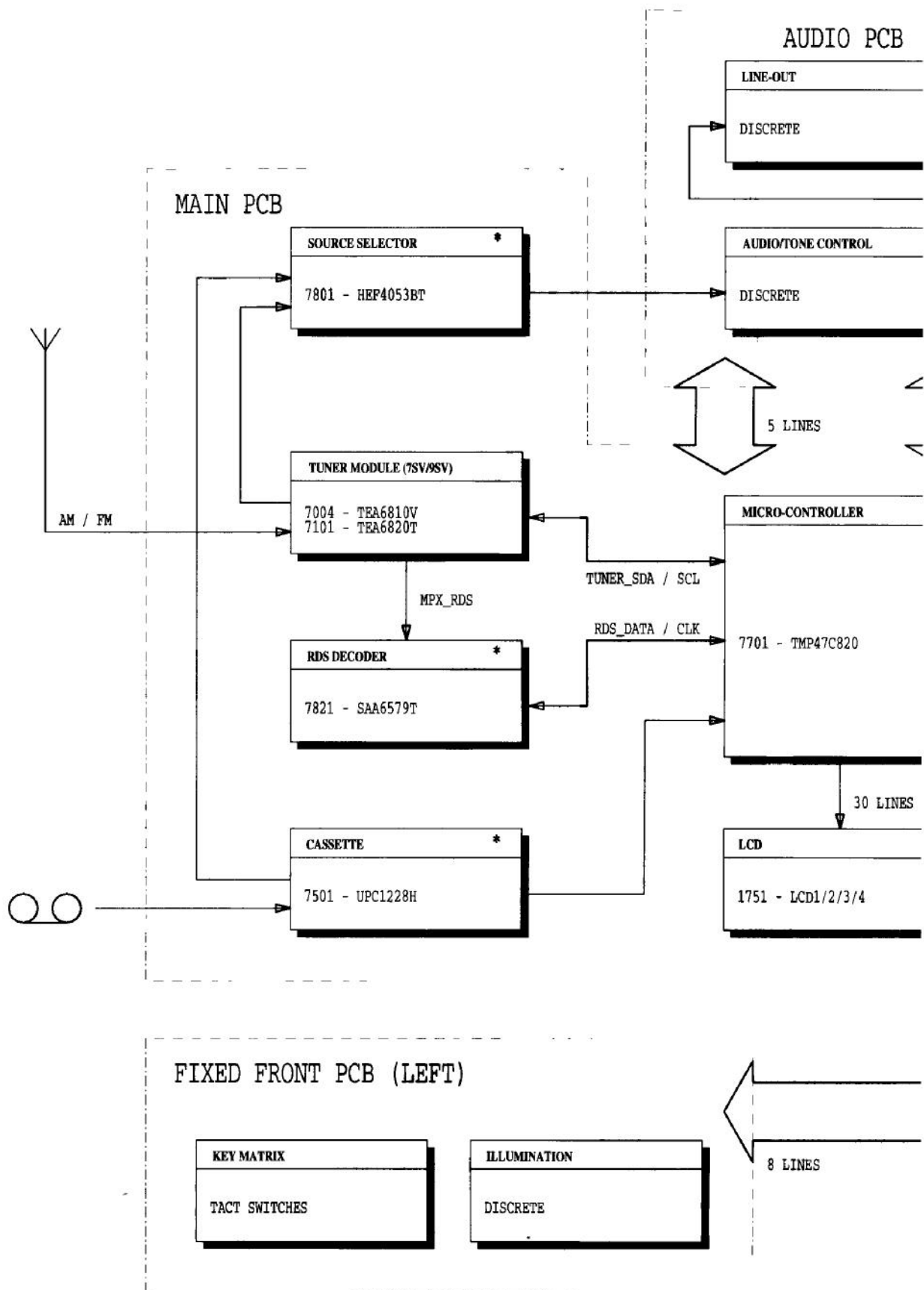

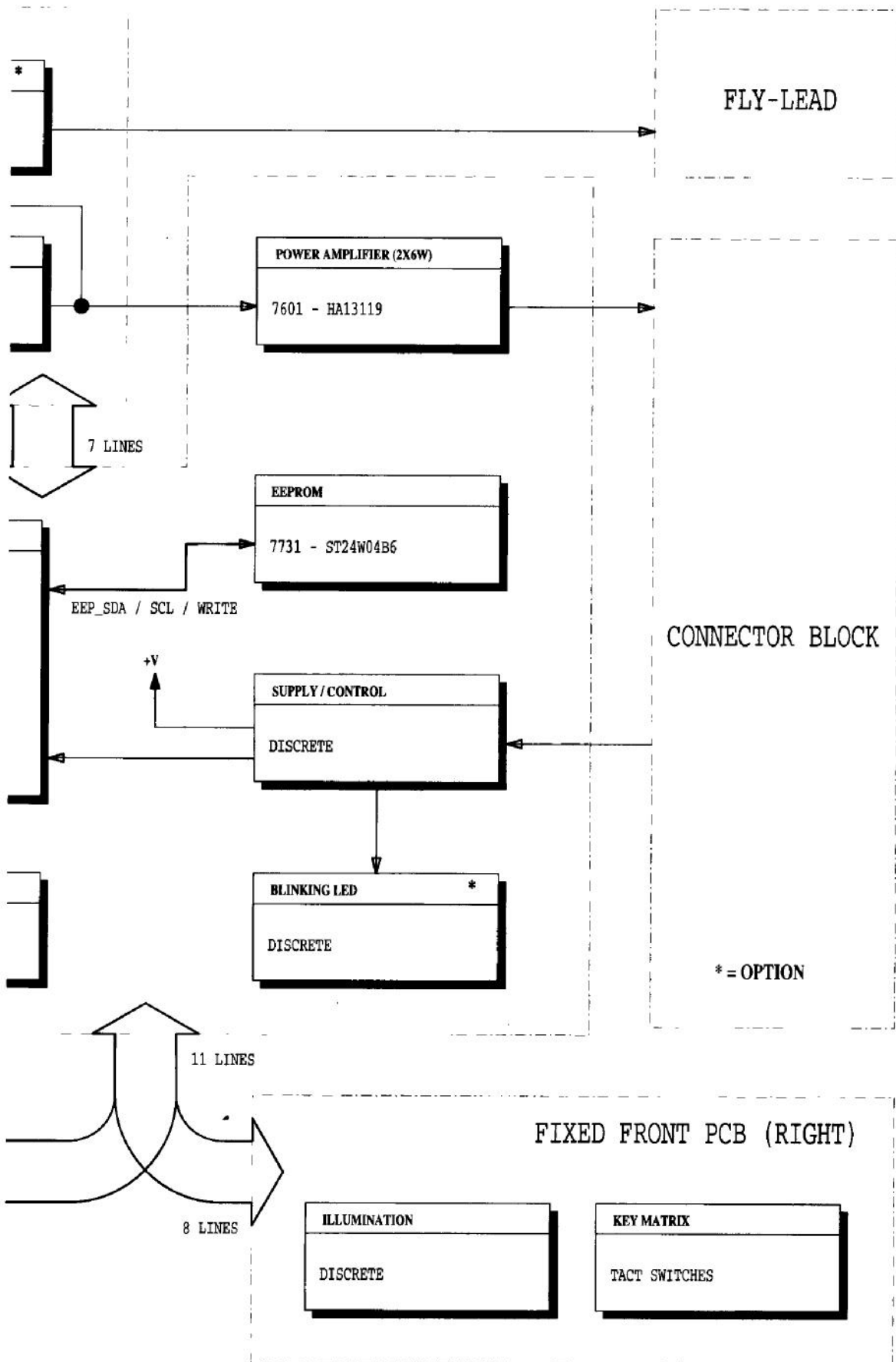

PART B : WIRING DIAGRAM

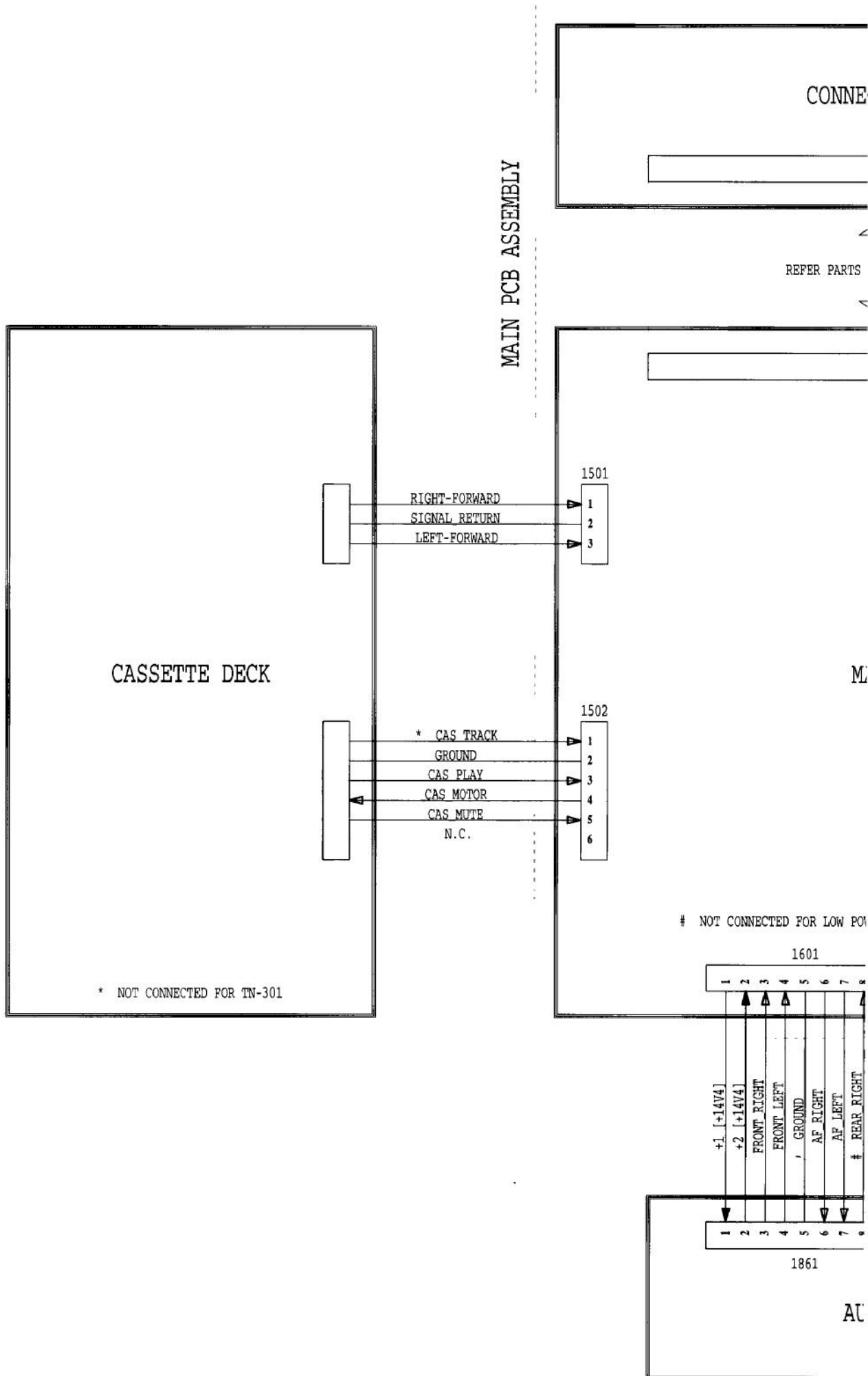

CTOR BLOCK

1900

1 & 3 FOR CONNECTIONS

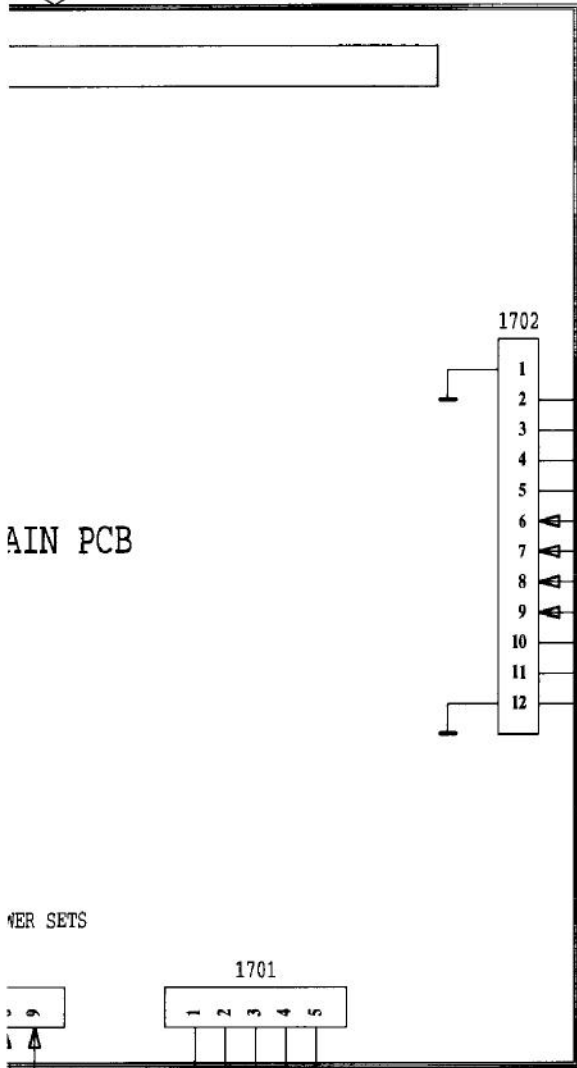

MAIN PCB

REAR SETS

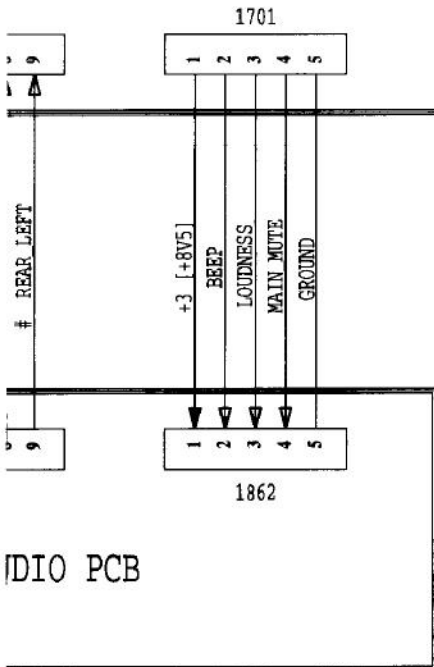

RADIO PCB

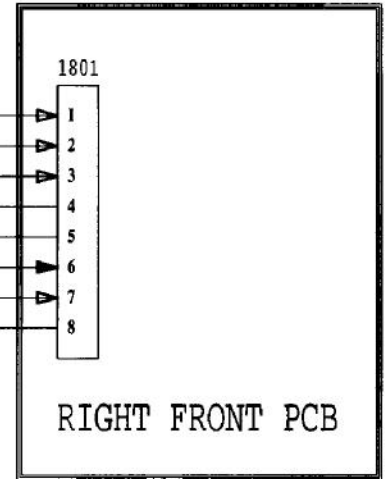

RIGHT FRONT PCB

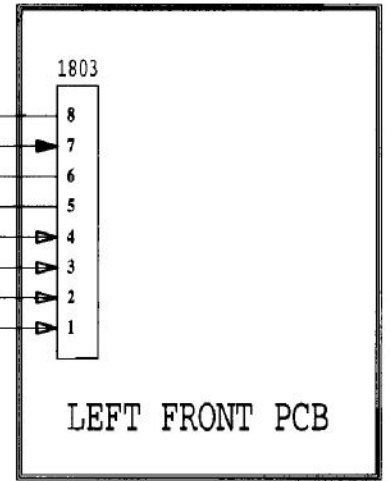

LEFT FRONT PCB

PART 3 : SUPPLY/CONTROL & BLINKING LED (MAIN PCB)

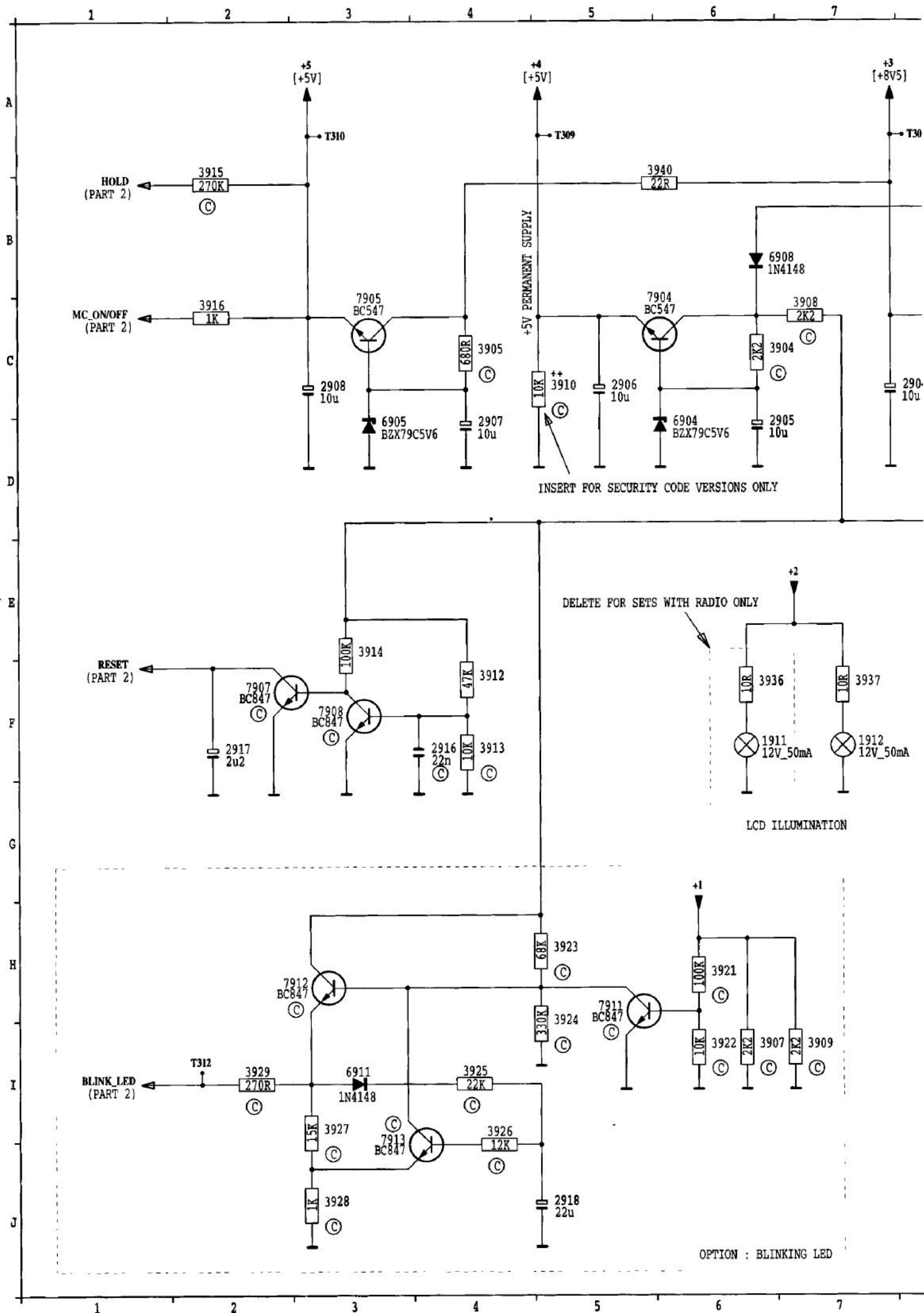

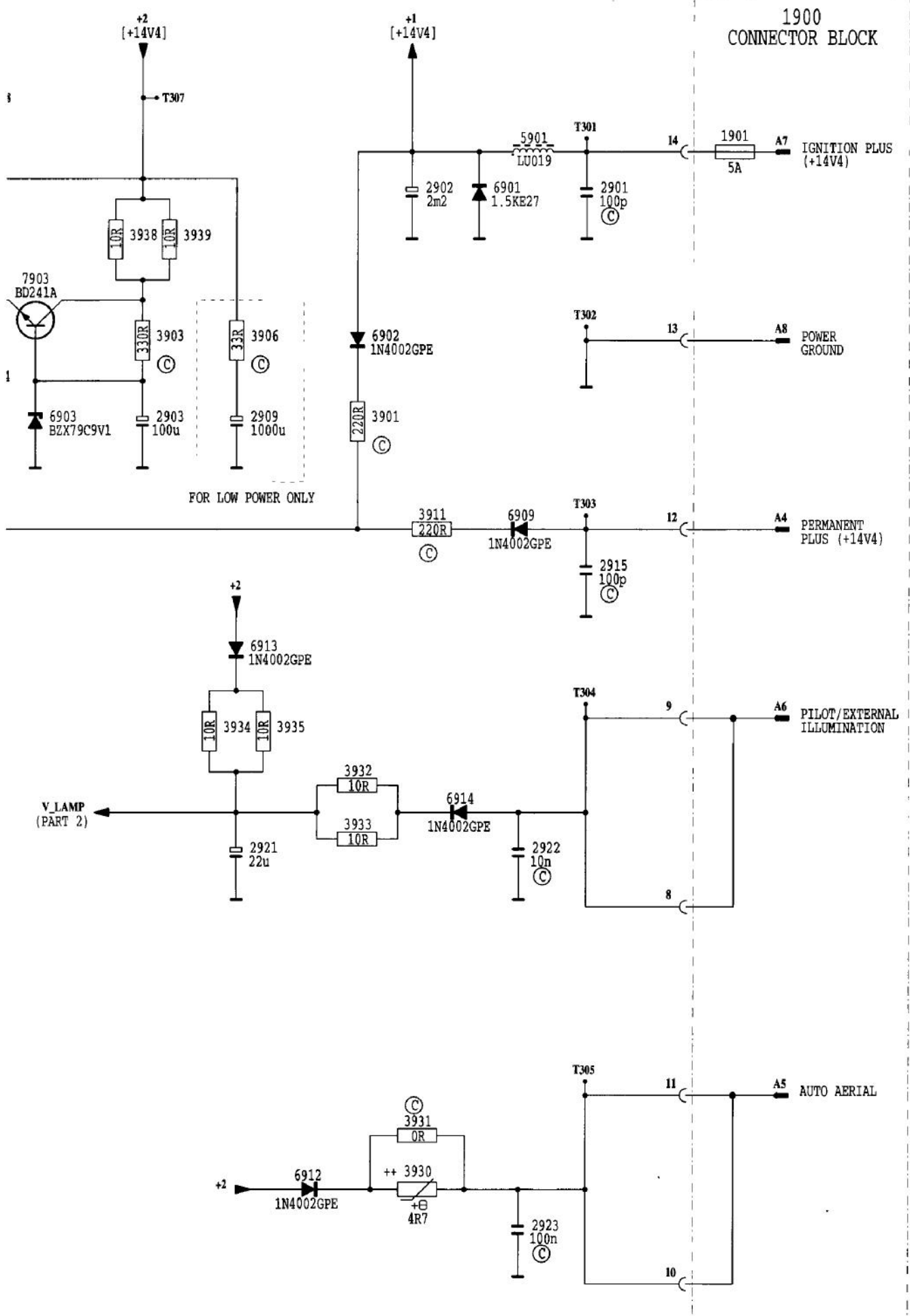

1900	A13
1911	F 6
1912	F 7
2901	B12
2902	B11
2903	D 9
2904	C 8
2905	D 7
2906	C 5
2907	D 4
2908	C 3
2909	D10
2915	E12
2916	F 4
2917	F 2
2918	J 5
2921	G10
2922	G12
2923	J12
3901	D11
3903	C 7
3904	C 7
3905	C 4
3906	C10
3907	I 6
3908	C 7
3909	I 7
3910	C 5
3911	D11
3912	F 4
3913	F 4
3914	E 3
3915	A 2
3916	C 2
3921	H 6
3922	I 6
3923	H 5
3924	I 5
3925	I 4
3926	I 4
3927	I 3
3928	J 3
3929	I 2
3930	I11
3931	I11
3932	F10
3933	G10
3934	F 9
3935	F10
3936	F 6
3937	F 7
3938	B 9
3939	B 9
3940	A 6
5901	B12
6901	B11
6902	C11
6903	D 8
6904	D 6
6905	D 3
6908	B 7
6909	D12
6911	I 3
6912	I10
6913	E10
6914	F11
7903	C 8
7904	C 5
7905	C 3
7907	F 2
7908	F 3
7911	H 3
7912	H 3
7913	J 3

++ ITEM NOT USED - PROVISION IN PCB LAYOUT ONLY

PART 4 : KEY MATRIX & ILLUMINATION (FRONT PCB)

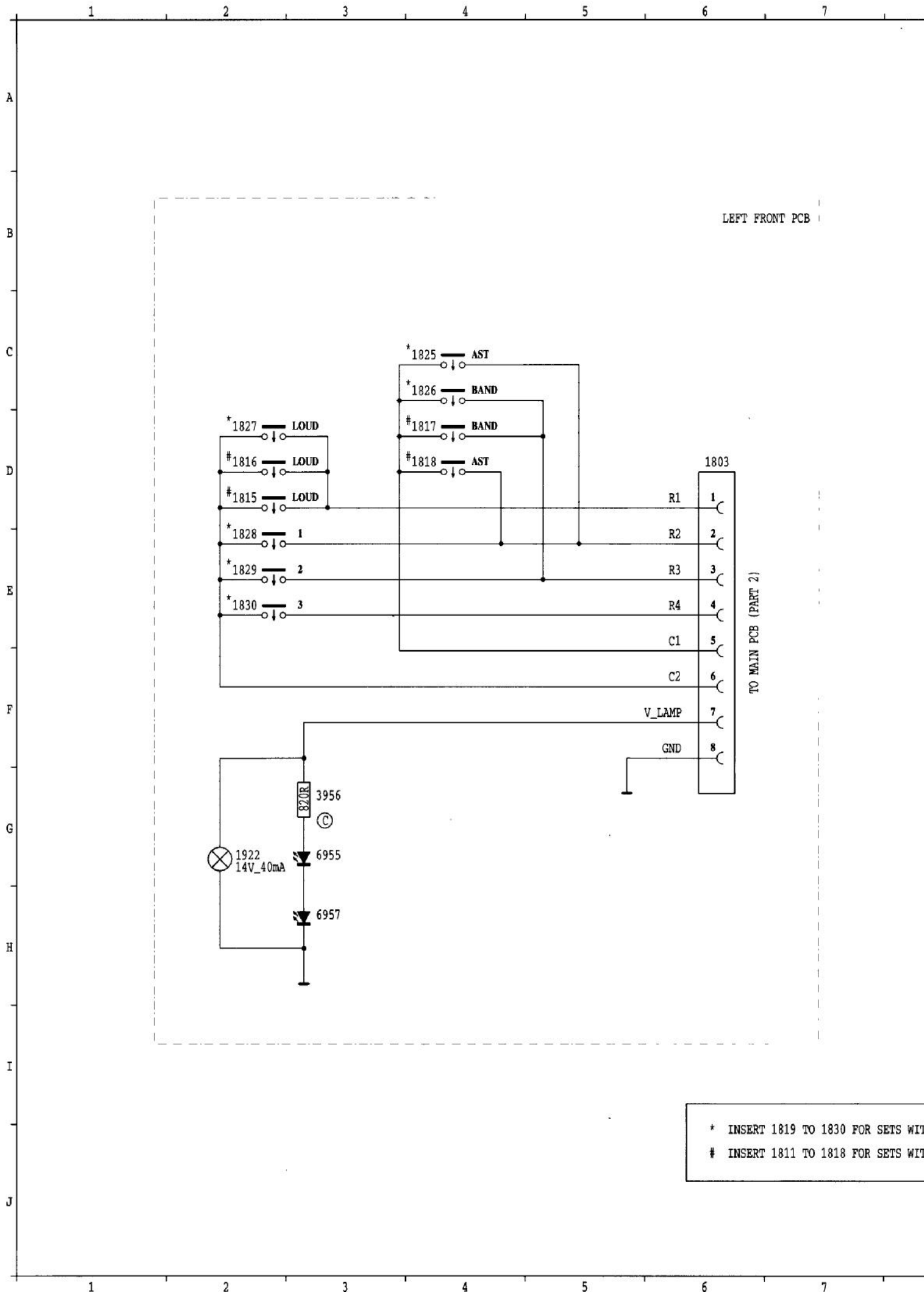

* INSERT 1819 TO 1830 FOR SETS WII
 # INSERT 1811 TO 1818 FOR SETS WII

RIGHT FRONT PCB

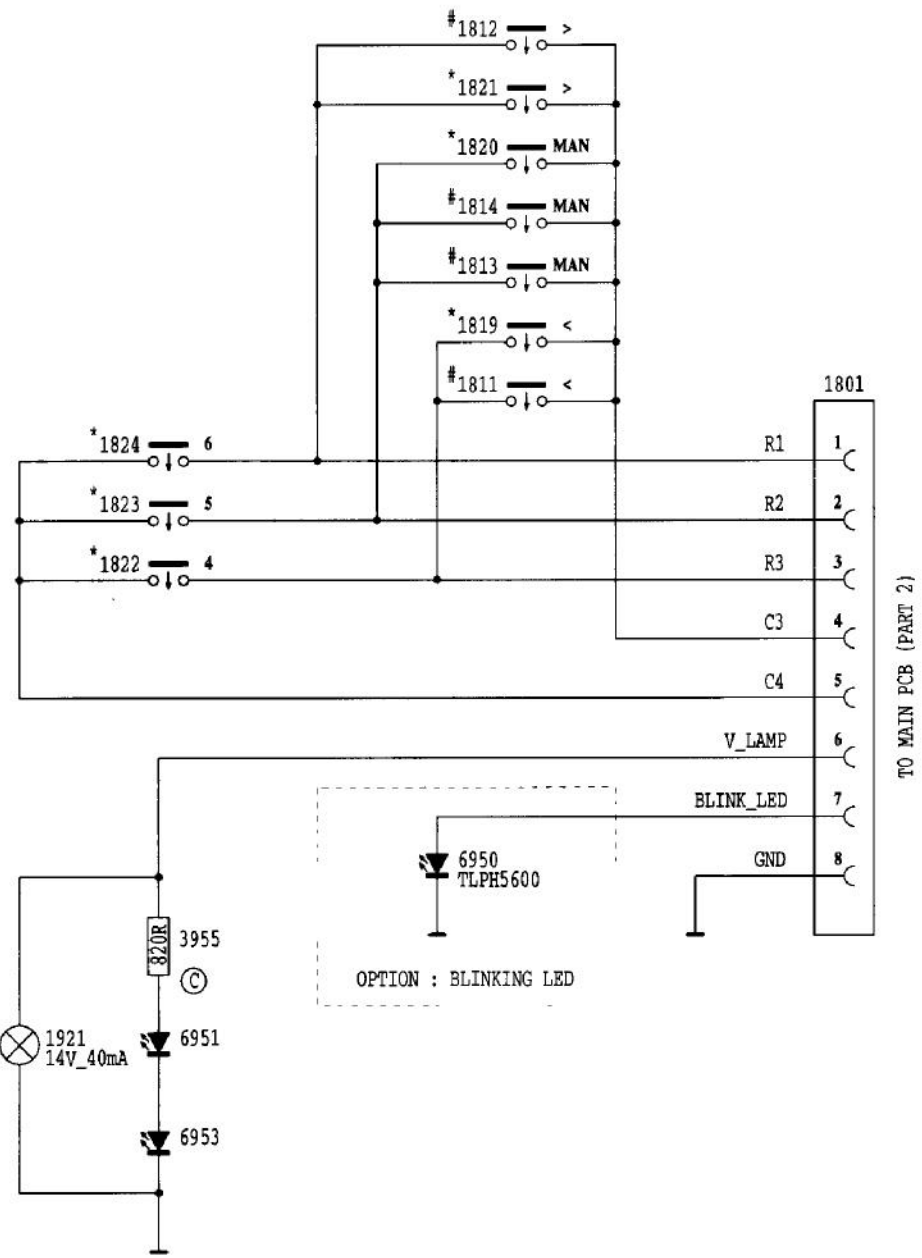

1801	D13
1803	D 6
1811	D11
1812	B11
1813	C11
1814	C11
1815	D 2
1816	D 2
1817	D 4
1818	D 4
1819	D11
1820	C11
1821	B11
1822	E 9
1823	E 9
1824	D 9
1825	C 4
1826	C 4
1827	D 2
1828	E 2
1829	E 2
1830	E 2
1921	G 9
1922	G 2
3955	G10
3956	G 3
6950	F11
6951	G10
6953	H10
6955	G 3
6957	H 3

A
B
C
D
E
F
G
H
I
J

H STATION PRESETS
HOUT STATION PRESETS

PART 5 : TONE CONTROL (AUDIO PCB)

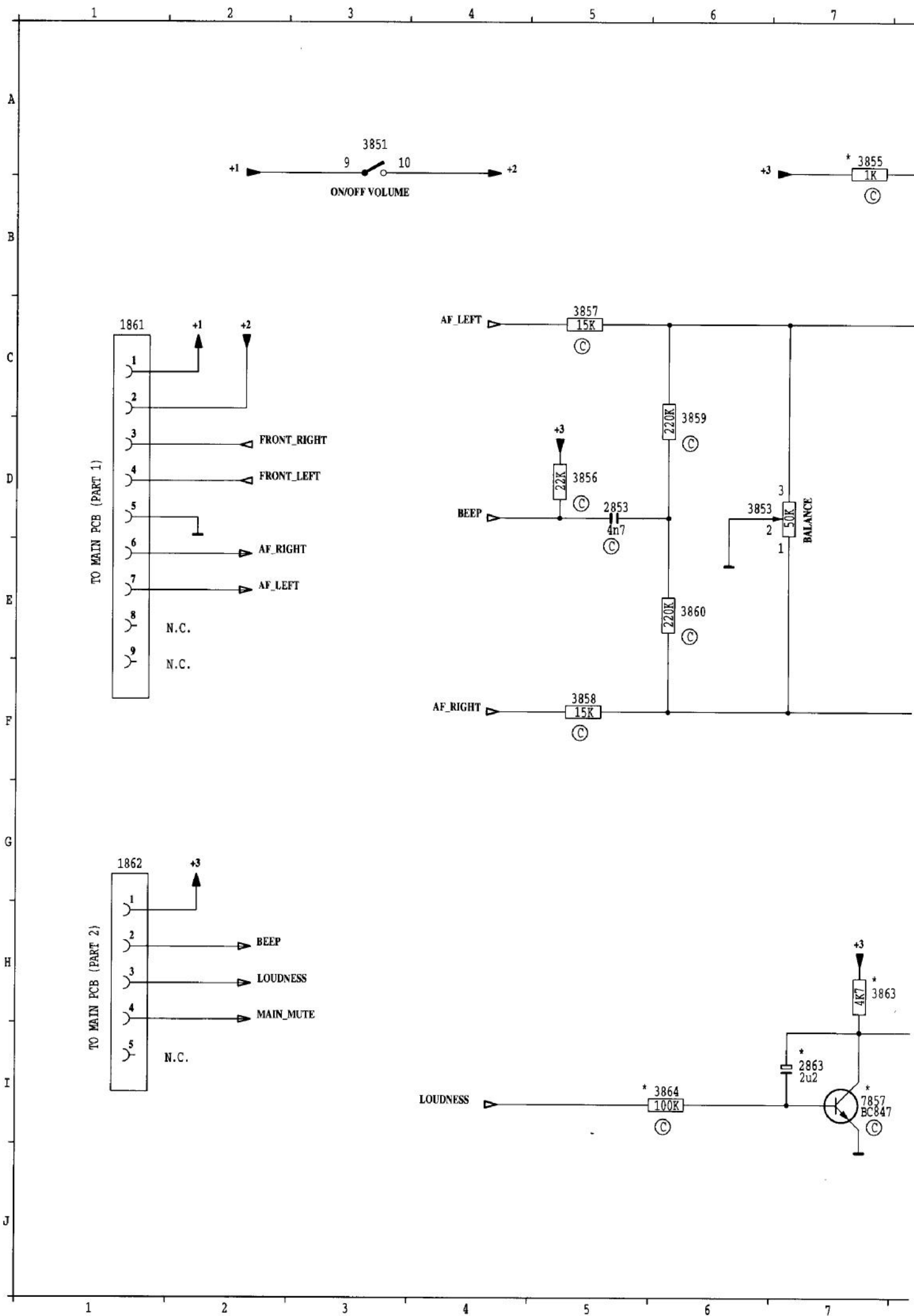

1861 C
1862 G
2852 W
2853 D
2854 C
2855 C
2856 F
2857 D
2858 G
2859 H
2860 H
2861 C
2862 F
2863 I
2864 I
2865 F
2866 F
2867 J
3849 G
3850 D
3851 D
3851 A
3851 G
3852 D
3852 G
3853 D
3855 A
3856 D
3857 C
3858 F
3859 D
3860 E
3863 H
3864 I
3865 C
3866 F
3867 D
3868 G
3869 E
3870 H
3871 H
3872 U
3877 H
3878 I
6851 D
6852 G
6854 I
6855 E
7853 E
7854 H
7855 H
7856 I
7857 I

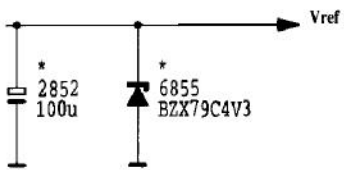

* DELETE IN CASE OF AUTO LOUDNESS
INSERT/VALUE CHANGE IN CASE OF AUTO LOUDNESS

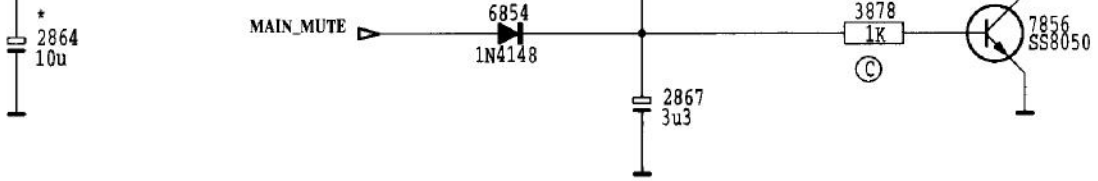
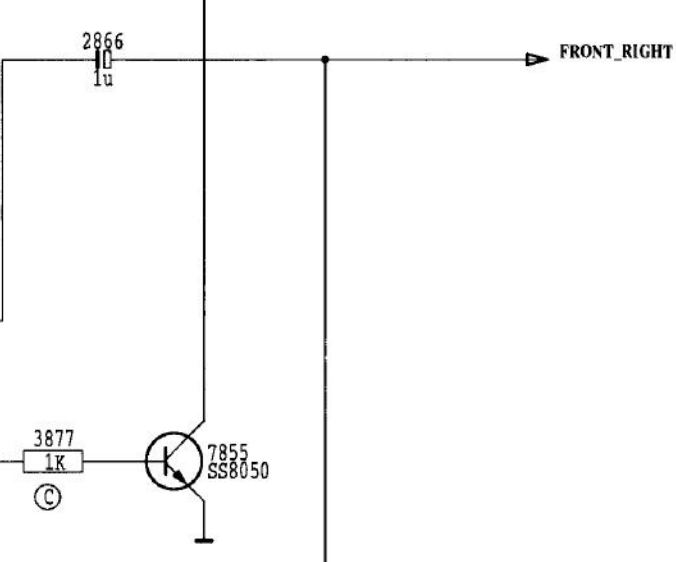
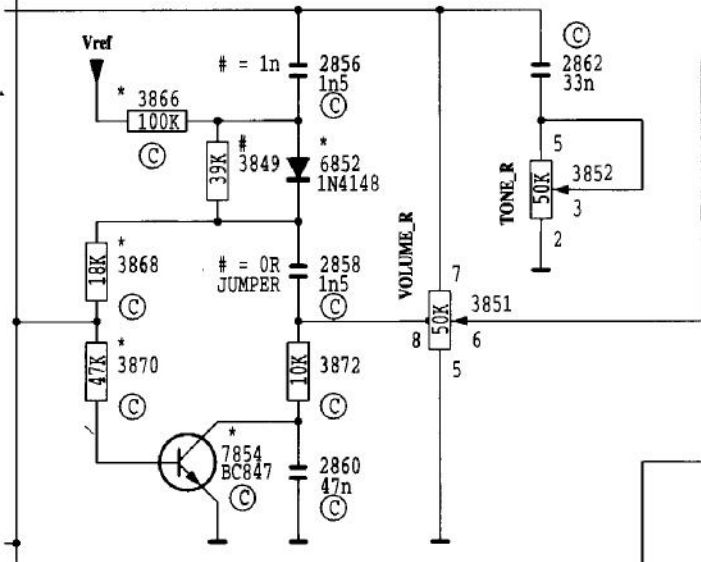
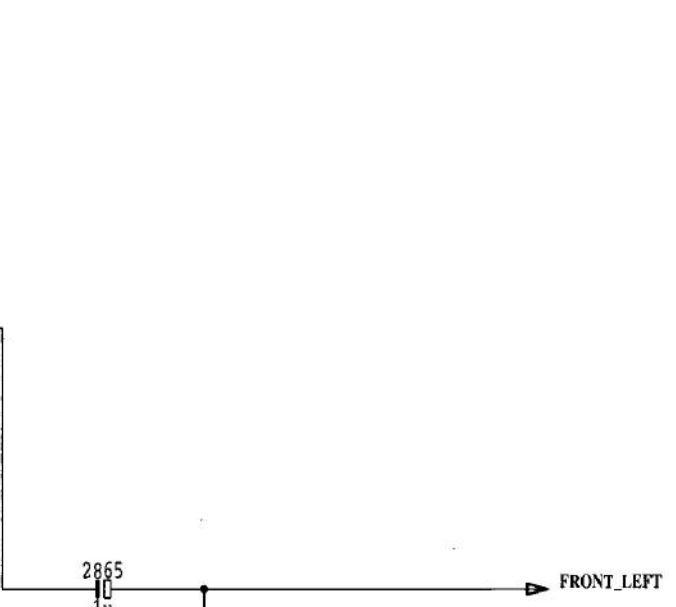
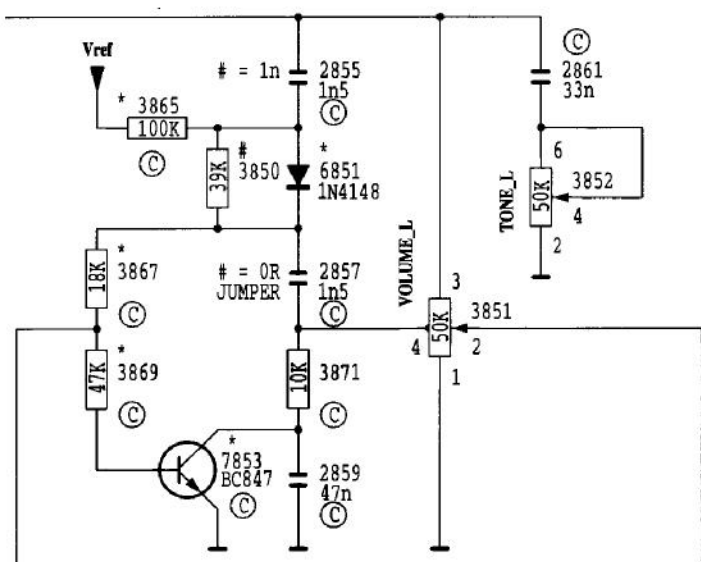

ADDITIONAL FUNCTION CHECK:

Item	Input	Output
External illumination +	Set off Inject +12V at pin A6	Power pilot light turns ON.
Auto Antenna	Connect a resistor of 25Ω from A5 to GND. Switch on set.	Voltage drop between pin A7 & A5 < 1V.
Line-out (only for RC188)	Tuner set to FM mode, 97MHz Inject 97MHz, 22.5kHz dev. E'=1mV, 1kHz mod. Set volume setting at 1Vrms at speaker output.	Measure at Line-out Flyleads a 1kHz AF signal of 200mVrms.

POWER IGNITION CHECK :

Steps	Permanent (A4)	Ignition (A7)	Action	Observation
1	ON	ON	Turn set ON with power key.	Set is turn on.
2	ON	OFF	Switch OFF ignition	Set switches off. Blinking LED (if any) should blink.
3	ON	ON	Switch ON ignition.	Set will be on.

TUNER CHECK:

IC96 7SV/9SV module is a Non repairable module, complete spare parts as an module is readily available. For general check, please refer to the manual " General Check & Alignment procedures for Car Systems" 4822 725 25456. Use a matching circuit (artificial aerials) with Zi = 75ohm.

CHECK	TUNE IN	OUTPUT
α - 3 dB	FM 97.5MHz, 1mV, Dev=22.5kHz, f mod. = 400Hz FM 97.5MHz, 8uV, Dev=22.5kHz, f mod. = 400Hz	Conn. Block B3, B5 = 0dB (reference level) Conn. Block B3, B5 = -3dB
SDS 10dB Crosstalk	FM 97.5MHz, 1mV, Dev=22.5kHz, f mod. = 1kHz FM 97.5MHz, 150uV, Dev=22.5kHz, f mod. = 1kHz (L)	Conn. Block B3, B5 = 0dB (reference level) Conn. Block B3 = -10dB
Stereo Channel separation	FM 97.5MHz, 1mV, Dev=22.5kHz, f mod. = 1kHz FM 97.5MHz, 1mV, Dev=22.5kHz, f mod. = 1kHz (L)	Conn. Block B3, B5 = 0dB (reference level) Conn. Block B3 ≤ -21dB
26dB SNR	FM 97.5MHz, 4.4uV, Dev=22.5kHz, f mod. = 1kHz FM 97.5MHz, 4.4uV, Dev=22.5kHz, unmodulated	Conn. Block B3, B5 = 0dB (reference level) Conn. Block B3, B5 ≤ -26dB
FM Demodulated level	FM 97.5MHz, 1mV, Dev=22.5kHz, f mod. = 1kHz	Pin 13 of IC96 = 280mV (AC) ± 3dB Pin 7 of IC96 = 215mV (AC) ± 2dB
FM Search Sensitivity	FM 97.5MHz, unmodulated	DX : 10uV < E < 20uV LO : 190uV < E < 290uV
AM Demodulated level	AM 1053kHz, 1mV, m=30%, f mod. = 1kHz	Pin 13 of IC96 = 280mV (AC) ± 2dB
26dB SNR	MW 1053kHz, 22uV, m=30%, f mod. = 1kHz MW 1053kHz, 22uV, unmodulated	Conn. Block B3, B5 = 0dB (reference level) Conn. Block B3, B5 ≤ -26dB
26dB SNR	LW 207kHz, 35uV, m=30%, f mod. = 1kHz LW 207kHz, 35uV, unmodulated	Conn. Block B3, B5 = 0dB (reference level) Conn. Block B3, B5 ≤ -26dB
AM Search Sensitivity	AM 1053kHz, unmodulated	DX : E = 14uV LO : E = 70uV

CLOCK ALIGNMENT :

Signal	Test point	Frequency	Aligned with
CLK	Pin 49 of main uP	682.667Hz	2705
GND	Power supply Gnd		

Service Test Mode :

Press and hold Band key, then turn on the set to enter the service test mode. There are three level of service test mode

First level : LCD display test. All segments of the LCD are lighted up.

Second level : Software release status

"XXXYY r" deontes : RCXXX/YY release 1

e.g. "16900 r" deontes : RC169/00 release 1

Third level : Tuner reception check

"XXXX F M"

XXXX - 4 figures of tuned frequency

F- Field strength

range 0 F hexadecimal

(corresponds to Poor signal strength Good signal strength)

M - Multipath

range 0 ... F hexadecimal

(corresponds to No multipath signal Multipath signal present)

TMP47C820

PINS	1	2	3	4	5	6	7	8	9	10	11	12	13	14	15	16	17
FM(V)	2.95	2.95	2.95	2.95	2.95	2.95	NC	NC	NC	1.05	NC	NC	NC	0.22	0	0.03	0.03
AM(V)	2.95	2.95	2.95	2.95	2.95	2.95	NC	NC	NC	1.05	NC	NC	NC	0.22	0	0.03	0.03
TAPE(V)	2.95	2.95	2.95	2.95	2.95	2.95	NC	NC	NC	1.05	NC	NC	NC	0.22	0	0.03	0.03

PINS	18	19	20	21	22	23	24	25	26	27	28	29	30	31	32	33	34
FM(V)	0.05	NC	0	2.25	2.34	4.75	4.69	NC	4.8	4.8	4.8	0	4.8	2.39	4.8	4.85	0
AM(V)	0.05	NC	0	2.25	2.34	4.75	4.69	NC	4.8	4.8	4.8	0	4.8	2.39	4.8	4.85	0
TAPE(V)	8.78	NC	0	4.21	4.96	4.87	4.69	NC	4.8	0	4.8	0.7	4.8	2.39	4.8	4.96	0

PINS	35	36	37	38	39	40	41	42	43	44	45	46	47	48	49	50	51
FM(V)	4.8	0.04	NC	2.4	4.89	4.9	4.9	4.9	4.9	4.9	4.9	4.9	0	0	0	0	1.82
AM(V)	4.8	0.04	NC	2.4	4.9	4.9	4.9	4.9	4.9	4.9	4.9	4.9	0	0	0	0	1.82
TAPE(V)	4.8	0.02	NC	2.4	4.96	4.96	4.96	4.96	4.96	4.96	4.96	4.96	0	0	0	0	1.82

PINS	52	53	54	55	56	57	58	59	60	61	62	63	64	65	66	67	68
FM(V)	2.32	NC	NC	NC	NC	2.95	2.95	2.95	2.95	2.95	2.95	2.95	2.95	2.95	2.95	2.95	2.95
AM(V)	2.32	NC	NC	NC	NC	2.95	2.95	2.95	2.95	2.95	2.95	2.95	2.95	2.95	2.95	2.95	2.95
TAPE(V)	2.38	NC	NC	NC	NC	2.95	2.95	2.95	2.95	2.95	2.95	2.95	2.95	2.95	2.95	2.95	2.95

PINS	69	70	71	72	73	74	75	76	77	78	79	80
FM(V)	2.95	2.95	2.95	2.95	2.95	2.95	2.95	2.95	2.95	2.95	2.95	2.95
AM(V)	2.95	2.95	2.95	2.95	2.95	2.95	2.95	2.95	2.95	2.95	2.95	2.95
TAPE(V)	2.95	2.95	2.95	2.95	2.95	2.95	2.95	2.95	2.95	2.95	2.95	2.95

UPC1228

PINS	1	2	3	4	5	6	7	8
(V)	1.17	0.81	2.95	8.46	0	2.95	0.81	1.17

TDA8561Q

PINS	1	2	3	4	5	6	7	8	9	10	11	12	13	14	15	16	17
(V)	2.15	0	2.15	7.03	14.4	6.93	0	6.9	NC	6.93	0	6.94	14.3	14	2.15	14.3	2.15

ST24C0286

PINS	1	2	3	4	5	6	7	8
V	4.96	4.9	4.9	0	4.96	4.96	4.96	4.96

HA13119

PINS	1	2	3	4	5	6	7	8	9	10	11	12	13	14	15
V	0.4	0	3.62	0	0	0.4	NC	7	NC	14	NC	0	14.4	14	7

SAA6579T

PINS	1	2	3	4	5	6	7	8	9	10	11	12	13	14	15	16
V	2.5	2.5	2.39	2.37	4.8	0	2.36	2.4	0	0	0	4.8	2.1	2.35	NC	2.4

TRANSISTOR

NO	7903	7904	7905
b	9.15	5.6	5.53
c	13.5	13.5	7.04
e	8.5	4.9	4.8

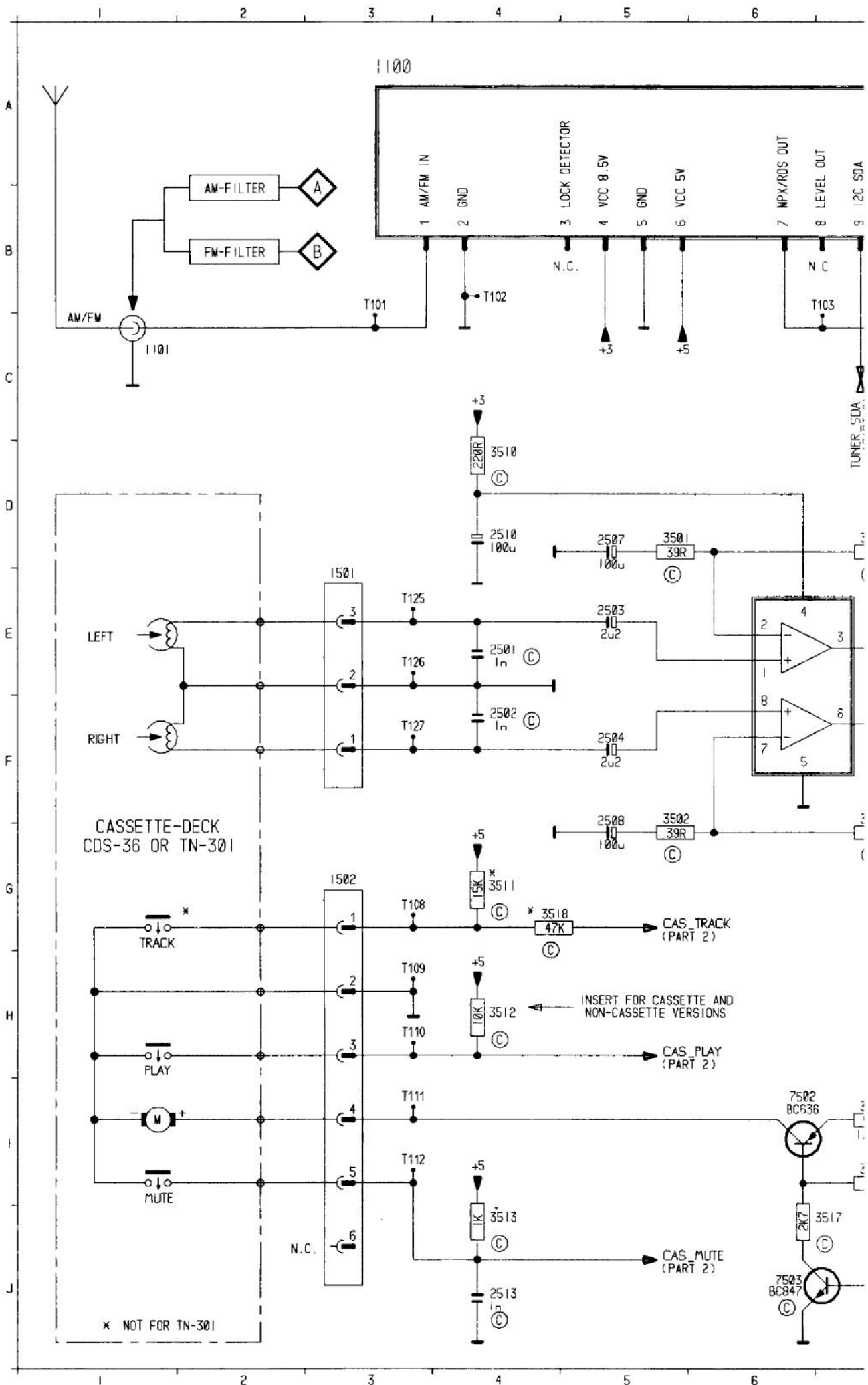

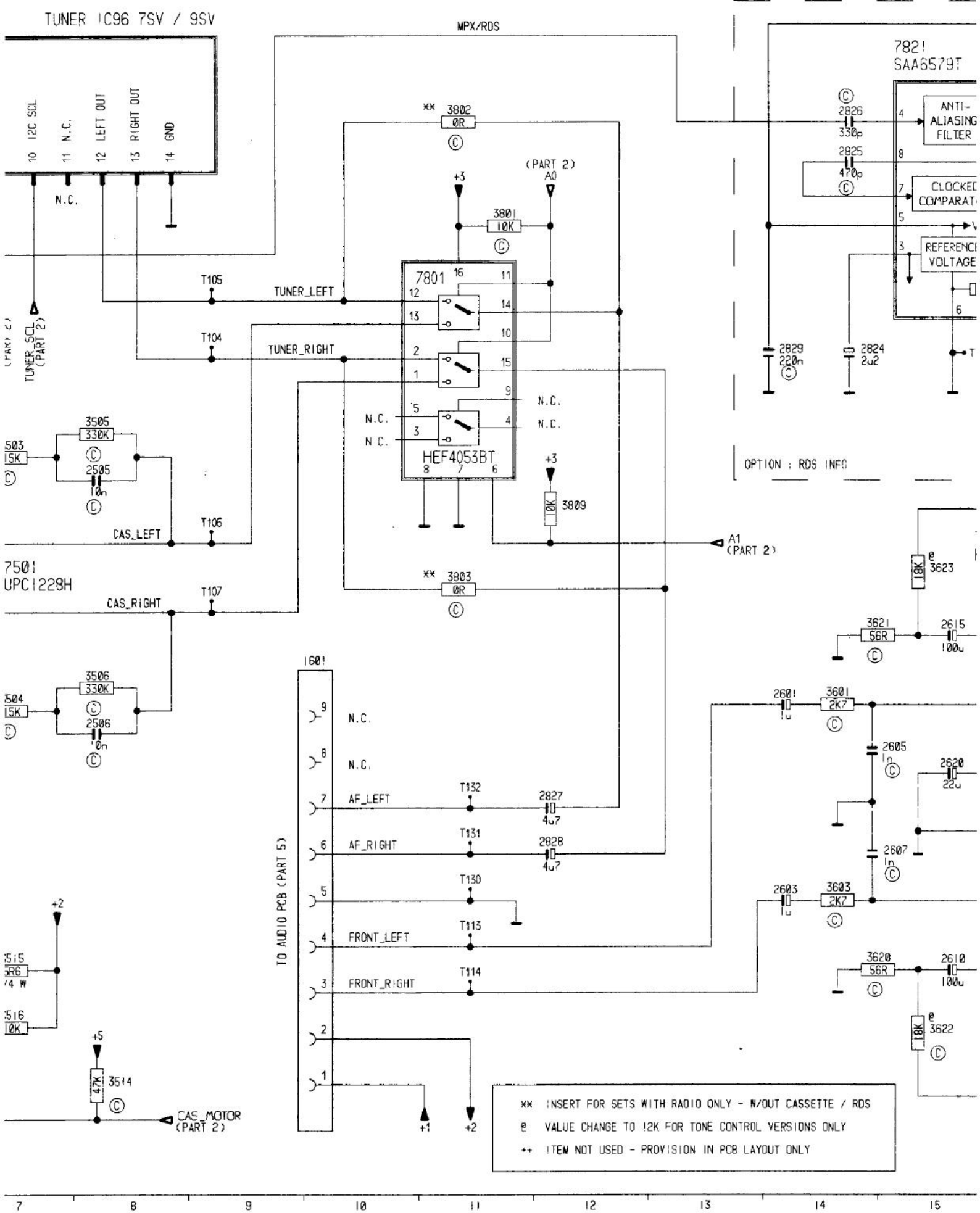

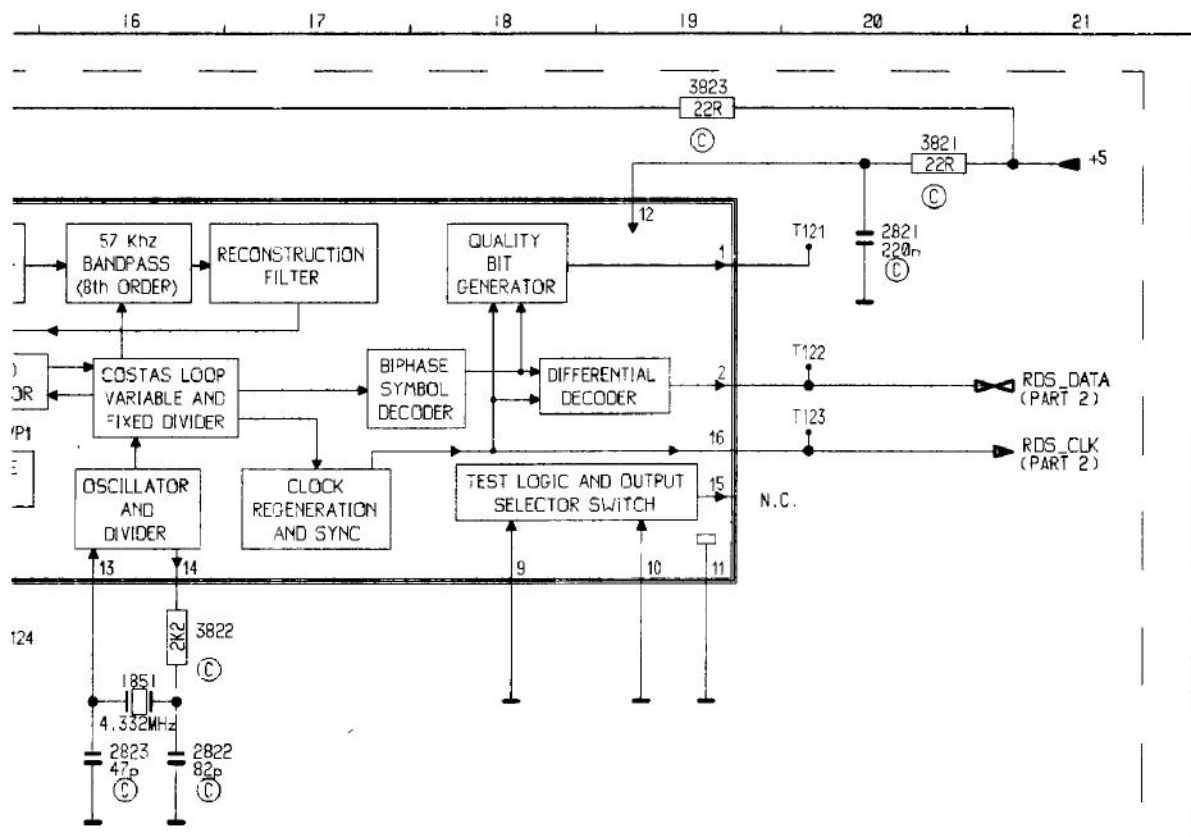

1100	A 3
1101	1
1501	1
1502	1
1601	1
1602	1
1851	L15
1900	F20
2501	4
2502	4
2503	4
2504	4
2505	4
2506	4
2507	4
2508	4
2518	5
2519	5
2515	4
2601	F14
2603	H14
2605	G15
2607	H15
2610	F15
2611	H18
2612	H18
2614	H18
2615	H15
2616	H17
2617	F17
2618	H18
2619	G18
2620	G15
2821	A20
2822	D16
2823	D16
2824	C14
2825	B14
2826	A14
2827	G12
2828	H12
2829	C14
3501	D15
3502	F15
3503	D17
3504	F18
3505	D18
3506	F18
3510	D14
3511	G14
3512	H14
3513	J14
3514	J14
3515	I17
3516	J17
3517	J17
3518	G14
3601	F14
3603	H14
3618	H18
3619	G18
3620	I15
3621	F15
3622	I15
3623	E15
3801	B11
3802	A11
3803	E11
3809	E12
3821	A20
3822	C16
3823	A19
7501	E17
7502	J16
7503	J16
7601	E15
7801	C11
7821	A15

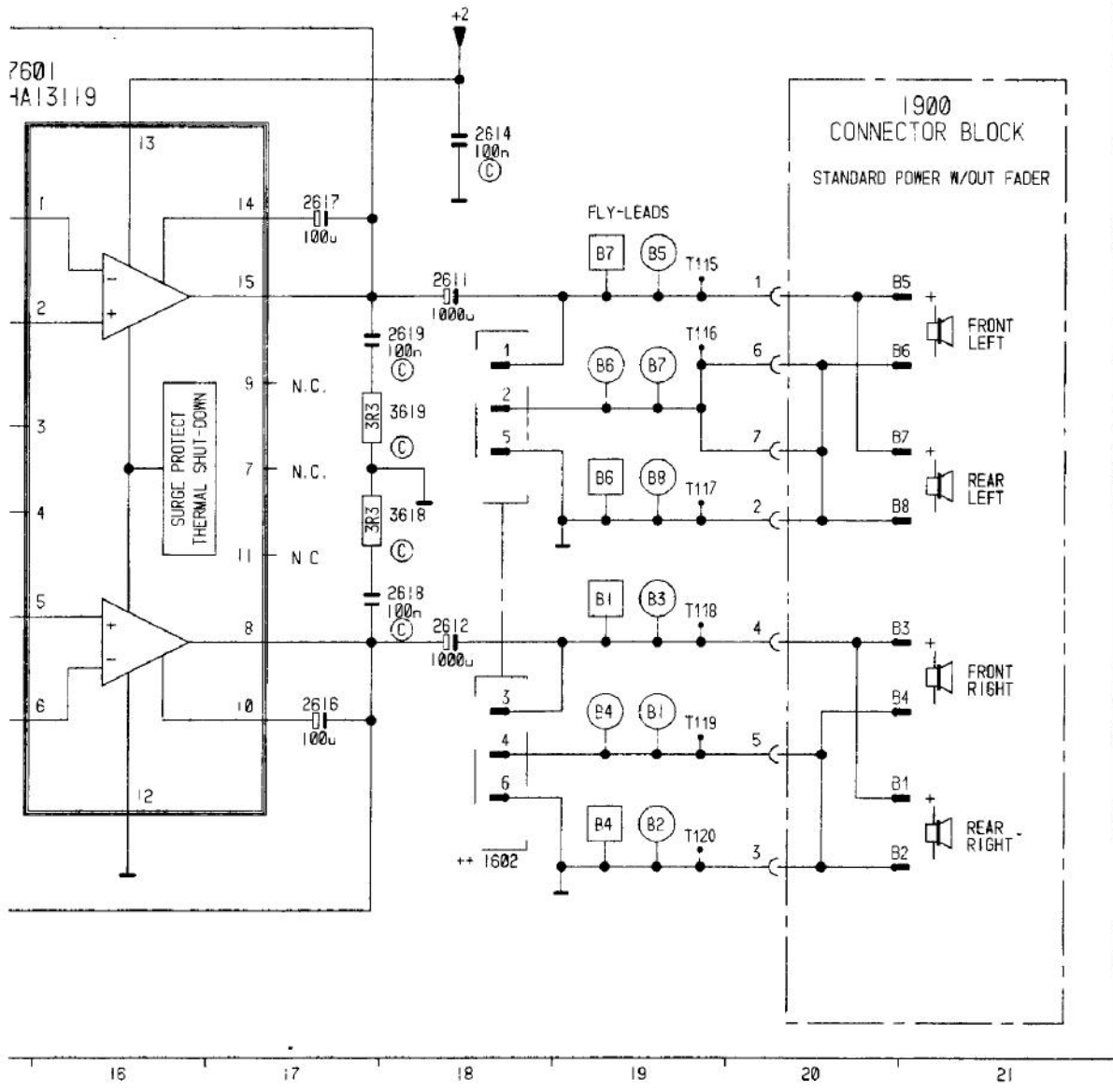

3511	H14
3512	H14
3513	J14
3514	J14
3515	I17
3516	J17
3517	J17
3518	G14
3601	F14
3603	H14
3618	H18
3619	G18
3620	I15
3621	F15
3622	I15
3623	E15
3801	B11
3802	A11
3803	E11
3809	E12
3821	A20
3822	C16
3823	A19
7501	E17
7502	J16
7503	J16
7601	E15
7801	C11
7821	A15

PART 2 : MICRO-CONTROLLER, EEPROM & LCD (MAIN PCB)

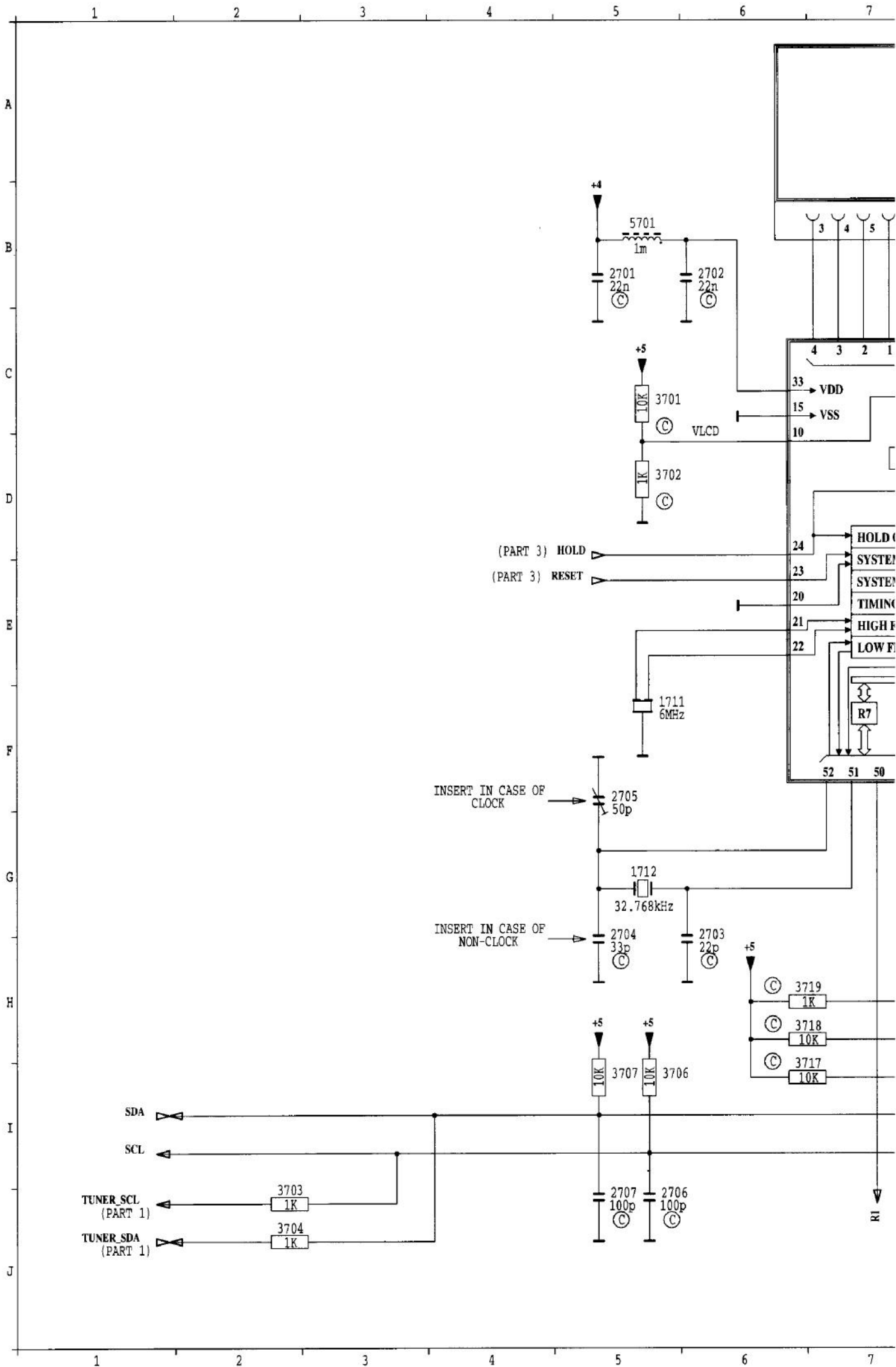

1751
LCD1/2/3/4

7701
TMP47C820

N.C.

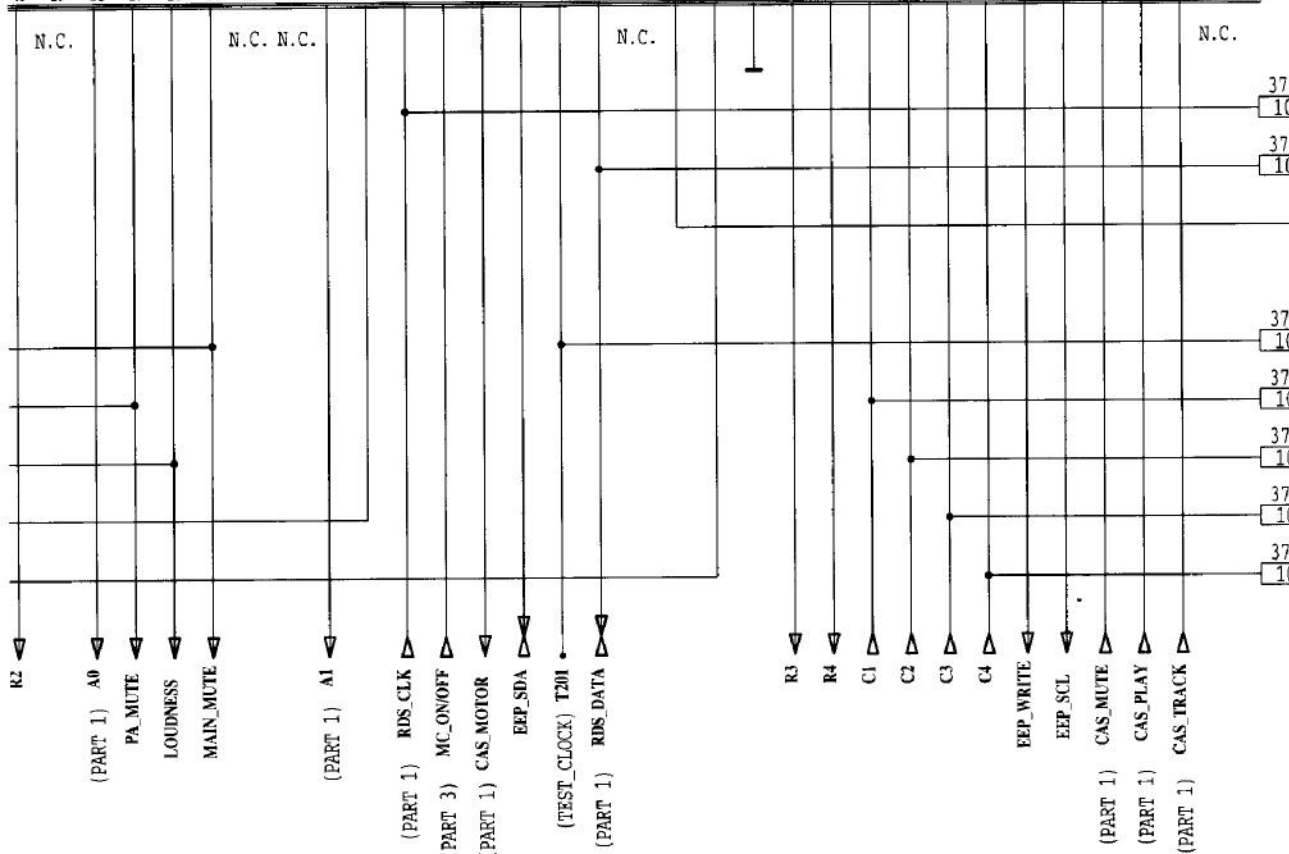
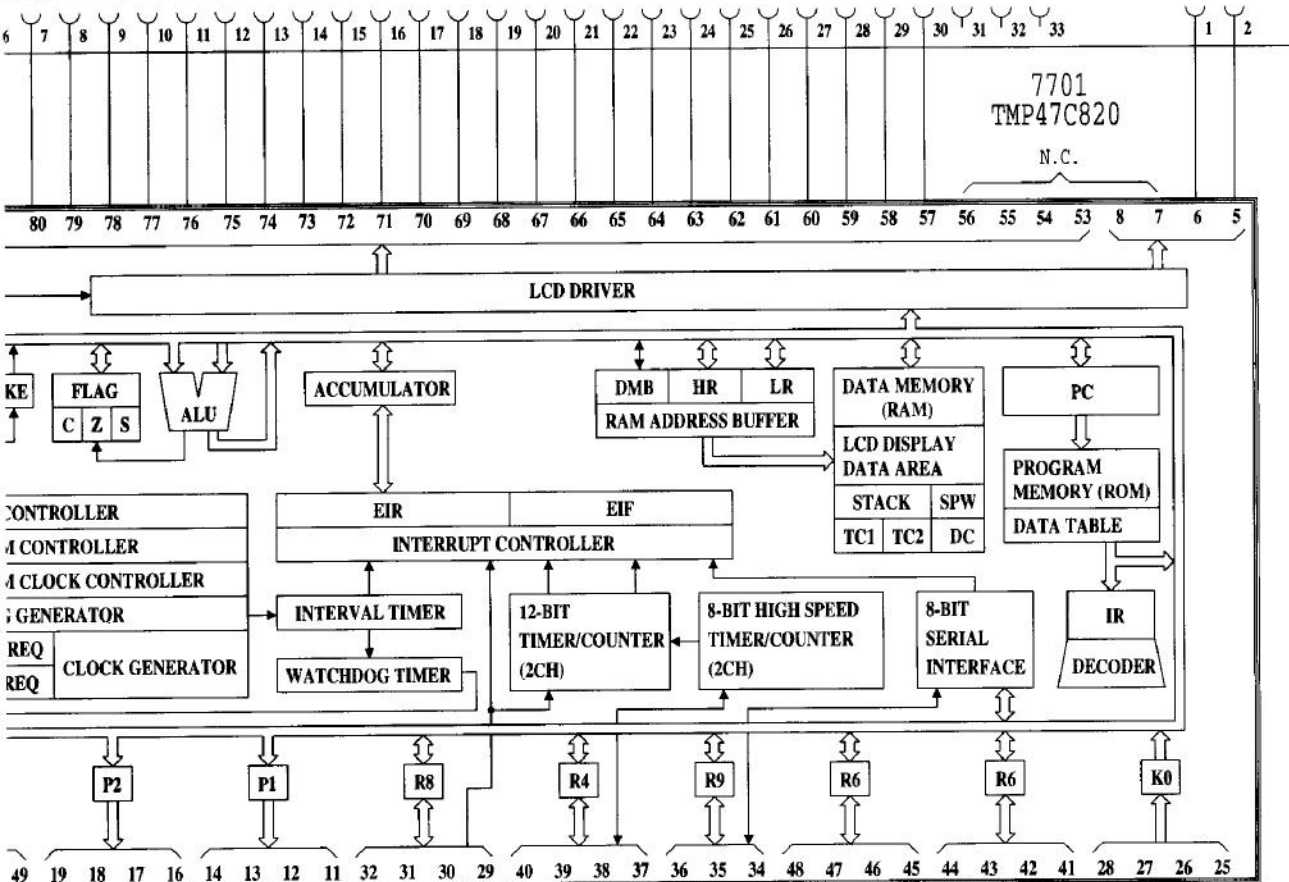

1701 G18
 1702 F21
 1711 F55
 1712 G55
 1751 A12
 2701 B55
 2702 B56
 2703 H56
 2704 H55
 2705 F55
 2706 J55
 2707 J55
 2731 C15
 3701 C55
 3702 D55
 3703 J52
 3704 J52
 3706 J55
 3707 I55
 3708 G15
 3709 G15
 3710 H14
 3711 H14
 3712 I14
 3713 I14
 3714 I14
 3715 G14
 3716 G14
 3717 I 7
 3718 H 7
 3719 H 7
 3731 B16
 3732 C16
 3733 C18
 3734 C19
 3735 C19
 3736 C19
 3737 E19
 3738 C18
 3739 D18
 5701 B 5
 6701 G18
 7701 E12
 7702 G16
 7731 C17

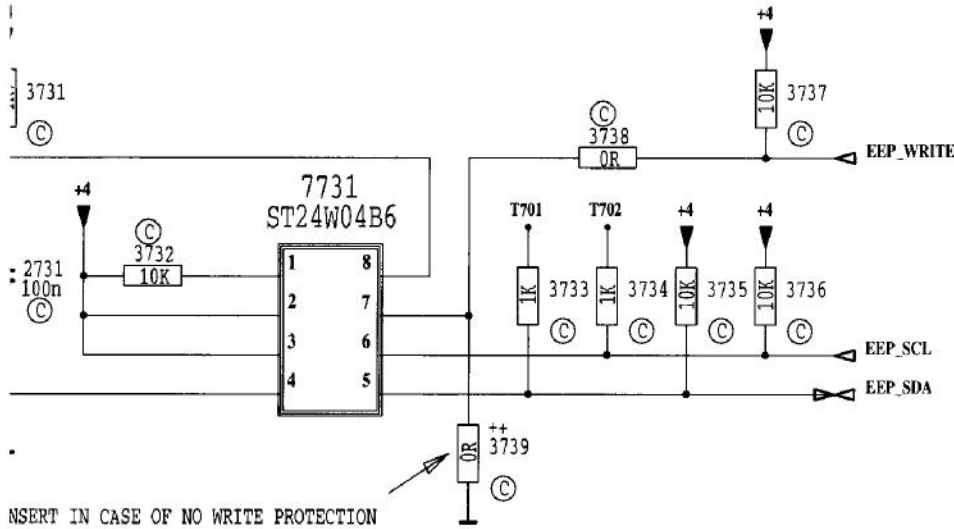

INSERT IN CASE OF NO WRITE PROTECTION

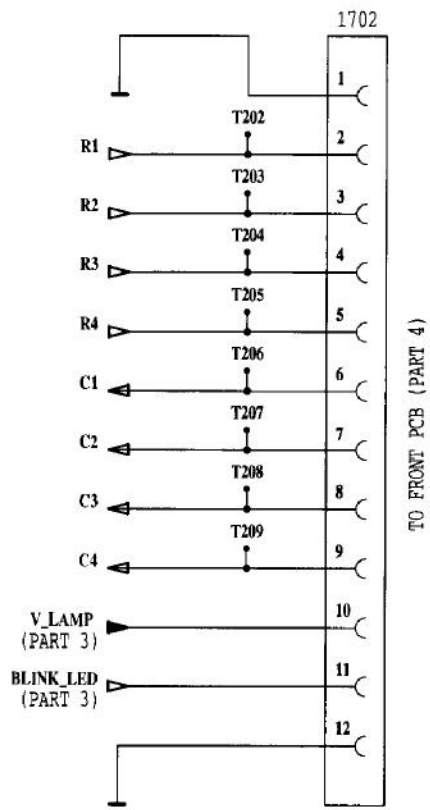
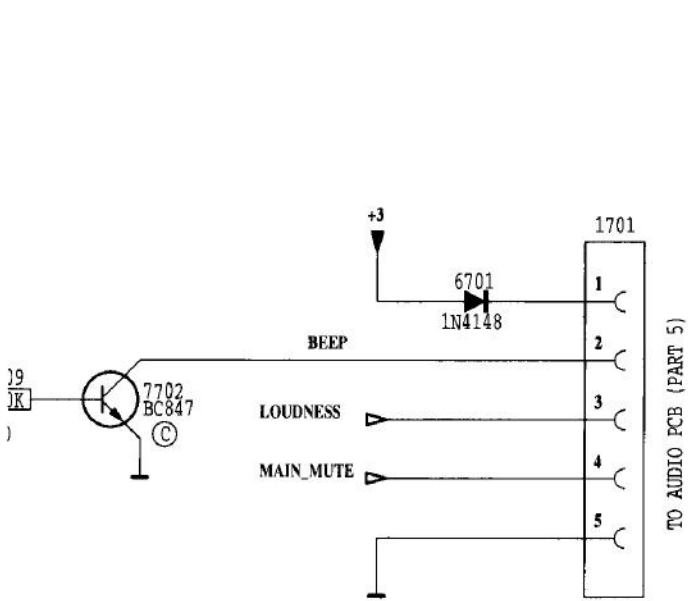

++ ITEM NOT USED - PROVISION IN PCB LAYOUT ONLY

PART 2A : LCD & PIN-OUT TABLE

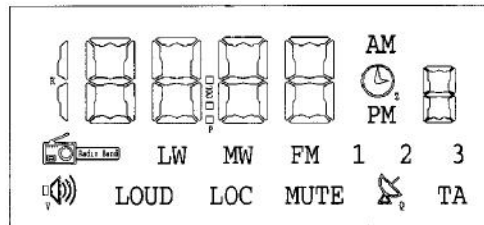

LARGE LCD FOR SETS WITH RADIO ONLY (WITHOUT CASSETTE)

7701 DRIVER PINS	1751 LCD PINS	COM 1	COM 2
6	1	COM 1	
5	2		COM 2
4	3	1e	LW
3	4	1d	1c
2	5	1f	1g
1	6	1a	1b
80	7	2e	MW
79	8	2d	2c
78	9	2f	2g
77	10	2a	2b
76	11	K	P
75	12		
74	13	3e	PM
73	14	3d	3c
72	15	3f	3g
71	16	3a	3b
70	17	4e	1
69	18	4d	4c
68	19	4f	4g
67	20	4a	4b
66	21	2	3
65	22	MUTE	LOC
64	23	5e	LOUD, V
63	24	5d	5c
62	25	5f	5g
61	26	5a	5b
60	27	DOLBY	TA, Q
59	28	AM	COL
58	29	PM	Z
57	30	Radio Band	

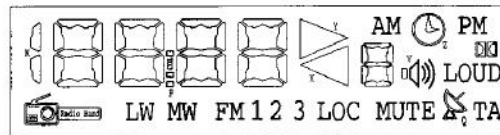

SMALL LCD FOR SETS WITH RADIO AND CASSETTE

7701 DRIVER PINS	1751 LCD PINS	COM 1	COM 2
6	1	COM 1	
5	2		COM 2
4	3	1e	LW
3	4	1d	1c
2	5	1f	1g
1	6	1a	1b
80	7	2e	MW
79	8	2d	2c
78	9	2f	2g
77	10	2a	2b
76	11	K	P
75	12	X	Y
74	13	3e	PM
73	14	3d	3c
72	15	3f	3g
71	16	3a	3b
70	17	4e	1
69	18	4d	4c
68	19	4f	4g
67	20	4a	4b
66	21	2	3
65	22	MUTE	LOC
64	23	5e	LOUD, V
63	24	5d	5c
62	25	5f	5g
61	26	5a	5b
60	27	DOLBY	TA, Q
59	28	AM	COL
58	29	PM	Z
57	30	Radio Band	

EXPLODED VIEW

For sets with Flylead + ISO connector

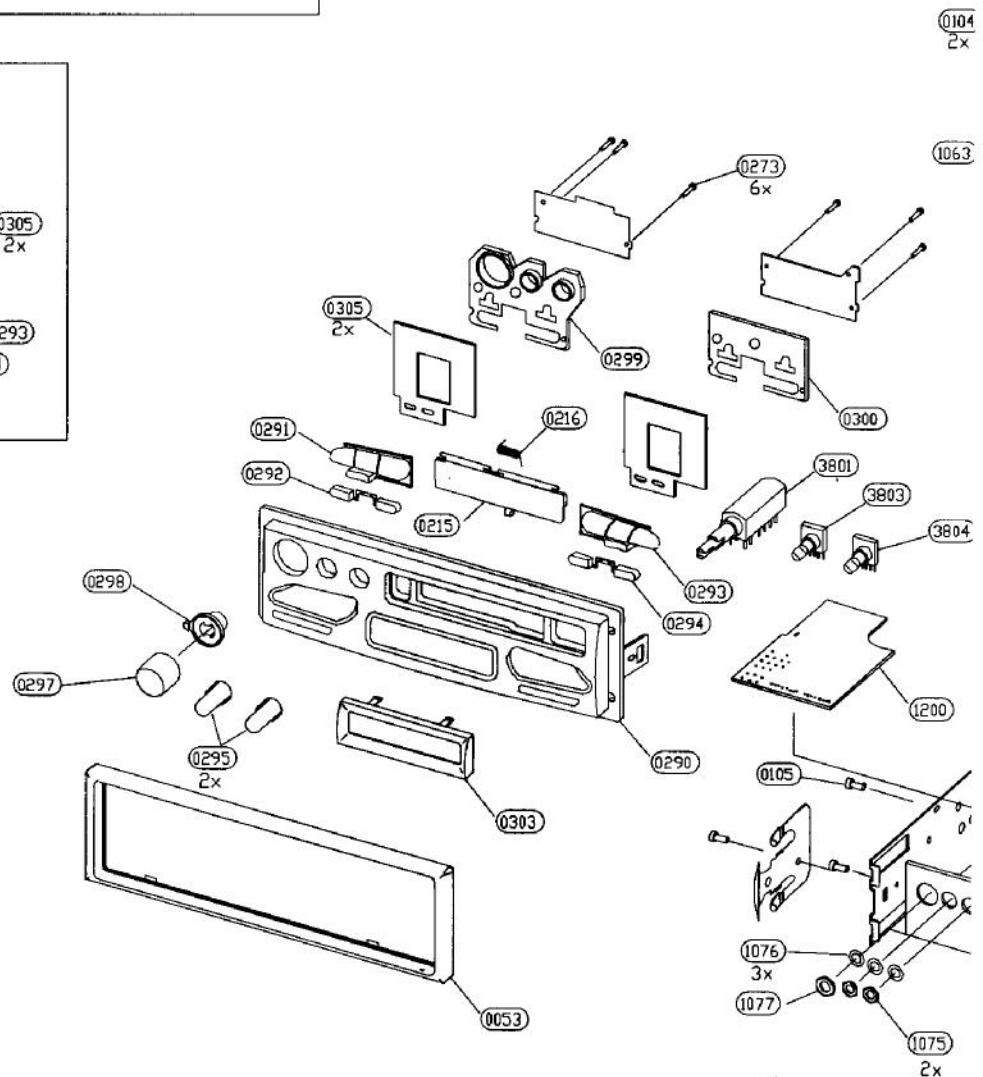
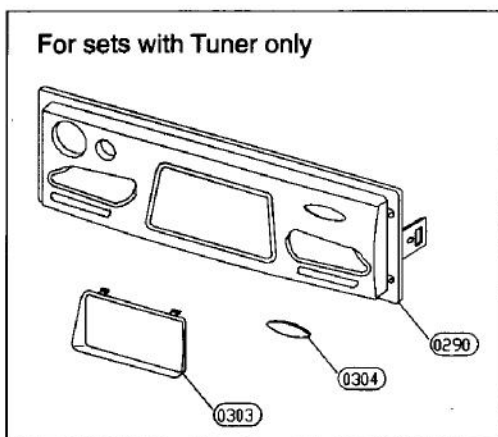
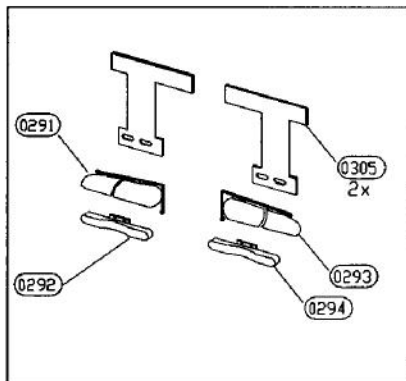
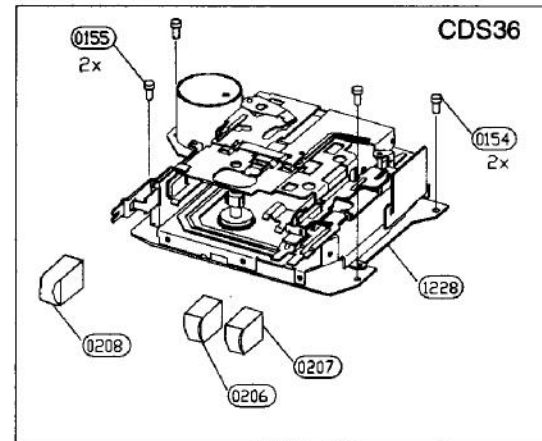
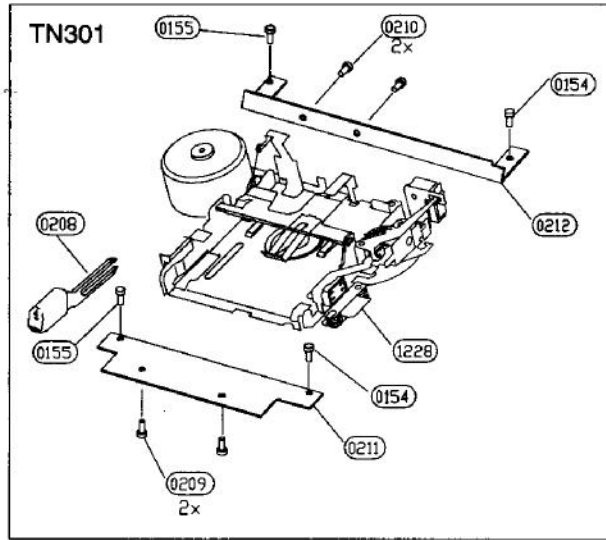
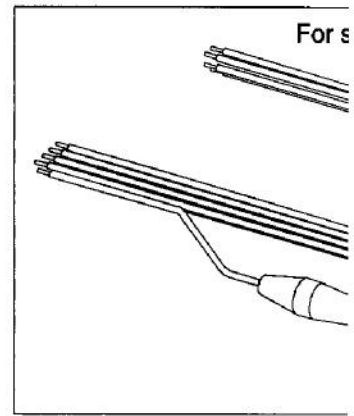
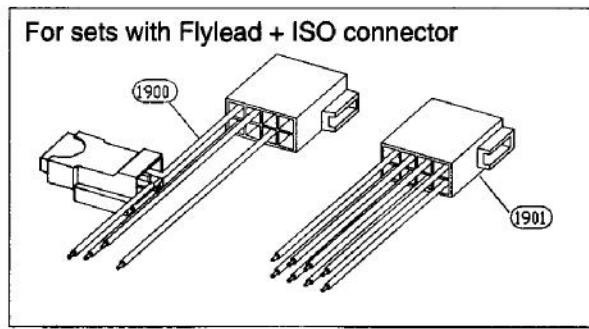

sets with Flylead + 9 pin connector

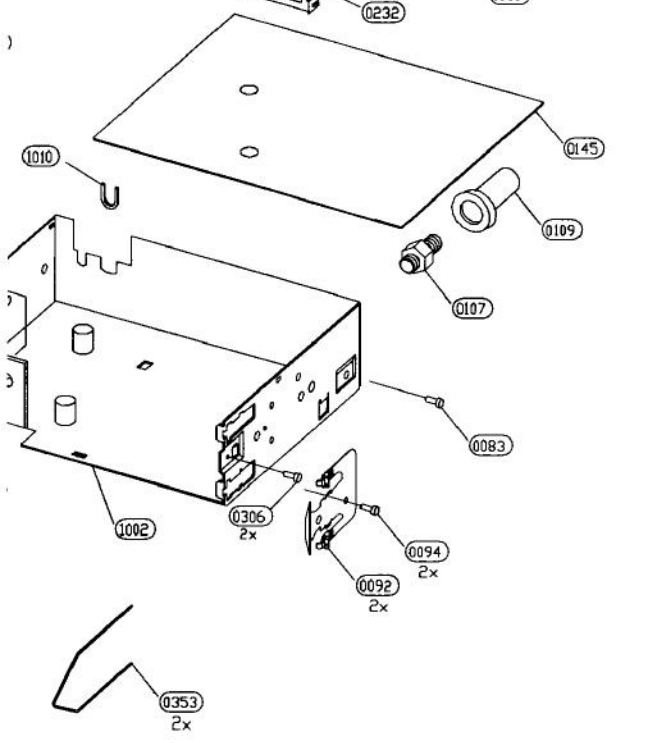
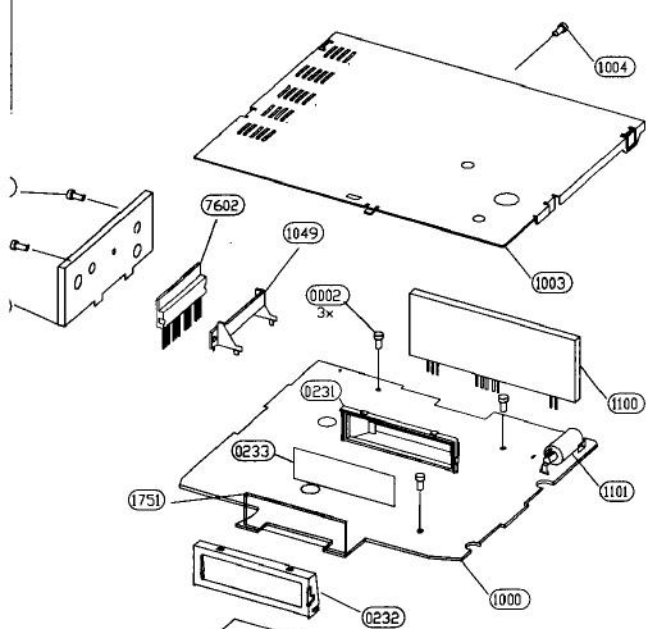
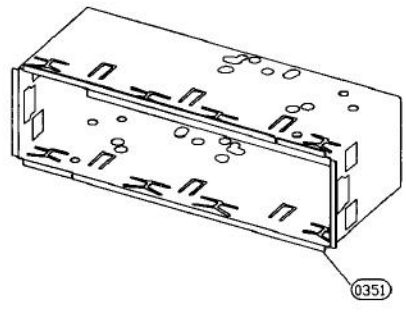
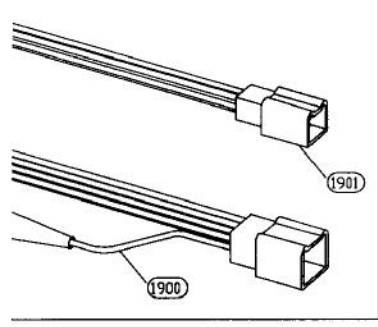

53	4822 466 11561	RIM
206	4822 410 11102	KNOB FF ASSY - RC189
207	4822 410 11103	KNOB REW ASSY - RC189
208	4822 410 11104	KNOB EJ ASSY - RC189
208	4822 410 11092	KNOB EJ ASSY - RC169
215	4822 443 10589	FLAP CASS ASSY - RC189
215	4822 443 10588	FLAP CASS ASSY - RC169
216	4822 492 11445	SPRING FLAP
290	4822 459 04542	PLATE ORN ASSY - RC189
290	4822 459 04541	PLATE ORN ASSY - RC169
291	4822 410 11101	4 KNOB ASSY L
292	4822 410 11085	2-KNOB ASSY L
293	4822 410 11086	4 KNOB ASSY R
294	4822 410 11087	2-KNOB ASSY R
295	4822 410 11091	TONE T/B/TR
297	4822 410 11093	KNOB VOL
353	4822 404 21314	PULL OUT KEY
	4822 736 15405	DFU - MULTI LANGUAGE
	4822 071 25002	BLADE FUSE 5A

MAIN PCB : MISCELLANEOUS

1100	4822 210 10746	TUNER MODULE IC96 7SV
1711	4822 242 81002	RES CER 6MHZ CST6.00MGW
1712	4822 242 70938	RES XTL 32KHZ768
1751	4822 135 00114	LCD1 - NEGATVE
1819	4822 276 13091	SWI TACT 1P 50MA 12V
1820	4822 276 13091	SWI TACT 1P 50MA 12V
1821	4822 276 13091	SWI TACT 1P 50MA 12V
1822	4822 276 13091	SWI TACT 1P 50MA 12V
1823	4822 276 13091	SWI TACT 1P 50MA 12V
1824	4822 276 13091	SWI TACT 1P 50MA 12V
1825	4822 276 13091	SWI TACT 1P 50MA 12V
1826	4822 276 13091	SWI TACT 1P 50MA 12V
1827	4822 276 13091	SWI TACT 1P 50MA 12V
1828	4822 276 13091	SWI TACT 1P 50MA 12V
1829	4822 276 13091	SWI TACT 1P 50MA 12V
1830	4822 276 13091	SWI TACT 1P 50MA 12V
1851	4822 242 72195	QUARZ 4,332 MHZ AT51
1900	4822 265 10936	FLYLEAD + ISO SUPPLY
1901	4822 321 62645	FLYLEAD + ISO SPK CONN.
1911	4822 134 10082	LAMP 12V 50MA CLEAR
1912	4822 134 10082	LAMP 12V 50MA CLEAR
1921	4822 134 10069	LAMP 14V 40MA WITHOUT COLOUR CAP
1922	4822 134 10069	LAMP 14V 40MA WITHOUT COLOUR CAP

MAIN PCB : CAPACITOR

2705	5322 125 50295	CTRM 50V 6P- 50P NP0
------	----------------	----------------------

MAIN PCB : COILS

5701	4822 157 53473	IND FXD LAL04 1000U PM10
5901	4822 156 21434	COIL CHOKE LU019

MAIN PCB : DIODE

6701	4822 130 30621	1N4148
6901	4822 130 81624	1.5KE27
6902	5322 130 30684	1N4002GPE
6903	4822 130 30862	BZX79-C
6904	4822 130 34173	BZX79-C
6905	4822 130 34173	BZX79-C
6908	4822 130 30621	1N4148
6909	5322 130 30684	1N4002GPE
6911	4822 130 30621	1N4148
6912	5322 130 30684	1N4002GPE
6913	5322 130 30684	1N4002GPE
6914	5322 130 30684	1N4002GPE
6950	4822 130 10064	BLINKING LED
6951	4822 130 60379	LED ORANGE - RC189/00
6951	4822 130 83694	LED GREEN - RC189/80
6953	4822 130 60379	LED ORANGE - RC189/00
6953	4822 130 83694	LED GREEN - RC189/80
6955	4822 130 60379	LED ORANGE - RC189/00
6955	4822 130 83694	LED GREEN - RC189/80
6957	4822 130 60379	LED ORANGE - RC189/00
6957	4822 130 83694	LED GREEN - RC189/80

MAIN PCB : TRANSISTORS / IC

7501	4822 209 32969	UPC1228H
7502	4822 130 44283	BC636
7503	4822 130 60511	BC847B
7601	4822 209 32427	HA13119
7701	4822 209 15515	TMP47C820DF/50520
7731	4822 900 11055	ST24W04B4 - RC189/00
7731	4822 900 11074	ST24W04B4 - RC189/80
7702	4822 130 60511	BC847B
7801	5322 209 14481	HEF4053BT

MAIN PCB : TRANSISTORS / IC

7821	4822 209 31981	SAA6579T
7903	4822 130 63539	BD241A
7904	4822 130 40959	BC547B
7905	4822 130 40959	BC547B
7907	4822 130 60511	BC847B
7908	4822 130 60511	BC847B
7911	4822 130 60511	BC847B
7912	4822 130 60511	BC847B
7913	4822 130 60511	BC847B

AUDIO PCB

3851	4822 102 40094	POTMETER VOL W FAD
3852	4822 100 12299	POTMETER 50K TONE
3853	4822 100 12298	POTMETER 50K BALANCE
6854	4822 130 30621	1N4148
7855	4822 130 62513	SS8050C
7856	4822 130 62513	SS8050C

NOTE : "Service code for standard components are not listed here, please refer to Components catalogue from Philips Consumer Service."

MAIN PCB : MISCELLANEOUS

1100	4822 210 10746	TUNER IC96 7SV
1711	4822 242 81002	RES CER 6MHZ0 CST6.00MGW
1712	4822 242 70938	RES XTL 32KHZ768
1751	4822 135 00114	LCD1 - NEGATVE
1819	4822 276 13091	SWI TACT 1P 50MA 12V
1820	4822 276 13091	SWI TACT 1P 50MA 12V
1821	4822 276 13091	SWI TACT 1P 50MA 12V
1822	4822 276 13091	SWI TACT 1P 50MA 12V
1823	4822 276 13091	SWI TACT 1P 50MA 12V
1824	4822 276 13091	SWI TACT 1P 50MA 12V
1825	4822 276 13091	SWI TACT 1P 50MA 12V
1826	4822 276 13091	SWI TACT 1P 50MA 12V
1827	4822 276 13091	SWI TACT 1P 50MA 12V
1828	4822 276 13091	SWI TACT 1P 50MA 12V
1829	4822 276 13091	SWI TACT 1P 50MA 12V
1830	4822 276 13091	SWI TACT 1P 50MA 12V
1851	4822 242 72195	QUARZ 4,332 MHZ AT51
1900	4822 265 10936	FLYLEAD + ISO
1901	4822 321 62645	FLYLEAD + ISO SPK CONN.
1911	4822 134 10082	LAMP 12V 50MA CLEAR
1912	4822 134 10082	LAMP 12V 50MA CLEAR
1921	4822 134 10069	LAMP 14V 40MA WITHOUT COLOUR CAP
1922	4822 134 10069	LAMP 14V 40MA WITHOUT COLOUR CAP

MAIN PCB : CAPACITOR

2705	5322 125 50295	CTRM 50V 6P- 50P NP0
------	----------------	----------------------

MAIN PCB : COILS

5701	4822 157 53473	IND FXD LAL04 1000U PM10
5901	4822 156 21434	COIL CHOKE LU019

MAIN PCB : DIODE

6701	4822 130 30621	1N4148
6901	4822 130 81624	1.5KE27
6902	5322 130 30684	1N4002GPE
6903	4822 130 30862	BZX79-C
6904	4822 130 34173	BZX79-C
6905	4822 130 34173	BZX79-C
6908	4822 130 30621	1N4148
6909	5322 130 30684	1N4002GPE
6911	4822 130 30621	1N4148
6912	5322 130 30684	1N4002GPE
6913	5322 130 30684	1N4002GPE
6914	5322 130 30684	1N4002GPE
6950	4822 130 10064	BLINKING LED
6951	4822 130 60379	LED ORANGE - RC169/00
6951	4822 130 83694	LED GREEN - RC169/80
6953	4822 130 60379	LED ORANGE - RC169/00
6953	4822 130 83694	LED GREEN - RC169/80
6955	4822 130 60379	LED ORANGE - RC169/00
6955	4822 130 83694	LED GREEN - RC169/80
6957	4822 130 60379	LED ORANGE - RC169/00
6957	4822 130 83694	LED GREEN - RC169/80

MAIN PCB : TRANSISTORS / IC

7501	4822 209 32969	UPC1228H
7502	4822 130 44283	BC636
7503	4822 130 60511	BC847B
7601	4822 209 32427	HA13119
7701	4822 209 15515	TMP47C820DF/50520
7702	4822 130 60511	BC847B
7703	4822 900 11056	ST24W04B6 - RC169/00
7703	4822 900 11057	ST24W04B6 - RC169/80
7801	5322 209 14481	HEF4053BT

MAIN PCB : TRANSISTORS / IC

7821	4822 209 31981	SAA6579T
7903	4822 130 63539	BD241A
7904	4822 130 40959	BC547B
7905	4822 130 40959	BC547B
7907	4822 130 60511	BC847B
7908	4822 130 60511	BC847B
7911	4822 130 60511	BC847B
7912	4822 130 60511	BC847B
7913	4822 130 60511	BC847B

AUDIO PCB

3851	4822 102 40094	POTMETER VOL W FAD
3852	4822 100 12299	POTMETER 50K TONE
3853	4822 100 12298	POTMETER 50K BALANCE
6854	4822 130 30621	1N4148
7855	4822 130 62513	SS8050C
7856	4822 130 62513	SS8050C

NOTE : "Service code for standard components are not listed here, please refer to Components catalogue from Philips Consumer Service."

MEMO