

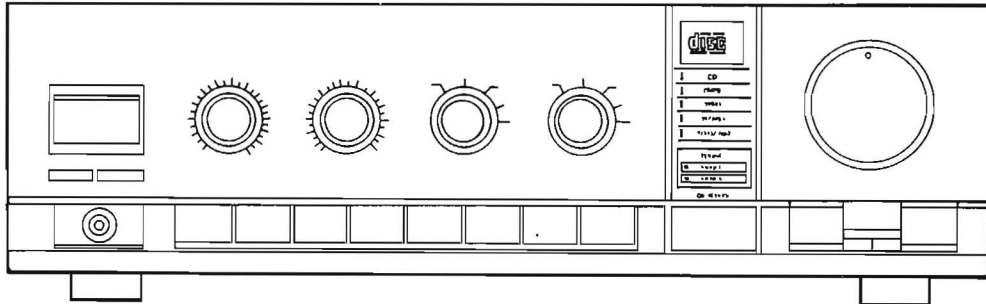

CONSUMER ELECTRONICS

PHILIPS



FA 960

Amplifier

WARNING

TO REDUCE THE RISK OF FIRE OR ELECTRIC SHOCK, DO NOT EXPOSE THIS APPLIANCE TO RAIN OR MOISTURE.

The Model and Serial Number of this unit will be found on the type plate on the back of the set. Please record the Model and Serial Number in the space provided below.

MODEL

NUMBER: _____

SERIAL

NUMBER: _____

This set complies with the FCC-rules, Part 15.

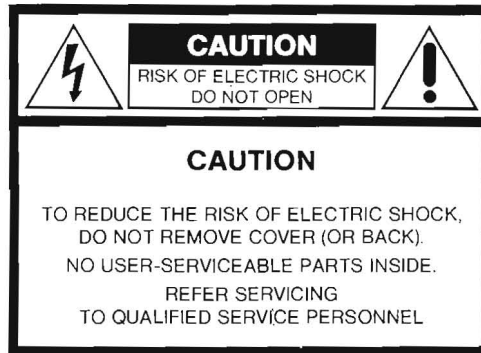

This symbol is intended to alert the user of the presence of uninsulated 'dangerous voltage' within the product's enclosure, that may be of sufficient magnitude to constitute a risk of electric shock to persons.



This symbol is intended to alert the user of the presence of important operating and maintenance (servicing) instructions in the literature accompanying the appliance.

SAFETY INSTRUCTIONS

Read before operating equipment

This product was designed and manufactured to meet strict quality and safety standards. There are, however, some installation and operation precautions which you should be particularly aware of.

1. Read Instructions - All the safety and operating instructions should be read before the appliance is operated.
2. Retain Instructions - The safety and operating instructions should be retained for future reference.
3. Heed Warnings - All warnings on the appliance and in the operating instructions should be adhered to.
4. Follow Instructions - All operating and use instructions should be followed.
5. Water and Moisture - The appliance should not be used near water - for example, near a bathtub, washbowl, kitchen sink, laundry tub, in a wet basement or near a swimming pool, etc.
6. Carts and Stands - The appliance should be used only with a cart or stand that is recommended by the manufacturer.
7. Wall or Ceiling Mounting - The appliance should be mounted to a wall or ceiling only as recommended by the manufacturer.
8. Ventilation - The appliance should be situated so that its location or position does not interfere with its proper ventilation. For example, the appliance should not be situated on a bed, sofa, rug, or similar surface that may block the ventilation openings; or, placed in a built-in installation, such as a bookcase or cabinet that may impede the flow of air through the ventilation openings.
9. Heat - The appliance should be situated away from heat sources such as radiators, heat registers, stoves, or other appliances (including amplifiers) that produce heat.
10. Power Sources - The appliance should be connected to a power supply only of the type described in the operating instructions or as marked on the appliance.
11. Grounding or Polarization - The precautions that should be taken so that the grounding or polarization means of an appliance is not defeated.
12. Power-Cord Protection - Power supply cords should be routed so that they are not likely to be walked on or pinched by items placed upon or against them, paying particular attention to cords and plugs, convenience receptacles, and the point where they exit from the appliance.
13. Cleaning - The appliance should be cleaned only as recommended by the manufacturer.
14. Power Lines - An outdoor antenna should be located away from power lines.
15. Outdoor Antenna Grounding - If an outside antenna is connected to the receiver, be sure the antenna system is grounded so as to provide some protection against voltage surges and built up static charges.
Section 810. of the National Electric Code, ANSI/NFPA No. 70-1984, provides information with respect to proper grounding of the mast and supporting structure, grounding of the lead-in wire to an antenna discharge unit, size of grounding connectors, location of antenna-discharge unit, connection to grounding electrodes, and requirements for the grounding electrode. See Fig. A.
16. Nonuse Periods - The power cord of the appliance should be unplugged from the outlet when left unused for a long period of time.
17. Object and Liquid Entry - Care should be taken so that objects do not fall and liquids are not spilled into the enclosure through openings.
18. Damage Requiring Service - The appliance should be serviced by qualified service personnel when:
 - A. The power-supply cord or the plug has been damaged; or
 - B. Objects have fallen, or liquid has spilled into the appliance; or
 - C. The appliance has been exposed to rain; or
 - D. The appliance does not appear to operate normally or exhibits a marked change in performance; or
 - E. The appliance has been dropped, or the enclosure damaged.
19. Servicing - The user should not attempt to service the appliance beyond that described in the operating instructions. All other servicing should be referred to qualified service personnel.

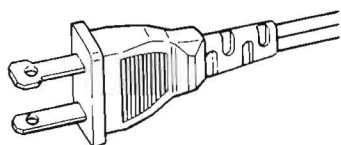

AC POLARIZED PLUG

FIG. A

**EXAMPLE OF ANTENNA GROUNDING
ACCORDING TO THE NATIONAL ELECTRIC CODE INSTRUCTIONS
CONTAINED IN ARTICLE 810 - "RADIO AND TELEVISION EQUIPMENT"**

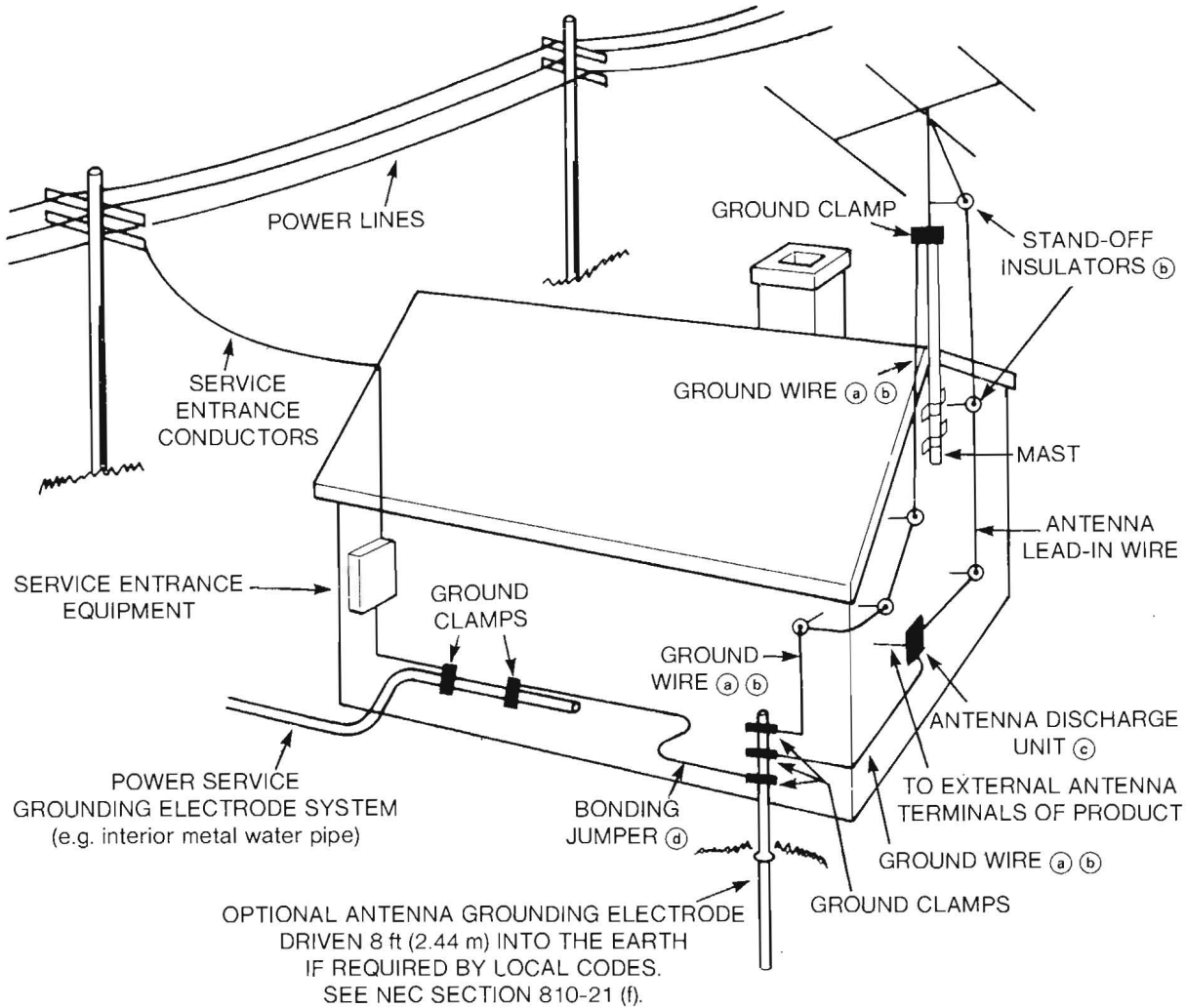

(a) Use No. 10 AWG (5.3 mm²) copper, No. 8 AWG (8.4 mm²) aluminum, No. 17 AWG (1.0 mm²) copper-clad steel or bronze wire, or larger, as a ground wire.

(b) Secure the antenna lead-in and ground wires to the house with stand-off insulators spaced from 4-6 feet (1.22-1.83 m) apart.

(c) Mount the antenna discharge unit as close as possible to where the lead-in wire enters the house.

(d) Use jumper wire not smaller than No. 6 AWG (13.3 mm²) copper, or the equivalent, when a separate antenna-grounding electrode is used. See NEC Section 810-21 (J).

NOTE TO THE CATV SYSTEM INSTALLER:

This reminder is provided to call the CATV system installer's attention to Article 820-22 of the NEC that provides guidelines for proper grounding and, in particular, specifies that the cable ground shall be connected to the grounding system of the building, as close to the point of cable entry as practical.

Operating Instructions

INTRODUCTION

This amplifier is unique in the field of audio engineering. By making use of the most recent techniques, this amplifier offers you years of listening pleasure of unequaled quality. We advise you to read these operating instructions carefully; you will then quickly become familiar with the facilities which this amplifier offers.

INSTALLATION

Remember the following important points when installing the amplifier:

- Do not expose the amplifier to rain or moisture, as this may cause damage to the amplifier.
- All amplifiers produce some heat during operation and this heat must be allowed to dissipate freely. Do not close any ventilation openings and insure that there is adequate ventilation space behind, beside and above the amplifier.
- Prevent extra heat from reaching the unit. Never put the amplifier in the full glare of the sun or near to a heat source.

CONNECTIONS

The following points are important when connecting the equipment to the amplifier:

- Check that the amplifier is not switched on.
 - Make each connection individually.
 - Check that each connection has been made correctly and press the plugs firmly into the jacks.
 - Always connect plugs or jacks marked 'L' or 'LEFT' to similarly marked jacks on the amplifier.
- Do the same with jacks and plugs marked 'R' or 'RIGHT'.
- Always connect the 'OUT' outputs of a recorder to the 'IN' jacks of the amplifier and the 'IN' inputs of the recorder to the 'OUT' jacks of the amplifier.

Figure 2

- (A) 'PHONO' jacks
For connecting a record player with an 'MM' (Moving Magnet) or an 'MC' (Moving Coil) cartridge.
Note: These jacks are gold-plated so that the contact resistance between these jacks and the connecting cords of the player is kept as small as possible. In order to maintain the high-grade quality of this connection, we recommend that connecting cords are used which also have gold-plated plugs.
- (B) 'CD' jacks
For connecting a Compact Disc player.
Note: See note under (A).
- (C) 'TUNER' jacks
For connecting a tuner.
- (D) 'TV/AUX 1' jacks
For connecting the audio output of a TV set or other equipment with an output level that is suitable for this input.
- (E) 'VIDEO/AUX 2' jacks
For connecting the audio output of a video unit or other equipment with an output level that is suitable for this input.
- (F) connection screw for earth wire of record player 'GND'
For connecting the earth wire of a record player. Prevents hum.
- (G) 'TAPE OUT 2' jacks
For connecting the line inputs (LINE IN) of a recorder.
- (H) 'TAPE IN 2' jacks
For connecting the line outputs (LINE OUT) of a recorder.
- (I) 'TAPE OUT 1' jacks
For connecting the line inputs (LINE IN) of a recorder.
- (J) 'TAPE IN 1' jacks
For connecting the line outputs (LINE OUT) of a recorder.
- (K) 'SPEAKERS' connections
For connecting one or two pairs of speakers. See Figs. 3 and 4.
See also 'GENERAL INFORMATION' section.
- (L) fuse compartment
Contains a fuse which continuously protects the amplifier against overload.
Important: A faulty fuse should be replaced by the same type of fuse to prevent a possible malfunction.
- (M) power cord
- (N) power output jacks 'AC OUTLETS'
Switched and unswitched power voltage outputs for the connection of the power plugs of various sets such as tuner, cassette recorder, record player etc.

CONTROLS AND THEIR FUNCTIONS

Figure 1

- ① 'POWER' switch
If the 'POWER' switch is pressed, it takes seven seconds before the amplifier is completely switched on. This switching on may be heard by the snapping-in of the speaker relays.
- ② 'BASS/TREBLE' tone controls
Bass and treble can be adjusted to your own preference using these controls. The neutral position is '0'.
- ③ 'REC OUT' recorder output switch
For transmitting the signal from the sound source to be recorded to the jacks ⑥ 'TAPE OUT 2' or ① 'TAPE OUT 1'. If no recording is made, this switch should preferably be set to the 'Source' position.
Note: For further details on the use of this switch, see section 'Use with a recorder' under 'OPERATION'.
- ④ 'SELECTOR' sound source selector switch
For playback from a Compact Disc player, record player, tuner, television and video equipment, which are connected to the corresponding jacks.
- ⑤ function display with indicators for: 'CD', 'PHONO', 'TUNER', 'TV/AUX 1', 'VIDEO/AUX 2', 'TAPE 1' and 'TAPE 2'.
These indicators light up according to the sound source selected.
- ⑥ 'CD DIRECT' indicator
This indicator lights up if selector switch ⑱ 'CD DIRECT' is pressed in.
- ⑦ 'VOLUME' control
For adjusting the volume level to your preference; clockwise increases the volume, counter-clockwise decreases.
- ⑧ 'PHONES' jack for stereo headphones
For connecting stereo headphones with an impedance of 8-1000 ohms. By unlocking the switches ⑨ 'SPEAKERS', it is possible to listen separately via the headphones.
- ⑨ 'SPEAKERS' switches A and B
For switching the speakers connected to the corresponding speaker connections ⑫ on and off.
See also 'GENERAL INFORMATION' section for this.
- ⑩ 'LOUDNESS' correction switch
Switch for additionally amplifying the treble and bass at a low volume.
- ⑪ 'TONE DEFEAT' tone control switch
For switching the tone controls ② 'BASS/TREBLE' on and off. Switch not pressed in, then the sound reproduction can be modified with tone controls ②.
Switch pressed in, then the tone control is switched off. This is comparable with the tone controls ② in the neutral position '0'.
- ⑫ 'MONO' switch
In the 'MONO' position (pressed in) the channel separation between left and right is canceled. The same (mixed) signal is reproduced via both channels.
Select this position if stereo noise occurs during the reception of weak FM stereo broadcasts or when reproducing a mono (= single channel) sound source.
In all other cases select the 'STEREO' position (not pressed in).
- ⑬ 'TAPE MONITOR 1' selector switch
For playback from a recorder connected to the jacks ① and ②.
Important: This switch overrides selector switches ④ and ⑭.
- ⑭ 'TAPE MONITOR 2' selector switch
For playback from a recorder connected to jacks ③ and ④.
Important: This switch overrides the sound source selector switch ④.
- ⑮ 'TAPE COPY 1 → 2' dubbing button
For dubbing sound recording tapes from recorder tape 1 to recorder tape 2.
- ⑯ 'TAPE COPY 2 → 1' dubbing button
For dubbing sound recording tapes from recorder tape 2 to recorder tape 1.
- ⑰ selector switch for 'MM' or 'MC' record player cartridge
Depending on the cartridge used, this switch must be in the 'MM' (Moving Magnet) or 'MC' (Moving Coil) position.
See the record player manual for this.
Button ⑰ not pressed in: 'MM' position.
Button ⑰ pressed in: 'MC' position.
- ⑱ Compact Disc direct switch 'CD DIRECT'
For direct playback from a Compact Disc player.
Note: For further details on the use of this switch, see section 'Use with the CD DIRECT switch' under 'OPERATION'.
- ⑲ 'BALANCE' control
For the balance adjustment of left and right stereo channel.

OPERATION

Use with the sound source selector switch

1. Insure that the volume control (7) 'VOLUME' is not set at maximum.
Set this preferably to a low position in order to prevent damage to your speakers.
2. Switch the amplifier on with switch (1) 'POWER'.
The border lighting around the volume control (7) and above the 'POWER' switch (1) lights up.
3. Switch the speakers on with switch(es) (9) 'SPEAKERS'.
Button 'A' pressed in: for speakers connected to the speaker connections (K) 'system A', see Figure 3.
Button 'B' pressed in: for speakers connected to the speaker connections (K) 'system B', see Figure 4.
4. Switch the required sound source on and set it for playback.
5. Set the 'SELECTOR' switch (4) on the amplifier to the position corresponding to the sound source.
The corresponding indicator now lights up on the 'function display' (5).
Important: Selector switches (13) and (14) should only be pressed in if you want to make a recording. In all other cases the sound is interrupted if the selector switches (13) or (14) are pressed in.
6. Slowly adjust the volume with control (7) 'VOLUME'.

You cannot hear anything and no indicator lights up?

- The amplifier is not switched on.
- The amplifier is not connected to the power.
- The fuse (L) is faulty.
- The jack is not live.

You cannot hear anything but an indicator lights up?

- Is 'SELECTOR' (4) in the correct position?
- Is the selected sound source functioning properly?
- Are the speakers properly switched on?
- Is the volume control open enough?
Do not keep it in the MAX position!
- Is button (13) 'TAPE MONITOR 1' or (14) 'TAPE MONITOR 2' pressed in?
- Are the speakers connected properly?
Before you check this, insure that the amplifier is switched off.

7. Adjust the stereo balance with control (19) 'BALANCE'.
8. Adjust the bass and treble with the control (2) 'BASS/TREBLE'.
9. If required, press the mono switch (12) 'MONO'.
10. If required, press the correction switch (10) 'LOUDNESS' with a low volume position.
11. If required, press the tone control switch (11) 'TONE DEFEAT'.

Does the sound come from one side?

- Is the balance control set correctly?
- Check the connection with the faulty speaker.
- Check the connection between sound source and amplifier.
- If using headphones, check that the plug is properly inserted in the jack.

Does the amplifier hum, buzz or howl during record playback?

- Check the grounding of the record player.
- Are the connection plugs pushed far enough into the jacks?
- Keep the connection cord to the record player as far away as possible from power cords (hum) or TV circuits (buzz).
- The amplifier may howl as a result of acoustical feedback from the speakers to the record player unit. This occurs mainly at higher volumes. In this case change the positioning of the speaker.

Use with the CD DIRECT switch

For direct playback from a Compact Disc player.
If you use this switch, the signal from the connected CD player is led directly via the volume control and the flat internal 'Tone Defeat' amplifier to the output amplifier and reproduced amplified. The advantage of this is that the sound signal passes through as few circuits as possible and thus gives high-fidelity reproduction.

Playback

1. Switch the amplifier on with (1) 'POWER'.
2. Switch the speakers on with (9) 'SPEAKERS'.
3. Switch the CD player on and set it for playback.
4. Press the 'CD DIRECT' switch (18) on the amplifier.

If the 'CD DIRECT' switch (18) is pressed in:

- the 'CD DIRECT' indicator (6) lights up.
- the 'SELECTOR' switch (4) is overridden.
- the tone controls (2) 'BASS/TREBLE' are switched off.
- the 'MONO' switch (12) is switched off.
- the selector switches (13) 'TAPE MONITOR 1' and (14) 'TAPE MONITOR 2' are overridden.
- the signal inputs and outputs, with the exception of the CD input of the amplifier, are disconnected, so that the high quality of the CD signal is not affected.
Consequently no sound recording can be made with recorder 1 and/or recorder 2.

Note: After playback is completed, the 'CD DIRECT' switch (18) should be released, by pressing the switch once more. Indicator (6) goes off.

5. Slowly adjust the volume with control (7) 'VOLUME'.
6. Adjust the stereo balance with control (19) 'BALANCE'.
7. If required, press correction switch (10) 'LOUDNESS' at a low volume setting.

Use with a recorder

Playback

Playback from a recorder connected to the jacks (G) and (H) or (I) and (J) occurs in the same way as from any other sound source, as indicated under 4., 5. and 6. in the section 'Use with the sound source selector switch'.

Now however press selector switch (13) 'TAPE MONITOR 1' or (14) 'TAPE MONITOR 2'. Indicator 'TAPE 1' or 'TAPE 2' now lights up on function display (5).

Recording

It is possible to make a recording in two ways:

- With the recorder output switch (3) 'REC OUT' in the 'source' position. The signal at the jacks (G) and (I) is the same as that which can be heard through the speakers and/or headphones. At the same time set a recorder connected to jacks (G) and (H) or (I) and (G) ready for recording.
- With the recorder output switch (3) 'REC OUT' in the position 'CD', 'PHONO', 'TUNER', 'TV/AUX 1' or 'VIDEO/AUX 2'. The signal at the jacks (G) and (I) then corresponds to the selected 'REC OUT' position (provided this sound source is set for operation).

There is now the facility to make a recording from the selected sound source with (3) 'REC OUT', while you are listening to another sound source selected with (4) 'SELECTOR'. At the same time set a recorder connected to jacks (G) and (H) or (I) and (J) ready for recording.

Note: Adjustment of the tone, volume and balance control and mono/stereo switch will not affect the recording.

It is not possible to make a recording if the 'CD DIRECT' switch (18) is pressed in.

Listening while recording with a recorder

It is possible to listen while recording in two ways:

- With selector switch (13) 'TAPE MONITOR 1' or (14) 'TAPE MONITOR 2' not pressed in.

You hear the signal as it goes directly from the sound source to the amplifier and it is reproduced amplified (method 1 only).

● With selector switch ⑬ 'TAPE MONITOR 1' or ⑭ 'TAPE MONITOR 2' pressed in. You hear the signal as it goes to the recorder heads. The strength of this signal is in this case partly dependent on the recording volume setting of the recorder.

Note: If the recorder used has separate heads for recording and playback, then it is possible to monitor the recording. See the recorder manual.

Was the recording unsuccessful?

- If the recording could be followed without disturbance with selector switch ⑬ or ⑭ pressed in, failure can only be caused by improper use of the recorder.
- A faulty recording can also be the result of:
 - faulty operation of the signal source to be recorded.
 - if the 'SELECTOR' switch ④ is activated.
 - if the 'CD DIRECT' switch ⑬ is activated.

Dubbing tapes

Using button ⑮ 'TAPE COPY 1 → 2' a tape can be dubbed from recorder 1 to recorder 2.

Using button ⑯ 'TAPE COPY 2 → 1' a tape can be dubbed from recorder 2 to recorder 1.

In the meantime it is possible, if desired, to listen to another sound source.

- Press dubbing button ⑮ or ⑯.
- Playback with recorder 'TAPE 1' or 'TAPE 2'.
- Record simultaneously with recorder 'TAPE 2' or 'TAPE 1'.

The dubbing process can be followed by pressing switches ⑬ or ⑭. The corresponding indicator lights up. If you wish to listen to another sound source at the same time, then set the 'SELECTOR' switch ④ to the appropriate position.

Do not forget here to release switch ⑬ or ⑭ if it has been pressed in.

Note: While dubbing is taking place, dubbing button ⑮ or ⑯ should not be pressed. After dubbing is completed the pressed dubbing button should be released.

GENERAL INFORMATION

Connection of speakers

Speakers (impedance 4 to 16 ohms if only system 1 or system 2 is used or speakers with an impedance of 8 to 16 ohms if system 1 and system 2 are used) must be connected in pairs to the speaker connections ① 'SPEAKERS'.

In order to do this, the wires of the speaker cords should be prepared i.e. stripped of their insulation (± 5 mm) and core wires should be intertwined. To do this remove the speaker plugs if necessary. If you do not wish to do this, use suitable adapter cords.

One of the two wires of a speaker cord or adapter cord usually has a special distinguishing feature, i.e. a color, rib or other marking.

Bear this distinction in mind!

Connections

1. Insure that the amplifier is switched off!
2. Decide which group of terminals you are going to use (e.g. A).
3. Select the speaker to be connected (e.g. the left-hand one, 'L').

This determines which two wires are going to go into which two terminals.
4. Then put the marked wire in the red terminal, the unmarked wire in the black terminal (see Figs. 5a, 5b and 5c).

Tighten the speaker terminal firmly in order to keep the contact resistance between the terminal and the wire as small as possible.
5. Connect the wires of the other speaker (in this case the right-hand speaker, 'R') to the two other terminals (in this case A), in exactly the same way, i.e. the marked wire again in the red terminal, the unmarked wire in the black terminal. If you do not do this, the speakers will not work 'in phase'. The stereo playback will not be correct.
6. If a second pair of speakers is to be connected, connect them in exactly the same way to the remaining terminals (in this case terminals B).
7. Check that all connections have been made correctly:
 - Uninsulated wire ends must not touch each other (short circuit!).
 - The wires must not be loose in the terminals (tighten firmly).
8. Do not switch on the amplifier until you have insured that the volume control is not at MAX.

Positioning the speakers

In order to have as good a stereo effect as possible, take care when setting up the speakers. Because every room has its own limitations, the best position will only be found by experimentation.

Observe the following rules when experimenting:

- Seen from the listener's position, place the speaker connected to the 'L' terminals on the left and the speaker connected to the 'R' terminals on the right.
- Try to keep the distance between the speakers the same as that between each of the speakers and the listener's position.
- Bass reproduction is amplified by placing the speakers on the floor or in a corner.
- The placing of speakers behind obstacles (furniture, sunblinds, curtains, etc.) has an unfavourable effect on treble reproduction.
- Try to keep the arrangement and positioning height as symmetrical as possible.

Service

The outside of the amplifier can be cleaned with a damp cloth (not wet!). Use only water to dampen the cloth.

TECHNICAL DATA

(Subject to alteration)

- Power output acc. to FTC
at 8 ohm load
(20-20.000 Hz, D \leq 0.03%): 100 W continuous sine wave
- Power output acc. to IEC
at 8 ohm load
(63-12.500 Hz, D \leq 0.3%): 115 W continuous sine wave
- IHF music power
at 8 ohm load: 120 W
at 4 ohm load: 225 W
at 2 ohm load: 280 W
- Harmonic distortion (1 kHz): 0.008%
- Intermodulation distortion: 0.03%
- Power bandwidth (–3 dB): 10-30.000 Hz
- Frequency response: 40-20.000 Hz \pm 0,5 dB
- S/N ratio: 106 dB (weighted)
- Channel separation (1 kHz): 75 dB
- Damping factor at 8 ohms: 180 \times
- Input sensitivity:
Phono MC: 0.25 mV/100 ohm
Phono MM: 2,5 mV/47 kohm
Compact Disc: 150 mV/25 kohm
Tuner: 150 mV/25 kohm
TV1/Aux 1: 150 mV/25 kohm
Video 1/Aux 2: 150 mV/25 kohm
Tape 1: 150 mV/25 kohm
Tape 2: 150 mV/25 kohm
- Outputs:
Tape: 150 mV/220 ohm
2 sets of speakers: 8 ohm
Headphones: 8-1000 ohm
- Tone control:
bass: + 10 dB to – 10 dB at 100 Hz
treble: + 10 dB to – 10 dB at 10 kHz
- Loudness: + 6 dB at 100 Hz, + 4 dB at 10 kHz
- Balance control: 0-50 dB
- Power requirements: 2,5A/120 V AC/60 Hz

1

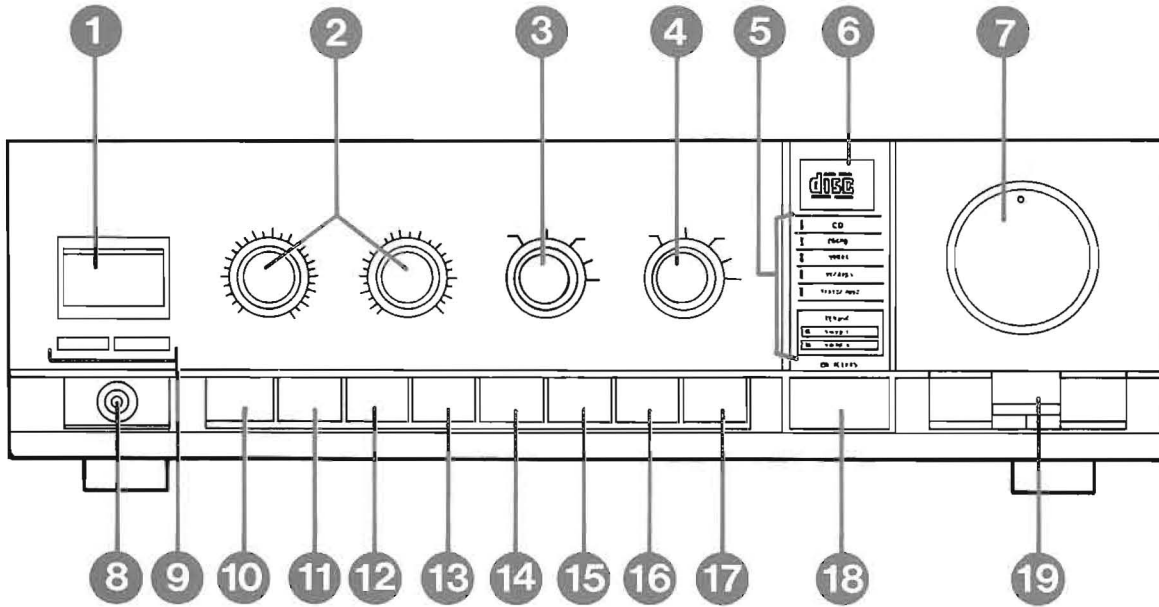

2

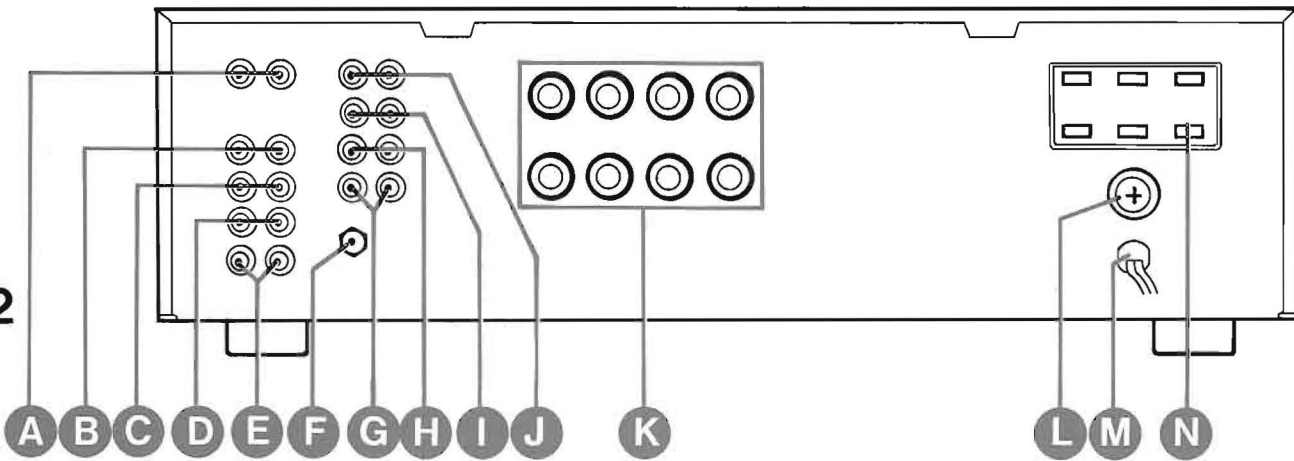

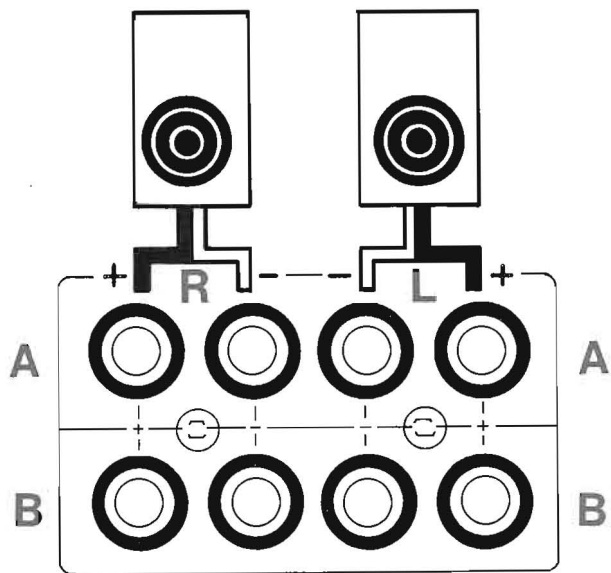

3

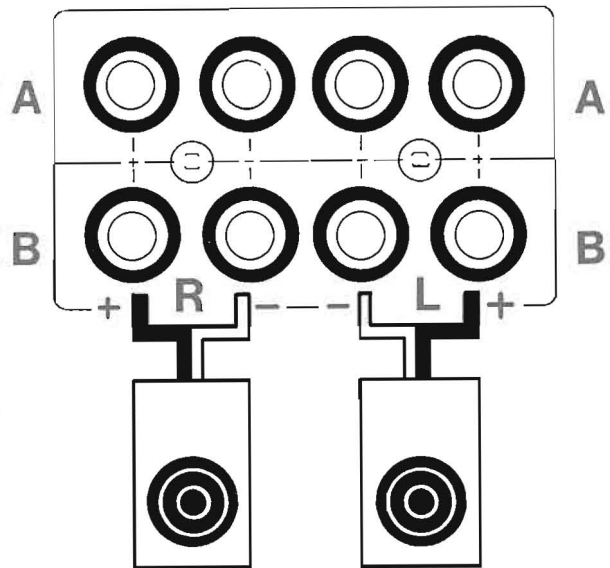

4

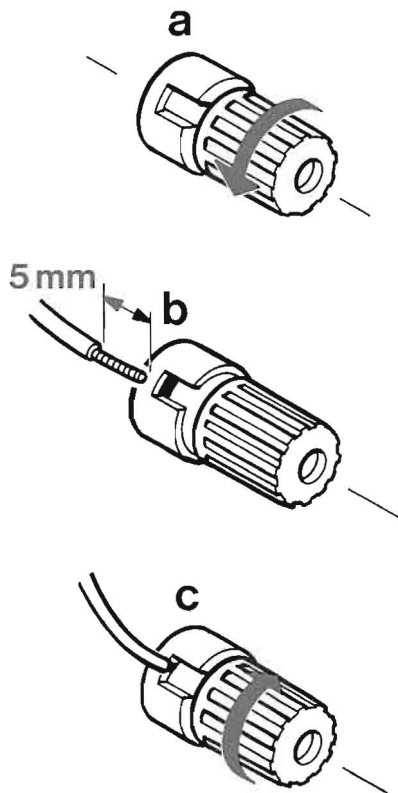

5



Knoxville, Tennessee 37914, U.S.A.

A NORTH AMERICAN PHILIPS COMPANY