

Service manual for KB compact stereo record player Model KP043

ITT Consumer Products Services Ltd.
FOOTSCRAY, SIDCUP, KENT
01-300 7733
32 Milton Road, East Kilbride, Glasgow
0355-2-25101

ITT

Service manual for KB compact stereo record player Model KP043

Dimensions :	Height 205mm (8 $\frac{1}{8}$ ") Width 625mm (24 $\frac{1}{2}$ ") Depth 371mm (14 $\frac{9}{16}$ ")
Weight :	10.2 kg (22 $\frac{1}{2}$ lb)
Power Supply :	200 V 240 V 50 Hz
Power Consumption :	30 W 45 V.A.
Power Output :	3.5 watts per channel at 10% distortion
Frequency Response :	—3 dB at 70 Hz and 15 kHz
Loudspeaker Impedance :	15 Ω
Transistor Complement Per Channel :	
	BC109 — Pre-amplifier
	BC187 — Driver
	AC128 } —Complementary symmetry push-pull output
	AC176 }
Bridge Rectifier :	FG66E/1B
Controls :	
	Volume
	Balance
	Bass
	Treble
	On/Off

CIRCUIT DESCRIPTION

The signal from the cartridge passes first to the bass control Ra2/Ra19 which functions by resistively loading the capacitive source. The treble control cuts the high frequencies when the slider is towards the end of the control connected to Ra4/Ra21. The balance control Ra17 functions by progressively shorting the signal of one channel or the other to earth. The signal is applied to the volume control Ra5/Ra22 and is then fed to the input of TXa1/TXa5 which is high impedance. The amplified signal then passes to TXa2/TXa6 which drives the output stage. This stage consists of two transistors TXa3/TXa7 and TXa4/TXa8 operating in complementary symmetry. They function in the common emitter mode because Ra14/Ra30 is connected to the live terminal of the load.

D.C. and a.c. feedback is applied via Ra12/Ra28 from the output to the emitter of TXa1/TXa5. A large amount of d.c. feedback is applied to eliminate the need for any adjustment for correct working conditions.

The a.c. feedback is controlled by the networks Ra9/Ra25, Ca5/Ca12 and Ra12/Ra28, Ra11/Ra27, Ca6/Ca13.

Ra11/Ra27 and Ca6/Ca13 also provide some low frequency compensation.

CHASSIS REMOVAL INSTRUCTIONS

Remove the two screws from the top of the control panel. Lay a piece of cloth to cover the right-hand speaker compartment. Lift the control panel, with the attached chassis, out of the cabinet and lay it on top of the cloth.

To refit the control panel and chassis reverse the procedure.

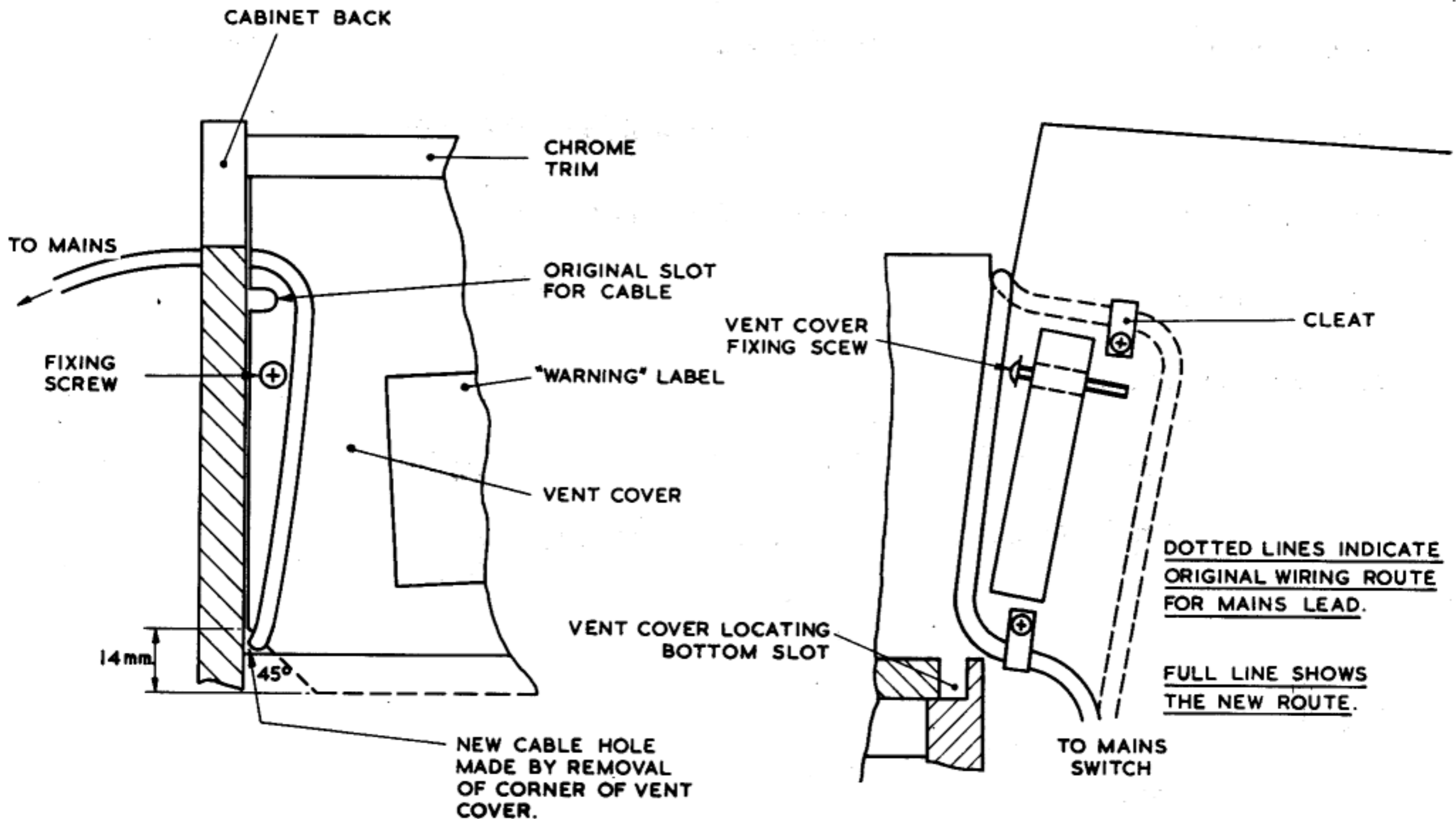

Modification to routing of mains lead. Sets must conform to this drawing.

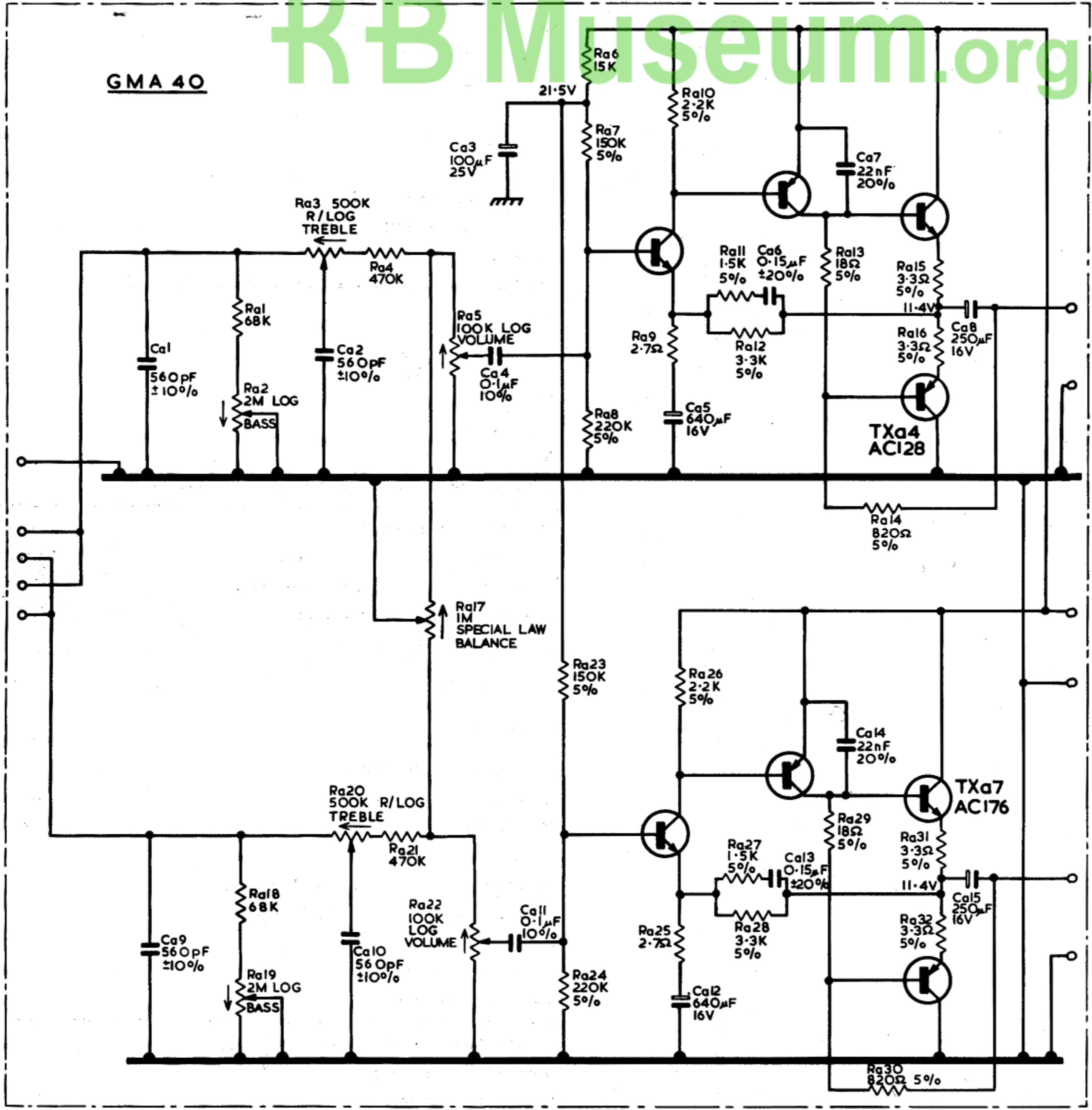

ALL VOLTAGES ARE POSITIVE AND ARE MEASURED WITH RESPECT TO THE NEGATIVE CHASSIS RAIL WITH AN AVO 8 ON THE 25V D.C. RANGE

TRANSISTOR BASE CONNECTIONS

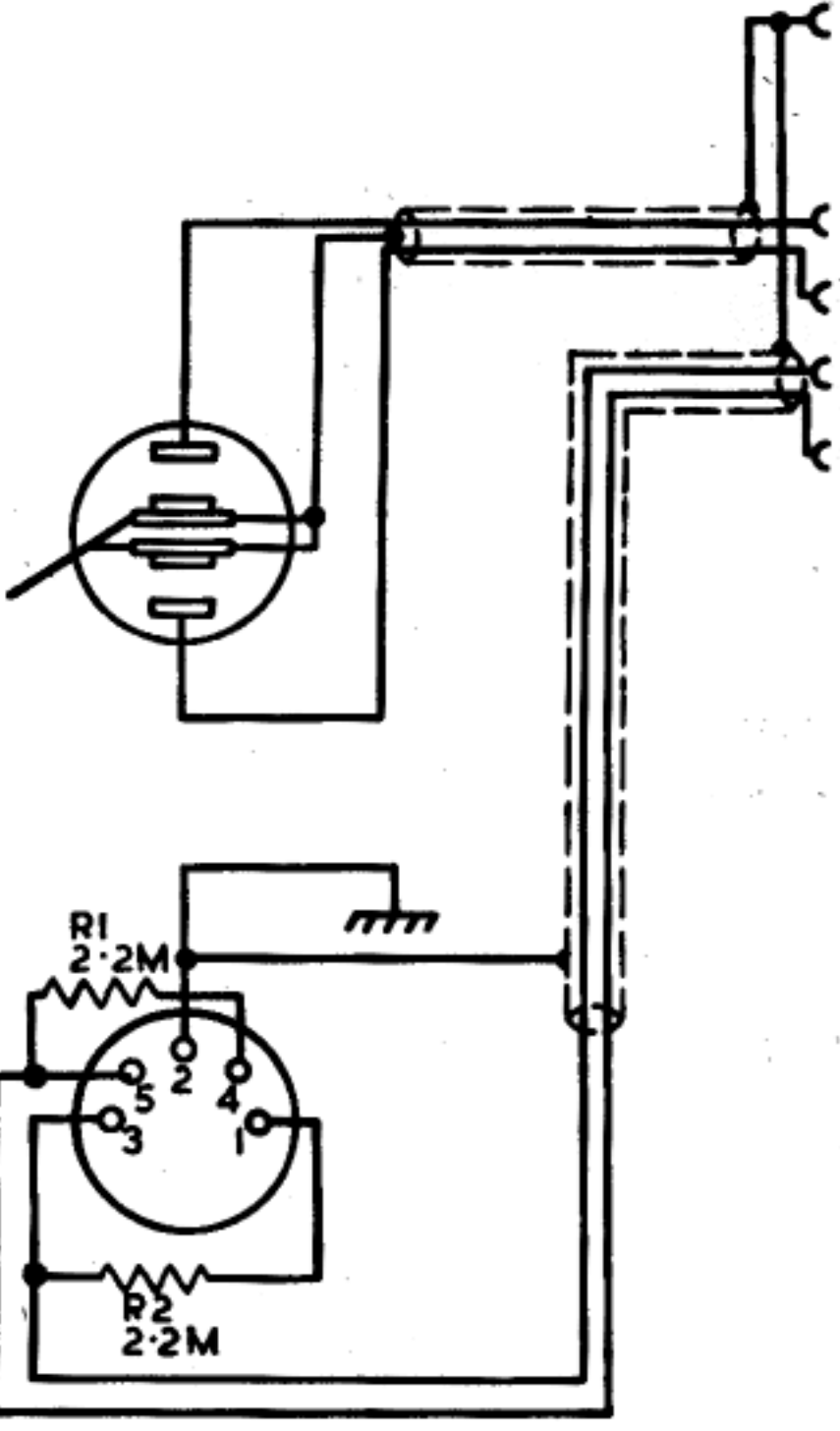
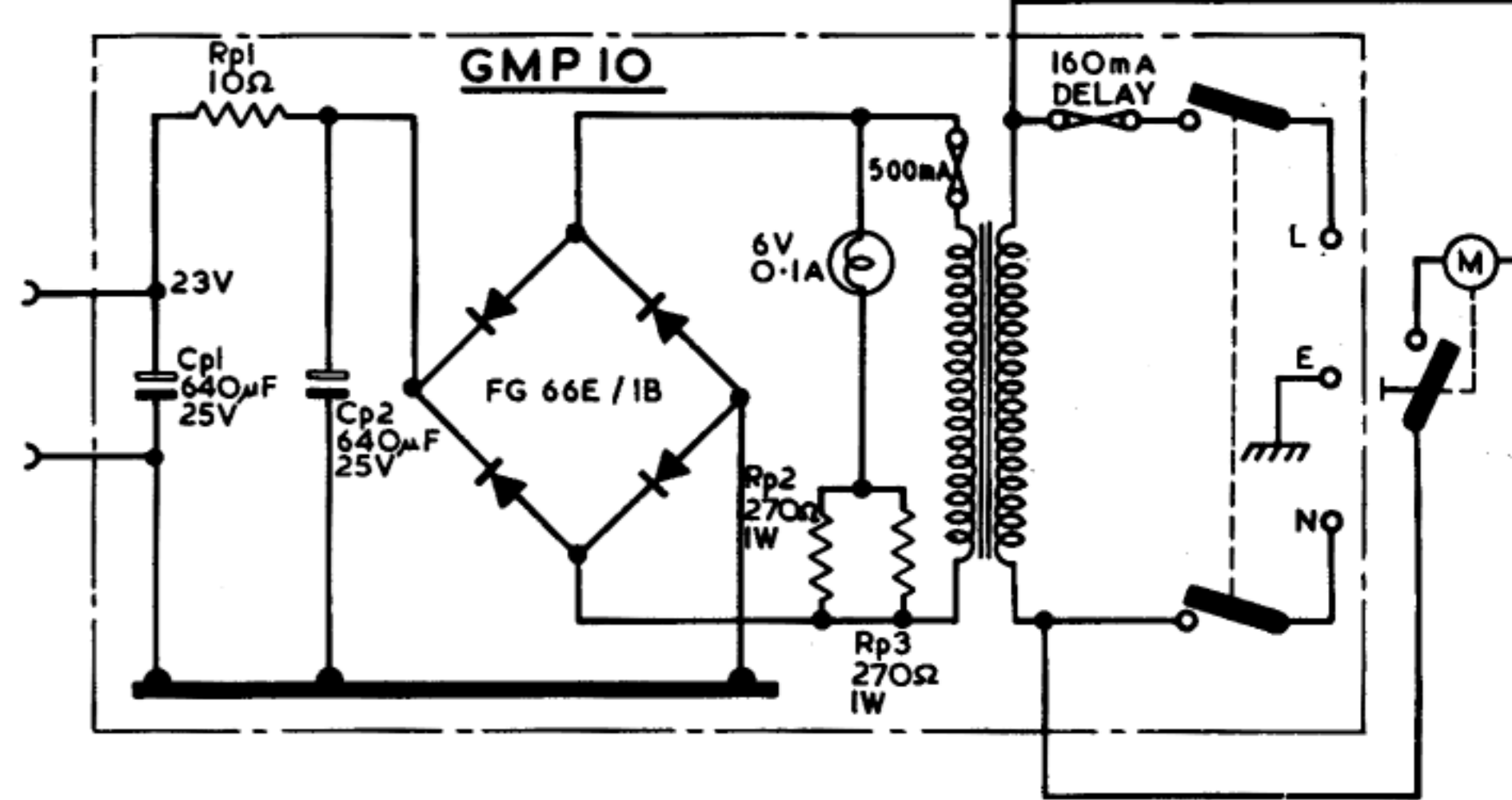
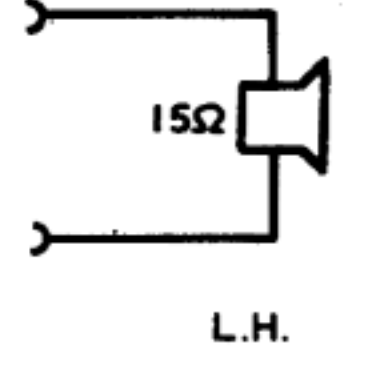
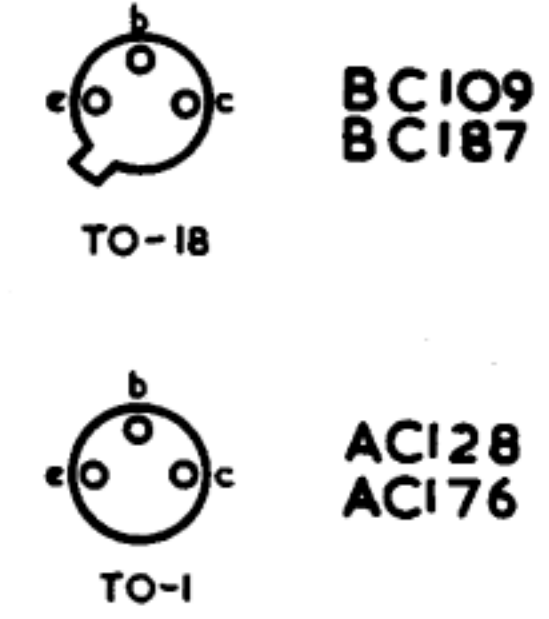

DIRECTION OF ARROW ON POTENTIOMETER INDICATES CLOCKWISE ROTATION OF SHAFT

ALL RESISTORS ARE 10% 1/2W UNLESS OTHERWISE STATED,

CIRCUIT DIAGRAM
KP043

TREBLE

BASS

BALANCE

VOLUME

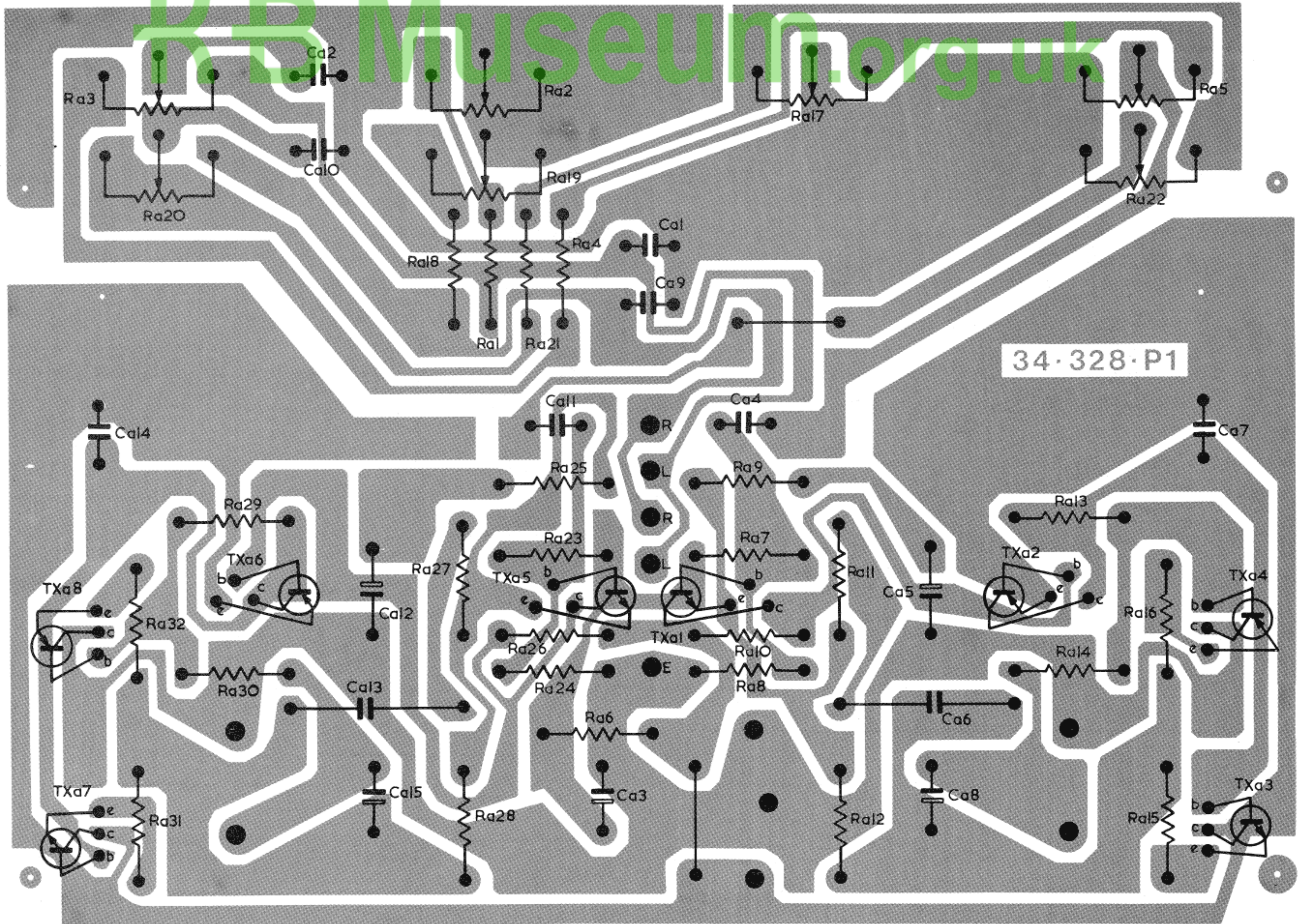

COMPONENT OVERLAY . FOR GMA 40