

# HEATHKIT<sup>®</sup> MANUAL

*for the*

**RLC BRIDGE**

Model IB-5281

595-1958-03

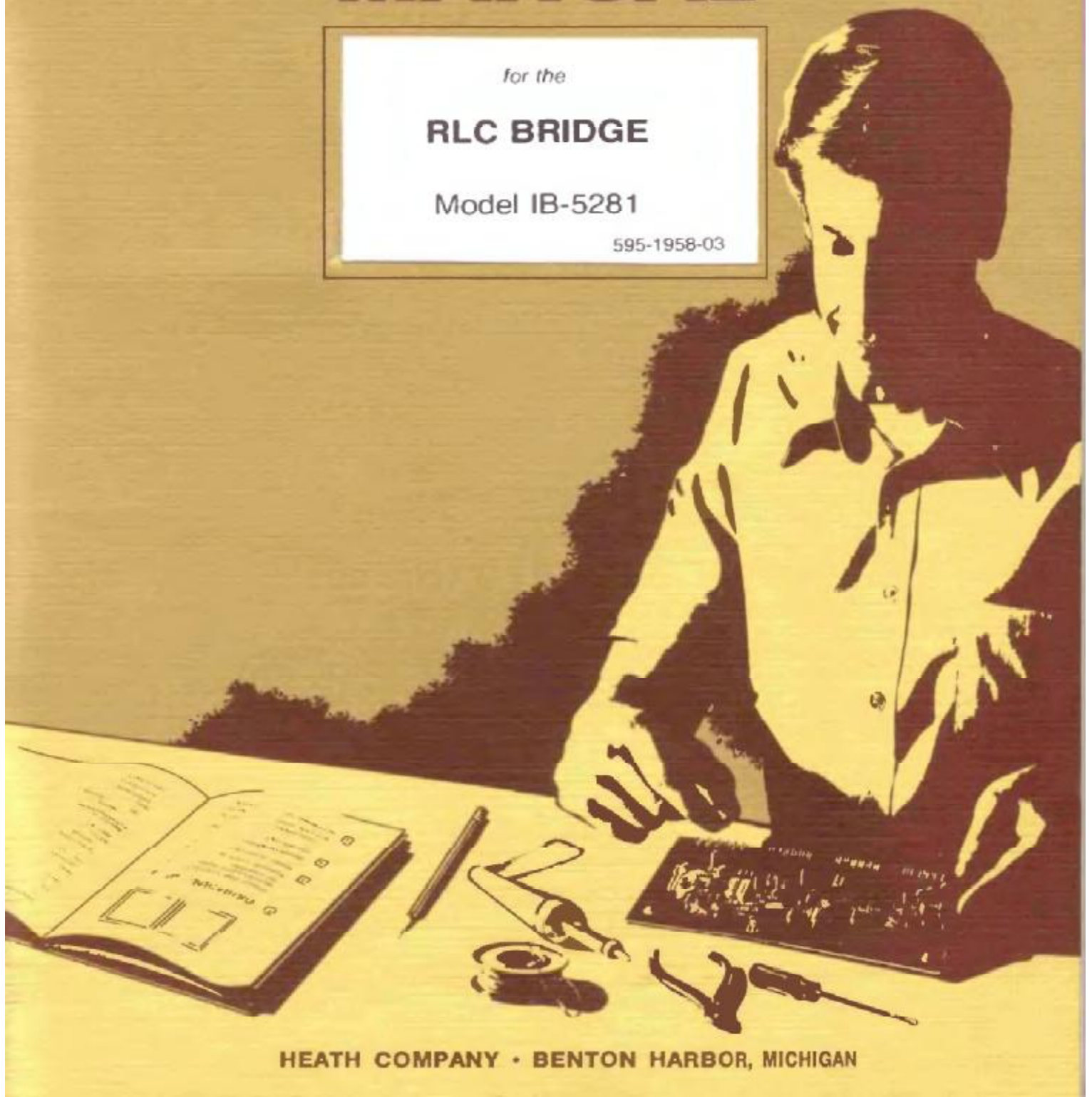

HEATH COMPANY • BENTON HARBOR, MICHIGAN

## HEATH COMPANY PHONE DIRECTORY

The following telephone numbers are direct lines to the departments listed:

Kit orders and delivery information ..... (616) 982-3411  
Credit ..... (616) 982-3561  
Replacement Parts ..... (616) 982-3571

### Technical Assistance Phone Numbers

8:00 A.M. to 12 P.M. and 1:00 P.M. to 4:30 P.M., EST, Weekdays Only

R/C, Audio, and Electronic Organs ..... (616) 982-3210  
Amateur Radio ..... (616) 982-3236  
Test Equipment, Weather Instruments and  
Home Clocks ..... (616) 982-3215  
Television ..... (616) 982-3307  
Aircraft, Marine, Security, Scanners, Automotive,  
Appliances and General Products ..... (616) 982-3496  
Computers — Hardware ..... (616) 982-3309  
Computers — Software:  
Operating Systems, Languages, Utilities ..... (616) 982-3860  
Applications Programs ..... (616) 982-3864  
Heath Craft Wood Works ..... (616) 982-3423



## YOUR HEATHKIT 90-DAY LIMITED WARRANTY

### Consumer Protection Plan for Heathkit Consumer Products

Welcome to the Heath family. We believe you will enjoy assembling your kit and will be pleased with its performance. Please read this Consumer Protection Plan carefully. It is a "LIMITED WARRANTY" as defined in the U.S. Consumer Product Warranty and Federal Trade Commission Improvement Act. This warranty gives you specific legal rights, and you may also have other rights which vary from state to state.

#### Heath's Responsibility

**PARTS** — Replacements for factory defective parts will be supplied free for 90 days from date of purchase. Replacement parts are warranted for the remaining portion of the original warranty period. You can obtain warranty parts direct from Heath Company by writing or telephoning us at (616) 982-3571. And we will pay shipping charges to get those parts to you... anywhere in the world.

**SERVICE LABOR** — For a period of 90 days from the date of purchase, any malfunction caused by defective parts or error in design will be corrected at no charge to you. You must deliver the unit at your expense to the Heath factory, any Heath Electronic Center (units of Veritechnology Electronics Corporation), or any of our authorized overseas distributors.

**TECHNICAL CONSULTATION** — You will receive free consultation on any problem you might encounter in the assembly or use of your Heathkit product. Just drop us a line or give us a call. Sorry, we cannot accept collect calls.

**NOT COVERED** — The correction of assembly errors, adjustments, calibration, and damage due to misuse, abuse, or negligence are not covered by the warranty. Use of corrosive solder and/or the unauthorized modification of the product or of any furnished component will void this warranty in its entirety. This warranty does not include reimbursement for inconvenience, loss of use, customer assembly, set-up time, or unauthorized service.

This warranty covers only Heath products and is not extended to other equipment or components that a customer uses in conjunction with our products.

**SUCH REPAIR AND REPLACEMENT SHALL BE THE SOLE REMEDY OF THE CUSTOMER AND THERE SHALL BE NO LIABILITY ON THE PART OF HEATH FOR ANY SPECIAL, INDIRECT, INCIDENTAL OR CONSEQUENTIAL DAMAGES, INCLUDING BUT NOT LIMITED TO ANY LOSS OF BUSINESS OR PROFITS, WHETHER OR NOT FORSEEABLE.**

Some states do not allow the exclusion or limitation of incidental or consequential damages, so the above limitation or exclusion may not apply to you.

#### Owner's Responsibility

**EFFECTIVE WARRANTY DATE** — Warranty begins on the date of first consumer purchase. You must supply a copy of your proof of purchase when you request warranty service or parts.

**ASSEMBLY** — Before seeking warranty service, you should complete the assembly by carefully following the manual instructions. Heathkit service agencies cannot complete assembly and adjustments that are customer's responsibility.

**ACCESSORY EQUIPMENT** — Performance malfunctions involving other non-Heath accessory equipment, (antennas, auto components, computer peripherals and software, etc.) are not covered by this warranty and are the owner's responsibility.

**SHIPPING UNITS** — Follow the packing instructions published in the assembly manuals. Damage due to inadequate packing cannot be repaired under warranty.

If you are not satisfied with our service (warranty or otherwise) or our products, write directly to our Director of Customer Service, Heath Company, Benton Harbor MI 49022. He will make certain your problems receive immediate, personal attention.

# Heathkit<sup>®</sup> Manual

*for the*

## RLC BRIDGE

Model IB-5281

595-1958-03

HEATH COMPANY  
BENTON HARBOR, MICHIGAN 49022

Copyright © 1977  
Heath Company  
*All Rights Reserved*  
Printed in the United States of America



**TABLE OF CONTENTS**

Introduction .....	3	In Case of Difficulty .....	36
Assembly Notes .....	4	Troubleshooting Chart .....	37
Parts List .....	7	Specifications .....	38
Step-By-Step Assembly		Circuit Description .....	38
Circuit Board Assembly .....	9	Circuit Board X-Ray View .....	40
Range Switch Wiring .....	19	Semiconductor Identification Chart .....	41
Chassis Assembly and Wiring .....	21		
Power Switch and Connector Wiring .....	27		
Initial Test and Adjustments .....	29		
Final Assembly .....	33	Schematic .....	Fold-in
Operation		Warranty .....	Inside Front Cover
Using the Bridge .....	35	Customer Service .....	Inside Rear Cover
Using an External Standard .....	35		

## INTRODUCTION

The Heathkit Model IB-5281 RLC Bridge is a general-purpose instrument that you can use to check the value of resistors, inductors, and capacitors. Use it for bench work with the optional power supply, or as a portable test unit for field use with two standard 9-volt batteries (not supplied). Terminals are provided on the front panel for the component under test ( $Z_x$ ), and an external standard ( $Z_s$ ).

The compact cabinet design matches the 5280 instrument series cabinets. Each cabinet has a convenient storage compartment that lifts for easy access to cables or accessories. The units may be stacked, or

placed side by side. This will help you to lay out a neat "test center" arrangement. Each kit in this series is designed for both battery and power supply operation.

The type 5280 series includes the Model IM-5284 Multimeter, the Model IPA-5280-1 Power Supply, and several other kits. If you have purchased the Multimeter, you may want to build it first so that it is available to check the other kits as you assemble them. You may want to build the power supply next to avoid the need for batteries.

### BATTERY

If you intend to use batteries, you should purchase two 9-volt transistor batteries, NEDA #1604 at this time for use in your kit. Representative manufacturers and their type numbers are:

Eveready #216, PP3  
Burgess #2U6  
Mallory #TR-146X (long life)  
RCA #VS323  
Hellesens #410  
Varta #438  
CEI #6F22

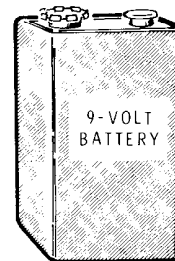



## ASSEMBLY NOTES

### TOOLS

You will need these tools to assemble your kit.

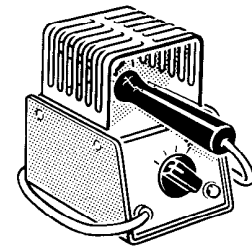
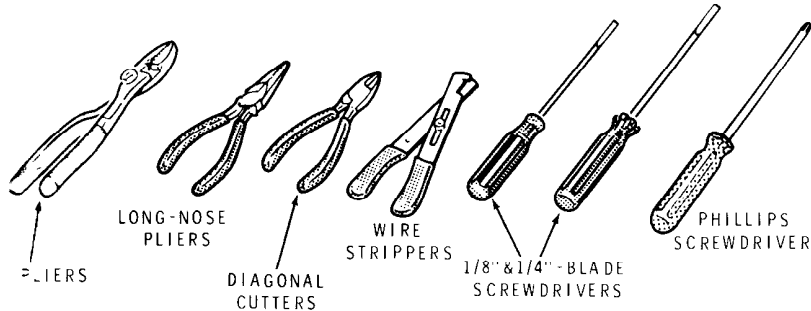

HEATHKIT  
SOLDERING  
IRON

OR

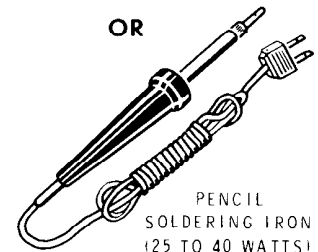

PENCIL  
SOLDERING IRON  
(25 TO 40 WATTS)

### OTHER HELPFUL TOOLS



NUT STARTER  
(MAY BE SUPPLIED  
WITH KIT)

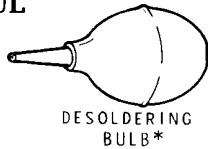

DESOLDERING  
BULB\*



DESOLDERING  
BRAID\*

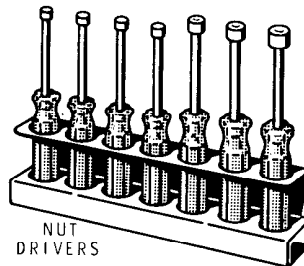

NUT  
DRIVERS

\*TO REMOVE SOLDER FROM CIRCUIT CONNECTIONS.

### ASSEMBLY

1. Follow the instructions carefully and read the entire step before you perform the operation.
2. The illustrations in the Manual are called Pictorials and Details. Pictorials show the overall operation for a group of assembly steps; Details generally illustrate a single step. When you are directed to refer to a certain Pictorial "for the following steps," continue using that Pictorial until you are referred to another Pictorial for another group of steps.
3. Most kits use a separate "Illustration Booklet" that contains illustrations (Pictorials, Details, etc.) that are too large for the Assembly Manual. Keep the "Illustration Booklet" with the Assembly Manual. The illustrations in it are arranged in Pictorial number sequence.
4. Position all parts as shown in the Pictorials.
5. Solder a part or a group of parts only when you are instructed to do so.



6. Each circuit part in an electronic kit has its own component number (R2, C4, etc.). Use these numbers when you want to identify the same part in the various sections of the Manual. These numbers, which are especially useful if a part has to be replaced, appear:
- In the Parts List,
  - At the beginning of each step where a component is installed,
  - In some illustrations,
  - In the Schematic,
  - In the section at the rear of the Manual.
7. When you are instructed to cut something to a particular length, use the scales (rulers) provided at the bottom of the Manual pages.

**SAFETY WARNING: Avoid eye injury when you cut off excess lead lengths. Hold the leads so they cannot fly toward your eyes.**

## SOLDERING

Soldering is one of the most important operations you will perform while assembling your kit. A good solder connection will form an electrical connection between two parts, such as a component lead and a circuit board foil. A bad solder connection could prevent an otherwise well-assembled kit from operating properly.

It is easy to make a good solder connection if you follow a few simple rules:

1. Use the right type of soldering iron. A 25 to 40-watt pencil soldering iron with a 1/8" or 3/16" chisel or pyramid tip works best.
2. Keep the soldering iron tip clean. Wipe it often on a wet sponge or cloth; then apply solder to the tip to give the entire tip a wet look. This process is called tinning, and it will protect the tip and enable you to make good connections. When solder tends to "ball" or does not stick to the tip, the tip needs to be cleaned and re-tinned.

**NOTE:** Always use rosin core, radio-type solder (60:40 or 50:50 tin-lead content) for all of the soldering in this kit. This is the type we have supplied with the parts. The Warranty will be void and we will not service any kit in which acid core solder or paste has been used.



**PARTS**

**Resistors** will be called out by their resistance value in  $\Omega$  (ohms),  $k\Omega$  (kilohms), or  $M\Omega$  (megohms). Certain types of resistors will have the value printed on the body, while others will be identified by a color code. The colors of the bands and the value will be given in the steps, therefore the following color code is given for information only.

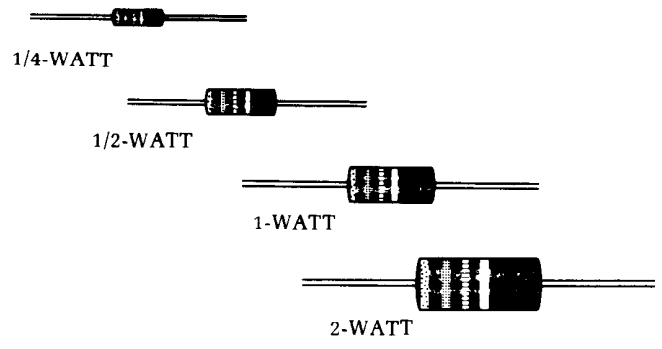

**EXAMPLES:**

BROWN 1  
GREEN 5  
ORANGE 1,000  
SILVER  $\pm 10\%$

$15 \times 1,000 = 15,000 \Omega$  (15,000 OHMS),  
or "15  $k\Omega$ "

ORANGE 3  
BLACK 0  
GREEN 100,000  
GOLD  $\pm 5\%$

$30 \times 100,000 = 3,000,000 \Omega$  (or 3  $M\Omega$ )  
3  $M\Omega = 3$  MEGOHMS

**RESISTOR COLOR CODE**

**TOLERANCE**  
Gold 5%  
Silver 10%  
No Band 20%

COLOR	1st DIGIT	2nd DIGIT	MULTIPLY BY
BLACK	0	0	1
BROWN	1	1	10
RED	2	2	100
ORANGE	3	3	1,000
YELLOW	4	4	10,000
GREEN	5	5	100,000
BLUE	6	6	1,000,000
VIOLET	7	7	10,000,000
GRAY	8	8	100,000,000
WHITE	9	9	1,000,000,000
GOLD			.1
SILVER			.01

**Capacitors** will be called out by their capacitance value in  $\mu F$  (microfarads) or pF (picofarads) and type: ceramic, Mylar\*, electrolytic, etc. Some capacitors may have their value printed in the following manner:

**EXAMPLES:**

$151K = 15 \times 10 = 150 \text{ pF}$   
 $759 = 75 \times 0.1 = 7.5 \text{ pF}$

**NOTE:** The letter "R" may be used at times to signify a decimal point, as in: 2R2 = 2.2 (pF or  $\mu F$ ).

First digit of capacitor's value: 1

Second digit of capacitor's value: 5

Multiplier: Multiply the first & second digits by the proper value from the Multiplier Chart.

To find the tolerance of the capacitor, look up this letter in the Tolerance columns.

MULTIPLIER		TOLERANCE OF CAPACITOR		
FOR THE NUMBER:	MULTIPLY BY:	10pF OR LESS	LETTER	OVER 10pF
0	1	$\pm 0.1\text{pF}$	B	
1	10	$\pm 0.25\text{pF}$	C	
2	100	$\pm 0.5\text{pF}$	D	
3	1000	$\pm 1.0\text{pF}$	F	$\pm 1\%$
4	10,000	$\pm 2.0\text{pF}$	G	$\pm 2\%$
5	100,000		H	$\pm 3\%$
			J	$\pm 5\%$
8	0.01		K	$\pm 10\%$
9	0.1		M	$\pm 20\%$

\*DuPont Registered Trademark



## PARTS LIST

Check each part against the following list. The key numbers in the Parts List correspond to the numbers on the Parts Pictorial (Illustration Booklet, Page 1). Parts may vary slightly from the illustrations; only the hardware is shown actual size.

Some parts are packaged in containers with the part number marked on the outside. Except for the initial parts check, keep these parts in their containers so they can be easily identified when they are called for in the assembly steps.

Save all packaging material until all parts have been located.

To order a replacement part, use the Parts Order Form furnished with this kit. If a Parts Order Form is not available, refer to "Replacement Parts" inside the rear cover of this Manual. For prices, refer to the separate "Heath Parts Price List."

KEY No.	HEATH Part No.	QTY.	DESCRIPTION	CIRCUIT Comp. No.
---------	----------------	------	-------------	-------------------

### RESISTORS

NOTE: The following resistors have a tolerance of 5%. 5% is indicated by a fourth color band of gold. The resistors may be packed in more than one envelope.

A1	6-220	2	22 Ω (red-red-black)	R21, R22
A1	6-300	3	30 Ω (orange-black-black)	R36, R41, R42
A1	6-910	1	91 Ω (white-brown-black)	R37
A1	6-101	4	100 Ω (brown-black-brown)	R13, R27, R48, Cal.
A1	6-201	3	200 Ω (red-black-brown)	R32, R50, R52
A1	6-391	1	390 Ω (orange-white-brown)	R15
A1	6-471	2	470 Ω (yellow-violet-brown)	R11, R51
A1	6-511	3	510 Ω (green-brown-brown)	R35, R45, R46
A1	6-561	1	560 Ω (green-blue-brown)	R12
A1	6-102	3	1000 Ω (brown-black-red)	R23, R34, R53
A1	6-202	2	2000 Ω (red-black-red)	R39, R44
A1	6-242	1	2400 Ω (red-yellow-red)	R47
A1	6-302	1	3000 Ω (orange-black-red)	R49
A1	6-432	2	4300 Ω (yellow-orange-red)	R2, R5
A1	6-472	1	4700 Ω (yellow-violet-red)	R10
A1	6-622	1	6200 Ω (blue-red-red)	R43
A1	6-682	1	6800 Ω (blue-gray-red)	R38
A1	6-822	1	8200 Ω (gray-red-red)	R16
A1	6-103	1	10 kΩ (brown-black-orange)	R28

KEY No.	HEATH Part No.	QTY.	DESCRIPTION	CIRCUIT Comp. No.
---------	----------------	------	-------------	-------------------

### Resistors (cont'd.)

A1	6-183	1	18 kΩ (brown-gray-orange)	R40
A1	6-333	1	33 kΩ (orange-orange-orange)	R8
A1	6-433	2	43 kΩ (yellow-orange-orange)	R3, R6
A1	6-104	4	100 kΩ (brown-black-yellow)	R7, R20, R25, R30
A1	6-124	1	120 kΩ (brown-red-yellow)	R17
A1	6-224	2	220 kΩ (red-red-yellow)	R18, R19
A1	6-434	3	430 kΩ (yellow-orange-yellow)	R1, R4, R31
A1	6-105	1	1 MΩ (brown-black-green)	R29

### CAPACITORS

B1	20-102	1	100 pF mica	C7
B2	21-722	2	330 pF ceramic	C1, C2
B2	21-56	1	470 pF ceramic	C12
B2	21-140	2	.001 uF ceramic	C10, C11
B3	25-116	3	50 uF electrolytic	C14, C15, C16
B3	25-117	7	100 uF electrolytic	C3, C13, C17, C18, C19, C20, C21
B4	27-2	1	1 uF Mylar	C9
B5	27-47	3	.1 uF Mylar	C4, C5, C6
B6	29-2	1	10,000 pF (.01 μF) polystyrene	C8



KEY No.	HEATH Part No.	QTY.	DESCRIPTION	CIRCUIT Comp. No.
---------	----------------	------	-------------	-------------------

### CONTROLS-SWITCHES

C1	10-918	1	500 $\Omega$ control	R14
C1	10-11	1	5000 $\Omega$ control	R33
C1	10-941	1	100 k $\Omega$ control	R9
C2	10-1017	1	1000 $\Omega$ control	R24
C3	11-157	1	1000 $\Omega$ control	R26
C4	60-71	1	Slide switch	SW1
C5	63-1303	1	Rotary switch	SW2

### DIODES-TRANSISTORS

D1	56-56	3	1N4149 diode	D1, D2, D3
D1	56-89	2	GD510 diode	D4, D5

NOTE: Transistors are marked for identification in one of the following four ways:

1. Part number.
2. Type number.
3. Part number and type number.
4. Part number with a type number other than the one listed.

D2	417-94	2	2N3416 transistor	Q6, Q8
D3	417-235	5	2N4121 transistor	Q3, Q5, Q7, Q9, Q10
D3	417-291	2	2N5458 transistor	Q1, Q2
D3	417-801	1	MPSA20 transistor	Q4

### CHOKES - TRANSFORMER

E1	45-99	1	100 $\mu$ H choke	L1
E2	45-601	1	10 mH choke	L2
E3	46-66	1	1 H choke	L3
E4	51-98	1	Transformer	T1

### CONNECTOR - JACKS - PLUG

F1	432-798	2	Battery connector
F2	436-11	2	Red banana jack
F2	436-22	2	Black banana jack
F3	438-14	2	Alligator clip w/banana plug

KEY No.	HEATH Part No.	QTY.	DESCRIPTION	CIRCUIT Comp. No.
---------	----------------	------	-------------	-------------------

### HARDWARE

G1	250-56	10	6-32 x 1/4" screw
G2	250-592	2	#6 x 3/8" self-tapping screw
G3	250-162	5	6-32 x 1/2" screw
G4	250-1150	2	6-32 x 1/2" phillips-head screw
G5	252-3	10	6-32 nut
G6	254-1	10	#6 lockwasher
G7	250-22	1	8-32 x 7/16" setscrew
G8	252-7	2	Control nut
G9	252-195	5	Self-retaining nut
G10	253-10	2	Control flat washer
G11	254-5	2	Control lockwasher

### WIRE

343-15	1'6"	Shielded cable
344-50	3'	Black wire
344-52	4'	Red wire
344-55	2'6"	Green wire
344-59	3'	White wire

### MISCELLANEOUS

H1	73-64	2	Double-stick foam tape	
H2	73-142	2	Foam square	
	85-1919-1	1	Circuit board	
H3	92-662	1	Cabinet consisting of:	
	92-659	1	Cabinet top	
	92-660	1	Cabinet bottom	
	92-661	1	Cabinet cover (assembled to top)	
	92-668	1	Cover plate	
H4	200-1290	1	Chassis	
H5	203-1869-1	1	Front panel	
H6	206-1256	1	Bottom shield	
H7	206-1257	1	Top shield	
H8	204-2159	2	Meter clamp	
H9	391-34	1	Blue-and-white label	
H10	407-719	1	Meter	M1
H11	455-50	1	Knob bushing	
H12	462-140	1	Small knob	
	462-314	1	Large knob	
H13	463-28	1	Pointer	
	597-260	1	Parts Order Form	
		1	Assembly Manual (see Page 1) for Part Number)	
			Solder	

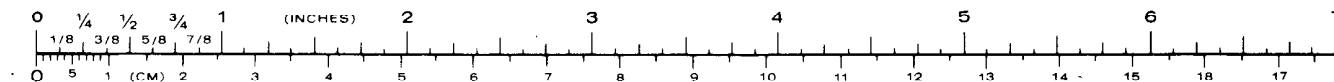



## STEP-BY-STEP ASSEMBLY

### CIRCUIT BOARD ASSEMBLY

#### START

In the following steps, you will be given detailed instructions on how to install and solder the first part on the circuit board. Read and perform each step carefully. Then use the same procedure whenever you install parts on the circuit board.

(✓) Position the circuit board as shown with the printed side (not the foil side) up.

( ) R49: Hold a 3000  $\Omega$  (orange-black-red) resistor by the body as shown and bend the leads straight down.

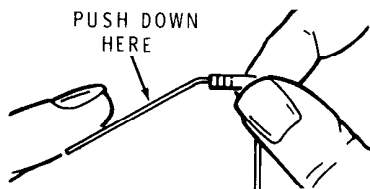

(✓) Push the leads through the holes at the indicated location on the circuit board. The end with color bands may be positioned either way.

(✓) Press the resistor against the circuit board. Then bend the leads outward slightly to hold the resistor in place.

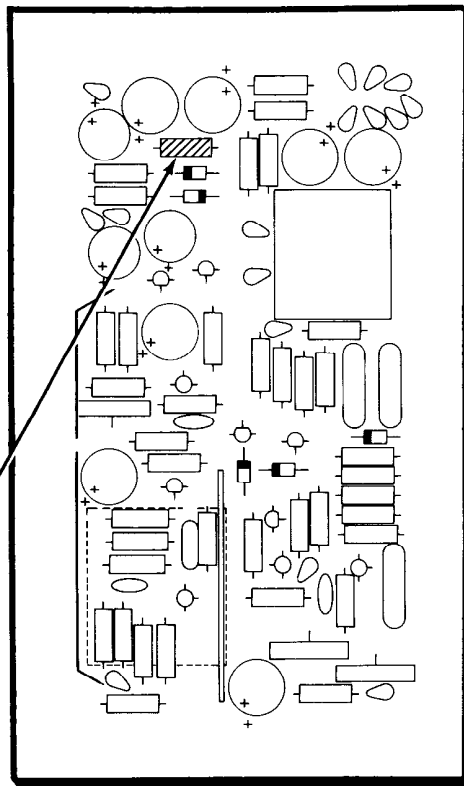

#### CONTINUE

(✓) Solder the resistor leads to the circuit board as follows:

1. Push the soldering iron tip against both the lead and the circuit board foil. Heat **both** for two or three seconds.

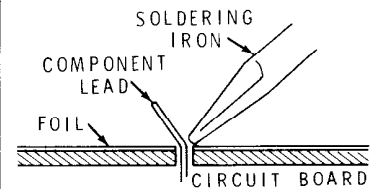

2. Then apply solder to the other side of the connection. **IMPORTANT:** Let the heated lead and the circuit board foil melt the solder.

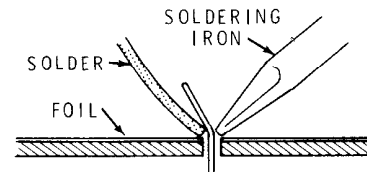

3. As the solder begins to melt, allow it to flow around the connection. Then remove the solder and the iron and let the connection cool.

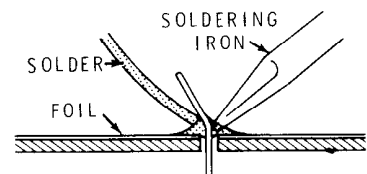

(✓) Cut off the excess lead lengths close to the connection. **WARNING:** Clip the leads so the ends will not fly toward your eyes.

(✓) Check each connection. Compare it to the illustrations on Page 10. After you have checked the solder connections, proceed with the assembly on Page 11. Use the same soldering procedure for each connection.

PICTORIAL 1-1

### A GOOD SOLDER CONNECTION

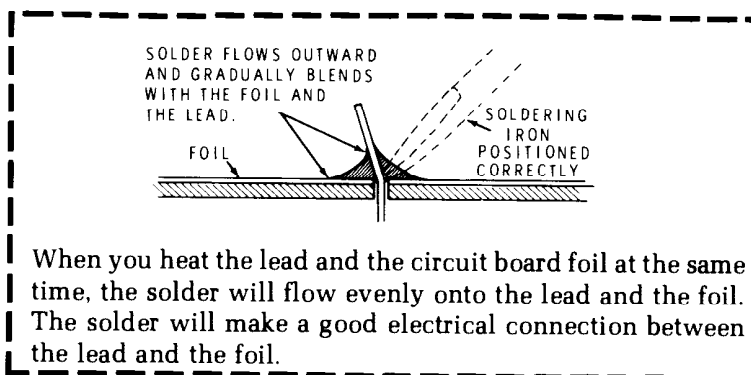

### POOR SOLDER CONNECTIONS

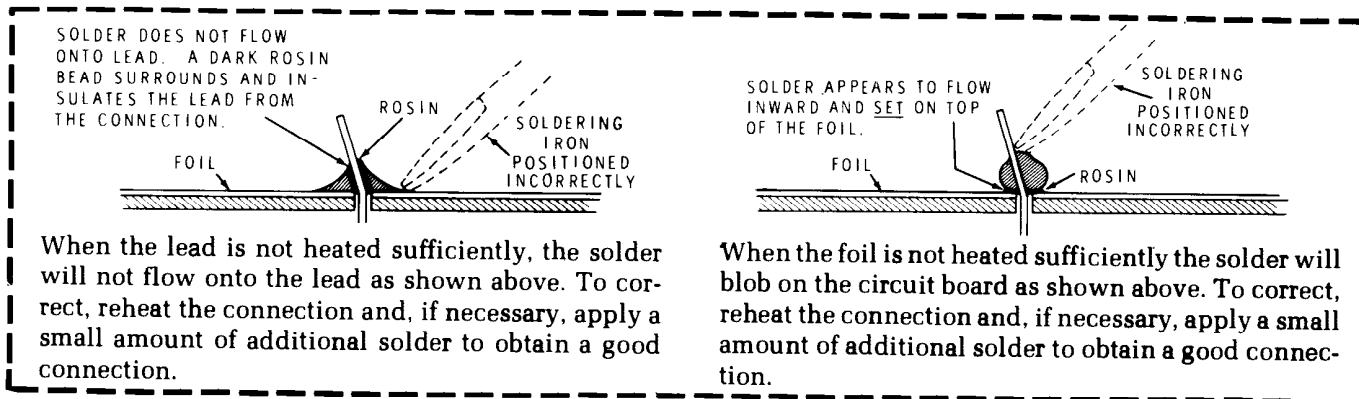

### SOLDER BRIDGES

A solder bridge between two adjacent foils is shown in photograph A. Photograph B shows how the connection should appear. A solder bridge may occur if you accidentally touch an adjacent previously soldered connection, if you use too much solder, or if you "drag" the soldering iron across other foils as you remove it from the connection. A good rule to follow is; always take a good look at the foil area around each lead before you solder it. Then, when you solder the connection, make sure the solder remains in this area and does not bridge to another foil. This is especially important when the foils are small and close together. NOTE: It is alright for solder to bridge two connections on the same foil.

Use only enough solder to make a good connection, and lift the soldering iron straight up from the circuit board. If a solder bridge should develop, turn the circuit board foil-side-down and heat the solder between connections. The excess solder will run onto the tip of the soldering iron, and this will remove the solder bridge. NOTE: The foil side of the circuit board has a coating on it called "solder resist." This is a protective insulation to help prevent solder bridges.

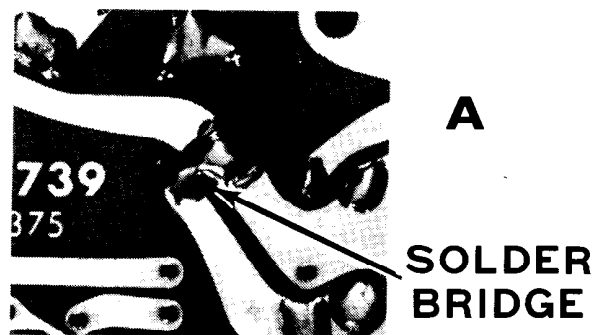

**START** →

NOTE: When you install a diode, always match the band on the diode with the band mark on the circuit board. THE CIRCUIT WILL NOT WORK IF THE DIODE IS INSTALLED BACKWARDS. See Detail 1-2A.

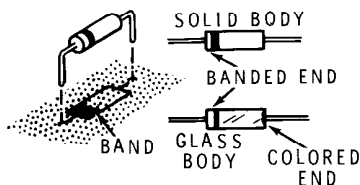

If your diode has a solid body, the band is clearly defined. If your diode has a glass body, do not mistake the colored end inside the diode for the banded end. Look for a band painted on the outside of the glass.

**IMPORTANT: THE BANDED END OF DIODES CAN BE MARKED IN A NUMBER OF WAYS.**

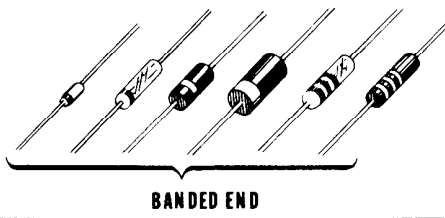

**BANDED END**  
Detail 1-2A

D5: GD510 diode (#56-89).

R46: 510 Ω (green-brown-brown).

R45: 510 Ω (green-brown-brown).

D4: GD510 diode (#56-89).

R44: 2000 Ω (red-black-red).

R48: 100 Ω (brown-black-brown).

R47: 2400 Ω (red-yellow-red).

R43: 6200 Ω (blue-red-red).

R40: 18 kΩ (brown-gray-orange).

Solder the leads to the foil and cut off the excess lead lengths.

NOTE: To prepare a wire as in the following step, cut the wire to the indicated length and remove 1/4" of insulation from each end.

Prepare a 3-3/4" white wire.

3-3/4" white wire.

Solder the leads to the foil and cut off the excess lead lengths.

**CONTINUE** →

R51: 470 Ω (yellow-violet-brown).

R53: 1000 Ω (brown-black-red).

R52: 200 Ω (red-black-brown).

R50: 200 Ω (red-black-brown).

R16: 8200 Ω (gray-red-red).

R22: 22 Ω (red-red-black).

R23: 1000 Ω (brown-black-red).

R21: 22 Ω (red-red-black).

R12: 560 Ω (green-blue-brown).

Solder the leads to the foil and cut off the excess lead lengths.

R25: 100 kΩ (brown-black-yellow).

R20: 100 kΩ (brown-black-yellow).

R18: 220 kΩ (red-red-yellow).

R19: 220 kΩ (red-red-yellow).

R17: 120 kΩ (brown-red-yellow).

Solder the leads to the foil and cut off the excess lead lengths.

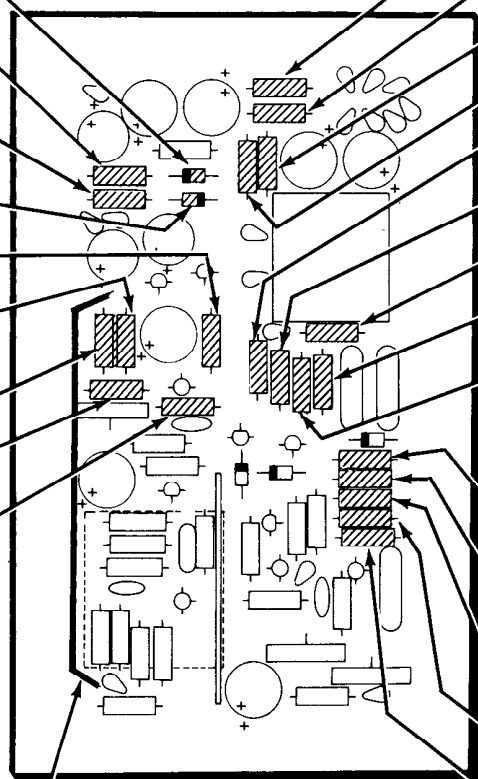

**PICTORIAL 1-2**

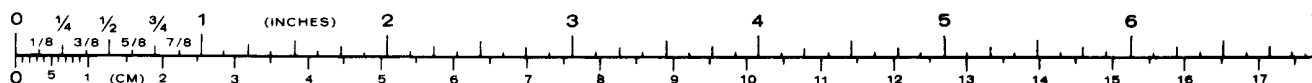

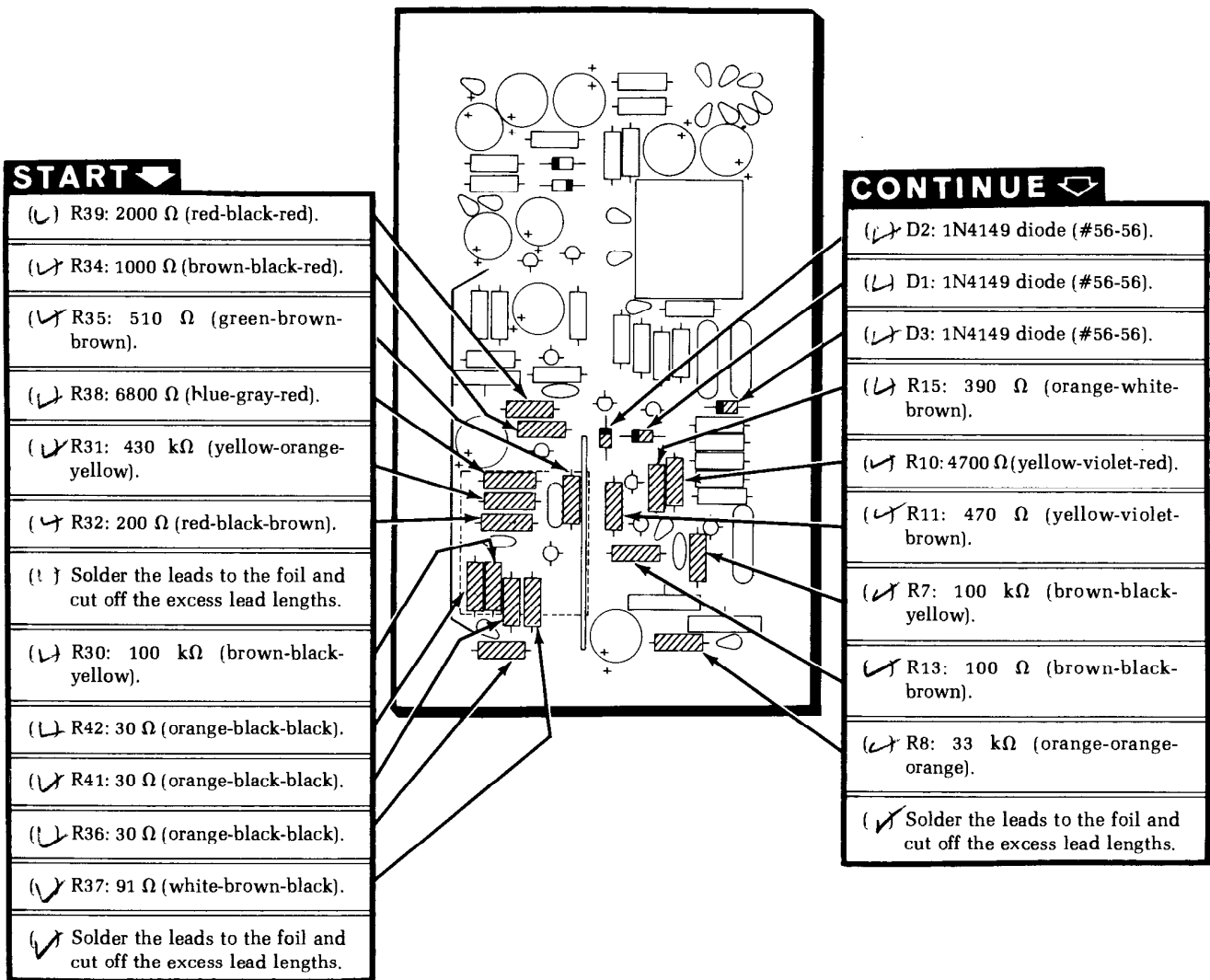

PICTORIAL 1-3

**START** ▾

In the following steps, install each transistor as follows:

1. Refer to the illustration below and identify the E, B, and C leads of the transistor.
2. Insert the transistor leads into the corresponding E, B, and C holes in the circuit board.
3. Position the transistor 1/4" above the circuit board.
4. Turn the circuit board over, solder the leads to the foil, and cut off the excess lead lengths.

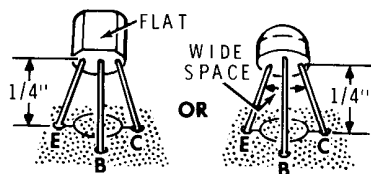

(✓) Q10: 2N4121 transistor (#417-235).

(✓) Q9: 2N4121 transistor (#417-235).

(✓) Q7: 2N4121 transistor (#417-235).

**IMPORTANT:** When you install the E, C, and B leads of the following transistors, notice that the lead configuration between the above type of transistor and this type are different. Also note that the center lead is bent **BACK** instead of forward, as in the previous steps.

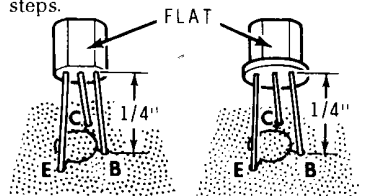

(✓) Q8: 2N3416 transistor (#417-94).

(✓) Q6: 2N3416 transistor (#417-94).

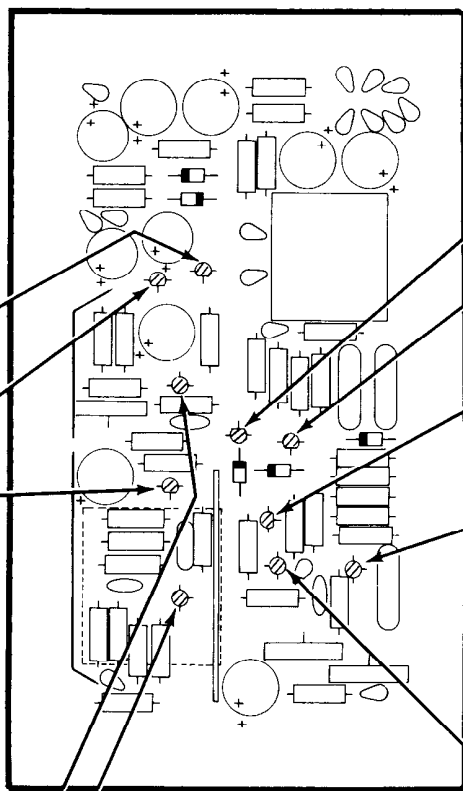

**CONTINUE** ▾

(✓) Q5: 2N4121 transistor (#417-235). NOTE: See the drawing in the top left column.

(✓) Q4: MPSA20 transistor (#417-801). NOTE: See the drawing in the top left column.

(✓) Q3: 2N4121 transistor (#417-235). NOTE: See the drawing in the top left column.

(✓) 2N5458 transistor (#417-291) at Q2.

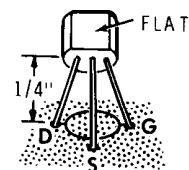

(✓) Q1: 2N5458 transistor (#417-291).

PICTORIAL 1-4



**START**

NOTE: Before you install an electrolytic capacitor, look at it and identify the leads. One lead will have a positive (+) mark or a negative (-) mark near it. Be sure to install the positive lead in the positive-marked hole. Be careful; only the negative lead may be marked.

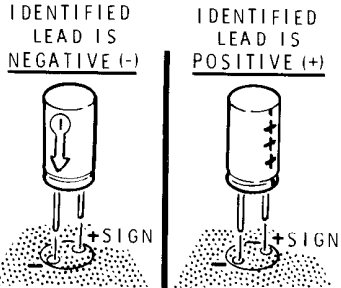

- C19: 100  $\mu$ F electrolytic.
- C16: 50  $\mu$ F electrolytic.
- C15: 50  $\mu$ F electrolytic.
- C14: 50  $\mu$ F electrolytic.
- C17: 100  $\mu$ F electrolytic.
- C13: 100  $\mu$ F electrolytic.

NOTE: When you install ceramic capacitors, do not push the insulated portions of the leads into the circuit board holes. This could make it difficult to solder the leads to the foil.

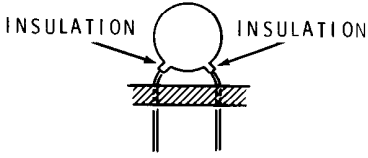

- C12: 470 pF ceramic.
- C10: .001  $\mu$ F ceramic.
- C11: .001  $\mu$ F ceramic.
- Solder the leads to the foil and cut off the excess lead lengths.

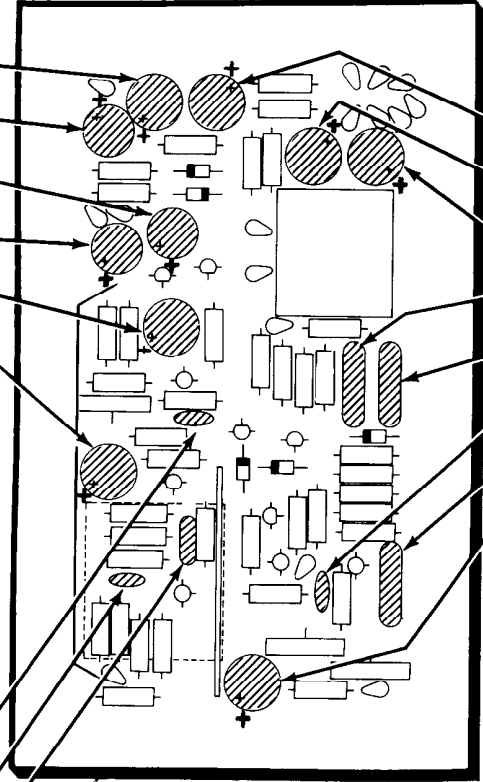

**CONTINUE**

- C21: 100  $\mu$ F electrolytic.
- C20: 100  $\mu$ F electrolytic.
- C18: 100  $\mu$ F electrolytic.
- C6: .1  $\mu$ F Mylar.
- C5: .1  $\mu$ F Mylar.
- C2: 330 pF ceramic.
- C4: .1  $\mu$ F Mylar.
- C3: 100  $\mu$ F electrolytic.
- Solder the leads to the foil and cut off the excess lead lengths.

PICTORIAL 1-5

**START** ↘

(✓) T1: AF transformer (#51-98).  
Solder the pins to the foil and cut off the excess pin lengths.

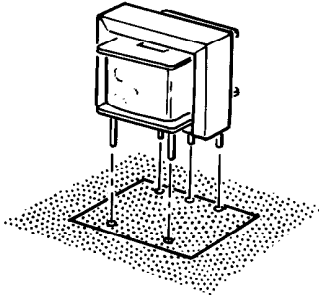

(✓) R33: 5 kΩ control (#10-311).  
Solder each control to the foil as you install it.

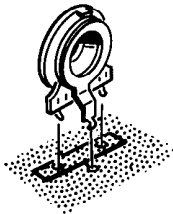

(✓) R9: 100 kΩ control (#10-941).

(✓) R14: 500 Ω control (#10-918).

(✓) Top shield. Insert the lugs through the circuit board holes and solder them to the foil. Make sure the shield is pressed firmly against the circuit board and is straight.

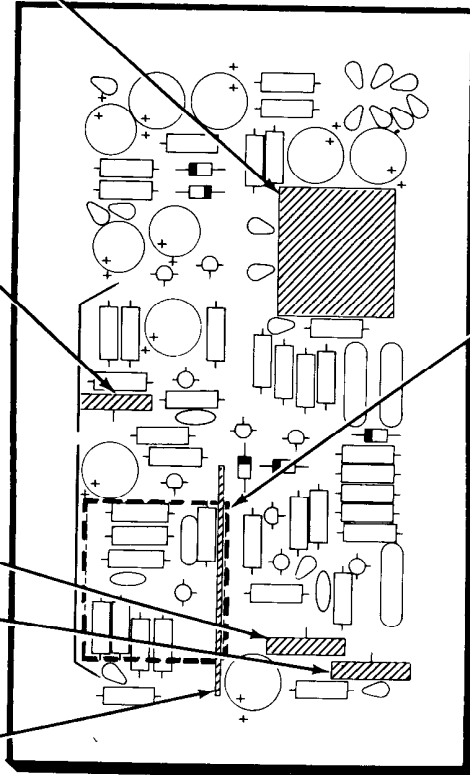
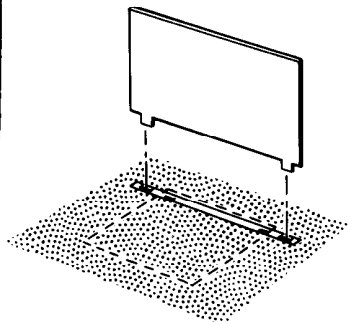

**CONTINUE** ↘

Position the circuit board with the foil side facing up.

NOTE: Before you perform the following step, check both sides of the circuit board inside the dotted line area to make sure there are no solder bridges or components interchanged.

(✓) Bottom shield: Insert the four lugs through the holes in the circuit board and solder them to the foil.

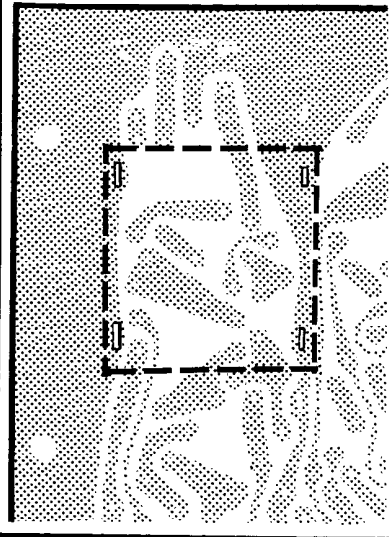

PICTORIAL 1-6

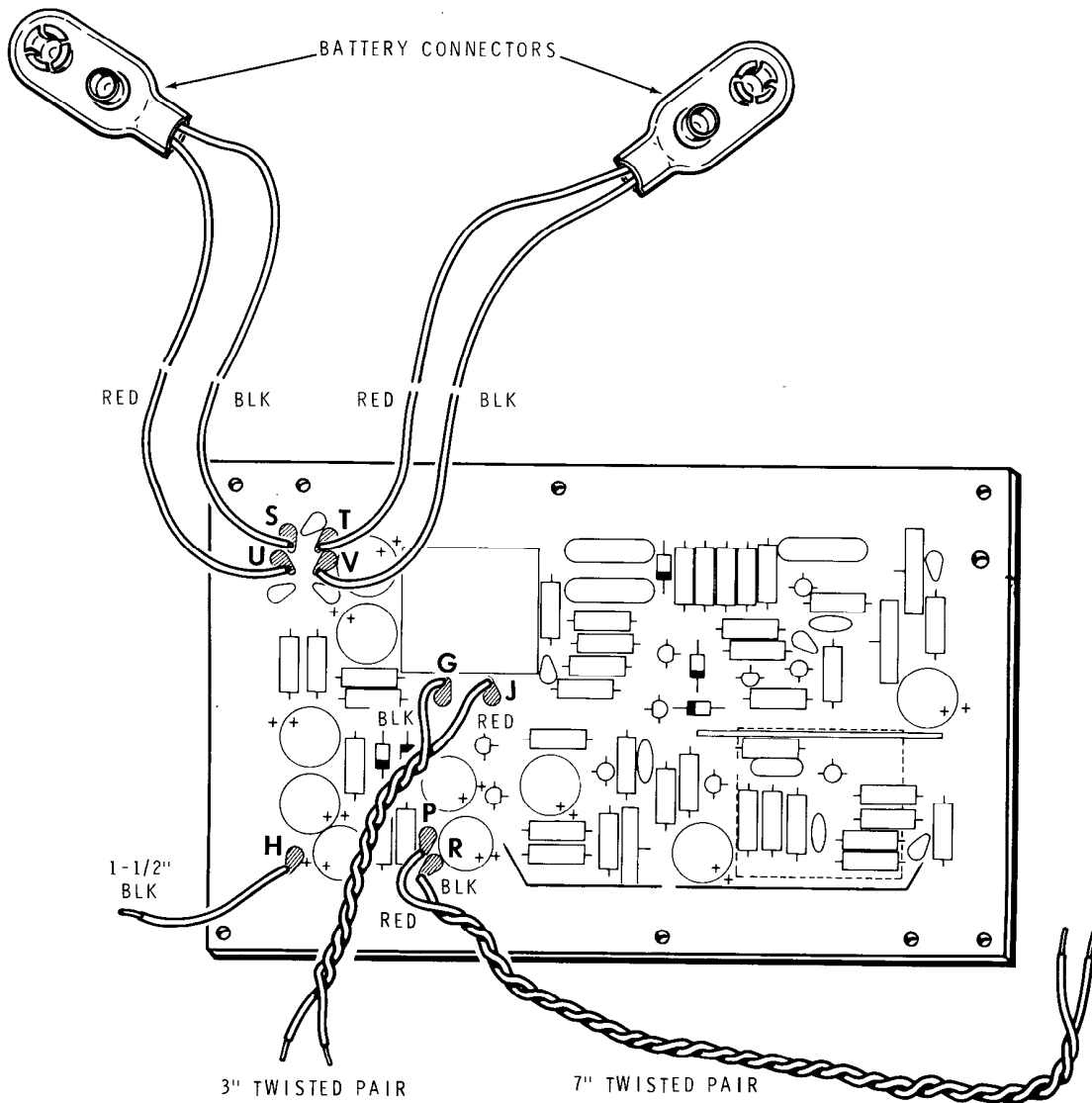

PICTORIAL 1-7

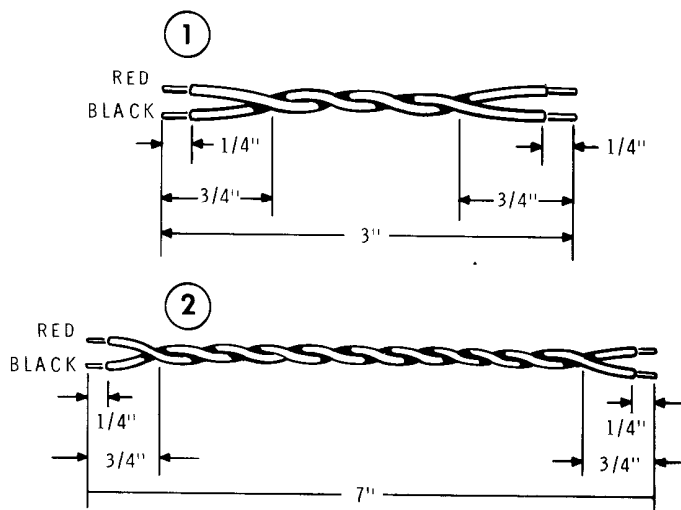

Detail 1-7A

Refer to Pictorial 1-7 for the following steps.

- (✓) Position the circuit board as shown.

As you wire this kit, you will be instructed to prepare wires ahead of time as in the following step. To prepare a wire, cut it to the indicated length and remove 1/4" of insulation from each end. The wires are listed in the order in which they will be used.

- (✓) Prepare a 1-1/2" black wire.

NOTE: In the following steps, "S-" with a number, such as (S-3), means to solder the connection. The number following the "S" tells how many wires are at the connection. (NS) means not to solder because other wires will be added later.

- (✓) Connect one end of the 1-1/2" black wire to circuit board hole H (S-1). You will connect the other end later.

- (✓) Refer to Detail 1-7A Part 1 and twist a red and black wire together to form a 3" twisted pair.
- (✓) Refer to Detail 1-7A Part 2 and twist a red and black wire together to form a 7" twisted pair.
- ( ) Connect the red wire from the 3" twisted pair to circuit board hole J (S-1) and the black wire to hole G (S-1).
- (✓) Connect the red wire from the 7" twisted pair to circuit board hole P (S-1) and the black wire to hole R (S-1).
- (✓) Connect the red lead of one battery connector to circuit board hole U (S-1) and the black lead to hole S (S-1).
- (✓) Connect the red lead of the other battery connector to circuit board hole T (S-1) and the black lead to hole V (S-1).

## CIRCUIT BOARD CHECKOUT

Carefully inspect the circuit board for the following conditions.

- ( ) Unsoldered connections.
- (✓) Poor solder connections.
- (✓) Solder bridges between foils.
- ( ) Protruding leads which could touch together.
- ( ) Transistors for the proper type and installation.
- (+) Electrolytic capacitors for the correct position of the positive (+) end.
- (✓) Diodes for the correct position of the banded end.

This completes the "Circuit Board Assembly"; set it aside temporarily.



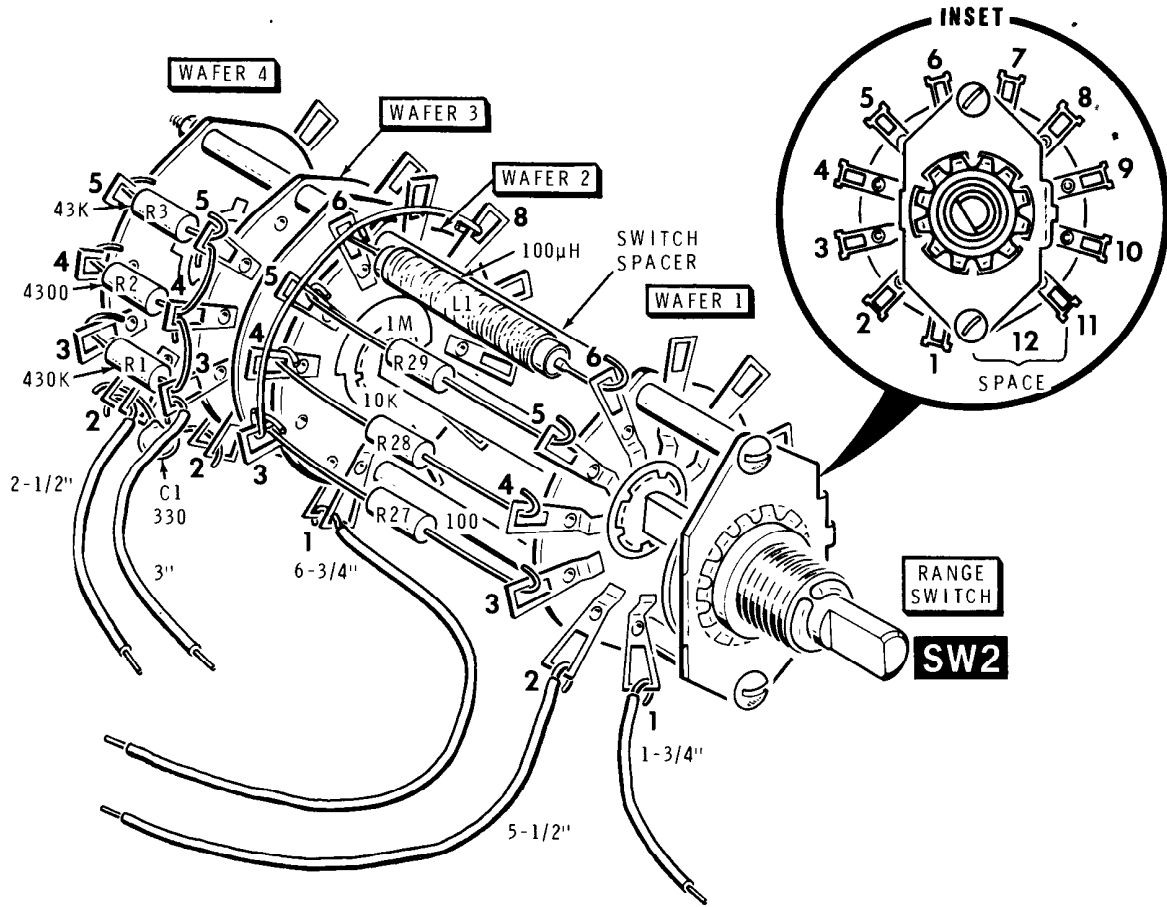

PICTORIAL 2-1

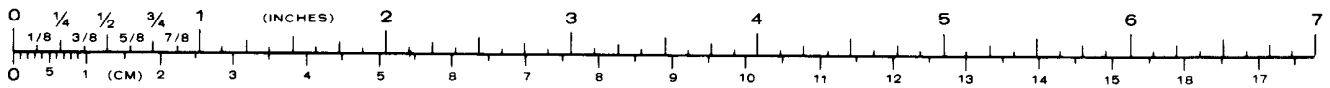



## RANGE SWITCH WIRING

Refer to Pictorial 2-1 for the following steps.

(✓) Prepare the following white wires:

- 1-3/4"
- 5-1/2"
- 6-3/4"
- 3"
- 2-1/2"

(✓) Position switch SW2 with the lugs as shown.

NOTE: The inset drawing of Pictorial 2-1 shows how each lug on the range switch (SW2) is numbered. Each lug location has a number, even when a lug is not mounted at that location on the wafer. Note that lug 12 on wafer 1 is missing.

Connect the prepared wires to switch SW2 as follows:

(✓) 1-3/4" wire to wafer 1 lug 1 (S-1).

(✓) 5-1/2" wire to wafer 1 lug 2 (S-1).

NOTE: When a connection is made to a "double lug," as in the following step, it will be considered one lug in the solder instructions. Then, when you are directed to solder the connection, be sure to solder the wire or lead to both lugs.

(✓) 6-3/4" wire to wafer 2 lug 1 (S-1).

(✓) 3" wire to wafer 3 lug 3 (NS).

(✓) 2-1/2" wire to wafer 4 lug 2 (NS).

(✓) Cut a 2-5/8" green wire and remove all of the insulation.

(✓) Form the 2-5/8" bare wire so it curves around, and touches wafer 2, switch lugs 3 through 8. Then bend the ends of the wire so they enter and wrap around lugs 3 (NS) and 8 (NS). Make sure the wire does not short to the switch spacer.

(✓) R27: Connect one lead of a 100  $\Omega$  (brown-black-brown) resistor to wafer 1 lug 3 (S-1) and the other lead to wafer 2 lug 3 (S-2).

(✓) R28: Connect one lead of a 10 k $\Omega$  (brown-black-orange) resistor to wafer 1 lug 4 (S-1) and the other lead to wafer 2 lug 4 (S-3).

(✓) R29: Connect one lead of a 1 M $\Omega$  (brown-black-green) resistor to wafer 1 lug 5 (S-1) and the other lead to wafer 2 lug 5 (S-3).

(✓) L1: Connect one lead of a 100  $\mu$ H choke (#45-99) to wafer 1 lug 6 (S-1) and the other lead to wafer 2 lug 6 (NS). Do not let the choke body touch the switch spacer.

(✓) C1: Connect one lead of a 330 pF ceramic capacitor to wafer 3 lug 2 (S-1). Connect the other lead to wafer 4 lug 2 (S-2).

NOTE: Where a wire passes through a connection and then goes to another point, as in the next step, it will count as two wires in the solder instructions (S-2), one entering and one leaving the connection.

(✓) R1: Pass one lead of a 430 k $\Omega$  (yellow-orange-yellow) resistor to wafer 3 through lug 3 (S-3) to lug 4 (NS). Connect the other lead to wafer 4 lug 3 (S-1).

(✓) R2: Pass one lead of a 4300  $\Omega$  (yellow-orange-red) resistor to wafer 3 through lug 4 (S-3) to lug 5 (NS). Connect the other lead to wafer 4 lug 4 (S-1).

(✓) R3: Connect one lead of a 43 k $\Omega$  (yellow-orange-orange) resistor to wafer 3 lug 5 (S-2). Connect the other lead to wafer 4 lug 5 (S-1).

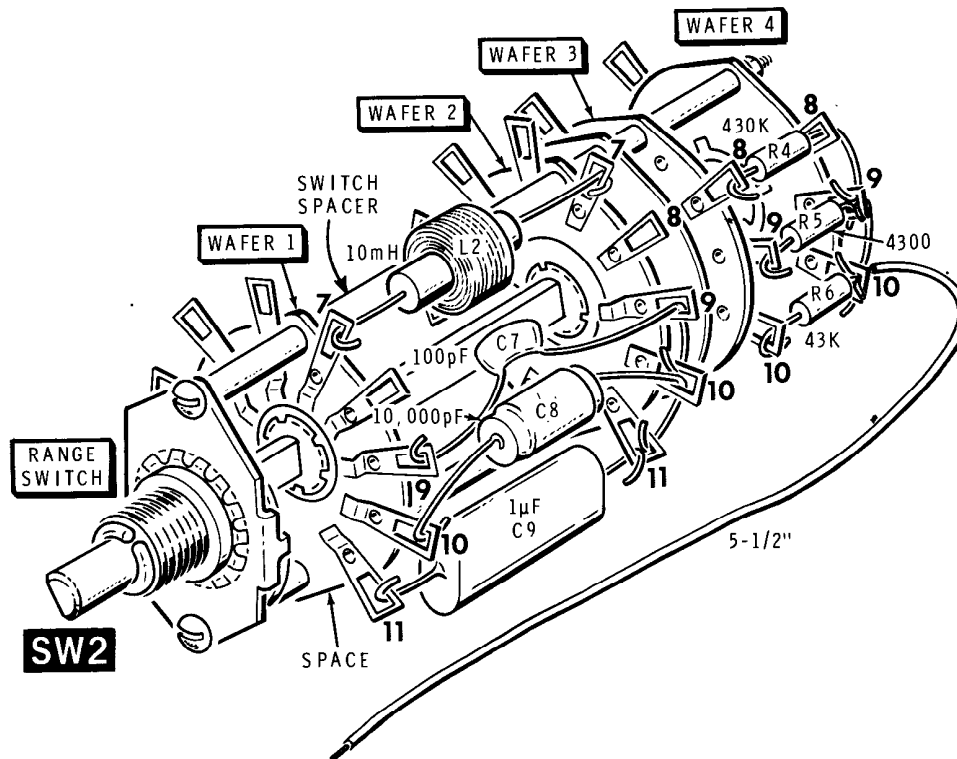

PICTORIAL 2-2

Refer to Pictorial 2-2 for the following steps.

- (✓) Position switch SW2 as shown.
- (✓) Prepare a 5-1/2" white wire.
- (✓) Connect one end of the 5-1/2" white wire to wafer 4 lug 10 (NS).
- (✓) L2: Connect one lead of a 10 mH choke (#45-601) to wafer 1 lug 7 (S-1) and the other lead to wafer 2 lug 7 (S-3). Make sure the choke body does not touch the switch spacer.
- (✓) C7: Connect one lead of a 100 pF mica capacitor to wafer 1 lug 9 (S-1). Pass the other lead to wafer 2 through lug 9 (NS) to lug 10 (NS).
- (✓) C8: Connect either lead of a .01  $\mu$ F (10,000 pF) polystyrene capacitor to wafer 1 lug 10 (S-1). Pass the other lead to wafer 2 through lug 10 (S-3) to lug 11 (NS).
- ( ) C9: Connect either lead of a 1  $\mu$ F Mylar capacitor to wafer 1 lug 11 (S-1). Connect the other lead to wafer 2 lug 11 (S-2).
- (✓) R4: Connect one lead of a 430 k $\Omega$  (yellow-orange-yellow) resistor to wafer 3 lug 8 (S-1). Pass the other lead to wafer 4 through lug 8 (S-2) to lug 9 (NS).
- (✓) R5: Connect one lead of a 4300  $\Omega$  (yellow-orange-red) resistor to wafer 3 lug 9 (S-1). Pass the other lead to wafer 4 through lug 9 (S-3) to lug 10 (NS).
- (✓) R6: Connect one lead of a 43 k $\Omega$  (yellow-orange-orange) resistor to wafer 3 lug 10 (S-1). Connect the other lead to wafer 4 lug 10 (S-3).

Set the range switch aside.



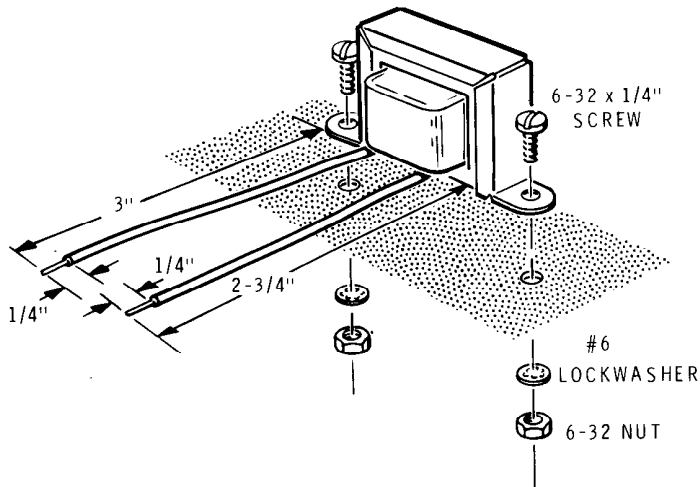

Detail 3-1A

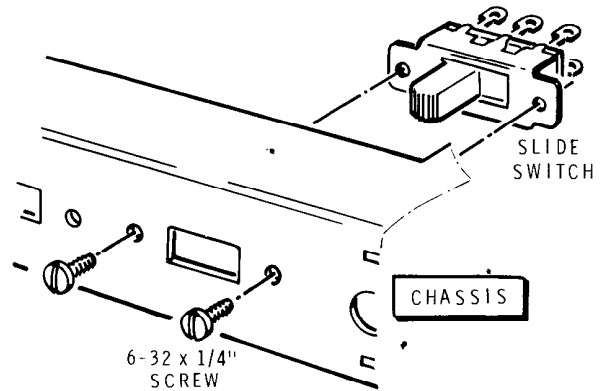

Detail 3-1B

### CHASSIS ASSEMBLY AND WIRING

Refer to Pictorial 3-1 (Illustration Booklet, Page 2) for the following steps.

- (✓) Position the chassis as shown.
- (✓) Mount the circuit board on the chassis with six 6-32 x 1/4" screws; six #6 lockwashers, and six 6-32 nuts. Position the circuit board as shown.
- (✓) Refer to Detail 3-1A and prepare the leads of the 1 H choke (#46-66) as shown.
- (✓) L3: Refer to Detail 3-1A and mount the choke on the chassis at L3 with two 6-32 x 1/4" screws, two #6 lockwashers, and two 6-32 nuts. Position the choke as shown.
- (✓) SW1: Refer to Detail 3-1B and mount the slide switch (#60-71) on the chassis at SW1. Use two 6-32 x 1/4" screws.
- (✓) R24: Refer to Detail 3-1C and mount a 1000 Ω control (#10-1017) on the chassis at R24. Insert the tabs through the slots in the chassis and bend them over as shown. Position the control lugs as shown.

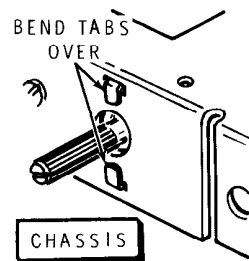
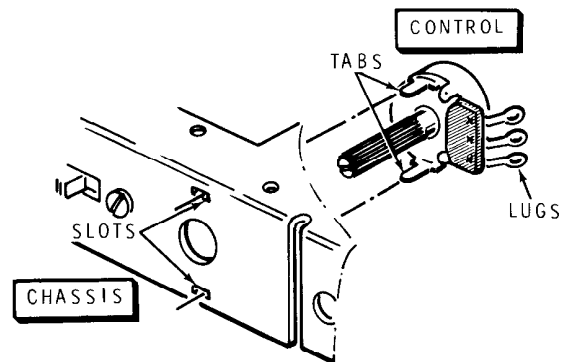

Detail 3-1C

Set the chassis aside temporarily.



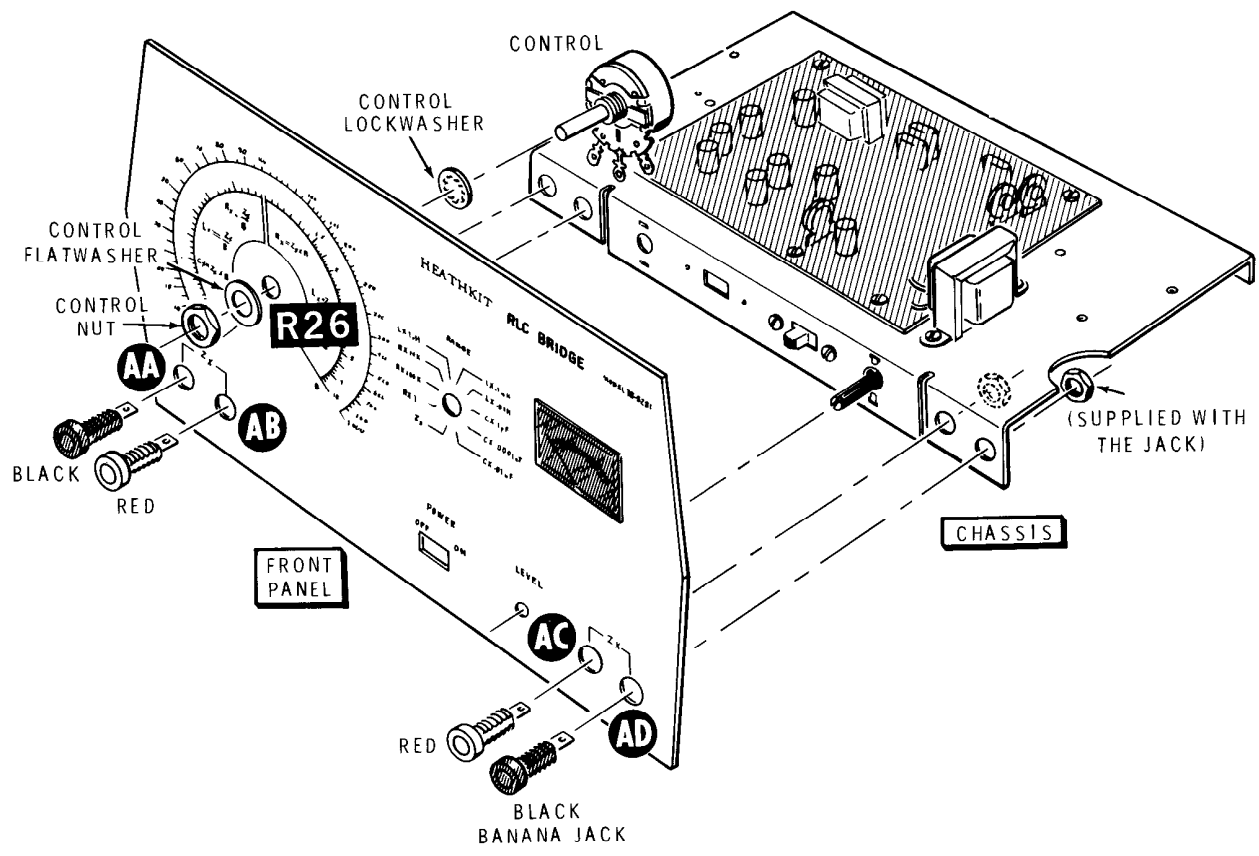

PICTORIAL 3-2

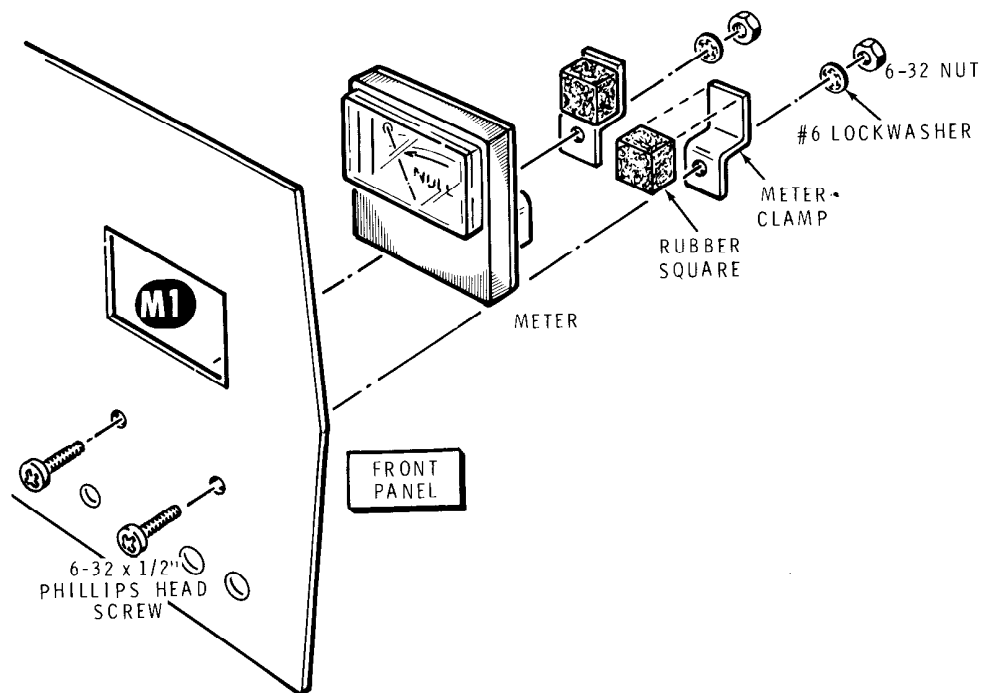

Detail 3-2A

Refer to Pictorial 3-2 for the following steps.

- (✓) Refer to Detail 3-2A and remove the paper backing from a rubber square. Install the rubber square on a meter clamp as shown.
- (✓) In the same manner, install the other rubber square on the remaining meter clamp.
- (✓) M1: Refer to Detail 3-2A and install the meter on the front panel at M1 with two 6-32 × 1/2" phillips-head screws, two #6 lockwashers, and two 6-32 nuts. Remove the shorting wire from the meter lugs if attached. Tighten the nuts securely.

- (✓) Mount the front panel to the chassis. Use the red banana jacks at AB and AC, and the black banana jacks at AA and AD. Use the nuts supplied with the jacks, but do not tighten them yet. Make sure you do not cross-thread the nuts.
- (✓) Position the front panel so the level control shaft and the slide switch operate freely, then tighten the nuts on the banana jacks.
- (✓) R26: Mount the 1000 Ω control (#11-157) on the front panel at R26. Use a control lockwasher, control flat washer, and a control nut. Position the control lugs as shown.

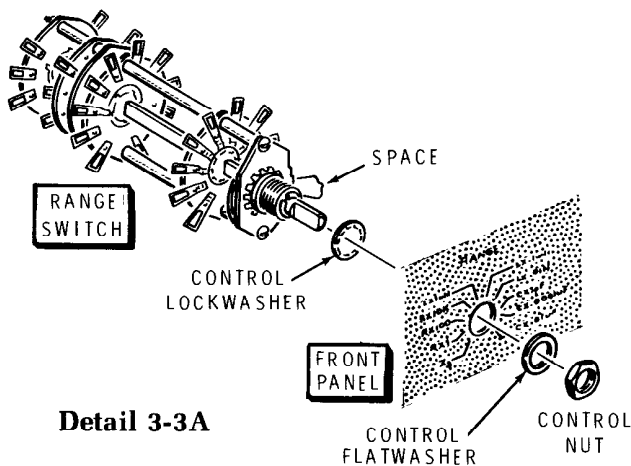

Detail 3-3A

Refer to Pictorial 3-3 (Illustration Booklet, Page 2) for the following steps.

NOTE: Before you perform the following step, route the wires on the circuit board as shown.

- (✓) SW2: Refer to Detail 3-3A and mount the range switch on the front panel at SW2 with a control lockwasher, a control flat washer, and a control nut. Position the switch as shown.

NOTE: As you connect each wire in the following steps, route the wire as shown. After you solder each connection, cut off the excess wire length.

- (✓) Connect the wire coming from wafer 1 lug 1 to circuit board hole N (S-1).
- (✓) Connect the wire coming from wafer 3 lug 3 to circuit board hole C (S-1).
- (✓) Connect the wire coming from wafer 4 lug 2 to circuit board hole B (S-1).
- (✓) Connect the wire coming from wafer 4 lug 10 to circuit board hole A (S-1).
- (✓) Route the wire coming from wafer 1 lug 2 as shown. You will connect it later.
- (✓) Route the wire coming from wafer 2 lug 1 over the top of the Level control in the direction shown. You will connect it later.

Connect the red and black twisted wires coming from circuit board holes P and R as follows:

- (✓) Red wire to meter M1 lug (+) (S-1).

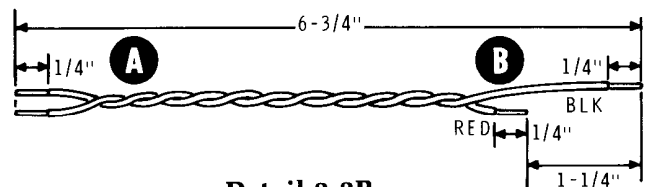

Detail 3-3B

- (✓) Black wire to meter M1 lug (-) (S-1).
- (✓) Connect the black wire coming from circuit board hole H to control R26 lug 2 (S-1).

Connect the red and black twisted wires coming from circuit board holes G and J as follows:

- (✓) Red wire to control R26 lug 1 (NS).
- (✓) Black wire to control R26 lug 3 (NS).
- (✓) Refer to Detail 3-3B and prepare a 6-3/4" red and black twisted pair of wires. Cut a 1-1/4" red wire from either end of the twisted pair.

Connect the 6-3/4" red and black twisted wires as follows:

- (✓) Black wire at end A to control R26 lug 3 (S-2).
- (✓) Red wire at end A to control R26 lug 1 (NS).
- (✓) Black wire at end B to wafer 2 lug 9 (S-3).
- (✓) Short red wire at end B to wafer 2 lug 6 (S-4).
- (✓) Prepare a 4" white wire.
- (✓) Connect one end of the 4" white wire to control R26 lug 1 (S-3). Route the other end as shown. You will connect it later.
- (✓) Connect the 2-3/4" lead of choke L3 to wafer 1 lug 8 (S-1).
- (✓) Connect the 3" lead of choke L3 to wafer 2 lug 8 (S-2).
- (✓) Carefully peel the paper backing from the blue and white label and press the label into place on the inside of the front panel. Make sure you refer to the numbers on the label in any communications you have with the Heath Company about this kit.

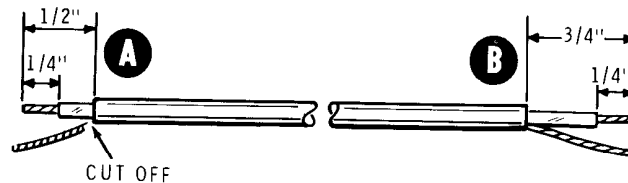

Detail 3-4A

Refer to Pictorial 3-4 (Illustration Booklet, Page 3) for the following steps.

(✓) Position the chassis as shown.

NOTE: When you connect each of the following wires to the foil side of the circuit board, leave the insulation  $1/8$ " away from the foil so solder can flow around the bare wire. See the inset drawing. Then solder the exposed wire to the foil. Cut off the excess wire lengths from the component (lettered) side of the circuit board.

(✓) Connect the free end of the wire coming from wafer 1 lug 2 to the red banana jack at AB (S-1).

(✓) Connect the free end of the wire coming from control R26 lug 1 to the black banana jack at AA (S-1).

(✓) Connect the free end of the wire coming from wafer 2 lug 1 to the black banana jack at AD (S-1).

( ) Prepare the following wires:

- 4-5/8" green
- 4-3/4" red
- 1-7/8" black

Connect the prepared wires as follows:

(✓) 4-5/8" green wire between switch SW1 lug 2 (S-1) and circuit board hole AA (S-1).

(✓) 4-3/4" red wire between switch SW1 lug 5 (S-1) and circuit board hole AB (S-1).

(✓) 1-7/8" black wire between control R24 lug 3 (NS) and circuit board hole L(S-1).

(✓) Refer to Detail 3-4A and prepare one 2-1/2" and two 5-1/2" shielded cables.

(✓) Connect the inner lead at end A of the 2-1/2" shielded cable to the red banana jack at AC (S-1). Connect the inner lead at end B to circuit board hole K (S-1) and the shield lead to hole E (S-1).

(✓) Connect the inner lead at end B of a 5-1/2" shielded cable to control R24 lug 1 (S-1) and the shield lead to lug 3 (NS). Connect the inner lead at end A to circuit board hole D (S-1).

(✓) Connect the inner lead at end B of the other 5-1/2" shielded cable to control R24 lug 2 (S-1) and the shield lead to lug 3 (S-3). Connect the inner lead at end A to circuit board hole F (S-1).

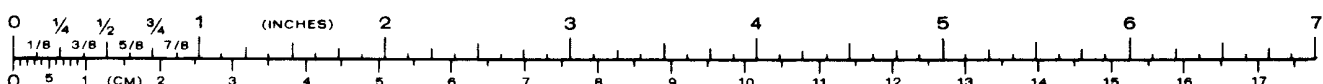

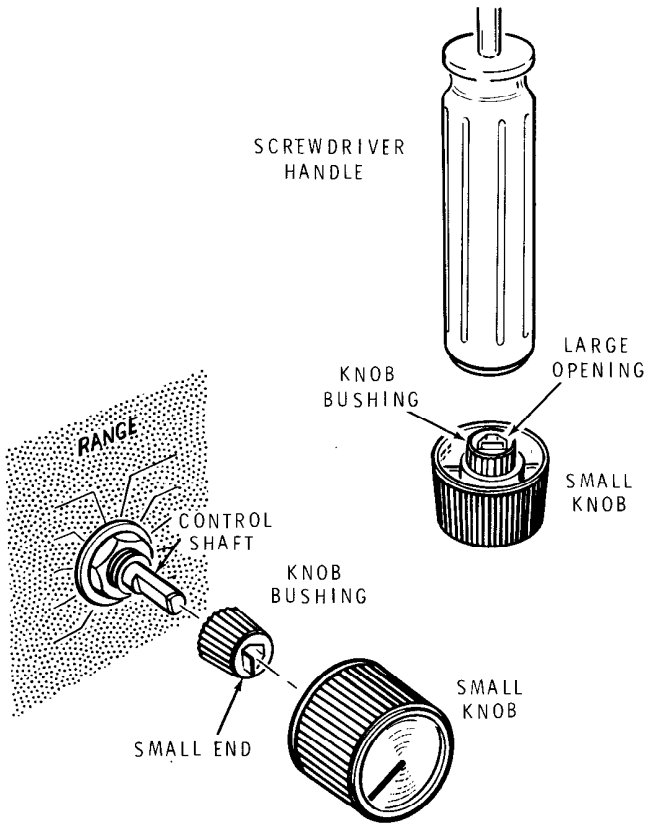

**Detail 3-5A**

Refer to Pictorial 3-5 (Illustration Booklet, Page 3) for the following steps.

- (✓) Position the chassis as shown.
- (✓) Refer to Detail 3-5A and install a knob bushing on switch shaft SW2. Position the small end of the bushing as shown.
- (✓) Rotate the shaft of switch SW2 completely counterclockwise.

Refer to Detail 3-5A and install a small knob on the knob bushing in the following manner:

- (✓) Line up the knob indicator with the Z<sub>s</sub> mark on the front panel.
- (✓) Push the knob part way onto the bushing.
- (✓) Now carefully remove both the bushing and the knob. Do not allow the knob to come off the bushing.

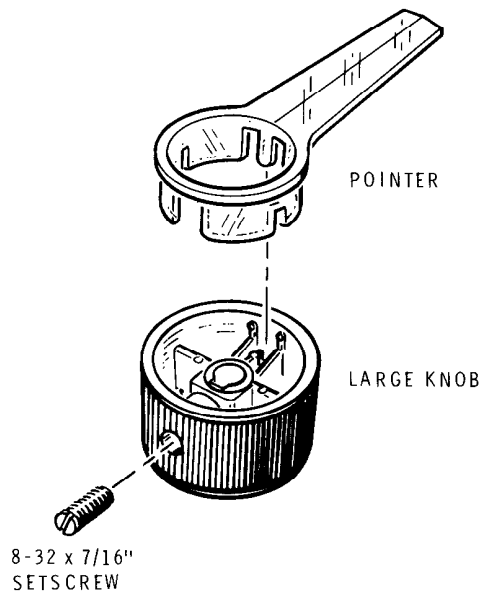

**Detail 3-5B**

- (✓) Place the knob on a table or other firm surface. Place a soft cloth under the knob to prevent it from being marred. Then use a nutdriver or a large screwdriver and drive the bushing into the knob.
- (✓) Replace the knob on the switch shaft at SW2.
- (✓) Refer to Detail 3-5B and insert the dial pointer (#463-28) on the large knob as shown. Install an 8-32 x 7/16" setscrew in the knob.
- (✓) Turn control R26 fully counterclockwise and install the large knob with the pointer on the control shaft.
- (✓) Position the pointer at the approximate position shown and tighten the setscrew until it is just snug.

This completes the "Chassis Assembly and Wiring." If you intend to use the Power Supply with your RLC Bridge, proceed to "Power Switch and Connector Wiring." If you did not purchase the power supply and intend to use batteries **only**, disregard the following steps and proceed to "Battery Only Wiring" on Page 28. NOTE: You will need the leftover black, red, and green wires to modify your unit if you purchase the AC Power Supply later.

You will have a 100 Ω (brown-black-brown) resistor left over at this time. Save it for "Calibration."

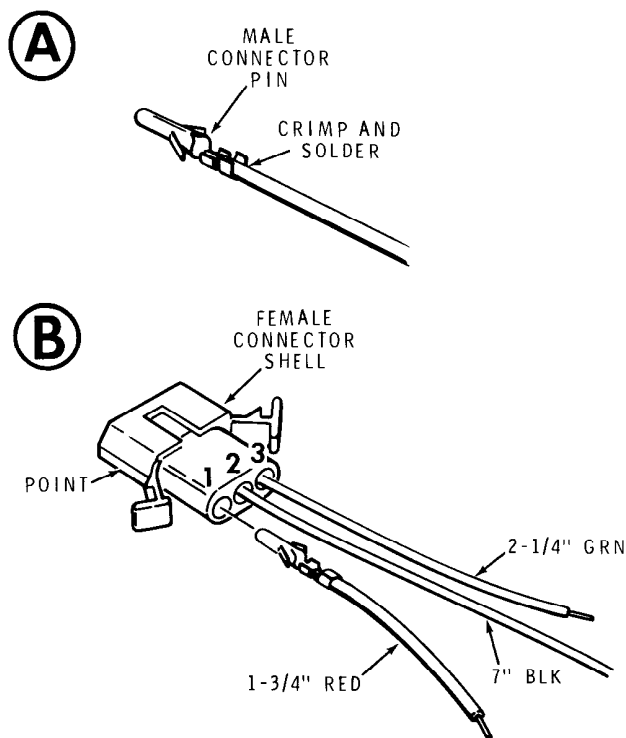

Detail 3-6A

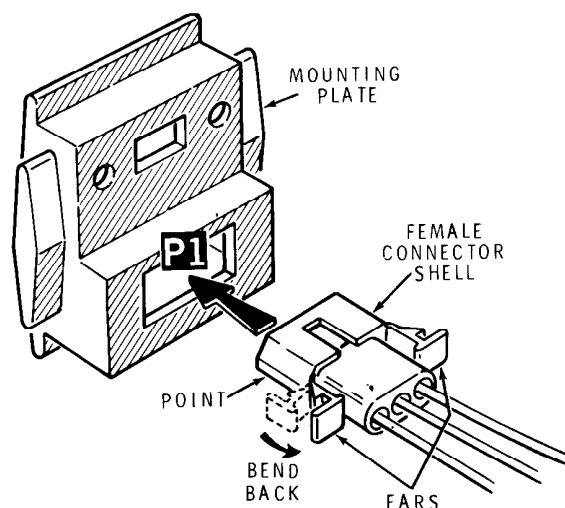

Detail 3-6B

Refer to Detail 3-6A Part A and install a male connector pin on each of the following wires:

- ( ) 1-3/4" red (S-1).
- ( ) 7" black (S-1).
- ( ) 2-1/4" green (S-1).

Refer to Detail 3-6A Part B and position the connector shell with ears with the point as shown. Push the male connector pins into the holes as follows. Note: The connector pins will "click" as they lock into place.

- ( ) 1-3/4" red wire into hole 1.
- ( ) 7" black wire into hole 2.
- ( ) 2-1/4" green wire into hole 3.
- ( ) P1: Refer to Detail 3-6B and bend the ears of the connector shell back against the side of the body as shown. Position the pointed end as shown. Push the connector shell into the mounting plate hole at P1. The ears of the connector shell will lock into place at the edges of the hole.

## POWER SWITCH AND CONNECTOR WIRING

- ( ) Locate the following parts from your Power Supply parts pack:

- 1 Slide switch (#60-2).
- 1 Mounting plate (#92-669).
- 3 Male connector pins (#432-72).
- 1 Connector shell with ears (#432-720).
- 2 6-32 × 1/4" screw (#250-56).

Refer to Pictorial 3-6 (Illustration Booklet, Page 4) for the following steps.

- ( ) Prepare the following wires:

- 1-3/4" red
- 7" black
- 2-1/4" green



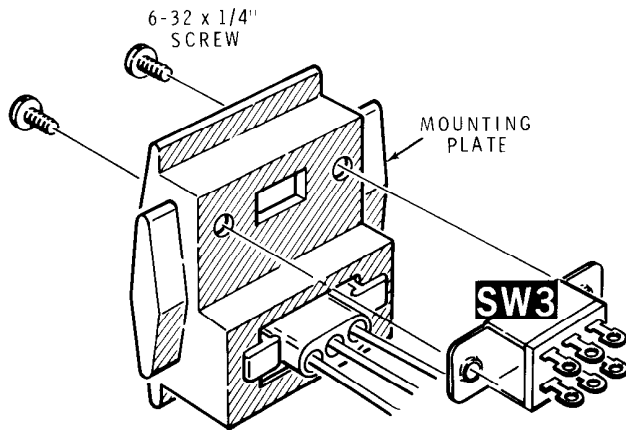

**Detail 3-6C**

- ( ) SW3: Refer to Detail 3-6C and install the slide switch on the mounting plate at SW3 with two 6-32 × 1/4" screws.

Connect the free end of the wires coming from plug P1 as follows:

- ( ) Red wire to switch SW3 lug 6 (S-1).  
 ( ) Black wire to circuit board hole X (S-1).  
 ( ) Green wire to switch SW3 lug 1 (S-1).  
 ( ) Prepare the following wires:

7-1/2" green

7-1/2" red

8-1/2" green

8-1/2" red

- ( ) Connect one end of the 7-1/2" green wire to switch SW3 lug 3 (S-1) and the other end to circuit board hole Y (S-1).  
 ( ) Connect one end of the 7-1/2" red wire to switch SW3 lug 4 (S-1) and the other end to circuit board hole Z (S-1).

- ( ) Connect one end of the 8-1/2" green wire to switch SW3 lug 2 (S-1). Route the free end of this wire through hole F.  
 ( ) Connect one end of the 8-1/2" red wire to switch SW3 lug 5 (S-1). Route the free end of this wire through hole F.  
 ( ) Connect the green wire coming from hole F to switch SW1 lug 3 (S-1).  
 ( ) Connect the red wire coming from hole F to switch SW1 lug 4 (S-1).

NOTE: Lugs 1 and 6 of switch SW1 are not used.

This completes the "Power Switch and Connector Wiring." Proceed to "Initial Test and Adjustments."

### BATTERY ONLY WIRING

Refer to Pictorial 3-7 (Illustration Booklet, Page 4) for the following steps.

- ( ) Prepare an 8-1/2" red and an 8-1/2" green wire.  
 ( ) Connect the 8-1/2" red wire between SW1 lug 4 (S-1) and circuit board hole Z (S-1). Route the end of this wire through hole F.  
 ( ) Connect the 8-1/2" green wire between SW1 lug 3 (S-1) and circuit board hole Y (S-1). Route the end of this wire through hole F.

Proceed to "Initial Test and Adjustments."

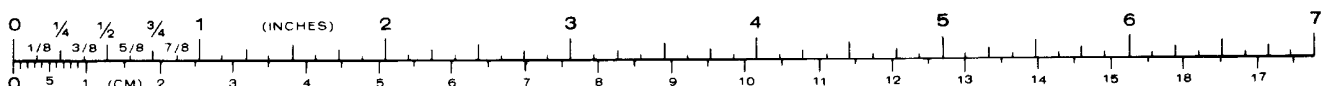

## INITIAL TEST AND ADJUSTMENTS

The purpose of this section of the Manual is to make sure your RLC Bridge operates properly and will not be damaged as a result of a wiring error. A transistor, for example, could be destroyed instantly by a short circuit that causes excessive current.

- (✓) Inspect the Bridge for improperly soldered connections, or connections that may be missed or unsoldered. Also check for solder bridges across two or more circuit board foils, which would cause a short circuit.
- (✓) Examine the chassis mounted parts and make sure they are properly mounted and connected.
- (✓) Make sure no bare wires are touching any components or the chassis.

### RESISTANCE MEASUREMENTS

NOTE: You will need an ohmmeter to make the following resistance measurements. The readings may take a few seconds to reach the indicated settings due to the charging of capacitors in the circuit. If you do not have an ohmmeter, proceed to "Power Supply Connection."

- (✓) Set your ohmmeter to read  $R \times 100$ .
- ( ) Connect the common lead of your ohmmeter to the chassis.

NOTE: The readings in the following steps, are the minimum desired. If the readings you get are significantly less, you must determine the reason (such as a short circuit between the foils caused by a solder bridge) and correct it before you proceed.

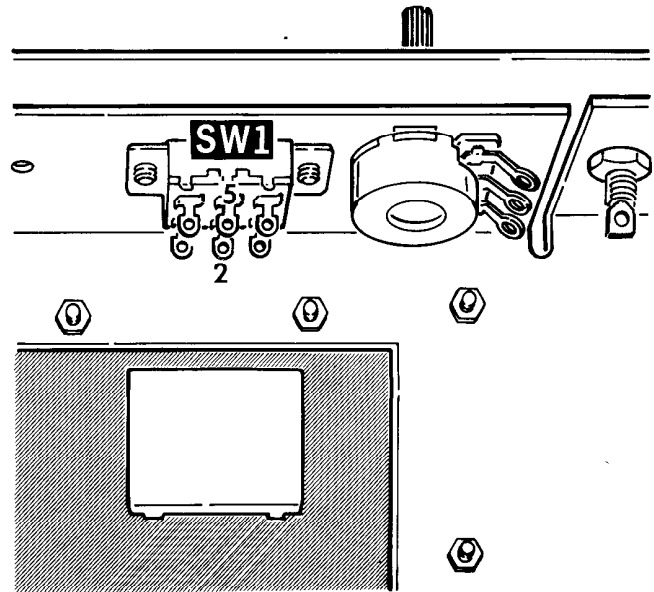

PICTORIAL 4-1

Refer to Pictorial 4-1 for the following steps.

- (✓) Place the POWER switch to ON.
- (✓) Touch the ohmmeter probe to switch SW1 lug 2. The reading should be 5 k $\Omega$  or higher.
- (✓) Touch the ohmmeter probe to switch SW1 lug 5. The reading should be 1 k $\Omega$  or higher.
- (✓) Place the POWER switch to OFF.

Proceed to "Power Supply Connection."

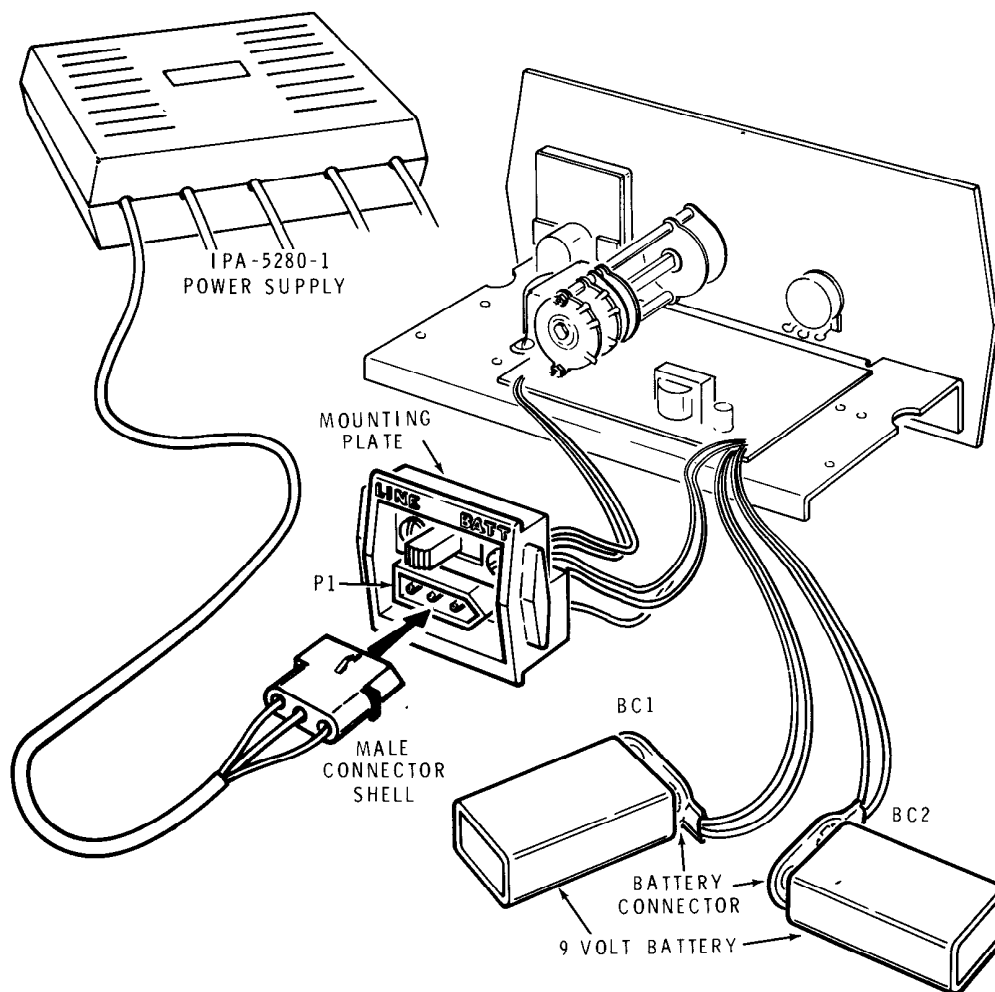

PICTORIAL 4-2

### POWER SUPPLY CONNECTION

Refer to Pictorial 4-2 for the following steps.

- ( ) Position the RLC Bridge as shown.
- ( ) Connect one of the five connector shells coming from the Power Supply to P1 on the mounting plate. Make sure the wire colors at both connectors are the same and are not reversed.
- ( ) Place the LINE/BATT switch to the LINE position.
- ( ) Plug the Power Supply line cord into the appropriate AC receptacle.

NOTE: If you intend to use batteries in addition to the Power Supply, proceed with the following steps. Otherwise, proceed to "Bias Adjustment."

### BATTERY CONNECTION

- ( ) Connect the two 9-volt batteries, which you purchased earlier, to battery connectors BC1 and BC2.
- ( ) If you intend to use batteries at this time, place the LINE/BATT switch to the BATT position.

Proceed to "Bias Adjustment" on Page 31.



## BIAS ADJUSTMENT

Refer to Pictorial 4-3 (Illustration Booklet, Page 5) for the following steps.

(✓) Position the RLC Bridge as shown.

NOTE: Use a small-bladed screwdriver to make the following adjustments. If you do not obtain the proper results during the bias adjustment, refer to "In Case of Difficulty" to help you correct the problem. Do not proceed with any other steps until the problem is corrected.

(✓) Preset controls R9, R14, and R33 to the center of their rotation.

(✓) Place the POWER switch to ON.

NOTE: You will need a voltmeter capable of measuring both AC and DC for the following steps.

(✓) Set the meter to the lowest range capable of measuring 5 volts DC.

(✓) Connect the common lead of your voltmeter to the chassis.

(✓) Touch the voltmeter probe to circuit board point A and adjust control R9 (Bias Adj A) for  $0 \pm .1$  volts. Note: Adjust R9 very slowly and wait for the reading to stabilize each time you stop. Then adjust the control further if necessary to obtain the correct reading.

(✓) Set your meter to the lowest range capable of measuring 5 volts AC (rms).

(✓) Touch the voltmeter probe at circuit board point A and adjust control R14 (Feedback Adj) for a reading of 3 volts AC.

(✓) Set your meter to the lowest range capable of measuring 5 volts DC.

(✓) Touch the voltmeter probe to the collector (C) of transistor Q8 and adjust control R33 (Bias Adj B) for a reading of 4.5 volts.

(✓) Repeat the steps after the second NOTE:

( ) Place the POWER switch to OFF. Disconnect the voltmeter leads.

This completes the "Bias Adjustment." Proceed to "Dial Calibration."

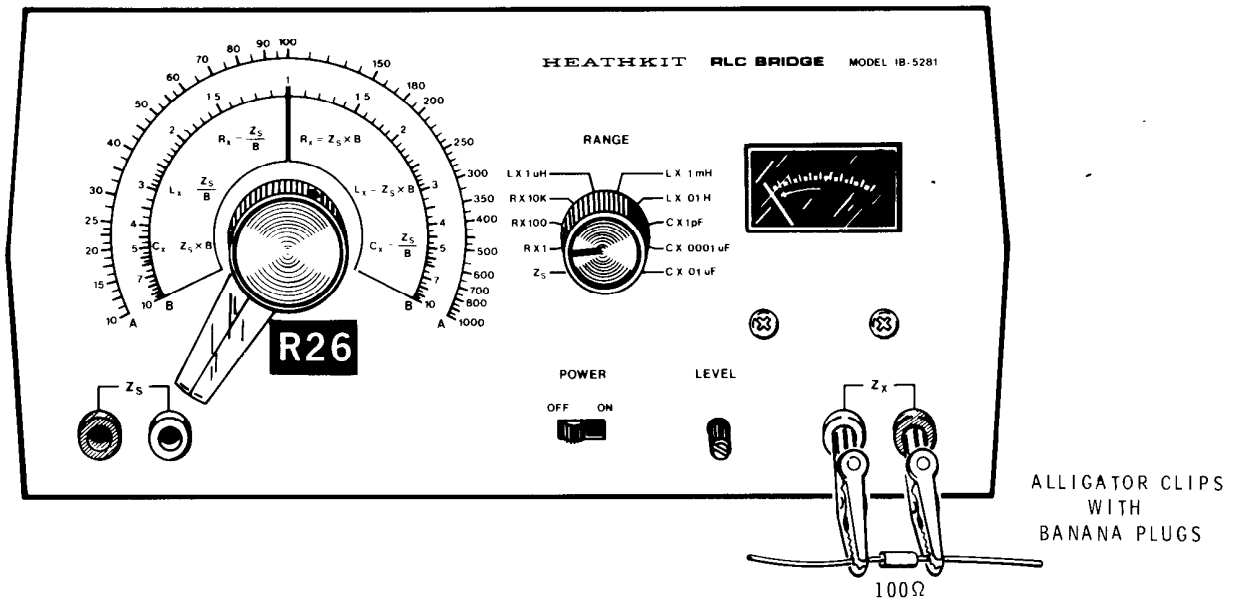

PICTORIAL 4-4

**DIAL CALIBRATION**

Refer to Pictorial 4-4 for the following steps.

Preset the front panel controls as follows:

- (✓) BALANCE control R26 fully counterclockwise.
- (✓) RANGE switch to R×1.
- (✓) LEVEL control fully counterclockwise.
- (✓) Plug both alligator clips into the Z<sub>x</sub> terminals.
- (✓) Locate the 100 Ω (brown-black-brown) resistor which was left over, and install it between the two alligator clips as shown.
- (✓) Place the POWER switch to ON. The meter should swing full scale, then drop back towards 0.
- (✓) Gradually increase the LEVEL control until the meter reads 10.
- (✓) Carefully turn the BALANCE control R26 clockwise. The meter reading should decrease. When the meter reaches a null (lowest reading), stop turning the control.

- (✓) Increase the LEVEL control fully clockwise, rock the BALANCE control back and forth a few times to obtain the best null possible.
- (✓) Very carefully, loosen the setscrew on the balance control knob without moving the control. Position the dial pointer so it is over the 100 mark on the A scale. Tighten the setscrew.
- (✓) Check the null on the meter and make sure the pointer is directly over the “100” mark. If it is not, repeat the previous step.
- (✓) Turn the LEVEL control fully counterclockwise.
- ( ) Return the POWER switch to OFF.
- (✓) Disconnect the 100 Ω resistor and remove the alligator clips from the front panel terminals. Note: Save the resistor in case you would like to recalibrate your unit later.
- ( ) Remove the plug from the AC receptacle. If you are using the Power Supply, disconnect it from the Bridge.

This completes the “Dial Calibration.” Proceed to “Final Assembly.”

## FINAL ASSEMBLY

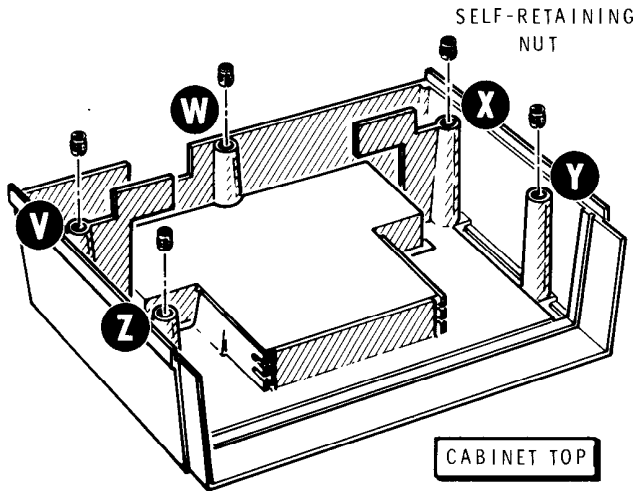

PICTORIAL 5-1

Refer to Pictorial 5-1 for the following steps.

- (✓) Position the cabinet top as shown.
- (✓) Install five self-retaining nuts at V, W, X, Y, and Z. Insert the slotted end of each nut into the cabinet post and press the nut into the hole. Use a screwdriver handle to drive the nut down into the hole. Set the cabinet top aside temporarily.

Refer to Pictorial 5-2 (Illustration Booklet, Page 6) for the following steps.

- (✓) Position the cabinet bottom as shown.
- (✓) Refer to Detail 5-2A and cut a 2" piece of double-stick foam tape in half. Then remove the paper backing from one side of both halves.
- (✓) Press the double-stick foam tape into battery compartments BC1 and BC2.
- (✓) In a like manner, prepare the remaining 2" piece of foam tape and install the tape in battery compartments BC3 and BC4.

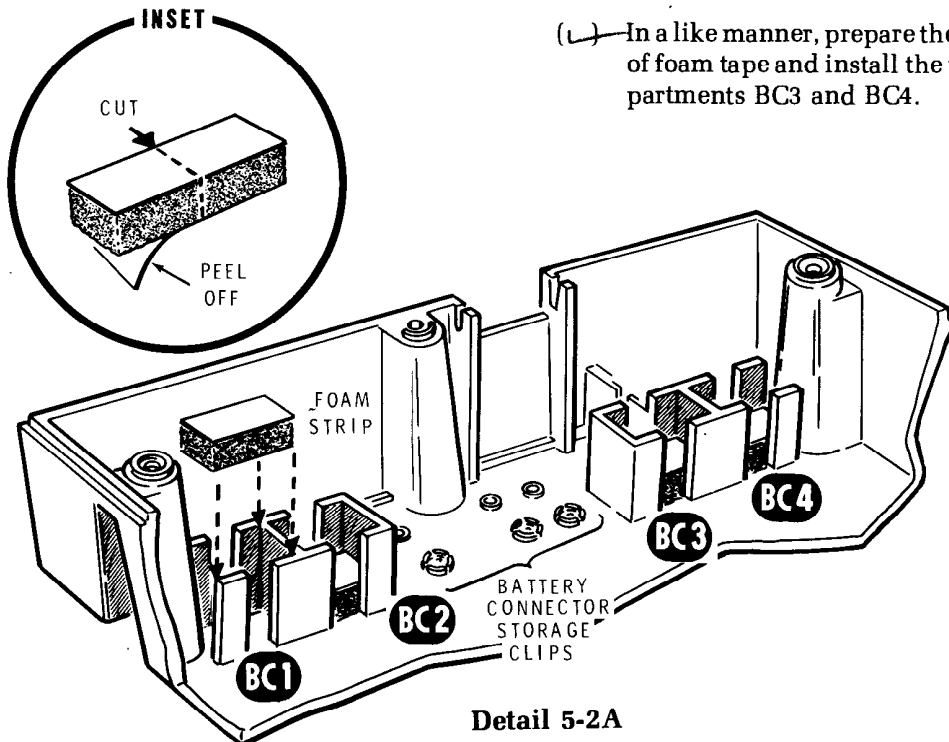

Detail 5-2A

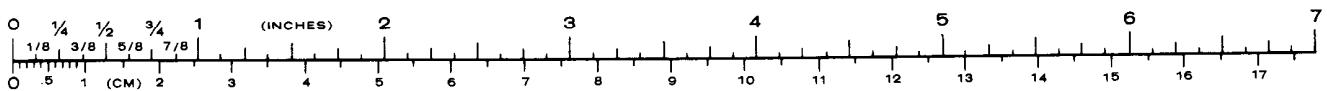

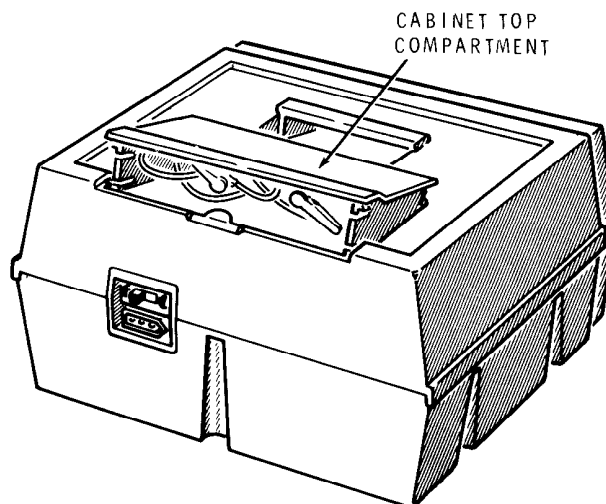

**Detail 5-2C**

- ( ) Refer to Detail 5-2B (Illustration Booklet, Page 6) and mount the RLC Bridge in the cabinet bottom at F and G with two 6-32  $\times$  3/8" self-tapping screws. If you use batteries with the RLC Bridge, install them in compartments BC1 and BC2 as shown. Note: You may store spare batteries in compartments BC3 and BC4. If you do not use batteries, press the battery connectors onto the battery connector storage clips in the cabinet bottom.
- ( ) Install either mounting plate at the rear opening of the cabinet bottom as shown in the inset drawing.
- ( ) Install the cabinet top on the cabinet bottom. Make sure the front panel slides into the cabinet groove properly.
- ( ) Install five 6-32  $\times$  1/2" screws through the cabinet bottom. Tighten the screws securely but do not overtighten them.

NOTE: Refer to Detail 5-2C for storage of any cables or accessories for your Bridge in the cabinet top compartment.

This completes the "Final Assembly." Proceed to "Operation."





## OPERATION

This RLC Bridge is a conventional bridge circuit powered by a 1 kHz, 10 kHz, or 100 kHz oscillator. It has a resistance range of 10 ohms to 10 megohms, an inductance range of 10  $\mu$ H to 10 H, and a capacitance range of 10 pF to 10  $\mu$ F. An external standard range increases the versatility of this Bridge for the experimenter.

Refer to Pictorial 6-1 (Illustration Booklet, Page 7) for a brief description of the controls, meter, and terminals.

**NOTE:** It is always best to connect the component under test directly to the  $Z_x$  terminals. Long leads may pick up stray AC fields and give inaccurate readings. If you use test leads, keep them as short as possible.

### USING THE BRIDGE

**NOTE:** The following procedure uses a resistance measurement as an example. Inductance or capacitance measurements are made with the same procedure. Make sure you change the RANGE switch to the appropriate setting when you measure different types of components. Refer to Pictorial 6-1 (Illustration Booklet, Page 7) for a description of the controls.

To test an unknown resistance, perform the following steps.

1. Turn the LEVEL control fully counterclockwise.
2. Turn the RANGE switch knob to the proper "R" multiplier. If you do not know the resistance value, switch to the RX 1 position as a start.
3. Place the POWER switch to ON.
4. Connect the unknown resistance to the  $Z_x$  terminals.
5. Advance the LEVEL control for an approximate full-scale meter reading (10).
6. Adjust the BALANCE control for a null (minimum deflection) on the meter. If you do not obtain a null, switch to the next highest "R" multiplier.
7. Turn the LEVEL control clockwise for an approximate full-scale reading and carefully readjust the BALANCE control for any further null on the meter.
8. Read the resistance, indicated by the dial pointer, on the "A" scale. Multiply the reading by the RANGE switch setting.

### USING AN EXTERNAL STANDARD

The following description gives only one typical example for the external standard function. You may want to use the external standard for other applications. When you use the external standard function, make sure you keep the two component values within a 10:1 ratio; otherwise, you will not obtain a null. A null is the lowest reading obtained on the meter. You will not always obtain a "0" reading when you null your meter.

#### EXAMPLE:

To match several 100  $\Omega$  resistors of an unknown value with a 100  $\Omega$  resistor of a known value to obtain a matched pair, perform the following:

1. Turn the LEVEL control fully counterclockwise.
2. Set the RANGE switch to the  $Z_s$  position.
3. Connect the 100  $\Omega$  resistor of a known value to the  $Z_s$  (external standard) terminals.
4. Place the POWER switch to ON.
5. Connect a 100  $\Omega$  resistor of an unknown value to the  $Z_x$  terminals.
6. Advance the LEVEL control clockwise for an approximate full-scale meter reading.
7. Adjust the BALANCE control and obtain a null on the meter.
8. Turn the LEVEL control clockwise for a full-scale meter reading and carefully readjust the BALANCE control for a null on the meter.



9. Read the resistance, indicated by the dial pointer, on the "B" scale. If the dial pointer indicates "1" (center scale), the resistors are of equal value. If the pointer is to the right or left of center scale, the resistors are not of equal value. To determine the value of the unequal resistor (or any component being tested), use the formulas shown inside the "B" scale. If the pointer is to the left of center scale, use the formulas inside the left scale.

If the pointer is to the right of center scale, use the formulas inside the right scale. It is normal when you measure extreme values, to have the null occur at a much higher point on the null meter.

NOTE: If you use batteries with your RLC Bridge, measure them with a voltmeter occasionally to make sure they are 7 volts or higher. This will insure the best operation for your bridge.

## IN CASE OF DIFFICULTY

This part of the Manual provides you with information that will help you locate and correct difficulties which may occur in your RLC Bridge. This information is divided into two sections. The first section, "General," contains suggestions of a general nature in the following areas:

- Visual check and inspection.
- Precautions to observe when bench testing.

The second section contains a "Troubleshooting Chart" that has a series of "Conditions" and "Possible Causes." Start your troubleshooting procedure by first reading the following "General" section. Then proceed to the appropriate "Condition" and "Possible Cause."

### GENERAL

#### Visual Checks

1. About 90% of the kits that are returned for repair do not function properly due to poor soldering. Therefore, you can eliminate many troubles by a careful inspection of connections to make sure they are soldered as described in the "Soldering" section of the "Assembly Notes." Re-heat any doubtful connections and be sure all the wires are soldered at places where several wires are connected. Check carefully for solder bridges between circuit board foils.

2. Check to be sure that all transistors are in their proper locations, and are installed correctly.
3. Check the value of each part. Be sure that the proper part has been wired into the circuit, as shown in the Pictorial diagrams and is called out in the wiring instructions. It would be easy, for example, to install a 200  $\Omega$  (red-black-brown) resistor in a step that calls for a 1000  $\Omega$  (brown-black-red) resistor.
4. Recheck the wiring. Trace each lead in colored pencil on the Pictorial as you check it. It is frequently helpful to have a friend check your work. Someone who is not familiar with the unit may notice something you have consistently overlooked.
5. Check all component leads connected to the circuit board. Make sure the leads do not extend too far through the circuit board and make contact with other connections or parts.
6. Check all of the wires that are connected to the circuit board or switches to be sure the wires do not touch each other or other lugs. Make sure all wires are properly soldered.
7. If the difficulty still is not cured, read the "Precautions for Bench Testing," then refer to the "Troubleshooting Chart."



## Precautions for Bench Testing

- Test transistors carefully. Although they have almost unlimited life when used properly, they are much more vulnerable to damage from excessive voltage and current than other circuit components.
- Be careful you do not short any test points to ground when you make voltage measurements. If the probe slips, for example, and shorts out a bias or voltage supply point, it may damage one or more components.

Do not remove any components from the circuit board while the RLC Bridge is turned on.

When you make repairs to the RLC Bridge, make sure you eliminate the cause as well as the effect of the trouble. If, for example, you find a damaged resistor, make sure you find out what (wiring error, etc.) caused the resistor to become damaged. If the cause is not eliminated, the replacement resistor may become damaged when the Bridge is put back into operation.

Refer to the "X-Ray Views," "Identification Charts," and the "Schematic Diagram" to locate the various components.

Use a high impedance voltmeter to make the specified measurements in this section.

In an extreme case where you are unable to resolve a difficulty, refer to the "Customer Service" information inside the rear cover of the Manual. Your warranty is located inside the front cover.

## TROUBLESHOOTING CHART

This chart lists the "Condition" and "Possible Cause" of several malfunctions. If a particular part or parts are mentioned (Q1 for example) as a possible cause,

check that part to see if it was installed and/or wired correctly. It is also possible, on rare occasions, for a part to be faulty and require replacement.

CONDITION	POSSIBLE CAUSE
No DC voltage change at point A when R9 is adjusted.	<ol style="list-style-type: none"> <li>1. C3 is shorted.</li> <li>2. Range switch miswired or loose connection.</li> <li>3. R9 defective.</li> <li>4. Q1 through Q5 installed incorrectly or shorted.</li> <li>5. D1, D2 installed backwards.</li> </ol>
No AC voltage at point A.	<ol style="list-style-type: none"> <li>1. C1 through C6 interchanged.</li> <li>2. C1 open.</li> <li>3. Open range switch.</li> </ol>
No DC bias voltage change at the collector of Q8 when R33 is adjusted.	<ol style="list-style-type: none"> <li>1. Q6 through Q10 installed incorrectly or shorted.</li> <li>2. C13, C17, shorted.</li> </ol>
No meter indication.	<ol style="list-style-type: none"> <li>1. Q6 through Q10 installed incorrectly or shorted.</li> <li>2. Range switch miswired or has loose connection.</li> <li>3. Open meter.</li> <li>4. Weak batteries.</li> </ol>
Meter gives reverse indication.	<ol style="list-style-type: none"> <li>1. D4, D5 installed backwards.</li> <li>2. Wires to meter reversed.</li> </ol>
Balance control is ineffective. Null occurs off scale.	<ol style="list-style-type: none"> <li>1. T1 open.</li> <li>2. Balance control miswired.</li> <li>3. Component out of range of scale, or <math>Z_s</math> and <math>Z_x</math> ratio too wide.</li> </ol>
Level control is inoperative.	<ol style="list-style-type: none"> <li>1. Level control miswired.</li> <li>2. T1 open.</li> </ol>



## SPECIFICATIONS

Resistance Ranges .....	10 $\Omega$ to 10 M $\Omega$ in three ranges.
Inductance Ranges .....	10 $\mu$ H to 10 H in three ranges.
Capacitance Ranges .....	10 pF to 10 $\mu$ F in three ranges.
Oscillator Frequencies .....	1 kHz, 10 kHz, 100 kHz.
External Standard Range .....	1:1 to 10:1
Power Supply .....	(2) 9-volt batteries, and/or Heathkit Model IPA-5280-1 Power Supply.
Cabinet Dimensions .....	11" wide $\times$ 5-3/4" high $\times$ 7-3/4" deep (27.9 $\times$ 14.6 $\times$ 19.7 cm).
Net Weight .....	3-1/2 lbs. (1.6 kg).

---

The Heath Company reserves the right to discontinue products and to change specifications at any time without incurring any obligation to incorporate new features in products previously sold.

## CIRCUIT DESCRIPTION

Refer to the Block Diagram (Illustration Booklet, Page 8) and Schematic Diagram (fold-in) as you read the "Circuit Description."

Part 1 of Pictorial 7-1 shows the configuration for a Wheatstone Bridge. When all the values of R are equal, the voltage at point A will equal the voltage at point B and the meter will indicate "0" (no current flow) or a "balanced bridge."

Assume that R3 is an unknown value. If the bridge becomes unbalanced, the voltages at points A and B become unequal, and the meter deflects and indicates the difference voltage. By adjusting R1 to give a balanced bridge condition, you will now know the value of R3, since it is equal to R1. R1 is usually a calibrated control or a step-type variable resistor for convenience of adjustment and readout.

Part 2 of Pictorial 7-1 shows the configuration for the RLC Bridge. It is basically the same as that of the Wheatstone Bridge. A fixed, internal component standard ( $Z_s$ ) rather than a calibrated potentiometer (as used in the Wheatstone Bridge), is used in conjunction with the Range switch, SW2. The Range switch selects the multiplication factor and a certain frequency for the type of component being tested. The variable function is provided by a single control, which is divided to act as two arms of the bridge, at R1 and R2. Changing both of these values on the bridge provides a much greater range than a single control would provide.

When you test an unknown component value ( $Z_x$ ), the known component ( $Z_s$ ) must be the same type as the unknown component ( $Z_x$ ). The balance control at R1 and R2 is actually matching the ratio of the unknown component to the known standard. The range switch is marked in R, L, and C values to simplify the read-out.

The RLC Bridge circuit uses an AC source rather than a DC type since capacitors and inductors cannot be tested with DC. The AC required to operate the bridge is generated by a Wien bridge oscillator. This oscillator consists of transistors Q1 through Q5. It provides a low impedance output to drive bridge transformer T1. Level control R24 adjusts the oscillator output level to keep meter M1 on scale. The oscillator output voltage is rectified by diode D3 and is used as a control voltage at the gate of transistor Q2. Q2 acts as a variable source resistance for transistor Q1 and controls its gain. The oscillator provides three output frequencies, which are selected by the Range switch for the particular type of component being tested. The frequency used for each range is as follows:

RANGE	FREQUENCY
$Z_s$ (external standard)	1000Hz
R×1	1000 Hz
R×100	1000 Hz
R×10k	1000 Hz
L×1 $\mu$ H	100 kHz
L×.1 mH	10 kHz
L×.01 H	1000 Hz
C×1 pF	100 kHz
C×F .0001 $\mu$ F	10 kHz
C×.01 $\mu$ F	1000 Hz

### PART 1

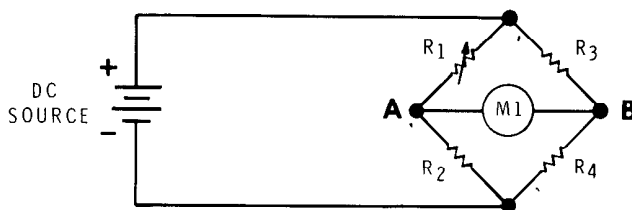

### PART 2

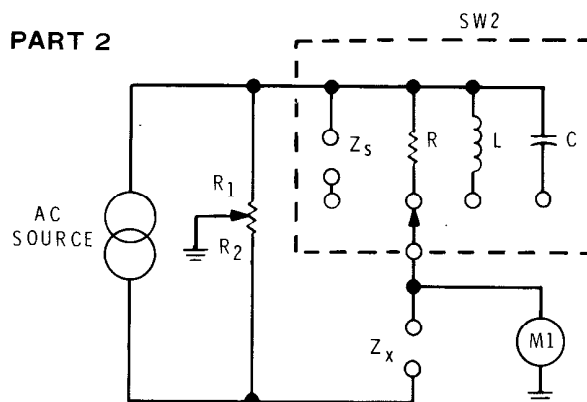

PICTORIAL 7-1

Meter M1, which indicates a null (or balanced bridge condition), is powered by amplifier stages Q6 through Q10. DC feedback is provided via R31 while AC feedback is provided through the meter circuit via capacitors C14 and C15. Both types of feedback enhance circuit stabilization.

Power is supplied by two 9-volt batteries (see "Introduction" for the type) and/or the Heath Model IPA-5280-1 Power Supply.

## CIRCUIT BOARD X-RAY VIEW

NOTE: To find the PART NUMBER of a component for the purpose of ordering a replacement part:

- A. Find the circuit component number (R5, C3, etc.) on the X-Ray View.
- B. Locate this same number in the "Circuit

Component Number" column of the "Parts List" in the front of this Manual.

- C. Adjacent to the circuit component number, you will find the PART NUMBER and DESCRIPTION which must be supplied when you order a replacement part.

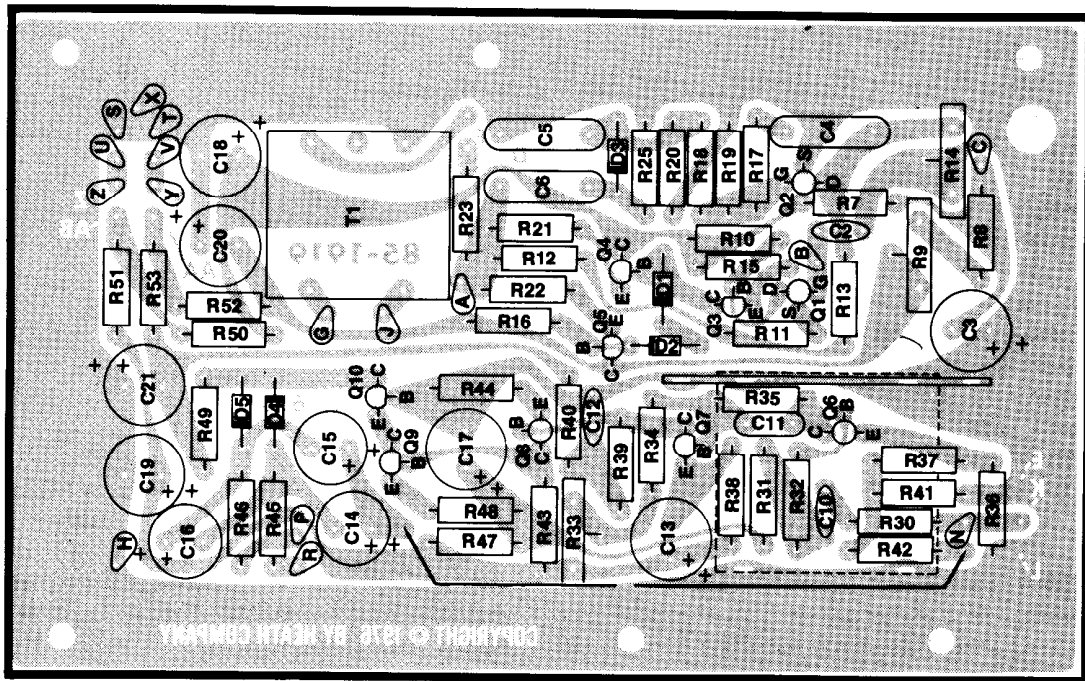

VIEWED FROM COMPONENT SIDE

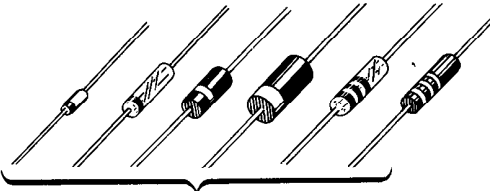
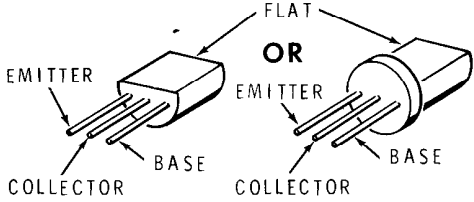
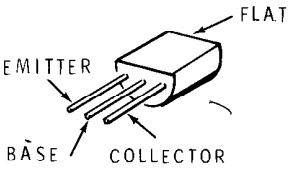
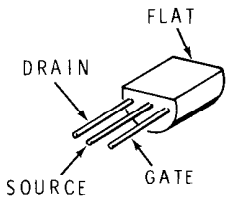

## SEMICONDUCTOR IDENTIFICATION CHART

SCHEMATIC NUMBER	HEATH PART NUMBER	MANUFACTURER'S NUMBER	LEAD IDENTIFICATION
D1, D2, D3	56-56	1N4149	<p><b>IMPORTANT: THE BANDED END OF DIODES CAN BE MARKED IN A NUMBER OF WAYS.</b></p>  <p style="text-align: center;"><b>BANDED END</b></p>
D4, D5	56-89	GD510	
Q6, Q8	417-94	2N3416	
Q4	417-801	MPSA20	
Q3, Q5, Q7, Q9, Q10	417-235	2N4121	
Q1, Q2	417-291	2N5458	

**FOR PARTS REQUESTS ONLY**

- Be sure to follow instructions carefully.
- Use a separate letter for all correspondence.
- Please allow 10 - 14 days for mail delivery time.

**DO NOT WRITE IN THIS SPACE**

**INSTRUCTIONS**

- Please print all information requested.
- Be sure you list the correct **HEATH** part number exactly as it appears in the parts list.
- If you wish to prepay your order, mail this card and your payment in an envelope. Be sure to include 10% (25¢ minimum, \$3.50 maximum) for insurance, shipping and handling. Michigan residents add 4% tax.  
Total enclosed \$ \_\_\_\_\_
- If you prefer COD shipment, check the COD box and mail this card. COD

NAME \_\_\_\_\_  
 ADDRESS \_\_\_\_\_  
 CITY \_\_\_\_\_  
 STATE \_\_\_\_\_ ZIP \_\_\_\_\_

The information requested in the next two lines is not required when purchasing nonwarranty replacement parts, but it can help us provide you with better products in the future.

Model # \_\_\_\_\_ Invoice # \_\_\_\_\_  
 Date Purchased \_\_\_\_\_ Location Purchased \_\_\_\_\_

LIST HEATH PART NUMBER	QTY.	PRICE EACH	TOTAL PRICE

TOTAL FOR PARTS	
HANDLING AND SHIPPING	
MICHIGAN RESIDENTS ADD 4% TAX	
<b>TOTAL AMOUNT OF ORDER</b>	

SEND TO: **HEATH COMPANY**  
 BENTON HARBOR  
 MICHIGAN 49022  
**ATTN: PARTS REPLACEMENT**

Phone (Replacement parts only): 616 982-3571

**FOR PARTS REQUESTS ONLY**

- Be sure to follow instructions carefully.
- Use a separate letter for all correspondence.
- Please allow 10 - 14 days for mail delivery time.

**DO NOT WRITE IN THIS SPACE**

**INSTRUCTIONS**

- Please print all information requested.
- Be sure you list the correct **HEATH** part number exactly as it appears in the parts list.
- If you wish to prepay your order, mail this card and your payment in an envelope. Be sure to include 10% (25¢ minimum, \$3.50 maximum) for insurance, shipping and handling. Michigan residents add 4% tax.  
Total enclosed \$ \_\_\_\_\_
- If you prefer COD shipment, check the COD box and mail this card. COD

NAME \_\_\_\_\_  
 ADDRESS \_\_\_\_\_  
 CITY \_\_\_\_\_  
 STATE \_\_\_\_\_ ZIP \_\_\_\_\_

The information requested in the next two lines is not required when purchasing nonwarranty replacement parts, but it can help us provide you with better products in the future.

Model # \_\_\_\_\_ Invoice # \_\_\_\_\_  
 Date Purchased \_\_\_\_\_ Location Purchased \_\_\_\_\_

LIST HEATH PART NUMBER	QTY.	PRICE EACH	TOTAL PRICE

TOTAL FOR PARTS	
HANDLING AND SHIPPING	
MICHIGAN RESIDENTS ADD 4% TAX	
<b>TOTAL AMOUNT OF ORDER</b>	

SEND TO: **HEATH COMPANY**  
 BENTON HARBOR  
 MICHIGAN 49022  
**ATTN: PARTS REPLACEMENT**

Phone (Replacement parts only): 616 982-3571

CUT ALONG DOTTED LINE



# ILLUSTRATION

## PARTS PICT

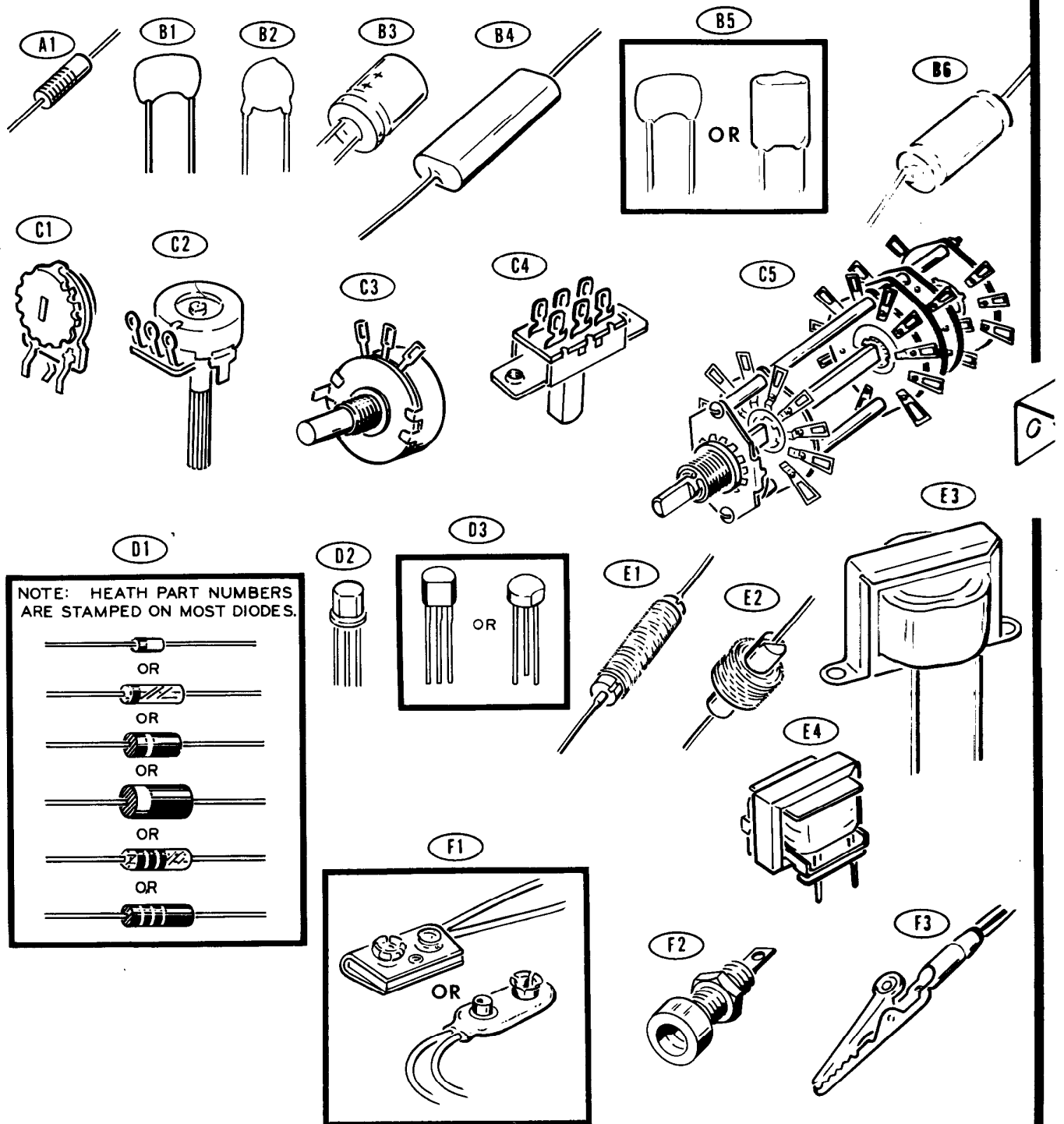

# ION BOOKLET

Part of 595-1958-03

## PICTORIAL

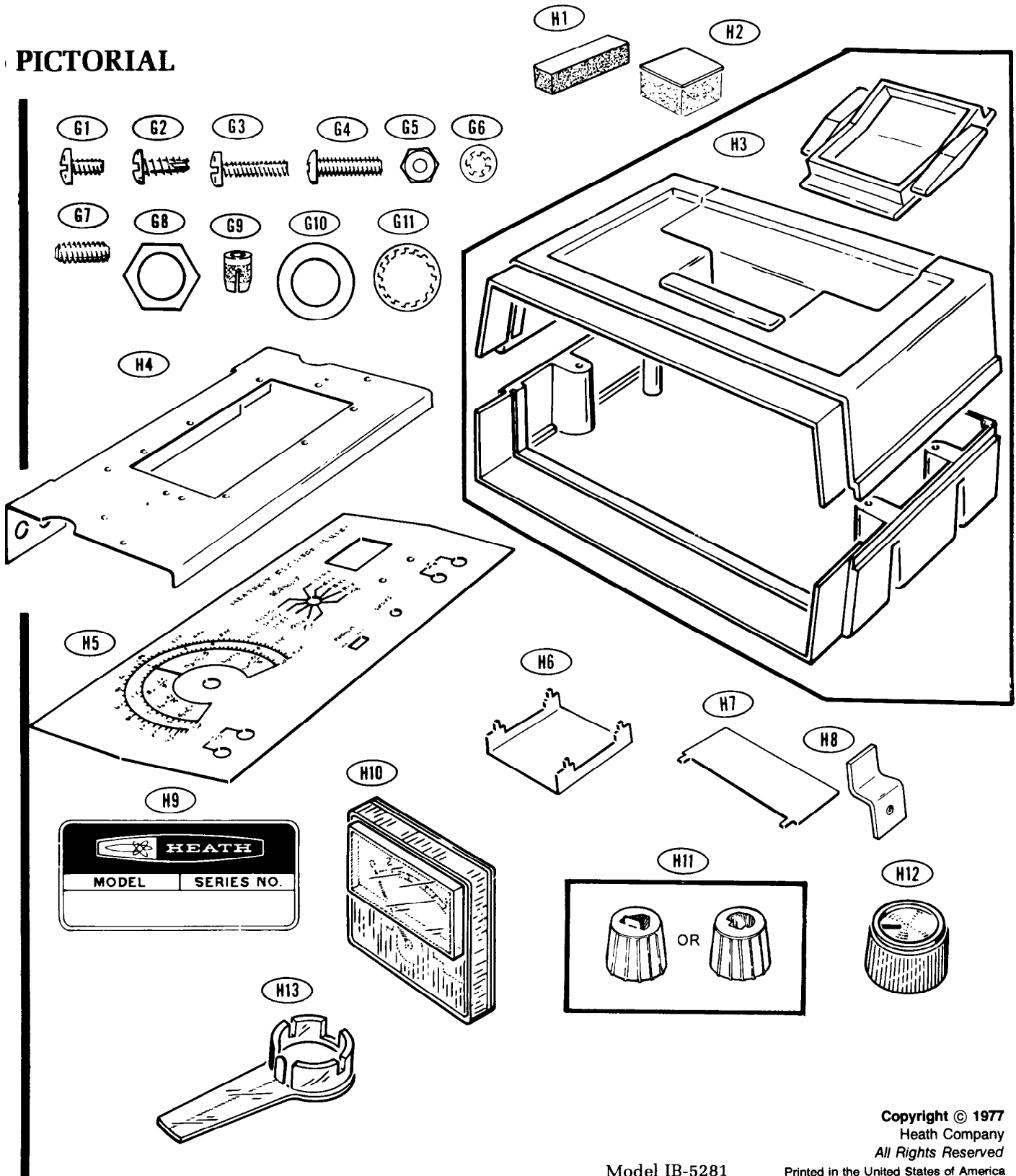

Copyright © 1977  
 Heath Company  
 All Rights Reserved

Model IB-5281

Printed in the United States of America

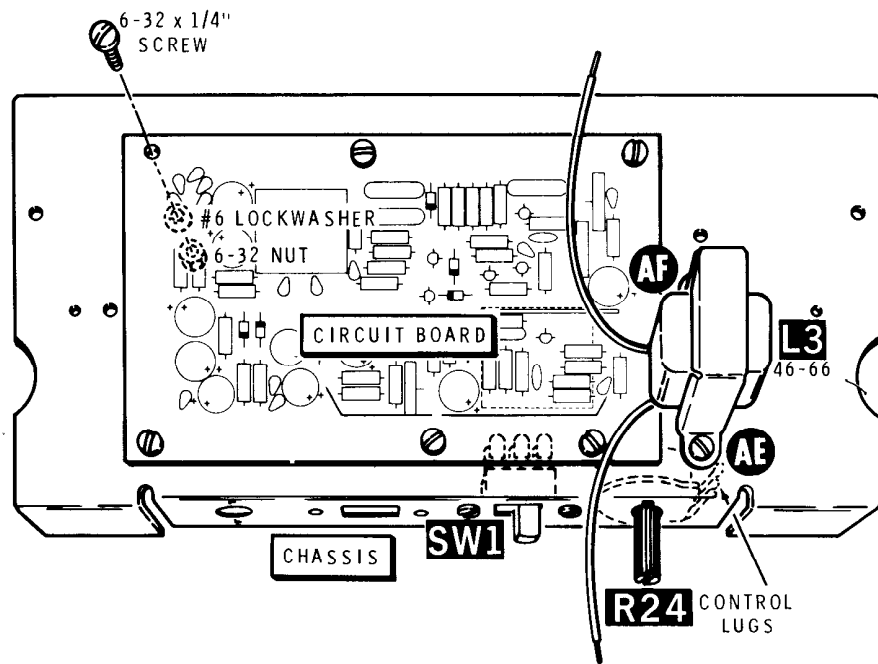

**PICTORIAL 3-1**

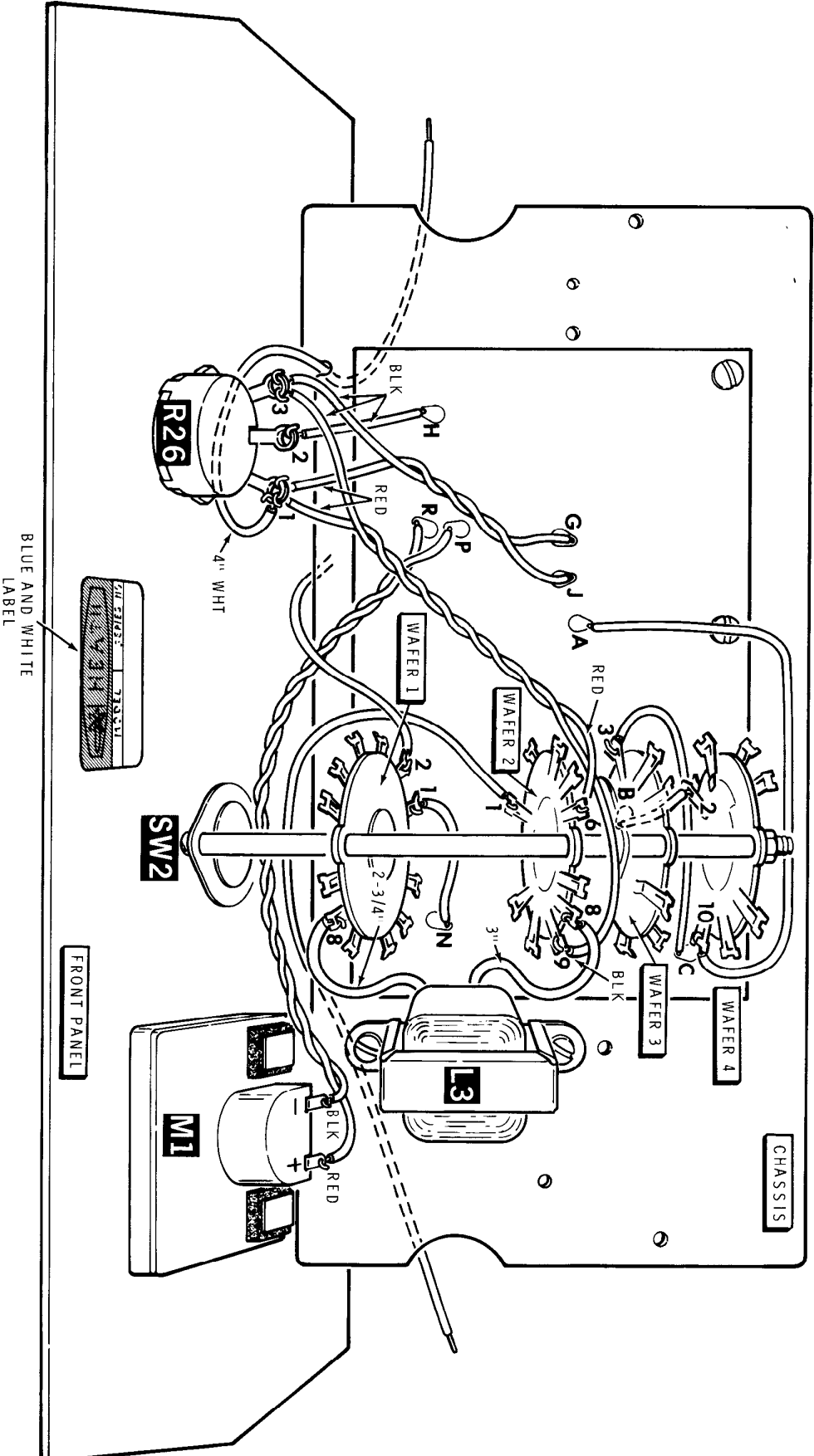

PICTORIAL 3-3

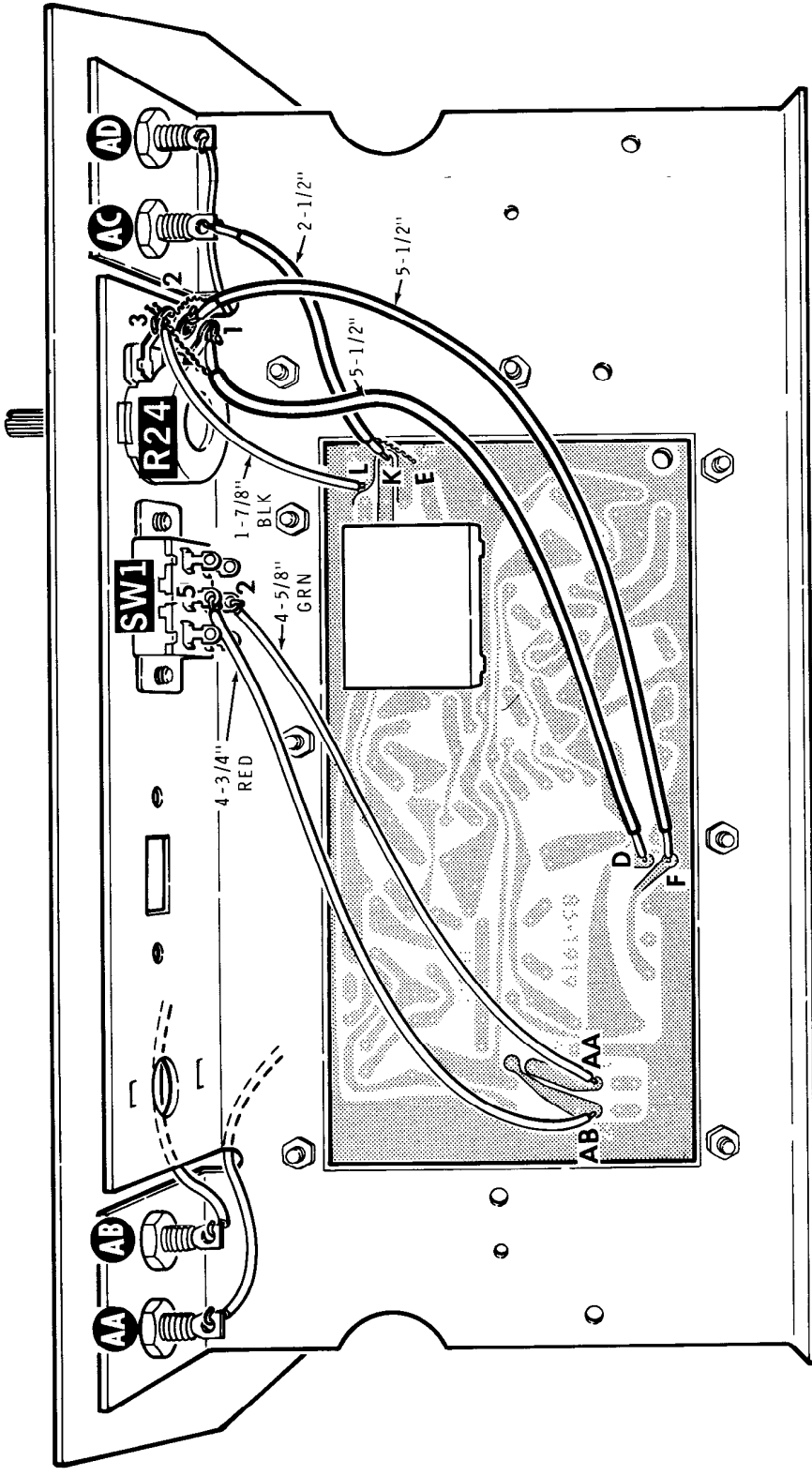

PICTORIAL 3-4

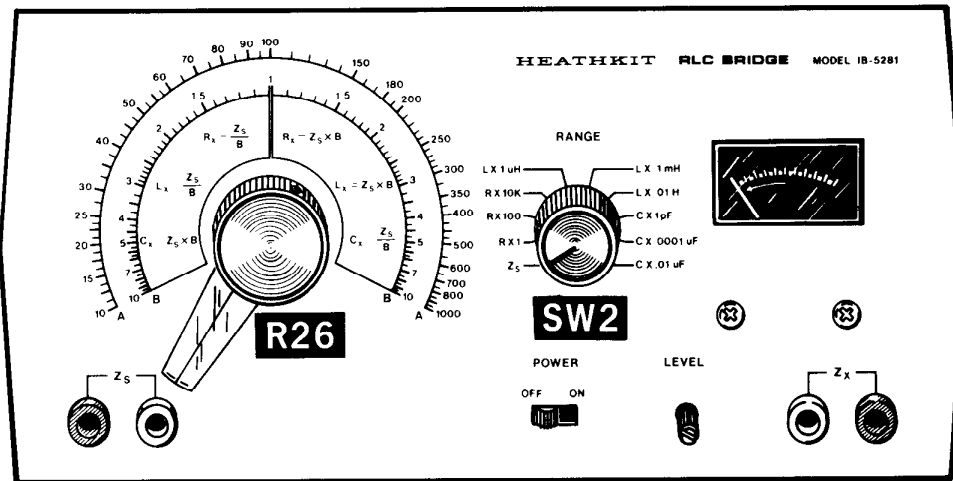
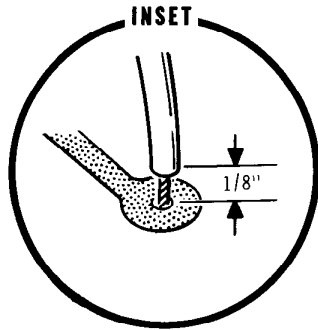

**FRONT PANEL**

**PICTORIAL 3-5**

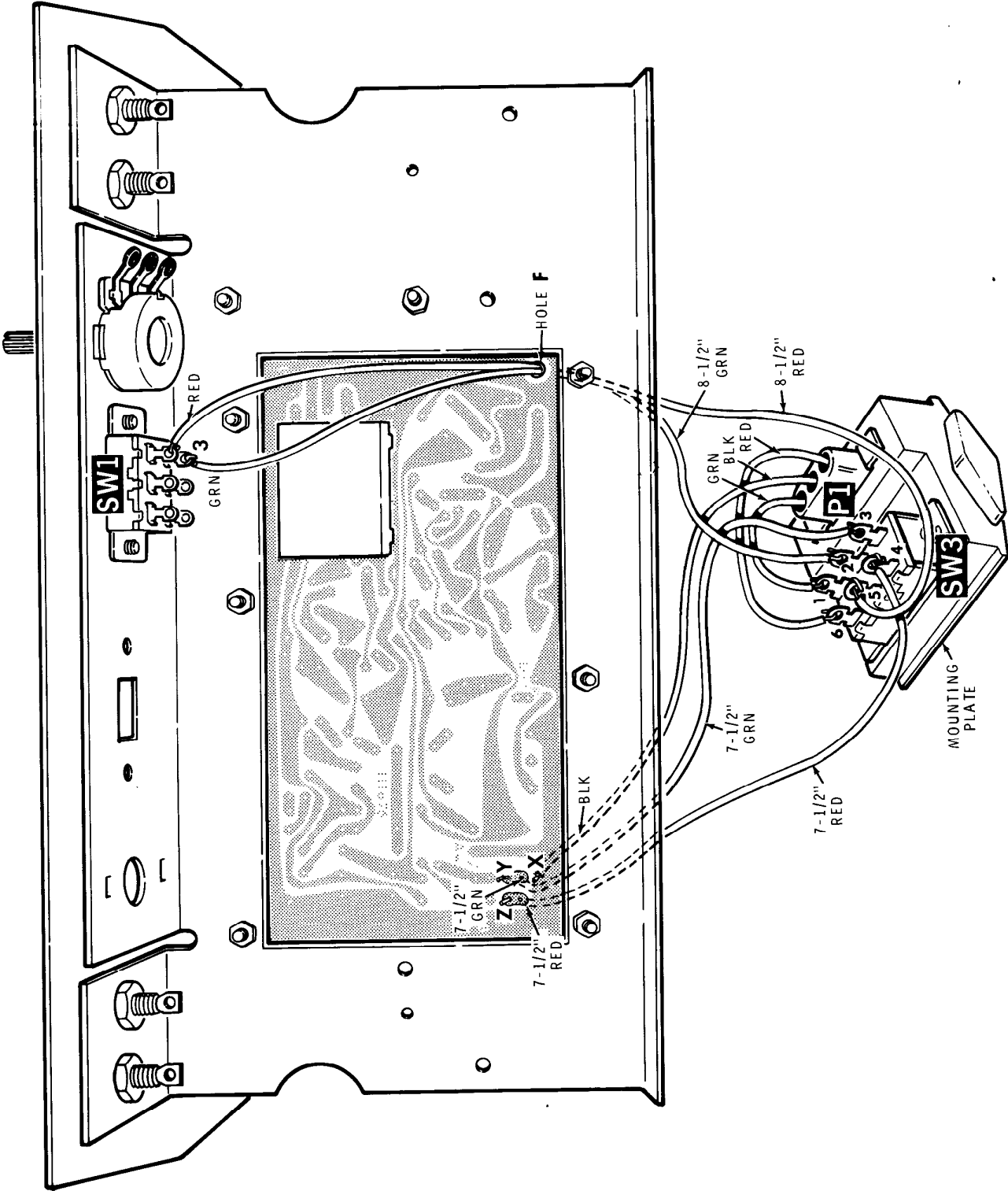

PICTORIAL 3-6

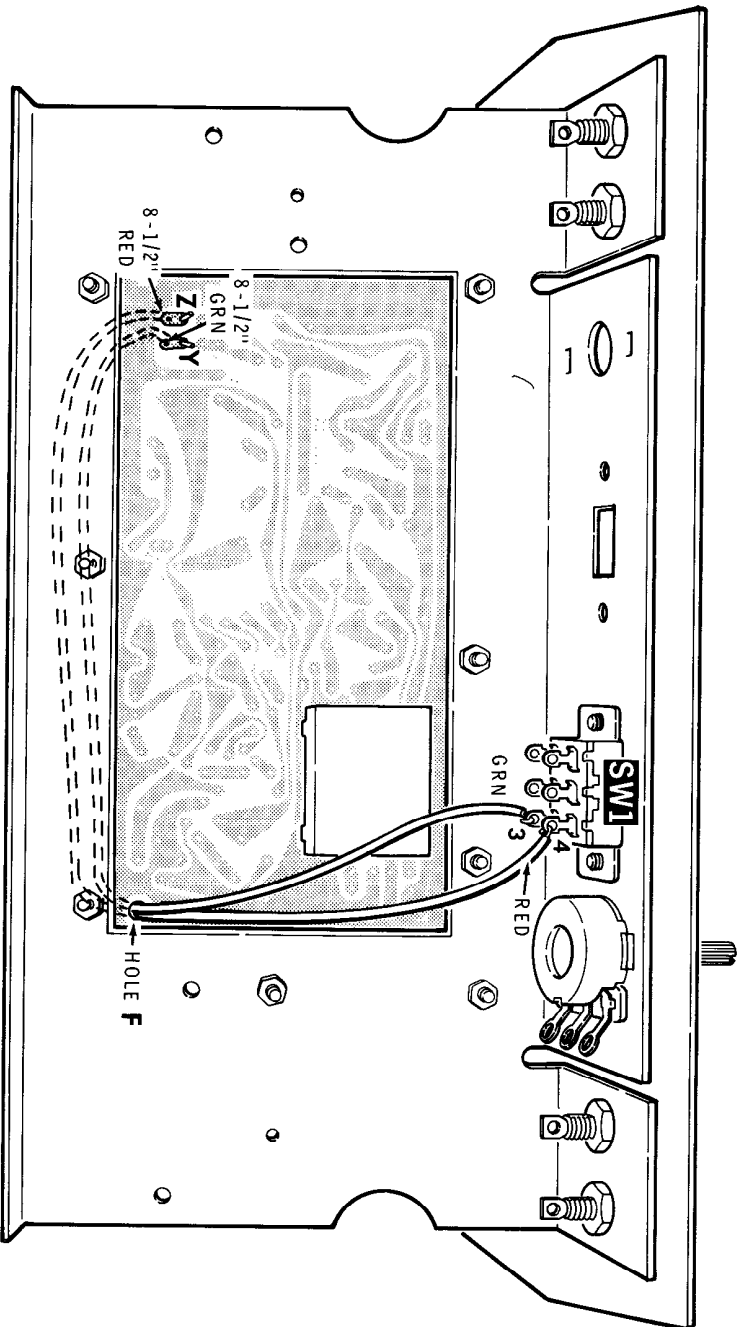

PICTORIAL 3-7



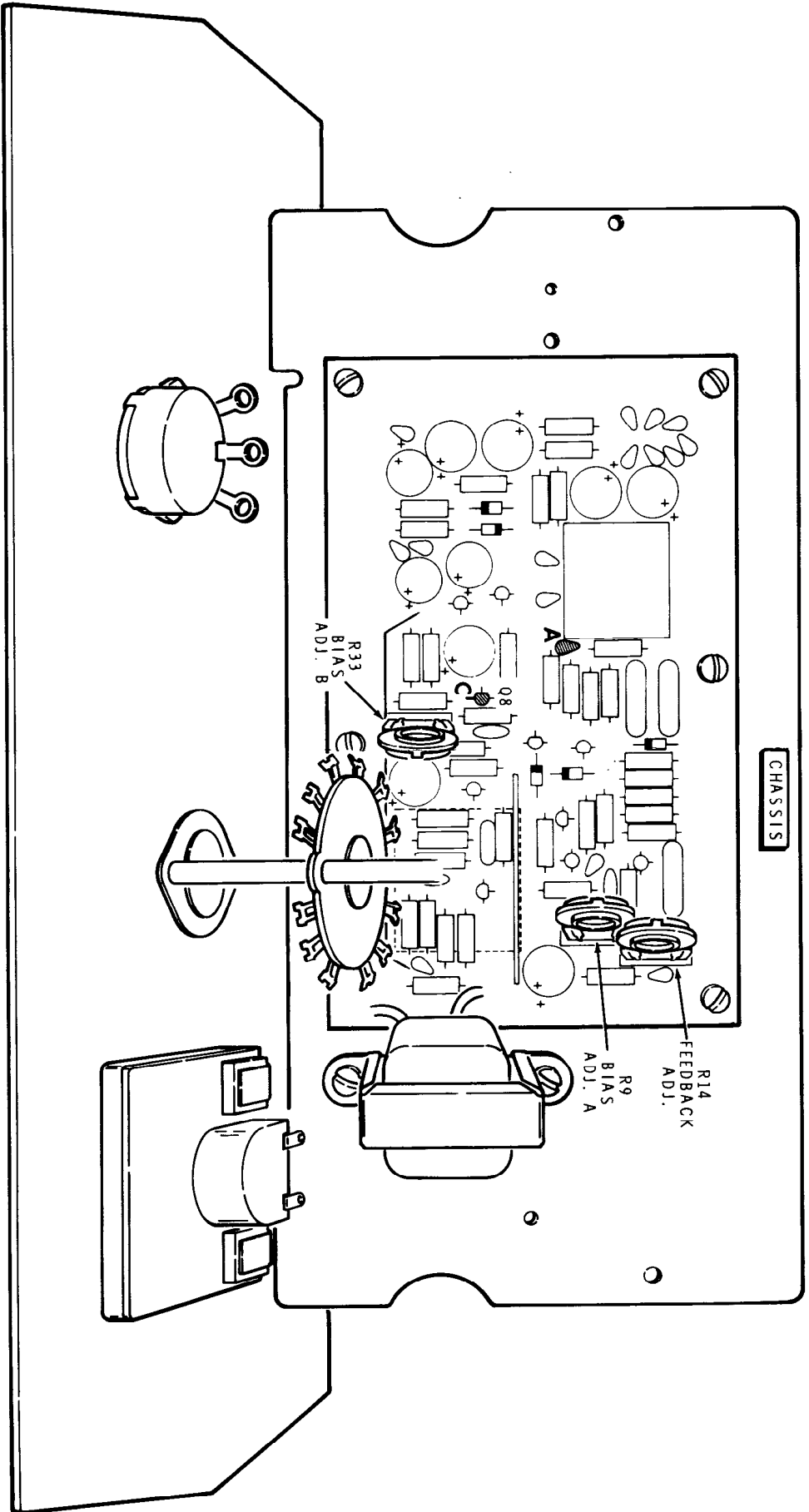

PICTORIAL 4-3

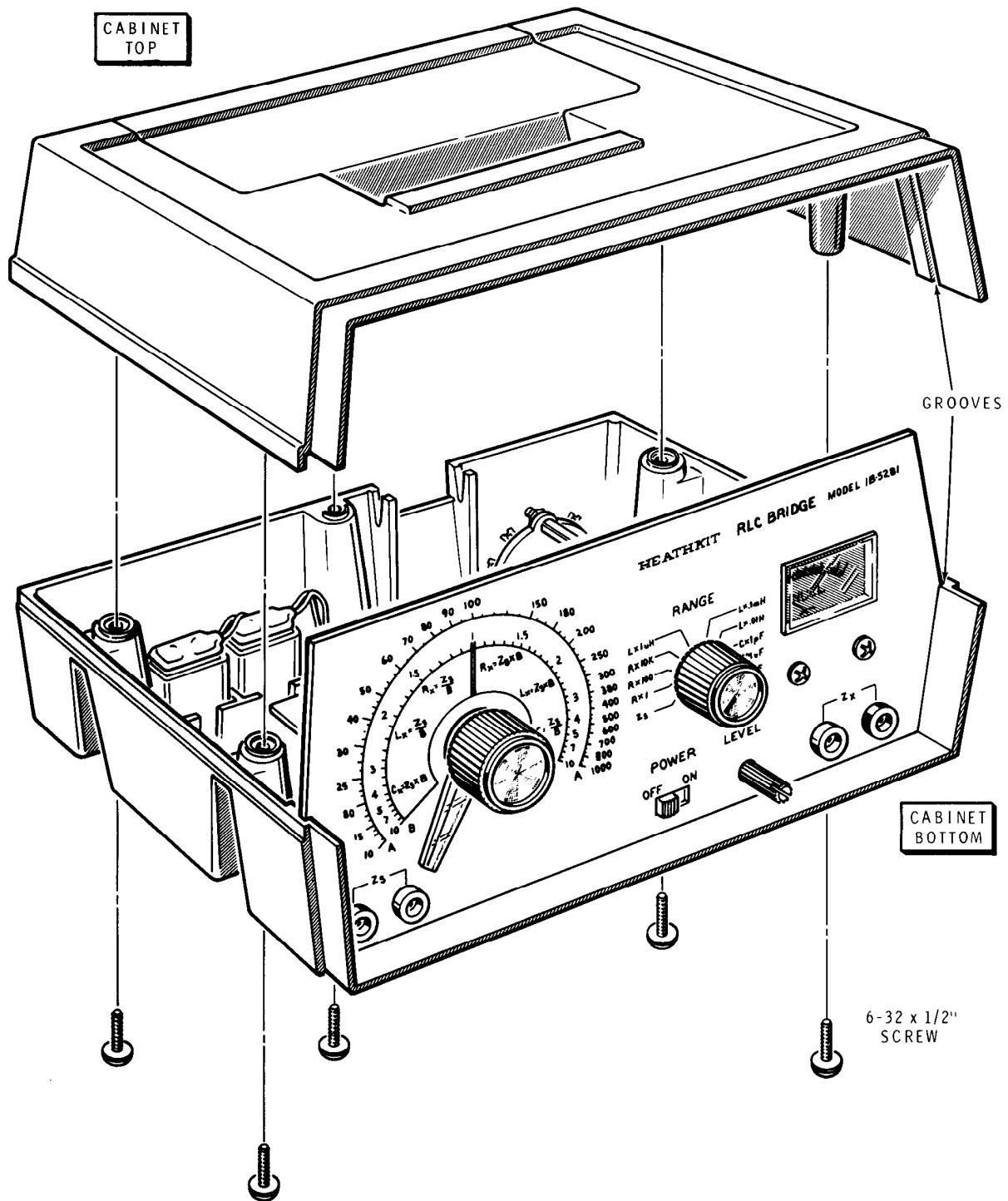

PICTORIAL 5-2

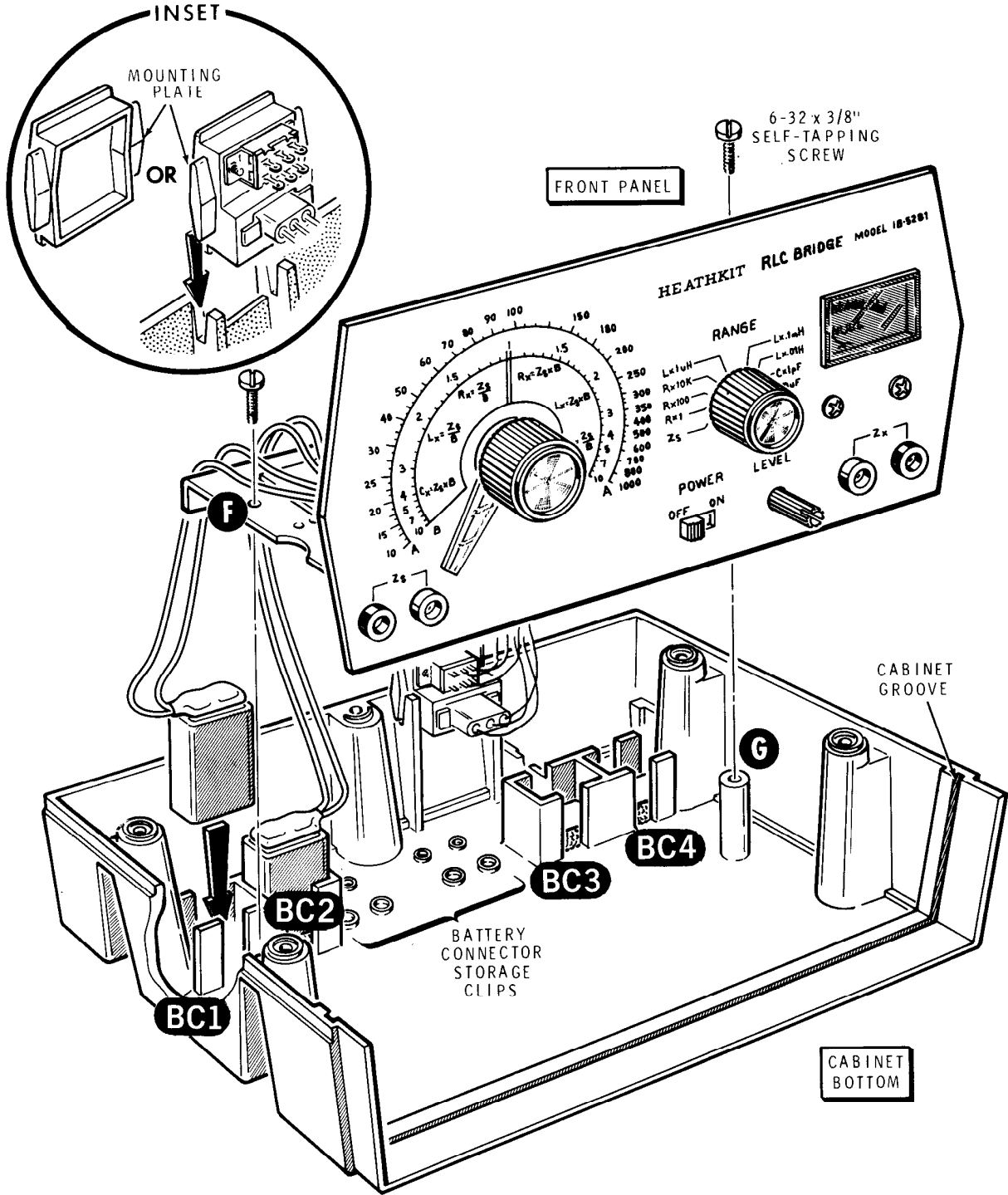

Detail 5-2B

**BALANCE CONTROL:** Varies the two arms of the bridge for balancing purposes.

**RANGE SWITCH:** Used to select the proper standard for the bridge circuit.

**METER:** Indicates when the bridge is balanced.

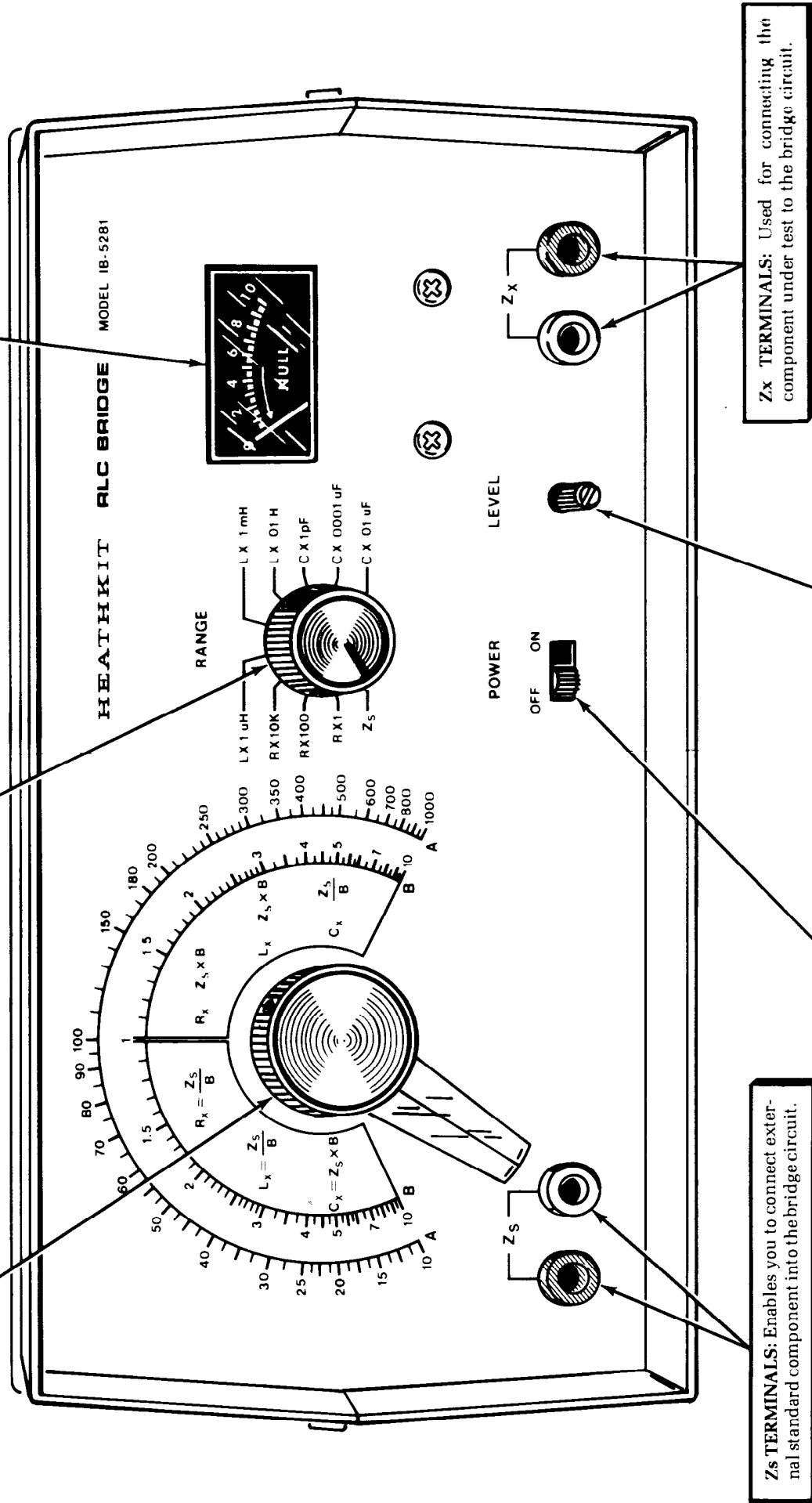

**Zs TERMINALS:** Enables you to connect external standard component into the bridge circuit.

**POWER ON-OFF SWITCH:** Used to turn the instrument on or off.

**LEVEL:** Used to select the proper working voltage when you check components.

**Zx TERMINALS:** Used for connecting the component under test to the bridge circuit.

**PICTORIAL 6-1**

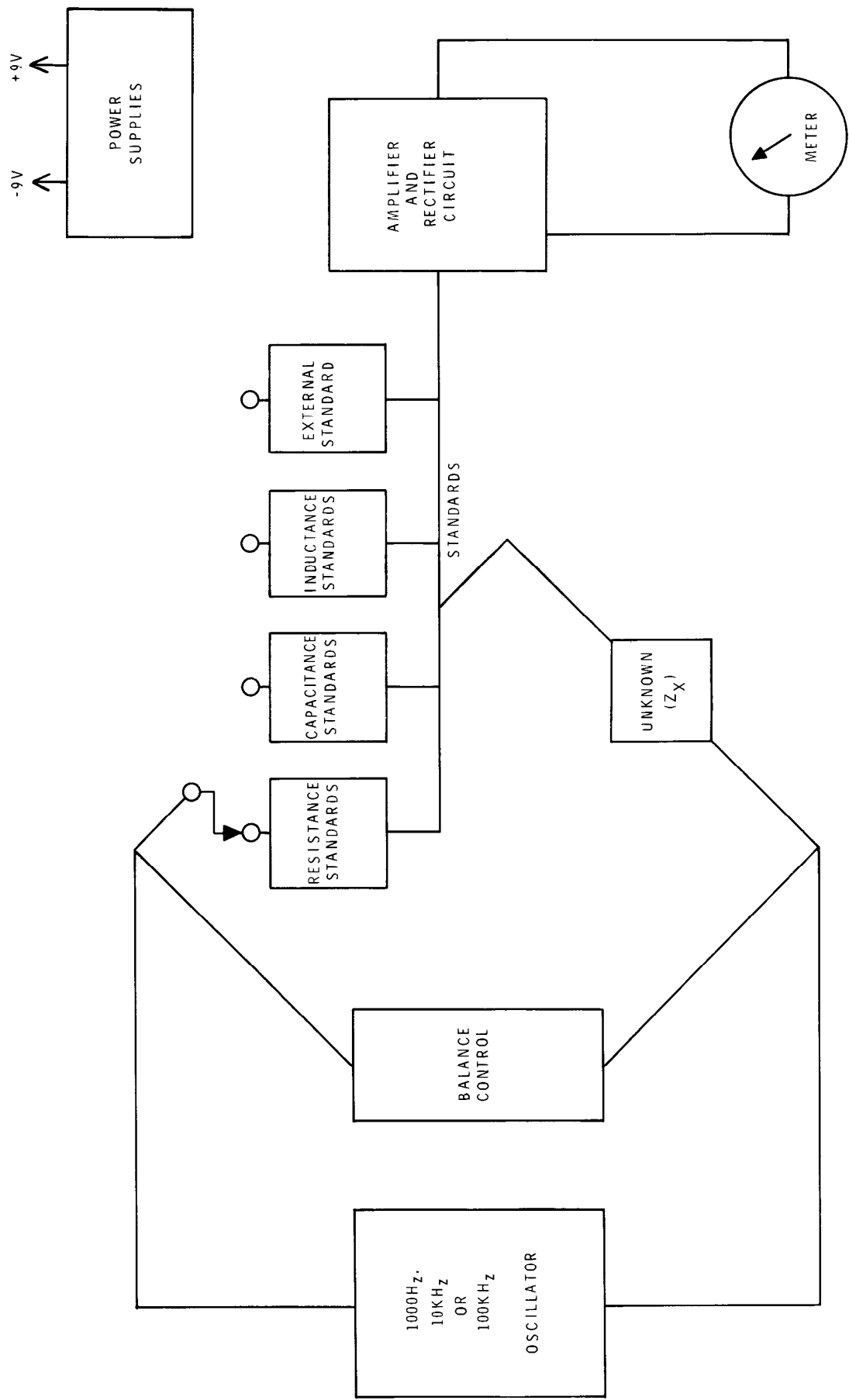

**BLOCK DIAGRAM**

**A**

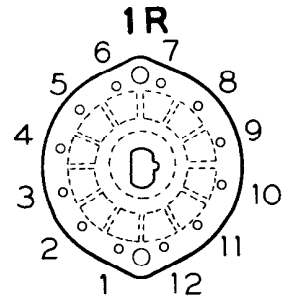
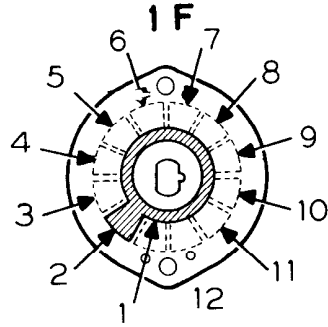
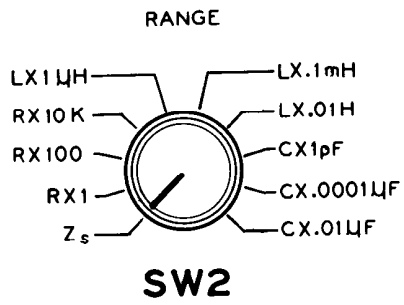
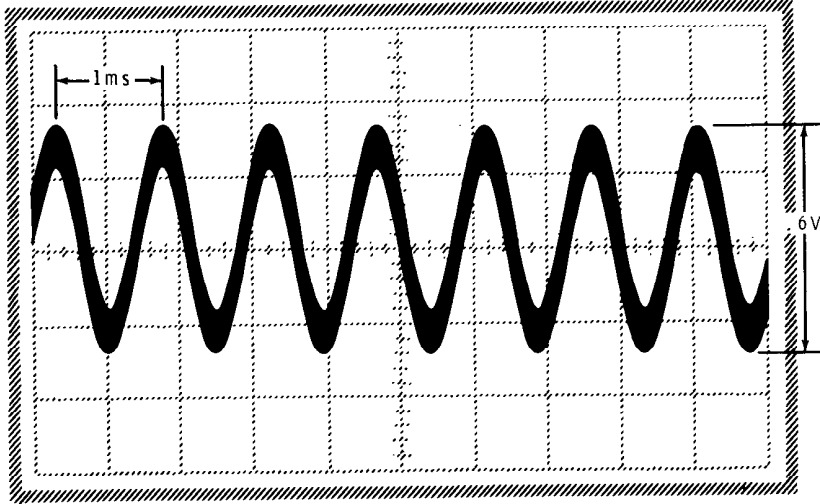

**B**

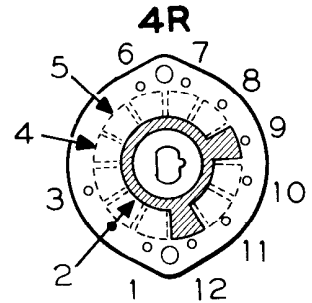
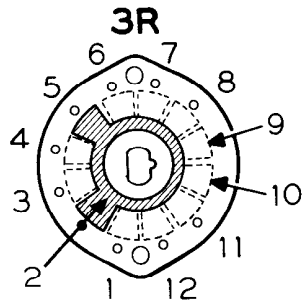
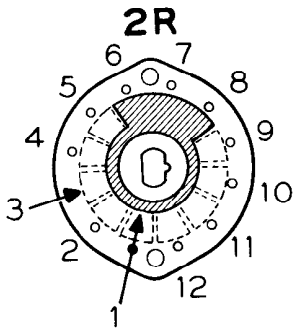
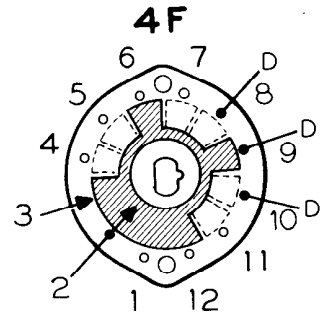
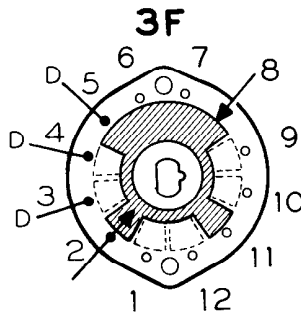
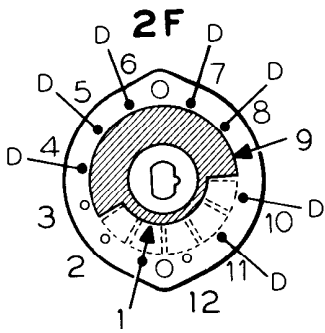
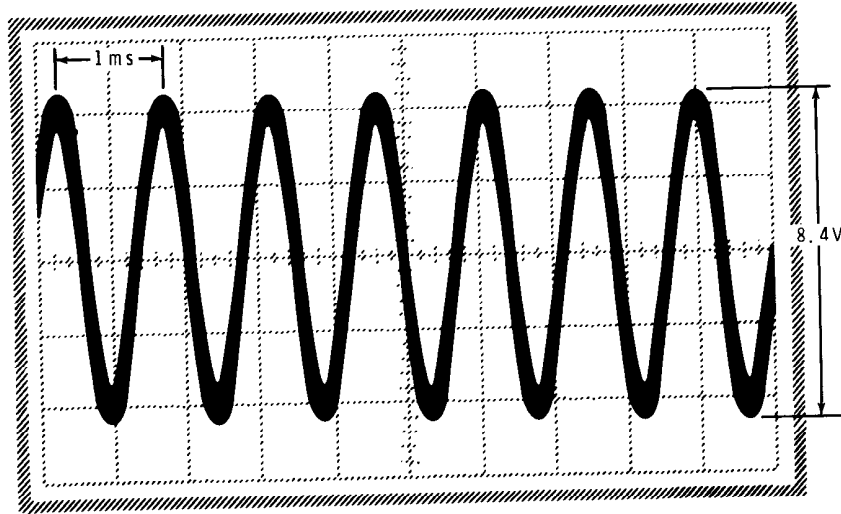

Ⓒ

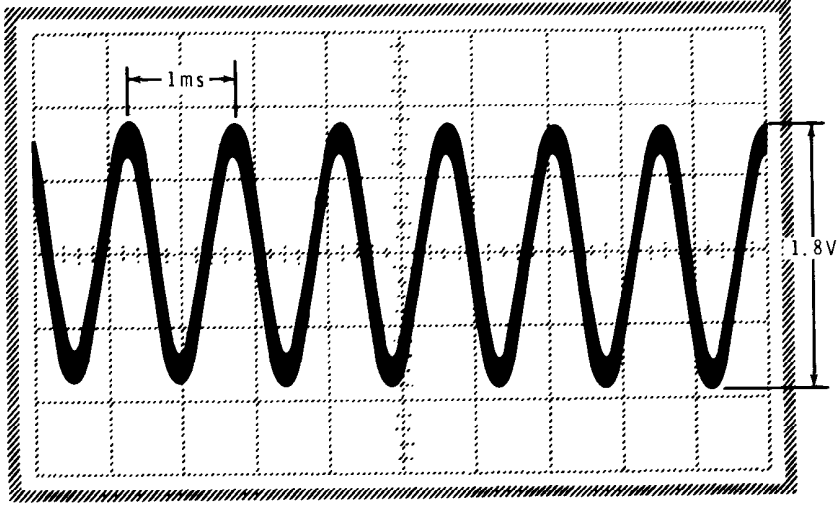

SCHEMATIC OF THE  
HEATHKIT®  
MODEL IB-5281  
RLC BRIDGE



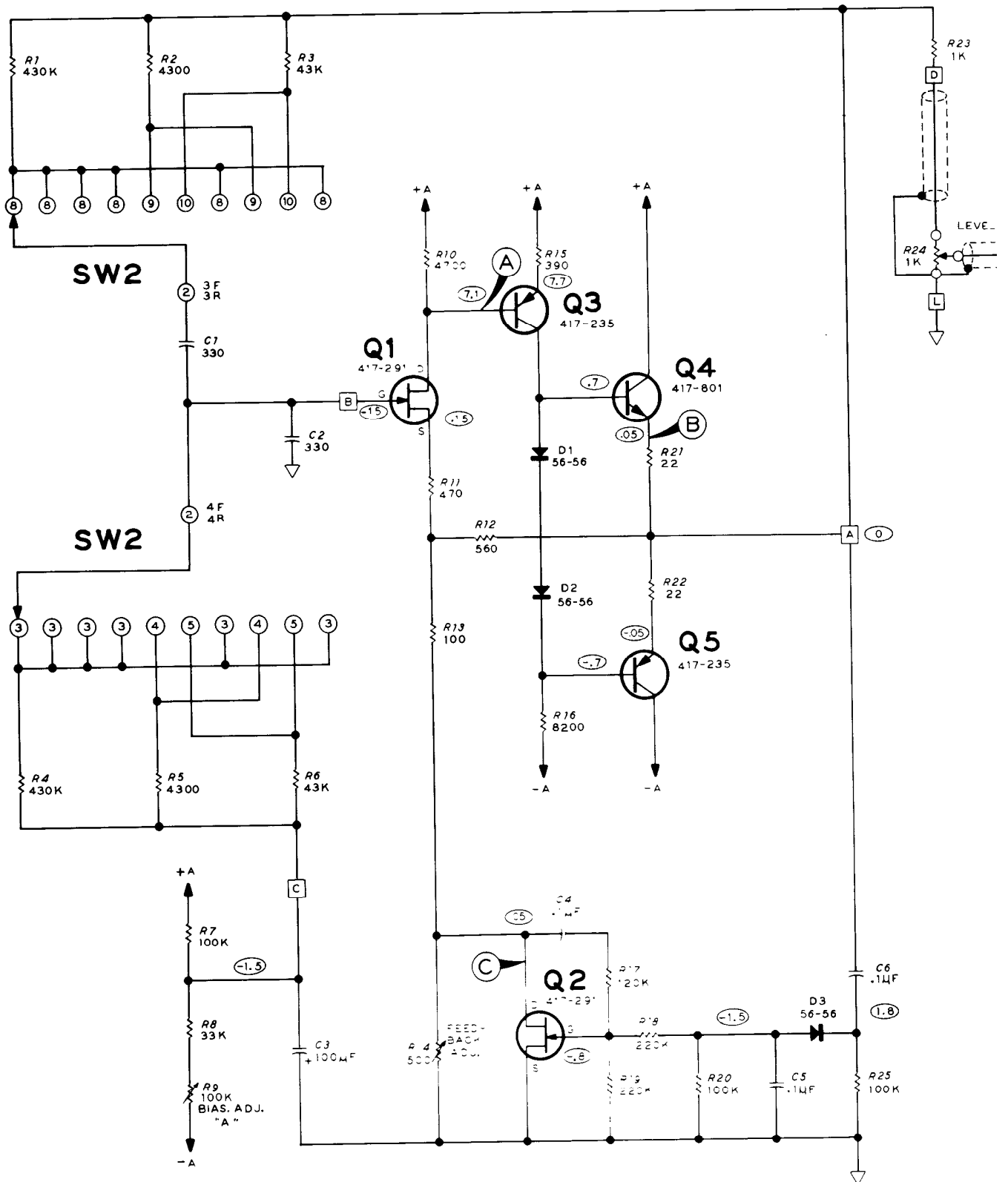

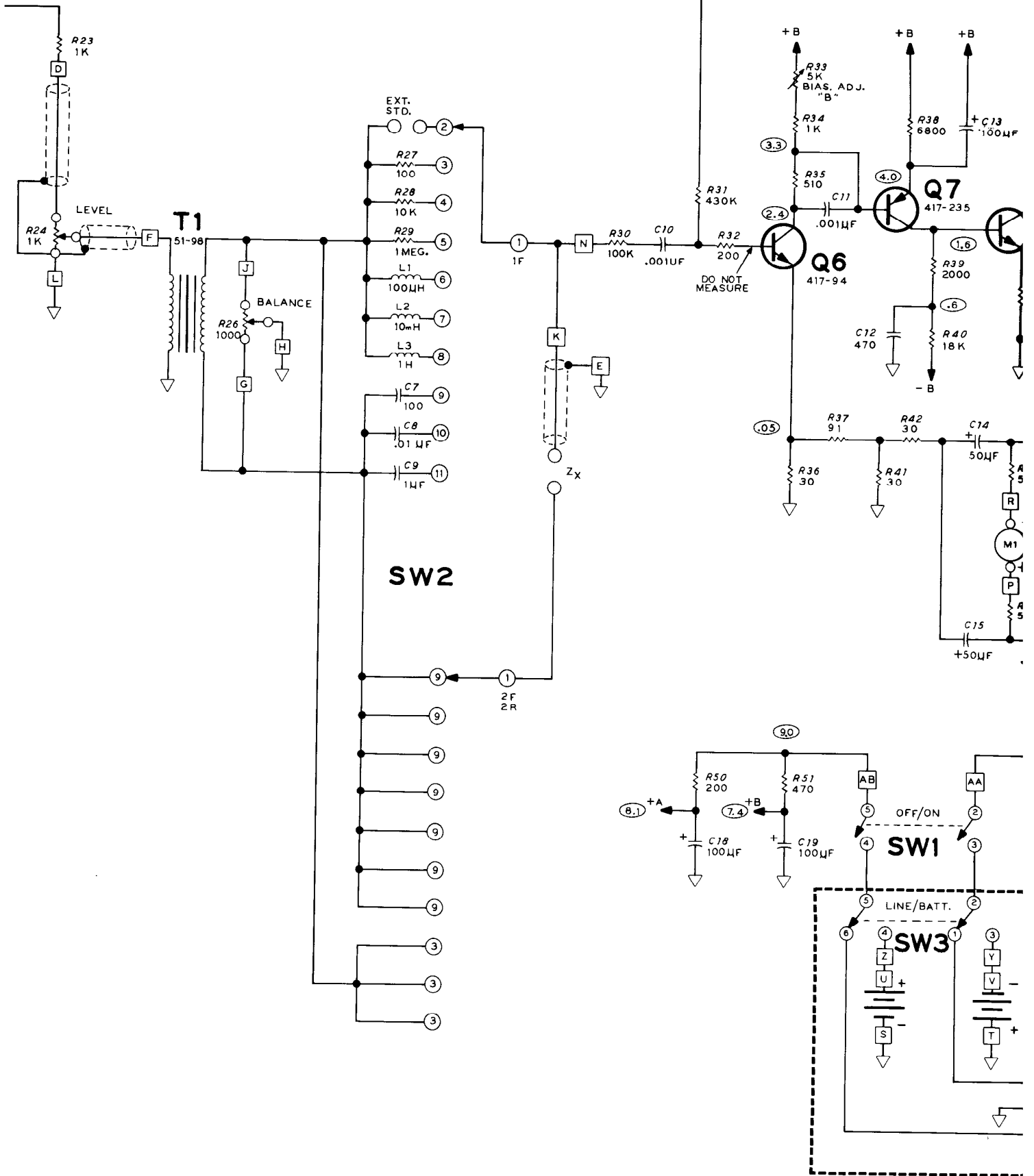

# SCHEMATIC OF THE HEATHKIT® MODEL IB-5281 RLC BRIDGE

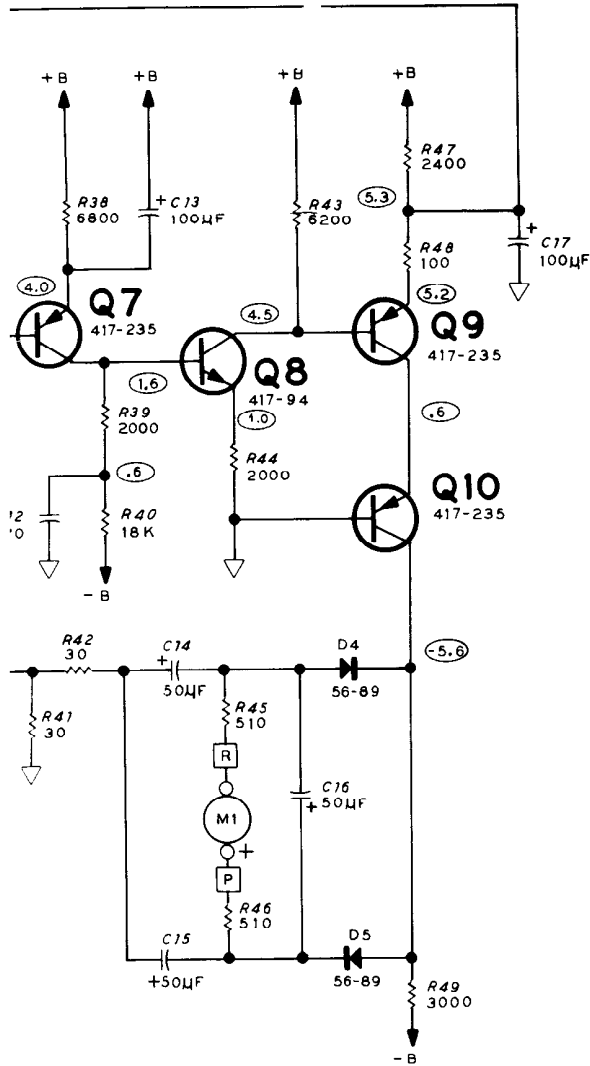

**NOTES:**

1. ALL RESISTORS ARE 1/2 WATT, 5% UNLESS OTHERWISE SPECIFIED. RESISTOR VALUES ARE IN OHMS (K=1,000, M=1,000,000).
2. CAPACITORS ARE IN PF UNLESS SPECIFIED OTHERWISE.
3. SW1 AND SW3 ARE SLIDE SWITCHES AND SW2 IS A ROTARY SWITCH.
4. ○ THIS SYMBOL INDICATES A DC VOLTAGE TAKEN UNDER THE FOLLOWING CONDITIONS FROM THE POINT INDICATED TO CHASSIS GROUND WITH A HIGH IMPEDANCE VOLTMETER:
  - A.  $Z_X=0$
  - B. LEVEL CONTROL-MAXIMUM CCW
  - C. BALANCE CONTROL-CENTERED
  - D. RANGE SWITCH-EXT. STD. ( $Z_S$ ).
5. ▽ THIS SYMBOL INDICATES CIRCUIT GROUND.
6. ○ THIS SYMBOL INDICATES A SWITCH LUG.
7. [A] THIS SYMBOL INDICATES A LETTERED CIRCUIT BOARD CONNECTION THAT IS SOLDERED.
8. VOLTAGES MAY VARY 10%.
9. +A AND -A INDICATE AC GENERATOR SUPPLY VOLTAGE.
10. +B AND -B INDICATE METER AMPLIFIER SUPPLY VOLTAGE.
11. WAVEFORMS ARE TAKEN WITH THE RANGE SWITCH AT THE  $Z_S$  POSITION.

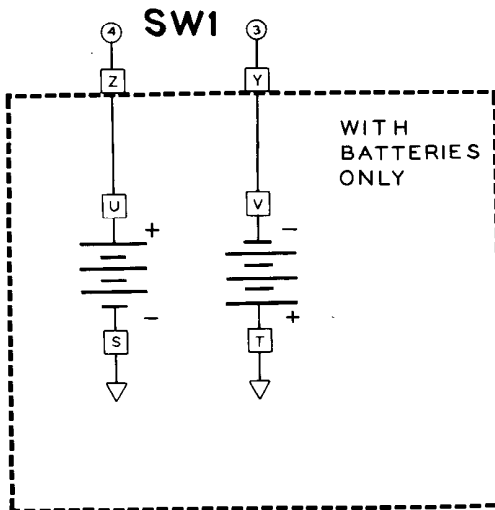
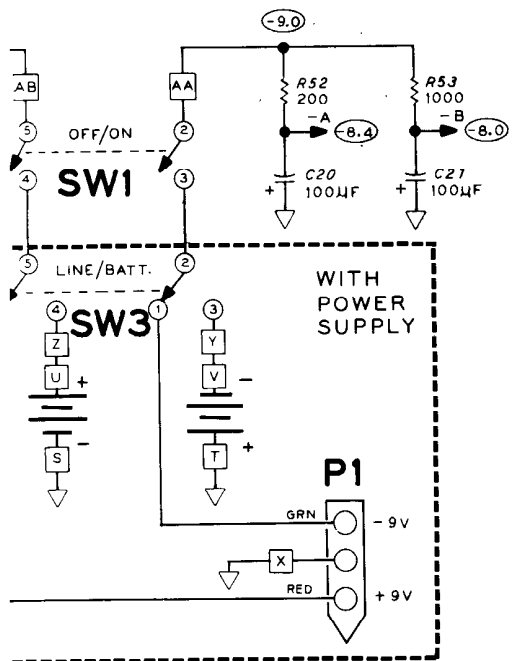

Part of 595-1958-03

# CUSTOMER SERVICE

## REPLACEMENT PARTS

Please provide complete information when you request replacements from either the factory or Heath Electronic Centers. Be certain to include the **HEATH** part number exactly as it appears in the parts list.

## ORDERING FROM THE FACTORY

Print all of the information requested on the parts order form furnished with this product and mail it to Heath. For telephone orders (parts only) dial 616 962-3571. If you are unable to locate an order form, write us a letter or card including:

- Heath part number.
- Model number.
- Date of purchase.
- Location purchased or invoice number.
- Nature of the defect.
- Your payment or authorization for COD shipment of parts not covered by warranty.

Mail letters to: Heath Company  
Benton Harbor  
MI 49022  
Attn: Parts Replacement

**Retain original parts until you receive replacements. Parts that should be returned to the factory will be listed on your packing slip.**

## OBTAINING REPLACEMENTS FROM HEATH ELECTRONIC CENTERS

For your convenience, "over the counter" replacement parts are available from the Heath Electronic Centers listed in your catalog. Be sure to bring in the original part and purchase invoice when you request a warranty replacement from a Heath Electronic Center.

## TECHNICAL CONSULTATION

Need help with your kit? — Self-Service? — Construction? — Operation? — Call or write for assistance. you'll find our Technical Consultants eager to help with just about any technical problem except "customizing" for unique applications.

The effectiveness of our consultation service depends on the information you furnish. Be sure to tell us:

- The Model number and Series number from the blue and white label.
- The date of purchase.
- An exact description of the difficulty.
- Everything you have done in attempting to correct the problem.

Also include switch positions, connections to other units, operating procedures, voltage readings, and any other information you think might be helpful.

**Please do not send parts for testing, unless this is specifically requested by our Consultants.**

Hints: Telephone traffic is lightest at midweek — please be sure your Manual and notes are on hand when you call.

Heathkit Electronic Center facilities are also available for telephone or "walk-in" personal assistance.

## REPAIR SERVICE

Service facilities are available, if they are needed, to repair your completed kit. (Kits that have been modified, soldered with paste flux or acid core solder, cannot be accepted for repair.)

**If it is convenient, personally deliver your kit to a Heathkit Electronic Center. For warranty parts replacement, supply a copy of the invoice or sales slip.**

If you prefer to ship your kit to the factory, attach a letter containing the following information directly to the unit:

- Your name and address.
- Date of purchase and invoice number.
- Copies of all correspondence relevant to the service of the kit.
- A brief description of the difficulty.
- Authorization to return your kit COD for the service and shipping charges. (This will reduce the possibility of delay.)

Check the equipment to see that all screws and parts are secured. (Do not include any wooden cabinets or color television picture tubes, as these are easily damaged in shipment. Do not include the kit Manual.) Place the equipment in a strong carton with at least **THREE INCHES** of resilient packing material (shredded paper, excelsior, etc.) on all sides. Use additional packing material where there are protrusions (control sticks, large knobs, etc.). If the unit weighs over 15 lbs., place this carton in another one with 3/4" of packing material between the two.

Seal the carton with reinforced gummed tape, tie it with a strong cord, and mark it "Fragile" on at least two sides. Remember, the carrier will not accept liability for shipping damage if the unit is insufficiently packed. Ship by prepaid express, United Parcel Service, or insured Parcel Post to:

Heath Company  
Service Department  
Benton Harbor, Michigan 49022





HEATH COMPANY • BENTON HARBOR, MICHIGAN  
**THE WORLD'S FINEST ELECTRONIC EQUIPMENT IN KIT FORM**

LITHO IN U.S.A.