



Service- Manual Dual 1215



Edition April 1970

Technical data

Current:	alternating, 50 or 60 cycle, with appropriate motor pulleys
Line voltage:	selector for 110 or 220 volts
Drive:	four-pole, single-phase, induction motor
Power consumption:	10 watts approximately at 220 V, 50 cycle
Current requirements:	64 ma. maximum at 220 V, 50 cycle; 115 ma. maximum at 117 V, 60 cycle
Turntable speeds:	33 1/3, 45 and 78 r.p.m.
Speed adjustment:	adjustment range of 1 semitone (6 %) at all three turntable speeds
Turntable:	non-magnetic, 4.4 lbs., Hi-Fi- turntable
Wow and flutter:	less than $\pm 0.12\%$
Rumble:	less than 42 dB below signal level) in accordance with
Signal-to-noise ratio:	less than 57 dB below signal level) DIN 45 500
Tonearm:	balanced on all three axes, extremely low mass, and precision, friction-free suspension (vertical 0.01 g and horizontal friction bearing, friction less than 0.04 g)
Cartridge holder:	removeable, suitable for acceptance of cartridges having 1/2" mounting and possessing a weight of 1-8 grams.
Weight:	11 lbs. without packing
Dimensions and mounting cutouts:	see installation instructions

Dual Gebrüder Steidinger · 7742 St. Georgen/Schwarzwald

Fig. 1 Tonearm hookup schematic

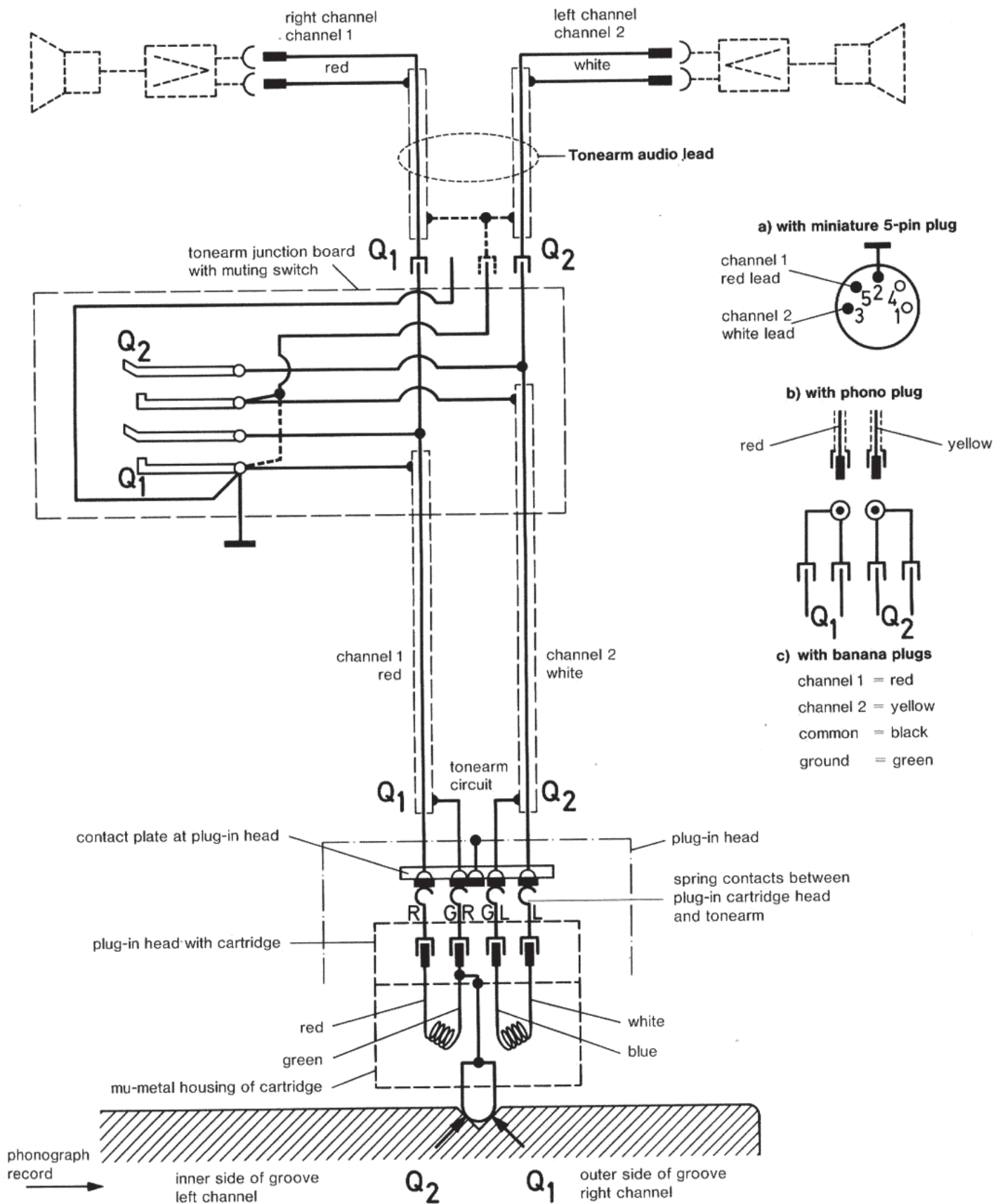

Contents

	Page
Technical data	1
Tonearm hook-up schematic	2
Motor and drive	4
Turntable does not turn when unit is plugged in and "start" switch operated	5
Turntable does not come up to speed	5
Assembly noise	5
Correct nominal speed obtained only at extreme settings of pitch control	5
Tonearm and suspension	6
Tonearm anti-skating mechanism	7
Stylus skips	7
Tonearm sets down beside tonearm rest	7
Horizontal pivot friction too high	7
Vertical movement of tonearm is impeded during set-down cycle	7
Tonearm movements	8
Tonearm set-down and lift	8
Tonearm misses edge of record	9
Tonearm strikes record during change cycle	9
Tonearm does not move on to record when drop cycle is started	9
Tonearm lowers too quickly when drop cycle is started	9
Tonearm returns to rest immediately after being placed on record manually	9
Start cycle	9,10
Manual start	10
Stop switching	10
Muting switch	11
Record drop	11
Shut-off and change cycle	11
Shut-off mechanism	12
Turntable stops after automatic set-down of the tonearm	12
Last record keeps repeating	12
Record does not drop when unit is switched to "start"	13
Record drops when unit is switched to "stop"	13
Records do not drop	13
Switch latches into "stop" position when tonearm is at rest	14
Tonearm moves with stylus force and anti-skating force at zero	14
Noise during change, stop and start operations	14
No sound	14
Motor continues to run after tonearm returns to its rest	14
Acoustic feedback	14
Replacement parts and exploded view	15-20
Lubrication	21-22

Fig. 2 Motor suspension and turntable drive

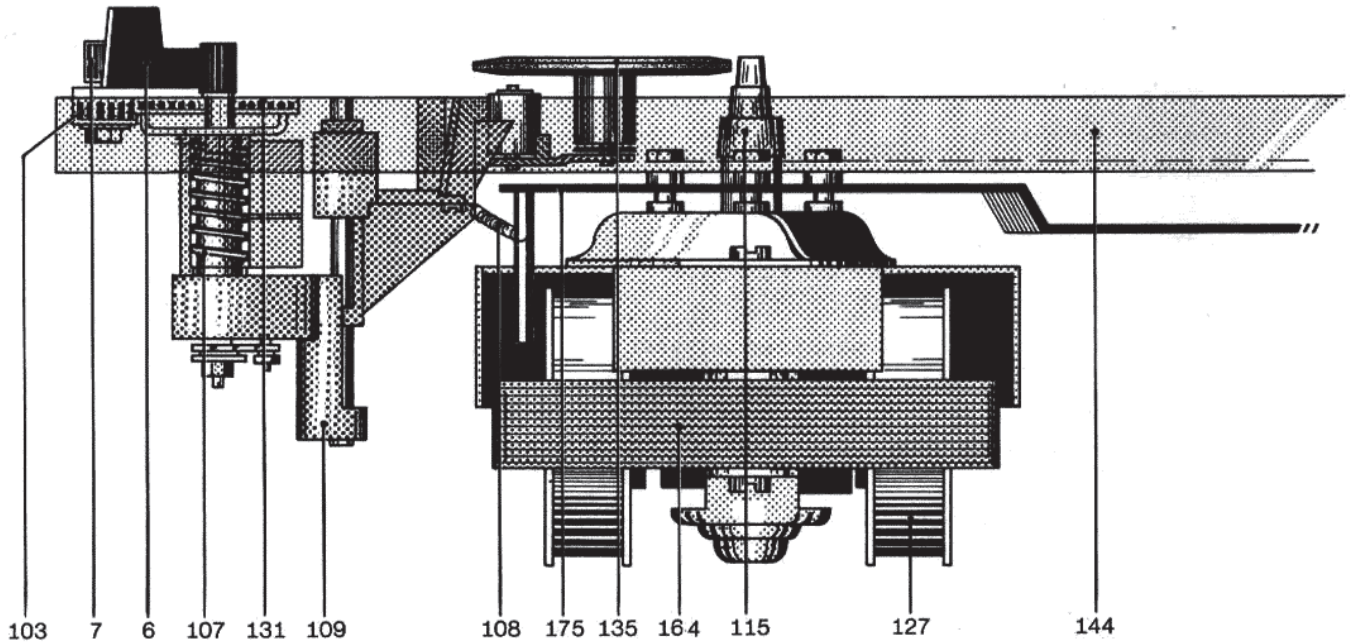

Motor and drive

The turntable platter and change mechanism are driven by a vibration-free four-pole motor (164) with an extremely low stray magnetic field.

Motor speed is constant for line-voltage variations of $\pm 10\%$. It is dependent on (and proportional to) line frequency. Two interchangeable motor pulleys (115) are available for adapting the changer to 50 or 60 Hz operation:

Motor pulley for 50 Hz operation: part no. 220 970
 Motor pulley for 60 Hz operation: part no. 220 971

The motor pulley is fastened to the motor shaft by a setscrew. When you change pulleys,

be sure that the new pulley is set at the correct height (see page 5). The turntable platter is driven by the idler wheel (135), which, to prevent damage to its friction surfaces, is automatically disengaged when the unit is shut off. Setting the turntable speed to 33 1/3, 45 or 78 rpm is done by raising or lowering the idler to bear against the proper step of the motor pulley.

When the operating switch (6) is actuated, the switch segment (106) rotates, whereupon the switch (108) that runs in the groove of the switch segment is brought to bear upon the drive wheel (135), lifted off the motor pulley (115) and moved vertically to the proper step on the motor pulley, corresponding to the selected speed.

Fig. 3 Motor field connections (less voltage selector)

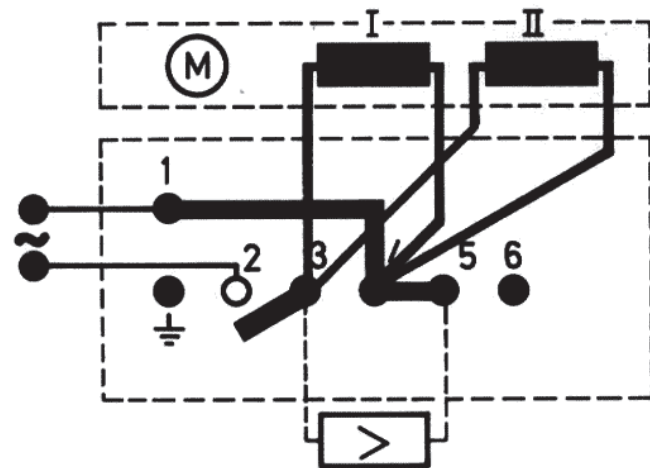

110/125 V

Fig. 4 Motor field connections (with voltage selector)

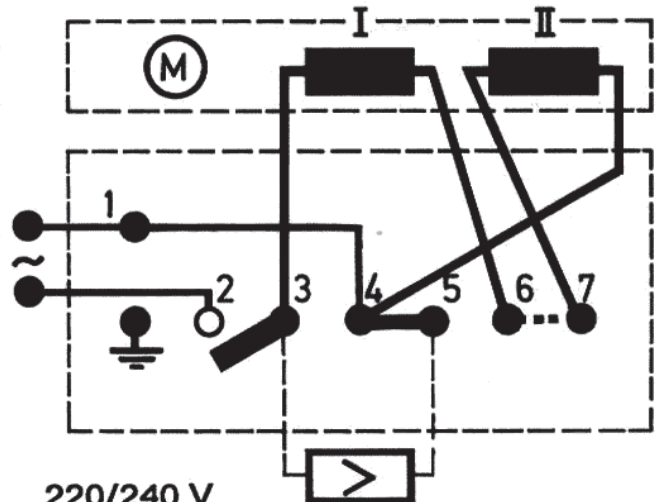

220/240 V

Fine-speed adjustment

A fine speed adjustment for all three speeds permits a platterspeed variation of 6% (about 1 semitone). Turning the pitch-control knob (7) causes the selector segment (106) to rotate. The switch lever assembly (108) moves up and down, changing the position of the idler wheel on whatever motor pulley step it has been placed on. The tapered shape of the motor pulley gives an adjustment range of $\pm 3\%$ from the nominal speed.

Symptom

Rumble in reproduction

Cause

Worn idler wheel

Remedy

Replace idler wheel (135) and clean platter drive surface and motor pulley with greaseless solvent. Once surfaces are cleaned, do not touch them with your fingers.

Fig. 5 Turntable speeds and drive wheel shift mechanism

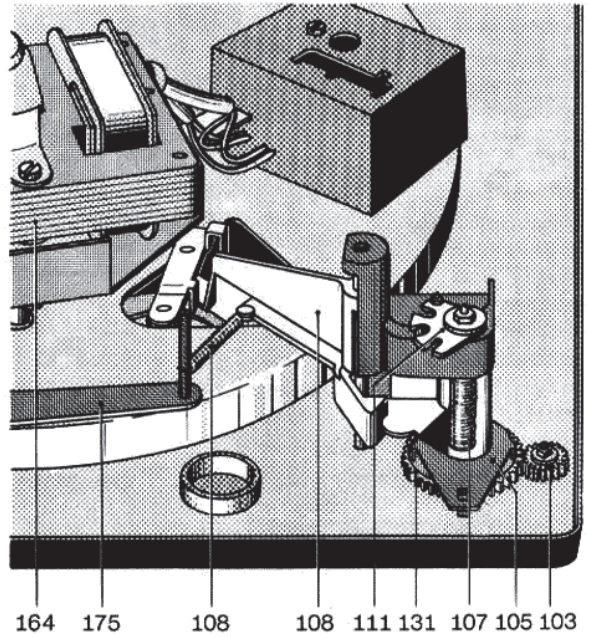

Symptom	Cause	Remedy
Turntable does not run when unit is plugged in and start switch operated	<ul style="list-style-type: none"> a) Current path to motor interrupted b) Idler wheel (135) not in contact with platter c) Motor pulley loose 	<ul style="list-style-type: none"> a) Check connection at switch plate and voltage selector b) Check switch lever assembly (108) c) Tighten motor pulley
Turntable does not come up to speed	<ul style="list-style-type: none"> a) Motor pulley is not correct for local line frequency b) Slippage between idler wheel (135) and motor pulley or platter c) Excessive friction in motor, drive wheel or platter bearings 	<ul style="list-style-type: none"> a) Change motor pulley b) Clean friction surfaces of idler wheel, motor pulley and turntable platter. If necessary, replace drive wheel. Once the drive surface of the platter has been cleaned, do not touch it with your fingers. c) Clean and oil bearings

Symptom

Correct nominal speed obtained only at extreme settings of pitch control

Cause

- a) Idler wheel does not contact motor pulley correctly
- b) The changer is resting with the bottom motor bearing on the base plate.

Remedy

- a) Adjust the motor pulley vertically after loosening its setscrew (114). Or adjust the idler wheel (135) by turning its shaft after loosening the locknut. The correct position for the idler is in the center of each motor pulley step, when the pitch control is centered in its range. Retighten locknut after adjustments.
- b) Eliminate the condition; changer must be suspended only by the three spring suspension points. Check idler wheel positioning.

Fig. 6 Motor pulley position

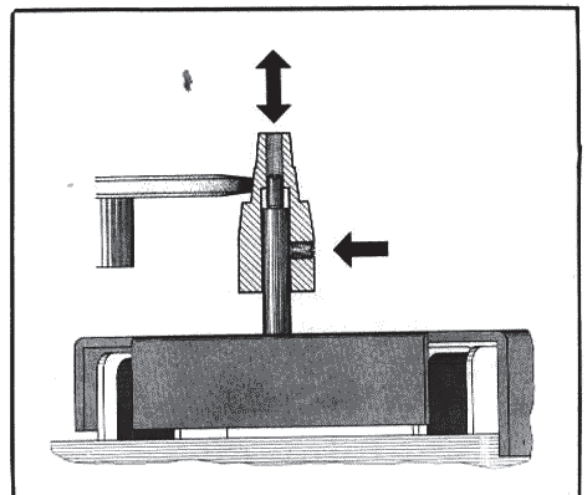

Fig. 7 Tonearm bearing assembly

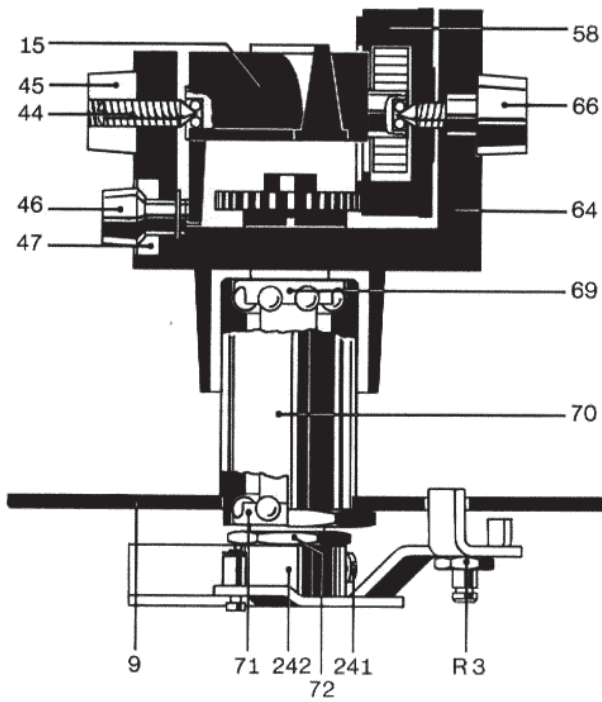
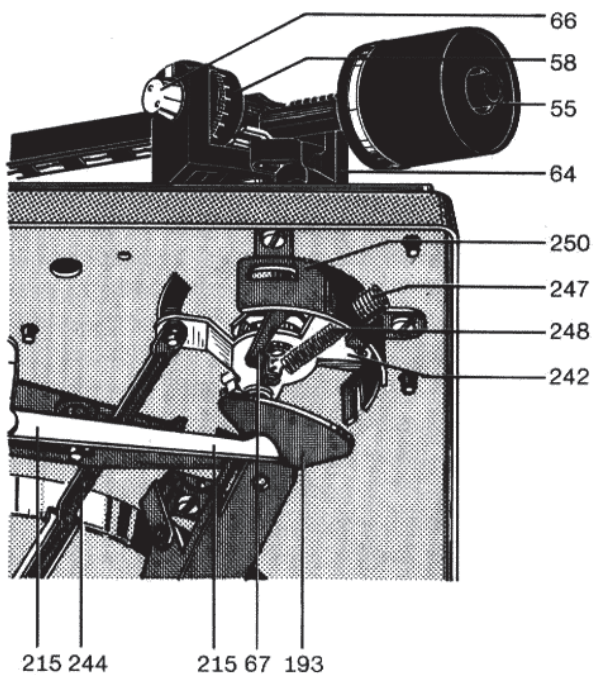

Fig. 8 Tonearm bearing assembly (under view)



The tonearm and its suspension

The all-metal tonearm of the Dual 1215 runs on vertical needle bearings and on horizontal precision ball bearings in hardened and polished races.

Vertical pivot friction = 0.01 gram
 Horizontal pivot friction = 0.04 gram
 referred to stylus tip

The arm is thus able to track extremely well. Before setting the tracking force for the cartridge being used, set the tracking-force scale to zero and balance the tonearm. This is done by rotating the counterweight clockwise or counter-clockwise.

To reduce the effects of small shock impulses to the arm, the counterbalance weight is elastically mounted on the tonearm, and friction-braked to prevent undesired rotation.

The cartridge holder will accept all cartridges with standard mounting centers of 1/2 inch. Stylus force is set by turning a calibrated dial, which stresses or releases a spiral spring contained inside. The dial covers a stylus-force range of zero to 5.5 grams and is marked over that range in 0.5 gram steps.

To replace the tonearm and tonearm suspension, unsolder the audio leads and remove main lever (193) and connecting lever (215). After removing the C-ring and washer from the shut-off slide, separate it from the adjusting screw (R 3) on the segment. Unhook tension spring (248) and loosen screws (239, 241) then remove the segment (242) and lift screw (230).

To loosen the nut (72), hold the bearing housing (70) between the base plate (9) and adjusting lever (67) with a suitable tool, such as flat (longnose) pliers. Carefully take out the tonearm, being especially careful not to bend the spring lever.

To re-install the tonearm and its assembly, reverse the above procedure. Before tightening screws (239/241), check the tonearm position over the tonearm rest, so that the tonearm can be lowered onto the rest without binding.

When the tonearm is installed, moving it in and out with the anti-skating lever in its zero position should not cause the tension spring (248) to move. If necessary, the adjustment can be corrected by means of the tab (LA) on the spring lever (67). Also, after re-installing the retaining spring for the tonearm leads, be sure that the arm segment (242) is not impeded by the tonearm leads.

To remove the tonearm from its mounting, unsolder the leads. Set the stylus-force adjustment to zero. Unscrew the locknut (45), setcrew (44) and mounting screw (66). Then carefully remove the tonearm from its mounting frame.

Anti-skating adjustment

The tendency of a tonearm with an off-set (angled) head to "skate" inward across the record is eliminated in the Dual 1215 by a precision anti-skating mechanism. The magnitude and direction of the compensating force are established automatically in proportion to the stylus force by a special cam. Skating force is a component of the frictional force between stylus and groove wall and depends on tonearm geometry and the properties of the record material. Particularly significant are the stylus force and the contour of the stylus tip; skating force increases with increased stylus force and decreased stylus-tip radius. It causes unequal pressure on the two facing groove walls, resulting in uneven wear, distortion and loss of stereo separation.

The optimum adjustment of the anti-skating mechanism is obtained with a needle curvature of 0.7 ± 0.1 mil. The adjusting screw is sealed; any re-adjustments should be done only with the aid of the Dual Skate-0-Meter and test record L 096, and preferably by an authorized service agency.

Fig. 9 Anti-skating

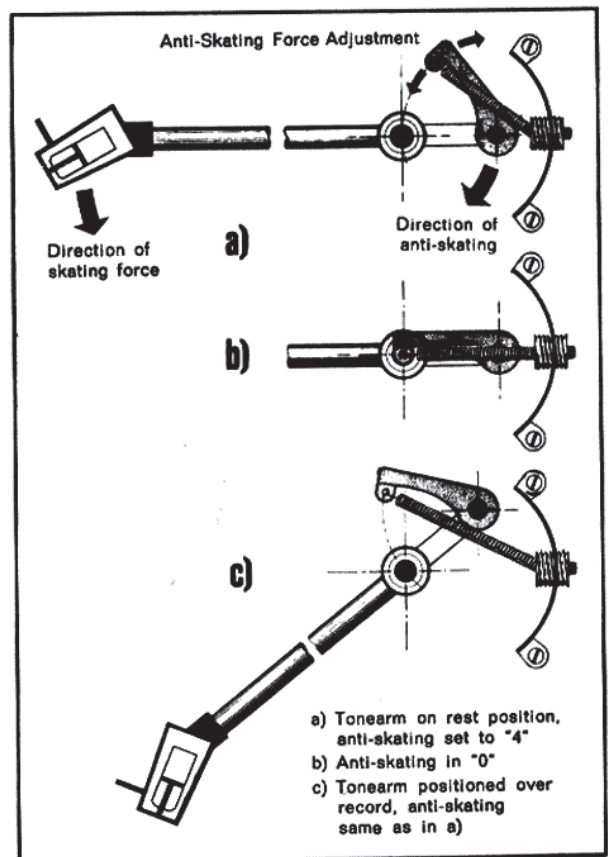

Troubleshooting chart

Symptom	Cause	Remedy
Stylus skips	a) Tonearm not balanced	a) Balance tonearm according to operating instructions
	b) Stylus force too low	b) Set stylus force to cartridge manufacturer's recommended value
	c) Stylus worn or chipped	c) Replace stylus
	d) Excessive friction in tonearm bearing	d) Check tonearm horizontal pivot. Should have barely noticeable play. Adjust vertical bearing only with the left bearing screw (44) and the horizontal bearing with nut (72). Horizontal bearing is correctly adjusted when the tonearm, with anti-skating 0.5 g, swings freely from center to rest.
	e) Ball (232) missing from shut-off rail	e) Replace ball (232)
Tonearm sets down beside tonearm rest	Arm segment (242) incorrectly adjusted	Correct adjustment: Loosen machine screws (239) and (241) and rotate segment (242) until adjustment is correct, namely when arm lowers on to rest without binding. Tighten screws.
Horizontal pivot friction too high	Tonearm is set too high on tonearm lift. Main lever jams against guide pin of lift screw assembly	Stylus should be no farther from record surface than 1/4". Adjust by turning screw 211.
Vertical movement of tonearm is impeded during set-down cycle	a) Bearing friction too high	a) Check bearing screw (44) and arm balance
	b) Lift screw (230) jams in guide sleeve of arm segment (242)	b) Remove and clean lift screw

Fig. 10 Tonearm guide mechanism

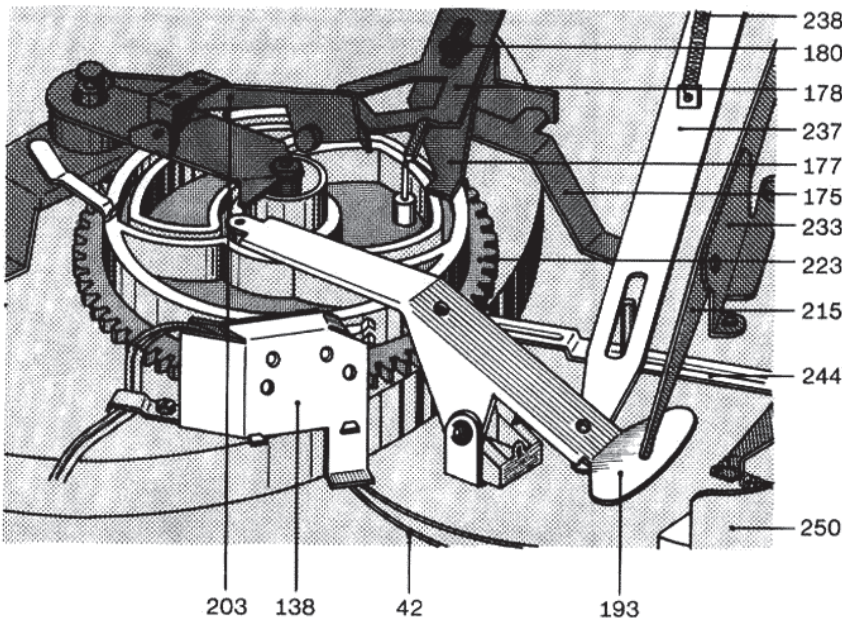

360°. Tonearm lift and lowering are controlled by the main lever (193) and the lift screw (230). Horizontal movements are controlled by the main lever (193) and the segment (242). Setting the changer for playback of 7", 10" or 12" discs is done with the indexing lever (23). Setdown points are determined by the eccentric portion of the arm positioning slide (237) and the indexing lever (236).

Horizontal movement of the tonearm is limited by the arm segment striking the arm positioning slide (237). During the change cycle, the main lever (193) raises the arm positioning slide, bringing it within reach of the spring stud. On completion of the change cycle (set-down of the tonearm on the record), the arm positioning slide (237) is again released and returns to its normal position. It thus moves out of reach of the spring stud, permitting the tonearm to move horizontally without hindrance, while playing the record.

Tonearm movements

A guide groove located on the underside of the main cam (223) controls the automatic lift and set-down of the tonearm as the cam rotates through

Tonearm lift (Cue control)

The tonearm lift permits the tonearm to be set down on the record safely at any desired point except the shut-off area (near the record label).

Pulling the tonearm lift towards the front turns the drive washer (208). This moves the connecting lever (215), main lever (193) and lift screw (230) to raise the tonearm.

After the tonearm is moved (by hand) to the desired spot on the record, the tonearm lift handle is lightly tapped towards the rear to

release the mechanism. The connecting lever (215) and the leaf spring (190) of the main lever (193) are freed, allowing the tonearm to fall. The rate of fall is controlled by silicone grease on the drive washer (208).

The height of the stylus above the record can be varied from zero to about 1/4" by adjusting setscrew (211). Turning it to the right increases the height, turning it to the left decreases the height.

Fig. 11 Tonearm lift (tonearm raised)

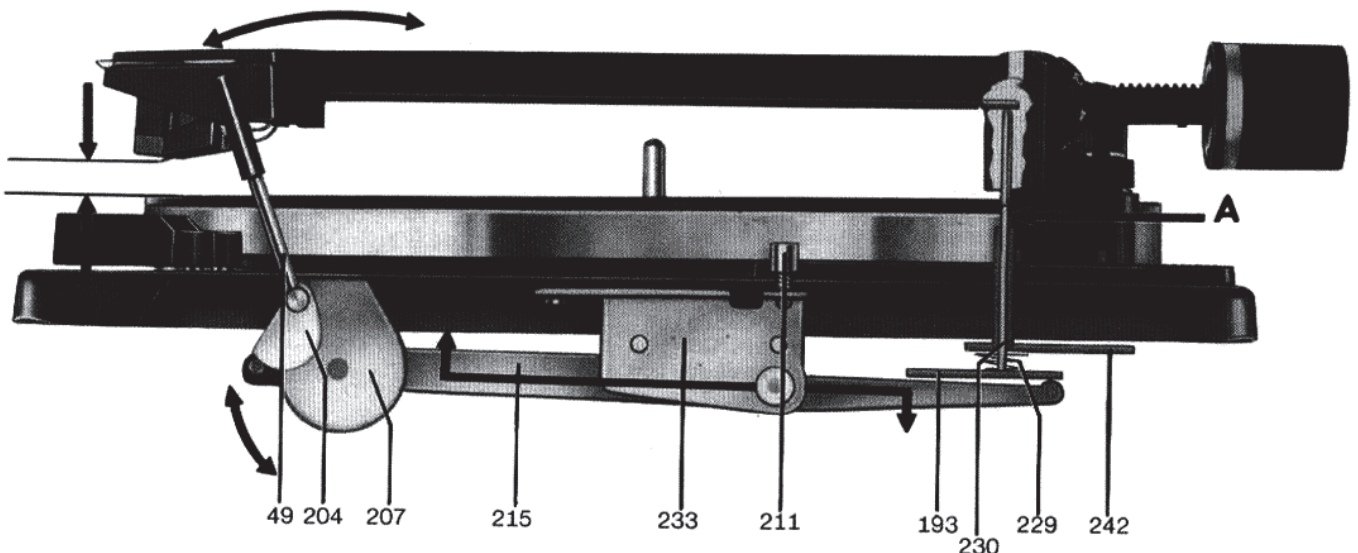

Troubleshooting chart

Symptom	Cause	Remedy
Stylus jumps out of record groove	Anti-skating adjustment incorrect	See operating instructions
Tonearm misses edge of record	a) Set-down incorrectly adjusted b) Record not standard size c) Friction surfaces of tonearm clutch dirty	a) Adjust set-down with a 12" record so that stylus touches record approximately 1/16" inside edge of record. Adjustment will be correct for other sizes. b) Use standard records c) Clean clutch surfaces
Tonearm strikes record during change cycle	Tonearm height incorrectly set	Adjust arm height with screw (46). Height is correct when stylus tip is 1/16" to 1/8" above start switch (24) when arm is removed from rest lowered.
Tonearm does not move on to record when drop cycle is started	Damping too great; drive washer dirty	Loosen nut (210) and washer (209) and coat both sides evenly with silicone grease. Reassemble and wipe off excess grease.
Tonearm lowers too quickly when drop cycle is started	Too little damping	Loosen nut (210) and washer (209) and drive washer (208). Clean thoroughly. Coat both sides evenly with silicone grease, re-assemble and wipe off excess.
Tonearm returns to rest immediately after being placed on record manually	Shut-off mechanism has shifted out of position during shipping	Before using changer after moving, run it through start cycle with tonearm locked on rest.

Start cycle

Moving the start switch (24) moves the switch lever (177) towards the main cam (223), initiating the following sequence.

- a) The set screw of the switch lever assembly (177) turns the switch arm (175) mounted on the grooved shaft (180). Via a tension spring, this actuates the rocker assembly (108) and engages the idler (135, Fig. 2) between the platter (5) and the motor pulley (115). At the same time, the power switch (148) is actuated by the switch slide (151) through the switch arm, and the turntable begins to rotate.
- b) The switch lever (177) is brought within reach of the cam follower lever (226), so that it is pushed into the change position after the rotation of the main cam.

Fig. 12 Start position

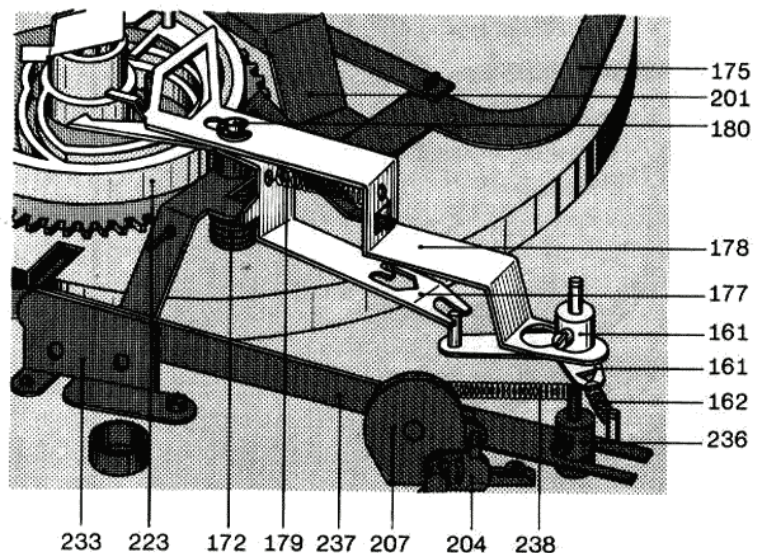
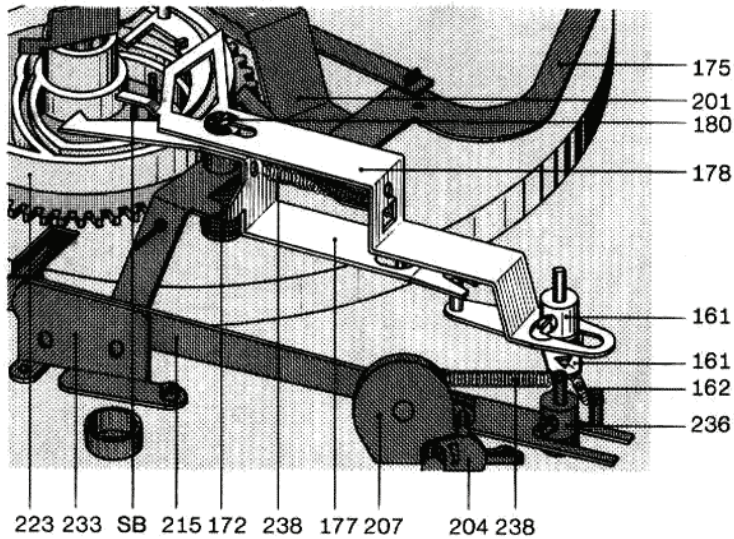

Fig. 13 Stop position



Moving the operating switch also releases the start lever (178), pulling it towards the main cam by means of the tension spring (179). This causes coil spring to bring the shut-off lever (217) within range of the main cam dog. Thus the shut-off lever drives the main cam.

To prevent malfunctioning, the operating switch is locked during the start cycle (that is, while the main cam is turning). Just before the main cam reaches its neutral position (at the end of the change cycle), the start lever is pushed clear of the main cam by the start pin (SB) of the main cam. This restores the switch lever and operating switch to their original positions.

After installation and also after moving the changer, the unit should be started with the tonearm locked on the rest. This will automatically re-adjust the shut-off lever, which may have shifted out of position.

Fig. 14 Muting switch

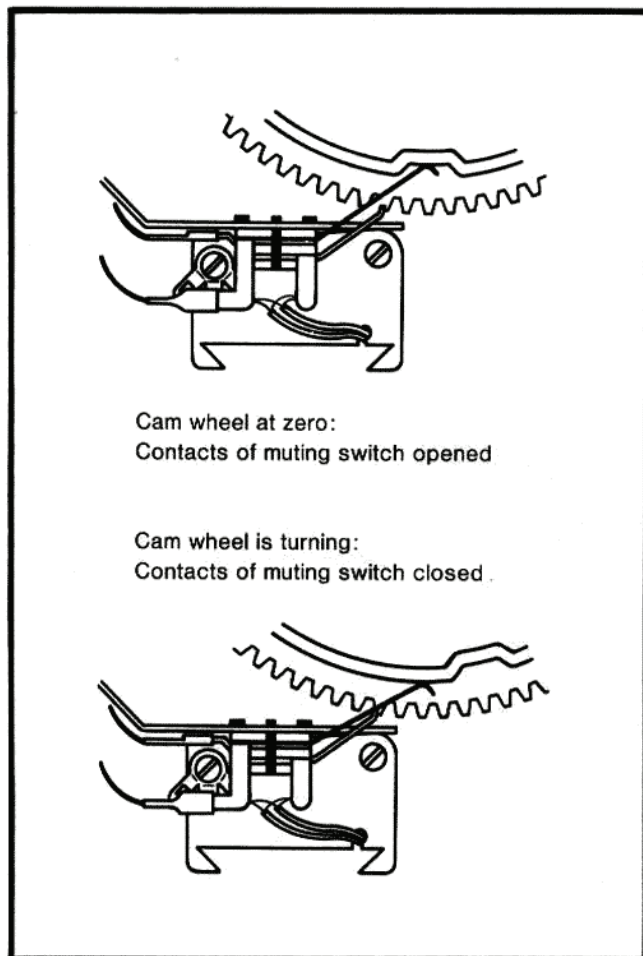

Manual start

When the tonearm (15) is swung inward by hand, the pawl on the switch arm drops into a support (8G) on the base plate, holding the switch arm in this position and the idler wheel (135) in contact with the platter. The slide (151) linked with the switch arm actuates the power switch and sets the turntable platter rotating.

On reaching the run-out groove, the tonearm automatically returns to its rest position and the unit shuts itself off. (See shut-off mechanism, next side). However, if the tonearm is lifted off the record manually and returned to the rest, the tabs of the arm segment (242) release the pawl. The torsion spring (172) then returns the switch arm to its initial position, opening the power switch and disengaging the idler wheel.

Stop switching

When the operating lever is moved to "stop", the starting lever (178) is pushed forward. As a result the shut-off linkage comes into contact with the main cam. The swinging lever (226) remains in its stop position.

When the tonearm is on its rest and the operating lever is pushed to "stop", the operating lever must not jam.

Muting switch

To prevent the noises of the change cycle from being sent through the audio system, the apparatus is fitted with a short-circuiting (muting) switch (140). The switch springs (S) for both channels are actuated by the main cam (223). In the tonearm rest position, the muting switch is opened.

Record drop

Insert the appropriate spindle - AW 3 for standard records (7 mm center hole) or AS 12 for 45 rpm records (38 mm center hole).

Record-drop is initiated by the rotation of cam (223), whose cam surface (AK) guides the cam rocker (203), pushing the change actuator stud (182) and releasing a record by means of the automatic spindle. The main cam is designed so that a record can drop only when the tonearm is above the tonearm rest and thus out of the reach of the largest possible record (12" diameter).

Shut-off and change cycle

The dog (M) on the turntable platter gear (PR) and the shut-off lever (217) actuate both the change cycle at the end of the record as well as the shut-off after the last record in a stack is played.

At the end of a record, the tonearm moves towards the center at an accelerated rate due to the increased pitch of the grooves. This motion carries the shut-off lever (217) towards the dog by means of the shut-off slide (244). The eccentric dog pushes the shut-off lever (217) back at each revolution as long as the tonearm advance is only one normal record groove.

The run-out groove with its steeper pitch moves the shut-off lever against the dog with greater force, engaging the shut-off lever (217) and causing the main cam (223) to be driven out of its neutral position by the turntable platter gear.

Fig. 15 Record drop

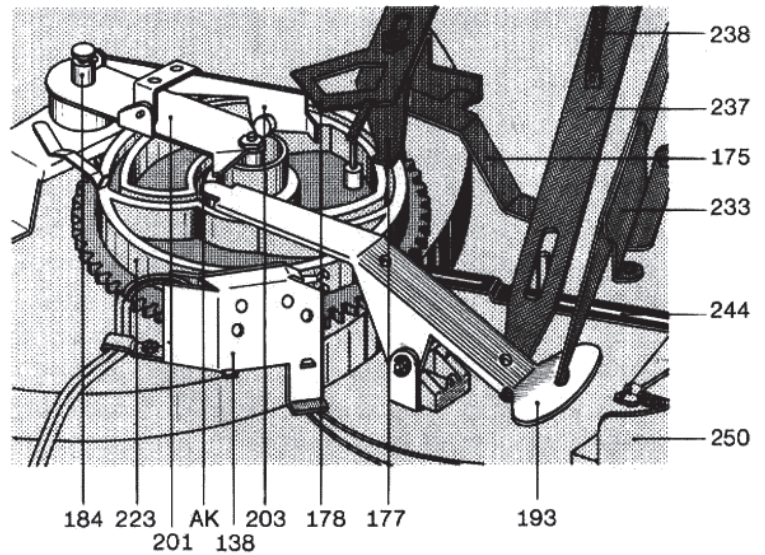

Fig. 16 Actuating "change" or "shut-off"

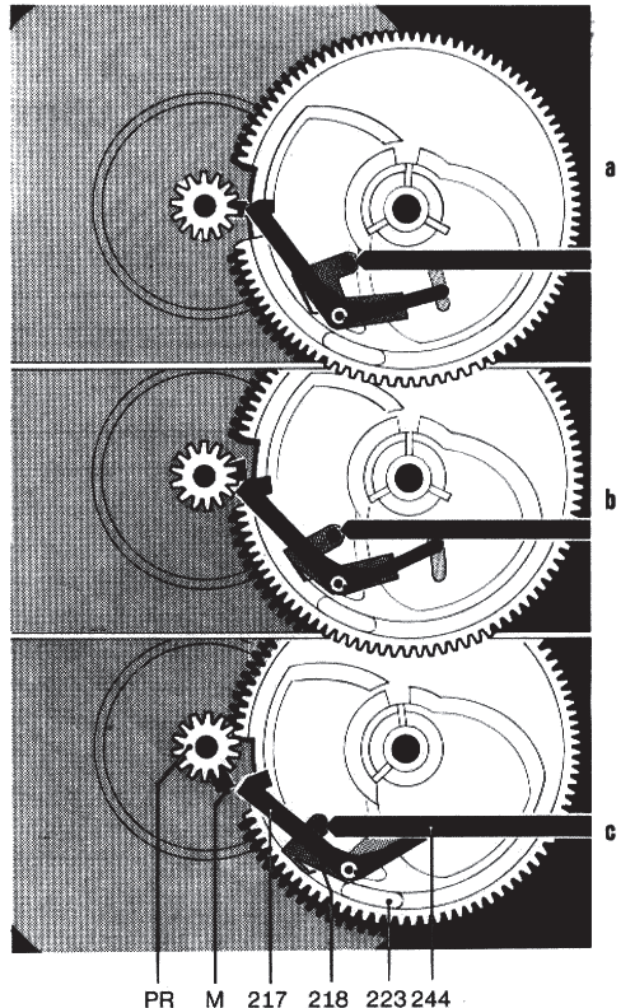

Fig. 17 Change cycle

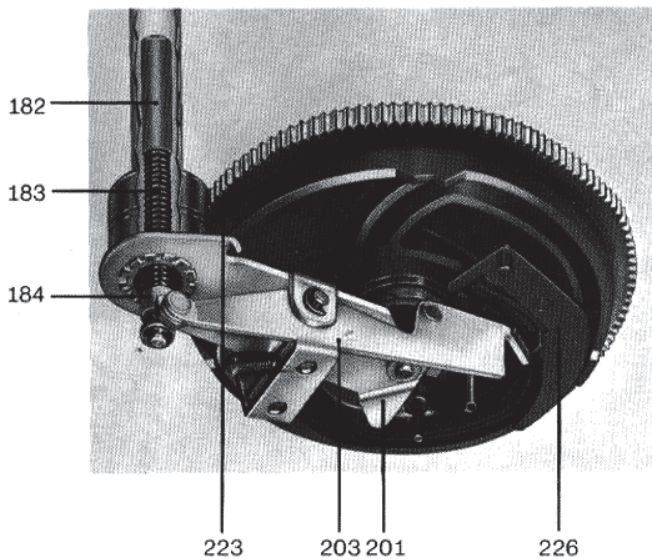

Fig. 18

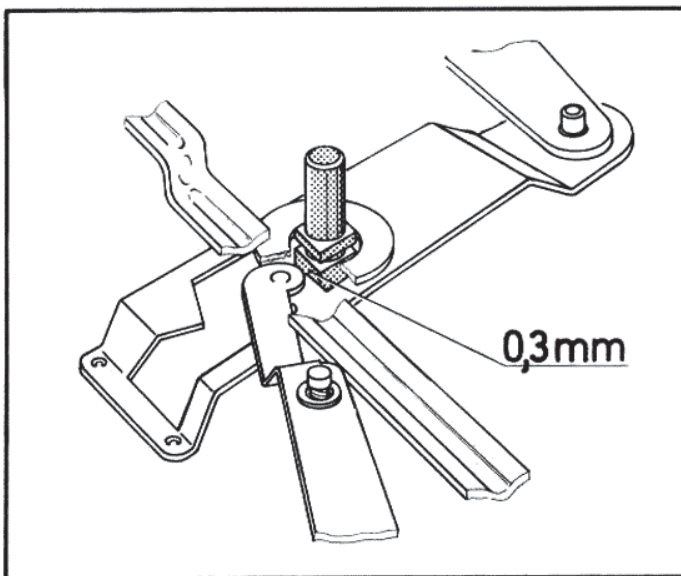
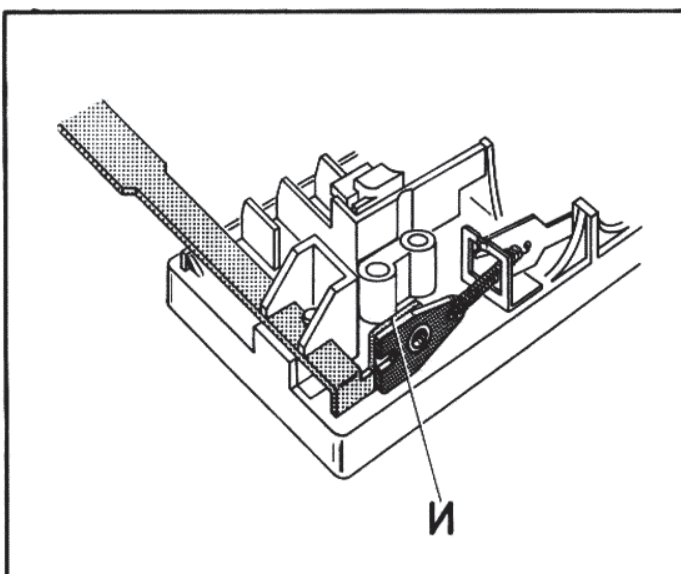

Fig. 19



Shut-off mechanism

Shut-off and change functions are determined by the position of the cam follower lever (226). After every start or record-drop, the cam follower lever is brought to its stop position by the main lever (193) (longer end towards the center of the main cam). As the record is dropped the cam follower lever (226) is turned to its start position by the cam rocker (203), so that the tonearm can swing in toward the record and be lowered on to it. If there are no more records on the spindle, and the cam rocker cannot turn the cam follower lever, the lever remains in its stop position and allows the tonearm to swing to its rest position.

When the main cam (223) returns to its neutral position, the switch arm (175) drops into a cut-out in the main cam, opening the power switch (148) and disengaging the drive idler (135).

Troubleshooting chart

Symptom

Turntable stops after automatic setdown of the tonearm

Cause

- a) Switch arm (175) is not latched by pawl (220)
- b) Power switch opens

Remedy

- a) Loosen screw and turn the short arm piece on the long switch-arm piece. Move the tonearm in and turn the main cam to its neutral position and adjust for about 1/64" play between cam and rectangular bolts riveted into the chassis.
- b) As the tonearm moves in, switch slide (151) must overtravel by about 1/64". Its tab must engage the switch.

Symptom

Last record keeps repeating

Cause

Defective spindle

Remedy

Replace spindle

Symptom

Record does not drop when unit is switched to "start"

Cause

Inadequate engagement between change lever and cam rocker (203)

Remedy

Adjust clearance between change lever and cam rocker to $1/64$ " minimum with apparatus in "start" position.

Fig. 20

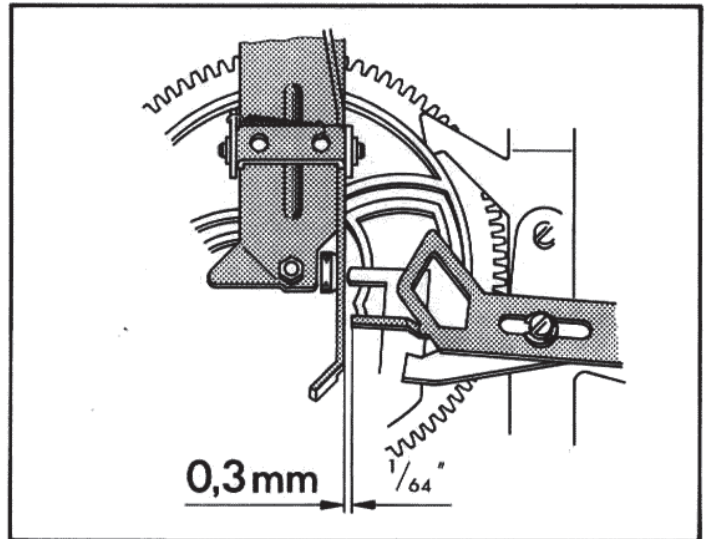

Symptom

Record drops when unit is switched to "stop"

Cause

Cam rocker (203) not caught by start lever

Remedy

Adjust cam rocker so that at the conclusion of the "stop" function the start lever runs about $1/16$ " under the follower.

Fig. 21

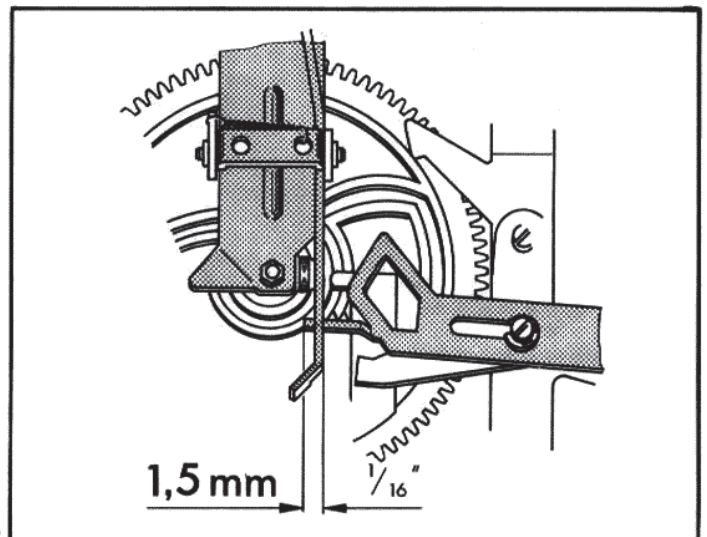

Symptom

Records do not drop

Cause

Cam rocker (203) has too little force (travel)

Remedy

Re-adjust eccentric so that when the three supports in the automatic spindle are held in and the main cam is at its neutral, pressing the change screw moves the support about $1/64$ ".

Fig. 22

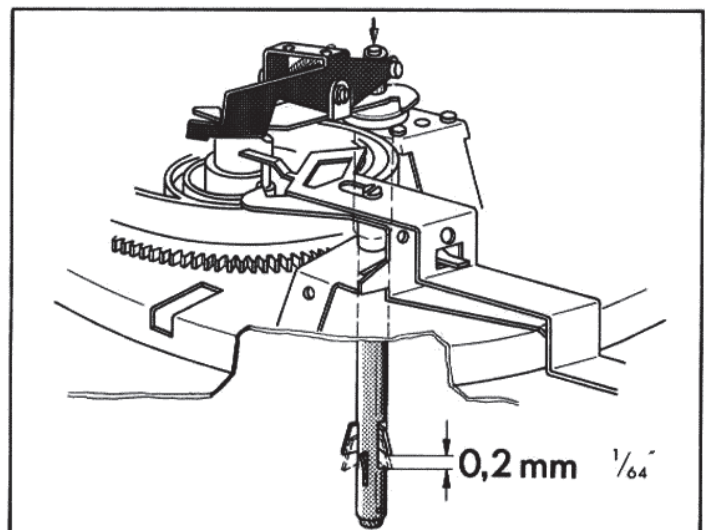
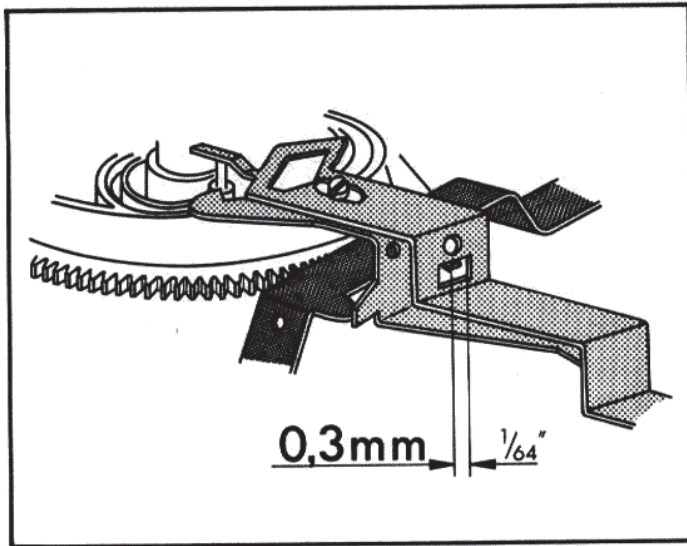

Fig. 23



Symptom

Switch latches into "stop" position when tonearm is at rest.

Cause

Too much clearance between tab on switch arm (175) and start lever (178).

Remedy

Adjust tab on switch arm so that it clears start lever by 1/64" when main cam is in neutral position.

Troubleshooting chart

Symptom	Cause	Remedy
Tonearm moves with stylus force and anti-skating force at zero: a) outward; b) inward	a) Anti-skating out of adjustment b) Too-taut tonearm leads produce a twisting force	a) Adjust spring lever so that horizontal movement of tonearm causes no movement of anti-skating spring. b) Allow some slack in tonearm leads
During change, stop and start operations, noises from the mechanism can be heard in system speaker	Muting switch misadjusted. Distance between contact springs and shorting contact is too great	Bend contacts so that, in the neutral position of the main cam the spacing between contacts is about 0.02 inch. Clean contacts.
No sound	Spacing too small	See above
Motor will not shut off when tonearm is on arm rest	Capacitor across power switch is shorted	Replace capacitor (0.1 μ F, 700 V)
Acoustic feedback	a) Chassis parts (for example leads) are touching base cut-out b) Connecting cables are too taut	a) Correct cut-out according to instructions supplied with unit. Move cables. b) Allow more slack in cables

Spare parts

Ref. No.	Part. No.	Description	Quantity
1	215 470	Automatic spindle AS 12	1
2	213 895	Changing spindle AW 3	1
3	201 452	Facing ring 170 mm \varnothing	1
4	218 667	Turntable mat assembly complete, with facing ring 170 mm \varnothing	1
5	218 662	Turntable complete, with turntable mat and facing ring 170 mm \varnothing	1
	218 666	Turntable assembly 270 mm \varnothing with turntable mat and facing ring 170 mm \varnothing	1
6	219 952	Speed change lever, left	1
7	219 965	Speed regulator knob	1
8	220 975	Blind (cm)	1
	220 974	Blind (inch)	1
9	220 983	Chassis complete	1
10	214 210	Shipping screw assembly	1
11	220 213	Centering disc	1
12	200 709	Single play spindle	1
13	214 054	Washer	1
14	200 543	Retaining ring	1
15	220 976	Tonearm complete	1
16	220 981	Tonearm rest assembly	1
17	210 362	Hex nut BM 3	1
18	201 132	Lift	1
19	210 182	Bowed lockwasher	1
20	210 630	Washer 4,2/8/0,5 St	1
21	210 197	"C" clip 4 x 0,8	2
22	215 430	Cartridge mount TK 14	1
23	219 954	Change lever right	2
24	219 954	Change lever right	2
25	210 816	Machine screw M 4 x 4	2
26	210 816	Machine screw M 4 x 4	2
27	210 366	Hex nut BM 4	5
28	210 362	Hex nut BM 3	2
29	200 579	Spring mounted footing (1 set = 3 pieces)	1
30	210 366	Hex nut BM 4	5
31	200 721	Bushing isolation mount	3
32	200 728	Compression spring	3
33	200 723	Rubber insert isolation mount	3
34	200 722	Steel cup	3
35	210 624	Washer 4.2/7/0.3 St	4
36	201 632	Rubber washer	2
37	200 713	Washer	2
38	200 712	Spring cup	2
39	200 711	Lockwasher	2
40	210 624	Washer 4.2/7/0.3 St	4
41	200 718	Compression spring	2
42	214 217	Contact block	1
43	217 706	Isolation foil	1
44	217 438	Threaded pin	1
45	200 829	Stop nut	1
46	218 636	Set screw	1
47	207 839	Damping ring	1
48	210 146	"C" ring 3.2	3
49	216 881	Arm lift lever, complete	1
50	210 353	Hex nut BM 2	1
51	213 260	Pin 2 x 6	4
52	217 905	Damping piece	1
53	214 047	Special screw (pierced)	2
	214 211	Special screw (threaded)	2
54	220 980	Counterbalance	1
55	220 274	Threaded piece	1
56	220 273	Pression device	1
57	220 329	Support	1
58	215 346	Spring barrel, complete	1
59	215 218	Lever	1
60	219 998	Lever and stud piece	1
61	210 199	"C" clip 6 x 1	1
62	215 221	Cam wheel, small	1
63	215 249	Torsion spring	1
64	220 979	Main lever bracket assembly	1
65	218 906	Indicator	1
66	219 092	Bearing screw assembly	1
67	215 241	Spring lever	1
68	210 220	Threaded pin M 2.6 x 3.5	2
69	200 567	Bearing race with balls	2
70	216 310	Bearing housing	1
71	200 567	Bearing race with balls	2

Fig. 24 Exploded view, parts above chassis

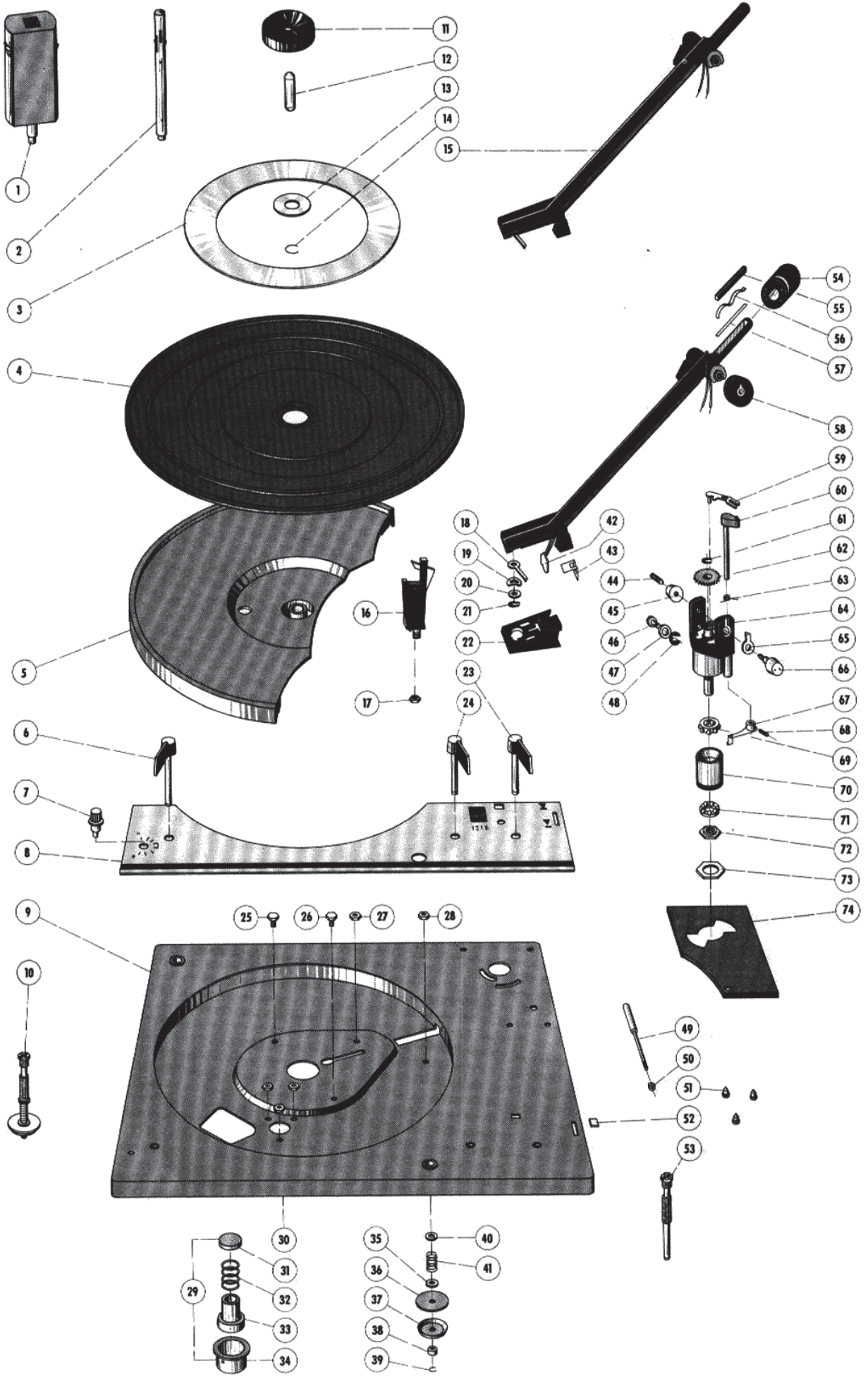
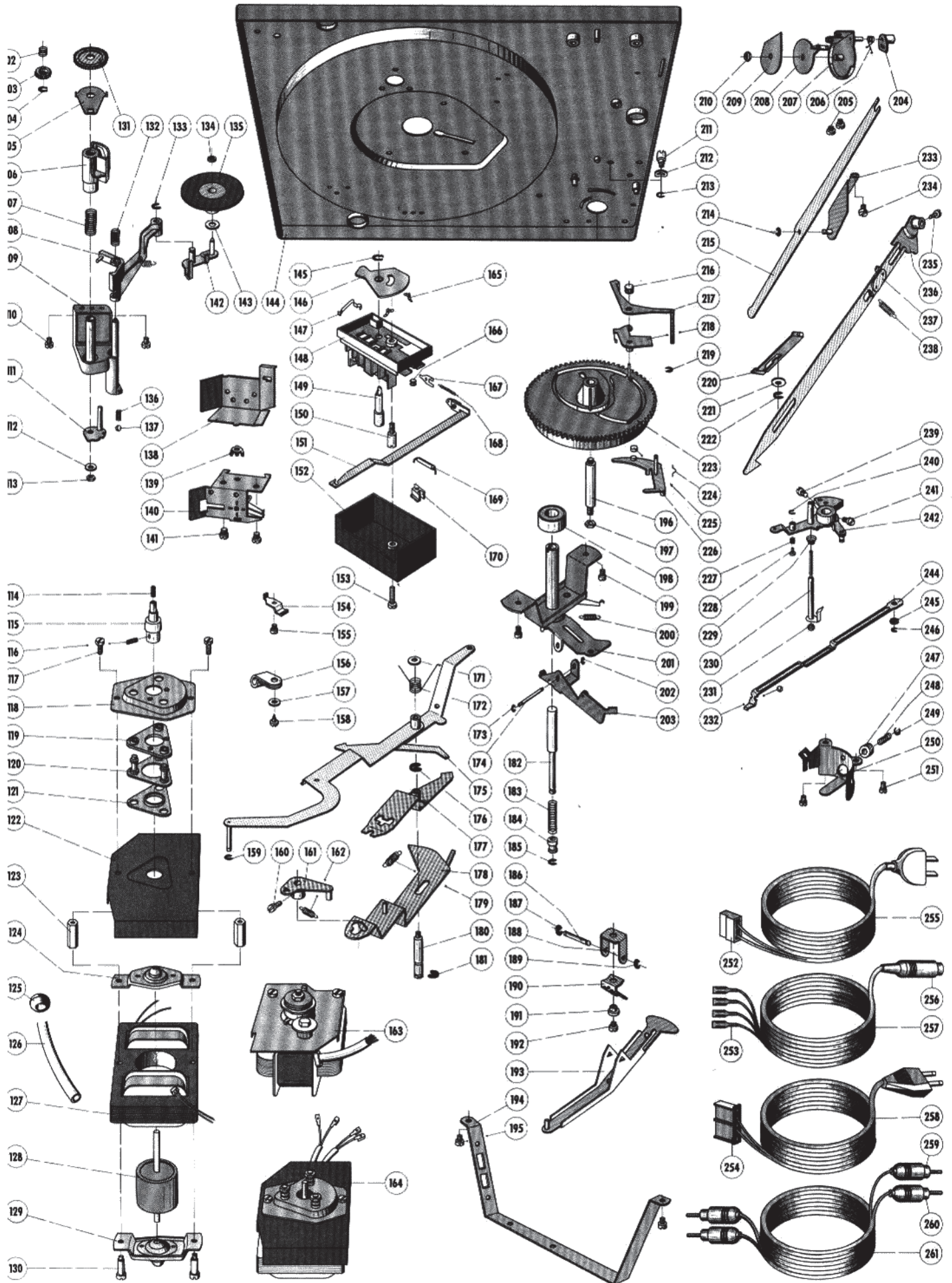

Fig. 25 Exploded view, parts below chassis



Ref.No.	Part. No.	Description	Quantity
72	201 149	Set nut	1
73	200 685	Nut	1
74	220 982	Dress-up plate	1
102	217 376	Compression spring	1
103	217 026	Cam wheel	1
104	210 197	"C" clip 4 x 0.8	2
105	217 233	Speed regulator detent	1
106	217 028	Switching segment	1
107	216 736	Compression spring	1
108	217 234	Switch lever assembly	1
109	216 558	Support assembly	1
110	210 475	Machine screw AM 3 x 5	10
111	217 239	Groove detent	1
112	210 642	Washer	1
113	210 361	Hex nut M 3	1
114	217 751	Threaded pin M 2.6 x 8	1
115	220 970	Motor pulley 50 cycle	1
	220 971	Motor pulley 60 cycle	1
116	210 220	Threaded pin M 2.6 x 3.5	2
117	210 509	Machine screw AM 3.5 x 8	2
118	204 669	Dress-up plate	1
119	204 668	Isolation mount plate	1
120	215 846	Mounting bracket assembly	1
121	204 666	Isolation washer lower	1
122	204 665	Motor shield	1
123	200 167	Bearing spacer	2
124	204 686	Motor bearing top	1
125	209 939	Sleeving	1
126	217 727	Isolation sleeve	1
127	217 591	Stator complete 110/220 V	1
	220 196	Stator 150 V	1
128	204 687	Rotor	1
	220 807	Washer 4.5/9/1,2 F	1
129	204 685	Motor bearing lower	1
130	204 468	Screw bolt	2
131	217 027	Speed regulator wheel	1
132	216 737	Compression spring	1
133	210 146	"C" ring 3.2	3
134	200 633	Lockwasher	1
135	217 888	Idler wheel assembly	1
136	218 629	Compression spring	1
137	209 358	Steel ball 4 mm ϕ	2
138	201 240	Shield	1
139	211 614	Solder lug	1
140	207 447	Muting switch	1
141	210 475	Machine screw AM 3 x 5	10
142	217 244	Idler arm assembly	1
143	200 110	Washer	1
144	220 983	Chassis, complete	1
145	210 196	"C" clip 3	1
146	214 174	Contact support	1
147	214 176	Screen spring	1
148	217 060	Switch plate with voltage selector	1
	214 206	Switch plate less voltage selector	1
	217 059	Switch assembly with voltage selector	1
	214 205	Switch assembly less voltage selector	1
149	214 173	Spindle	1
150	214 181	Screw bolt	1
151	213 970	Switch slide complete	1
152	217 062	Switch cover for switch plate with voltage selector	1
	214 207	Switch cover for switch plate less voltage selector	1
153	210 492	Machine screw AM 3 x 15	1
154	200 447	Cable clamp	1
155	210 475	Machine screw AM 3 x 5	10
156	220 152	Plastic clamp	1
157	210 586	Washer 3.2/7/0.5 St	3
158	210 475	Machine screw AM 3 x 5	10
159	210 145	"C" ring 2.3	10
160	218 583	Machine screw AM 3 x 4	2
161	216 773	Manual/auto selector lever assembly	1
162	216 777	Tension spring	1
163	217 585	2-pole motor 110/220 V, complete	1
	220 199	2-pole motor 150 V, complete	1
164	220 973	4-pole motor 110/220 V, complete	1
	220 972	4-pole motor 150 V, complete	1
165	214 175	Contact spring	2
166	218 986	Roller for switch slide	1

Ref.No.	Part. No.	Description	Quantity
167	213 966	Snap spring	1
168	213 968	Tension spring	1
169	203 725	Capacitor 0.1 μ F, 700 V	1
170	213 978	Locking device, small	1
	213 979	Locking device, large	1
171	210 586	Washer 3.2/7/0.5 St	3
172	213 940	Torsion spring	1
173	210 145	"C" ring 2.3	10
174	217 813	Shaft	1
175	217 889	Switch arm, complete	1
176	210 147	"C" ring 4	3
177	218 538	Switch lever complete	1
178	217 258	Start lever	1
179	200 103	Tension spring	1
180	217 334	Grooved shaft	1
181	210 147	"C" ring 4	3
182	213 918	Change actuator complete	1
183	213 920	Compression spring	1
184	213 921	Bushing	1
185	210 145	"C" ring 2.3	10
186	200 528	Shaft	1
187	210 145	"C" ring 2.3	10
188	201 185	Main lever bracket	1
189	210 145	"C" ring 2.3	10
190	201 186	Leaf spring	1
191	200 458	Spacer	1
192	210 480	Machine screw AM 3 x 6	2
193	201 094	Main lever complete	1
194	217 617	Stand	1
	217 759	Stand with phono jacks	1
195	210 475	Machine screw AM 3 x 5	10
196	200 519	Bearing post for cam wheel	1
197	210 369	Hex nut M 5	1
198	200 554	Ball bearing assembly	1
199	210 472	Machine screw AM 3 x 4	2
200	213 925	Tension spring	1
201	214 201	Bearing support assembly	1
202	210 145	"C" ring 2.3	10
203	213 922	Cam rocker	1
204	217 293	Drive cam assembly	1
205	210 469	Machine screw AM 3 x 3	2
206	217 296	Torsion spring	1
207	217 286	Support bracket assembly	1
208	217 290	Drive washer	1
209	201 195	Cover washer	1
210	210 366	Hex nut BM 4	5
211	220 167	Set screw	1
212	210 187	Bowed lockwasher	1
213	210 147	"C" ring 4	3
214	210 145	"C" ring 2.3	10
215	217 300	Connecting lever	1
216	220 235	Stop nut	1
217	220 232	Shut-off lever	1
218	200 557	Friction plate	1
219	210 145	"C" ring 2.3	10
220	213 942	Latch complete	1
221	202 043	Washer	1
222	210 146	"C" ring 3.2	3
223	220 332	Cam wheel complete	1
224	200 522	Snap spring	1
225	200 650	Sleeve	1
226	214 203	Cam follower lever complete with sleeve	1
227	201 174	Compression spring	1
228	200 686	Spring pin	1
229	201 179	Conical spring	1
230	218 703	Lift rod	1
231	200 527	Shaft pin	1
232	209 358	Steel ball 4 mm ϕ	2
233	217 297	Main lever bracket complete	1
234	210 511	Machine screw AM 4 x 4	1
235	218 583	Machine screw AM 3 x 4	2
236	217 264	Record size selector lever assembly	1
237	217 276	Arm positioning slide assembly	1
238	200 453	Tension spring	1
239	210 482	Machine screw AM 3 x 6	1
240	210 143	"C" ring 1.5	1
241	210 480	Machine screw AM 3 x 6	2
242	215 348	Segment complete	1

Ref.No.	Part. No.	Description	Quantity
244	200 688	Shut-off slide	1
245	201 187	Friction disc	1
246	210 145	"C" ring 2.3	10
247	201 182	Threaded bushing	1
248	218 591	Tension spring	1
249	201 184	Record size selector disc	1
250	219 958	Spring support	1
251	210 475	Machine screw AM 3 x 5	10
252	209 457	Inner casing for AMP - plug	1
253	209 436	Flat prong socket	4
254	213 980	Input jack housing	1
255	207 311	Power cord, U.S. type plugs	1
	213 984	Power cord, with U.S. type plug and 5-pole Dual plug	1
256	209 424	Miniature plug	1
257	207 303	Plug-in output cable	1
258	220 142	Power cord	1
259	209 425	Phono plug, yellow	2
260	209 426	Phono plug, red	2
261	207 299	Audio cable, phono connector	1
**	214 120	Mounting hardware for cartridge	1
**	209 967	Solderlug	1
**	217 839	Bracket	1
**	214 219	Packing carton complete	1
**	211 473	Stroboscope disc	1
**	219 983	Mounting instructions	1
**	219 984	Operating instructions	1
**	220 932	Operating instructions, english	1
**	220 861	Operating instructions, UAP	1

** Not Illustrated

Alterations reserved

Spare parts for units with 2-pole motor

Ref.No.	Part. No.	Description	Quantity
262	210 369	Hex nut M 5	1
263	204 608	Washer	1
264	204 606	Rubber washer	1
265	204 607	Washer	1
266	202 042	Spacer	1
267	210 507	Machine screw AM 3.5 x 6	2
268	204 372	Mounting plate	1
269	204 594	Holding disc	1
270	204 476	Motor spacer	2
271	204 686	Motor bearing top	1
272	220 807	Washer 4.5/9/1.2 F	1
273	220 461	Rotor assembly	1
274	217 593	Stator assembly 110/220 V	1
	220 200	Stator assembly 150 V	1
275	210 522	Machine screw AM 4 x 18	2
276	204 685	Motor bearing lower	1
277	204 468	Motor bearing housing screw	2
278	212 135	Motor pulley 50 cycle	1
	212 136	Motor pulley 60 cycle	1
279	210 220	Theaded pin M 2.6 x 3.5	1
280	210 472	Machine screw AM 3 x 4	1
281	210 615	Washer 3.2/20/1.5 St	1
282	210 731	Insulating sleeve	1
283	217 028	Switching segment	1
284	216 736	Compression spring	1
285	216 558	Support assembly	1
286	210 475	Machine screw AM 3 x 5	10
287	218 629	Compression spring	1
288	209 358	Steel ball 4 mm ϕ	2
289	217 239	Groove detent	1
290	210 642	Washer	1
291	210 361	Hex nut M 3	2
292	210 146	"C" ring 3.2	3
293	216 737	Compression spring	1
294	219 987	Switch lever assembly with tension spring	1
295	200 633	Washer	1

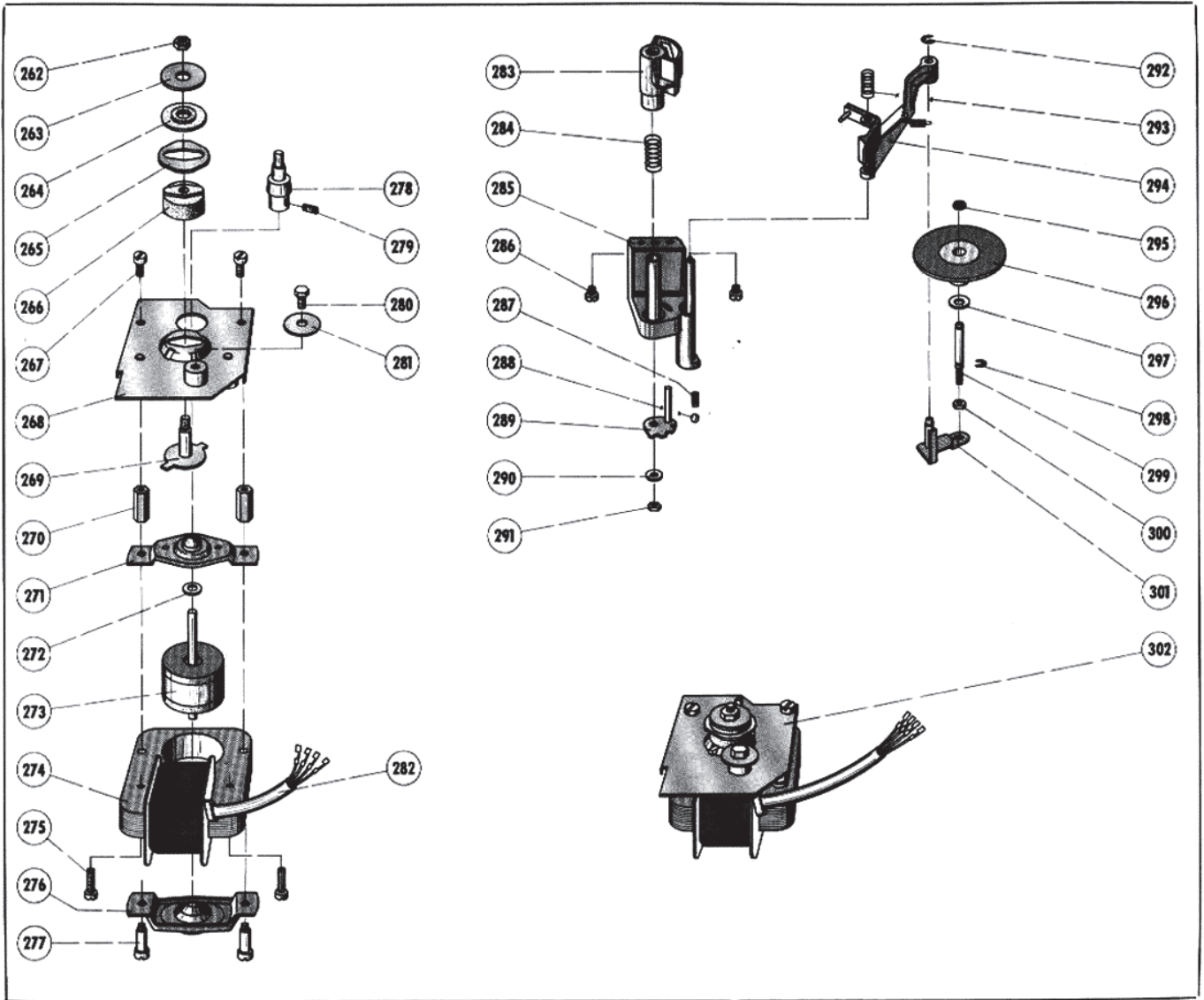

Ref.No.	Part. No.	Description	Quantity
296	217 888	Idler wheel assembly	1
297	200 110	Idler thrust washer	1
298	210 145	"C" ring 2.3	10
299	212 125	Idler wheel shaft	1
300	210 361	Hex-nut M 3	2
301	221 378	Idler arm assembly	1
302	217 585	2-pole motor assembly 110/220 V	1
	220 199	2-pole motor assembly 150 V	1
**	220 165	Stand complete	1
**	221 309	Stand complete with phono jacks	1
**	210 099	Plastic clamp	1
**	210 475	Machine screw AM 3 x 5	10
**	210 586	washer 3.2/7/0.5 St.....	1

** Not illustrated

Alterations reserved

Fig. 26 Chassis, viewed from above

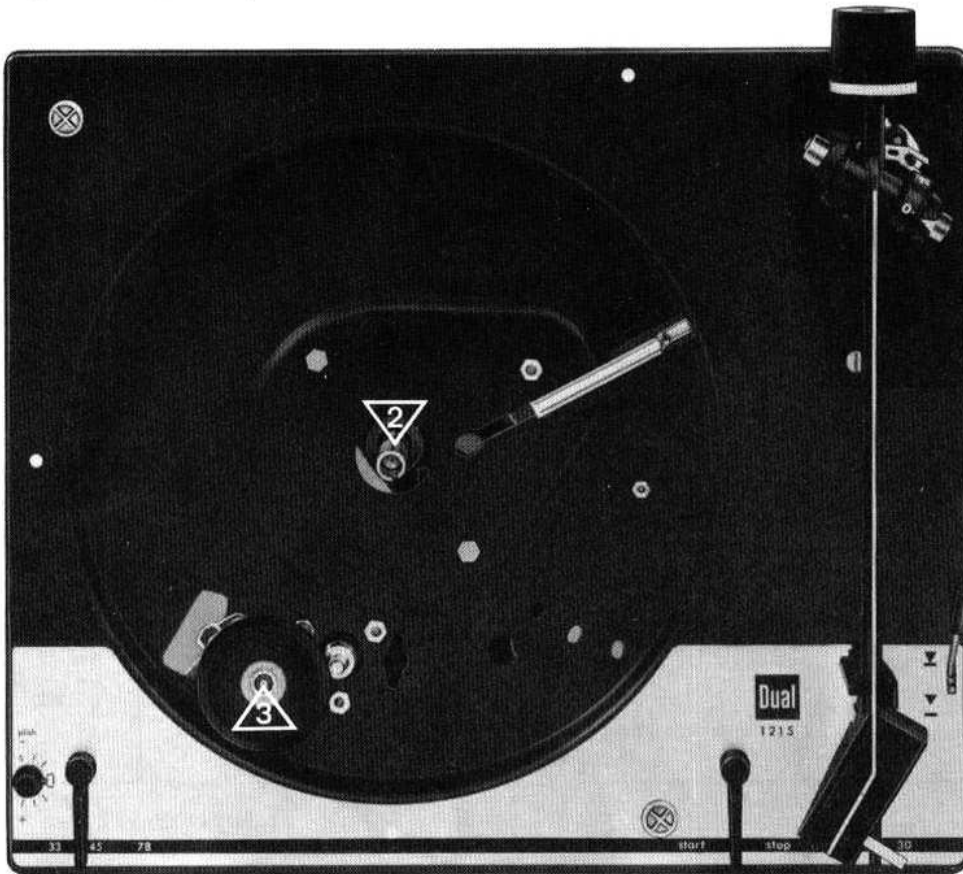

Lubrication

All bearings and sliding points have been properly lubricated during assembly. Re-lubrication is normally not necessary for about two years since all important bearings are provided with oil retainers and sintered bearings.

Lubrication should be applied sparingly. It is of primary importance that no oil or grease should get onto the friction surfaces of the drive wheel, motor pulley or turntable, to avoid slippage. For the same reason, avoid touching these parts.

Use the following lubricants:

Fig. 27 Chassis, viewed from below

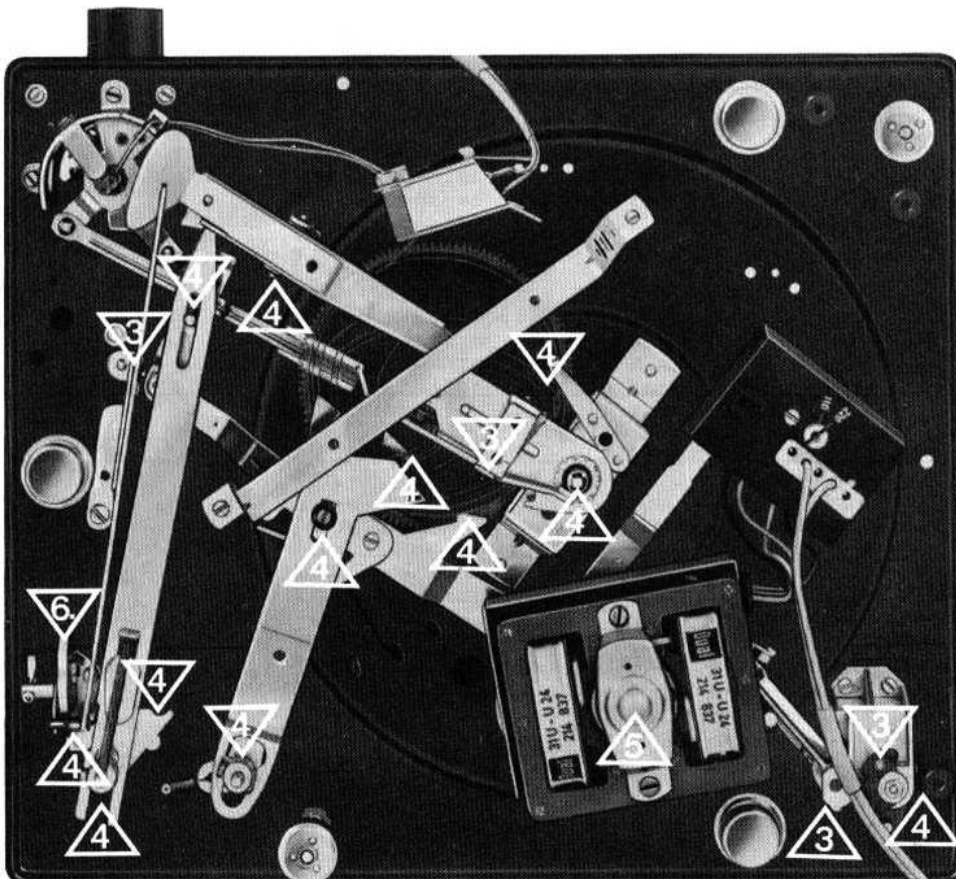

- 2 Adhesive oil, Renotac No. 342
- 3 BP oil, Super Visko-static 10 W/30
- 4 Shell Alvania No. 2
- 5 Isoflex PDP 40
- 6 Wacker siliconoil AK 500 000