

Original

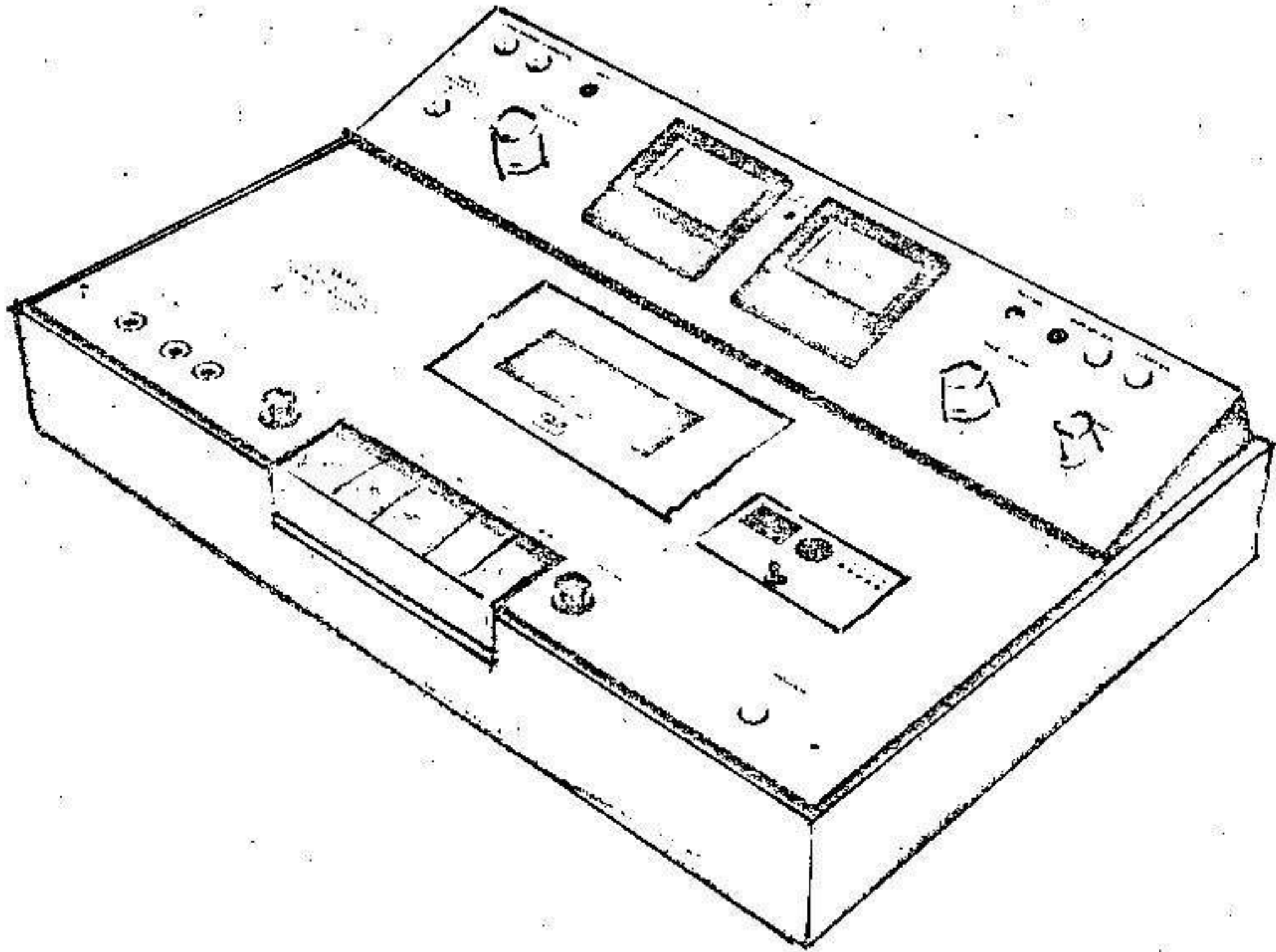

CASSETTE TAPE DECK

MODEL GXC-310D

ALSO APPLICABLE TO MODEL GXC-310

SECTION 1	SERVICE MANUAL	3
SECTION 2	PARTS LIST	21
SECTION 3	SCHEMATIC DIAGRAM	41

I. SPECIFICATIONS

An asterisk next to a figure indicates the minimum guaranteed performance.

TRACK SYSTEM		4 track 2 channel stereo system
TAPE SPEED		*1-7/8 ips. (4.75 cm/sec.) $\pm 2\%$
WOW AND FLUTTER		Less than 0.07% W.R.M.S. *Less than 0.15% R.M.S.
TOTAL WOW AND FLUTTER		*Less than 0.17% R.M.S.
FREQUENCY RESPONSE	LOW NOISE TAPE	30 Hz to 14,000 Hz ± 3 dB *50 Hz to 13,000 Hz ± 4 dB
	CrO ₂ TAPE	30 Hz to 16,000 Hz ± 3 dB *50 Hz to 14,000 Hz ± 4 dB
	Fe-Cr TAPE	30 Hz to 17,000 Hz ± 3 dB *50 Hz to 16,000 Hz ± 4 dB
DISTORTION FACTOR		Less than 1.5%, 1,000 Hz "0" VU
TOTAL DISTORTION FACTOR		*Less than 3%, LOW NOISE TAPE *Less than 5%, CrO ₂ TAPE *Less than 3%, Fe-Cr TAPE
PLAYBACK OUTPUTS	LINE	0.775V (0 ± 1 dB) with 333 Hz "0" VU recorded tape
	DIN	0.55V (-3 ± 1 dB) with 333 Hz "0" VU recorded tape
HEADPHONE OUTPUT		30 mV/8 ohm, with 333 Hz "0" VU recorded tape
POWER OUTPUT		5 Watts per channel GXC-310 only
INPUTS AND IMPEDANCE	MIC	More than 0.5 mV/5 kohm
	LINE	More than 70 mV/100 kohm
	DIN	More than 4 mV/30 kohm
RECORDING PLAYBACK LEVEL	LOW NOISE TAPE	*0 ± 2 dB, 1,000 Hz "0" VU recording
	CrO ₂ TAPE	*-3 ± 1.5 dB, 1,000 Hz "0" VU recording
SIGNAL TO NOISE RATIO		Better than 50 dB *Better than 47 dB
TOTAL SIGNAL TO NOISE RATIO		*Better than 43 dB
CROSS TALK		Better than 25 dB, 1,000 Hz +3 VU recording
ERASE RATIO		Better than 70 dB
PEAK LEVEL INDICATOR		+8 VU ± 1 dB
RECORDING BIAS FREQUENCY		95 ± 5 kHz
BIAS LEAK		Less than -20 VU
RECORDING CAPACITY		90 min. with C-90 cassette tape
F.FWD AND RWD TIME		80 sec. with C-90 cassette tape
HEAD	RECORDING/PLAYBACK HEAD	4 track 2 channel GX recording/playback head Type: P4-341 Gap: 1.7 microns Impedance: 1,000 ohm $\pm 20\%$ at 1 kHz D.C. Resistance: 190 ohm
	ERASE HEAD	2 track 1 channel ferrite erase head Type: E4-165 Gap: Double gap Impedance: 190 ohm $\pm 10\%$ at 60 kHz D.C. Resistance: 2.5 ohm
MOTOR		Hysteresis Synchronous outer rotor motor Type: HMI-12CS Revolutions: 1,500/1,800 r.p.m. at 50/60 Hz

TRANSISTOR AND F.E.T.	2SA628(E)(F) ... 4 2SA640(E)(F) ... 1 2SC4581(G)(C)(D) ... 4 2SC711 (F)(G) ... 1 2SC1175(R)(S)(E) ... 2 GXC-310 only (Main Amp.) 2SB511(D)(E) ... 2 2SC536(F)(G) ... 2	2SC1647(R)(S)(E) ... 16 2SC1648(E)(U) ... 2 2SC1648(R)(S)(E) ... 4 2SD360(D)(E) ... 2 2SK34(D) ... 2 2SC1384(G)(R)(S) ... 2 2SD325 (D)(E) ... 2
DIODE	1N60 ... 4 1N4001 ... 5 1S2473 ... 12 1S2473VE ... 15 GXC-310 only (Main Amp.) VD1213 ... 2	WZ085 ... 1 WZ192 ... 1 SR103D ... 2
POWER REQUIREMENT	110 to 240V A.C. 50/60 Hz, Universal models 100V A.C. 50/60 Hz, JPN models 120V A.C. 60 Hz only, CSA models 220V A.C. 50 Hz only, CEE models 240V A.C. 50 Hz only, BSI models	
POWER CONSUMPTION	GXC-310: 31W, CSA and Universal models GXC-310D: 22W, CSA, CEE and BSI models 20W, Universal models 19W, JPN models	
DIMENSIONS	440(W)×145(H)×300(D)mm (17.3"×5.7"×11.8")	
WEIGHT	GXC-310: 8.7 kg (19.1 lbs.) GXC-310D: 8.6 kg (18.9 lbs.)	

NOTE: Specifications subject to change without notice.

IV. MECHANISM ADJUSTMENT

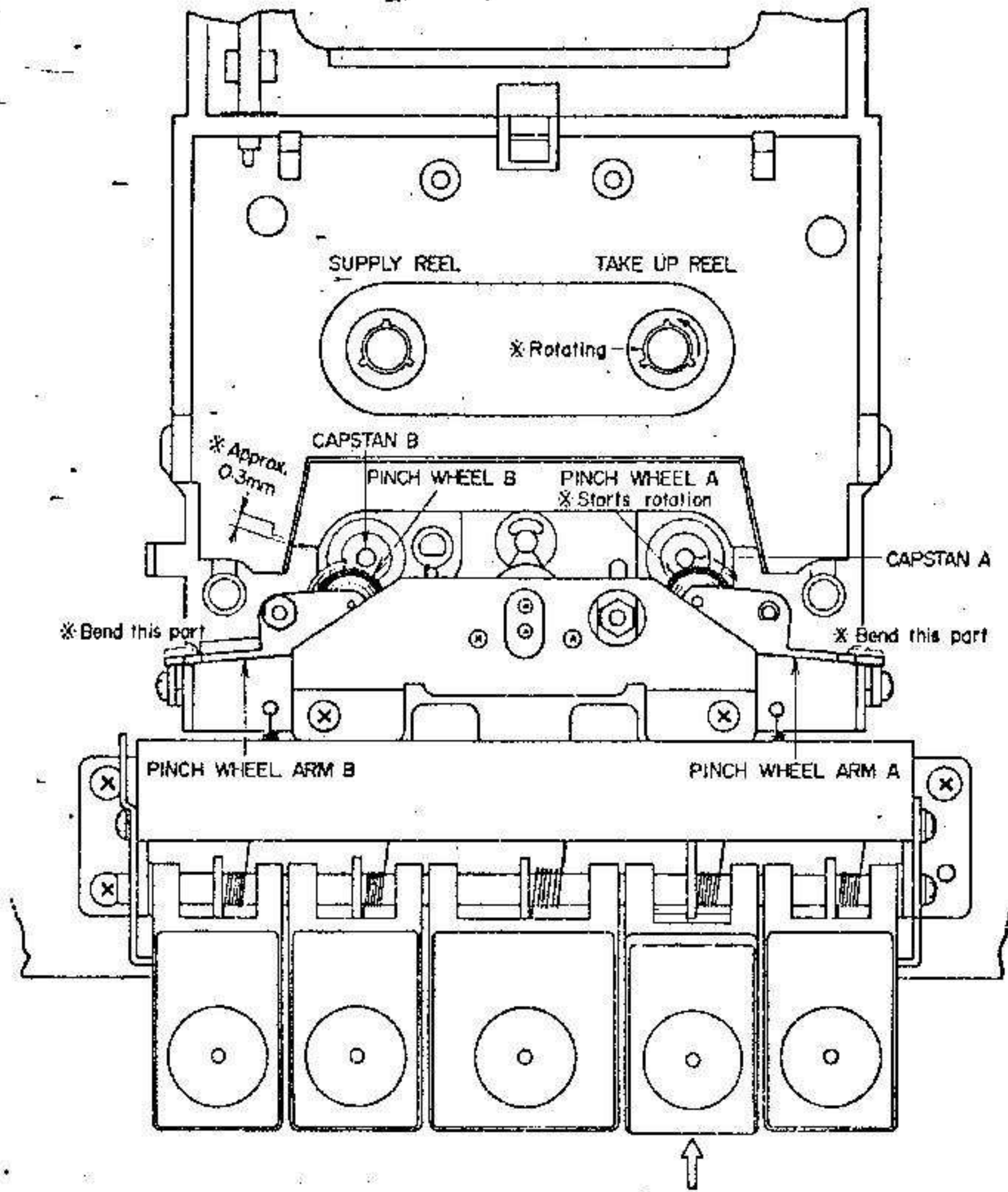

Fig. 1

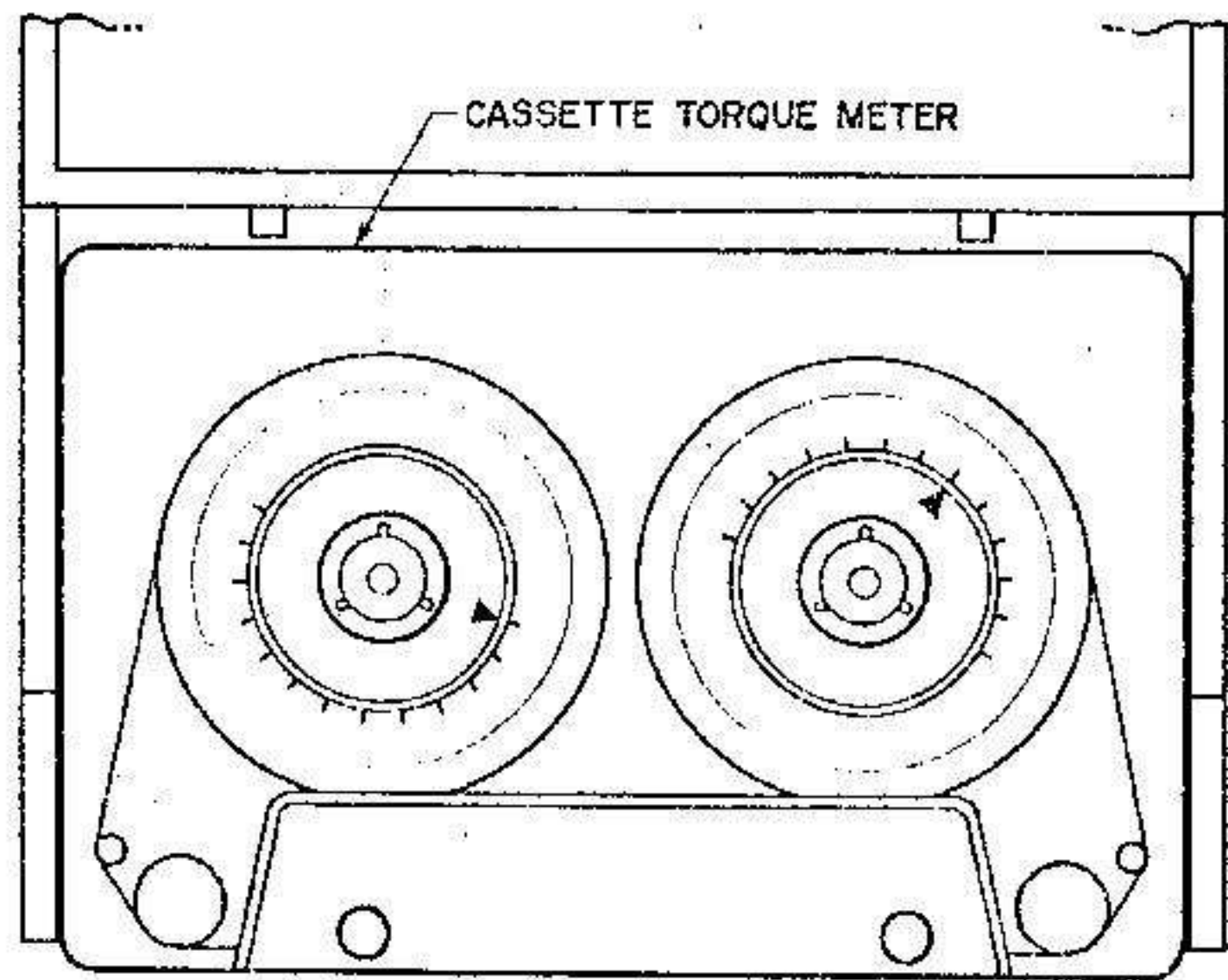

Fig. 2

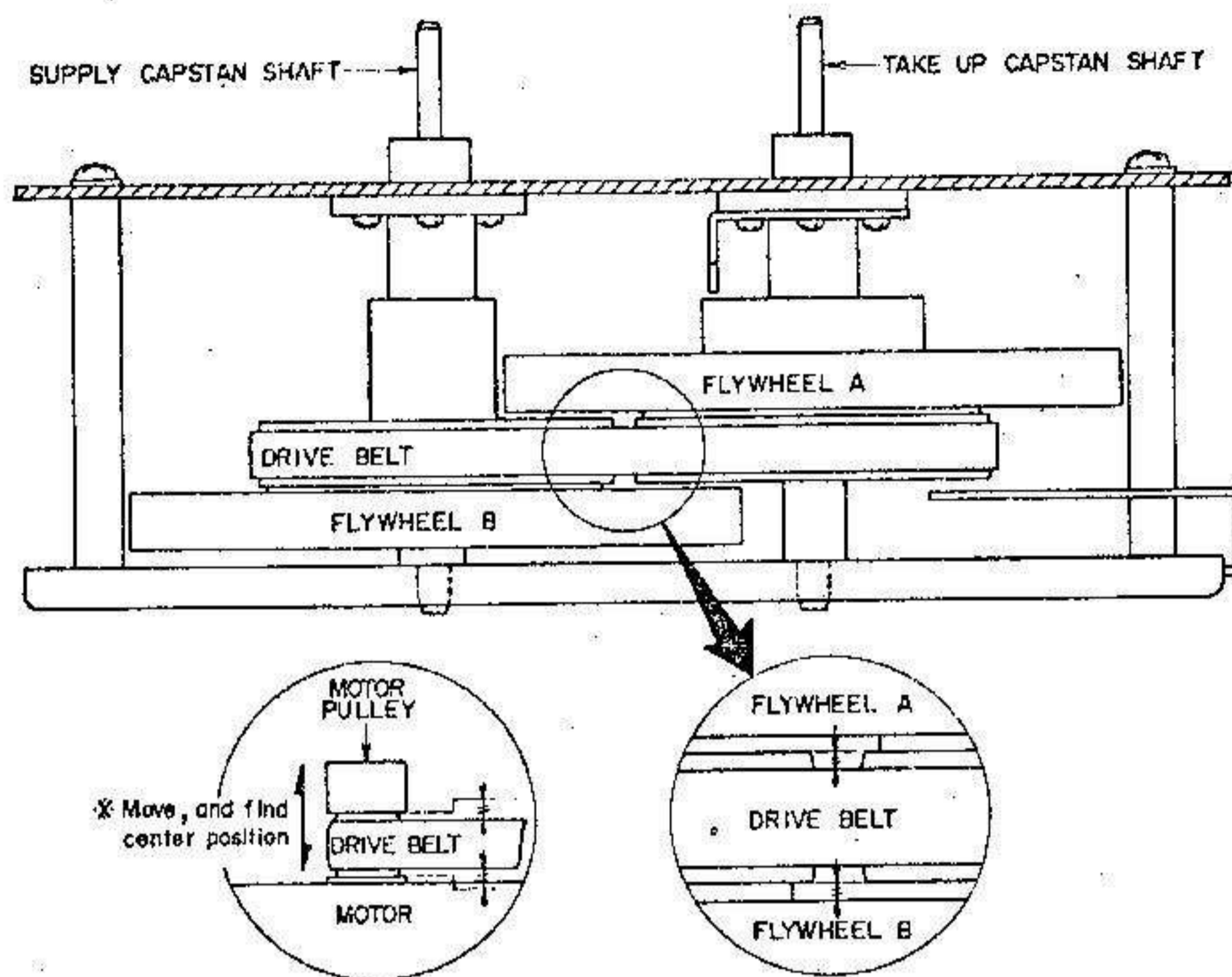

Fig. 3

Flywheel A	Flywheel B	Flywheel A	Flywheel B	Flywheel A	Flywheel B	Flywheel A	Flywheel B
A - A		B - B		C - C		D - D	
A - B		B - C		C - D			
A - C		B - D					

Chart 1

1. PINCH WHEEL A, PINCH WHEEL B ROTATING ORDER ADJUSTMENT

When the play Button is gently depressed, first the take-up reel rotates. Next, pinch wheel A and then pinch wheel B must rotate. Adjust pinch wheel A, and pinch wheel B rotating order and timing by bending the extended parts of pinch wheel arms A and B as shown in Fig. 1.

2. TAKE-UP AND SUPPLY REEL TABLE TORQUE MEASUREMENT

As shown in Fig. 2, use a cassette torque meter and at play mode, measure the reel table torque of both reels during tape travel.

Specified torque:

Take-up reel table: 50 ± 10 gr-cm

Supply reel table: 10 ± 3 gr-cm

3. REWIND AND FAST FORWARD TORQUE MEASUREMENT

Use a cassette torque meter and measure torque at the point at which the tape stops after stop mode is effected from Rewind and Fast Forward mode respectively.

If necessary, adjust by changing winding clutch friction pressure.

Proper rewind and fast forward torque is about 70 gr-cm.

4. MOTOR PULLEY HEIGHT ADJUSTMENT AND FLYWHEEL REPLACEMENT

1. As shown in Fig. 3, the drive belt must run in the center between flywheel A and flywheel B and on the center of the motor pulley.

This adjustment is made by changing the motor pulley height.

2) When replacing flywheel A and flywheel B, because it is necessary for the flywheels to match in order to obtain proper tape tension, one the following combinations must be selected from the 4 types available.

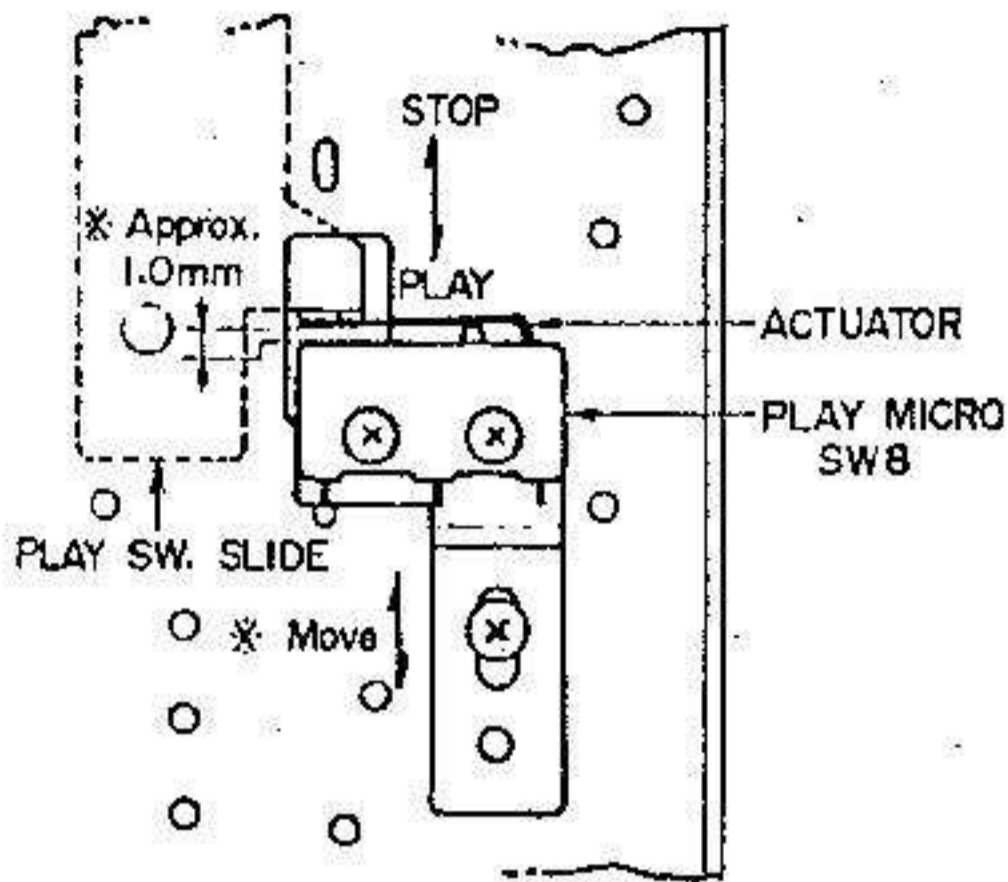

Fig. 4

5. POSITION ADJUSTMENT OF PLAY MICRO SWITCH

Adjust position play micro switch so that when the play button is depressed, the space between the body of the play micro switch and actuator is about 1.0 mm as shown in Fig. 4.

6. POSITION ADJUSTMENT OF RECORDING MICRO SWITCH

Adjust position of recording micro switch so that at recording mode, the space between the body of the recording micro switch and actuator is about 0.5 mm as shown in Fig. 5.

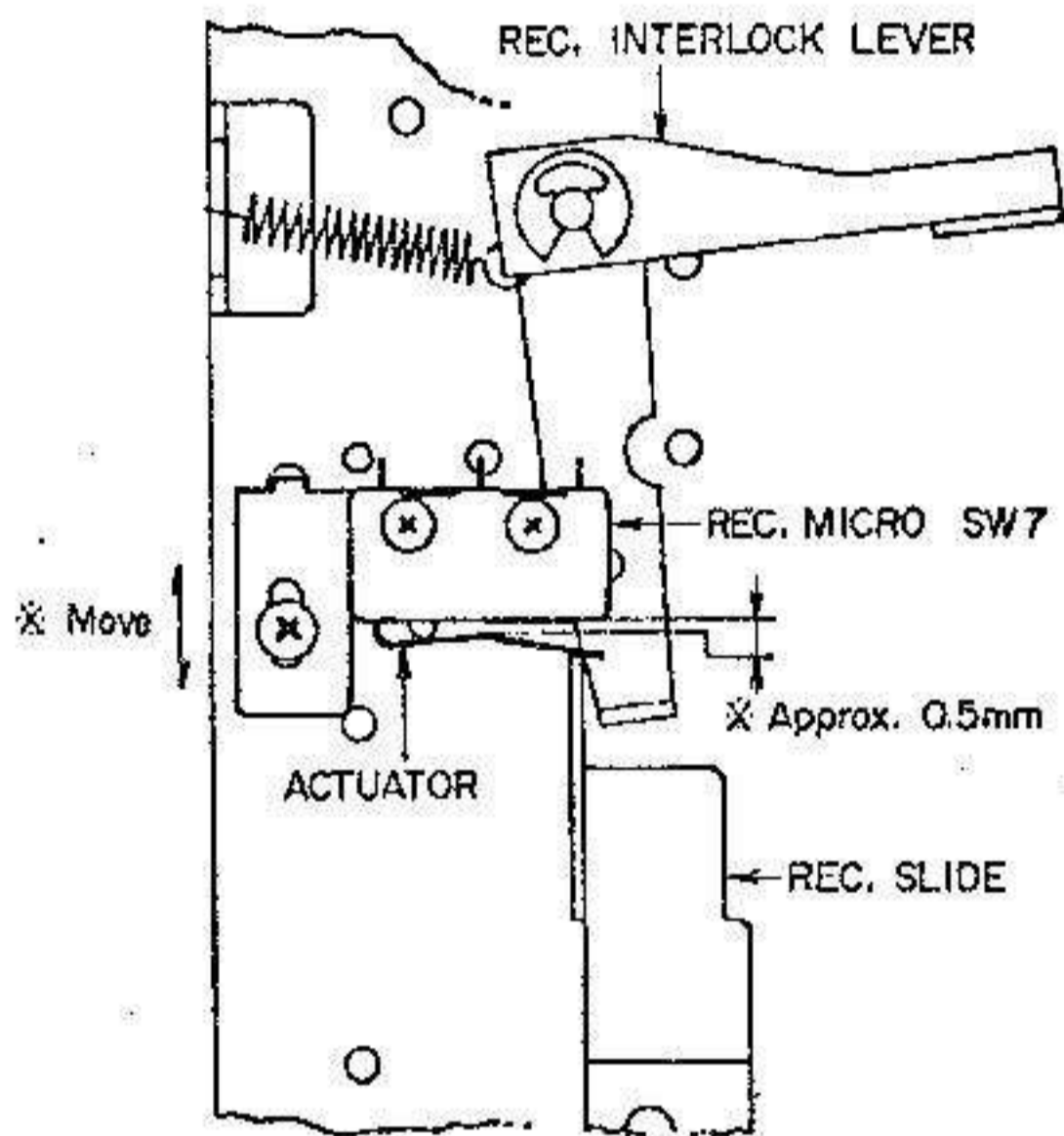

Fig. 5

7. REED SWITCH POSITION ADJUSTMENT

Adjust reed switch position so that the space between the reed switch and Reed Switch P.C. Board is 0.5 mm and the space between the reed switch and magnet is 1 mm as shown in Fig. 6.

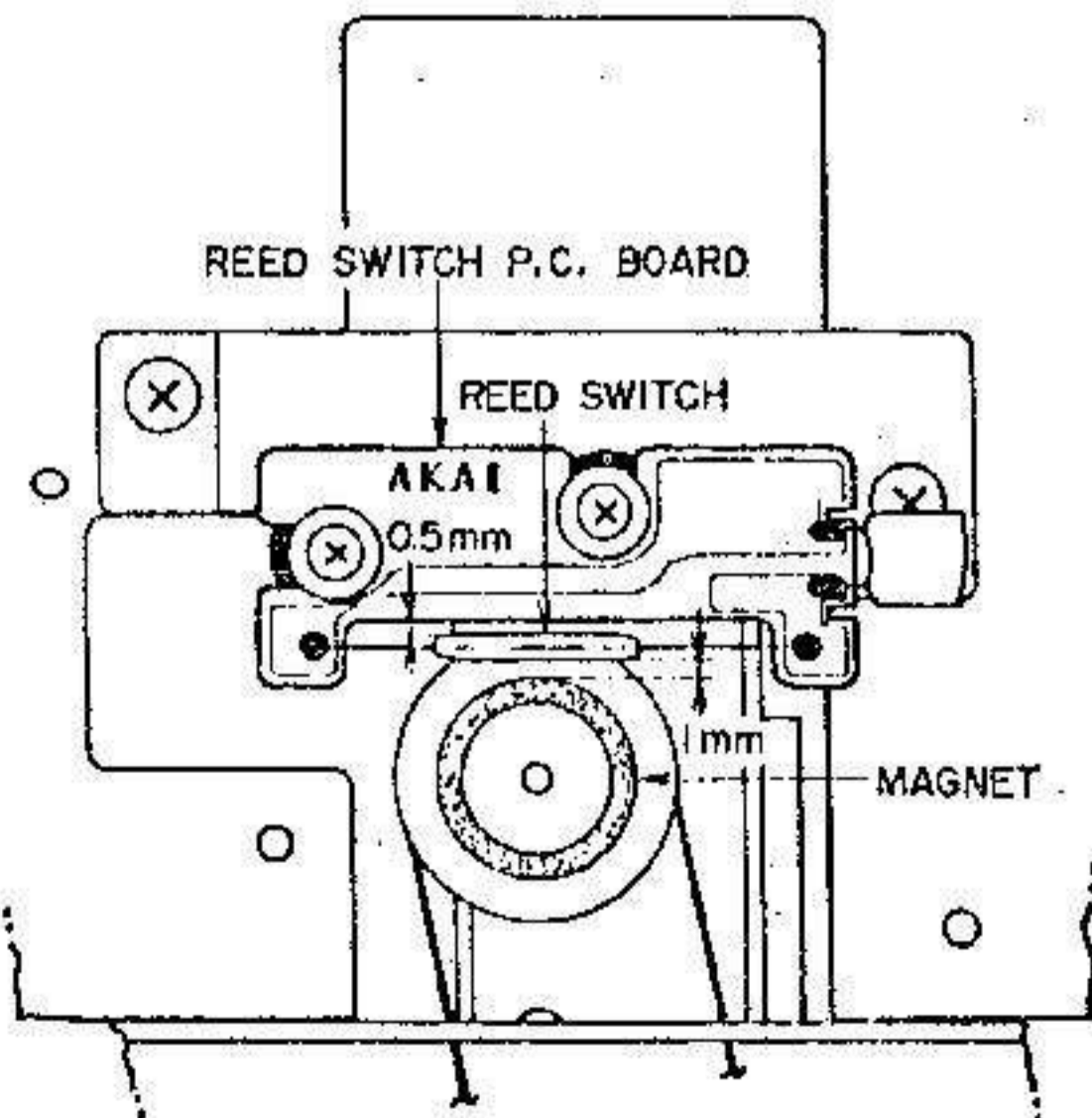

Fig. 6

V. HEAD ADJUSTMENT

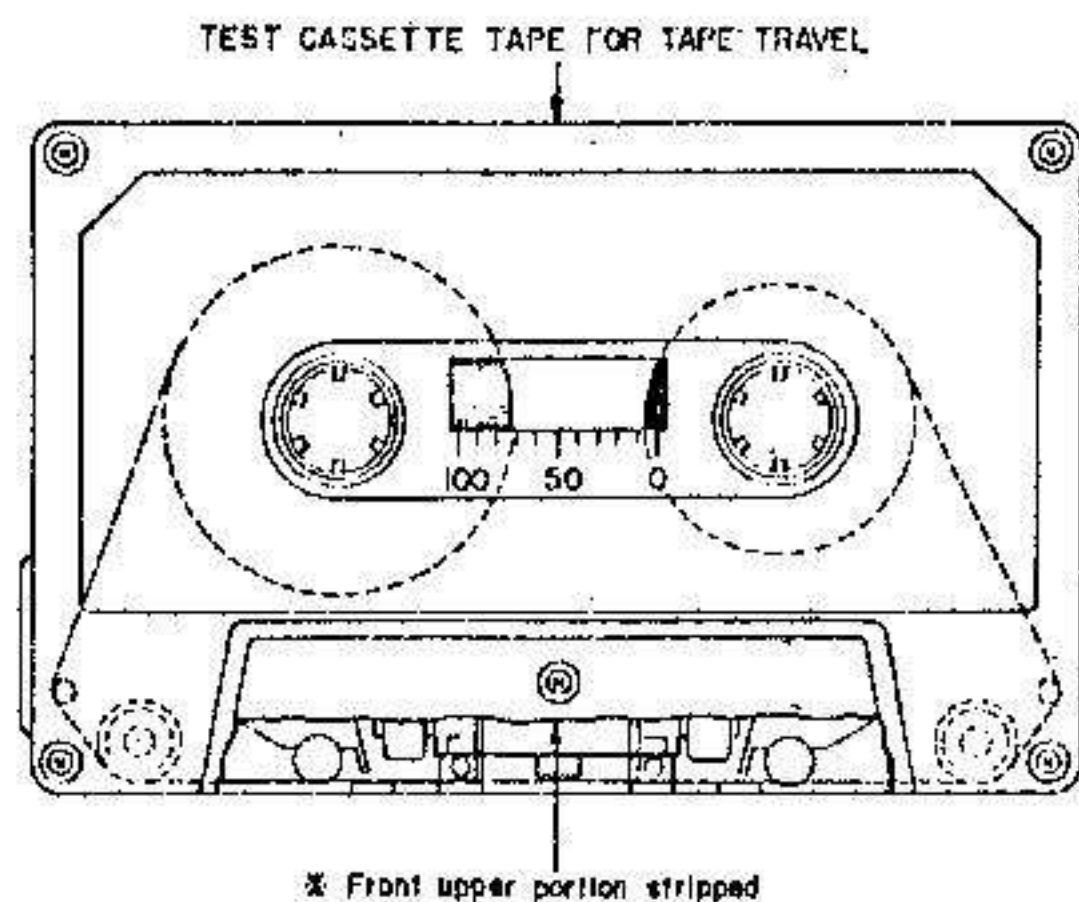

Fig. 7

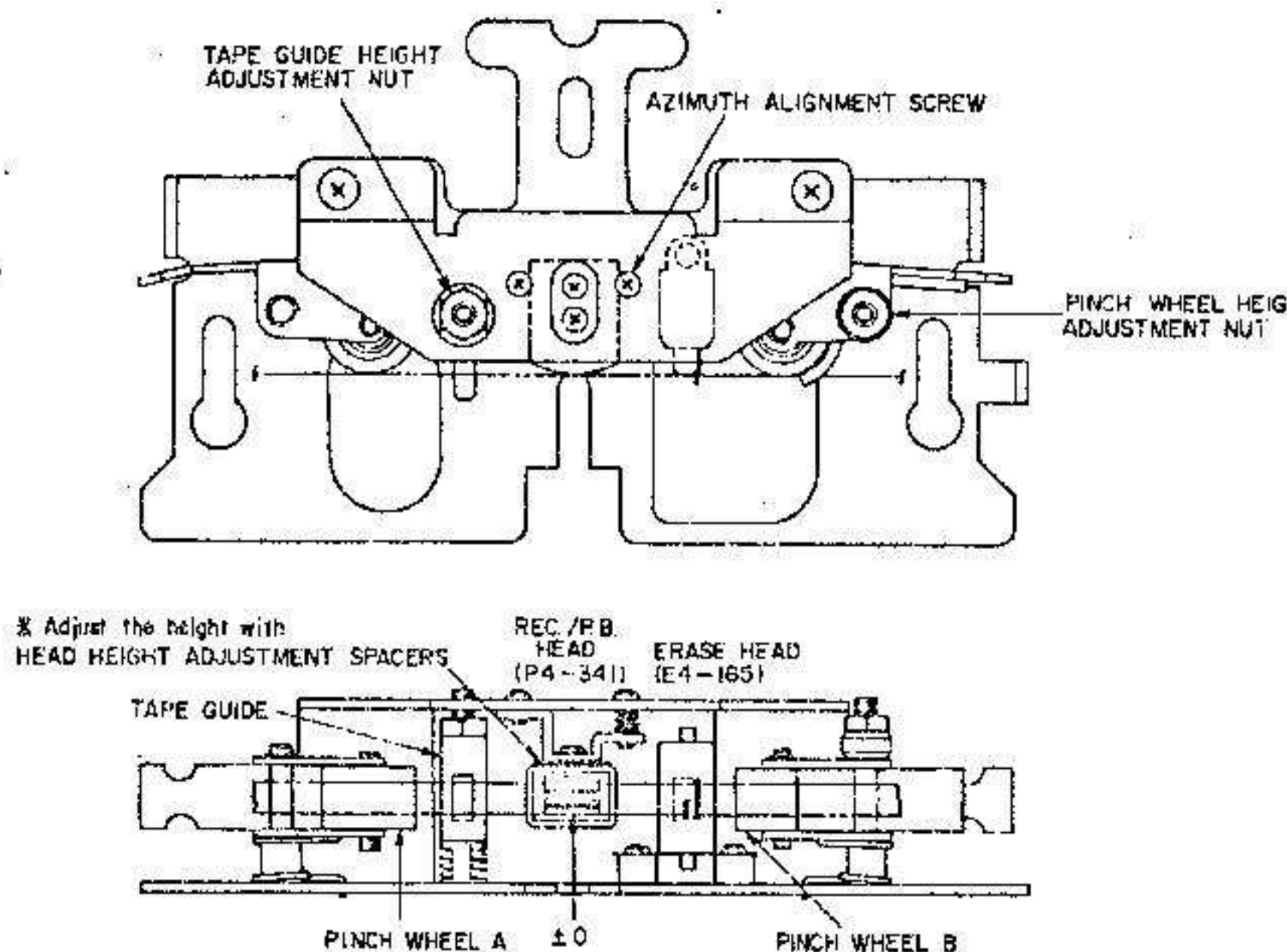

Fig. 8

1. TAPE TRAVEL ADJUSTMENT (Refer to Figs. 7 and 8)

As shown in Fig. 7, use a cassette tape from which the upper part of the cassette case has been stripped off for easy visibility of the head area and, using the erase head as standard for height, adjust tape guide height adjustment nut and pinch wheel B height adjustment nut for proper tape guide and pinch wheel B height and so that the tape runs smoothly and does not twist at the tape guide part of Pinch wheel B. (Fig. 8)

2. RECORDING/PLAYBACK HEAD HEIGHT ADJUSTMENT (Refer to Fig. 8)

Use a 4-track, 1,000 Hz cassette head height adjustment tape, and adjust recording/playback head height with head height adjustment spacer(s). For details, refer to GENERAL OPERATING PRINCIPLES AND ADJUSTMENTS.

3. RECORDING/PLAYBACK HEAD AZIMUTH ADJUSTMENT (Refer to Fig. 8)

- 1) After recording/playback head height adjustment has been completed. Use a 10 kHz azimuth adjustment test tape and adjust recording/playback head azimuth with azimuth alignment screw to obtain maximum output on both channels.
- 2) Recheck recording/playback head height and, if necessary, repeat adjustments outlined in Items 2 and 3-1) above.

NOTES:

- 1) Clean heads prior to head adjustment.
- 2) Be careful not to use a magnetized driver or other magnetized tools in the vicinity of the heads.
- 3) Use only new tape as level variation is likely to occur when using old tape.
- 4) Demagnetize heads with head demagnetizer before and after head adjustment.
- 5) As perfect head adjustments are vital to tape deck or tape recorder performance, be sure that these adjustments are carried out properly.

Step	Adjustment Item	Test Tape Supply Signal	Mode	Adjustment Point	Result	Remarks
1	PLAYBACK LEVEL ADJUSTMENT	333 Hz 0 VU Test Tape	PLAY	VR-1, 1 kB CW-5214	0 ±1 dB	-
2	RECORDING LEVEL ADJUSTMENT (low noise)	Low Noise Tape 1,000 Hz 0 VU recording	REC and PLAY	VR-5, 20 kB CW-5214	0 ±2 dB	Set Tape Selector to LOW NOISE
3	RECORDING LEVEL ADJUSTMENT (chrome)	Chromium Dioxide Tape 1,000 Hz 0 VU recording	REC and PLAY	-	-3 ±1.5 dB	Set Tape Selector to CHROME
4	FREQUENCY RESPONSE ADJUSTMENT	Low Noise Tape (blank) 1,000 Hz 10,000 Hz -20 VU recording	REC and PLAY	VR-6, 300 kB CW-5214	Adjust bias Voltage to obtain: 10,000 Hz is +1 dB higher than 1,000 Hz, Deviation: ±0.5 dB	Re-check recording level Set Tape Selector to LOW NOISE
5	MAIN AMP. IDLING CURRENT ADJUSTMENT	No input signal	STOP	VR-1, 30 kB CG-5810	30 mA, at Fuse Post Terminals	GXC-310 only

Chart 2

NOTES:

1. Tape Selector at Low Noise.
2. Output Volume maximum.
3. New test tape should be used.
4. The letter b following an adjustment parts number indicates "right channel".

VII. DOLBY NR. CIRCUIT ADJUSTMENT

Adjust Dolby NR. Circuit carefully as following procedures in Chart 3.

Step	Item	Supply Signal	Mode	Dolby Switch	T.P.	Adjustment Part	Result B Point Level	Remarks
1	19 kHz Filter	19 kHz Line Input	REC	ON	-	L2 23 mH	Minimum Level	-
2	Recording Dolby Adjustment	5 kHz Line Input	REC	OFF	GND	External Attenuator	+2 dBm	Keep Rec. Level Volume maximum
		5 kHz Line Input	REC	OFF	GND	Reduce Input 30.5 dBm	-28.5 dBm	
		5 kHz Line Input	REC	ON	GND	VR-4 1 kB CW-5214	-18.5 dBm	
		5 kHz Line Input	REC	ON	Disconnect from GND	VR-3 5 kB CW-5214	-20.5 dBm 2 dBm decrease	
3	Playback Dolby Confirmation	5 kHz -28.5 dBm recorded Test Tape	PLAY	OFF	-	-	or Line Out -28.5 dBm	Keep Line Level Volume maximum
		5 kHz -28.5 dBm recorded Test Tape	PLAY	ON	-	-	or Line Out -38.5 dBm	

Chart 3

Connecting Method:

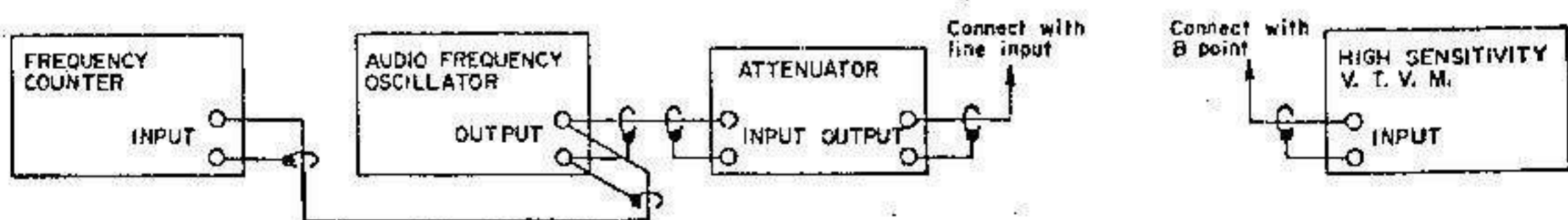

Fig. 10

- NOTE:
1. Because Dolby Noise Reduction Circuit Adjustment is Vital to accurate frequency and level, etc., use only calibrated measuring instruments.
 2. Level deviation must be within ± 0.5 dBm.
 3. Paint lock semi-fixed resistors following adjustment.
 4. To prevent adjustment discrepancy caused by recording bias leakage, disconnect oscillator bias circuit lead wire prior to adjustment.
 5. Refer to Fig. 9.

VIII. D. C. RESISTANCE OF VARIOUS COILS

Part	Designation	D.C. Resistance
MOTOR	HM1-12CS	Between YLW-BLU: 205 ohm Between BLU-RED: 186 ohm Between RED-YLW: 193 ohm
STOP SOLENOID (SL-1)	0730TH71	15 ohm $\pm 10\%$
INDUCTOR (L2)	GE6070A	48 ohm
HEADPHONE OUTPUT TRANSFORMER	S14-123S	Primary: 262 ohm Secondary: 1.8 ohm
OSCILLATOR COIL	OT-925	Between 1 - 3: 0.2 ohm Between 4 - 6: 1.3 ohm Between 7 - 9: 6.1 ohm
ERASE HEAD	*E4-165	2.5 ohm
RECORDING/PLAYBACK HEAD	P4-341	190 ohm

Chart 4

- NOTE:
- The resistance values shown in this chart are average values.
 - E4-165 is interchangeable with E4-160 (GXC-75D)

IX. CLASSIFICATION OF VARIOUS P. C. BOARDS

1. P. C. BOARD INTERCHANGEABILITY CHART

P. C. BOARDS	GXC-310D	GXC-310
PRE AMP. P. C. BOARD	CW-5214	CW-5214
POWER SUPPLY P. C. BOARD	CW-5213	CW-5213
FUSE P. C. BOARD	CH-5311	CH-5311
PEAK LAMP P. C. BOARD	CW-1061	CW-1061
REED SWITCH P. C. BOARD	CG-1229	CG-1229
VU LAMP P. C. BOARD	MY-5015	MY-5015
MAIN AMP. P. C. BOARD	-	CG-5810
VOLUME CONTROL P. C. BOARD	-	CW-5225

Chart 5

2. COMPOSITE VIEWS OF COMPONENTS

1) PRE AMP. P.C. BOARD (CW-5214)

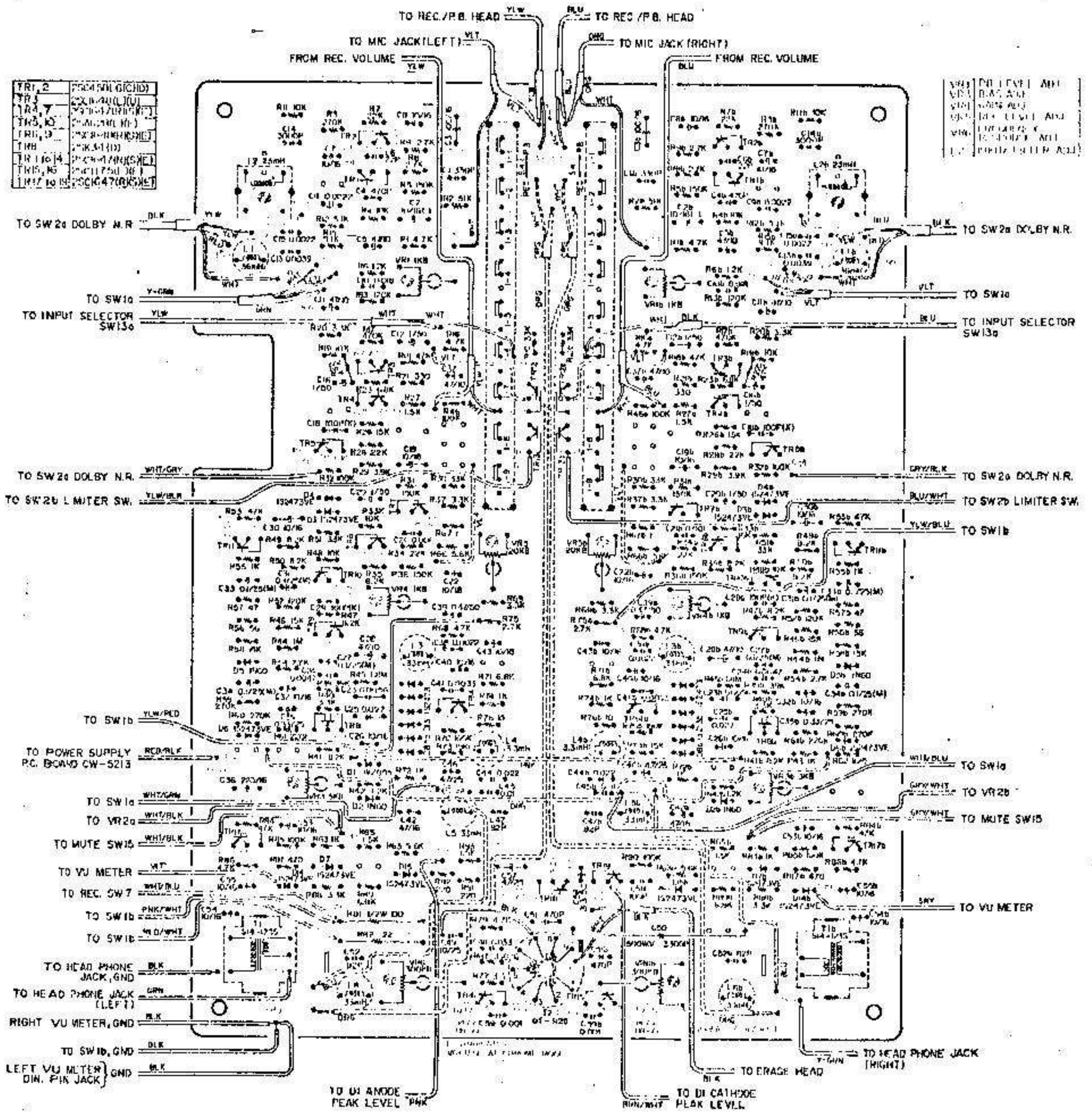

2) PEAK LAMP P.C. BOARD (CW-1061)

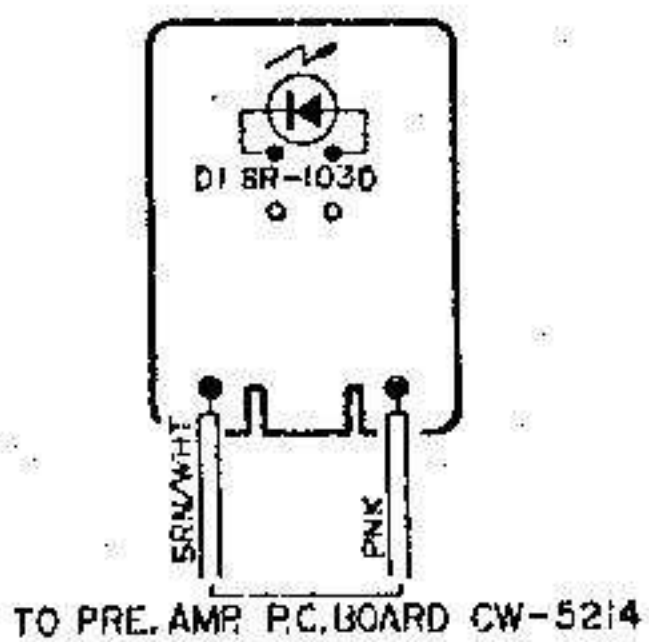

3) POWER SUPPLY P.C. BOARD (CW-5213)

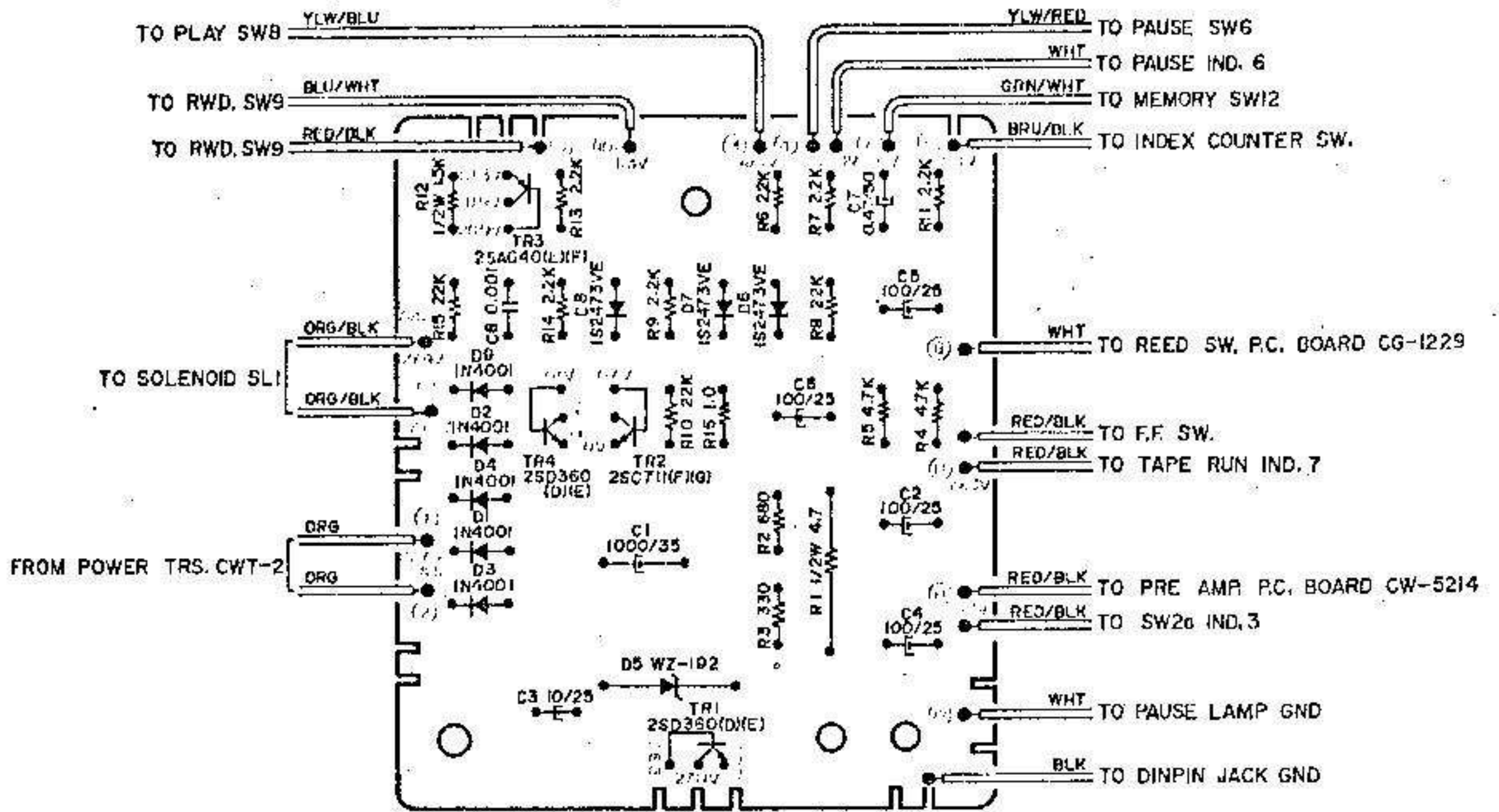

4) FUSE P.C. BOARD (CH-5311)

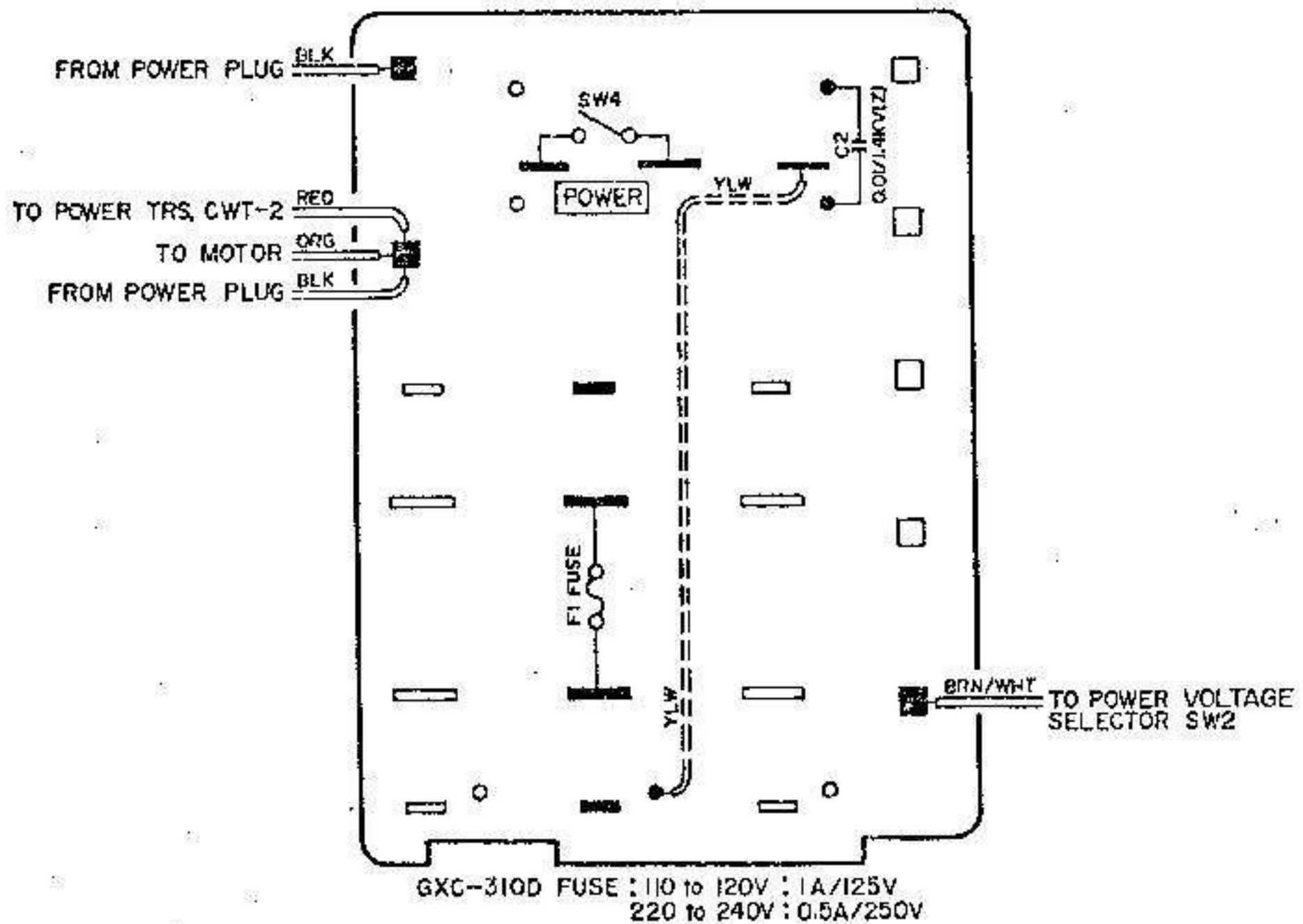

5) REED SWITCH P.C. BOARD (CG-1229)

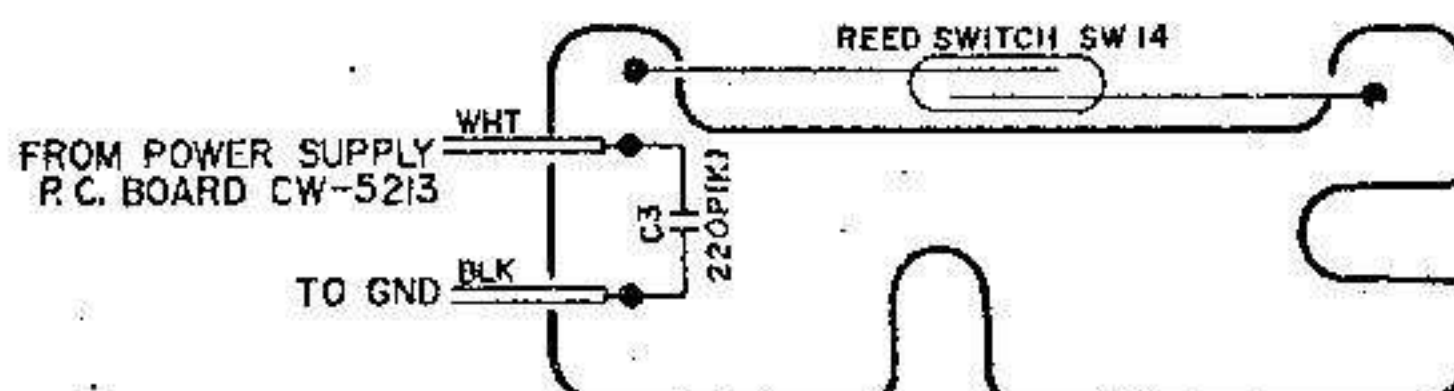

6) VU LAMP P.C. BOARD (MY-5015)

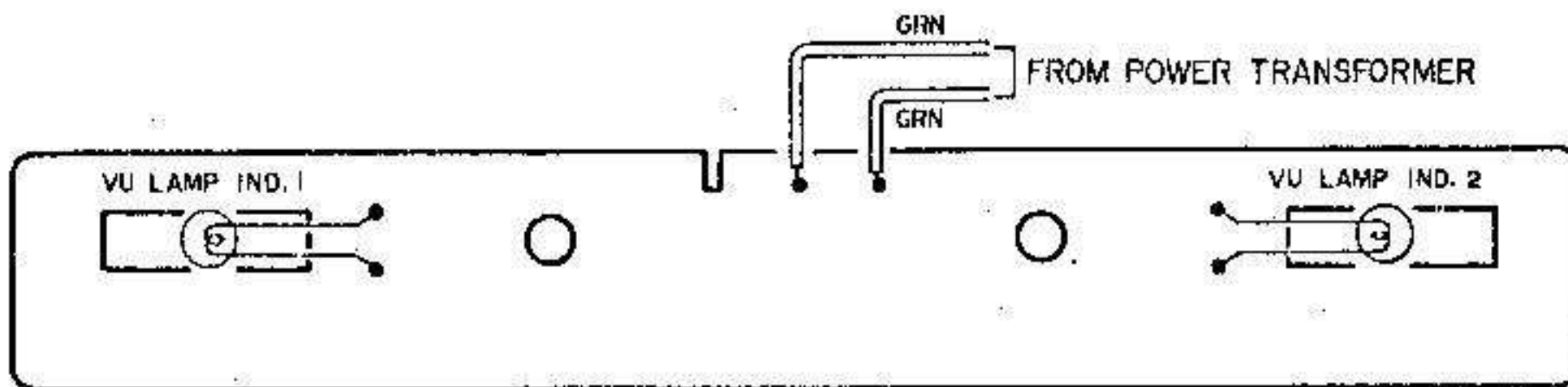

7) MAIN AMP. P.C. BOARD (CG-5810)

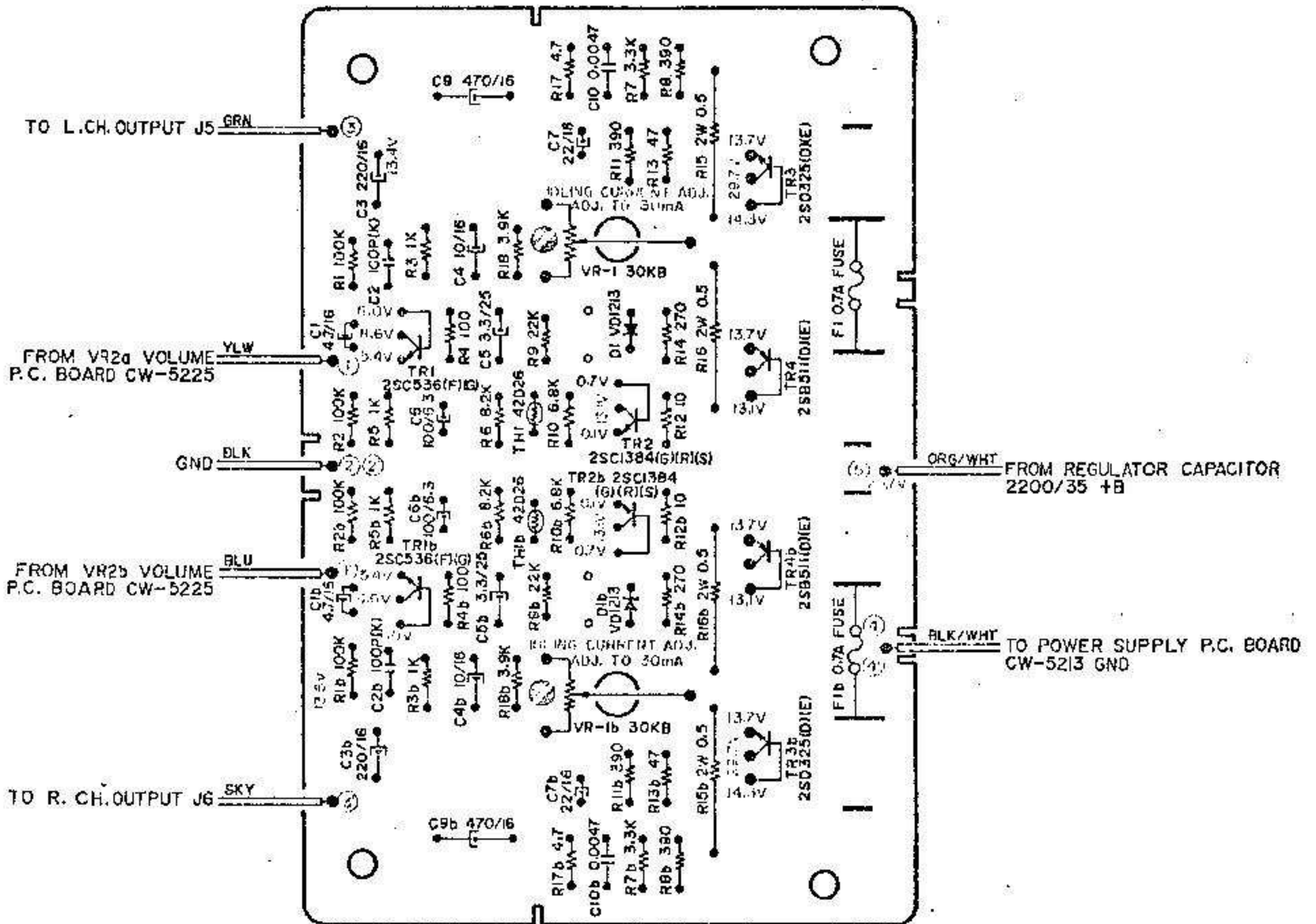

8) VOLUME CONTROL P.C. BOARD (CW-5225)

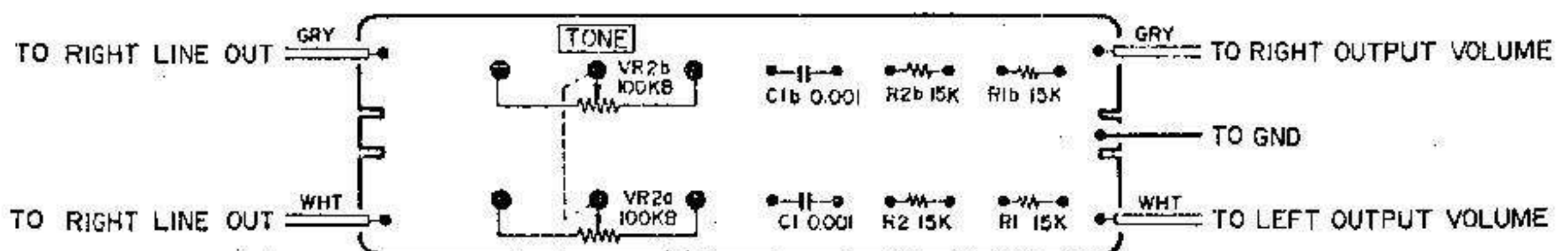

X. PEAK LEVEL INDICATOR OPERATION

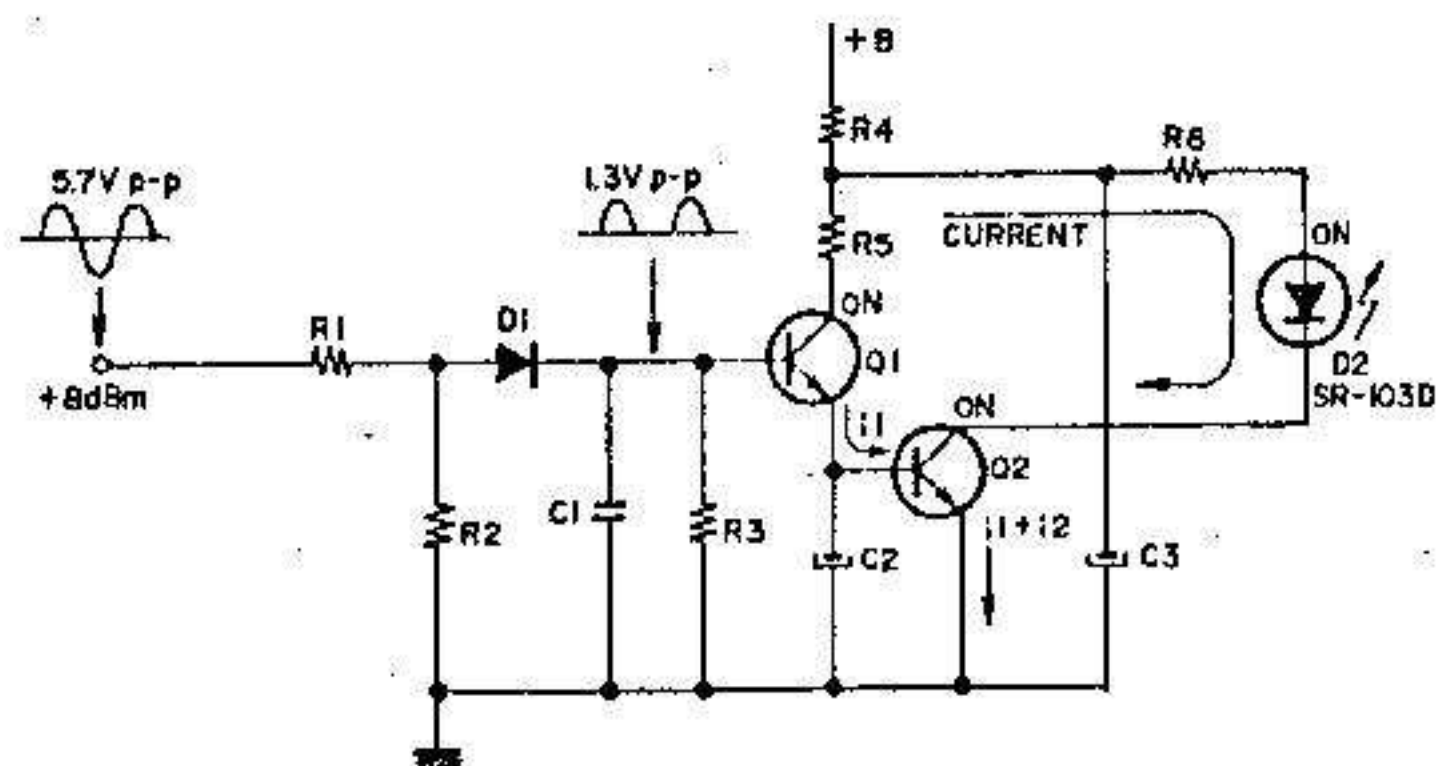

Fig. 11

The Peak Level Indicator is for the purpose of maintaining a recording signal amplitude (VU) range of within +8 dB in order not to exceed the saturation point of the tape during recording. With line level volume VR2 at maximum when there is a signal exceeding +8 dBm at the line output terminal, this peaking indicator lamp will light.

The peaking circuit is comprised of attenuator (R_1 , R_2), rectifier (D_1 , C_1 , R_3), switching (Q_1 , Q_2 , R_5 , C_2 , C_3) and luminous diode (R_6 , D_2). When the recording signal reaches 8 dBm a 1.3Vp-p D.C. half-wave rectifying current is supplied to the base of Q_1 and Q_1 lead-through is effected (Q_1 is turned ON). Then operating current i_1 flows to the base of Q_2 from Q_1 emitter and Q_2 lead-through is also effected.

In other words, the switching circuit is turned "ON", current i_2 from +B flows to $R_4 \rightarrow R_6 \rightarrow D_2 \rightarrow Q_2$ (collector \rightarrow emitter) and D_2 (SR-103D) is activated. Q_1 is turned "OFF" at +6 dBm recording input signal, and switching takes place at +7 dBm. However, because of the slight variation in luminous diode lead-through current, there is a ± 1 dBm switching point deviation.

Caution: Because the Limiter Circuit functions at +3 dBm (3 VU), when the peaking level facility is being used, set Limiter Switch to OFF position.

FIG. 1 ILLUSTRATION OF HEAD BLOCK

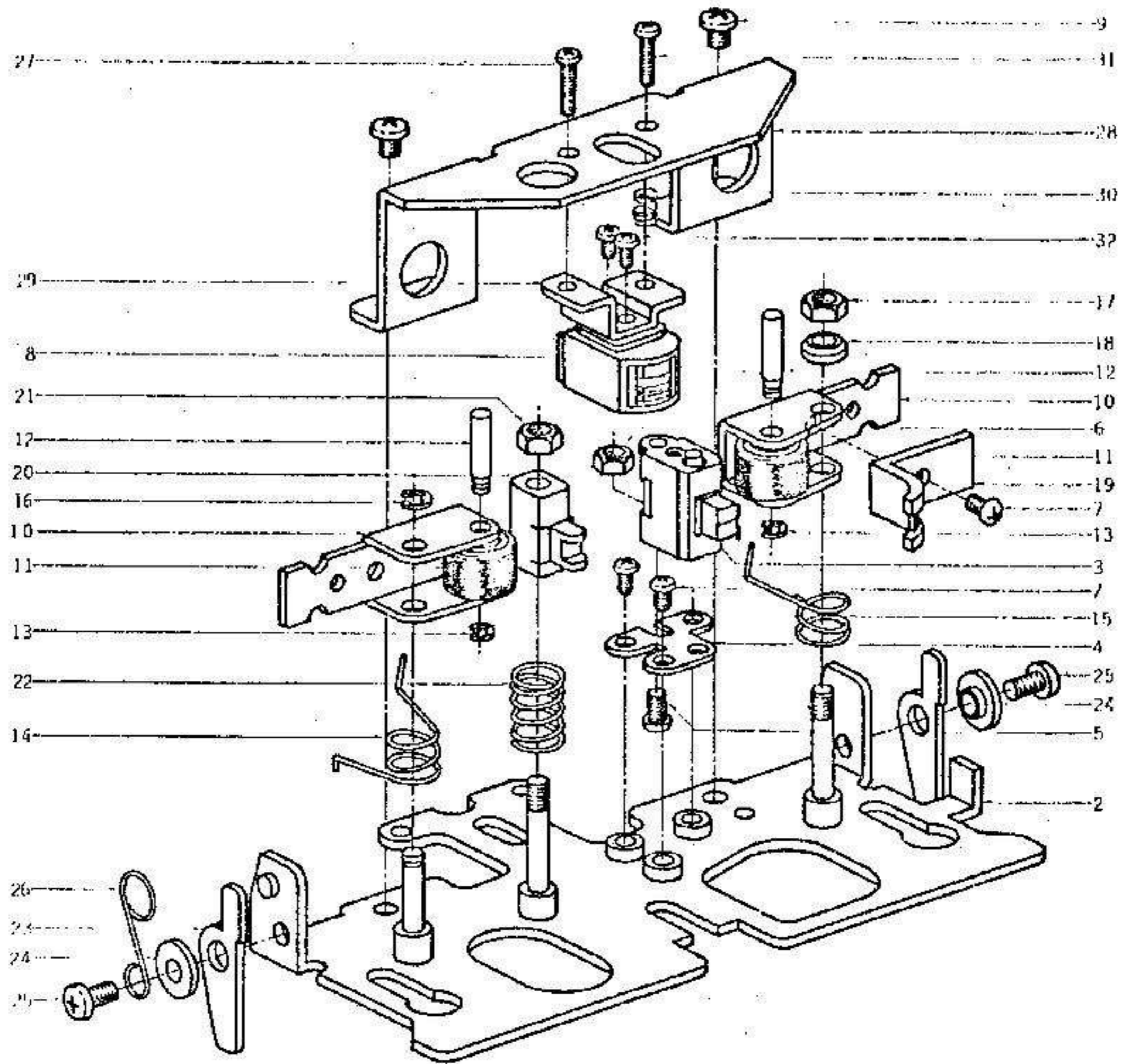

HEAD BLOCK

Ref. No.	Parts No.	Description	Schematic No.	Q'ty	Ref. No.	Parts No.	Description	Schematic No.	Q'ty
1-1x	BH623463	Head Block Comp.	CW	1	1-21	ZW516993	Nut M3		1
1-2	HZ613956	Head Base, w/shaft	CW-0001	1	1-22	ZG365297	Clutch Spring B	KCC-1382	1
1-3	HE636963	ERASE HEAD E4-165	CW	1	1-23	ML612562	Pause Lever H	CW-0004	2
1-4	HZ567202	Erase Head Plate	CP-0029	1	1-24	HZ567077	Graduate Collar	CP-0009	2
1-5	ZS417161	Screw, pan head 2.3x4		1	1-25	ZS422076	Screw, pan head 3x5		2
1-6	ZW273688	Nut M2.3		1	1-26	TC655841	Shield Retainer	CW-0043	1
1-7	ZS201407	Screw, pan head 2.3x3		5	1-27	ZS465298	Screw, pan head 2.3x10		2
1-8	HP564085	REC/P.B HEAD P4-341		1	1-28	HZ626488	Head Mt. Plate	CW-0201	1
1-9	ZS432674	Screw, pan head 3x3		2	1-29	HZ626490	PH Head Table	CW-0202	1
1-10	TC612617	Pinch Roller Arm	CW-0009	1	1-30	ZG465636	Angle Adjust Spring	CG-0029	3
1-11	MP612628	Pinch Roller D=11	CW-0010	2	1-31	ZS364397	Screw, pan head 2.3x10		1
1-12	MS389981	Pinch Roler Shaft	CS-0011	2	1-32	ZS477876	Screw, pan head 2x3		2
1-13	ZW391397	'E' Ring 1.2M	6-1-9	2					
1-14	ZG639371	Pinch Roller Spring (1)	CW-0008	1					
1-15	ZG639382	Pinch Roller Spring (2)	CW-0009	1					
1-16	ZW270088	'E' Ring 1.9M	6-1-9	1					
1-17	ZW516993	Nut M3		1					
1-18	TC614136	Collar	CW-0033	1					
1-19	HZ612595	Tape Guide 1	CW-0007	1					
1-20	HZ612606	Tape Guide 2	CW-0008	1					

FIG. 2 ILLUSTRATION OF
MOTOR BLOCK

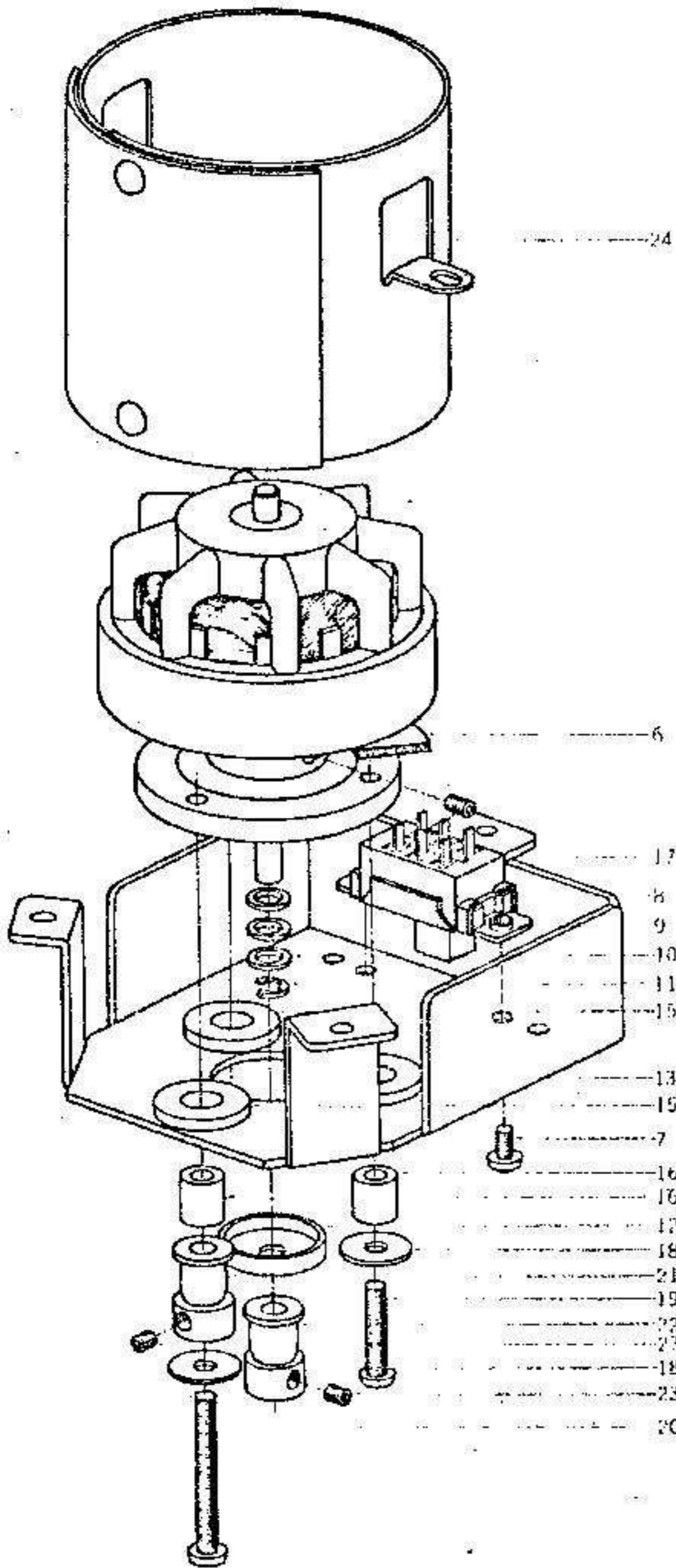

MOTOR BLOCK

Ref. No.	Parts No.	Description	Schematic No.	Q'ty
2-1x	BM623452	Motor Block (HM1-12CS) Comp.	CP, CH, CW	1
2-2x	BM648898	Motor Block (HM1-12CS) Comp. (CEE)	CP, CH, CW	1
2-3x	BM648900	Motor Block (HM1-12CS) Comp. (CSA)	CP, CH, CW	1
2-4x	BM636142	Motor Block (HM1-12CS) Comp. (310)	CP, CH, CW	1
2-5x	BM648922	Motor Block (HM1-12CS) Comp. (310) (CSA)	CP, CH, CW	1
2-6	EA391331	Motor Lead Terminal P.C. Board	CS-7025	1
2-7	ZS422076	Screw, pan head 3x5		4
2-8	ZW396415	Thrust Washer A, CS (Teflon)	CS-7029	3
2-9	ZW396426	Thrust Washer B, CS (Nylon)	CS-7029	3
2-10	ZW259738	Washer (Polyslider) D4.1x7x0.25t		2
2-11	ZW270101	'E' Ring 3M	5-1-9	1
2-12	TC394075	Oil Cut	CS-7028	1
2-13	MZ616714	Motor Bracket	CW-7201	1
2-14x	MZ632777	Motor Bracket B (310)	CW-7201	1
2-15	TC384164	Rubber Cushion Bush	24X0-717	3
2-16	TC469563	Rubber Cushion Sleeve, CG	CG-7010	3
2-17	ES479485	Slide SW. S-1	25-3-66	1
2-18	ZW402322	Washer (SUP) D4.1x13x0.5t		3
2-19	ZS593201	Screw, pan head 3x16		3
2-20	ZS608354	Screw, pan head 3x30		1
2-21	MR626725	Motor Pulley 1 (60c/s)	CW-7202	1
2-22	MR626736	Motor Pulley 2 (50c/s)	CW-7202	1
2-23	ZS434160	Set Screw, hexagon socket 3x3 (cup/p.)		2
2-24	MZ632384	Motor Shield B	CW-1048	1

FIG. 3 ILLUSTRATION OF
REEL TABLE BLOCK

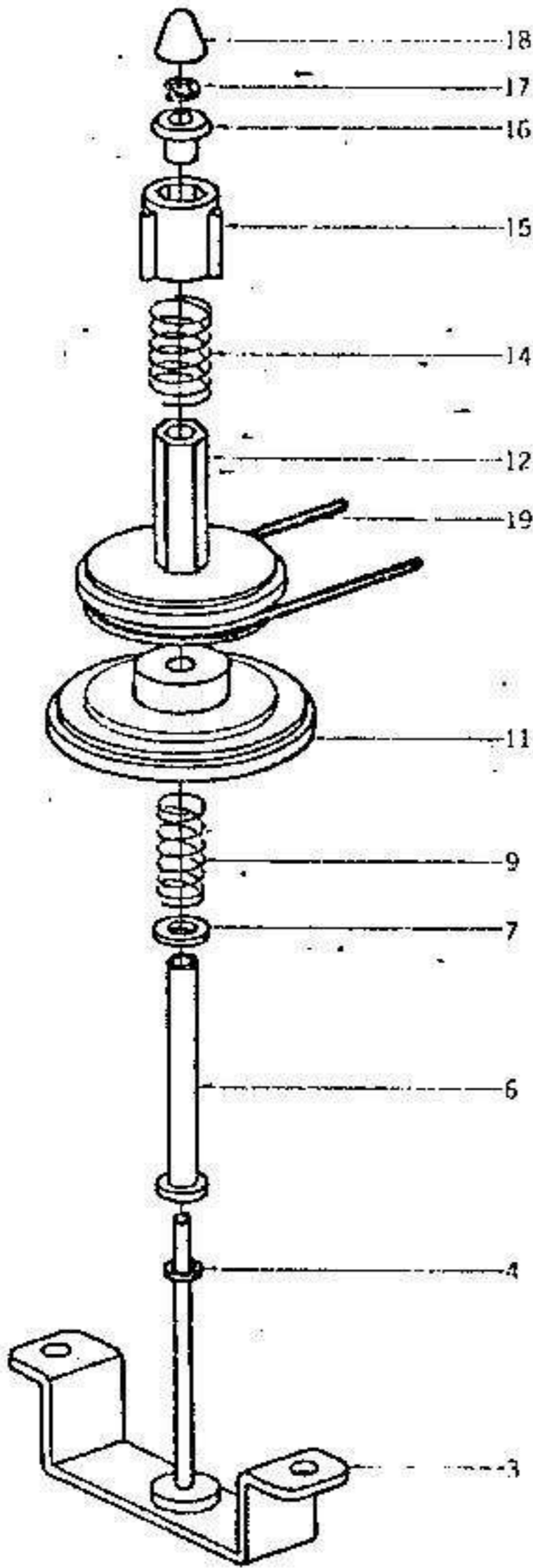

REEL TABLE BLOCK

Ref. No.	Parts No.	Description	Schematic No.	Qty
3-1x	BR620796	Supply Reel Table Block		
		Comp.	CW	1
3-2x	BR657123	Take-up Reel Table Block		
		Comp.	CW	1
3-3	MT578261	Reel Table Bracket, w/shaft	CP-1173	1
3-4	ZW364342	Washer (Polyslider)		
		D1.7x3.2x0.25t		2
3-5x	ZW649877	Washer (Luminer)		
		D3.2x8x0.12t		1
3-6	MS387573	Take-up Reel Table Shaft	CS-2007	1
3-7	ZW355307	Washer (BSP)		
		D2.6x6.9x0.5t		1
3-8x	ZW621437	Washer (Fellon)		
		D2.6x6.9x0.5t (Supply)		1
3-9	ZG387584	Clutch Spring	CS-2008	1
3-10x	ZG614812	Back Tension Spring	CW-1066	1
3-11	MR387606	Take-up Reel Table Pulley		
		Comp.	CS-2009H	1
3-12	TC387630	Take-up Reel Table Comp.	CS-2012H	1
3-13x	MZ648573	Reel Felt	CW-2017	1
3-14	ZG385075	Reel Table Spring	CS-2014	1
3-15	MT370361	C Type Reel Table Blade	RCC-1345	1
3-16	TC387641	Take-up Reel Table Bush	CS-2015	1
3-17	ZW270088	'E' Ring 1.9M	6-1-9	1
3-18	TC394200	Take-up Reel Cap	CS-2105	1
3-19	MB613258	Counter Belt D=80x1x1	CW-1045	1

FIG. 4 ILLUSTRATION OF OPERATION BUTTON/METER BASE BLOCK

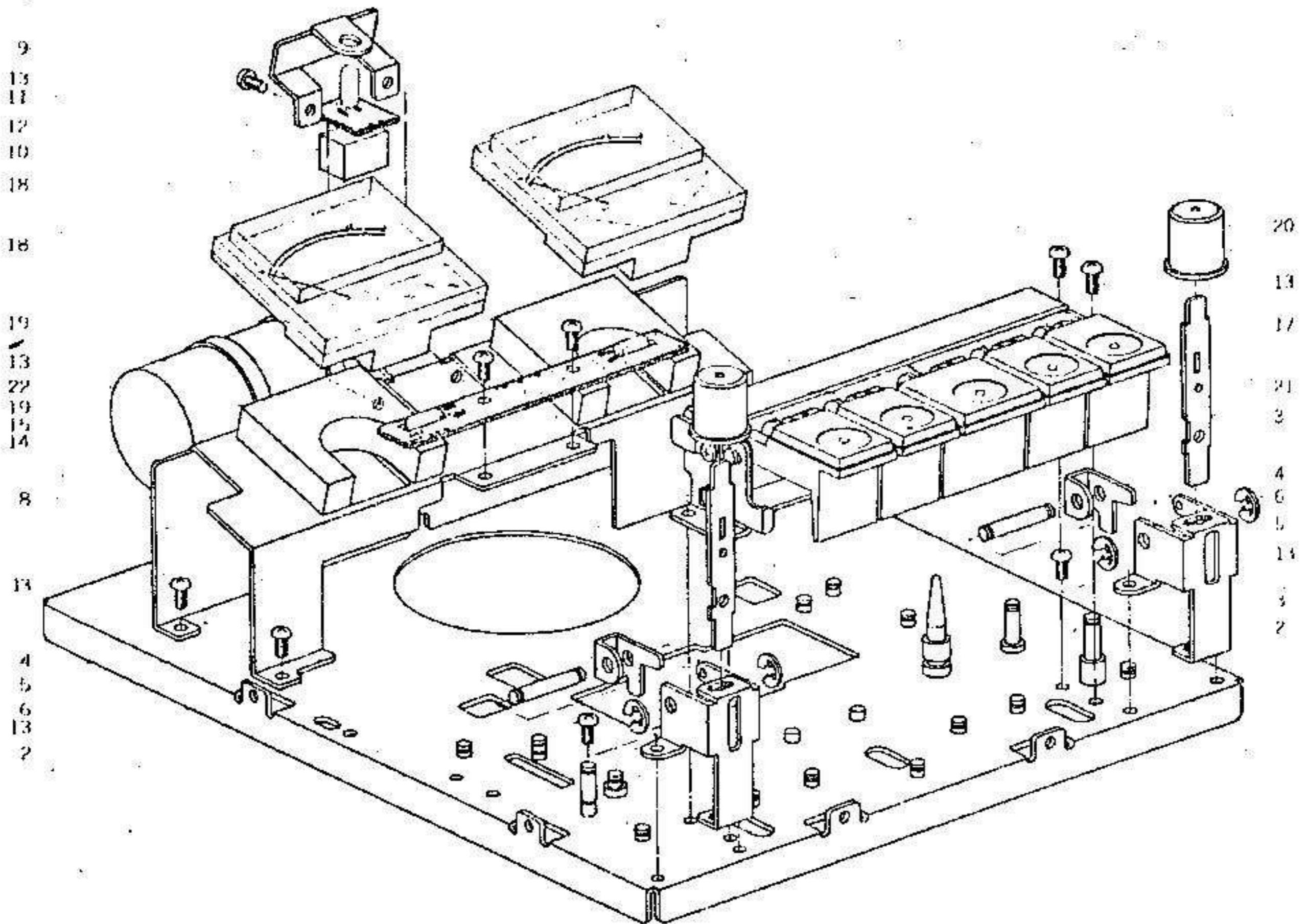

OPERATION BUTTON/METER BASE BLOCK

Ref. No.	Parts No.	Description	Schematic No.	Q'ty
OPERATION BUTTON BLOCK				
4-1x	BZ620842	Operation Button Block Comp.	CW	1
4-2	TC613473	Pause Holder	CW-2012	1
4-3	SB457413	Operation Button A	CG-2006	1
4-4	TC457424	Button Lever	CG-2005	1
4-5	MS613484	Pause Shaft	CW-2013	1
4-6	ZW290283	'U' Ring 2.85M	6-1-1	4
METER BASE BLOCK				
4-7x	BZ623485	Meter Base Block Comp.	CW	1
4-8	TC626663	Meter Table	CW-2201	1
4-9	TC626512	Penk Level Table	CW-1201	1
4-10	TC613776	Lamp Mat	CW-5026	1
4-11	ED522887	Luminous Diode SL-103	45-15-2	1
4-12	EA614158	Peak Lamp P.C. Board	CW-1061	1
4-13	ZS325495	Tapping Screw #2 3x6		14
4-14	EA627276	VU Lamp P.C. Board	MY-5015	1
4-15	EL621167	Pilot Lamp 5.5V 60MA	28-2-36	2
4-16x	EZ639990	Lamp Shield B	CW-1214	2
4-17	BK620583	Keyboard SW.	CW-3003	1
4-18	EM619705	VU Meter D18A41R	46-1-96	2
4-19	EZ449471	VU Mat	HS-5010	2
4-20	SB613495	Push Button A (Orange)	CW-2014	1
4-21	SB613506	Push Button B (Blue)	CW-2014	1
4-22	EC641338	MP/C. 7+1 μF 150WV AC (Lug Type Unt/D.)	24-9-95	1
4-23x	EC641340	MP/C. 7 μF 150WV AC (Lug Type Unt/D.) (CSA)	24-9-101	1

FIG. 5 ILLUSTRATION OF TAKE-UP LEVER/WIND LEVER BLOCK

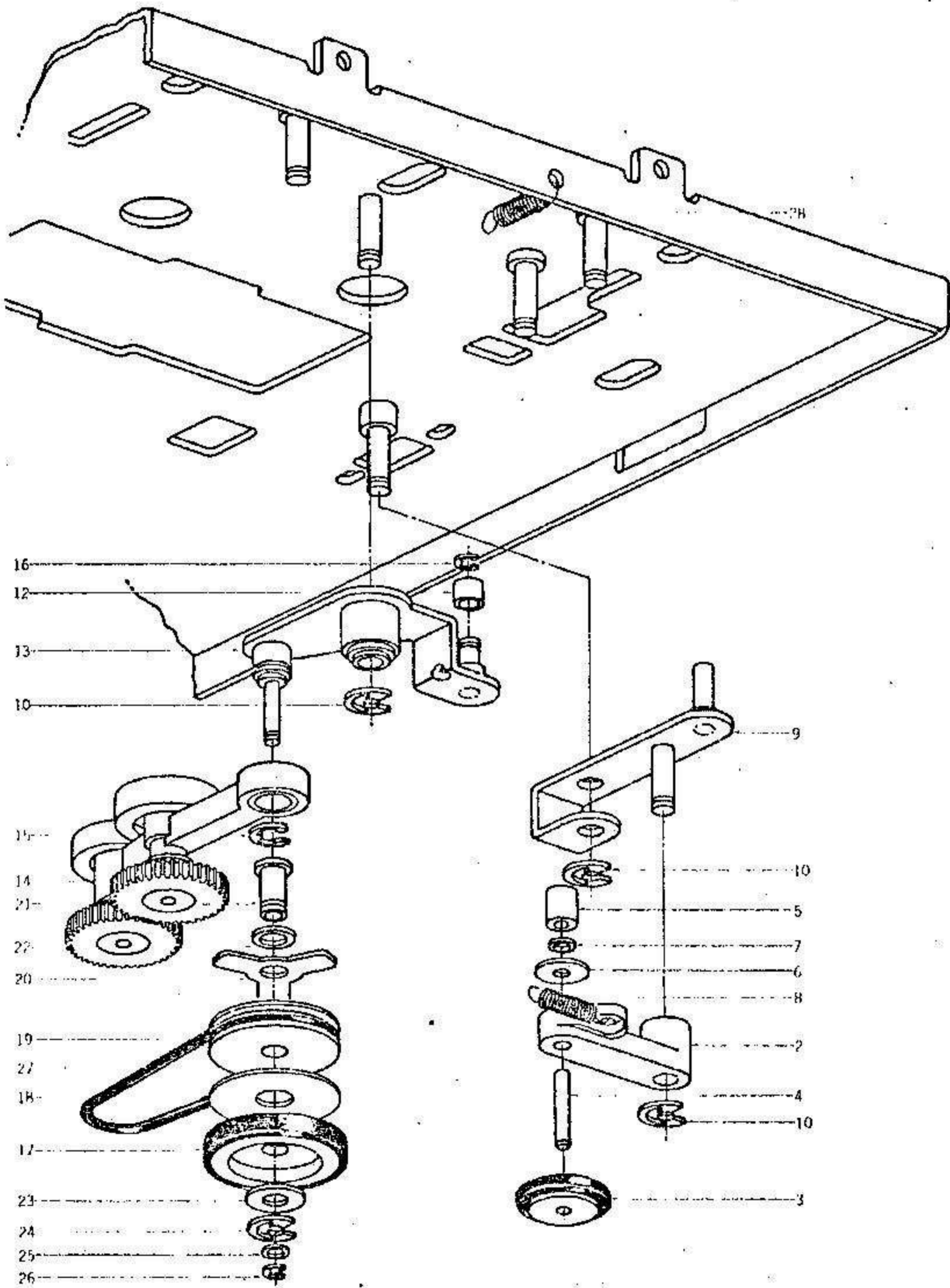

TAKE-UP LEVER/WIND LEVER BLOCK

Ref. No.	Parts No.	Description	Schematic No.	Q'ty
TAKE-UP LEVER BLOCK				
5-1x	BL620818	Take-up Lever Block Comp.	CW	1
5-2	ML613440	Take-up Lever, w/metal	CW-2000	1
5-3	MI613451	Take-up Wheel	CW-2007	1
5-4	MS613372	Take-up Wheel Shaft	CW-1062	1
5-5	MR456761	Take-up Pulley	CG-1032	1
5-6	ZW530504	Oil Cot Washer (Mylar)	CG-1102	1
5-7	ZW474581	Washer (Teflon) D2.05x3.5x0.2t		1
5-8	ZG469315	Take-up Lever Spring	CG-1091	1
5-9	ML612922	Idler Lever, w/prop	CW-1032	1
5-10	ZW290283	'U' Ring 2.85M	6-1-1	3
WIND LEVER BLOCK				
5-11x	BL620820	Wind Lever Block Comp.	CW	1
5-12	MR647122	Roller	CW-1086	1
5-13	ML612718	Wind Lever 1, w/shaft	CW-1011	1
5-14	BZ620831	Wind Gear Comp.		1
5-15	ZW270123	'E' Ring 4M	6-1-9	1
5-16	ZW270088	'E' Ring 1.9M	6-1-9	1
5-17	MI638032	Wind Wheel 1-C	CP-1126	1
5-18	MT632733	Clutch Felt	CW-1078	1
5-19	MI566561	Wind Wheel 2	CP-1127	1
5-20	ZG626264	Clutch Spring	CW-1073	1
5-21	TC461878	Wheel Collar	CG-2025	1
5-22	ZW620548	Washer (PBP) D4.1x7.1x0.3t		1
5-23	ZW620550	Washer (SUP) D4.1x11x0.3t		1
5-24	ZW290283	'U' Ring 2.85M	6-1-1	1
5-25	ZW474581	Washer (Teflon) D2.05x3.5x0.2t		1
5-26	ZW356657	'E' Ring 1.5M	6-1-9	1
5-27	MB613260	Wind Belt D33.2x1.8x1.8	CW-1046	1
5-28	ZG626275	Wind Lever Spring	CW-1071	1

MECH. FRAME BLOCK (1)

Ref. No.	Parts No.	Description	Schematic No.	Q'ty
TAPE RUN BLOCK				
6-1x	BZ592773	Tape Run Block Comp.	CH, CW	1
6-2	MZ596002	Pinion Base, w/shaft	CH-1009	1
6-3	TC541833	Pinion A	CZ-2012	1
6-4	TC541855	Pinion Shaft	CZ-2014	1
6-5	MZ595732	Flat Gear	CH-1046	1
6-6	MZ596024	Tape Run Drum	CH-1011	1
6-7	ZW595697	Washer (Teflon) D1.3x3.6x0.25t	CH-1051	1
6-8x	SE595708	Tape Run Mask	CH-1052	1
MECH. FRAME BLOCK				
6-9x	EJ331380	Lug Plate KP1L1	33-3-16	1
6-10	ZS325495	Tapping Screw #2 3x6 (BR)		11
6-11	TC613170	Play Slide, w/pin	CW-1037	1
6-12	ZW290283	'U' Ring 2.85M		33
6-13	TC613236	Brake Slide	CW-1043	1
6-14	ZG568034	Brake Shoe	CP-1022	1
6-15	ZG456930	Brake Spring	CG-1040	1
6-16	TC613214	Cassette Retaining Plate	CW-1041	1
6-17	TC613203	Eject Slide	CW-1040	1
6-18	ZG224796	New Spring D	MH-142	1
6-19	TC626545	Mute SW. Table	CW-1207	1
6-20	ES539043	Push SW. SPJ-10108	25-5-92	1
6-21	ZS460440	Screw, pan head 2x4		2
6-22	ML612843	Eject Prevention Lever	CW-1024	1
6-23	ZG580252	Rock Plate A Spring	TD-2015	1
6-24	TC612865	F.F. Slide	CW-1026	1
6-25	TC612876	RWD Slide	CW-1027	1
6-26	TC612854	REC. Slide	CW-1025	1
6-27	ZG227452	Spring D	900-118	1
6-28	TC626703	Slide Plate A	CW-1208	1
6-29	MZ626556	SW. Table	CW-1209	1
6-30	ES389700	Micro SW. SS-5	25-1-19	1
6-31	ZS487091	Screw, pan head 2.3x8		2
6-32	MZ644220	Bias Switch Plate	CW-1215	1
6-33	TC612955	REC. Detector Plate	CW-1035	1
6-34	ZG529683	REC. Pull Spring B	ND-5029	1
6-35	MZ397080	Spring Rack	KD-1010	1
6-36	TC613361	Cassette Base Plate, w/pin	CW-1059	1
6-37	TC613315	Friction Felt	CW-1052	1
6-38	TC626534	Play SW. Plate	CW-1204	1
6-39	ZG451574	Slider Pull Spring	RCC-1207B	1
6-40	TC613192	Pause Slide 3, w/shaft	CW-1039	1
6-41	ML413181	Pause Lever 3	CW-1038	1
6-42	ML612933	Cancellation Lever 2, w/pin	CW-1033	1
6-43	ML626692	Cancellation Lever	CW-1206	1
6-44x	ZW322525	Washer (PBP) D4.1x7x0.2t		1
6-45	ZG369112	Head Base Return Spring	RCC-1035	1
6-46	ZG614687	Head Base Spring	CW-1065	2
6-47	ZG494403	Return Spring	CG-1204	1
6-48	EP494425	Plunger Solenoid 0730THT1	44-1-48	1
6-49	MZ596340	Plunger Base	CH-1042	1
6-50	ZS592378	Screw, pan head 2.6x3		2
6-51	MH620572	Spring Pin SPP 2.5x12		1
6-52x	ED454583	Silicon Diode 10D05	45-2-42	1
6-53x	ZG392826	REC. Lever B Return Spring	CS-1147	1
6-54	TC515575	SW. Lock Cam B	CG-2301	1
6-55	ZG514440	Button Lock Spring B	CG-2303	1
6-56	ZW452373	Washer (SPC) D3x8x0.5t		1
6-57	ZW270088	'E' Ring 1.9M	6-1-9	1
6-58	ZG577923	REC. Spring 1	CP-1172	1
6-59	MC623665	Counter SMP-390-50	9-1-41	1
6-60	ZW417161	Screw, pan head 2.3x4		2
6-61	TC613991	Cassette Base	CW-1051	1
6-62	TC457255	REC. Safety Pin	CG-1075	1
6-63	TC612832	Cassette Table Bracket B, w/pin	CW-1023	1
6-64	ZG478708	REC. Cramp Spring	CG-1094	1
6-65	ZW620627	Washer (SPC) D4.2x11x0.8t		1
6-66	ZG614698	Cassette Base Return Spring	CW-1063	1

FIG. 6 ILLUSTRATION OF MECH. FRAME BLOCK (1)

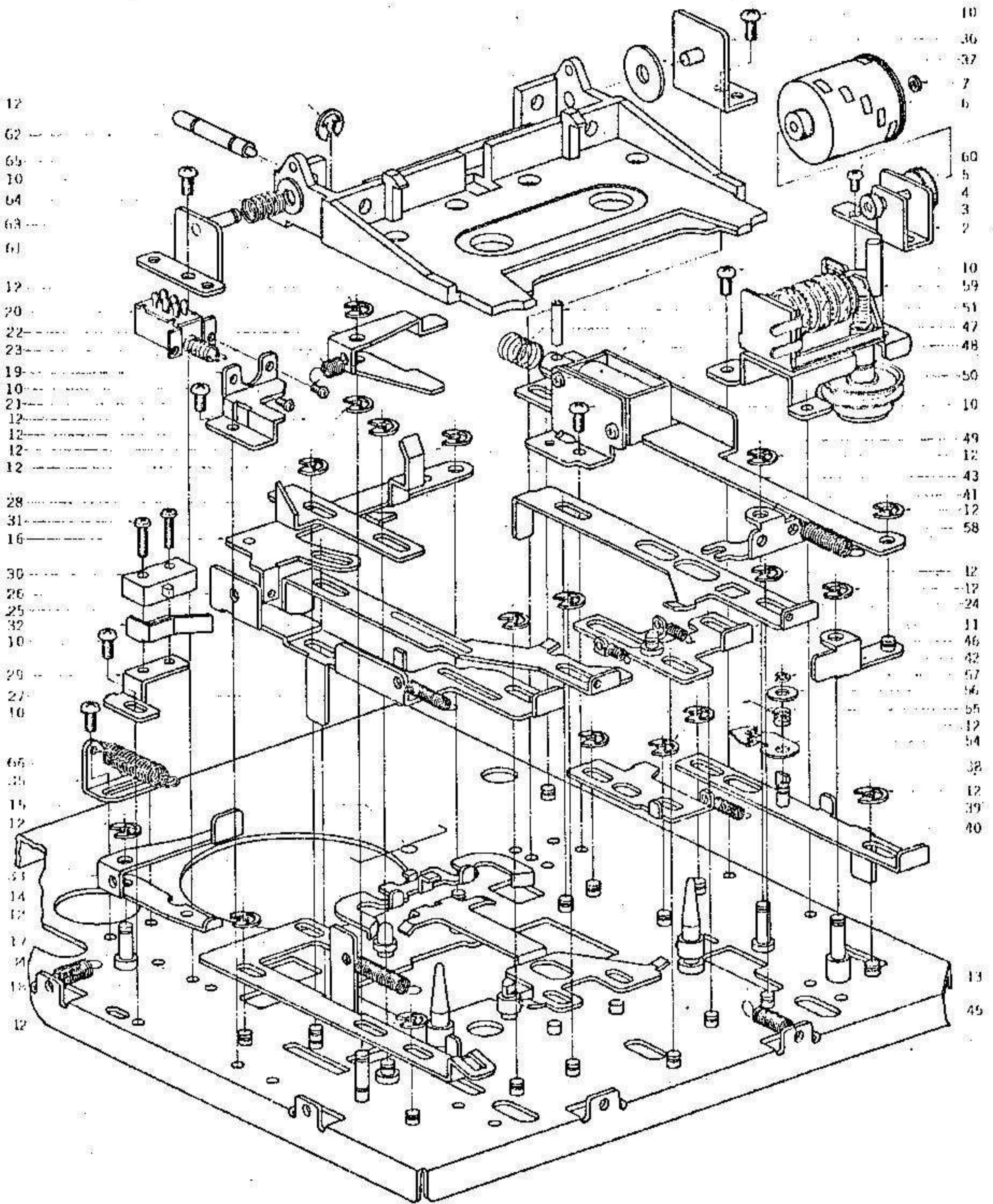
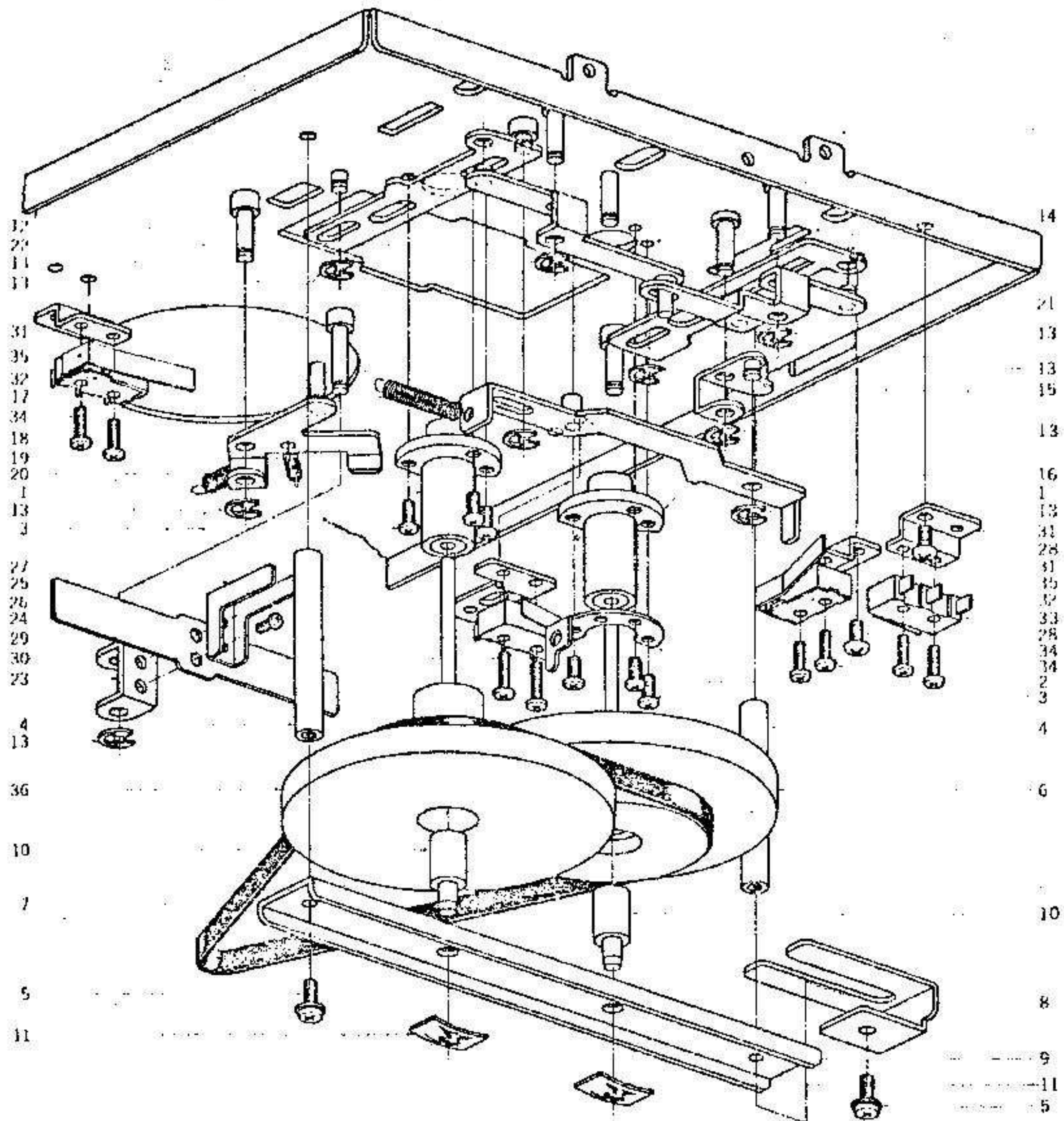

FIG. 7 ILLUSTRATION OF MECH. FRAME BLOCK (2)



MECH. FRAME BLOCK (2)

Ref. No.	Parts No.	Description	Schematic No.	Q'ty	Ref. No.	Parts No.	Description	Schematic No.	Q'ty
7-1	MV614575	Capstan Metal Case, w/metal	CW-1067	2	7-20	ZG387832	Take-up Spring	CS-20W	1
7-2	TC568214	Take-up Spring Hanger A	CP-1040	1	7-21	ML612797	Pause Lever 1, w/pin	CW-1019	1
7-3	ZS590804	Screw, pan head 2.3x6		6	7-22	ML612808	Pause Lever 2, w/pin	CW-1020	1
7-4	MH613383	Flywheel Prop	CW-1064	2	7-23	MZ595675	Wind Plate	CH-1019	1
7-5	ZS369900	Screw, pan head 3x8, w/washer		4	7-24	ZG460484	Wind Plate Spring	CG-1083	1
7-6	ML612775	Flywheel B, w/shaft	CW-1017	1	7-25	ZG612900	Wind Spring	CW-1030	1
7-7	MB613271	Capstan Belt	CW-1047	1	7-26	ZS499331	Screw, pan head 2.3x5		2
7-8	MZ638796	Belt Stopper	CW-1079	1	7-27	TC568236	REC SW. Table	CP-1041	1
7-9	TC612898	Flywheel Supporting Plate	CW-1029	1	7-28	ZS325495	Tapping Screw #2 3x6		14
7-10	TC566662	Flywheel Holder	CP-1142	2	7-29	ES477966	Micro SW. SS-5GL	25-1-23	1
7-11	ZW245981	Push Nut D4		2	7-30	ZS465298	Screw, pan head 2.3x10		2
7-12	TC612966	Pause Slide 1	CW-1036	1	7-31	MZ613247	SW. Table	CW-1044	3
7-13	ZW290283	'U' Ring 2.85M	4-11	11	7-32	ES389700	Micro SW. SS-5	25-1-19	2
7-14	TC612944	Pause Slide 2, w/pin	CW-1034	1	7-33	ES494188	Micro SW. SS-5GL-13	25-1-25	1
7-15	ML610525	REC. Prevention Lever 1-B, w/pin	CP-1125	1	7-34	ZS487091	Screw, pan head 2.3x8		6
7-16	TC612911	Wind Slide, w/pin	CW-1031	1	7-35	MZ605283	SW. Actuator	CW-1060	2
7-17	ZG365321	Idler Lever Spring	RCU-1285	1	7-36	ML612764	Flywheel A, w/capstan shaft	CW-1016	1
7-18	MT612821	Reel Brake, w/pin	CW-1022	1	7-37x	TC632406	Clip Table	CW-1212	1
7-19	ZG651251	Reel Brake Spring	CW-1007	1					

When ordering parts, please describe Parts Number, Serial Number, and Model Number in detail.

FIG. 8 PHOTO OF PRE-AMP. P.C. BOARD (CW-5214) BLOCK

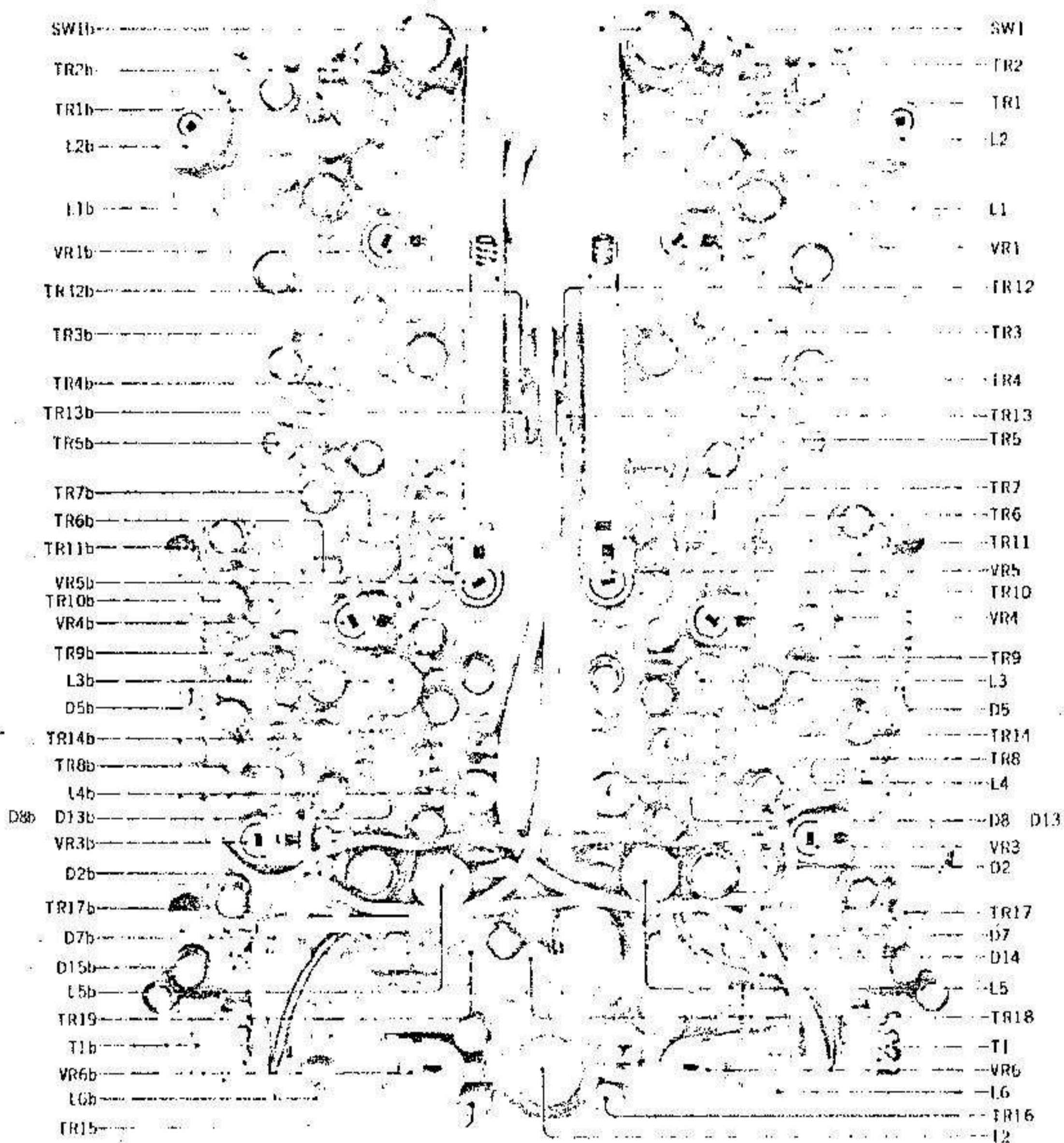

PRE-AMP. P.C. BOARD (CW-5214) BLOCK

Symbol No.	Parts No.	Description	Q'ty
8-1x	BA623632	Pre-Amp. P.C. Board Comp. (CW-5214)	1
8-TR1,2	ETJ91768	Transistor 2SC458LG(C)(D)	4
8-TR3	ET634882	Transistor 2SC1648(U)(E)	2
8-TR4	ET623733	Transistor 2SC1647(R)(S)(E)	2
8-TR5	ET557976	Transistor 2SA628(E)(F)	2
8-TR6	ET623722	Transistor 2SC1648(R)(S)(E)	2
8-TR7	ET623733	Transistor 2SC1647(R)(S)(E)	2
8-TR8	ET603270	FET Transistor 2SK34(D)	2
8-TR9	ET623722	Transistor 2SC1648(R)(S)(E)	2
8-TR10	ET557976	Transistor 2SA628(E)(F)	2
8-TR11to14	ET623733	Transistor 2SC1647(R)(S)(E)	6
8-TR15,16	ET622080	Transistor 2SC1175(E)(F)	2
8-TR17to19	ET623733	Transistor 2SC1647(R)(S)(E)	6
8-D1	ED491130	Zener Diode WZ-085	1
8-D2	ED619784	Germanium Diode 1N60	2
8-D3,4	ED560913	Silicon Diode 1S2473 VE	4
8-D5	ED619784	Germanium Diode 1N60	2
8-D6to13	ED560913	Silicon Diode 1S2473 VE	16
8-D14	ED619784	Germanium Diode 1N60	2

When ordering parts, please describe Parts Number, Serial Number, and Model Number in detail.

Symbol No.	Parts No.	Description	Q'ty
8-D15	ED560913	Silicon Diode 1S2473 VE	2
8-L1	EO496350	Inductor 146LY 36MH(J)	2
8-L2	EO624857	Inductor GE6070A 23MH(K)	2
8-L3	EO368403	Ferrit Inductor FL9H 33MH(J)	2
8-L4	EO243988	Ferrit Inductor FL7H 3.3MH(J)	2
8-L5,6	EO368403	Ferrit Inductor FL9H 33MH(J)	4
8-VR1	EV478686	Semi-fixed/Vol. V8K4-1 1 kΩ	2
8-VR3	EV464207	Semi-fixed/Vol. V8K4-1 5kΩ	2
8-VR4	EV478686	Semi-fixed/Vol. V8K4-1 1kΩ	2
8-VR5	EV522797	Semi-fixed/Vol. V8K4-1 20 kΩ	2
8-VR6	EV499882	Semi-fixed/Vol. V10K4-2 300 kΩ	2
8-T1	BT620392	Headphone Trans. S14-1235	2
8-T2	EO620482	OSC. Coil QT-925	1
8-SW1	ES494076	Slide SW. CI-109B	2
Capacitor, Vertical Type			
8-C1	EC513990	Styrol 330PF(J) 50WV	2
8-C2	EC432810	Elect. 10μF 16WV NL	2
8-C3	EC220127	Elect. 100μF 16WV	2
8-C4	EC405898	Styrol 470PF(J) 50WV	2
8-C5	EC493637	Elect. 47μF 10WV	2
8-C6	EC556525	FM 22PF(K) 500WV	2
8-C7,8	EC320051	Elect. 10μF 16WV	4
8-C9	EC250683	Mylar 0.0022μF(J) 50WV	2
8-C10	EC389485	Mylar 0.018μF(J) 50WV	2
8-C11	EC493637	Elect. 47μF 10WV	2
8-C12	EC313108	Elect. 1μF 50WV	2
8-C13	EC379787	Mylar 0.0039μF(J) 50WV	2
8-C14	EC495865	Styrol 300PF(J) 50WV	2
8-C15	EC250683	Mylar 0.0022μF(J) 50WV	2
8-C16	EC313108	Elect. 1μF 50WV	2
8-C18	EC290531	VFM 100PF(K) 50WV	2
8-C19	EC320051	Elect. 10μF 16WV	2
8-C20	EC313108	Elect. 1μF 50WV	2
8-C21	EC250604	Mylar 0.001μF(K) 50WV	2
8-C22	EC320051	Elect. 10μF 16WV	2
8-C23	EC329883	Mylar 0.0056μF(J) 50WV	2
8-C24	EC337500	Mylar 0.0047μF(J) 50WV	2
8-C25	EC329801	Mylar 0.027μF(J) 50WV	2
8-C26	EC320051	Elect. 10μF 16WV	2
8-C27	EC523282	Solid Aluminum 0.1μF(M) 25WV	2
8-C28	EC493637	Elect. 47μF 10WV	2
8-C29	EC290531	VFM 100PF(K) 50WV	2
8-C30	EC320051	Elect. 10μF 16WV	2
8-C31	EC523282	Solid Aluminum 0.1μF(M) 25WV	2
8-C32	EC320051	Elect. 10μF 16WV	2
8-C33,34	EC523282	Solid Aluminum 0.1μF(M) 25WV	4
8-C35	EC604102	Solid Aluminum 0.33μF(K) 25WV	2
8-C36	EC321208	Elect. 220μF 16WV	1
8-C37	EC493637	Elect. 47μF 10WV	2
8-C38	EC337500	Mylar 0.0047μF(J) 50WV	2
8-C39	EC487157	NP 0.47μF(M) 50WV	2
8-C40	EC320051	Elect. 10μF 16WV	2
8-C41	EC391004	Mylar 0.0033μF(J) 50WV	2
8-C42	EC320040	Elect. 47μF 16WV	2
8-C43	EC320051	Elect. 10μF 16WV	2
8-C44	EC368335	Mylar 0.022μF(J) 50WV	2
8-C45	EC250841	Mylar 0.01μF(J) 50WV	2
8-C46	EC450527	Elect. 4.7μF 25WV	2
8-C47	EC392332	VFM 82PF(J) 50WV	2
8-C48	EC423595	Mylar 0.033μF(M) 50WV	1
8-C49	EC220994	Elect. 10μF 25WV	1
8-C50	EC520468	Styrol 3300PF(J) 500WV	1
8-C51	EC405898	Styrol 470PF(J) 50WV	2
8-C52	EC392332	VFM 82PF(J) 50WV	2
8-C53to55	EC320051	Elect. 10μF 16WV	6
8-C56	EC539943	Elect. 3.3μF 50WV	1
8-C57	EC220678	Elect. 47μF 25WV	1
8-C58	EC250604	Mylar 0.001μF(K) 50WV	1
8-C59	EC250604	Mylar 0.001μF(K) 50WV	1

Carbon Resistor Omitted

FIG. 9 PHOTO OF POWER SUPPLY P.C. BOARD (CW-5213) BLOCK

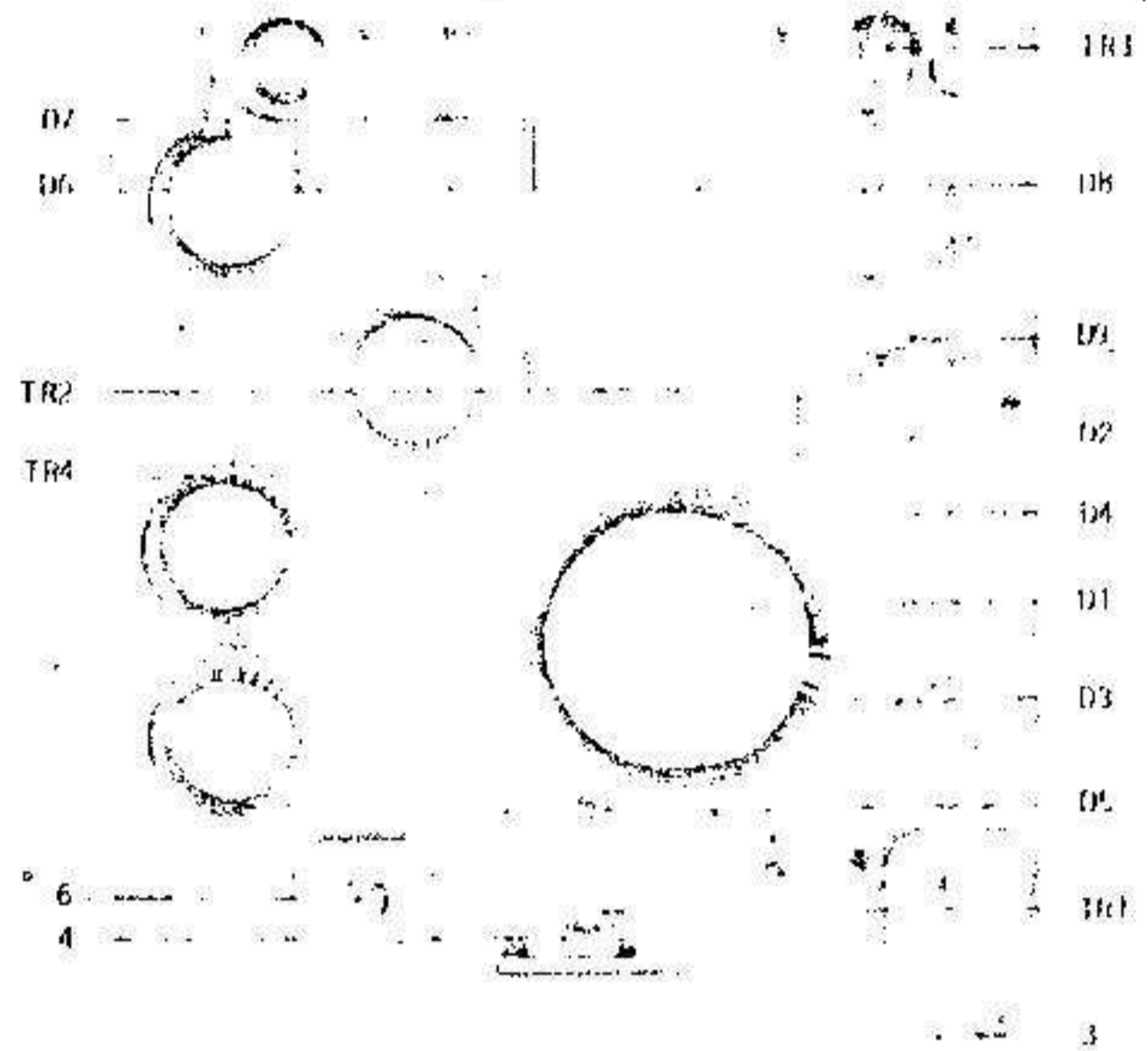

POWER SUPPLY P.C. BOARD (CW-5213) BLOCK

Symbol No.	Parts No.	Description	Q'ty
9-1x	BA623474	Power Supply P.C. Board Comp. (CW-5213)	1
9-2x	BA637244	Power Supply P.C. Board Comp. (CW-5213) (310)	1
9-TR1	ET517375	Transistor 2SD360(D)(E)	1
9-TR2	ET398777	Transistor 2SC711(G)(F)	1
9-TR3	ET623790	Transistor 2SA640(E)(F)	1
9-TR4	ET517375	Transistor 2SD360(D)(E)	1
9-D1to4	ED511097	Silicon Diode 1N4001	4
9-D5	ED498150	Zener Diode WZ-192	1
9-D6to8	ED560913	Silicon Diode 1S2473 VE	3
9-D9	ED511097	Silicon Diode 1N4001	1
9-3	EZ627625	Heat-sink Plate B	1
9-4	ZS421806	Screw, pan head 3x8	1
9-5x	ZW273756	Nut M3	1
9-6	ZW558101	Screw, pan head 3x6 w/washer	2
Capacitor, Vertical Type			
9-C1	EC432652	Elect. 1000μF 35WV	1
9-C2	EC220151	Elect. 100μF 25WV	1
9-C3	EC220994	Elect. 10μF 25WV	1
9-C4to6	EC220151	Elect. 100μF 25WV	3
9-C7	EC487157	NP 0.47μF(M) 50WV	1
9-C8	EC383501	Mylar 0.001μF(M) 50WV	1
Carbon Resistor Omitted			

FIG. 10 PHOTO OF MAIN AMP. P.C. BOARD (CG-5810) BLOCK

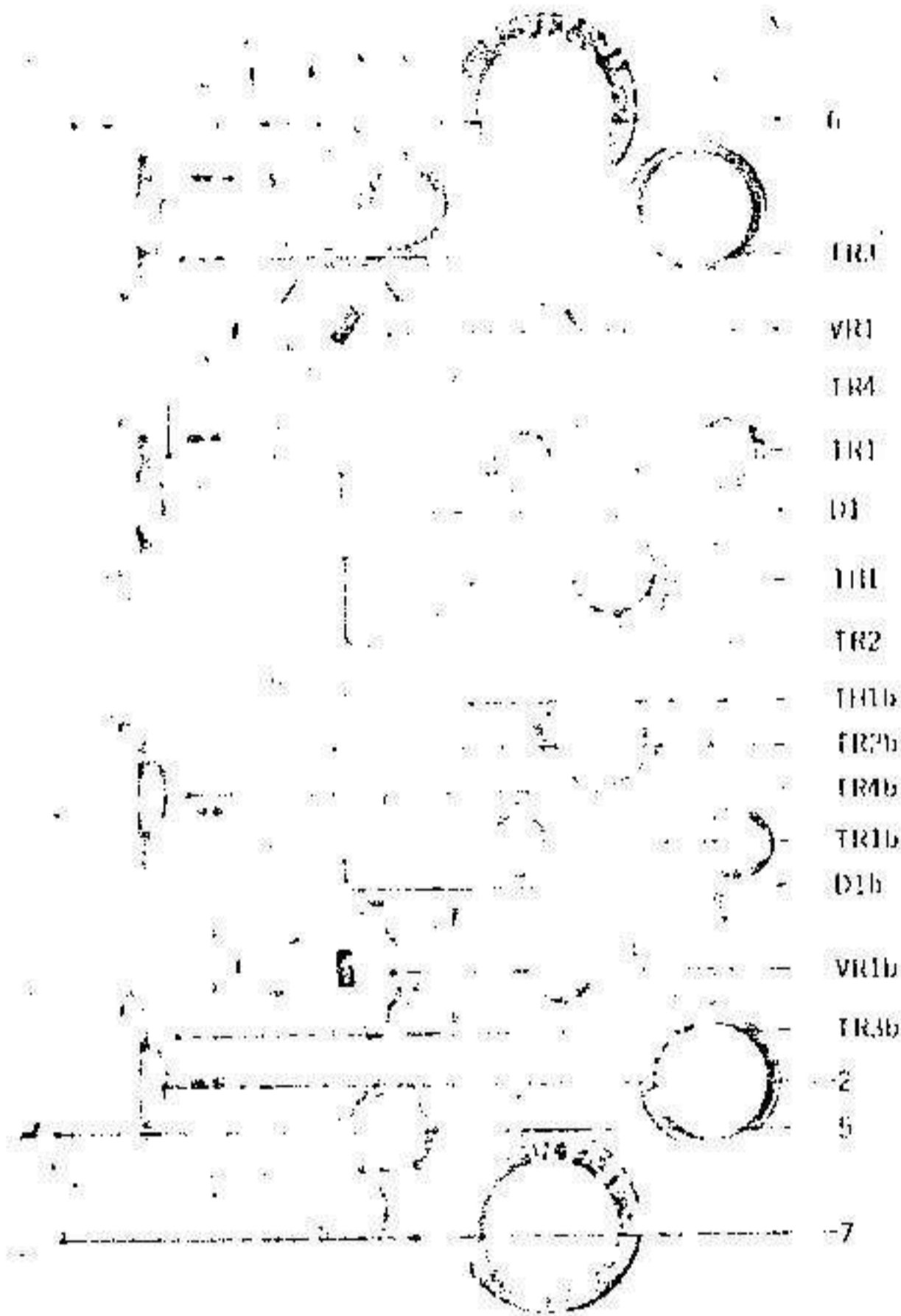

MAIN AMP. P.C. BOARD (CG-5810) BLOCK

Symbol No.	Parts No.	Description	Q'ty
10-1x	BA636197	Main Amp. P.C. Board Comp. (CG-5810)(310)	1
10-TR1	ET635231	Transistor 2SC536(F)(G)	2
10-TR2	ET623801	Transistor 2SC1384(Q)(R)(S)	2
10-TR3	ET631855	Transistor 2SD325(D)(E)	2
10-TR4	ET631866	Transistor 2SB511(D)(E)	2
10-D1	ED635242	Varistor VD1213	2
10-TH1	ED453655	Thermister 42D26	11
10-VR1	EV593368	Semi-fixed/Vol. V10K8-4-2 30 k Ω	2
10-2	ZS421806	Screw, pan head 3x8	4
10-3x	ZW273756	Nut M3	4
10-4x	EJ514822	Fuse Holder, P.C. Board S-NS051	4
10-5	EF375265	Fuse 0.7A 0.9 Ω	2
10-6	EZ632790	Heat-sink Plate C	1
10-7	ZS325495	Tapping Screw #2 3x6	2
Capacitor, Vertical Type			
10-C1	EC350706	Elect. 4.7 μ F 16WV	2
10-C2	EC290531	VFM 100PF(K) 50WV	2
10-C3	EC321208	Elect. 220 μ F 16WV	2
10-C4	EC320051	Elect. 10 μ F 16WV	2
10-C5	EC331828	Elect. 3.3 μ F 25WV	2
10-C6	EC220364	Elect. 100 μ F 6.3WV	2
10-C7	EC331705	Elect. 22 μ F 16WV	2
10-C8	EC250604	Mylar 0.001 μ F(K) 50WV	2
10-C9	EC339096	Elect. 370 μ F 16WV	2
10-C10	EC308711	Mylar 0.047 μ F(K) 50WV	2

When ordering parts, please describe Parts Number, Serial Number, and Model Number in detail.

FIG. 11 ILLUSTRATION OF REAR CHASSIS BLOCK

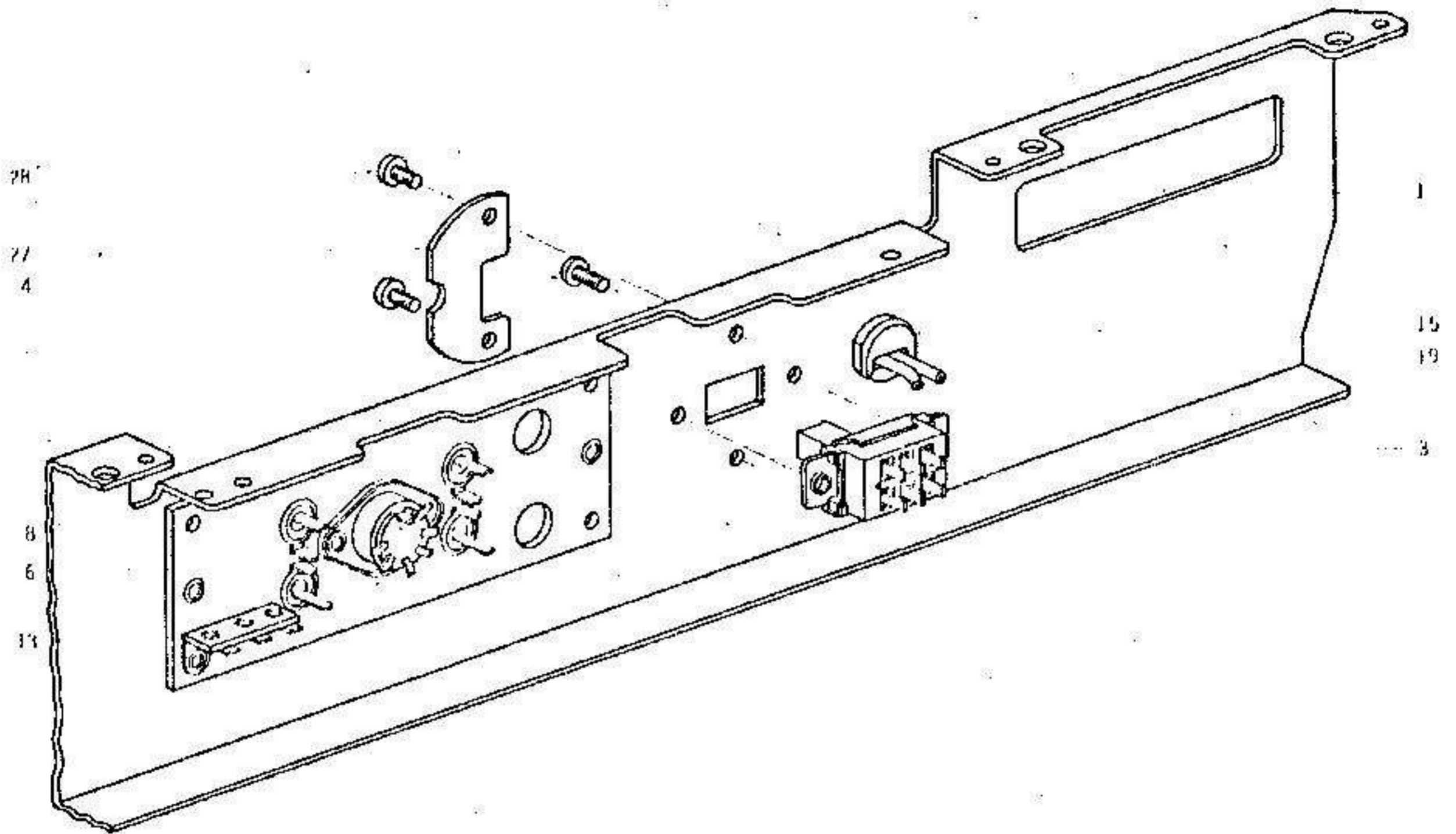

REAR CHASSIS BLOCK

Ref. No.	Parts No.	Description	Schematic No.	Q'ty
11-1	TC614182	Rear Chassis	CW-5016	1
11-2x	ER315213	Carbon/R. RD1/4 8.2k(J) (Insu. Type)	35-9-5	2
11-3	ES479485	Slide SW. S-1	25-3-66	1
11-4	ZS593177	Screw, truss head 3x8		2
11-5x	ER345712	Carbon/R. RD1/4 22k(J) (Insu. Type)	35-9-5	2
11-6	EJ620357	Jack Plate J-4	31-5-119	1
11-7x	EJ619672	Jack Plate 1-2 (310)	31-5-120	1
11-8	EJ558246	5P Din Jack	31-1-99	1
11-9x	ER440921	Carbon/R. RD1/4 27k(J) (Insu. Type)	35-9-5	1
11-10x	ER529975	Carbon/R. RD1/4 430k(J) (Insu. Type)	35-9-5	1
11-11x	ER440921	Carbon/R. RD1/4 27k(J) (Insu. Type)	35-9-5	1
11-12x	ER529975	Carbon/R. RD1/4 430k(J) (Insu. Type)	35-9-5	1
11-13	EJ255093	Lug Plate VB1L1	33-4-1	1
11-14x	SM627851	Jack Name Plate C-2	CW-5017	1
11-15	EZ382263	Strain Relief SR-4K-4	2-7-12	1
11-16x	EZ246936	Strain Relief SR-6W-1 (WG, 3 core)	2-7-8	1
11-17x	EW374894	U/L AC Cord 3M	26-3-19	1
11-18x	EW315448	Australia Cord (3 core)	26-3-11	1
11-19	EW524845	AC Cord 2.5M (J)	26-3-31	1
11-20x	EW516000	Power Cord VM-0065 (CEF)	26-3-28	1
11-21x	SM614046	Jack Name Plate A	CW-5017	1
11-22x	SM628582	Jack Name Plate F (CEF)	CW-5017	1
11-23x	SM628593	Jack Name Plate G (CSA)	CW-5017	1
11-24x	SM628604	Jack Name Plate H (JPN)	CW-5017	1
11-25x	SM632856	Jack Name Plate A-1 (310)	CW-5017	1
11-26x	SM632845	Jack Name Plate B-1 (310-CSA)	CW-5017	1
11-27	TC613697	Volt Indication Plate	CW-5018	1
11-28	ZS447764	Tapping Screw #2 3x6 (BR) (Black)		2

FIG. 12 ILLUSTRATION OF AMP. ASSEMBLY BLOCK

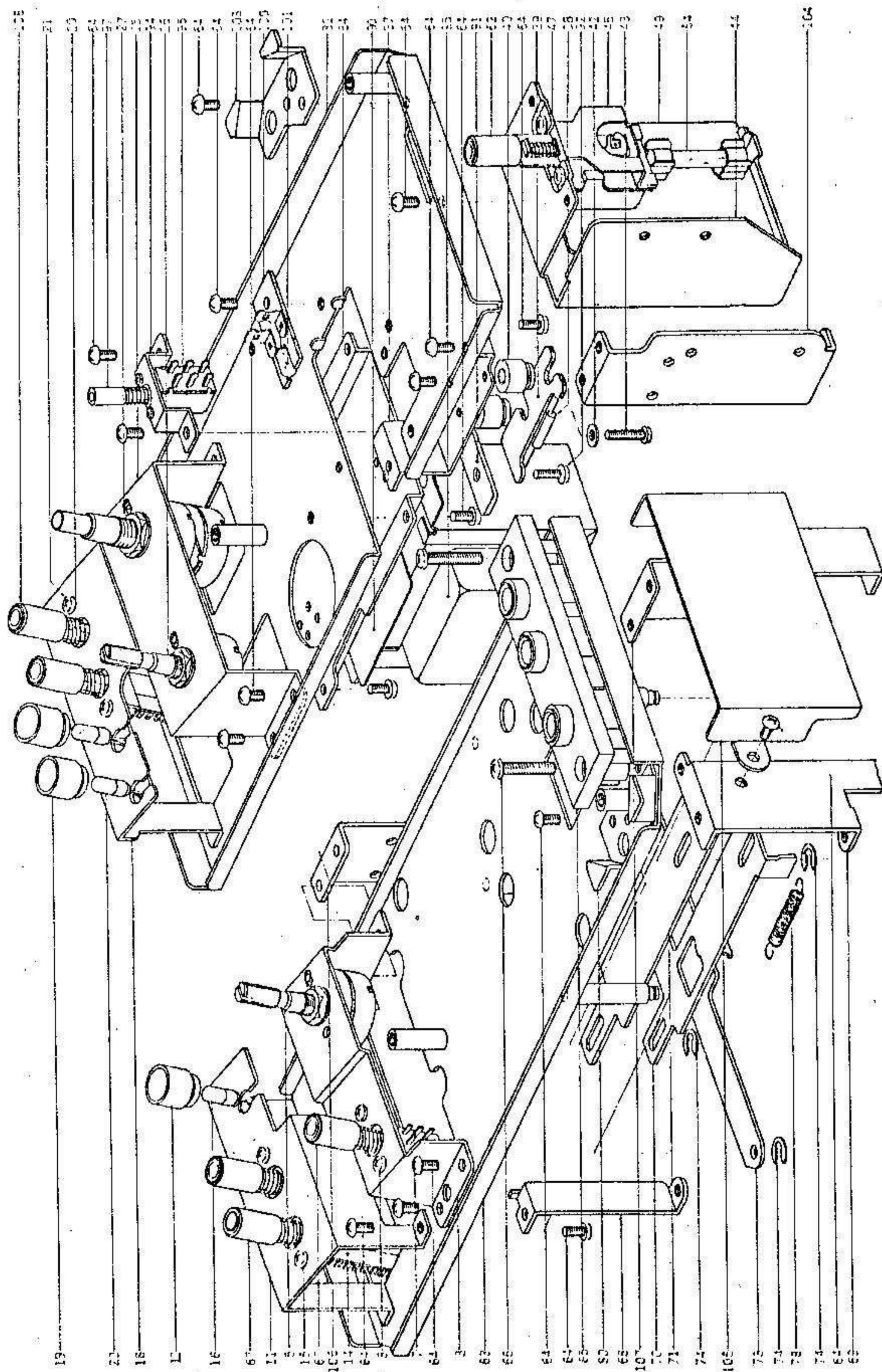

AMP. ASSEMBLY BLOCK

Ref. No.	Parts No.	Description	Schematic No.	Q'ty
VOL. PLATE (L) BLOCK				
12-1x	BZ623575	Vol. Plate (L) Block Comp. (310D)	CW	1
12-2x	BZ636210	Vol. Plate (L) Block Comp. (310)	CW	1
12-3	TC627456	Vol. Plate L-1	CW 5215	1
12-4x	TC627748	Vol. Plate L-2 (310)	CW-5215	1
12-5	EV476223	Vol. V24N 50 kA	36-2-26	1
12-6x	EV480565	Double/Vol. DJ10A 50 kAx2 (310)	36-3-41	1
12-7	ES551171	Push SW. IFS-2U-12	25-5-86	1
12-8	ZS422076	Screw, pan head 3x5		2
12-9x	ZW551182	Washer (ALP) D11.3x16x0.5t		2
SW. TABLE (L) BLOCK				
12-10x	BS623586	SW. Table (L) Block Comp.	CW	1
12-11	TC626747	SW. Table (L)	CW-5203	1
12-12	EZ586326	Lamp Holder	LF-5324	1
12-13x	EA627985	Tape Selector P.C. Board	CW 5025	1
12-14	ES620346	Push SW. CWS-1	25-5-149	1
12-15	ZS422076	Screw, pan head 3x5		2
12-16	EL623788	Lamp 24V 35MA (100M/Mx2) (Cord Type)	28-2-24	1
SW. TABLE (R) BLOCK				
12-17x	BS623542	SW. Table (R) Block (Comp)	CW	1
12-18	TC626760	SW. Table R	CW-5211	1
12-19	EZ586326	Lamp Holder	LF-5324	3
12-20	ES620537	Push SW. CWS-2	25-5-155	1
12-21	ZS422076	Screw, pan head 3x5		2
12-22	EL623812	Lamp 24V 35MA (170M/Mx2) (Cord Type)	28-2-24	2
12-23x	ER419040	Carbon/R. RD1/4 1M(J) (Stop. Type)	35-10-1	2
VOL. PLATE (R) BLOCK				
12-24x	BZ623531	Vol. Plate (R) Block Comp. (310D)	CW	1
12-25	TC626782	Vol. Plate R-1 (210D)	CW-5216	1
12-26	EV476223	Vol. V24N 50 kA (310D)	36-2-26	1
12-27	EV398575	Double/Vol. DJ20A 50 kAx2 (FR.) (310D)	36-3-25	1
12-28x	BZ636186	Vol. Plate (R) Block Comp. (310)	CW	1
12-29x	TC627750	Volume Plate R-2 (310)	CW-5216	1
12-30x	EA632788	Vol. P.C. Board (310)	CW-5225	1
12-31x	ER306887	Carbon/R. RD1/4 15k(J) (Stop. Type) (310)	35-10-1	4
12-32x	EC250885	Mylar/C. 0.01µF(K) 50WV (Vert. Type) (310)	24-1-1	2
12-33x	EV638662	Co-axial 2-throw Vol. GJ70R 100kAx2 (310)	36-1-39	1
12-34x	EV480565	Double/Vol. DJ10A 50 kAx2 (310)	36-3-41	1
12-35x	ZW551182	Washer (ALP) D11.3x16x0.5t (310)		2
REED SW. TABLE BLOCK				
12-36x	BS623553	Reed SW. Table Block Comp.	CW	1
12-37	TC626657	Reed SW. Table	CW 5212	1
12-38	ES516036	Reed SW. ORD-225	25-11-1	1
12-39	EAS16047	Reed SW. P.C. Board	CG-1229	1
12-40	TC515518	SW. Table Cushion	CG-1228	2
12-41x	EC290564	VFM/C. 220PF(K) 50WV	24-6-2	1
12-42	ZW623687	Washer (SPC) D2.4x5.8x0.4t		2
12-43	ZS462881	Screw, binding head 2.3x12		2
SW. BOX BLOCK				
12-44	EZ614902	Power Supply SW. Table	CW 5028	1
12-45	ES469541	Push SW. TV-3 JB52	25-5-60	1
12-46x	ES621178	Push SW. S-J4162 (CEE)	25-5-115	1

Ref. No.	Parts No.	Description	Schematic No.	Q'ty
12-47	ZS422076	Screw, pan head 3x5		2
12-48x	EC551160	Ceramic/C. NR821YZ 0.01µF(Z) 1.4 kVW	24-5-55	1
12-49	EA612178	Fuse P.C. Board A	CH-5311	1
12-50x	EA614788	Fuse P.C. Board B, w/fuse clip (CEE)	CH-5318	1
12-51x	EJ618805	Lug (w/calking)	32-1-56	6
12-52x	EJ514822	Fuse Holder, P.C. Board S.N5051	40-1-28	2
12-53x	EF593706	Fuse (Semko-T Type) 500 MAT (CEE)	39-1-53	3
12-54	EF563703	Fuse 2A 250V (JPN)	39-1-50	1
12-55x	EF624543	Fuse ULMF61M 250V 2A (CSA)	39-1-45	1
12-56x	EF575932	Fuse 0.8A 250V (JPN)	39-1-50	1
12-57x	EF277424	Fuse ST-4 0.8A (CSA)	39-1-28	2
12-58x	EF634487	Fuse ULMF61M 250V 1.6A (CSA)	39-1-45	1
12-59x	EF563681	Fuse 1A 250V	39-1-50	1
12-60x	EF563670	Fuse 0.5A 250V	39-1-50	1
12-61x	ZW259986	Washer (Nylon) D5.1x10.3x1t		1
12-62	SK631304	Push Button Knob 1	91-5051	6
12-63	TC627840	Amp. Chassis L-2, w/props	CW-5008	1
12-64	ZS325495	Tapping Screw #2 3x6		38
12-65	EJ555794	Jack, 3-throw S-G0911	31-2-43	1
12-66	ZW559135	Tapping Screw #2 4x18 (PAN)		2
12-67	SK634410	Push Button Knob J	91-5051	3
12-68	TC626580	Pre Card Angle A	CW-5204	1
12-69	TC626591	Pre Card Angle B	CW-5205	1
12-70	TC626602	Slide Plate B	CW-5206	1
12-71	TC626613	REC. Plate	CW 5207	1
12-72x	ZW474603	Washer (Teflon) D4.1x13x0.2t		4
12-73	ML626624	REC. Lever	CW-5208	1
12-74	ZW290283	'U' Ring 2.85M	6-1-1	4
12-75x	EJ255032	Lug Plate VBL2	33-4-10	1
12-76x	EJ458561	Lug Plate VB2L1	33-4-2	1
12-77x	TR549022	Pause Lamp Cover	EG-5050	1
12-78	ZG469427	Spring B-1	LS-2004	1
12-79x	EJ510333	Wire Clip 220-JD481610-0104(Nylon)	2-7-17	1
12-80	SZ632417	Case Retainer	CW-5221	2
12-81x	EO464668	Ferri Inductor FL9H 470µH(K)	23-1-4	1
12-82	TC614024	Amp. Chassis R	CW-5001	1
12-83x	MZ569687	Shield Retainer	EG-5063	1
12-84	TC626646	Trans. Table B	CW-5210	1
12-85	BT623698	Trans. CWT-2	38-4-337	1
12-86x	BT623755	Power Trans. CWT-16 (CSA)	38-4-340	1
12-87x	BT623777	Power Trans. CWT-14 (JPN)	38-4-338	1
12-88x	BT623766	Power Trans. CWT-15 (CEE)	38-4-339	1
12-89x	BT634500	Power Trans. CWT-3 (310)	38-4-358	1
12-90	EZ481296	Trans. Shield, LE	LF-5034	1
12-91	EZ486617	Trans. Reinforcement Plate B	LF-5222	2
12-92	ZS447840	Tapping Screw #2 3x8 (BR)		2
12-93x	EC556435	Elect. 2200µF 25WV (Lug Type)	24-10-86	1
12-94	TC613552	Memory Retaining Plate	CW-5003	1
12-95	ES619053	Push SW. SPJ-10114B	25-5-144	1
12-96x	ZS460440	Screw, pan head 2x4		2
12-97	SB613618	Memory Button	CW 5007	1
12-98x	ER440921	Carbon/R. RD1/4 27k(J) (Insu. Type)	35-9-5	2
12-99x	ML626771	Panel Prop B	CW-5217	2
12-100	TC612112	Lamp Plate (1)	CH-5302	1
12-101	EL603268	Lamp 24V 25MA	28-2-39	1
12-102x	EZ624047	Cord Retainer	2-7-48	1
12-103	SZ632417	Case Retainer	CW 5221	1
12-104	TC484042	Retaining Foot A	CT 4001	1
12-105	EZ626286	Mic. Jack Shield	CW 5034	1
12-106	TC626501	Pre Card Angle C	CW 1202	1
12-107	TC626523	Pre Card Angle D	CW 1203	1
12-108	SK634410	Push Button Knob J	91-5051	2

When ordering parts, please describe Parts Number, Serial Number, and Model Number in detail.

FIG. 13 PHOTO OF FINAL ASSEMBLY BLOCK

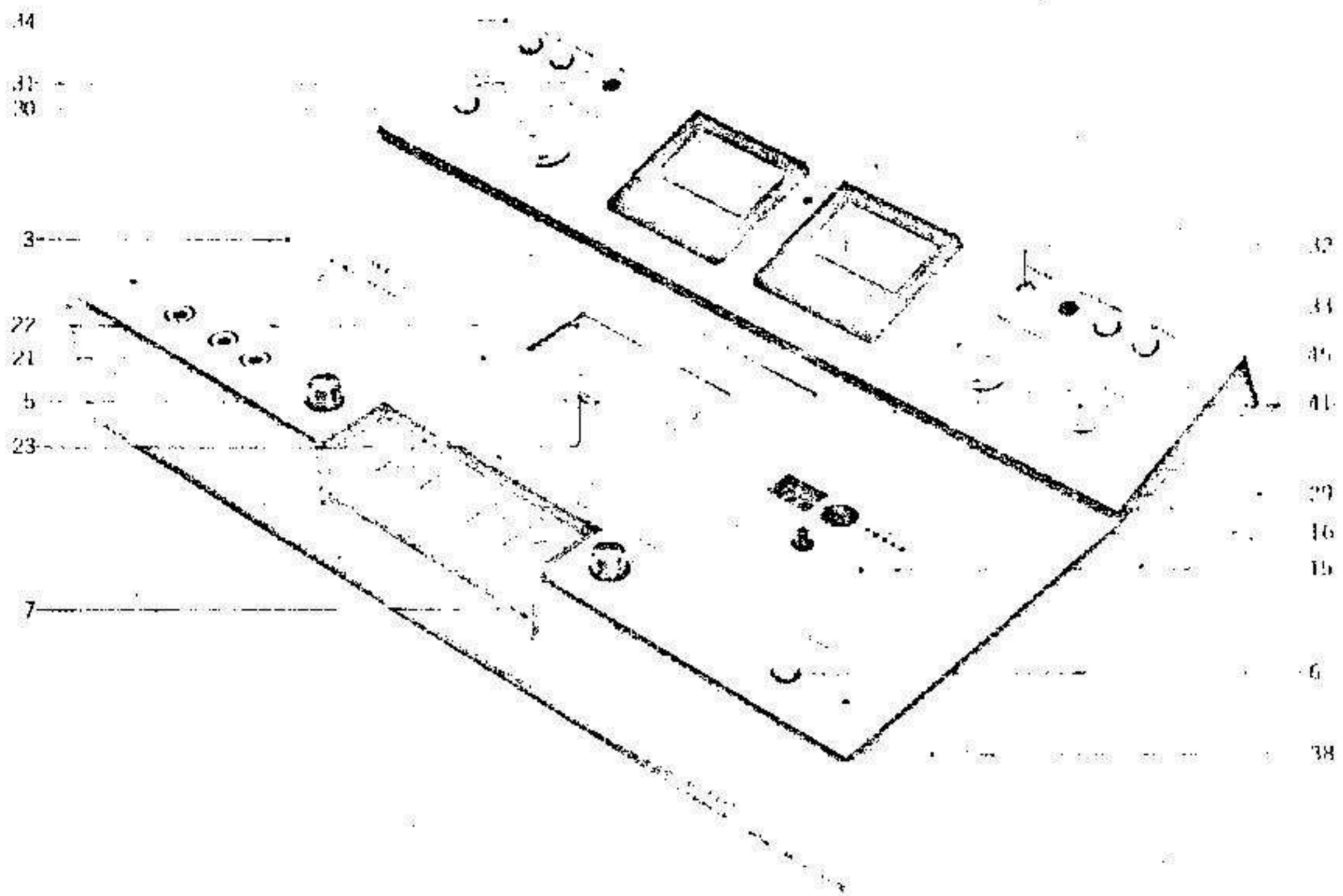

FINAL ASSEMBLY BLOCK

Ref. No.	Parts No.	Description	Schematic No.	Q'ty	Ref. No.	Parts No.	Description	Schematic No.	Q'ty
FRONT PANEL BLOCK					VU PANEL BLOCK				
13-1x	BZ623428	Front Panel Block Comp. (310D)	CW	1	13-27x	BZ623430	VU Panel Block Comp. (310D)	CW	1
13-2x	SP636118	Front Panel Block Comp. (310)	CW	1	13-28x	BZ636120	VU Panel Block Comp. (310)	CW	1
13-3	SP627434	Front Panel B	CW-6001	1	13-29	TC627816	VU Panel Table B	CW-6201	1
13-4x	SP632812	Front Panel C (310)	CW-6001	1	13-30	SE613888	Button Escutcheon A	CW-6021	5
13-5	SE613866	Button Escutcheon C	CW-6016	2	13-31	SE612055	Lamp Lens A (Red)	CH 6314	1
13-6	SE613888	Button Escutcheon A	CW-6021	1	13-32	SE612077	Lamp Lens B (Orange)	CH 6314	1
13-7	SE614204	Front Panel Escutcheon	CW-6003	1	13-33	SE628064	Lamp Lens C (Green)	CH 6314	1
13-8x	TC614057	Lid Cover Table	CW-6007	1	13-34	SP627423	VU Panel B	CW-6202	1
13-9x	ZG613798	Lid Retainer Spring	CW-6008	2	13-35x	SP627805	VU Panel C (310)	CW-6202	1
13-10x	TC613811	Shaft Table (left)	CW-6009	1	13-36x	TC613877	Panel Retainer	CW-6020	2
13-11x	TC613800	Shaft Table (Right)	CW-6009	1	13-37x	ZS325495	Tapping Screw #2 3x6		9
13-12x	ZS608275	Screw, pan head 3x5, w/washer		3	ASSEMBLY BLOCK				
13-13x	TC495123	Buffer Rubber	CG-6304	2	13-38	SZ614103	Wood Frame	CW-6023	1
13-14x	ZG613822	Cover Return Spring A	CW-6011	1	13-39x	SE614070	Jack Plate Escutcheon	CW-6024	1
13-15	SP613787	Counter Panel	CW-6005	1	13-40x	SP614114	Rear Cover	CW-6025	1
13-16	EZ586855	Tape Run Lens (Orange)	CH 6010	1	13-41	SK627783	Single Knob C	CW-6207	1
13-17x	TC614362	Counter Panel Table	CW-6004	1	13-42x	SM626758	Rear Name Plate GXC GXC-310D	CG-6510	1
13-18x	MZ618844	Stopper	CW-6012	1	13-43x	SK631078	Double Knob (Upper) (310)	MY-6206	2
13-19x	ZW290283	'U' Ring 2.85M	6-1-1	1	13-44x	SK631067	Double Knob (Lower) (310)	MY-6207	2
13-20x	ZG369112	Head Base Return Spring	HCC-1035	1	13-45	SK631056	Single Knob	MY-6208	2
13-21	SP613855	Lid Cover Panel	CW-6014	1	13-46x	SK639022	Single Knob D (310)	CW-6210	1
13-22	TC614068	Case Lid	CW-6013	1	13-47x	SK634410	Push Button Knob J	91-5051	2
13-23	SM548310	Name Plate (GX) B	CG-6411	1					
13-24x	SE613912	Mask A	CW-6032	2					
13-25x	SE613923	Mask B	CW-6032	2					
13-26x	TC606420	Meter Mask	CH-5029	1					

When ordering parts, please describe Parts Number, Serial Number, and Model Number in detail.

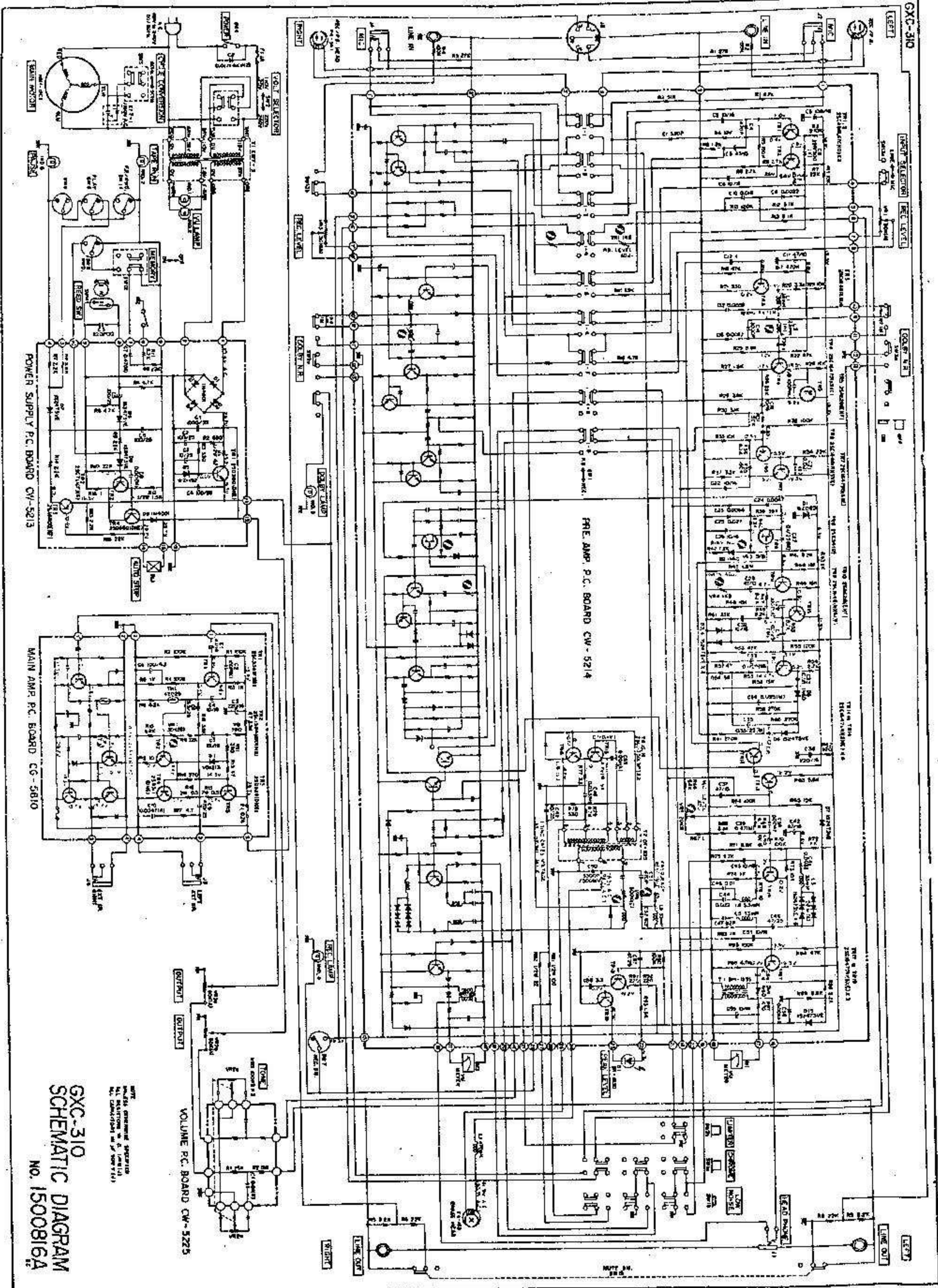

GXC-310
SCHEMATIC DIAGRAM
NO. 1500816A

NOTE: ALL COMPONENTS SHOWN ARE STANDARD UNLESS OTHERWISE SPECIFIED.