

# TA-F3A

*US Model*  
*Canadian Model*  
*UK Model*  
*AEP Model*  
*E Model*



(AEP, UK, E Model)

**INTEGRATED STEREO AMPLIFIER**

## SPECIFICATIONS

### GENERAL

<b>Power Requirements:</b> 120V ac, 60 Hz (US, Canadian Model) 220 V ac, 50/60 Hz (AEP Model) 240 V ac, 50/60 Hz (UK Model) 120 or 220V ac adjustable. 50/60 Hz (E Model)	<b>Weight:</b> Approx. 10.5 kg (23 lb 2oz). net Approx. 12.5 kg (27 lb 9 oz), in shipping carton (US, Canadian Model) Approx. 9.5 kg (21 lb), net Approx. 11.5 kg (25lb 6oz), in shipping carton (AEP, UK, E Model)
---	---

**Power Consumption:**  
 85W (US Model)  
 140W (Canadian Model)  
 210W (AEP, E Model)  
 240W (UK Model)

### AMPLIFIER SECTION

<b>Dimensions:</b> Approx. 435 (w) x 145 (h) x 370 (d) mm 17 1/8 (w) x 5 3/4 (h) x 14 5/8 (d) inches (US, Canadian Model) Approx. 410 (w) x 145 (h) x 370 (d) mm 16 1/4 (w) x 5 3/4 (h) x 14 5/8 (d) inches (AEP, UK, E Model) Including projecting parts and controls	<b>Continuous RMS Power output:</b> (Less than 0.5% THD) Both channels driven simultaneously At 1 kHz 50W+50W (8 Ω) At 20 Hz-20 kHz 50 W + 50 W (8 Ω) According to DIN 45500 (AEP, UK, E Model) 52W+52W (8 Ω)
---	---

**SAFETY-RELATED COMPONENT WARNING!!**  
 COMPONENTS IDENTIFIED BY SHADING AND **A** MARK ON THE SCHEMATIC DIAGRAMS, EXPLODED VIEWS AND IN THE PARTS LIST ARE CRITICAL TO SAFE OPERATION. REPLACE THESE COMPONENTS WITH SONY PARTS WHOSE PART NUMBERS APPEAR AS SHOWN IN THIS MANUAL OR IN SUPPLEMENTS PUBLISHED BY SONY.

<b>Power Bandwidth (IHF):</b> Damping Factor: Harmonic Distortion: IM Distortion: (60 Hz: 7 kHz = 4:1)	10 Hz-25 kHz 30 Less than 0.5% at rated output Less than 0.1% at 1 W output Less than 0.5% at rated output Less than 0.1% at 1W output
--	---

ATTENTION AU COMPOSANT AVANT RAPPORT

# SECTION 1 OUTLINE

## 1-1. BLOCK DIAGRAM

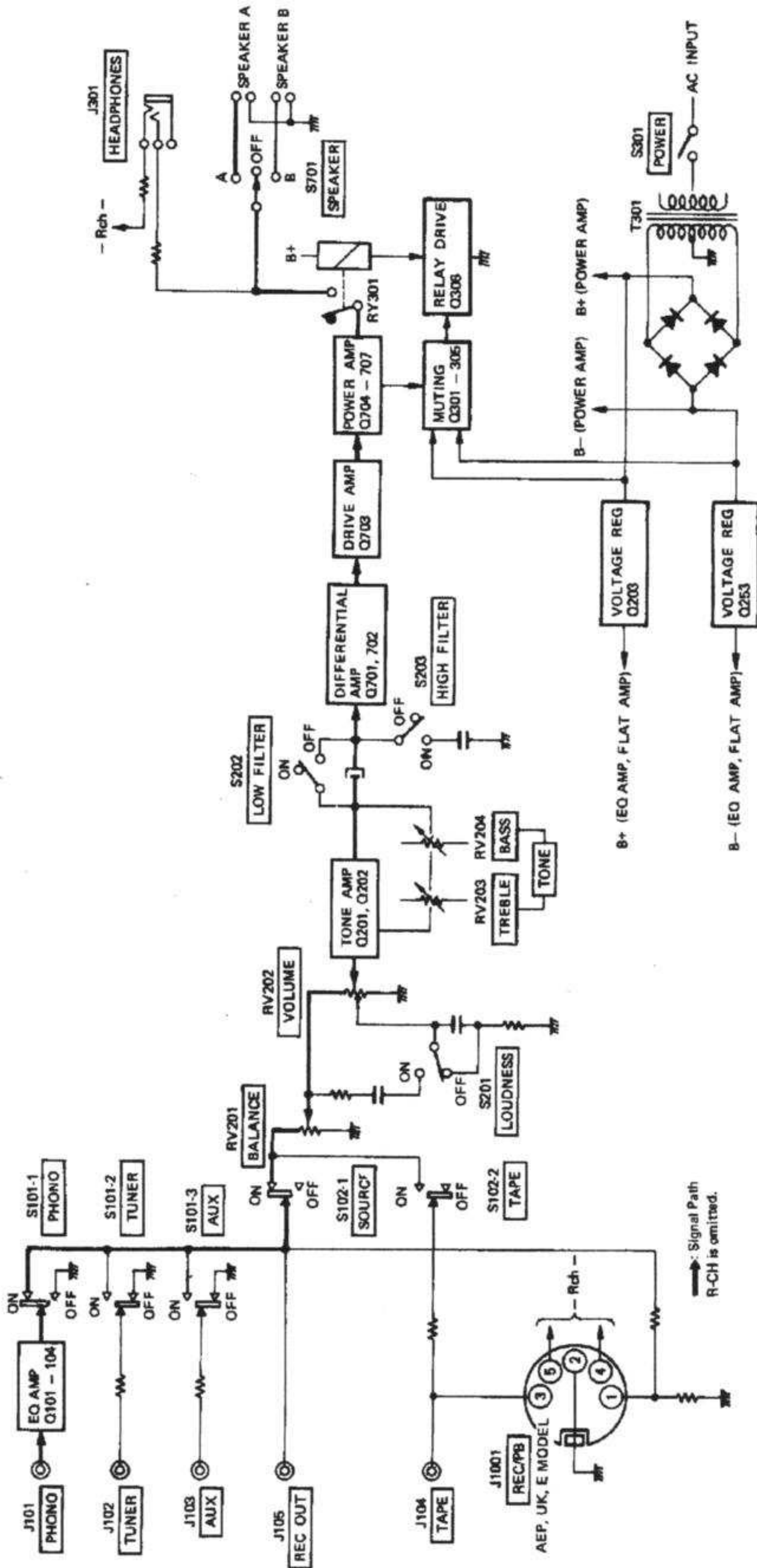

1-2. CIRCUIT DESCRIPTION

PROTECTION CIRCUIT

Two kinds of protection circuit are employed in this power amplifier. One is a power-transistor protection circuit and the other is a speaker protection circuit.

1. Power-transistor Protection Circuit

To protect overloaded power transistors from destruction, a protection circuit is employed. The fusible resistors are inserted in each of Q704, 4705 (L-CH) and 4754, 4755 (R-CH) collector and emitter circuits. When the excessive current flows into the power transistors, these fusible resistors break faster than the transistors and thus protects the transistors from destruction.

2. Speaker Protection Circuit (See Fig. 1-1 and Fig. 1-2)

- When the excessive current flows into the power transistors, B+ voltage decreases. Therefore, 4301 turns on, biasing the base of Q302, and Q302 conducts. This removes the bias voltage at the base of Q306 and Q306 turns off. The relay is not activated by off state of Q306. Accordingly, the speaker is cut off from the amplifier circuit.
- When the positive dc component presents at the speaker output terminal, C310 is charged up as shown in Fig. 1-2. Q303 turns on, Q306 turns off and the relay RY301 is not activated (4304 remains in off condition). Also, when the negative dc component presents, C3 11 is charged up. This turns 9304 on, Q306 off and RY301 is not activated (9303 remains in off condition).

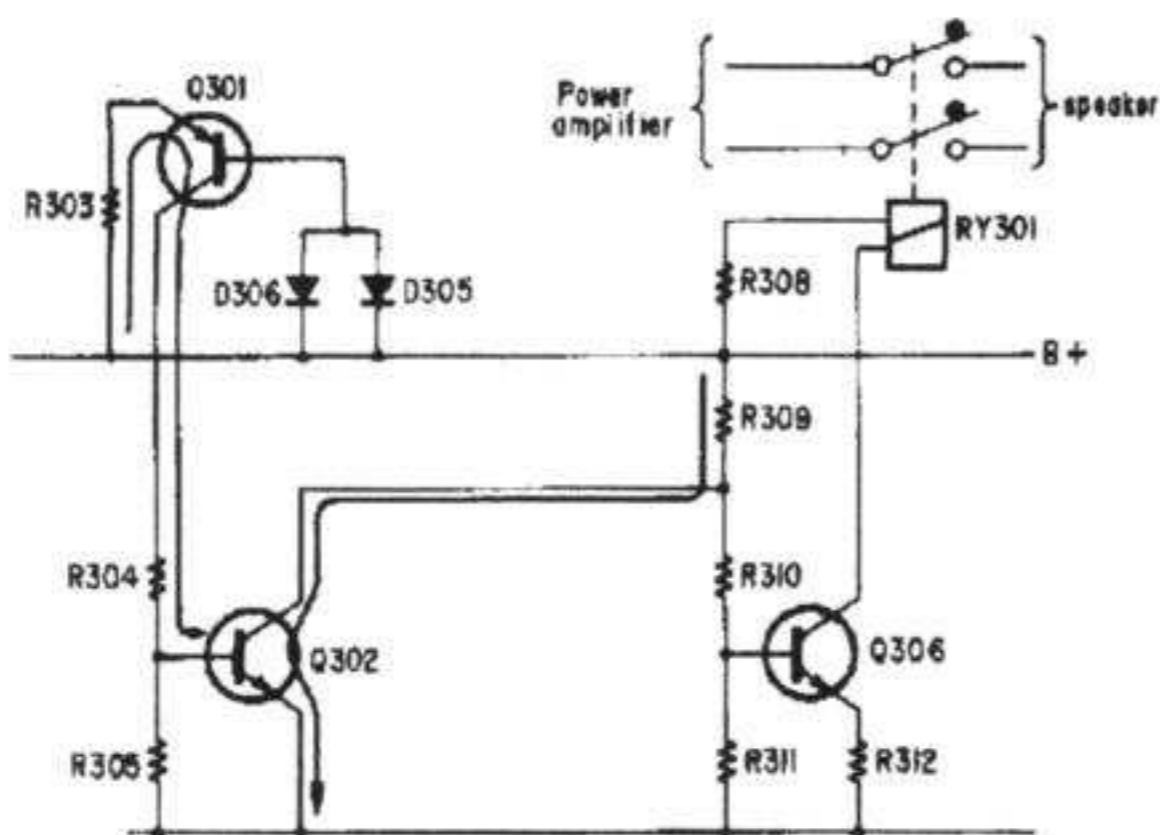

Fig. 1-1.

3. Muting Circuit (See Fig. 1-3 and Fig. 1-4)

This muting circuit prevents the loud "pop" (due to initial current flow) or click noises produced just after turning the POWER switch to on or off. These transients might damage a delicate high-fidelity speaker system.

When POWER Switch turned on:

C308 commences to charge through R309. At the same time, the base voltage of Q306 gradually rises in accordance with charging voltage of C308. It takes about 3 seconds until Q306 is turned on. Accordingly, the speaker output terminal is cut off by the relay RY301 for about 3 seconds after the POWER switch is turned on. This protects the speaker from the destruction caused by the "pop" noises.

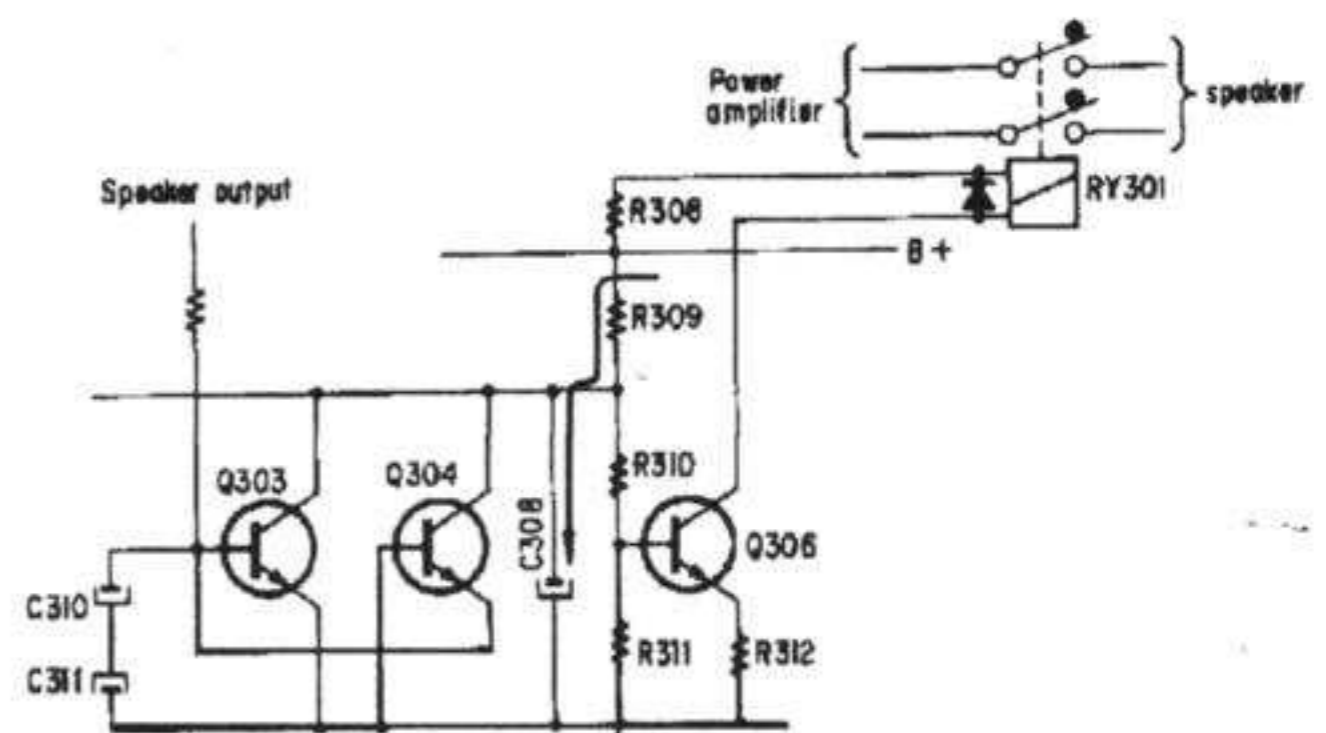

Fig. 1-2.

When POWER Switch turned off:

The reverse voltage (about -1.7 V) that turns off Q306 immediately reduces, and the positive potential is applied to the base of Q305. Q305 turns on and Q306 turns off, cutting off the operation of RY301. Therefore, no pop noise presents on the speaker output.

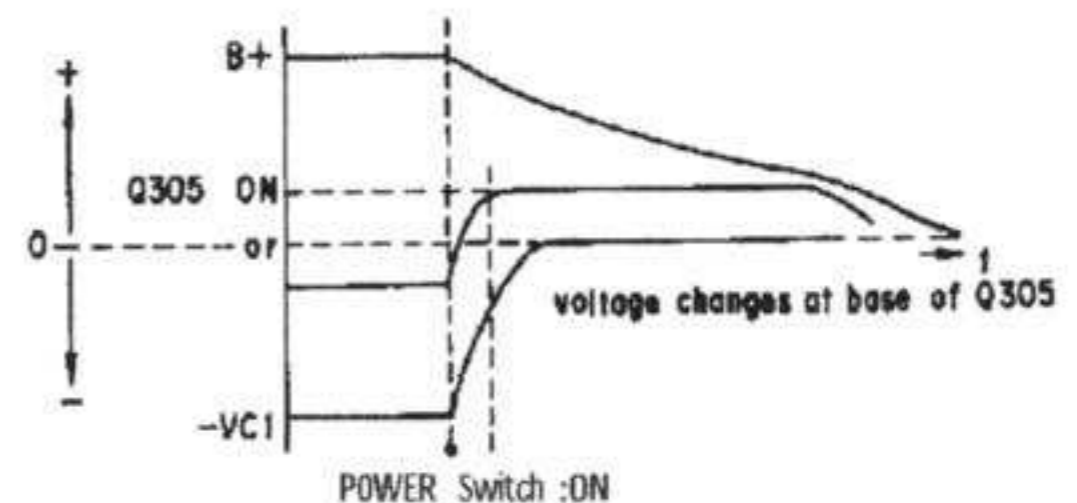

Fig. 1-3.

**SECTION 4  
DIAGRAMS**

Note: The components identified by shading and ⚠ mark are critical for safety. Replace only with part number specified.

**4-1. SCHEMATIC DIAGRAM**

Replacement Semiconductors.

For replacement, use semiconductors except in ( ) .

<p><b>Q102, 152: 2SC1345</b> (2SC1222E)</p>	<p><b>Q701, 702, 751, 752: 2SA872-E</b> (2SA640F)</p>
<p><b>Q101, 151: 2SA872-E</b> (2SA750E)</p>	<p><b>Q703, 753: 2SC1811</b> (2SC1940L)</p>
<p><b>Q103, 153, 2SC1475</b> <b>Q203, 306: (2SC2002L)</b></p>	<p><b>Q104, 154, 2SA772-23</b> <b>Q253: (2SA953L)</b></p>
<p><b>Q201, 251: 2SA872-E</b> (2SA991F)</p>	<p><b>Q704, 754: 2SD667</b> (2SD414R)</p>
<p><b>Q202, 252: 2SC1345</b> (2SC1844F)</p>	<p><b>Q705, 755: 2SB647</b> (2SB548R)</p>
<p><b>Q301: 2SA678</b> (2SA733P)</p>	<p><b>Q706, 756: 2SA771</b> <b>(2SA771-0)</b></p>
<p><b>Q302-305: 2SC1345</b> (2SC945P)</p>	<p><b>D305, 306: 1S1555</b> <b>(ISS53)</b></p> <p><b>D308: 1S2076A</b> <b>(ISS54)</b></p> <p><b>D309: 10E2</b> <b>(10E1)</b></p>
<p><b>D301-304: U05G</b> (30D2)</p>	<p><b>D201, 251: EQB01-22</b> (RD22EB)</p>
<p><b>D310: SEL103R</b></p>	

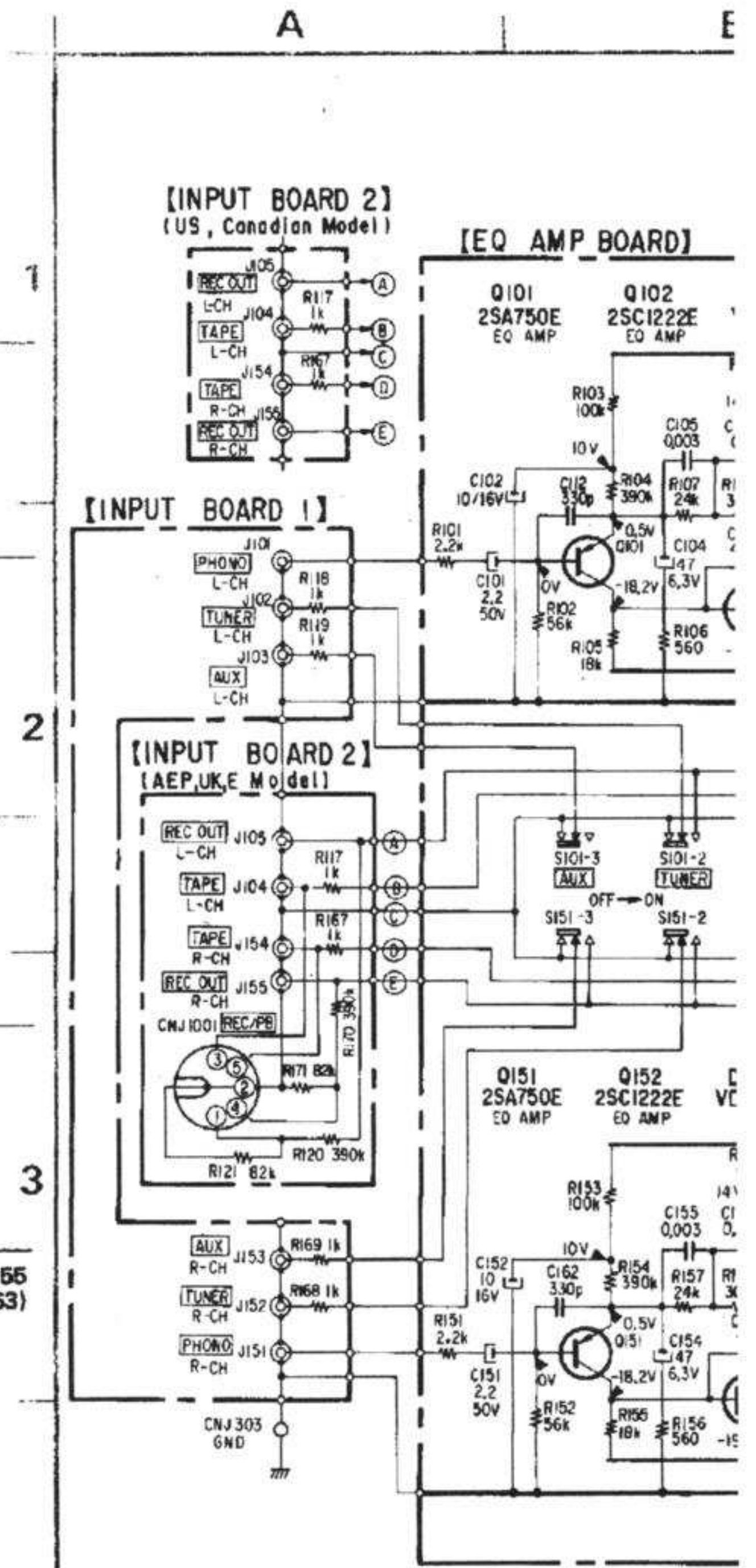

**Note:**

- All capacitors are in  $\mu\text{F}$  unless otherwise not 50 WV or less are not indicated except for el
- All resistors are in ohms,  $\frac{1}{4}\text{W}$  unless oth  $\text{k}\Omega = 1000\Omega$ ,  $\text{M}\Omega = 1000\text{k}\Omega$
- : fusible resistor;
- : panel designation.
- : adjustment for repair.
- : B+ bus.
- : B- bus.
- Readings are taken under no signal cond VOM (20  $\text{k}\Omega/\text{V}$ ).

mark  
number

Note: Les composants identifiés par un trame et une marque sont critiques pour la sécurité. Ne les remplacer que par une pièce portant le numéro spécifié.

B

C

D

E

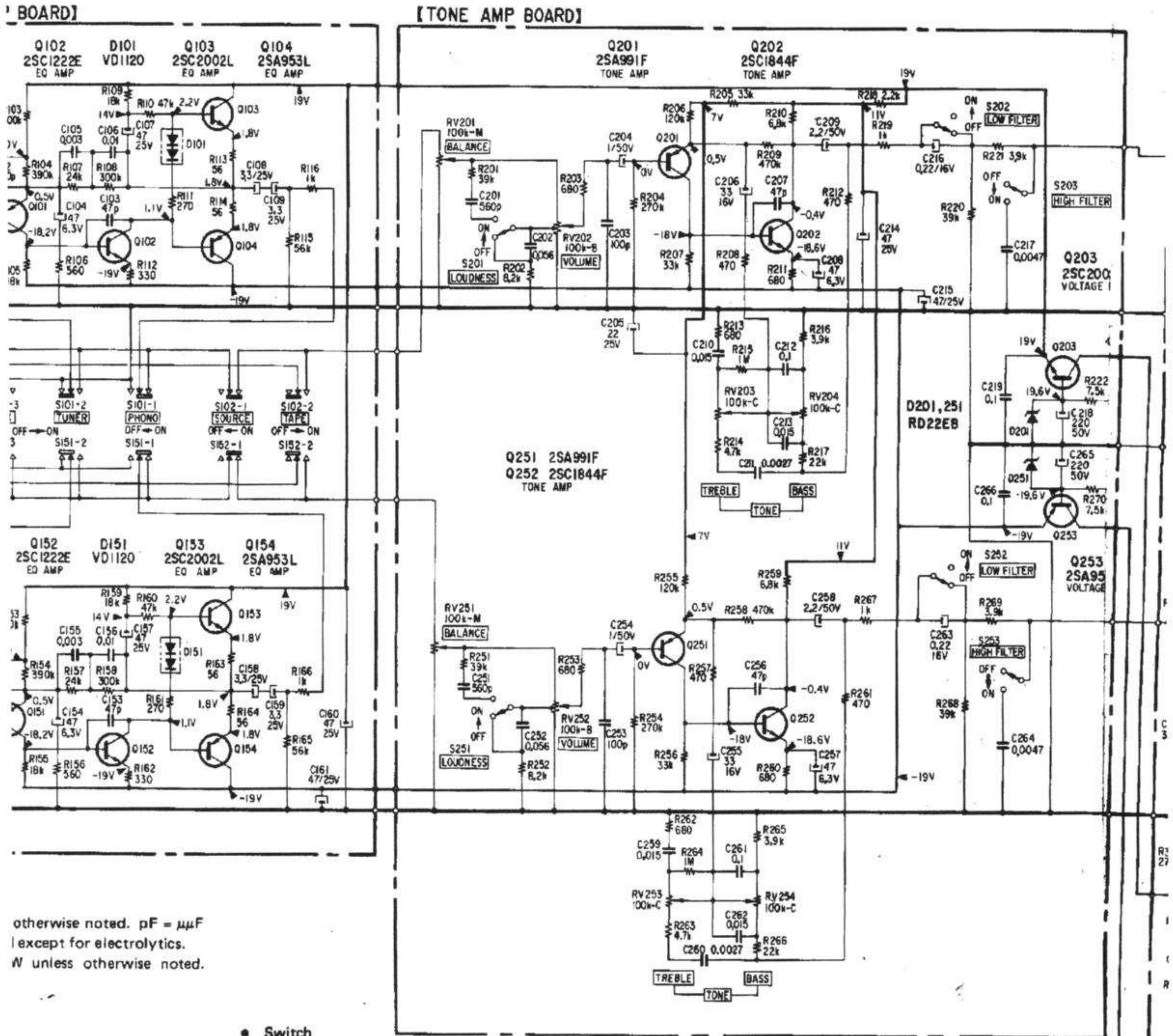

otherwise noted. pF =  $\mu\mu\text{F}$   
| except for electrolytics.  
W unless otherwise noted.

• Switch

Ref. No.	Switch	Position
S101, 151	FUNCTION	PHONO
S102, 152	MONITOR	SOURCE
S201, 251	LOUDNESS	OFF
S202, 252	LOW FILTER	OFF
S203, 253	HIGH FILTER	OFF
S301	POWER	OFF
S701	SPEAKERS	A

signal conditions with a

## [POWER AMP BOARD]

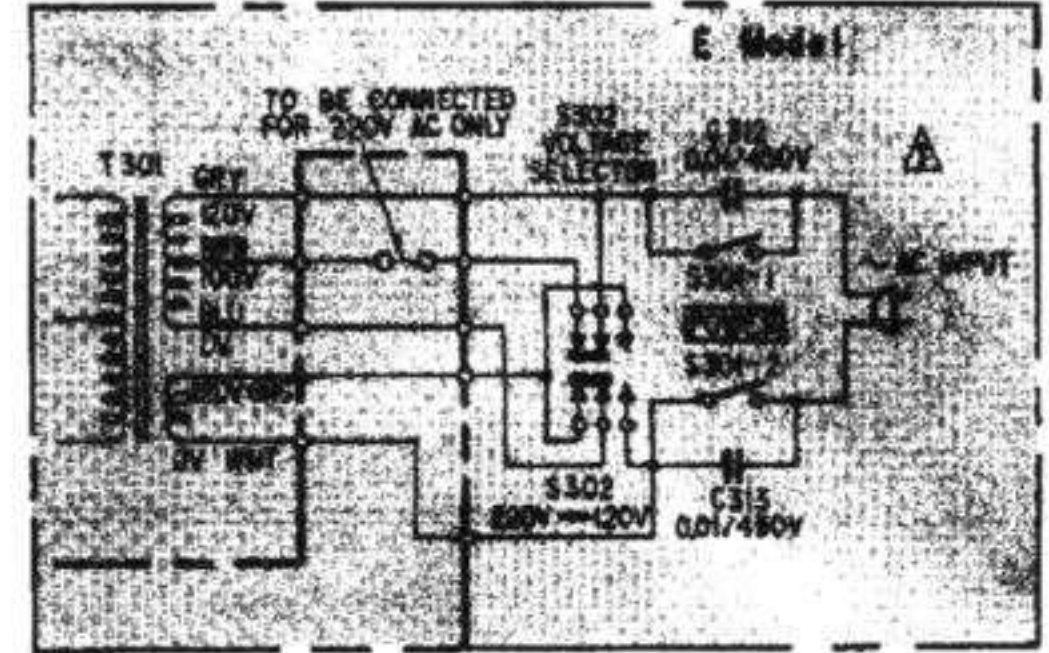
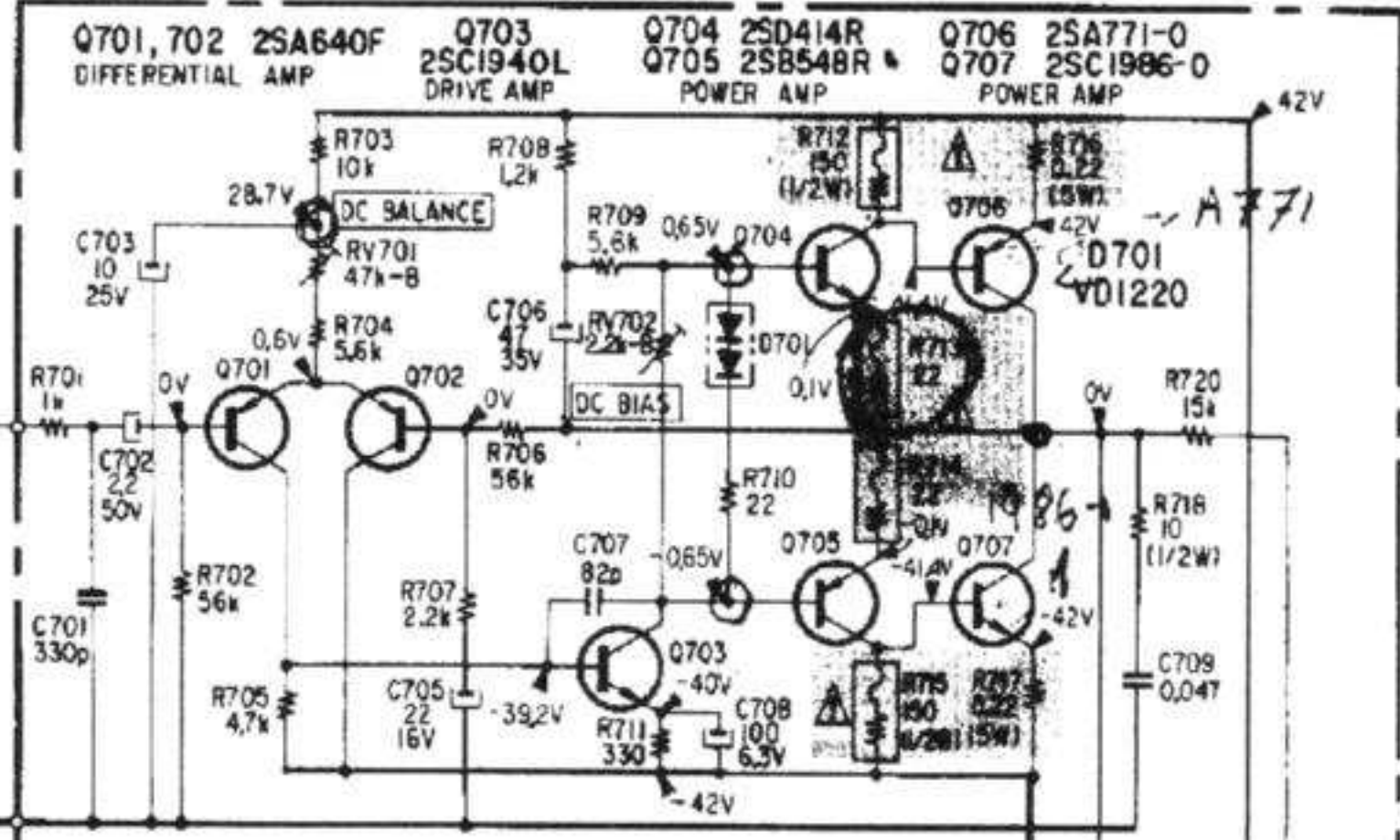

## [SPEAKER BOARD]

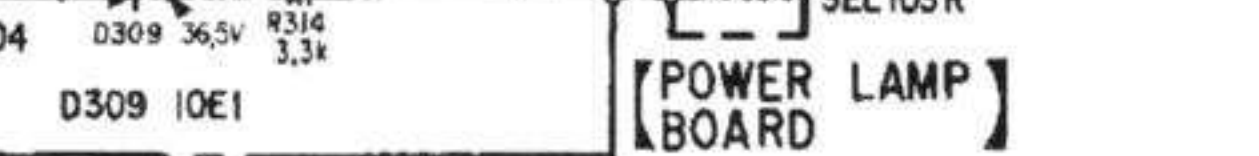
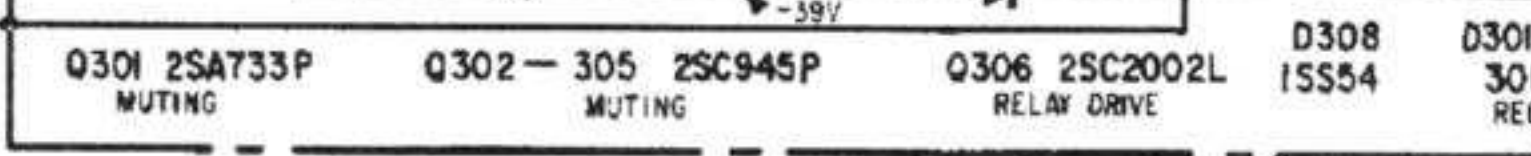
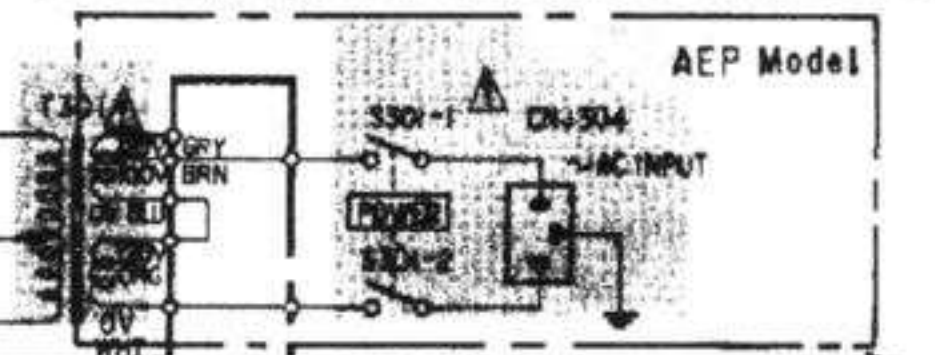
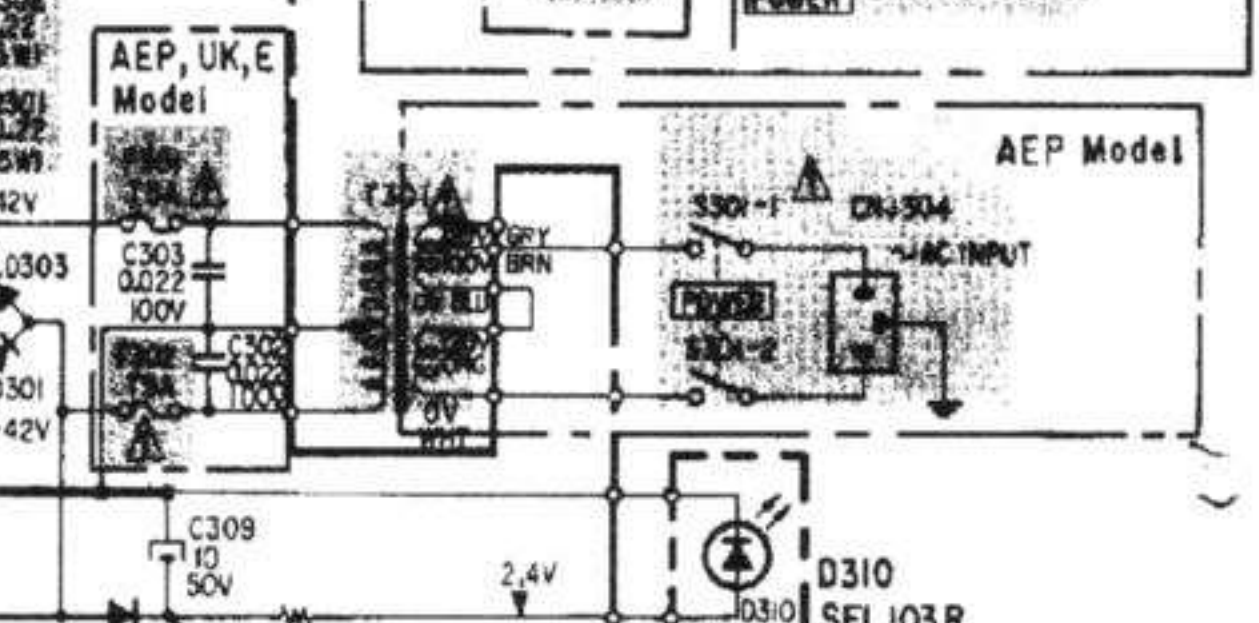
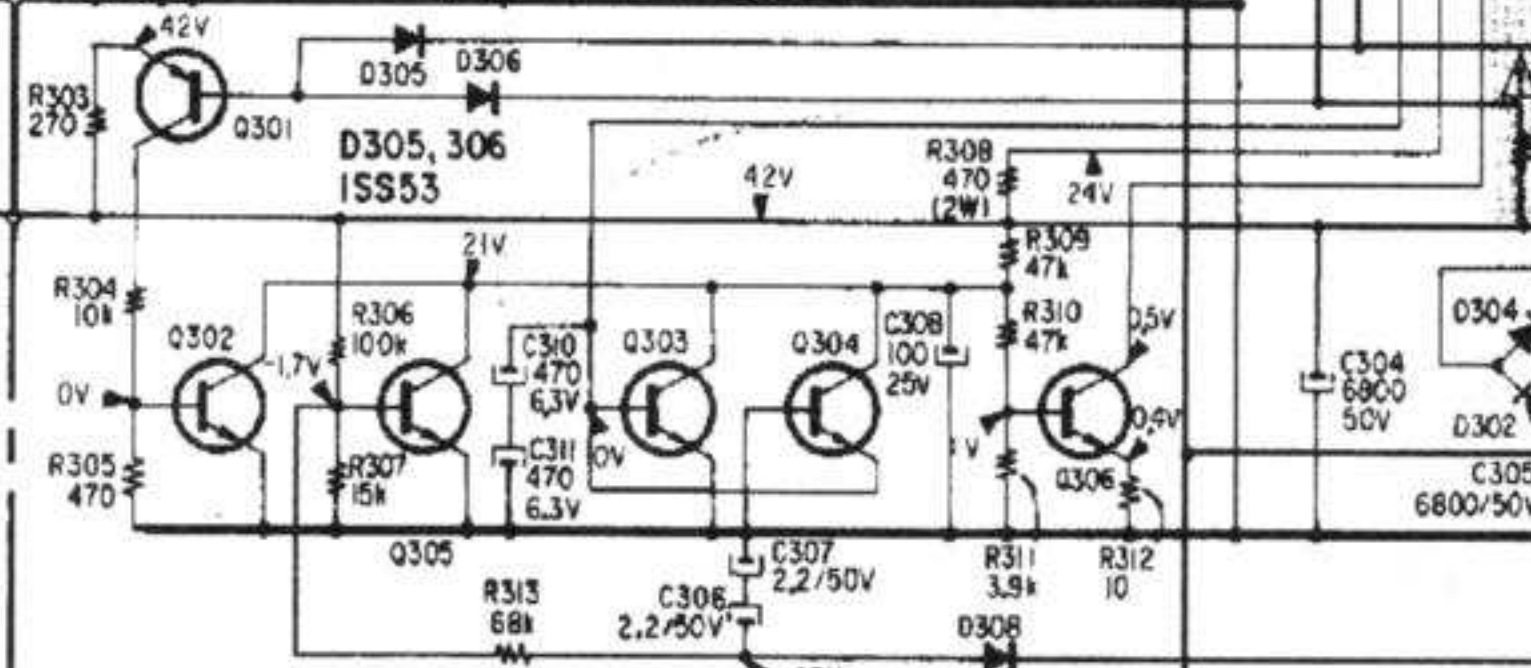
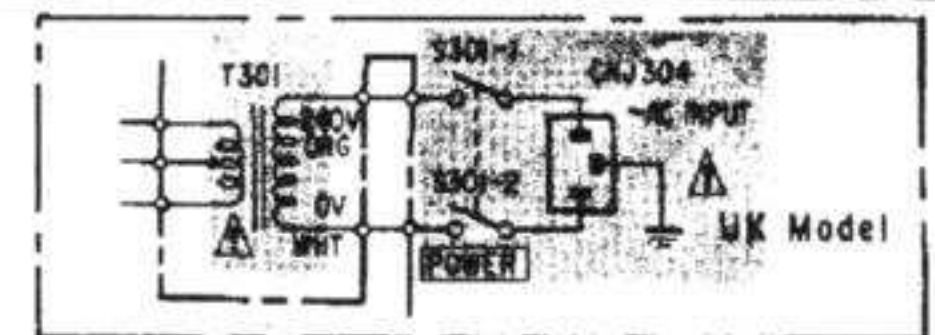
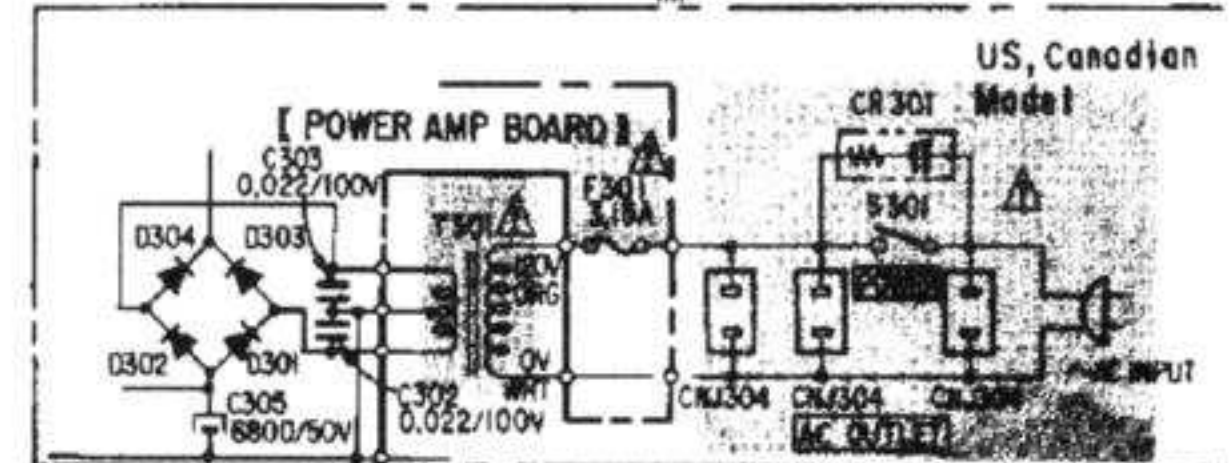
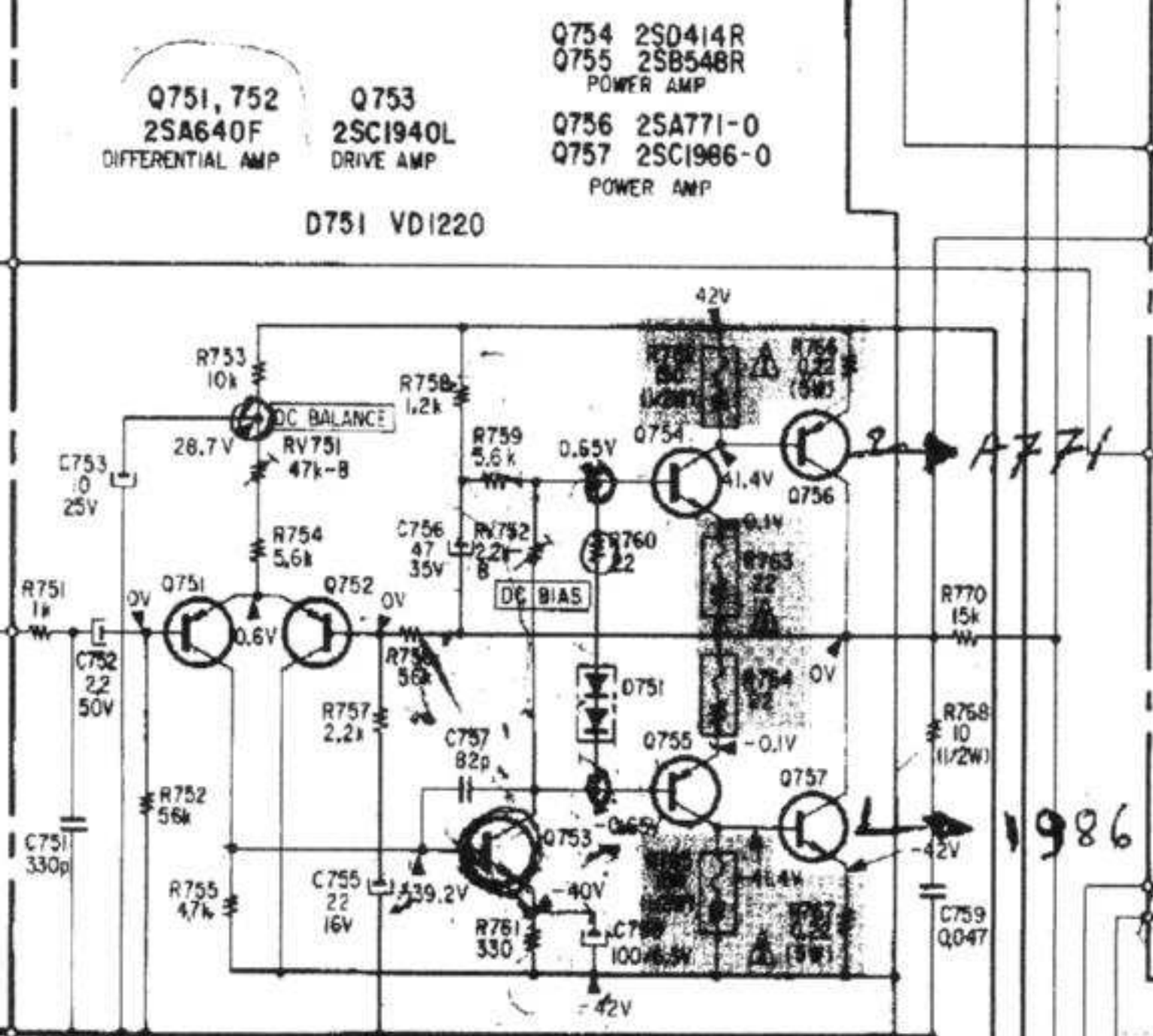
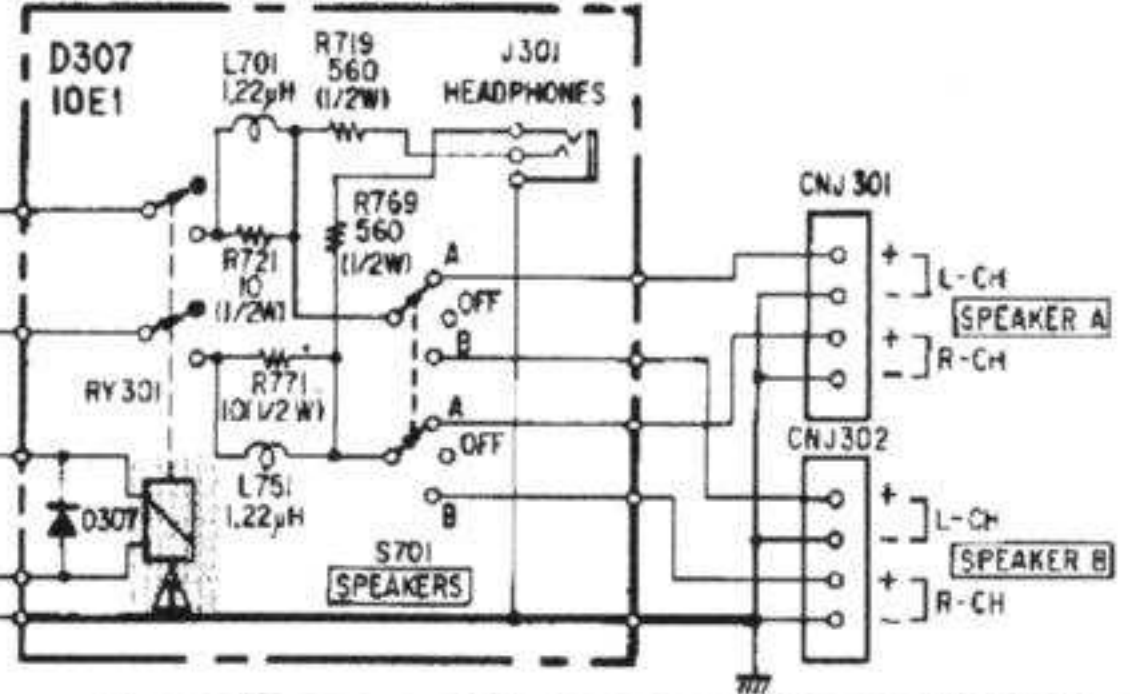

- Q301 2SA733P MUTING
- Q302-305 2SC945P MUTING
- Q306 2SC2002L RELAY DRIVE
- D308 ISS54
- D301-304 30D2 RECT
- D309 10E1

**[ POWER AMP BOARD ]**

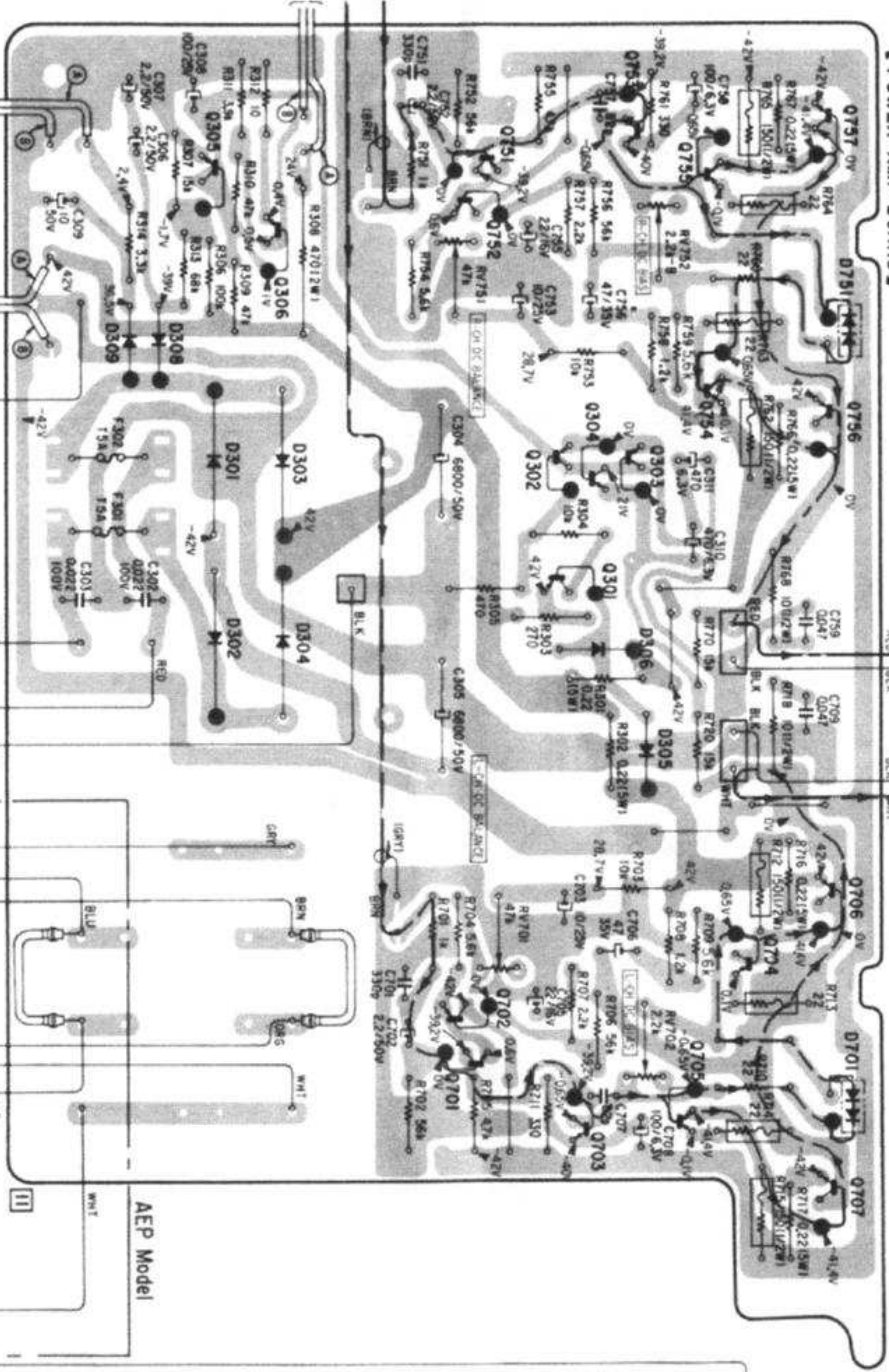

**[ POWER LAMP BOARD ]**

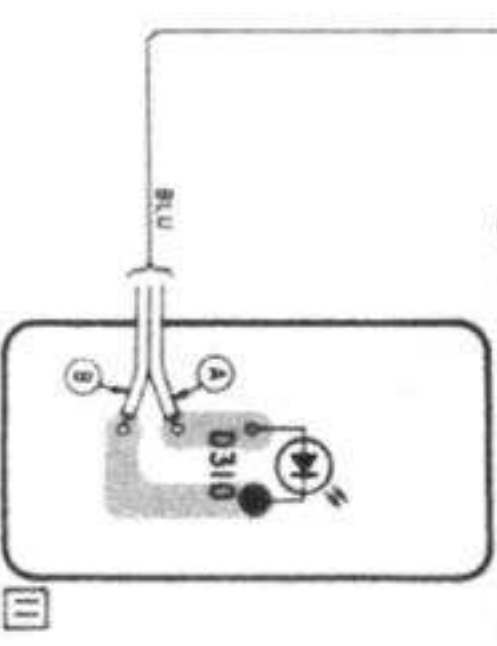

US, Canadian, UK Model (See page 15.)

**AEP Model**

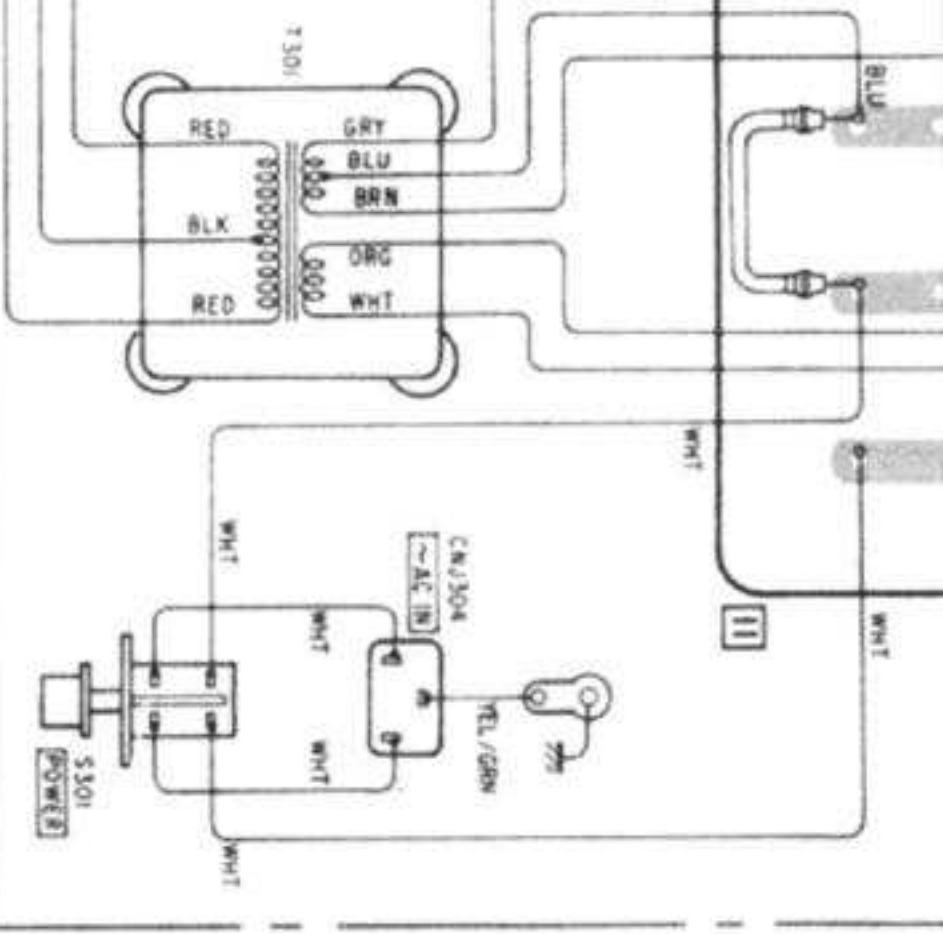

**[ SPEAKER BOARD ]**

— New —

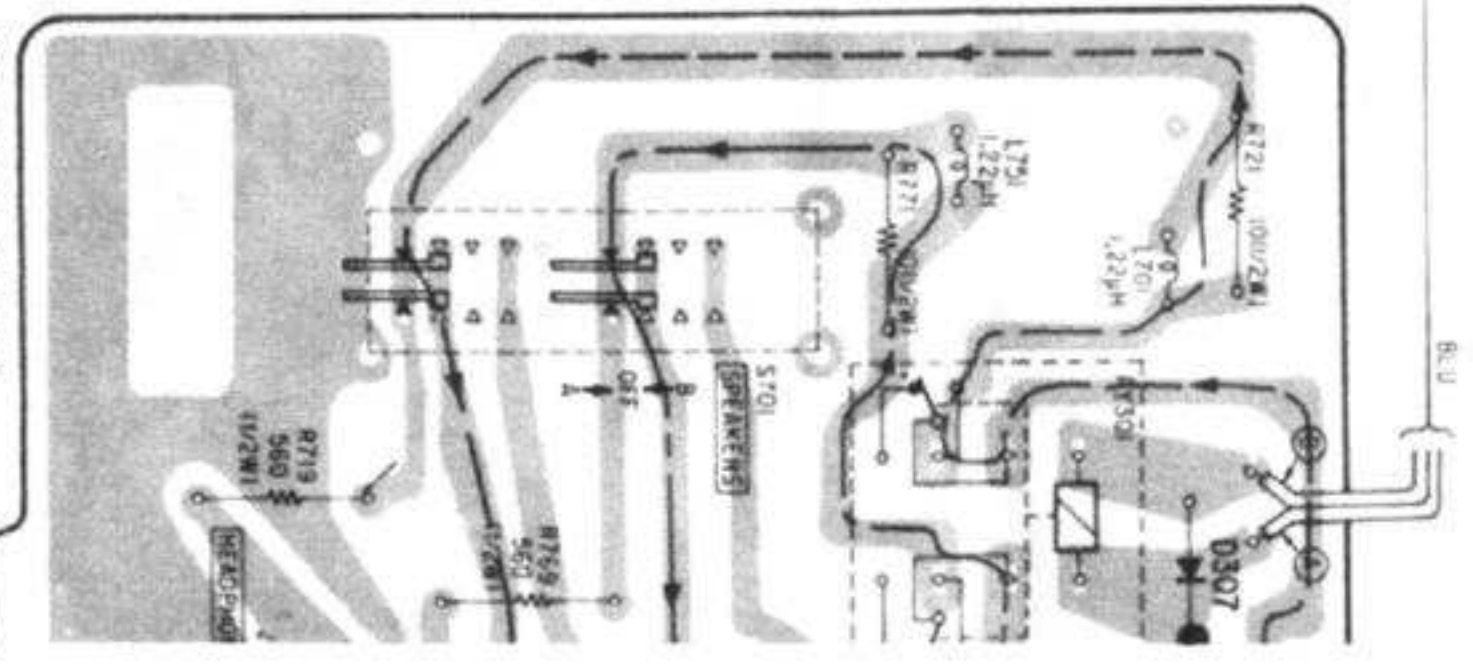



**[TONE AMP BOARD] - Conductor Side -**

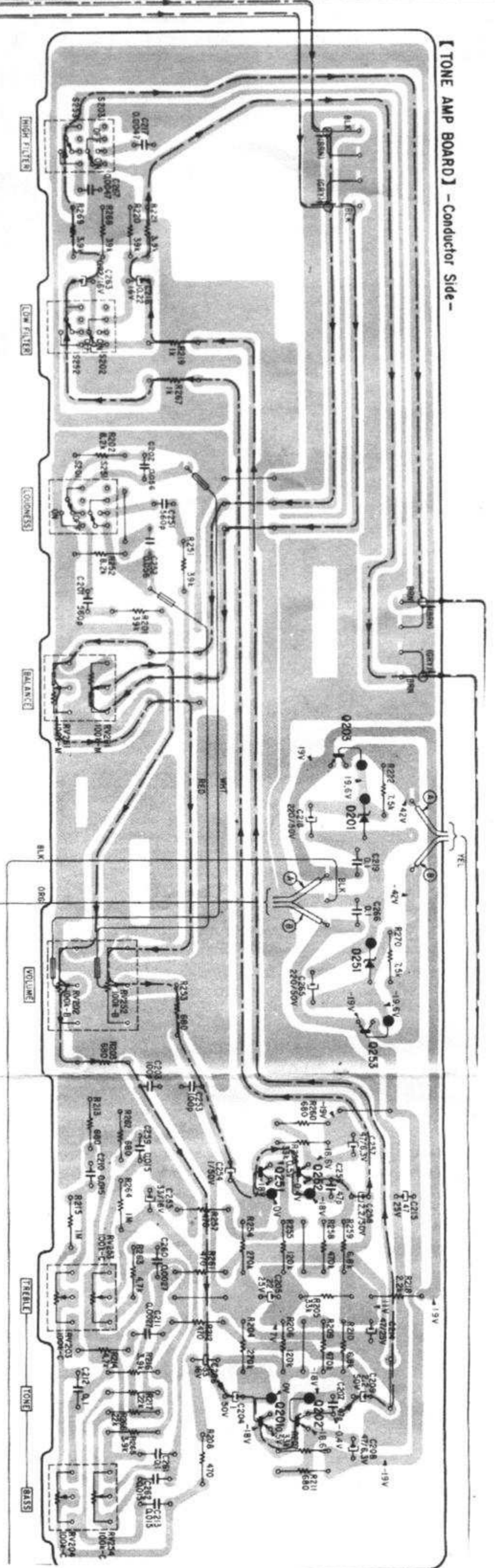

**[EO AMP BOARD] - Component Side -**

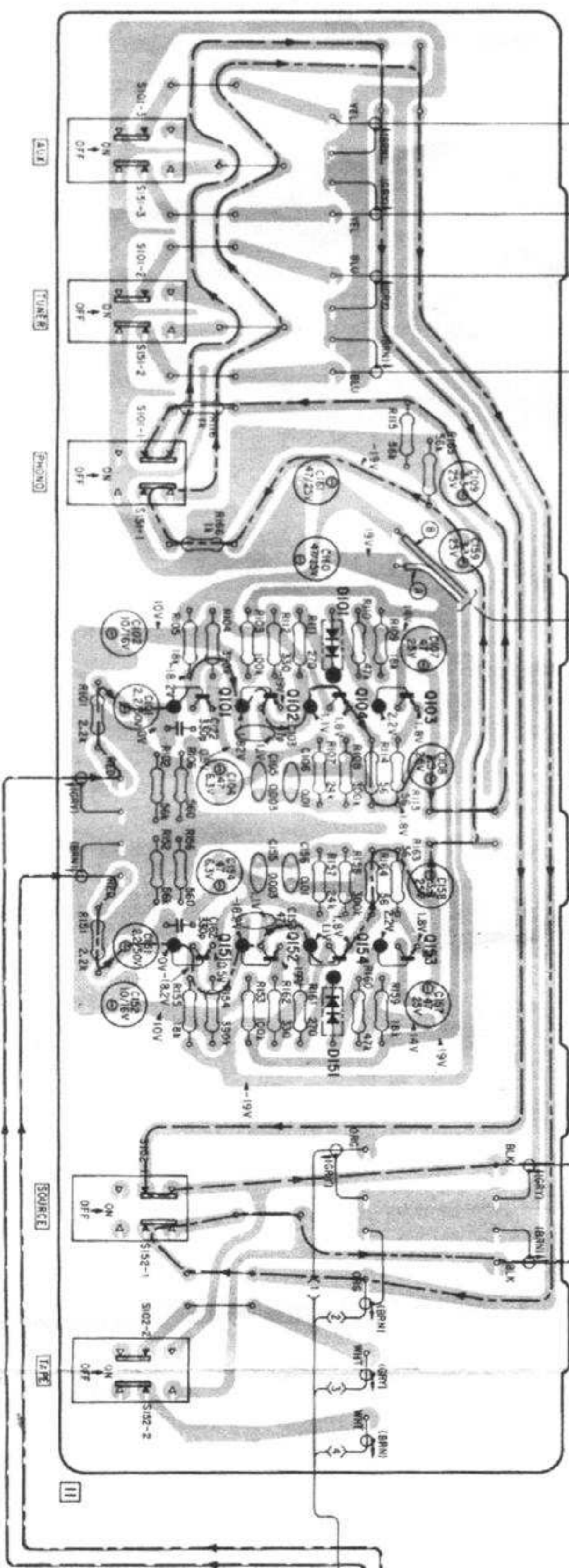

**[INPUT BOARD 1] - Conductor Side -**

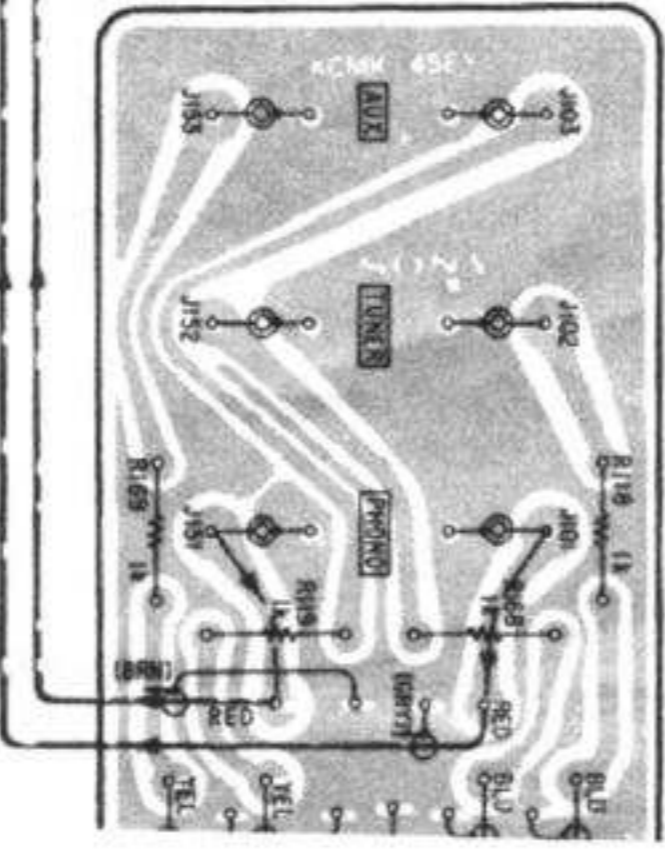

**[INPUT BOARD 2] - Conductor Side -**

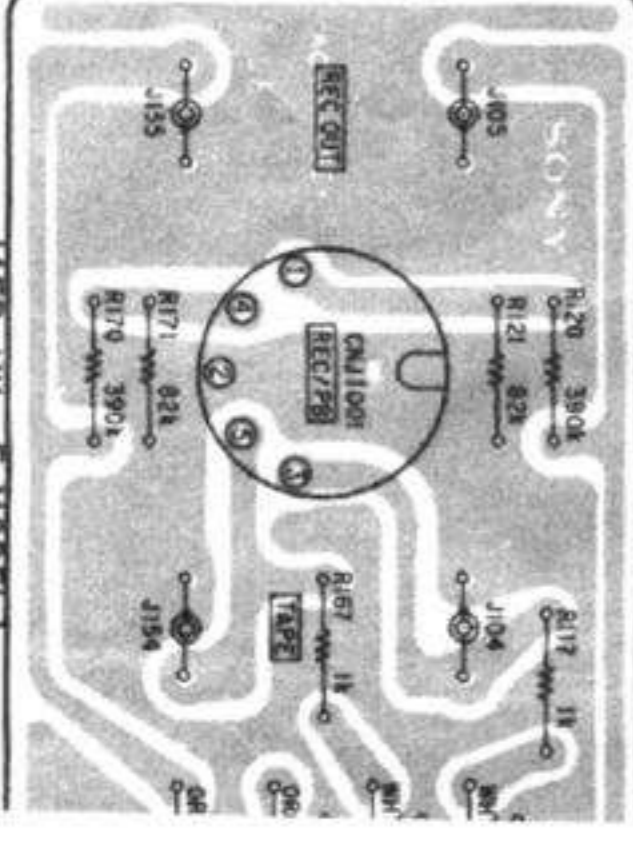

(AEP, UK, E MODEL)

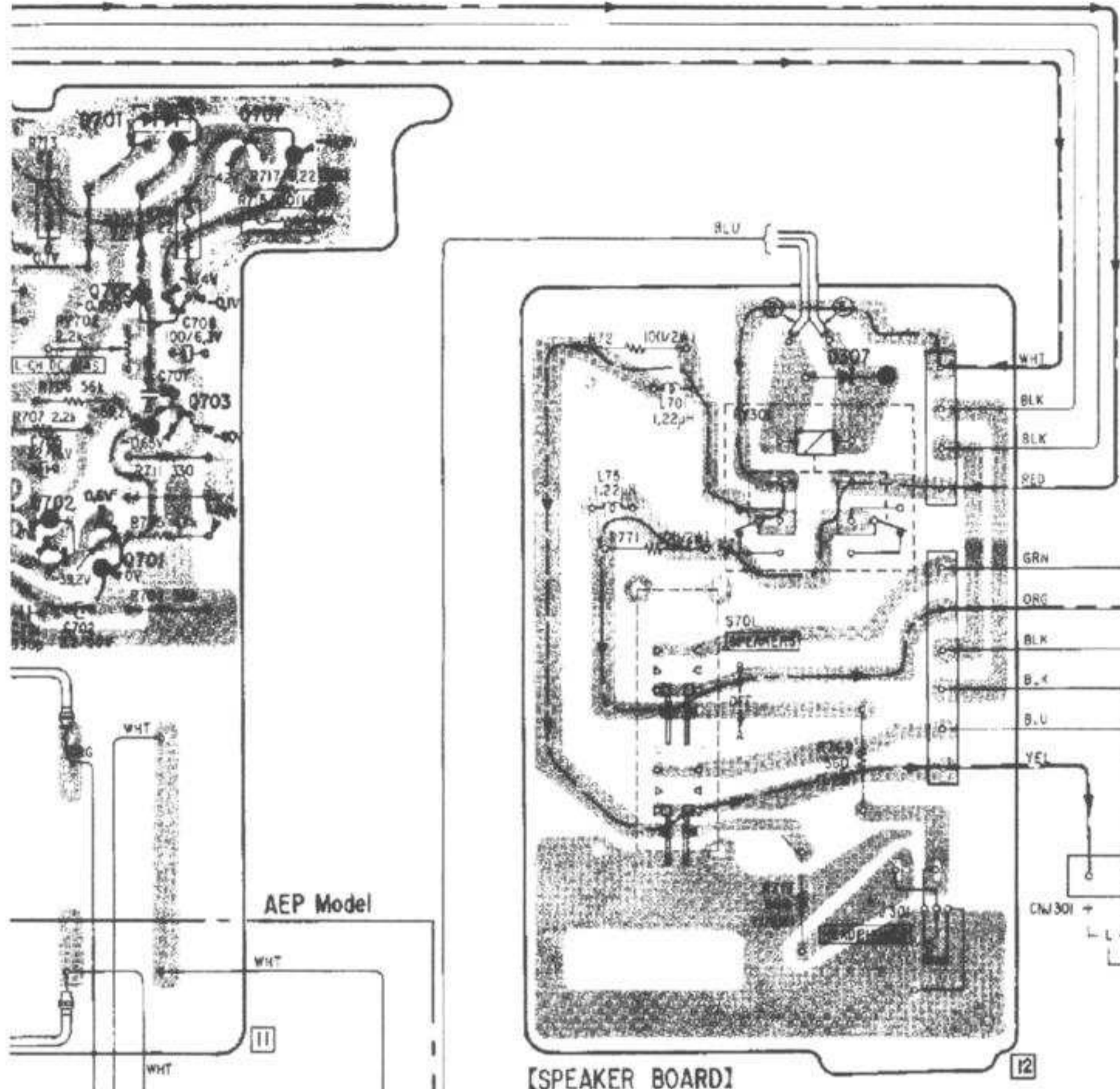

[SPEAKER BOARD]  
- New -

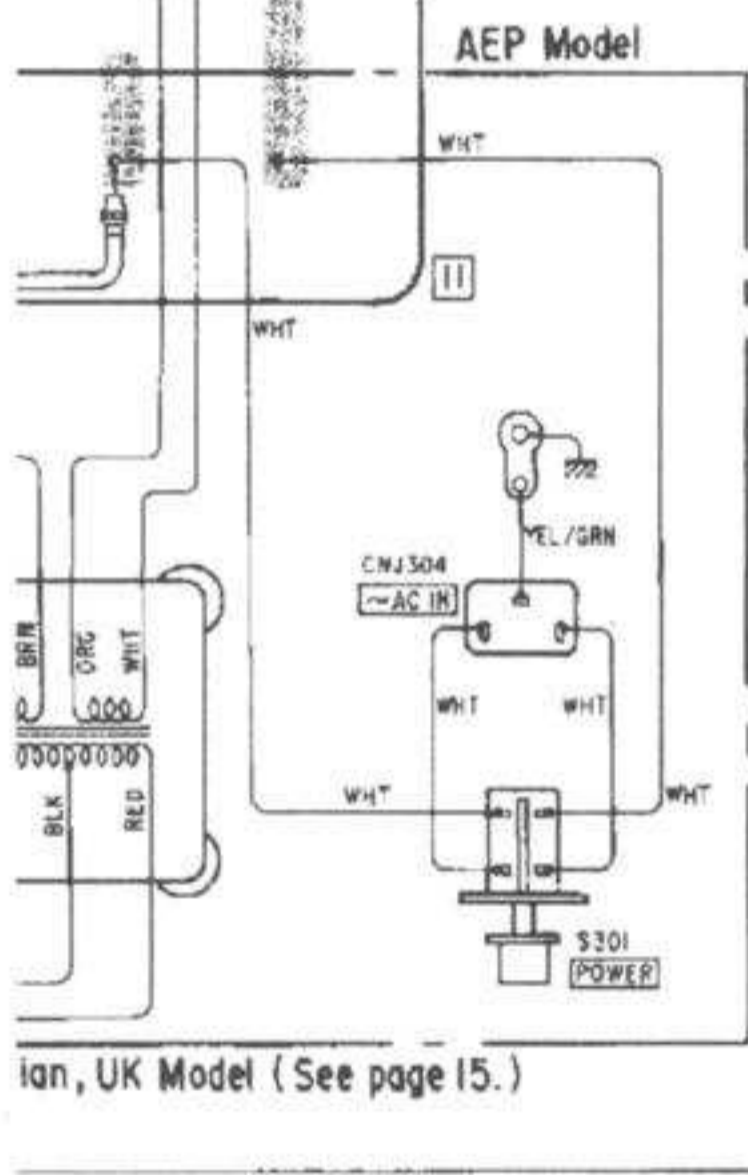
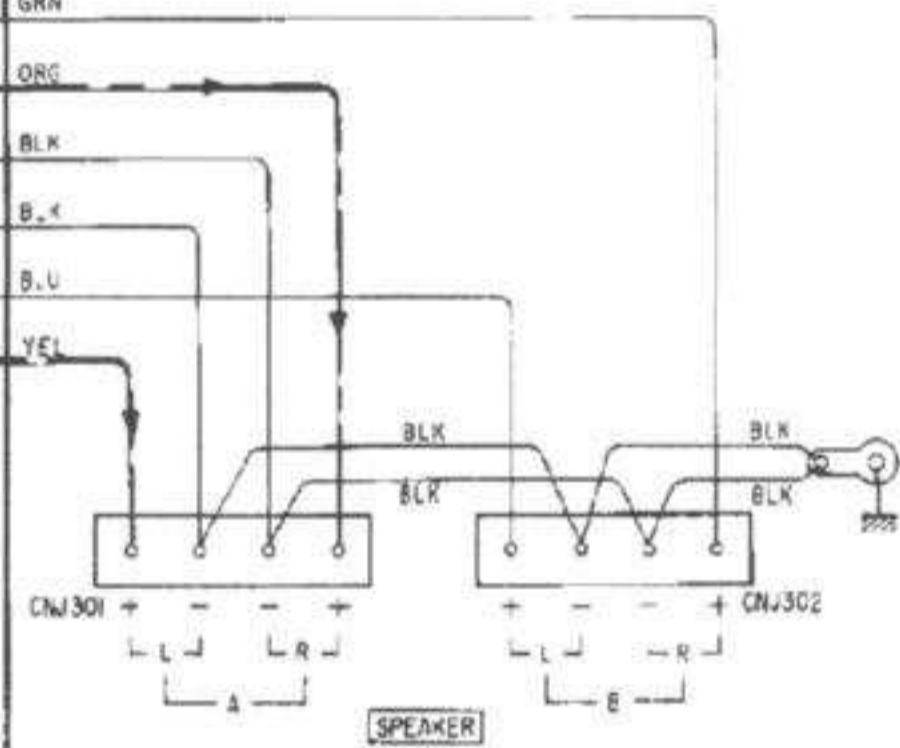

AEP Model

lan, UK Model ( See page 15. )

E Model

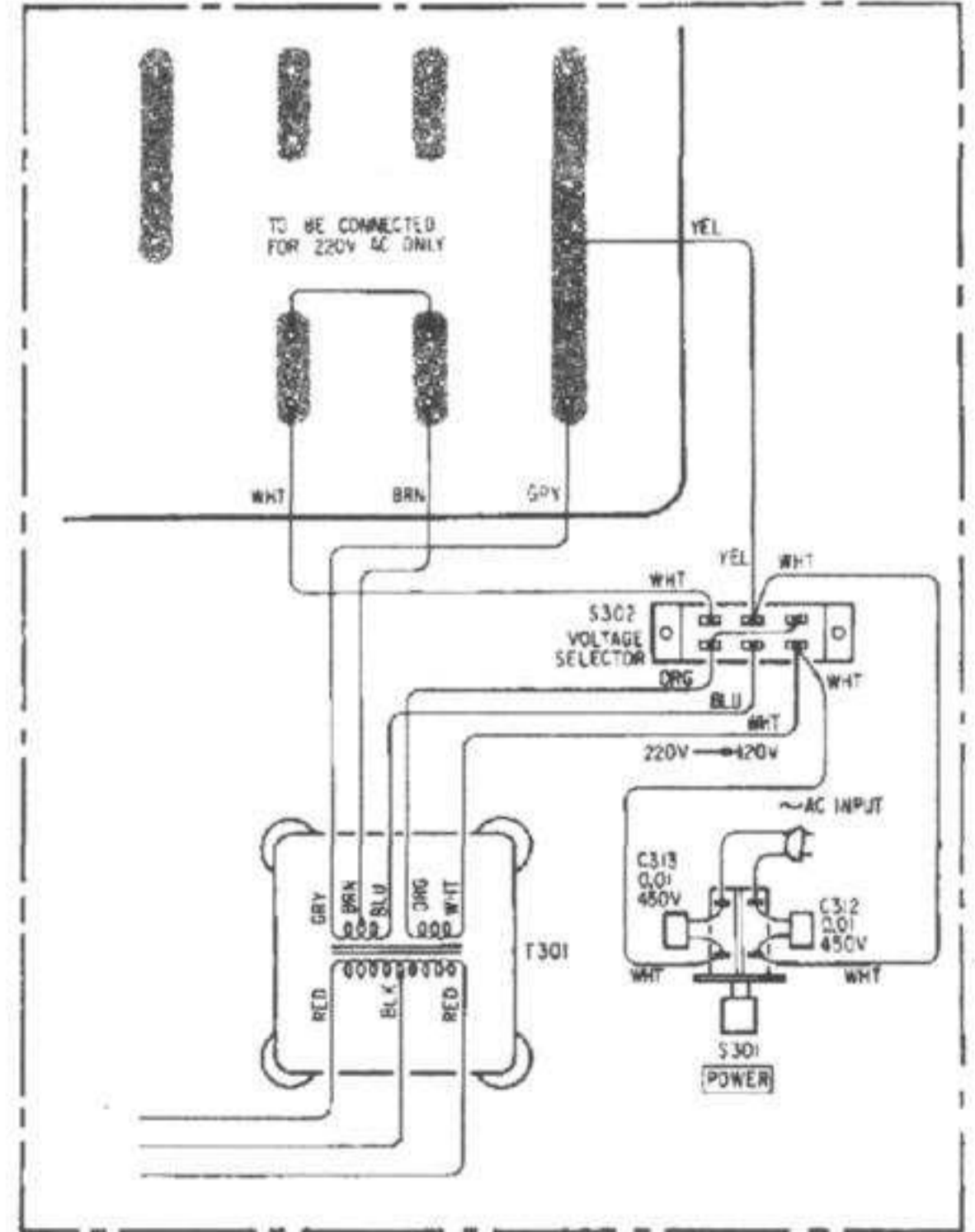

702	701	705	707		Q
		703			
		701		307	D