

STEREO TURNTABLE

# PL-1120

OPERATING INSTRUCTIONS

HGT



 PIONEER

The PL-112D is a high precision belt drive turntable designed for incorporation into a component type stereo music system.

It is recommended that you read these Operating Instructions completely before using the turntable.

The PL-112D is prelubricated at the factory, but the oil may have dried up during shipment, so before use apply a few drops of the accessory oil as described on page 10.

## CONTENTS

PL-112D Features .....	2
Attaching the Cartridge .....	3
Assembly Steps .....	4
Component Locations .....	5
Tonearm Adjustments .....	6
Stereo Amplifier Connections .....	7
Dust Cover .....	7
Panel Facilities .....	8
Operation .....	9
Care of Your Turntable .....	10
Conditions Frequently Mistaken for Malfunction .....	11
Specifications .....	12

## PL-112D FEATURES

### Precision Belt Drive with 4-pole Synchronous Motor

Stable rotation of the 30cm diecast aluminum alloy platter is maintained by the carefully engineered 4-pole synchronous motor and belt drive system. The smooth running of the motor is unaffected by fluctuations in line voltage and load, while even the slightest vibrations from the motor are absorbed by the polyurethane belt. High performance is exemplified by the 0.07% (WRMS) wow and flutter, and 63dB (DIN-B) signal to noise ratio.

### High Sensitivity S-shaped Tonearm

The tonearm gimbal incorporates high precision angular contact bearings, whose low vibration and friction ensure high sensitivity together with long term reliability. Anti-skating and lateral balance controls are included for optimum performance with high compliance cartridges and light tracking forces, and the direct readout of the tracking force is especially convenient when replacing the cartridge.

### Numerous Additional Features

A host of additional features enhance the convenience and performance of the PL-112D. Among these are a lightweight, high rigidity aluminum headshell, low capacitance output cord, free-stop dust cover hinges that allow easy installation and removal, and an oil-damped tonearm elevation mechanism to protect valuable records and stylus. The interior of the cabinet is lined with aluminum foil to screen out external electrical noise which is often picked up from other household appliances, while motor and external vibrations are also isolated by the vibration-absorbing spring suspension design.

### Sophisticated Cabinet Styling

The baseplate is made from mineral solid, a new high density material which combines excellent acoustic absorption properties to prevent resonance with high strength and attractive finish. In addition the elegant wood grain finish of the cabinet ideally matches the high quality engineering of the PL-112D.

# ATTACHING THE CARTRIDGE

Moving magnet (MM), moving coil (MC) and induced magnet (IM) are the main cartridge types. Although all of these can be used with the PL-112D, select cartridges with weights between 4 ~ 10 grams. Refer to the cartridge operating instructions for connection and handling. Since the tonearm of the PL-112D is a universal type, your optional cartridge with standard type headshell can be attached with no problem. Install the cartridge in the headshell according to the following steps.

1. When attaching the cartridge to the accessory headshell, use the headshell, screwdriver, overhang gauge, screws, nuts and washers supplied in the accessory box (Fig. 4).
2. Connect headshell lead wires to the cartridge. Observe lead wire color coding as follows.
 

White	L	(left channel)
Blue	LG	(left channel ground)
Red	R	(right channel)
Green	RG	(right channel ground)
3. Fit cartridge to headshell (Fig. 1), but do not tighten the mounting screws.
4. Set the headshell into the accessory overhang gauge as shown in Fig. 2. Adjust the cartridge position so that the stylus tip is aligned with the gauge line. Finally, tighten the cartridge mounting screws.
5. Install headshell on tonearm according to Fig. 8 on the following page.
 

If your cartridge weighs over 7.0g, insert the sub weight into the end of the tonearm shaft. Refer to Fig. 3.

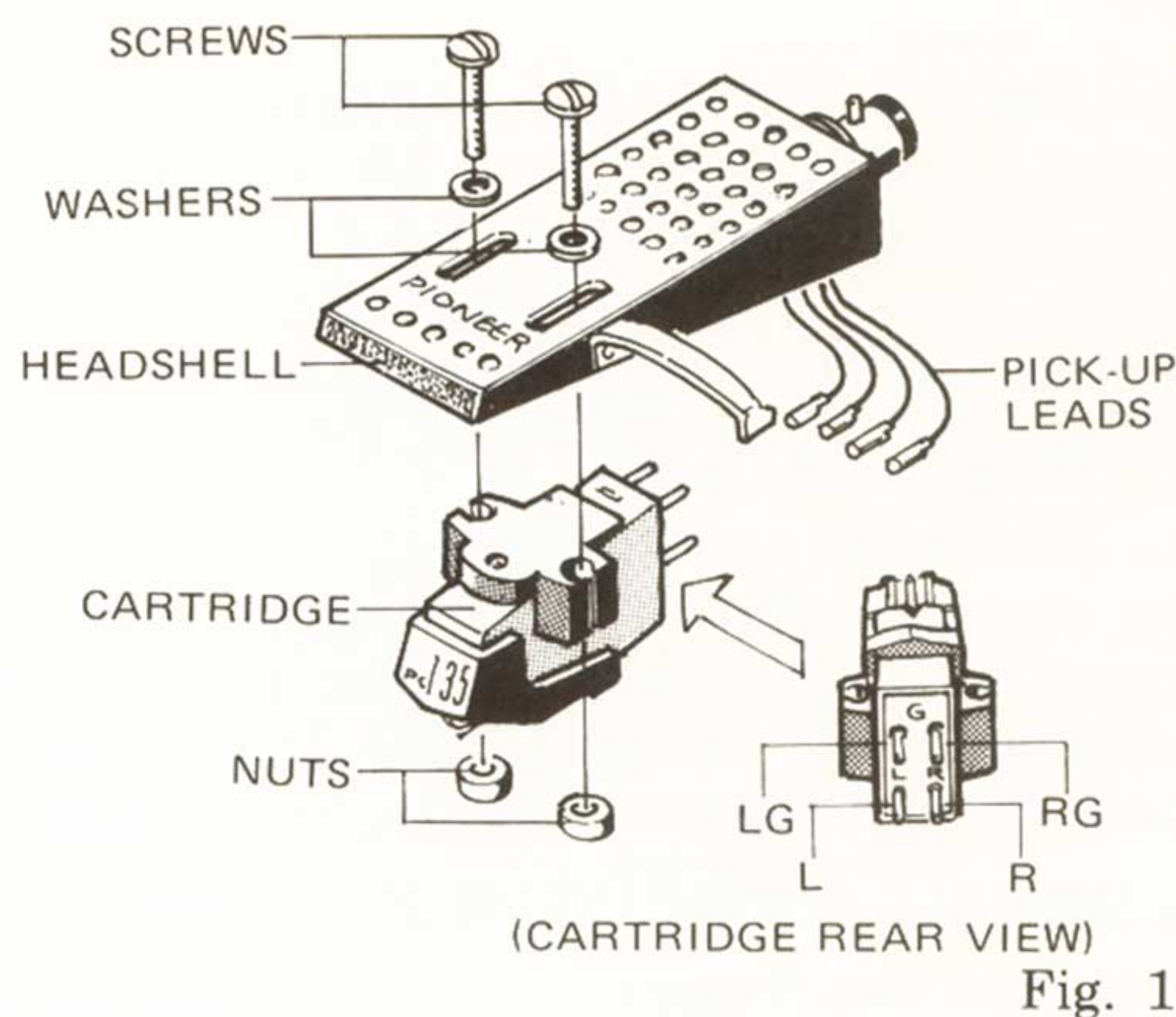

Fig. 1

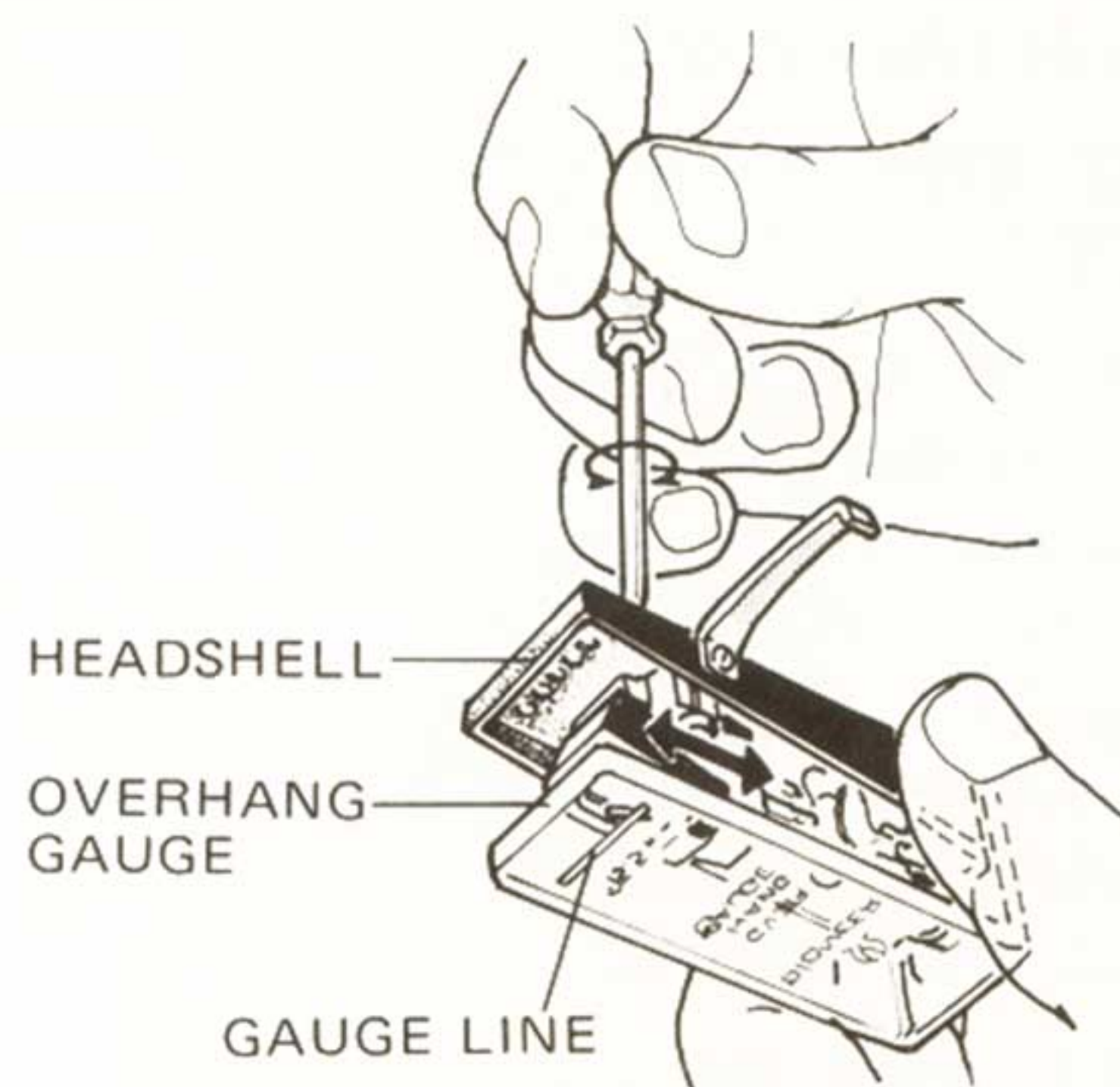

Fig. 2

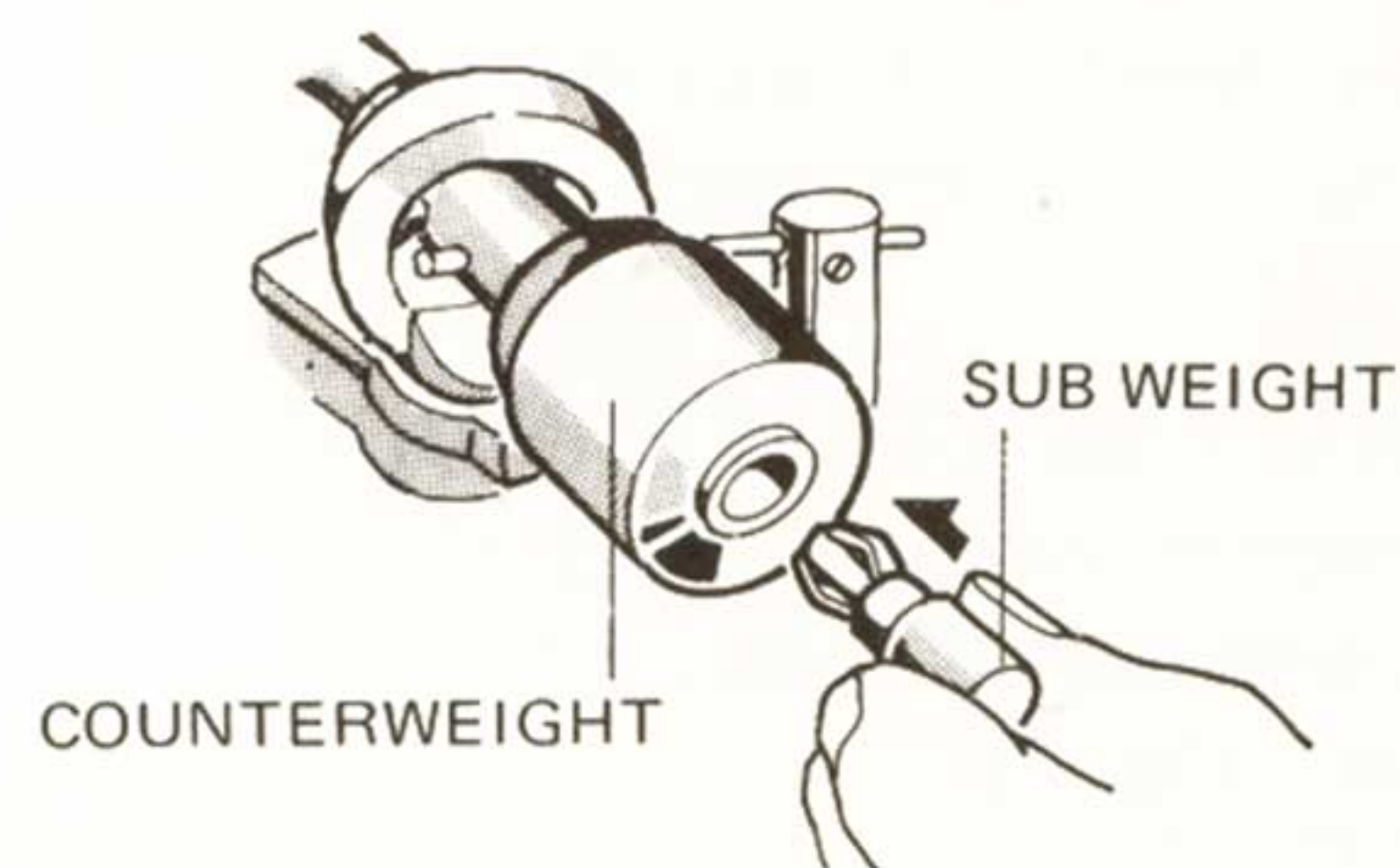

Fig. 3

## ACCESSORIES

The accessory box contains the following parts.

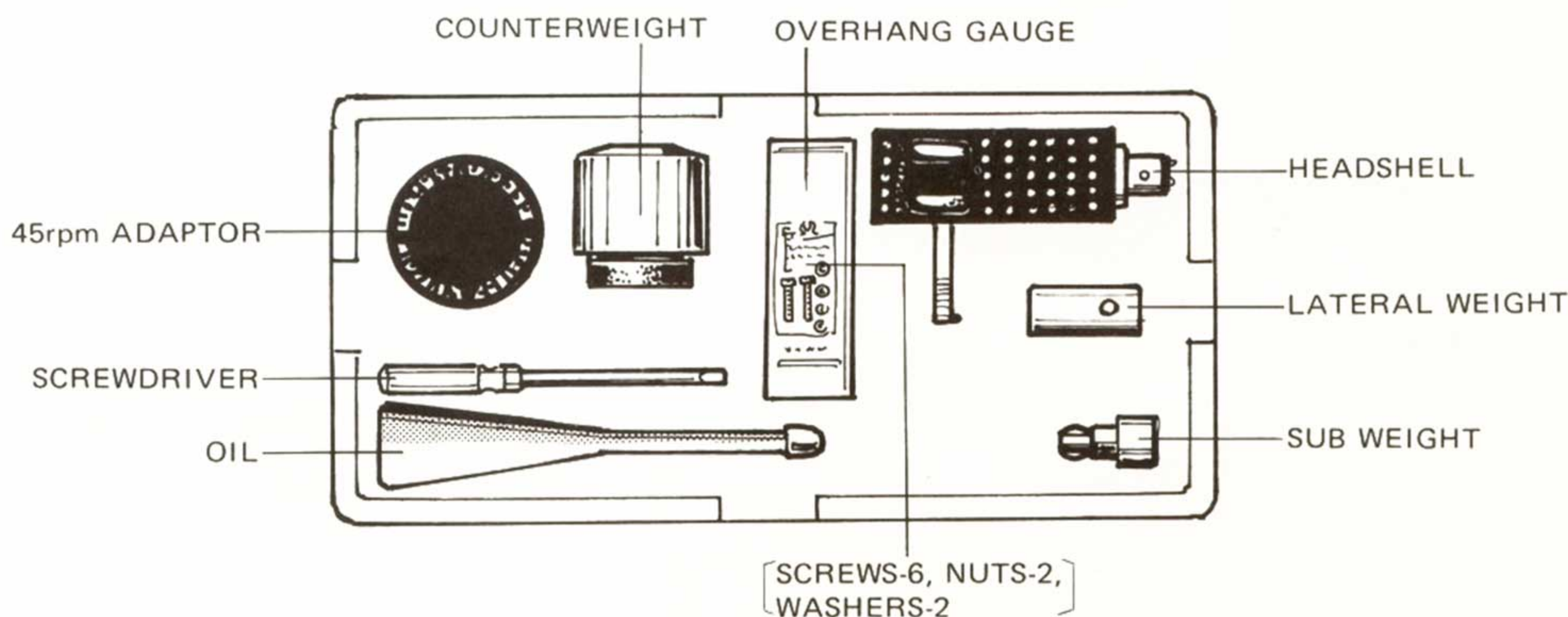

Fig. 4

# ASSEMBLY STEPS

## 1. REMOVE TONEARM PACKING

The tonearm is protected by styrofoam cushioning material during shipment. Peel off the tape and taking care not to exert unnecessary force on the tonearm, remove the packing material (Fig. 5).

## 2. TAKE OUT CLAMP SCREW

As protection against possible damage in transit, the chassis is secured to the base plate with the 5 screws (Fig. 6). These must be removed before assembling the turntable. The chassis will then float on its vibration-absorbing spring suspension.

## 3. INSTALL TURNTABLE PLATTER

Using the two finger holes (Fig. 19) lift the platter and carefully place it onto the center shaft (Fig. 11).

## 4. MOUNT THE BELT ON THE MOTOR PULLEY

Set the speed select lever to the 33 position. Pulling the ribbon attached to the drive belt, pass the belt through the belt guide and around the smaller diameter (the upper portion) of the motor pulley (Fig. 7).

After the belt has been properly positioned on the motor pulley, remove the ribbon and put on the rubber mat and decorative ring (Fig. 11).

## 5. INSTALL THE HEADSHELL

Insert the headshell into the tonearm sleeve and lock it in place by turning the locking collar. (Fig. 8)

## 6. MOUNT THE COUNTERWEIGHT

Fit the counterweight onto the rear end of the tonearm and turn it 2 or 3 times in the direction of the arrow (Fig. 9).

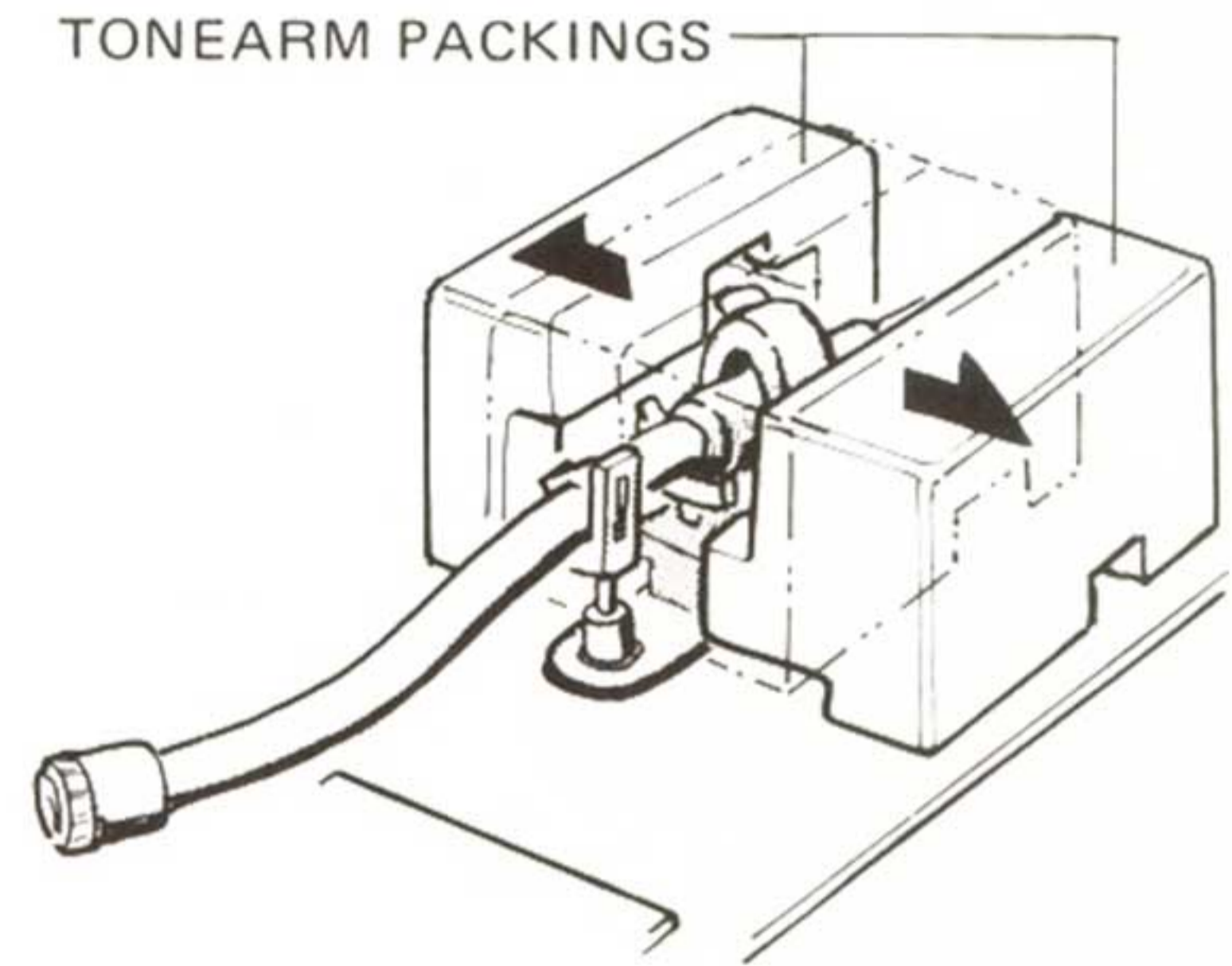

Fig. 5

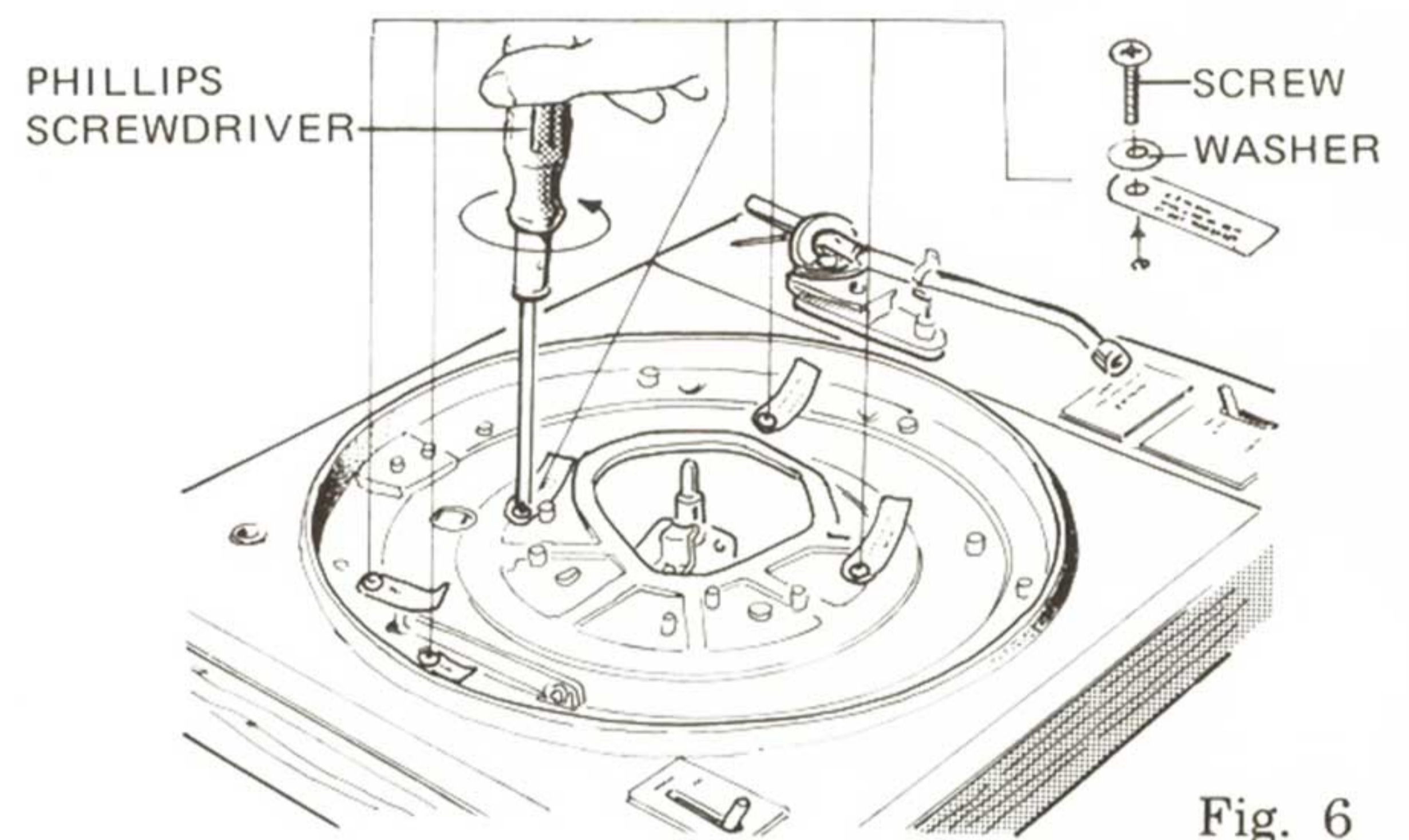

Fig. 6

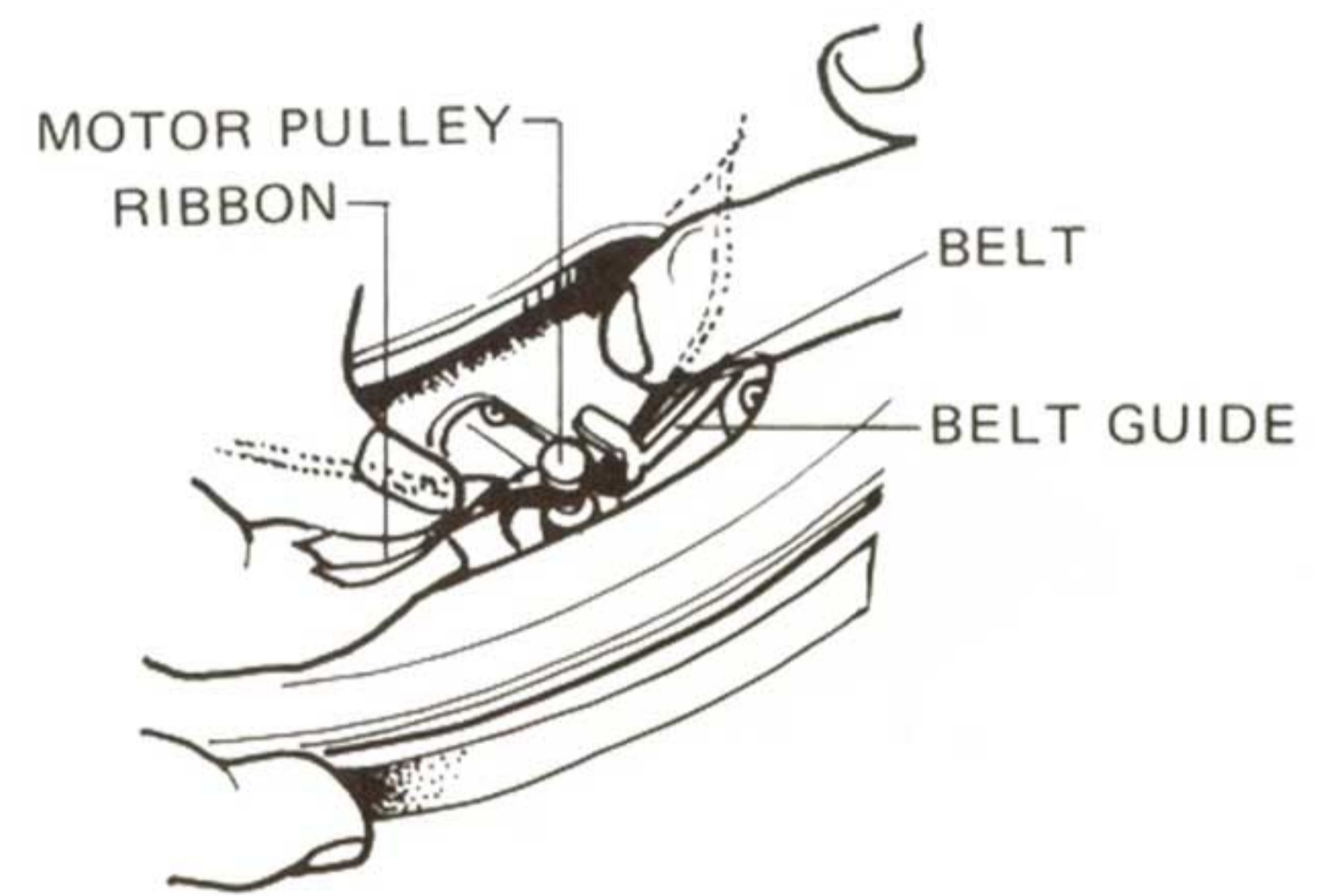

Fig. 7

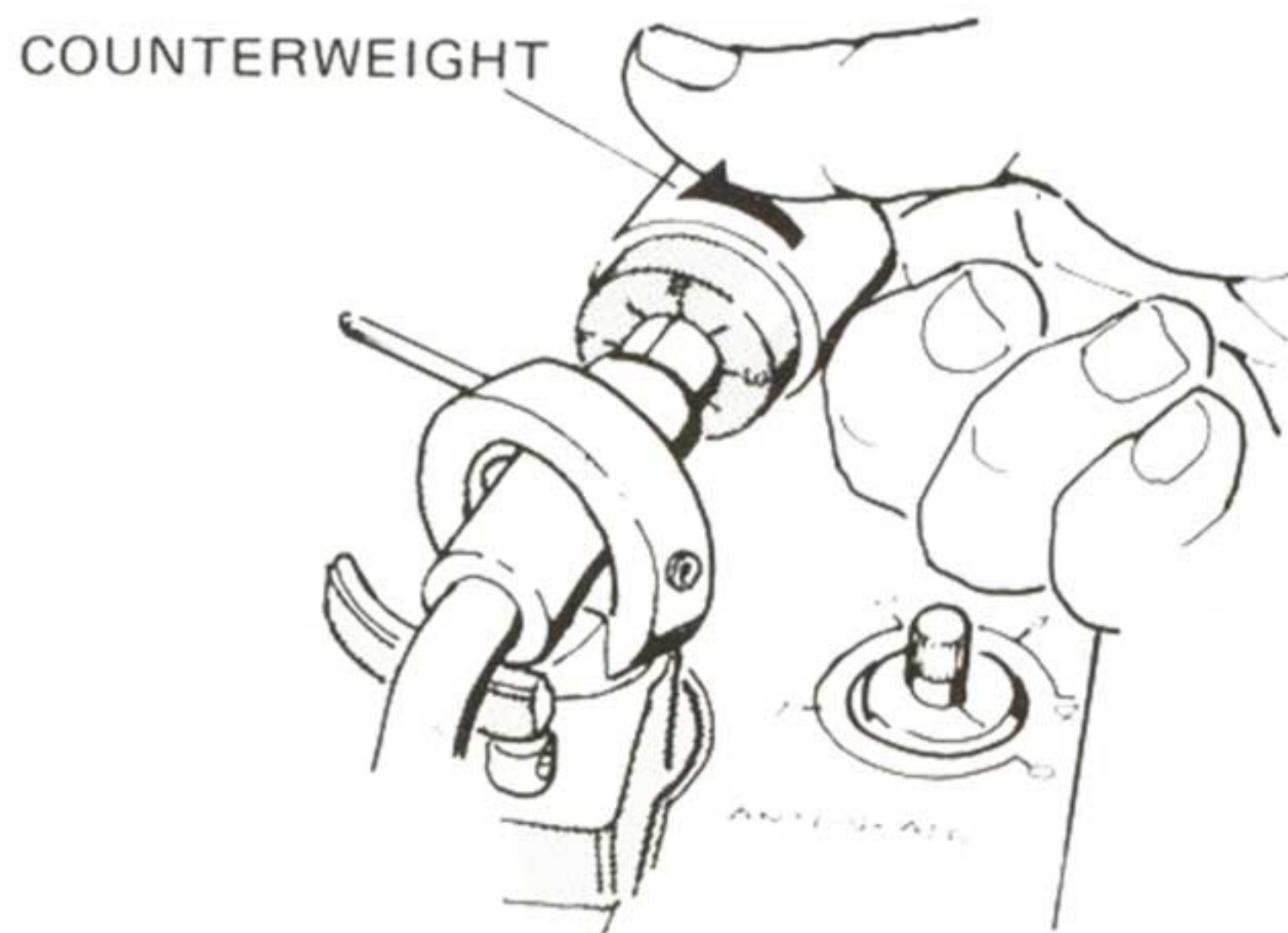

Fig. 9

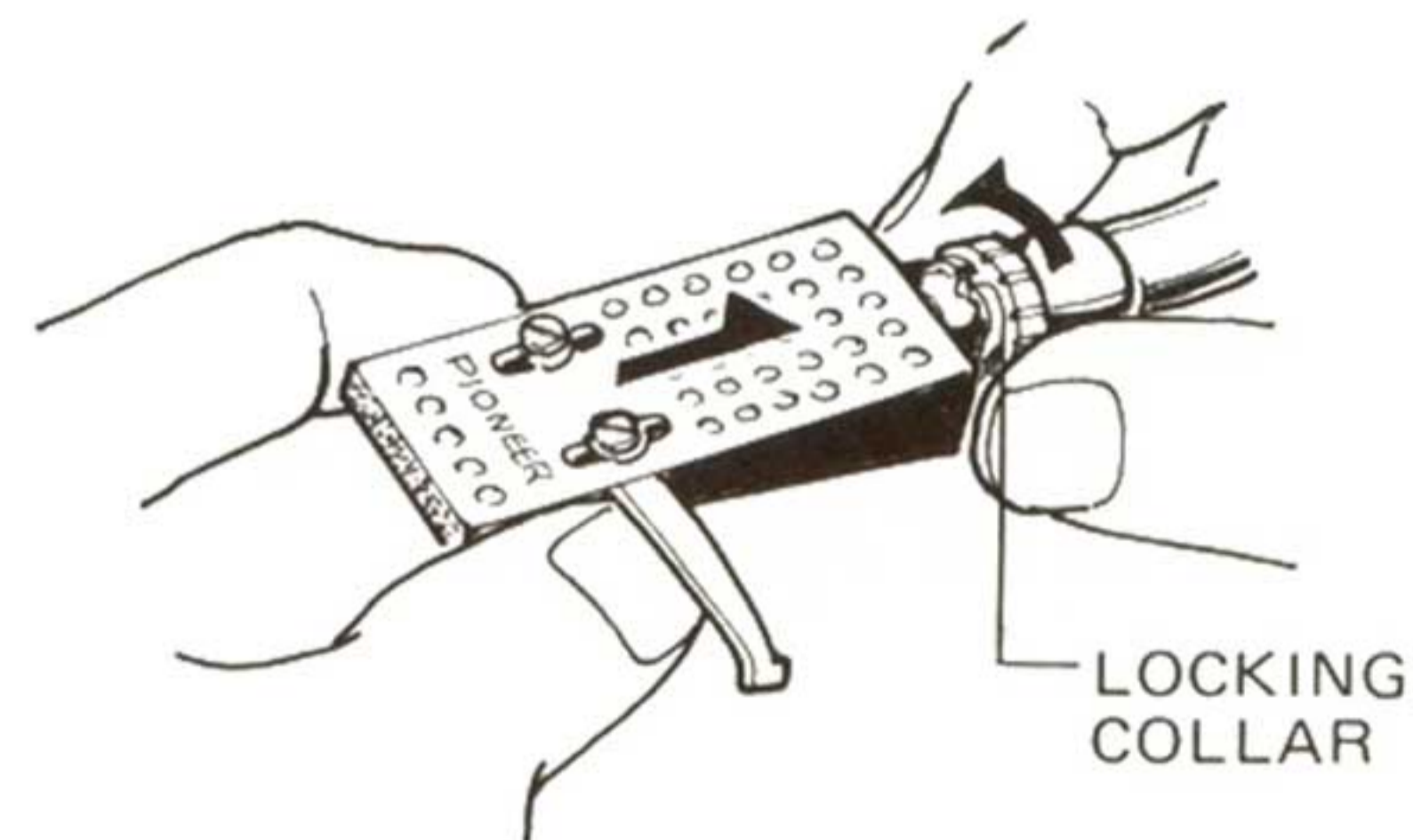

Fig. 8

### 7. ATTACH LATERAL WEIGHT

Use the accessory screwdriver to fix the lateral weight on its bar and adjust for 18–23mm spacing between the lateral weight and tonearm (Fig. 10). Readjustment is not required, even when replacing the cartridge.

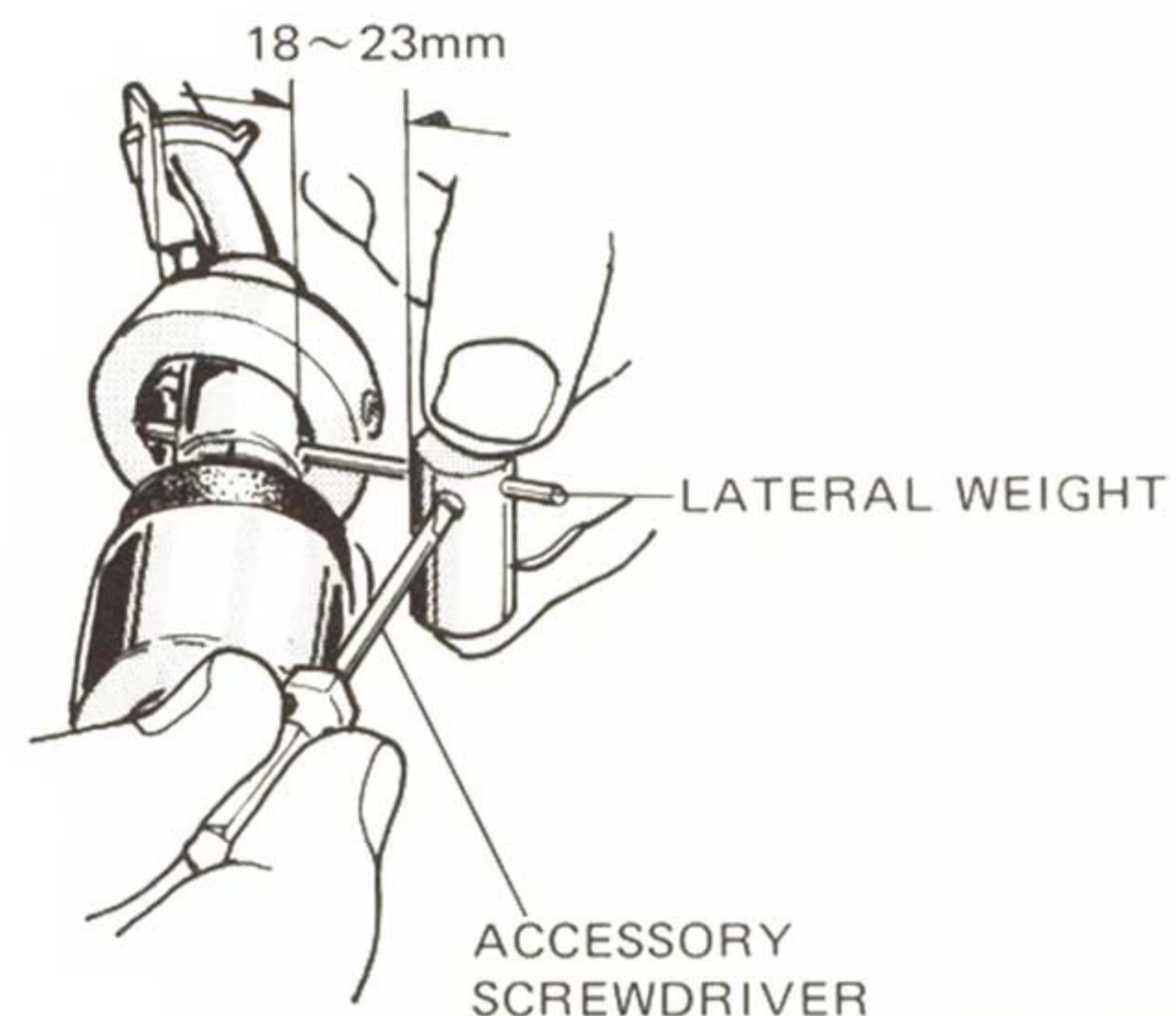

Fig. 10

## COMPONENT LOCATIONS

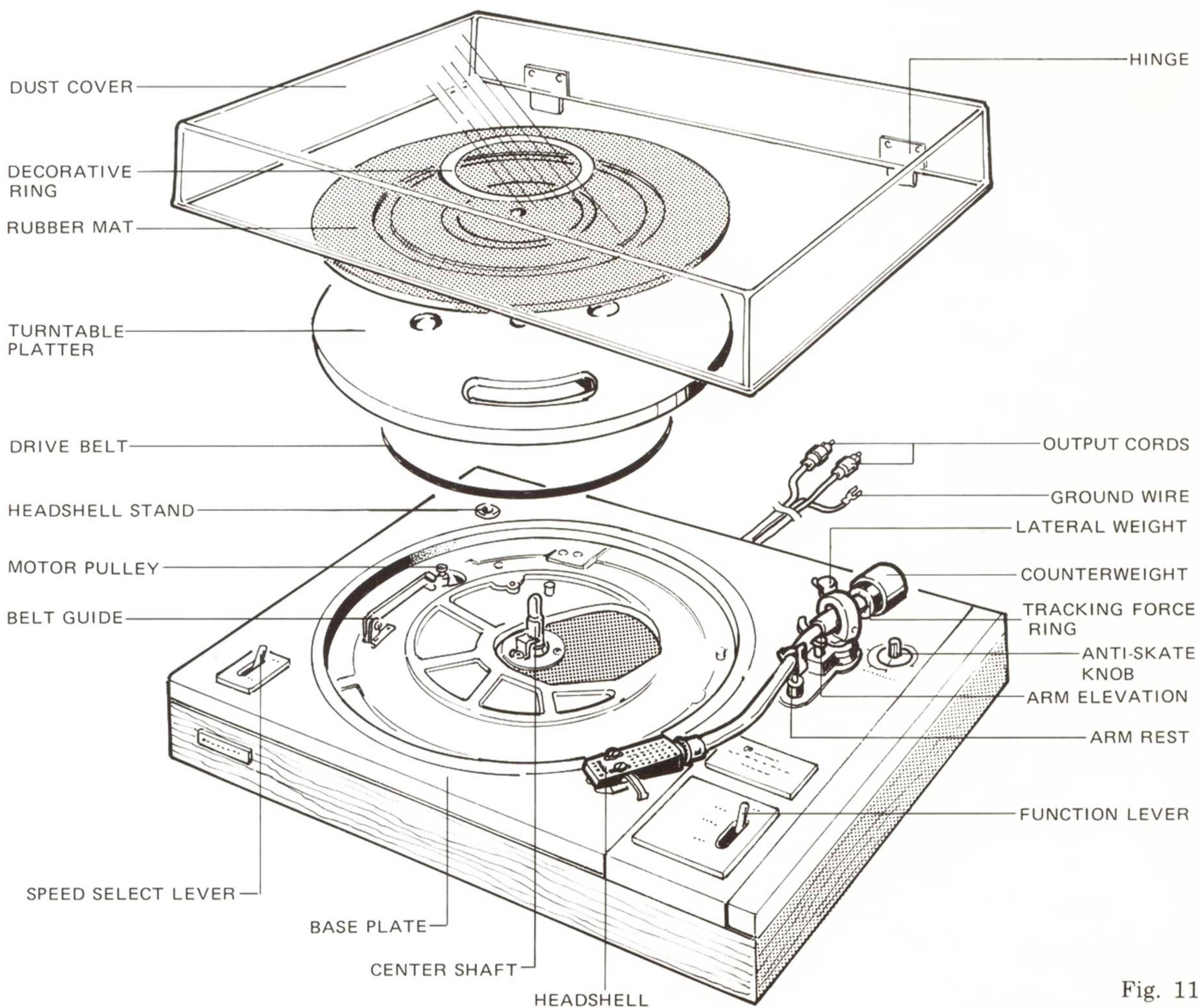
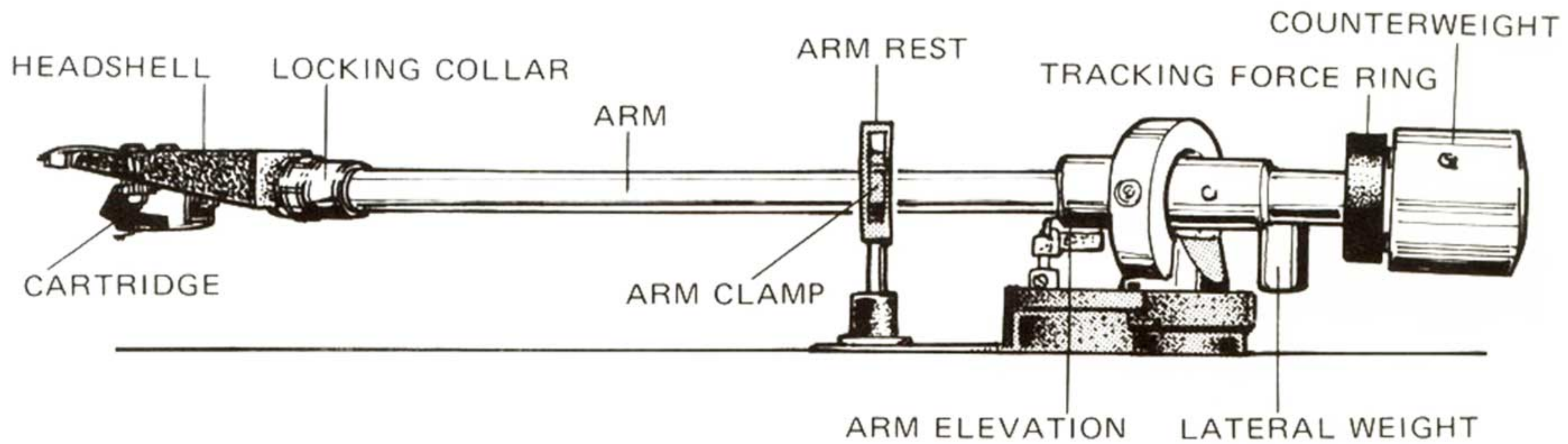

Fig. 11

# ONEARM ADJUSTMENTS



Tonearm Parts

Fig. 12

After correctly assembling the tonearm, perform the following adjustments. Do not connect the AC cord to the mains outlet until adjustments have been completed.

## HORIZONTAL BALANCE

1. Set ANTI-SKATE knob to 0 (Fig. 14).
2. Uncover the stylus.
3. Set function lever to DOWN.
4. Release the arm clamp and disengage the tonearm from the arm rest. Since the tonearm moves freely at this time, take care not to damage the stylus.
5. Turn the counterweight and adjust so that the tonearm becomes level with the platter, without slanting either toward the headshell or counterweight. Figs. 13-A and 13-B show the tonearm in unbalanced conditions.

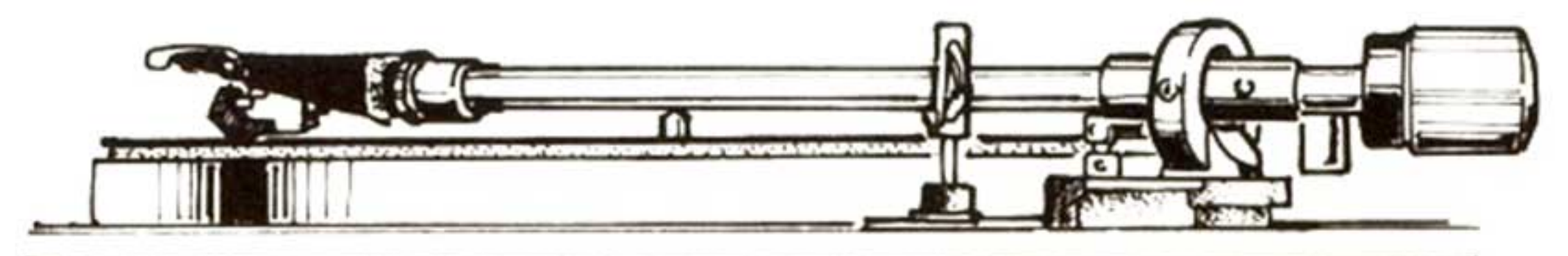

Correctly Balanced

Fig. 13

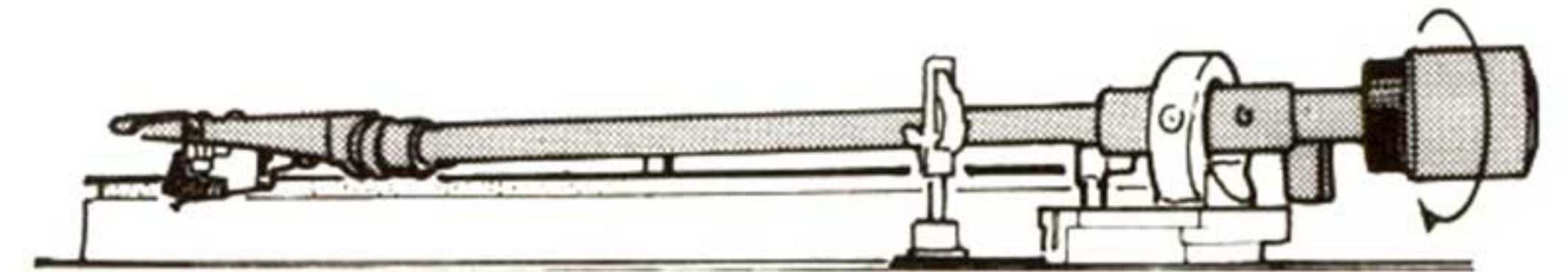

Fig. 13-A: Headshell end heavy – turn counterweight in direction of arrow.

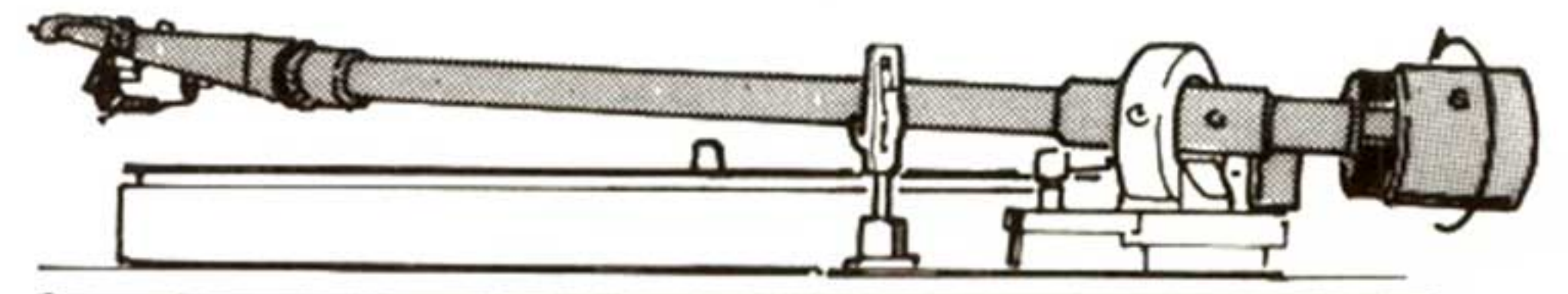

Fig. 13-B: Counterweight end heavy – turn in direction of arrow.

**NOTE:**

If the cartridge is too heavy to adjust by this means, attach the sub weight according to Fig. 3 on page 3.

6. Return the tonearm to the arm rest and engage the clamp.
7. Since the tonearm is balanced, the tracking force is zero, so turn the tracking force ring at the front of the counterweight (taking care not to disturb the counterweight) to align the 0 with the reference line (Fig. 14).

## TRACKING FORCE

Turn the counterweight and align the indication on the tracking force ring which corresponds to the recommended tracking force of the employed cartridge with the reference line (Fig. 15). The ring is divided into 0.5 gram divisions and 1 rotation is equivalent to 4 grams tracking force.

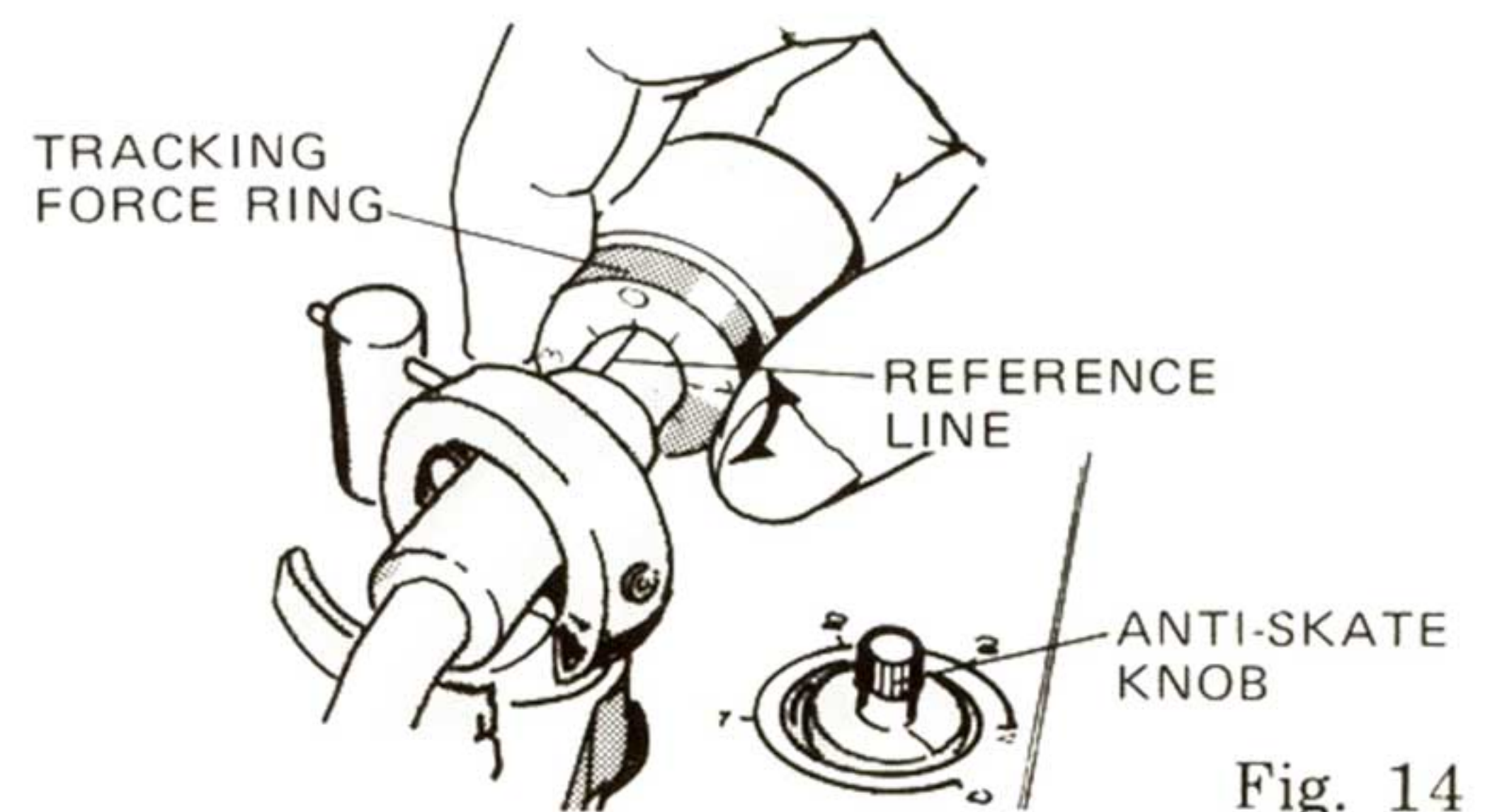

Fig. 14

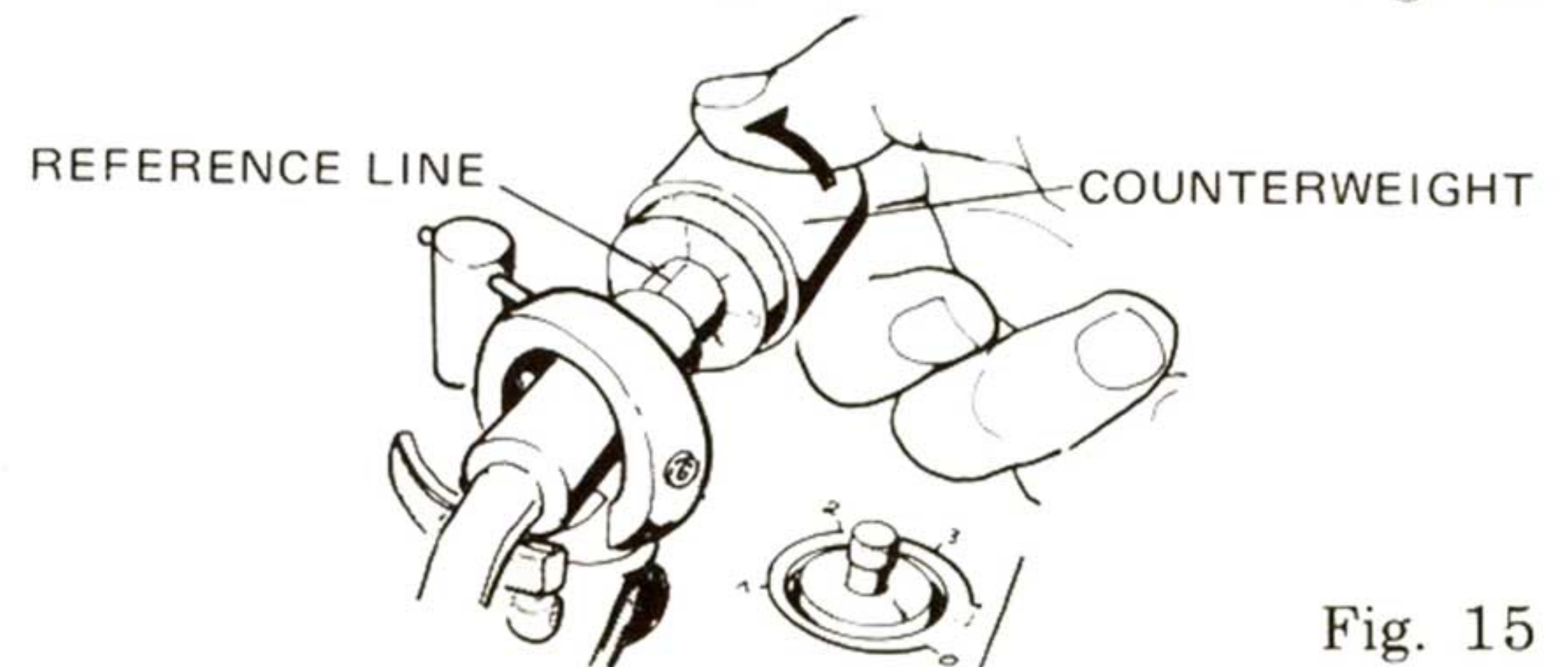

Fig. 15

### ANTI-SKATING

Set the ANTI-SKATE knob to the same value as the tracking force of the employed cartridge. For example, if the tracking force is 2 grams, set this knob to 2 (Fig. 16).

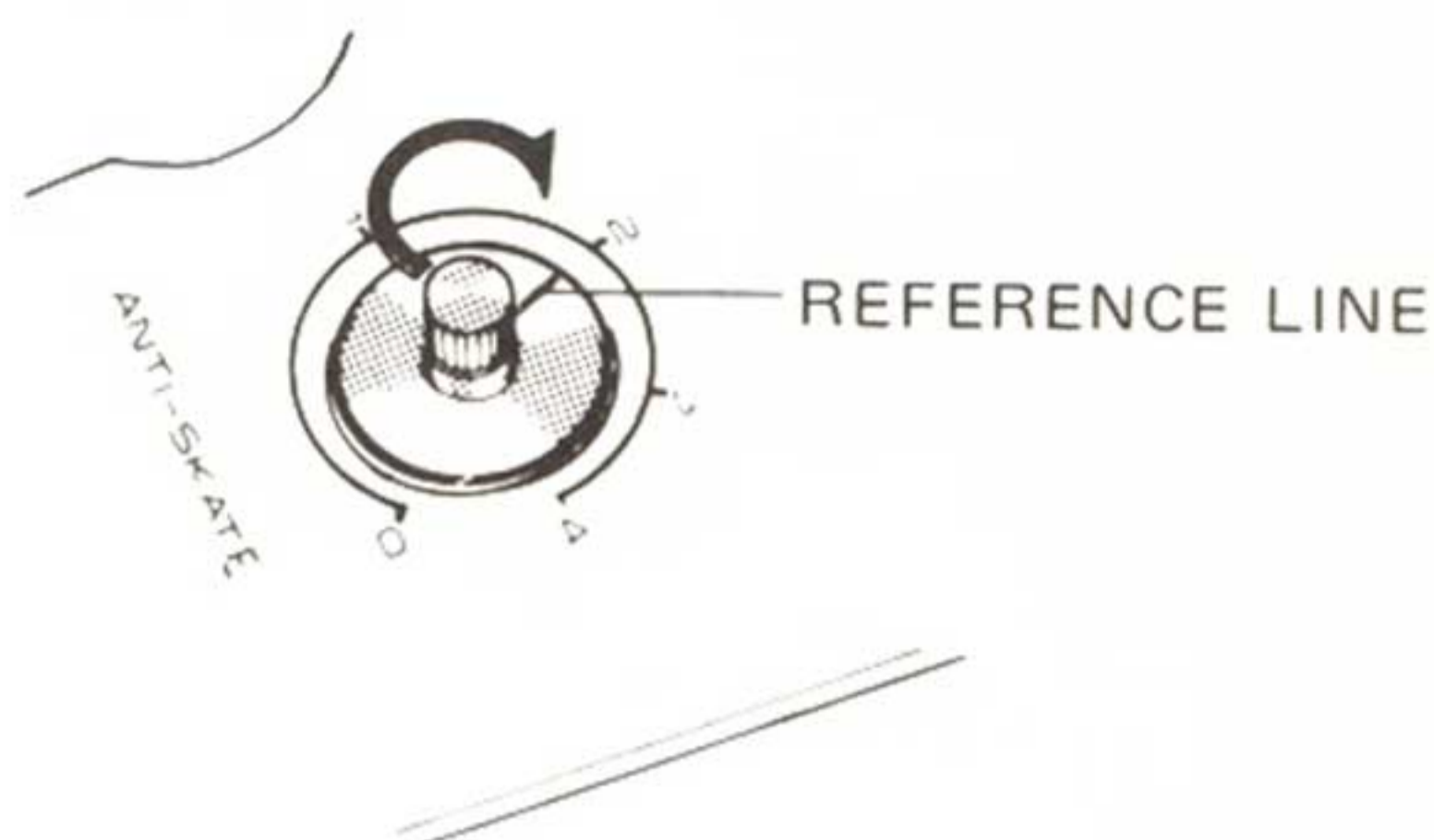

Fig. 16

## STEREO AMPLIFIER CONNECTIONS

The phono inputs of the amplifier to which the turntable should be connected must be chosen in accordance with type of phono cartridge to be used.

- With moving magnet or induced magnet type cartridge:  
Connect to the PHONO MAG inputs of the amplifier.
- With low-output moving coil type cartridge:  
Connect to the PHONO MC inputs. If these are not provided on your amplifier, a step-up transformer will be required.

**NOTE:**

Refer to the cartridge instruction manual for further details.

In either case, connect the red output plug from the turntable to the amplifier's right channel input and the white plug to the left channel input. The third black wire (the ground wire) with the split lug can be connected to the GROUND terminal of your amplifier (Fig. 17). Do not forget to make this connection, because it is vital for avoiding hum and noise.

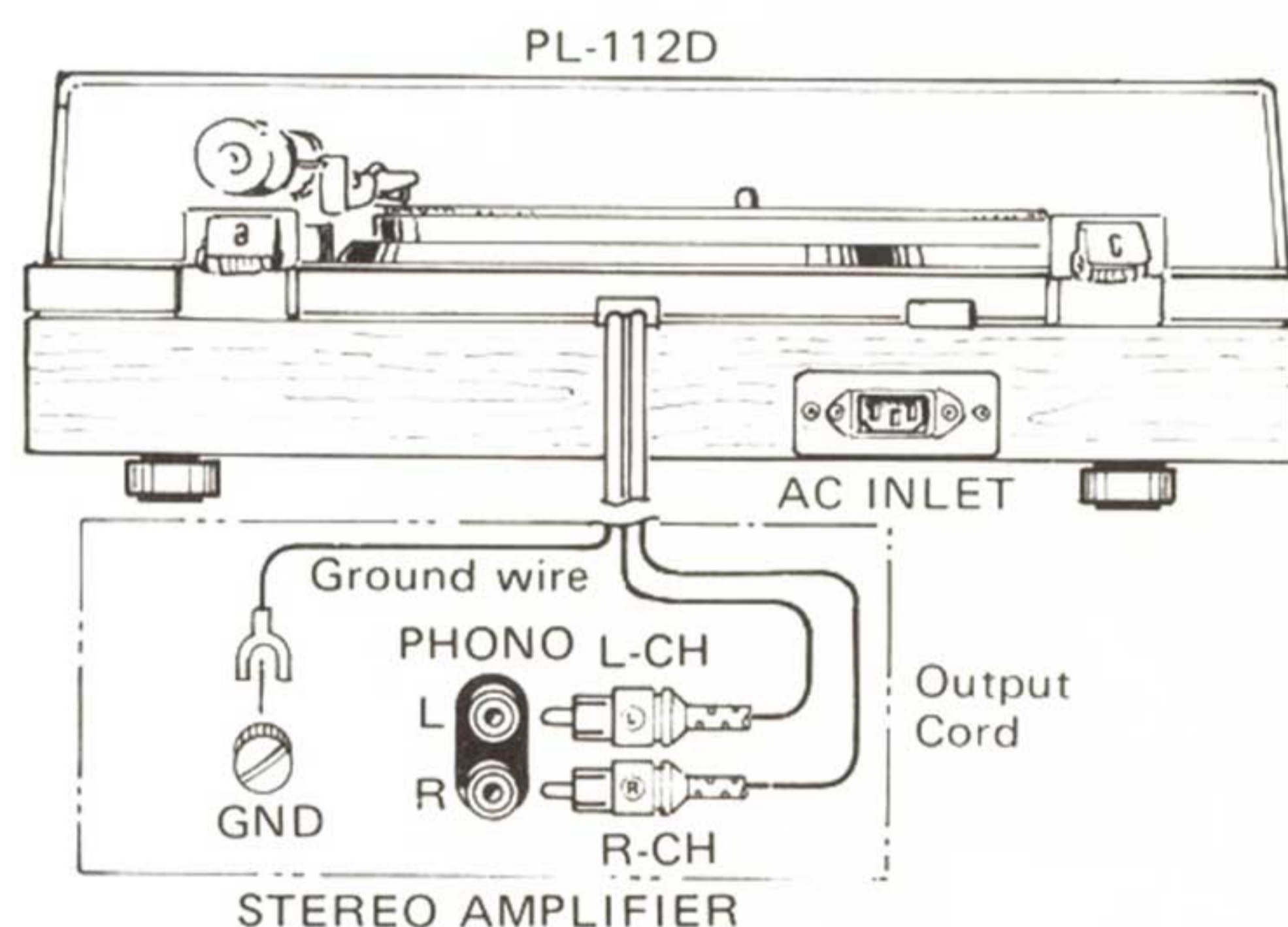

Fig. 17

### DUST COVER

It is convenient to install the dust cover from the rear of the turntable as shown in Fig. 18. Hold the cover at the bottom and insert its hinges into the sockets of the turntable base. To remove the dust cover, again grasp it as shown in Fig. 18 and pull it straight upward.

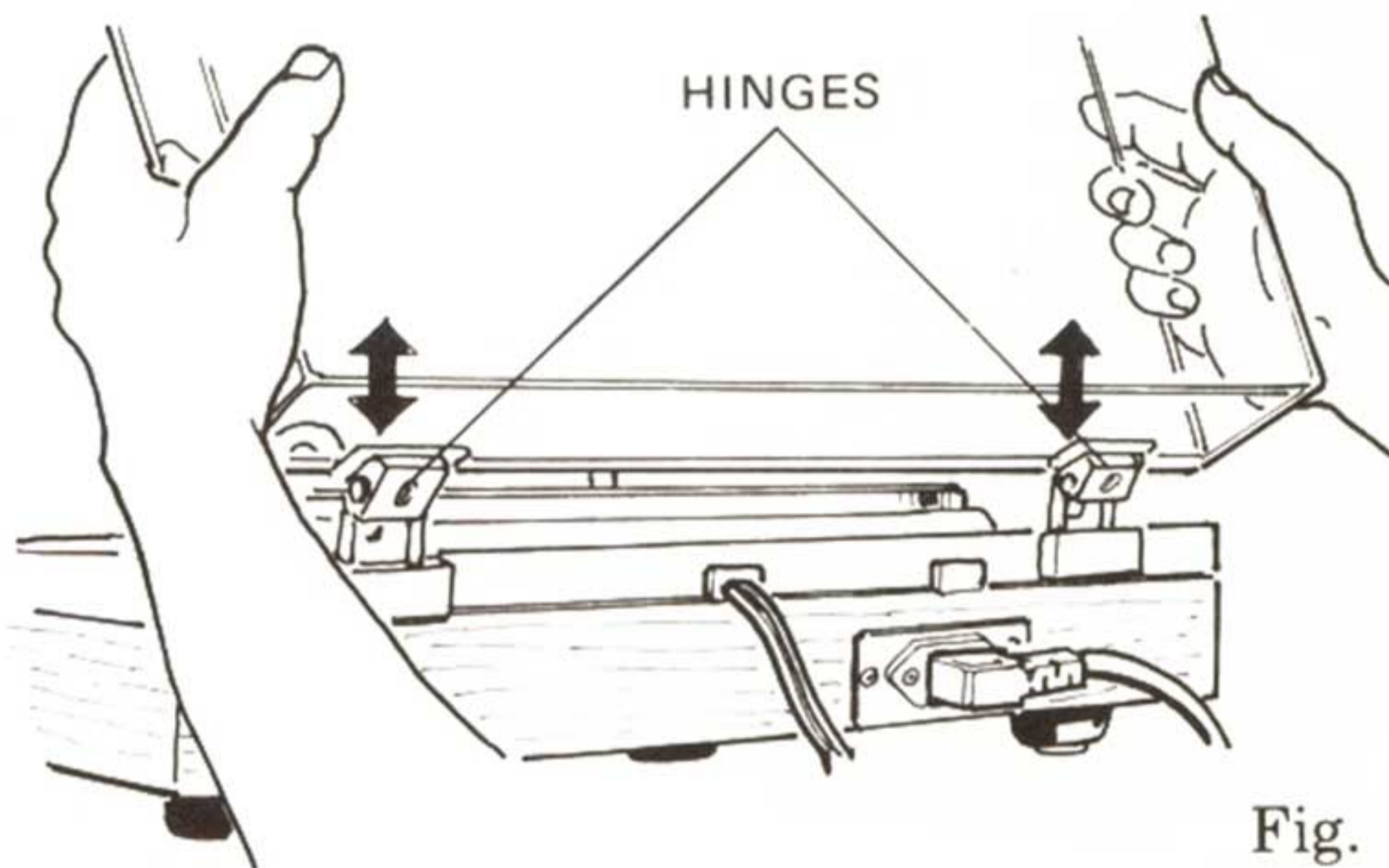

Fig. 18

### INSTALLATION HINTS

Pay attention to the following points when selecting a location for the PL-112D.

- The place must be well-ventilated and free from humidity and dust.
- Avoid exposure to direct sunlight or other sources of heat.
- Select a surface that is firm and level.
- The turntable should be placed as far from the speaker system as possible, and not too close to the power transformer of the amplifier.

# PANEL FACILITIES

## HEADSHELL STAND

A spare headshell can be stored in this stand. Align the headshell pin with the stand groove and insert. Observe that the headshell length is not greater than the height of the dust cover. This stand can also be used for storing the 45rpm adaptor.

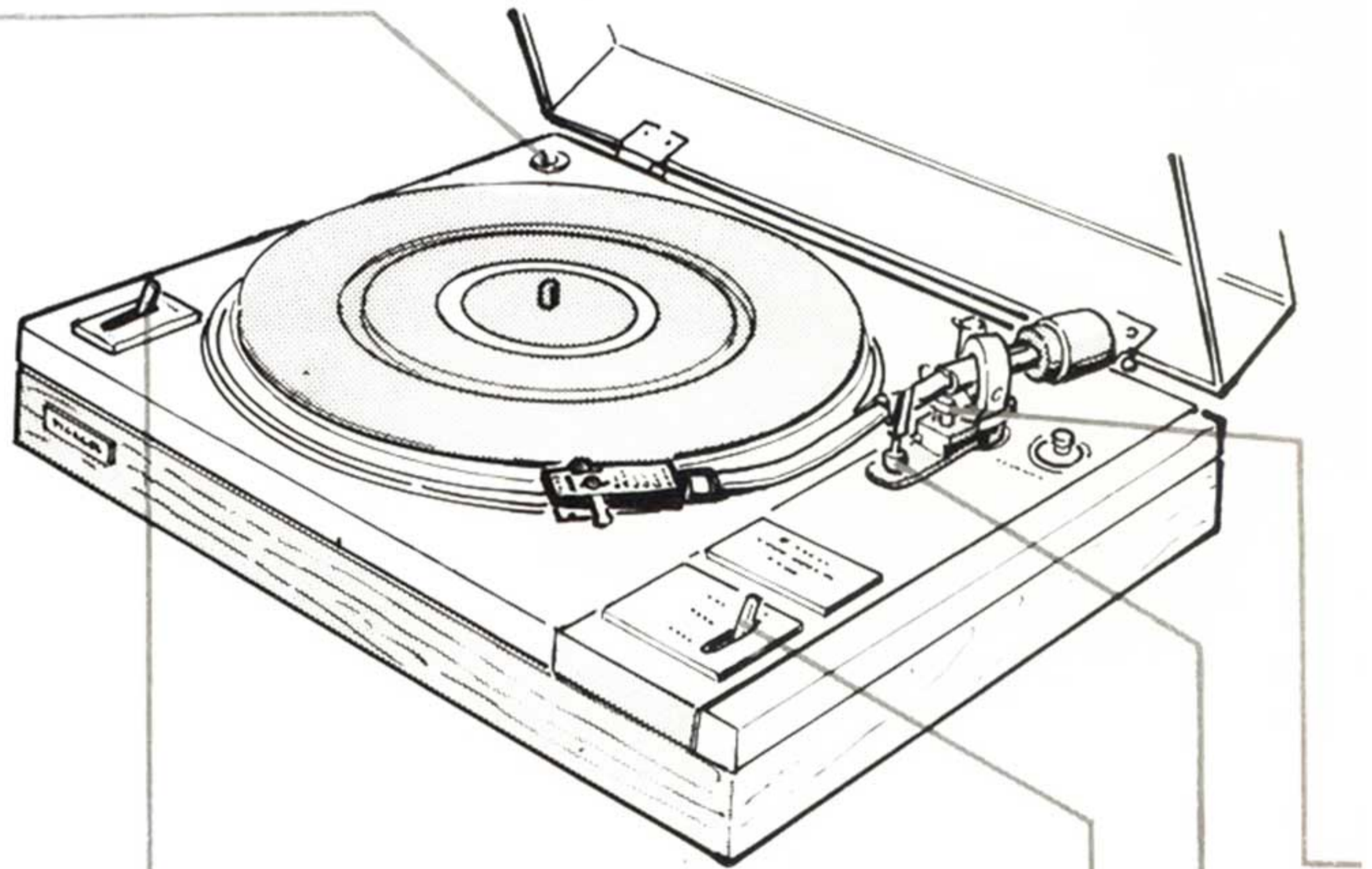
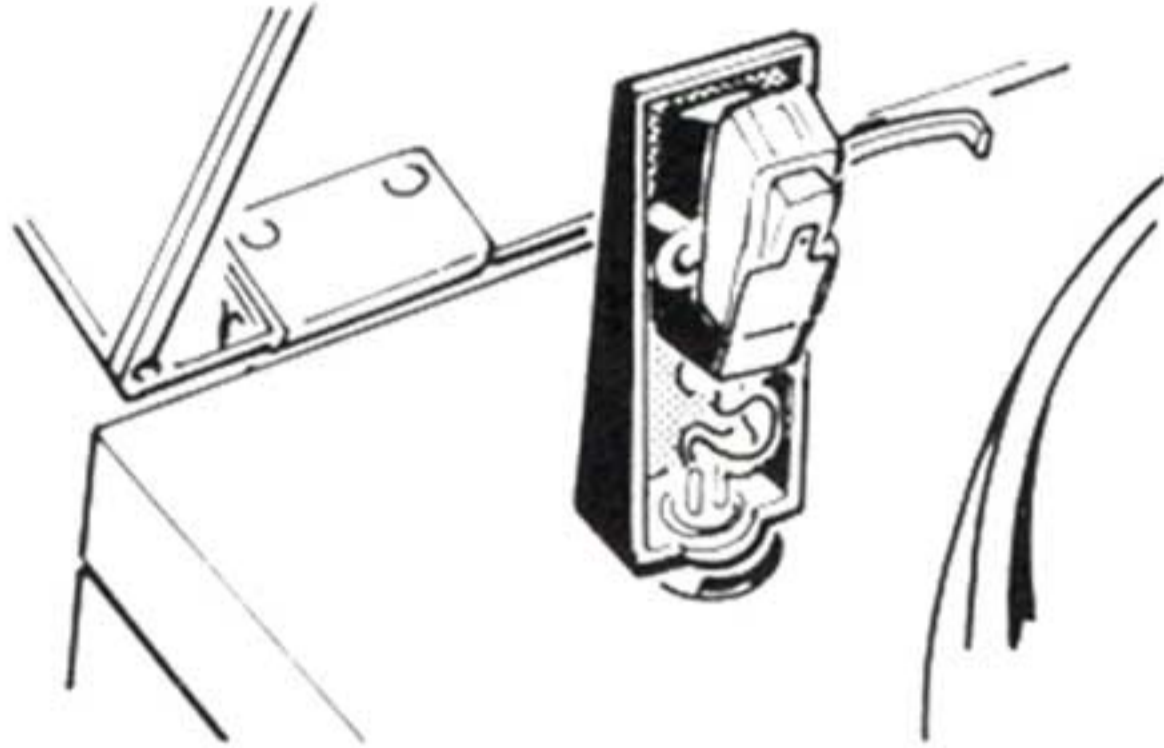

## SPEED SELECT LEVER

Either of the two speeds, 33-1/3rpm or 45rpm, can be selected by this lever. Change the lever position only while the turntable is rotating.

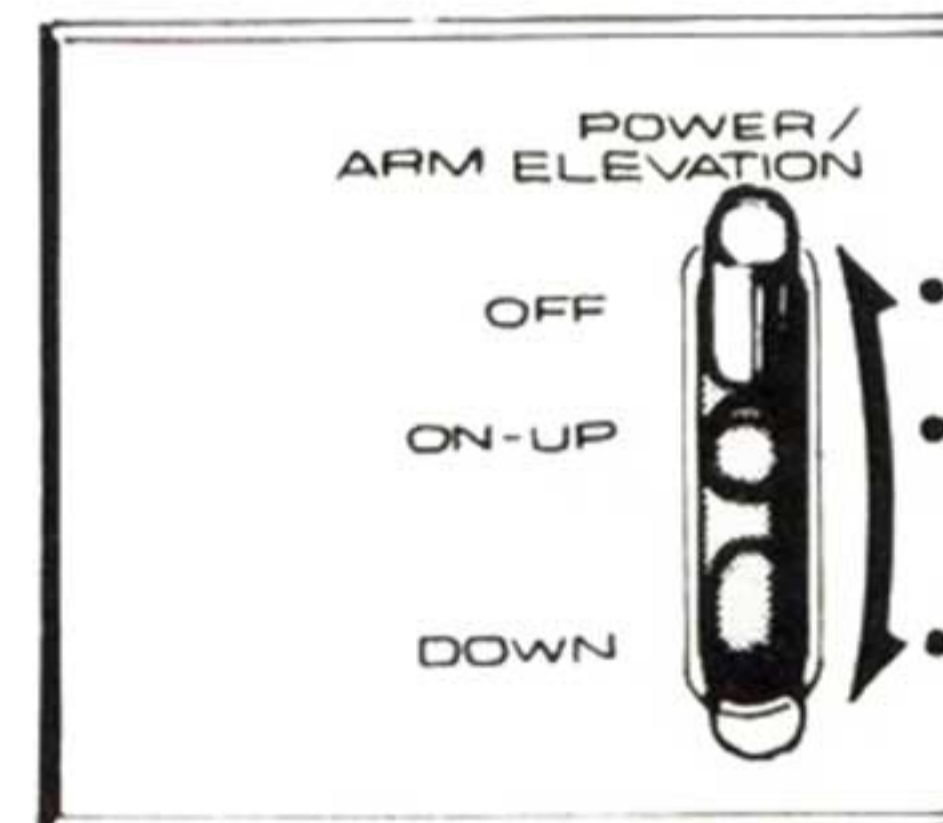
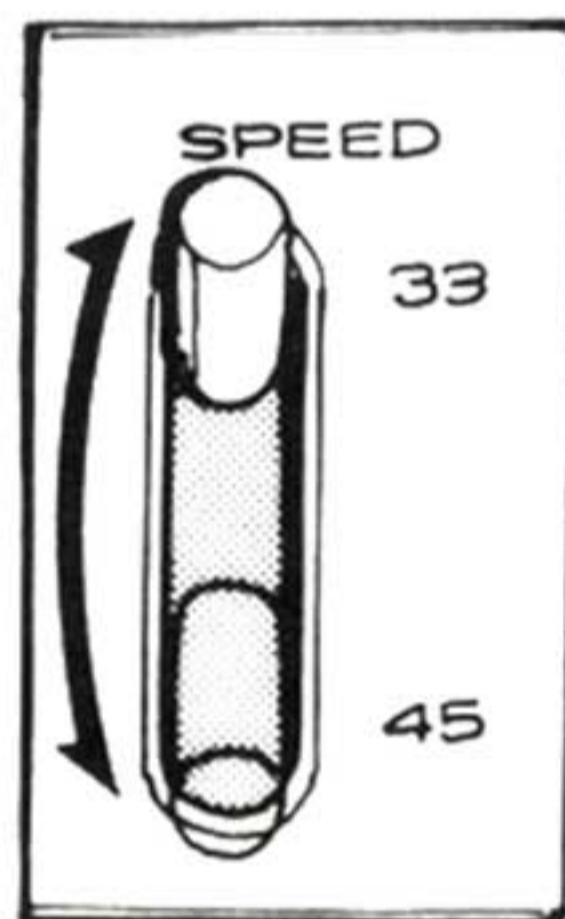

## 45 RPM ADAPTOR

A 45rpm record adaptor is supplied in the accessory box, which permits 45rpm EP records with large center holes to be played.



## FUNCTION LEVER

This lever incorporates power switch and arm elevation functions.

- OFF AC power is cut off.
- ON-UP Power is turned ON. When set from DOWN to this position, the tonearm is raised.
- DOWN Tonearm is gently lowered.



## OPERATION

1. Remove the stylus cover.
2. Set the function lever to ON-UP.  
(The turntable platter will begin to rotate.)
3. Set the SPEED select lever to the correct speed according to the record to be played.
4. Disengage arm clamp and gently position the tonearm over the desired portion of the record.
5. Set the function lever to DOWN.  
Stylus will be gently lowered onto the record.
6. Adjust the volume and tone controls of the stereo amplifier as desired.
7. At the end of the record, or to interrupt the record, set the function lever to ON-UP.
8. Return tonearm to arm rest and engage clamp.
9. Set the function lever to OFF.  
(Power will be cut off.)
10. It is advisable to replace the stylus cover for protection whenever the turntable is not in use.

### To take Full Advantage of the Function Lever (Arm Elevation)

The function lever (ARM ELEVATION) is particularly convenient when you wish to choose a particular track from an LP record.

- If you move the tonearm while the function lever is set to DOWN, take care not to damage the stylus point.

### OPERATING PRECAUTIONS

- Keep stylus and records clean. Use a stylus brush to clean the stylus and a good quality record cleaner to clean the records each time before and after playing.
- Avoid exerting unnecessary force on the tonearm. When changing headshells, set the tonearm in the arm rest and engage the clamp.
- Take care not to impart vibration to the turntable while a record is playing. Record and stylus can be damaged.
- Never touch the SPEED select lever if the turntable is stationary. The speed can be changed only while the turntable is rotating.
- Never obstruct the turntable while it is rotating. This may cause damage.
- Avoid placing more than 1 record on the turntable platter while playing record.

### —ARM ELEVATION

Arm elevation may require adjustment according to cartridge height. If necessary use the accessory screwdriver to loosen the setscrew and adjust (see figure).

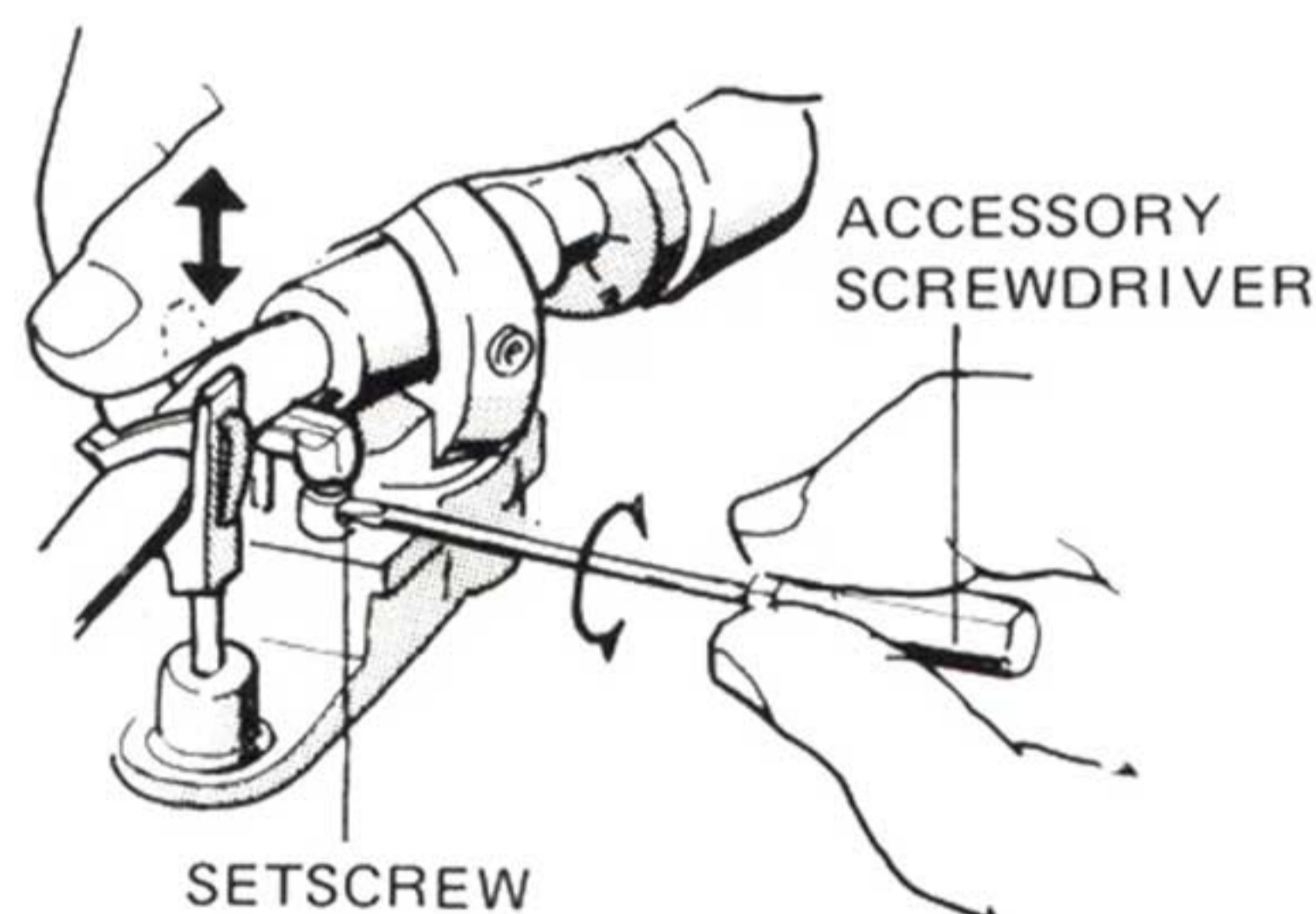

### —ARM REST

The arm rest supports the tonearm, which should be secured by the arm clamp when not in use.

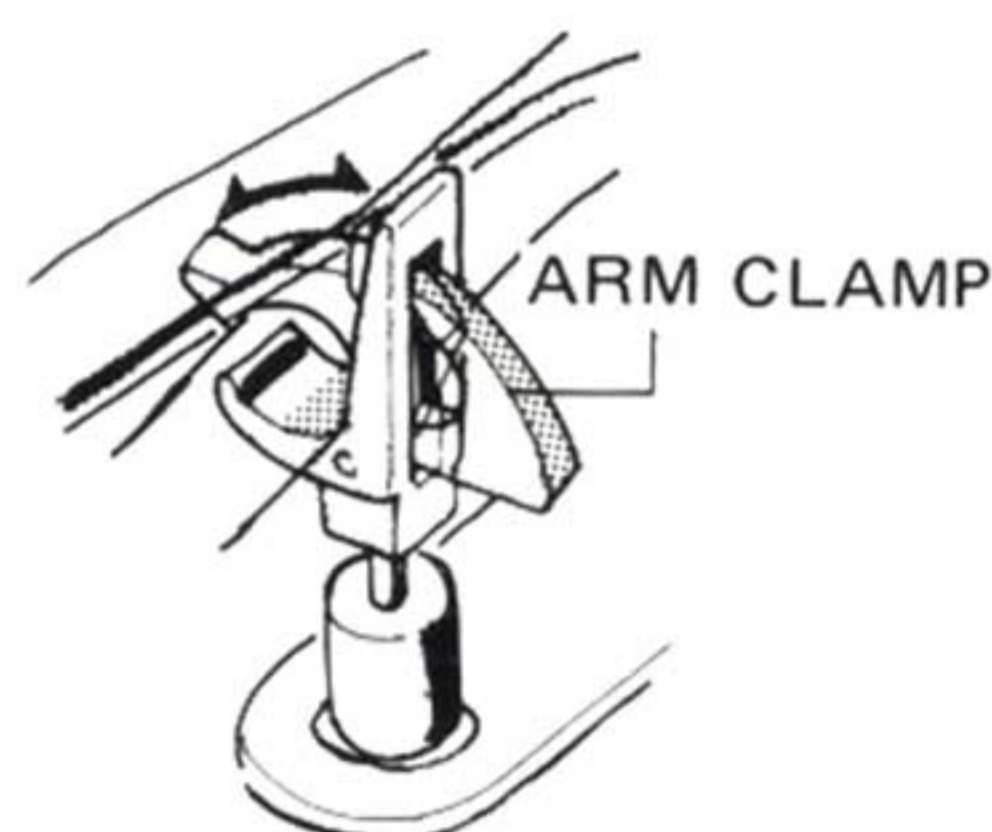

# CARE OF YOUR TURNTABLE

## CLEANING CABINET

Use a polishing cloth or a soft dry cloth to clean dust from the cabinet and dust cover. Do not use household waxes, solvents or sprays on or near the turntable as they can mar the finish.

## LUBRICATION

After a single oiling, the turntable can normally be used stably for about 2000 to 2500 hours. This is equivalent to 1.5 to 2 years in normal usage (an average of 3 to 4 hours per day). Replenishing the oil once within this time period can assure continued high performance. Perform oiling carefully as described below.

1. Remove the dust cover according to "DUST COVER" on page 7.
2. Return the tonearm to the arm rest and clamp it, then protect the stylus tip with the stylus cover.
3. Remove the drive belt from the motor pulley with your fingers (Refer to Fig. 7 on page 4).
4. Lift the turntable platter straight up by inserting fingers and thumb into the two openings (Fig. 19).

If the platter can not be removed easily, try jerking it, taking care not to damage any part of the turntable.

5. Apply one or two drops of the accessory oil to the oiling hole (Fig. 20), being careful not to get oil on parts such as the motor pulley, belt, or inner rim.

### NOTE:

*If oil should adhere to the motor pulley, inner rim, or drive belt, wipe it off with a cloth moistened with pure alcohol.*

*Caution: Never use other solvents.*



Fig. 19

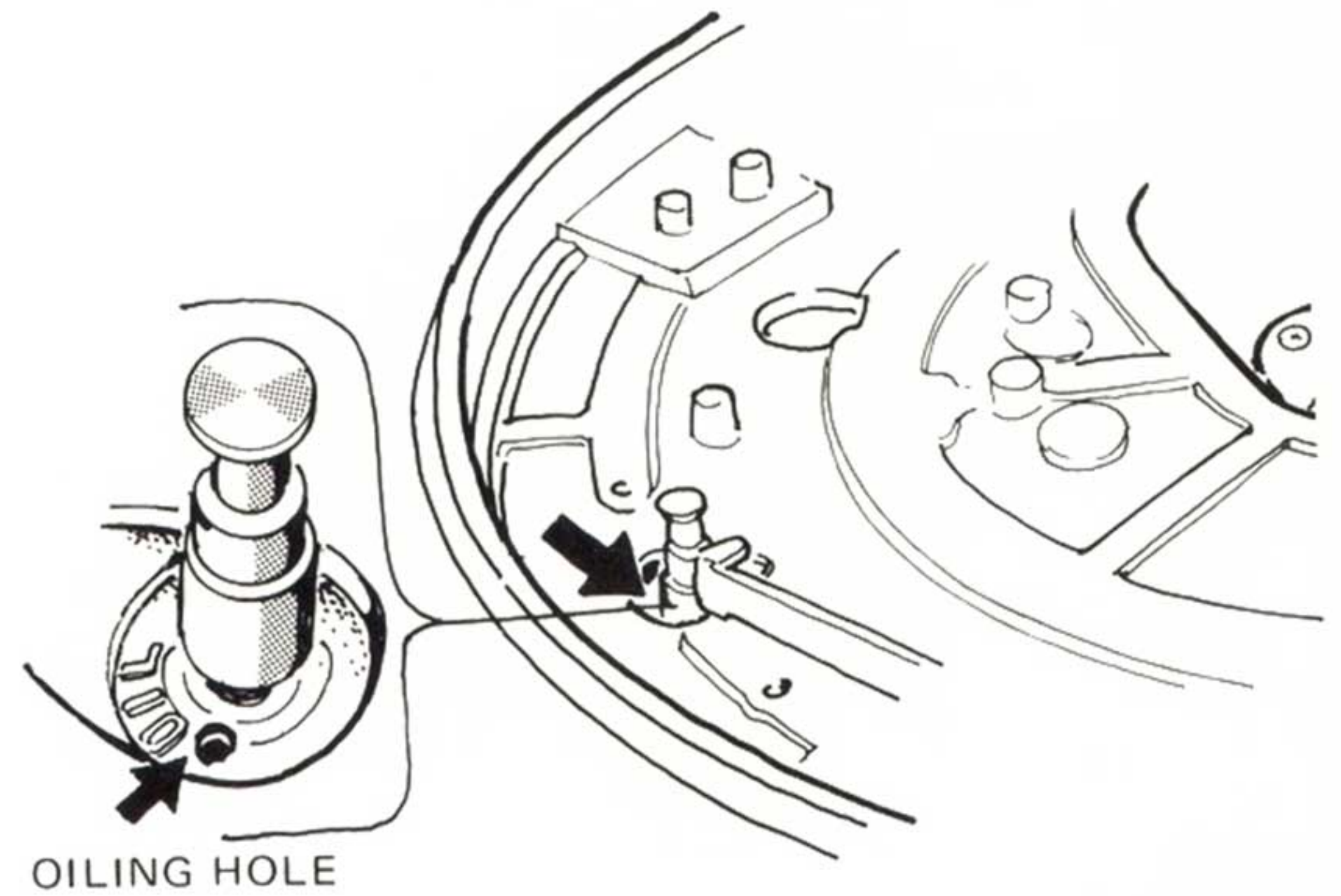

Fig. 20

## CONDITIONS FREQUENTLY MISTAKEN FOR MALFUNCTION

If no sound is obtained from the speakers after assembling this turntable, please check the connections and operation of the other components as follows: (a) internal connection of headshell (e.g. terminal tips, lead wire ...) (b) attachment of locking collar (c) output cord connections (d) speaker wire connections (e) amplifier settings (e.g. VOLUME, FUNCTION, TAPE MONITOR, POWER switch ...)

SYMPTOM	SUSPECTED TROUBLE SOURCES	DIAGNOSIS AND REMEDY
Turntable does not rotate	(a) AC cord is not connected to AC outlet (b) Drive belt is disconnected or loose	Check (a) or (b) and correct the condition
Incorrect turntable speed	(a) Speed select lever is incorrectly set (b) Drive belt is incorrectly fitted (c) Motor pulley and belt are dirty (d) The frequency of your power supply does not suit the PL-112D	Correct the conditions stated in (a) and (b)  Wipe the motor pulley and belt clean with a soft cloth dampened with pure alcohol Contact Pioneer Authorized Service Station
Hum or buzz	(a) Poor connection of shielded wire (b) Jack connection is loose (c) Line cord of fluorescent lamp passes near the shielded wire (d) Poor grounding (e) Shielded wire is running near the Power transformer of the amplifier (f) Ham transmitting station or TV transmitting station is near your house	Correct the conditions stated in (a), (b), (c), (d), or (e) (Reversing the AC connections may occasionally eliminate hum )  In the case of (f), report it to an official authority
Poor tone quality, noise, unclear treble	(a) Stylus is worn (b) Record is worn (c) Dust adhering to stylus (d) Stylus is improperly mounted (e) Stylus pressure is not correct (f) The TREBLE level of the amplifier is too high	Check (a) through (e) and correct the condition  Lower the TREBLE level
Howling	(a) Distance between the turntable and the speakers is too short (b) The turntable or speakers supports are unstable (c) Clamping screws have not been removed	Increase the distance or rearrange the installation of the unit and speakers. (Installing the turntable on a firm, solid stand may alleviate this problem) Do not enhance the BASS sound level excessively  Take out the clamping screws according to Fig. 6 on page 4

# SPECIFICATIONS

## MOTOR AND TURNTABLE

Motor	4-pole synchronous
Turntable drive	Belt-driven
Speed	Two speeds: 33-1/3rpm, 45rpm
Wow and flutter	0.07% (WRMS) or less
S/N	63dB (DIN-B) or more (with Pioneer cartridge model PC-135)
Turntable platter	30cm diam. aluminum alloy
Moment of inertia	135kg-cm <sup>2</sup> (including rubber mat)

## TOEARM

Tonearm type	Static-balance, S-shaped, pipe arm
Effective arm length	221mm
Tracking error	+3° ~ -1°
Overhang	15.5mm
Usable cartridge weight	4g (min.) ~ 10g (Max.)

(For cartridge weighs over 7.0g, attach the sub weight)

## SUBFUNCTIONS

- Anti-skating force control
- Plug-in type headshell
- Oil-damped arm elevator
- Hinges (Free-adjustable)
- Lateral balancer

## MISCELLANEOUS

Power requirements	AC 220 – 240V, 50Hz
Power consumption	10W
Dimensions	440(W) x 362(D) x 159(H)mm 17-5/16(W) x 14-1/4(D) x 6-1/4(H)in.
Weight	6kg, 13lb 2oz

## ACCESSORIES

Headshell	1
Accessory oil	1
Overhang gauge	1
45rpm adaptor	1
Screwdriver	1
Sub weight	1
Cartridge mounting screws	6
Cartridge mounting nuts	2
Cartridge mounting washers	2
Operating instructions	1

**NOTE:**  
Specifications and design subject to possible modification without notice, due to improvements.

For Use in United Kingdom and Australia

**Please note:**

*Models employ 3-conductor mains leads. Please read the following instructions carefully before connecting.*

**WARNING: THIS APPARATUS MUST BE EARTHED.**

**CAUTION 240V: MAINS SUPPLY VOLTAGE IS FACTORY ADJUSTED AT 240 VOLTS.**

### IMPORTANT

The wires in this mains lead are coloured in accordance with following code:

Green-and-yellow:	Earth
Blue:	Neutral
Brown:	Live

*As the colours of the wires in the mains lead of this apparatus may not correspond with the coloured markings identifying the terminals in your plug proceed as follows.*

*The wire which is coloured green-and-yellow must be connected to the terminal in the plug which is marked by the letter E or by the safety earth symbol  $\perp$  or coloured green or green-and-yellow.*

*The wire which is coloured blue must be connected to the terminal which is marked with the letter N or coloured blue or black.*

*The wire which is coloured brown must be connected to the terminal which is marked with the letter L or coloured brown or red.*

*The power cord should be connected last, make sure that the Power switch is OFF.*

*First insert the female appliance connector of the mains cord into the AC inlet, then plug the cord to the wall socket.*

*Be sure the appliance connector is fully inserted into the AC inlet.*

*Unplug the set from the wall socket when it is not to be used for an extended period of time.*

### FOR YOUR SAFETY

1. Insert this plug only into effectively earthed three-pin plug-socket outlet.
2. If any doubt exists regarding the earthing, consult a qualified electrician.
3. Extension cords, if used, must be three-core correctly wired.

## PIONEER ELECTRONIC CORPORATION

4-1, Meguro 1-Chome, Meguro-ku, Tokyo 153, Japan

**U.S. PIONEER ELECTRONICS CORPORATION**

75 Oxford Drive, Moonachie, New Jersey 07074, U.S.A.

**PIONEER ELECTRONIC (EUROPE) N.V.**

Luithagen-Haven 9, 2030 Antwerp, Belgium

**PIONEER ELECTRONICS AUSTRALIA PTY. LTD.**

178-184 Boundary Road, Braeside, Victoria 3195, Australia

Printed in Japan

<PRB-027-B>