



Service Manual

ATS-818 CS

SPECIFICATIONS

FM

TEST ITEM	CONDITION	NOMINAL	LIMIT	UNIT
Tuning Range	Min.	87.5	± 0.15	MHz
	Max.	108.0	± 0.15	MHz
Intermediate Freq.		10.7	± 0.15	MHz
Max. Sens.	90MHz		18	emf dBμ
	98MHz		18	emf dBμ
	106MHz		18	emf dBμ
Useable sens. (S/N 30dB)	90MHz	18	24	emf dBμ
	98MHz	18	24	emf dBμ
	106MHz	18	24	emf dBμ
Calibration	90MHz		± 100	KHz
	98MHz		± 100	KHz
	106MHz		± 100	KHz
Audio Fidelity - 3dB 75μs/50μs (W/Pre-emphasis)	98MHz		150	Hz
	98MHz		12K	Hz
3dB Limiting (10mV)	98MHz	14	20	emf dBμ
Image Rejection	106MHz	42	36	dB
I. F. Rejection	90MHz	60	50	dB
Spurious Rejection	98MHz		50	dB
T. H. D. (75KHz. dev.)	98MHz	1.5	3	%
Lowest Battery Voltage	98MHz	3.8	4.2	V
Output Power at 10% T. H. D.	98MHz	800	700	mW
Alter. Channel Select. 100uV	98MHz		25	dB
Stereo Indicator Sens.	98MHz		24	emf dBμ
Tuning Indicator Sens. (2nd.dot)	98MHz		24	emf dBμ
Stereo Separation (1KHz)	98MHz	25	20	emf dBμ
Auto Scanning Stop Sens.	98MHz		24	emf dBμ
Over Load Capacity	98MHz		100	emf dBμ
Am. Suppression (66 emf dBμ)	98MHz		30	emf dBμ
Min. Output	98MHz		3	mV
Tone Control (10KHz)	98MHz	18	15	dB
S/N (22.5KHz Dev.)	98MHz	58	50	dB
Supply Voltage: DC 6V	R.O.: 50mW	Load: 4 ohm	Modulation: 1KHz 22.5KHz Dev.	

LW

TEST ITEM	CONDITION	NOMINAL	LIMIT	UNIT
Tuning Range	Min.	150	± 5	KHz
	Max.	519	± 5	KHz
Intermediate Freq.	1st. If	55845	± 1	KHz
	2nd. If	450		
Max. Sens.	173KHz		66	dBμ/m
	218KHz		64	dBμ/m
	281KHz		64	dBμ/m
Useable sens. (S/N 20dB)	173KHz	66	72	dBμ/m
	218KHz	64	70	dBμ/m
	218KHz	64	70	dBμ/m
Calibration	173KHz		± 5	KHz
	218KHz		± 5	KHz
	218KHz		± 5	KHz
Lowest Battery Voltage	218KHz	3.8	4.2	V
Tuning Indicator Sens. (2nd.dot)	218KHz		68	emf dBμ
Auto Scanning Stop Sens.	218KHz		70	dBμ/m
S/N Ratio (5mV)	218KHz		24	dB
Supply Voltage: DC 6V	R.O.: 50mW	Load: 4 ohm	Modulation: 1KHz 30% Mod.	

MW

TEST ITEM	CONDITION	NOMINAL	LIMIT	UNIT
Tuning Range	Min.	520	± 5	KHz
	Max.	1620/1710	± 5	KHz
Intermediate Freq.	1st. If 2nd. If	55845 450	± 1	KHz
Max. Sens.	600KHz		56	dBμ/m
	1000KHz		54	dBμ/m
	1400KHz		54	dBμ/m
Useable sens.	600KHz	56	62	dBμ/m
	1000KHz	54	60	dBμ/m
	1400KHz	54	60	dBμ/m
Calibration	600KHz		± 5	KHz
	1000KHz		± 5	KHz
	1400KHz		± 5	KHz
Audio Fidelity (-6dB)	1000KHz		150	Hz
	1000KHz		2200	Hz
A. C. A. (± 10KHz)	1000KHz		46	dB
T. H. D. (5mV)	1000KHz	1.5	3	%
A.G.C. F.O.M.)	1000KHz		40	dB
Image Rejection	1400KHz		36	dB
I. F. Rejection (450KHz)	1000KHz		46	dB
Whistle Modulation (5mV)	2If/3If		15	%
Lowest Battery Voltage	1000KHz	3.8	4.2	V
Tuning Indicator Sens. (2nd.dot)	1000KHz		58	dBμ/m
Auto Scanning Stop Sens.	1000KHz		60	dBμ/m
S/N Ratio (5mV)	1000KHz		35	dB
Out Put Power at 10% T.H.D.	1000KHz	800	700	mW
Bandwidth 6dB (Wide)	1000KHz	6	4-8	KHz
Bandwidth 6dB (Narrow)	1000KHz	4.5	2.5-7	KHz
Supply Voltage: DC 6V	R.O.: 50mW	Load: 4 ohm	Modulation: 1KHz 30% Mod.	

CASSETTE

TEST ITEM	CONDITION	NOMINAL	LIMIT	UNIT
Tape Speed ± 3% 3KHz	MTT-111LN-ST		± 90	Hz
	MTT-111LN-END		± 90	Hz
Wow And Flutter (JIS) Rms	MTT-111LN-ST		0.35	%
	MTT-111LN-END		0.35	%
Play T.H.D.	MTT-112BN	1	3	%
Play S/N Ratio	MTT-112BN	46	40	dB
Play Output Power 10%	MTT-112BN	900	800	mW
Erase Ration W/(1KHz Filter)	MTT-5511		45	dB
	MTT-5561		36	dB
Crosstalk W/(1KHz Filter)	MTT-141N		40	dB
Channel Separation W/(1KHz Filter)	MTT-141N		40	dB
Play Freq Response (1KHz OdB)	MTT-256 125Hz/10KHz		± 6	dB
	MTT-356 125Hz/12.5KHz		± 6	dB
Lowest Battery Voltage		3.8	4.2	V
REC/Play Freq Responsf AT FM 60 emf dBμ 22.5K dev.	MTT-5511 125Hz/8KHz		± 6	dB
	MTT-5561 125Hz/10KHz		± 6	dB
REC Sens AT FM 60emf dBμ 22.5 dev	MTT-5511 1KHz		+(3-8)	dB
	MTT-5511/MTT-118N		+(3-8)	dB
REC Alc AT FM 60emf dBμ dev 22.5/75KHz	MTT-5511 1KHz	-4	-(2-6)	dB
Supply Voltage: 6V	R.O.: 50mV	Load: 4 ohm		

SW

TEST ITEM	CONDITION	NOMINAL	LIMIT	UNIT
Tuning Range	Min.	1621/1711	± 5	KHz
	Max.	29999	± 5	KHz
Intermediate Freq.	1st. If 2nd. If	55845 450	± 1	KHz
Max. Sens.	2300KHz		24	emf dB μ
	15100KHz		22	emf dB μ
	25600KHz		22	emf dB μ
Useable sens. (S/N 20dB)	2300KHz	22	28	emf dB μ
	15100KHz	22	28	emf dB μ
	25600KHz	22	28	emf dB μ
Calibration	2300KHz		± 5	KHz
	15100KHz		± 5	KHz
	25600KHz		± 5	KHz
Audio Fidelity (-6dB)	15100KHz		150	Hz
	15100KHz		2200	Hz
A. C. A. (± 10 KHz)	15100KHz		46	dB μ
SS B/CW Sens S/N: 10dB	15100KHz	-3	3	emf dB μ
T. H. D. (60 emf dB μ)	15100KHz	1.5	3	%
A.G.C. F.O.M. (86 emf dB μ)	15100KHz		50	dB
Image Rejection	15100KHz		30	dB μ
I. F. Rejection (450KHz)	Hz		50	dB
Lowest Battery Voltage	15100KHz	3.8	4.2	V
Tuning Indicator Sens. (2nd.dot)	15100KHz		24	emf dB μ
Auto Scanning Stop Sens.	15100KHz		28	emf dB μ
AM RF Gain VR: Max	15100KHz	-25	± 6	dB
S/N Ratio (60 emf dB μ)	15100KHz		40	dB
Out Put Power at 10% T.H.D.	15100KHz		700	mW
Overload Capacity (80% Mod 10% T.H.D)	15100KHz	90	84	emf dB μ
Bandwidth 6dB (Wide)	15100KHz	6	4-8	KHz
Bandwidth 6dB (Narrow)	15100KHz	4.5	3-7	KHz
Supply Voltage: DC 6V	R.O.: 50mW	Load: 4 ohm	Modulation: 1KHz 30%Mod.	

DISASSEMBLY INSTRUCTIONS

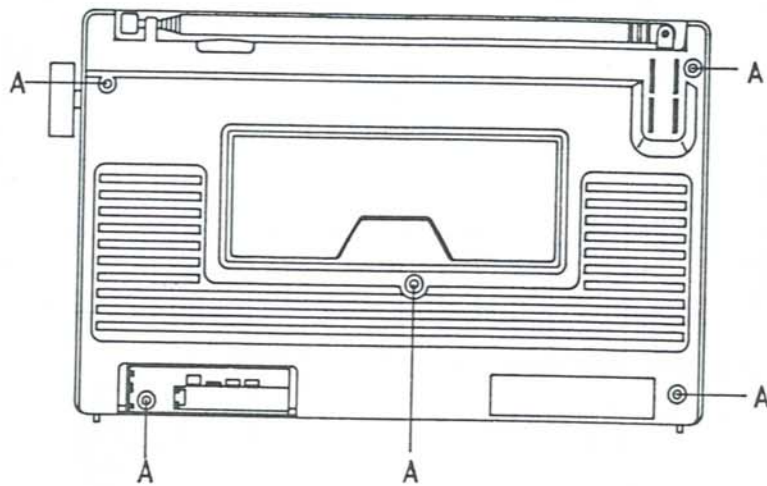

TO REMOVE BACK COVER

- a. Unscrew 5 screw A.
- b. Separate front and back cabinet.

TO REMOVE MAIN PCB

- a. Remove 2 screw C.
- b. Release Main PCB from 2 screws D to remove it.

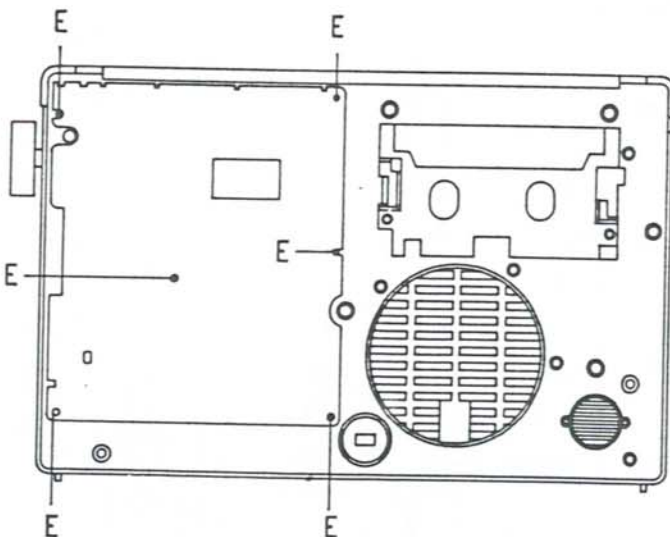
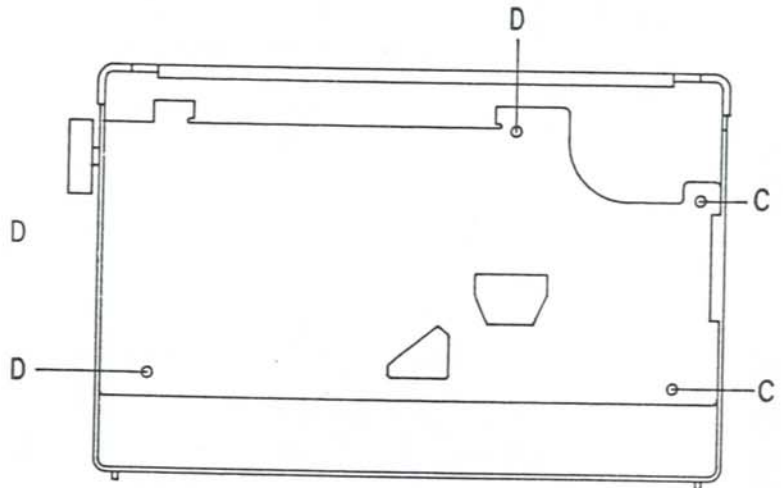

TO REMOVE CONTROL PCB

- a. Release Control PCB from 5 screws E to remove it.

ALIGNMENT INSTRUCTIONS

- Note : (1) All test points are shown both on schematic diagram and figures 1-15.
 (2) Please load in fresh batteries before any alignment procedures.

(1) ALIGNMENT FOR CLOCK TIME ACCURACY

a. Required Instrument
 Frequency Counter

b. Alignment Procedure

Adjustment	Procedure
VC2	(1) Turn the radio to SLEEP ON mode. (2) Set the SAFETY switch upward to electrically lock all push buttons. (3) Remove the batteries from the RADIO BATTERY compartment ,the monitor TIME BASE signal starts functioning. (4) Connect a frequency counter to TP 16 (PIN48 OF IC2) . (5) Adjust VC2 to reach a reading $524288 \pm 4\text{Hz}$ ($\pm 7.6\text{PPM}$ or $\pm 20\text{sec/month}$) on counter.

c. Instrument Connection

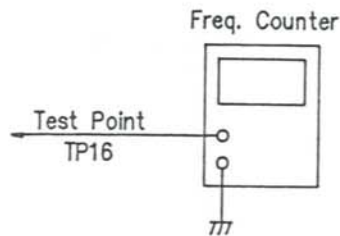

(2) ALIGNMENT FOR PLL FREQUENCY

a. Required Instrument
 Frequency Counter

b. Alignment Procedure

Mode	Adjustment	Procedure
FM	VC1	(1) Turn the radio ON. (2) Select the tuner frequency at 108 MHz. (3) Connect the test probes of frequency counter to TP11 and ground. The ground point should be as near as possible to the test point TP11. (4) Adjust VC1 to have a reading of 118.69975MHz-118.70025MHz.

c. Instrument Connection

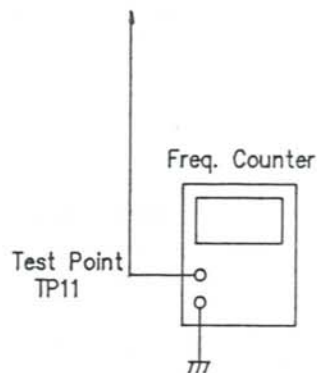

(3) ALIGNMENT FOR AM 2ND LOCAL OSC

- a. Required Instrument
Frequency counter with higher impedance probe.

b. Alignment Procedure

Mode	Adjustment	Procedure
AM	T111	(1) Turn the radio ON. (2) Tune the frequency far away from any station to avoid interference. (3) Connect the test probes of frequency counter to TP8 and ground. (4) Adjust T111 to have a reading of 55.39485MHz-55.39515MHz.

Caution : A loading effect could emerge in the circuit if inserted with a lower impedance probe of frequency counter.

c. Instrument Connection

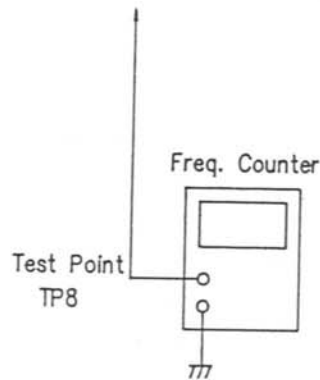

(4) ALIGNMENT FOR AM 2ND IF

- a. Required Instrument
AM IF Sweep Generator with Scope

b. Alignment Procedure

Mode	Adjustment	Procedure
AM	T104 T112	(1) Turn the radio ON. (2) Set the bandwidth switch to WIDE position. (3) Connect the input terminal of AM IF sweep generator in series with a capacitor of 10 μ F to the test point TP5. (4) Connect the RF output terminal of AM IF sweep generator in series with a capacitor 0.1 μ F to another test point TP8. (5) Adjust T104 to have a max. output with a marker frequency of 450kHz on the sweep scope. (6) Adjust T112 to have a max. output with a marker frequency of 450kHz on the sweep scope. (7) Repeat (5) and (6) until a max. 450kHz output is reached.

c. Instrument Connection

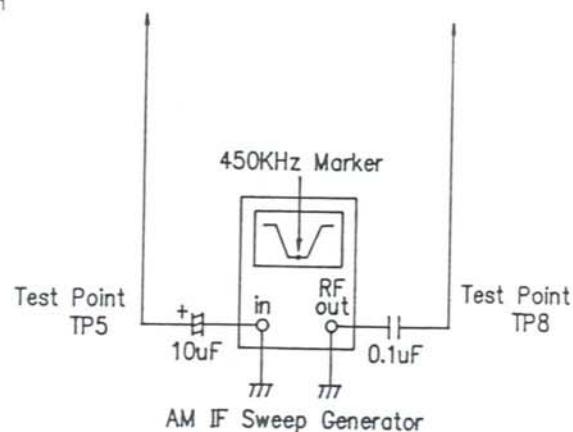

(5) ALIGNMENT FOR FM IF

- a. Required Instruments
FM IF Sweep Generator with Scope.

b. Alignment Procedure

Mode	Adjustment	Procedure
FM	T103 T105	<ol style="list-style-type: none"> Turn the radio ON. Connect the input of FM IF sweep generator in series with a resistor of 1.2K ohm to the test point TP5. Connect the RF output of FM IF sweep generator in series with a resistor of 2.2K ohm to another test point TP3. Adjust T103 and T105 to have a max output and best symmetrical S curve with respect to the center marker frequency of 10.7MHz.

c. Instrument Connection

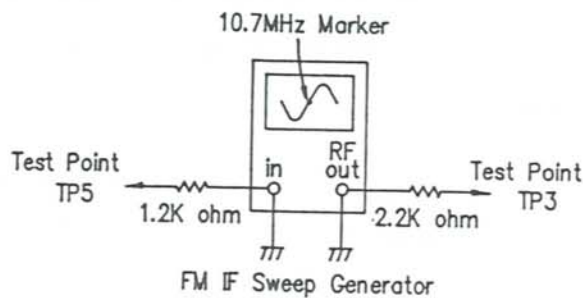

(6) ALIGNMENT FOR AM SENSITIVITY

- a. Required Instruments
AM Signal Generator
SSVM
Frequency Counter

b. Alignment Procedure

Mode	Adjustment	Procedure
AM	T108 T109 T110 T111	<ol style="list-style-type: none"> Turn the radio ON. Set the bandwidth switch to WIDE and RF GAIN VR to MAX position. Tune the radio band frequency to 15.100MHz. Feed a signal with modulation from AM signal generator output to the test point TP1 and connect a SSVM to speaker (TP14). Tune the generator frequency exactly the same as that of the radio frequency displayed. Adjust T108, 109, 110 to have a max. audio output. Connect the probe of frequency counter at the test point TP4. Adjust T111 to meet the specification frequency $450\text{kHz} \pm 0.15\text{kHz}$. Remove the counter and repeat (6) to (8) until the specification frequency is met.

c. Instrument Connection

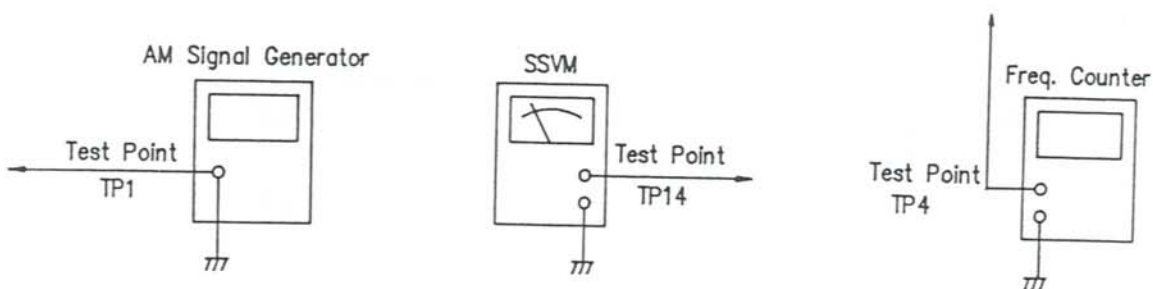

(7) ALIGNMENT FOR FM SENSITIVITY

- a. Required Instruments
 FM Signal Generator
 SSVM

b. Alignment Procedure

Mode	Adjustment	Procedure
FM	T101 T102 TC101 TC102	(1) Turn the radio ON. (2) Connect a SSVM to speaker (TP14). (3) Connect a FM signal generator to the input terminal of Rod Ant. (TP2). (4) Set the signal generator to 22.5kHz deviation with 1kHz modulation. (5) Tune the radio band frequency to 90MHz and adjust T101,T102 to have a max. reading on SSVM. (6) Return the radio band frequency to 106MHz and adjust TC101,TC102 to have a max. reading on SSVM. (7) Repeat (5) and (6) until a best sensitivity on these two frequencies are formed.

c. Instrument Connection

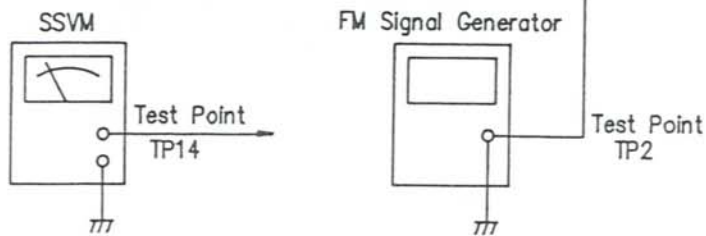

(8) ALIGNMENT FOR MPX

- a. Required Instrument
 Frequency Counter

b. Alignment Procedure

Mode	Adjustment	Procedure
FM	VR102	(1) Turn the radio ON. (2) Set the FM mode switch to STEREO position. (3) Insert a plug of headphone into the HEADPHONE JACK (J3) (4) Connect the test point TP5 in series with a capacitor of 1μF to ground. (5) Connect a frequency counter to TP6. (6) Adjust VR102 to have a reading of 18.95kHz-19.05kHz on frequency counter.

c. Instrument Connection

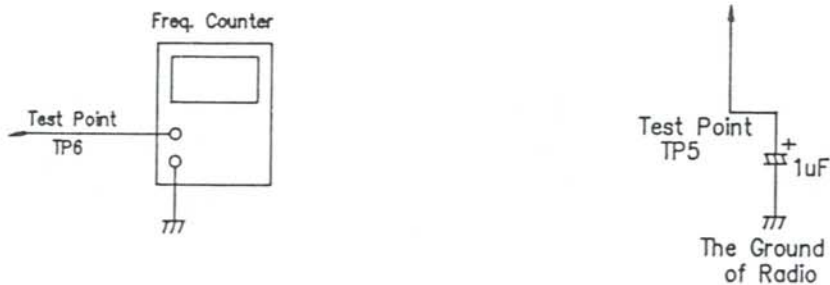

(9) ALIGNMENT FOR INDICATION LEVEL OF BATTERY

- a. Required Instrument
DC Power Supply with voltage meter

b. Alignment Procedure

Adjustment	Procedure
VR105	(1) Remove batteries away from the RADIO BATTERY compartment. (2) Connect a DC power supply to the test point TP12. (3) Set the voltage to a reading of 4.4V. (4) Turn the radio ON and adjust VR105. (5) Push POWER key again to shut off the radio and the BATTERY LEVEL INDICATOR will immediately appeared on LCD for a period of 5 seconds. (6) Repeat (4) and (5) until the level was indicated on the 2nd. scale.

c. Instrument Connection

Regulated DC Power Supply

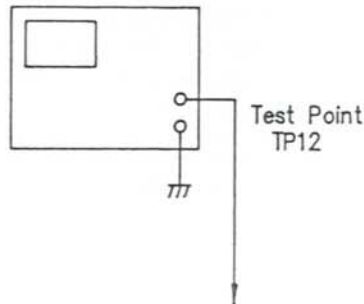

(11) ALIGNMENT FOR 450kHz TRAP

- a. Required Instruments
AM Signal Generator
Loop Antenna
SSVM

b. Alignment Procedure

Mode	Adjustment	Procedure
AM	T115	(1) Turn the radio ON. (2) Set the bandwidth switch to WIDE and RF GAIN VR to MAX position. (3) Tune the radio band frequency to 450kHz. (4) Connect a AM aignal generator together with standard loop dummy antenna and feed a stronger signal to the MW/LW ferrite bar antenna. (5) Tune the generator frequency to 450kHz and set modulation depth to 30%~50% (6) Connect a SSVM to speaker (TP14). (7) Adjust T115 to have a min. audio output.

c. Instrument Connection

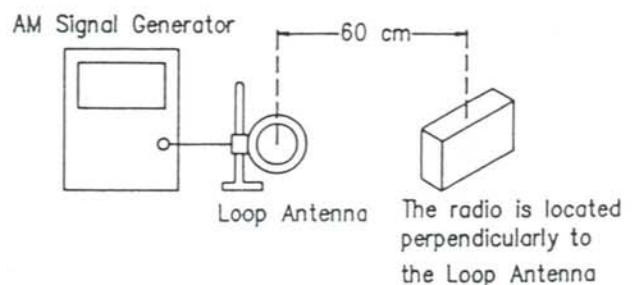
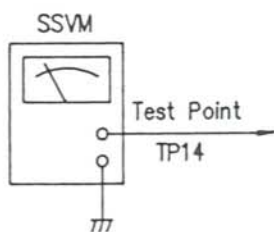

(10) ALIGNMENT FOR SIGNAL STRENGTH LEVEL

- a. Required Instrument
FM Signal Generator
AM Signal Generator

b. Alignment Procedure

Mode	Adjustment	Procedure
FM	VR106	(1) Turn the radio ON. (2) Connect a FM signal generator to the input terminal of Rod Ant. (TP2) (3) Set the signal generator to 98MHz with 1kHz Mod, 22.5Hz deviation and 36 emf dB μ /75 ohm output level. (4) Tune the radio band frequency to 98MHz and adjust VR106 to have a strength level reading of 6th scale.
AM	VR104	(1) Turn the radio ON. (2) Set the bandwidth switch to WIDE and RF GAIN VR to MAX position. (3) Tune the radio band frequency to 15.100MHz. (4) Feed a signal with 30% modulation and 36 emf dB μ /50 ohm output level into the AM EXT. ANT. Jack. (5) Tune the generator frequency exactly the same as that of the radio frequency displayed (6) Adjust VR104 to have a strength level reading of 5th scale.

Caution : Before these signal strength alignment procedures, the VR105 (for Battery level) should be in correct position.

c. Instrument Connection

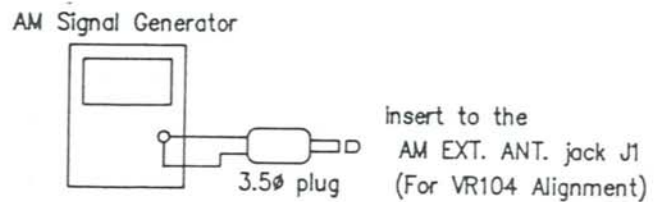
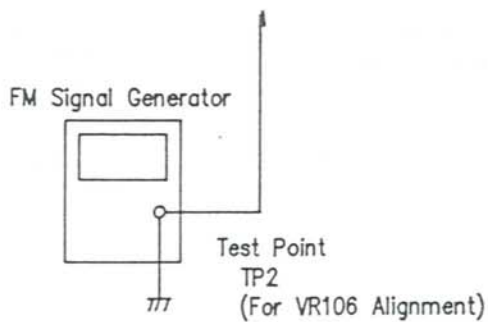

(12) ALIGNMENT FOR BFO

- a. Required Instrument
Signal Generator
SSVM

b. Alignment Procedure

Mode	Adjustment	Procedure
AM	TC103	(1) Set the power switch to ON position. (2) Set the band to SW, BFO switch to ON and BFO pitch to center position. (3) Feed a signal without modulation from signal generator to EXT ANT jack, and connect a SSVM to the speaker. (4) Tune the radio frequency exactly the same as that of signal generator. (5) Adjust TC103 to have a minimum reading on SSVM.

c. Instrument Connection

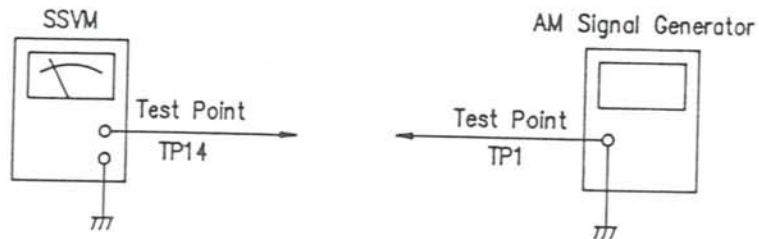

(13) ALIGNMENT FOR FM AUTO STOP ACCURACY

- a. Required Instrument
FM Signal Generator
SSVM

b. Alignment Procedure

Mode	Adjustment	Procedure
FM	VR101	(1) Set the power switch to ON. (2) Set FM 98 MHz. (3) Connect a the output of the FM signal generator to (TP1). (4) Connect SSVM to the pin 14 of IC2 (TP17). (5) Tune the band frequency to 98MHz and adjust VR101 to have a max. 1V (show on the SSVM). (6) Set FM signal generator 98.05 and 97.95 MHz to have a min. 5V (show on SSVM). (7) Repeat step 5 and 6.

c. Instrument Connection



(14) ALIGNMENT FOR HEAD AZIMUTH

- a. Required Instrument
 SSVM
 TEST TAPE (TEAC MTT-114N or equivalent)

b. Alignment Procedure

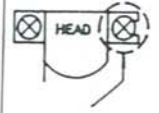
Mode	Adjustment	Procedure
TAPE PLAY	 HEAD AZIMUTH SCREW	(1) Take OFF the cassette door (2) Load the TEST TAPE in. (3) Set TONE VR and VOL VR to max position (4) Depress the PLAY KEY (5) Adjust HEAD AZIMUTH SCREW to have a max. ON VTVM reading

c. Instrument Connection

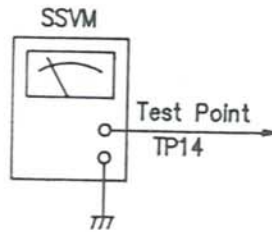

(15) ALIGNMENT FOR TAPE SPEED

- a. Required Instrument
 Frequency Counter
 TEST TAPE (TEAC MTT-114N or equivalent)

b. Alignment Procedure

Mode	Adjustment	Procedure
TAPE PALY	 TAPE SPEED ADJ. VR	(1) Take OFF the cassette door (2) Load the TEST TAPE in. (3) Adjust TAPE SPEED ADJ. VR to have a reading of $3000\text{Hz} \pm 3\%$ ($2910\text{Hz} - 3090\text{Hz}$)

c. Instrument Connection

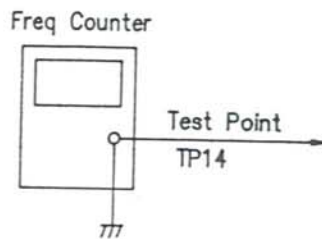

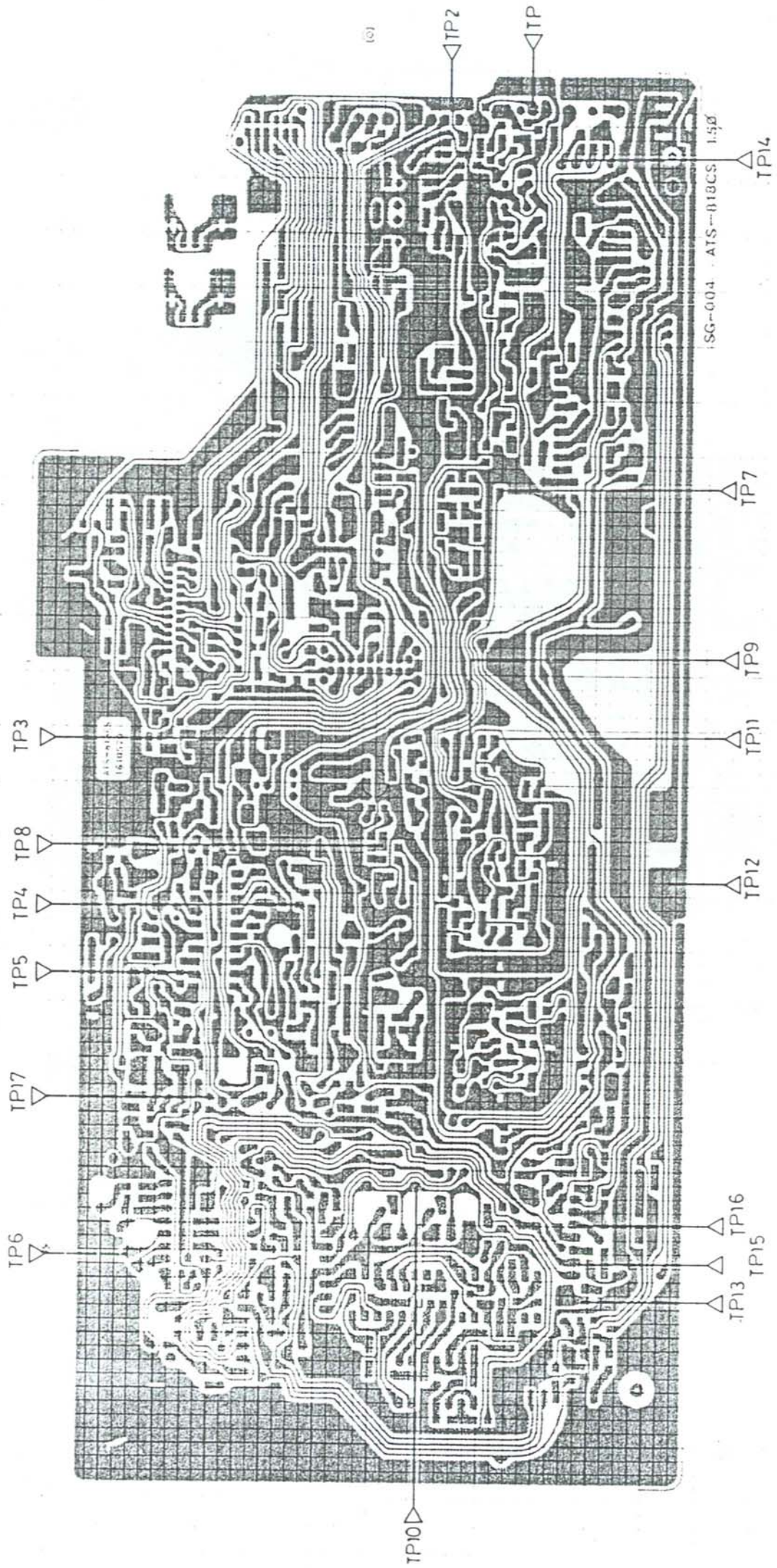

SEMICONDUCTOR LEAD IDENTIFICATION

Transistors



2SK212E



2SC2999D/E
2SC2839E

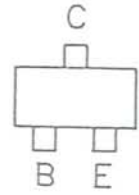

2SC1623L6/L7
2SB815B6-TA/B7
2SA812M6/M7
2SD1048X6/X7



2SA1020Y



2SK381A/B



2SK715W



SVC-203

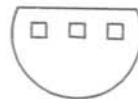

SVC-201SP

(E: Emitter C: Collector B: Base S: Source G: Gate D: Drain)

Diodes



1N4148T
1N60



1SS98T



1SS238T
UZ-15BH



RL-S4148

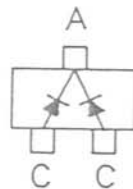

1S2837A5

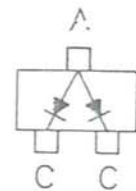

1S2835-T2B-A3

(A: Anode C: Cathode)

		FM	AM
Q144	E	0	0
	B	0.6	0.6
	C	0.2	0.2
Q147	E	6.0	6.0
	B	5.9	5.9
	C	0	0
Q148	E	0	0
	B	0	0
	C	0	0
C151	E	0	0
	B	0	0
	C	0	0
Q158	E	0	0
	B	0	0
	C	0	0
Q159	E	0	0
	B	0	0
	C	0	0

		Radio	Tape
Q131	E	3.0	3.0
	B	2.4	5.4
	C	2.96	0.2
Q149	E	0	6.0
	B	0	5.3
	C	0	5.9
Q150	E	0	0
	B	0	0.6
	C	0	0.3
Q153	E	0	1.78
	B	0.47	2.38
	C	0	1.8
Q154	E	0	0 (CRO2)
	B	0	0.66(CRO2)
	C	0	0 (CRO2)
Q155	E	0	5.47(CRO2)
	B	0	4.86(CRO2)
	C	0	5.44(CRO2)
Q157	E	0	0
	B	0.6	1.01
	C	0.2	0.42
Q146	E	5.6	5.7
	B	4.8	5.3
	C	5.55	0.4
Q145	E	4.6	1.6
	B	4.7	1.1
	C	2.5	1.3

		Radio	Tape	
			Play	Cue Review
Q160	E	0.1	5.78	5.78
	B	0.24	5.76	5.03
	C	-1.07	-1.1	5.73
Q161	E	0	0	0
	B	-1.18	-1.12	0.64
	C	0	1.78	0

STANDBY RELEASE

		Off	On
Q140	E	6.0	6.0
	B	6.0	6.0
	C	0	5.9
Q141	E	0	0
	B	0	0.6
	C	5.9	0.2
TYPE		PLAY	REC
Q152	E	0	0.04
	B	0	0.5
	C	5.9	1.5

		FM	AM
Q132	E	0	(LW) (MW) 0.2
	B	0	(LW) (MW) 0
	C	0	(LW) (MW) 4.5
Q133	E	8.3	2
	B	8.1	1.8
	C	1.5	2.8
Q134	E	0	0
	B	0	0.66
	C	0	0
Q135	E	0	0
	B	0	0
	C	0	0.66
Q136	E	0	5.47
	B	0	5.44
	C	0	0
Q137	E	0	5.47
	B	0	4.86
	C	0	5.44
Q138	E	0.3	0.3
	B	0.9	0.9
	C	1.9	1.9
Q139	E	0.3	0.3
	B	0.9	0.9
	C	1.9	1.9
Q142	E	6.0	6.0
	B	5.4	5.4
	C	5.8	5.8
Q143	E	6.0	6.0
	B	5.4	5.4
	C	5.9	5.9

LIGHT

Pin No.	Off	On
1	5.8	5.8
2	5.8	5.8
3	0	0
4	0	5.8
5	5.8	5.8

IC103

Pin No.	FM	AM
1	5.6	5.6
2	0	0
3	3.0	3.0
4	5	5

		FM	AM
Q111	E	0	0.5
	B	0	0
	C	0	0
Q112	E	0	0
	B	0	0.68
	C	0	1.12
Q113	E	0	0.3
	B	0	0.66
	C	0	1.2
Q114	S	0	(SSB) 0
	G	0	(SSB) 0.6
	D	0	(SSB) 0
Q115	E	3.00	3.00
	B	4.9	2.4
	C	0	2.9
Q116	E	0	0
	B	0.6	0
	C	0	1.5
Q117	E	2.7	2.7
	B	3.3	3.3
	C	2.8	2.8
Q118	E	0	0
	B	0.72	0.72
	C	1.73	1.73
Q119	E	0.6	0.6
	B	1.3	1.3
	C	1.5	1.5
Q120	E	0	0
	B	0.7	0.7
	C	1.64	1.64

		FM	AM
Q121	E	0	0
	B	0.25	0.2
	C	3.00	3.00
Q122	E	0	0
	B	-1.88	(LW) 0 (MW) 0
	C	-0.38	(LW) 0 (MW) 0
Q123	E	0	(LW) 0 (MW) 0
	B	-0.38	(LW) 0 (MW) 0
	C	5.62	(LW) 0 (MW) 0
Q124	E	5.67	(LW) 5.67 (MW) 5.67
	B	5.1	(LW) 5.5 (MW) 5.5
	C	5.64	(LW) 0.3 (MW) 0.3
Q125	S	5.6	(LW) 5.6 (MW) 5.6
	G	5.5	4.9
	D	0	5.5
Q126	E	0	3.00
	B	0	2.45
	C	0	0
Q127	E	0	0
	B	0	0.6
	C	1.36	0
Q128	E	0	0
	B	0.6	0
	C	0	1.22
Q129	E	0	0
	B	0	0
	C	0	2.44
Q130	E	5.55	5.55
	B	4.86	5.43
	C	5.5	0

Transistors

		FM	AM
Q1	E	0	0
	B	0.61	0
	C	0.07	5.30
Q2	E	0	0
	B	0	0.61
	C	4.93	0.07
Q3	E	0	0.92
	B	0	0
	C	0.46	5.96
Q4	E	0	0
	B	0.66	0.66
	C	0.07	0.07
Q5	E	0	0
	B	0	0
	C	6.00	6.00
Q6	E	0.93	0.94
	B	0.68	0.69
	C	2.63	2.63
Q7	E	0	0
	B	0.61	0.61
	C	9.3	1.2
Q8	E	0	0
	B	0	0.6
	C	5.8	0.3
Q9	E	0.51	0.51
	B	1.35	1.35
	C	3.00	3.00
Q10	E	3.00	3.00
	B	2.6	2.6
	C	3.00	3.00

		FM	AM
Q101	E	0	(LW) (MW) 0
	B	0	(LW) (MW) 0.6
	C	0	(LW) (MW) 0
Q102	E	0	0
	B	0	0
	C	4.02	0
Q103	E	0	0
	B	0.65	0
	C	4.00	0
Q104	E	0	0
	B	0.6	0.6
	C	0	0
Q105	E	0	0
	B	0	0.7
	C	0	0
Q106	E	0	(SSB) 0.02
	B	0	(SSB) 0.6
	C	0	(SSB) 1.36
Q107	E	0	(SSB) 0
	B	0	(SSB) 0.6
	C	0	(SSB) 1.2
Q108	E	0	0.24
	B	0	0
	C	0	4.75
Q109	E	0	0.37
	B	0	0
	C	0	0.37
Q110	E	0	0.37
	B	0	0
	C	0	3.7

IC106

Pin No.	PLAY	REC
1	5.86	5.86
2	1.8	1.8
3	2.0	2.0
4	2.0	2.0
5	2.0	2.0
6	0	0
7	2.0	2.0
8	2.0	2.0
9	2.0	2.0
10	2.0	2.0
11	0	0
12	2.0	2.0
13	0	0
14	2.0	2.0
15	2.0	2.0
16	2.0	2.0
17	2.0	2.0
18	0	1.8
19	2.0	2.0
20	0	0
21	2.0	2.0

IC5

Pin No.	FM	AM
1	5.8	5.8
2	0	0
3	3	3

IC1

Pin No.	FM	AM
1	-1.38	-1.37
2	0	0
3	0	0
4	3.0	3.0
5	1.2	1.2
6	1.11	1.11
7	0.68	0.68
8	0.01	0.01
9	0.01	0.01
10	0	0
11	1.4	1.39
12	2.88	2.88
13	0	0
14	0	0

IC109

Pin No.	FM	AM
1	5.9	5.9
2	0	0
3	3.2	3.2
4	0.6	0.6
5	5.7	5.7
6	5.9	5.9
7	0	0
8	1.4	1.4
9	0	0

IC108

Pin No.	FM	AM
1	3.00	3.00
2	3.00	3.00
3	3.00	3.00
4	3.00	3.00
5	0	0
6	3.00	3.00
7	3.00	3.00
8	0	0
9	3.00	3.00
10	0	0
11	3.00	3.00
12	3.00	3.00
13	3.00	3.00
14	0	0
15-16	3.00	3.00

IC107

Pin No.	FM	AM
1	5.9	5.9
2	0	0
3	3.2	3.2
4	0.6	0.6
5	5.7	5.7
6	5.9	5.9
7	0	0
8	1.4	1.4
9	0	0

IC2

Pin No.	FM	AM
1-15	LCD Segment	
16	1.57	1.57
17	3.2	0
18	0	3.2
19	0	0
20	0	0
21-24	LCD Back Plane	
25	3.7	3.7
26	3.7	3.7
27	2.15	2.15
28	1.08	1.08
29	3.66	3.66
30	0	0
31	0	0
32	0	0
33	0	0
34	0	0
35	0	0
36	0	0
37	3.66	3.66
38	3.2	
39	3.66	3.66
40	3.66	3.66
41	3.66	3.66
42	3.66	3.66
43	3.66	3.66

IC2

Pin No.	FM	AM
44	3.66	3.66
45	3.66	3.66
46	0	0
47	0	0
48	0	0
49	0	0
50	0	0
51	0	0
52	0	0
53	3.7	3.7
54	3.7	3.7
55	0	0
56	3.7	3.7
57	0	0
58	1.47	1.47
59	1.50	1.50
60	3.1	3.1
61	3.7	3.7
62	3.7	3.7
63	3.7	3.7
64	3.7	3.7
65	3.7	3.7
66	3.7	3.7
67	3.7	3.7
68	3.7	3.7
69-80	LCD Segment	

IC105

Pin No.	FM	AM
1	3.66	3.66
2	3.66	3.66
3	3.66	3.66
4	0	0
5	1.05	0.88
6	0.75	0.70
7	0.94	0.79
8	0.75	0.7
9	0.97	0.82
10	0.75	0.7
11	1.05	0.88
12	0	0
13-14	3.66	3.66

IC AND TRANSISTOR VOLTAGE CHART

IC101

Pin No.	FM	AM
1	4.39	3.80
2	1.66	1.66
3	1.83	1.60
4	1.27	1.79
5	1.38	1.60
6	1.38	1.60
7	5.35	5.30
8	2.60	2.25
9	5.35	5.30
10	5.05	0
11	0	0
12	1.50	1.59
13	0	2.35
14	2.97	2.97
15	1.12	1.08
16	1.12	1.08
17	2.38	2.33
18	1.77	1.46
19	1.66	-1.66
20	1.66	1.66

IC102

Pin No.	FM	AM
1	2.86	2.86
2	0.46	0.46
3	0.46	0.46
4	0.93	0.93
5	0.93	0.93
6	0.02	0.02
7	2.99	2.99
8	0	0
9	1.04	1.04
10	0.45	0.45
11	1.17	1.17
12	1.32	1.32
13	1.43	1.43
14	1.15	1.15
15	1.15	1.15
16	0.02	0.02

IC104

Pin No.	FM	AM
1	3.00	3.00
2	3.00	3.00
3	3.00	3.00
4	0.75	0.75
5	1.11	0.94
6	0.75	0.70
7	1.19	1.00
8	0.75	0.7
9	1.24	1.04
10	0.75	0.7
11	1.27	1.07
12	0	0
13-14	3.00	3.00

IC4

Pin No.	FM	AM
1	4.2	4.2
2	0	0
3	3.00	3.00

Testing Conditions:

1. No input signal and volume set to minimum.
2. Speaker mode.
3. External antenna is not used.
4. AM is received by 150kHz and put on the wide. BFO is off, and AM RF gain is maximum.
5. FM is received by 98MHz and set to the stereo position.
6. Install a 6.0V radio battery and a 4.5V backup battery.
7. Unit of measure: volts.

4. IC4, 5-S-81230AG-RE-T2

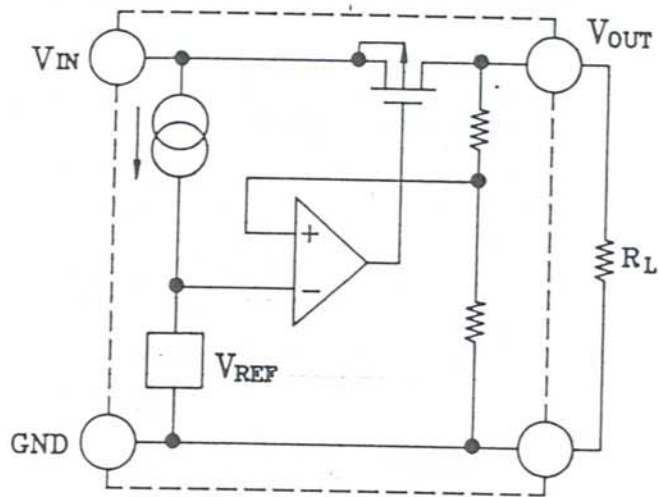

5. IC101-TA7758P

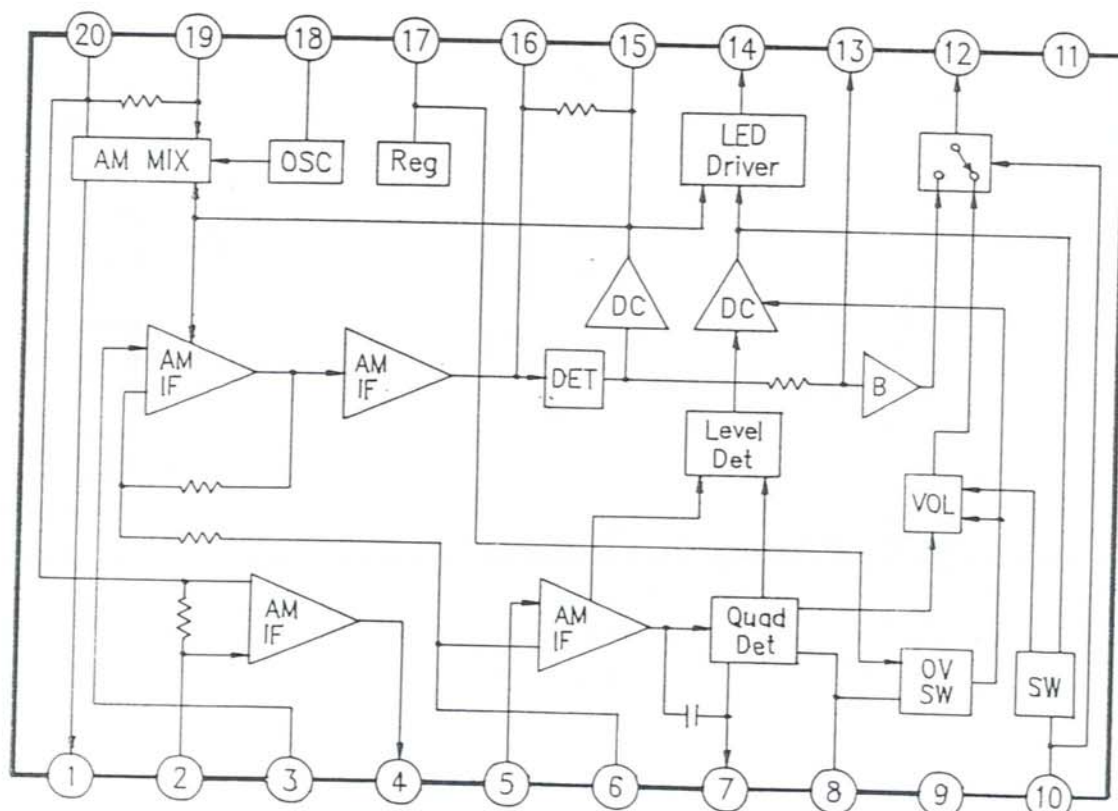

6. IC102-AN7415

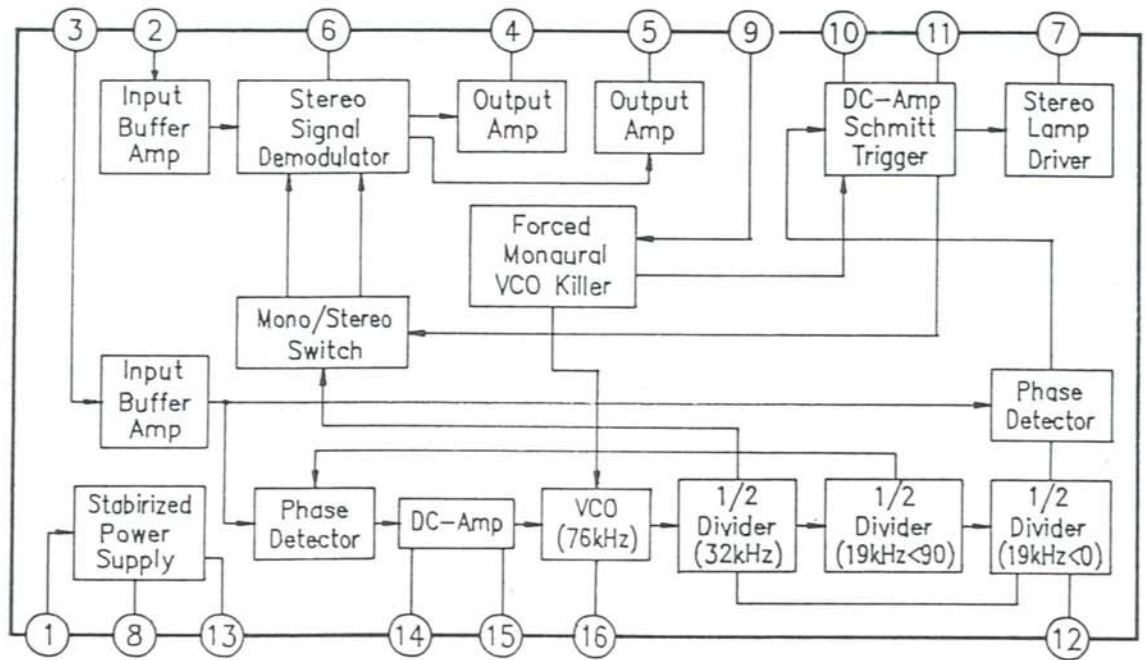

7. IC103-LA5003

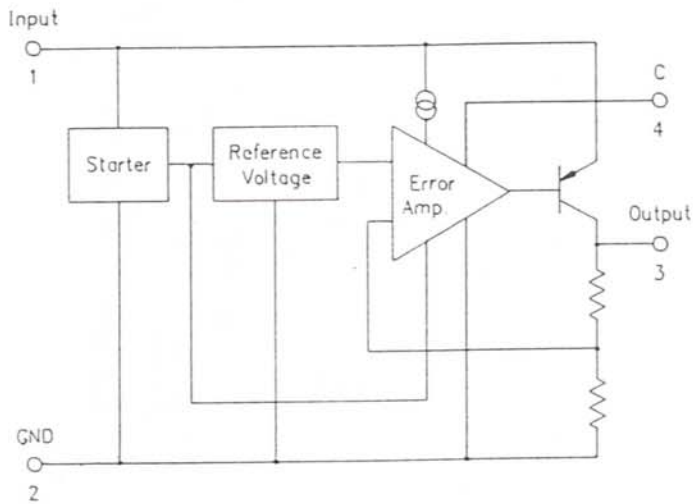

8. IC104, 105-TA75339P

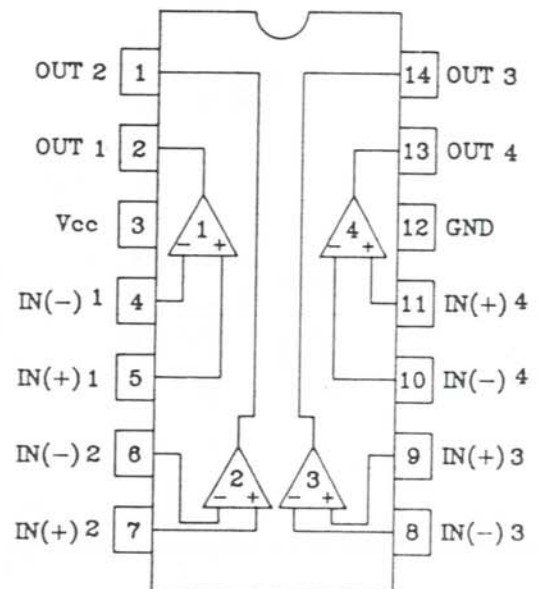

9. IC106-TA7417AP

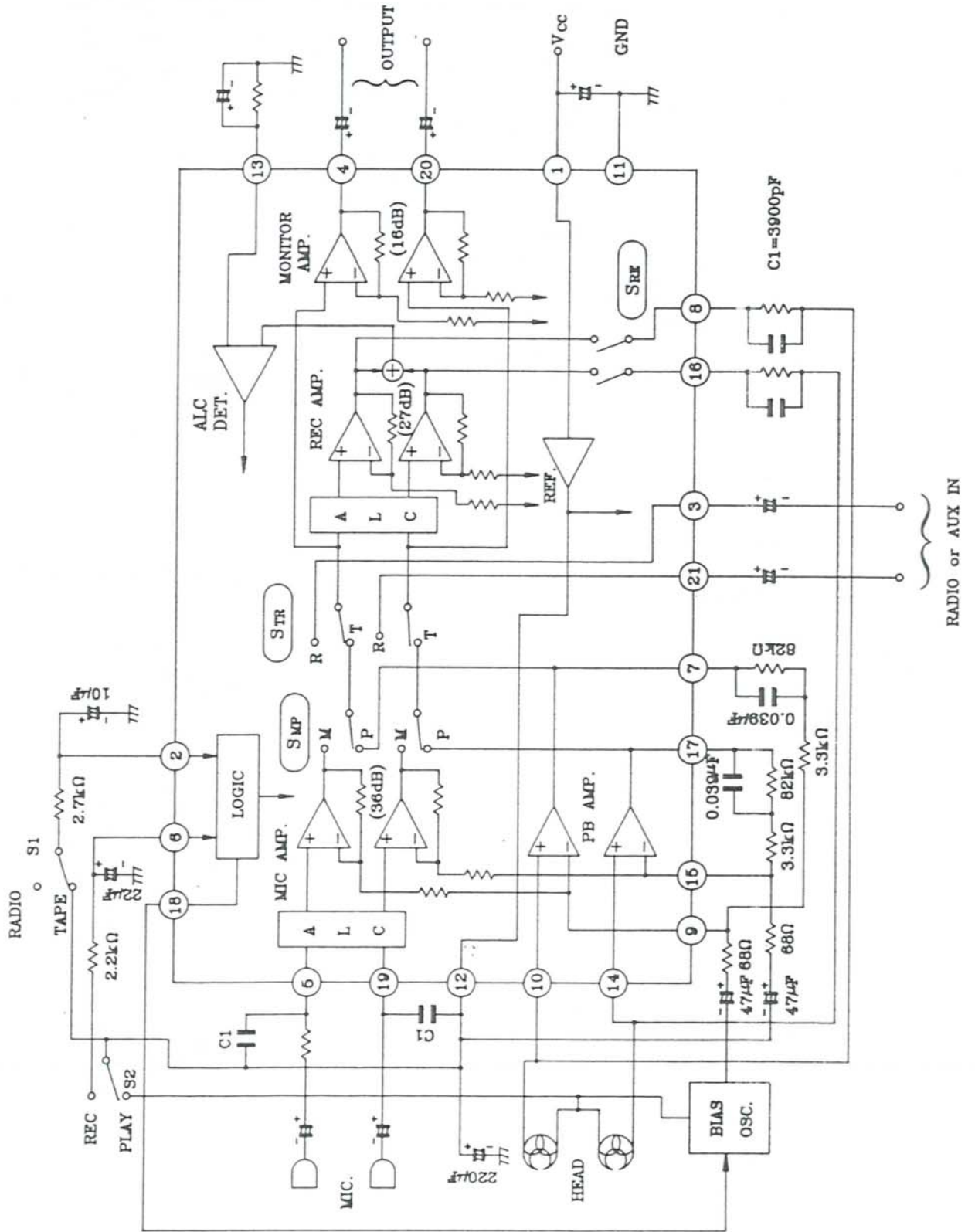

10. IC107, 109-AN7141N

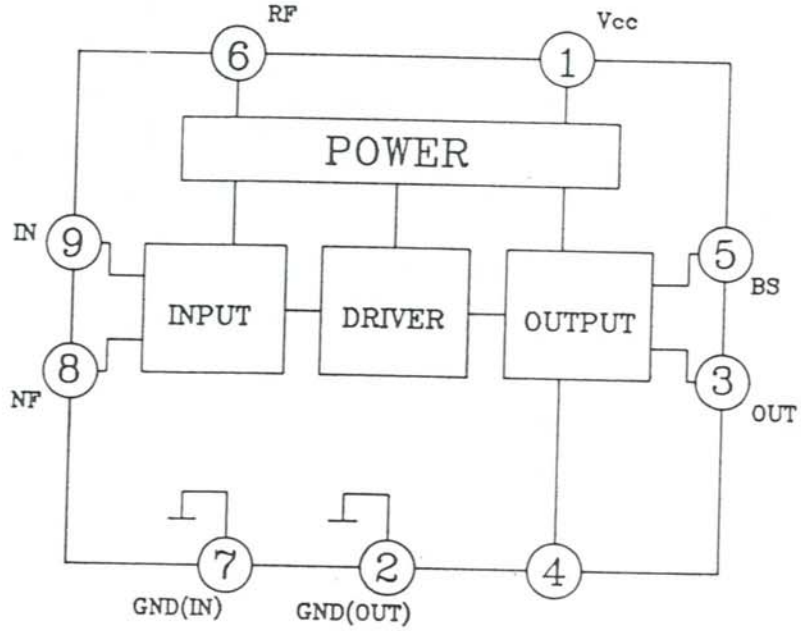

11. IC108-TC74HC148AP

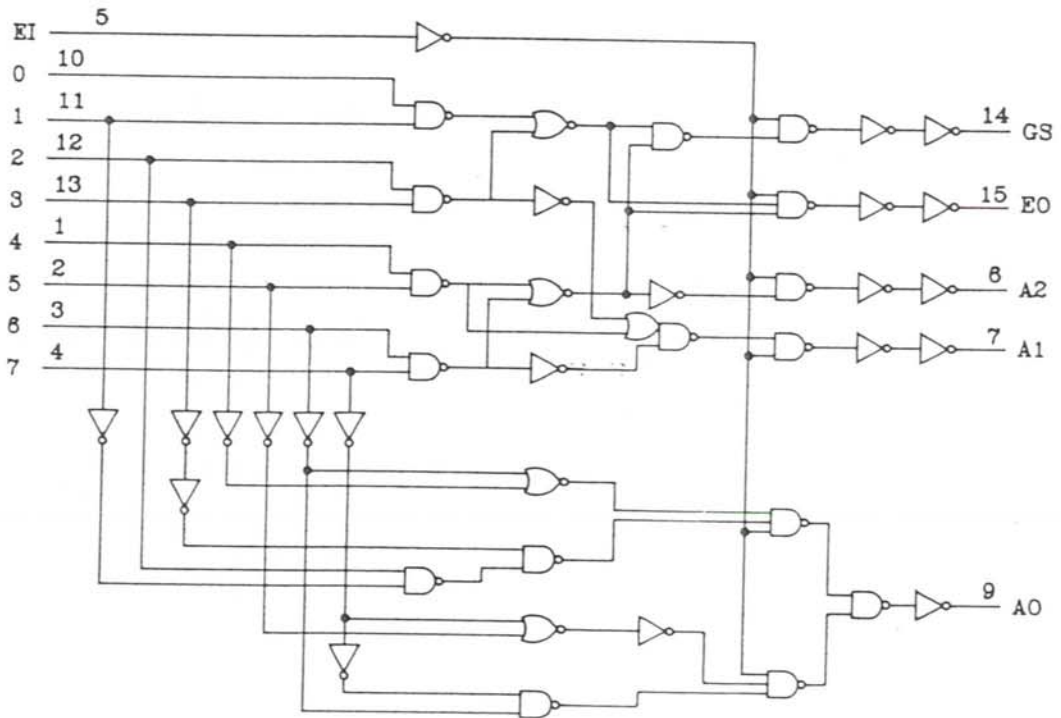

SCHEMATIC DIAGRAM

機型MODEL NO.	品名TITLE	圖號DWG NO.	檢圖CHECKED	製圖DRAWN
81S-818CS	CIRCUIT DIAGRAM	81S-818CS	HWANG	
81.02.19	DATE	81.01.31	DATE	82.8.5
81.02.19	DATE	81.01.31	DATE	82.8.5
山進電子工業股份有限公司 SANGSEAN ELECTRONICS INC.				

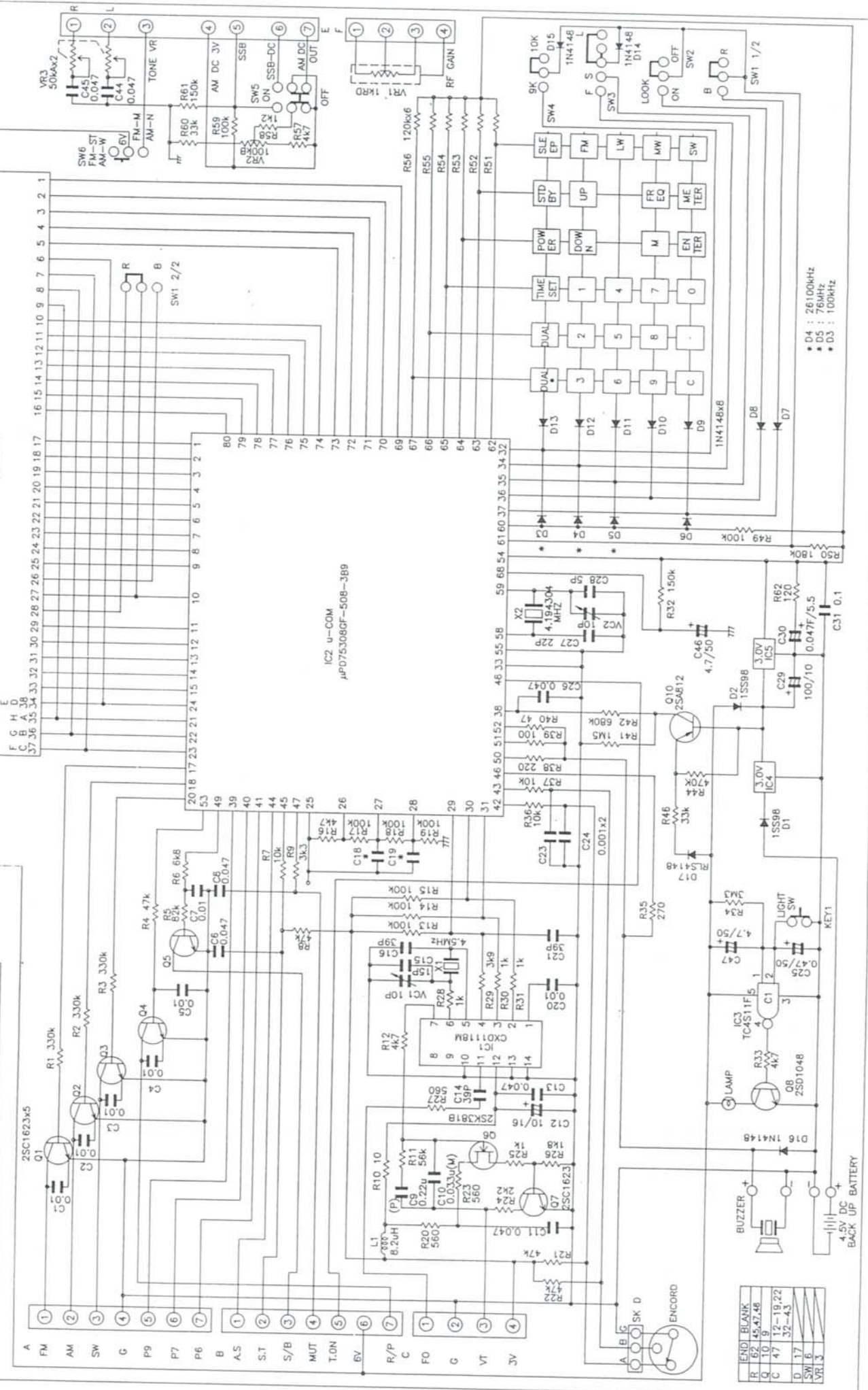

IC CIRCUIT BLOCK DIAGRAMS

1. IC1-CXD1118M-1

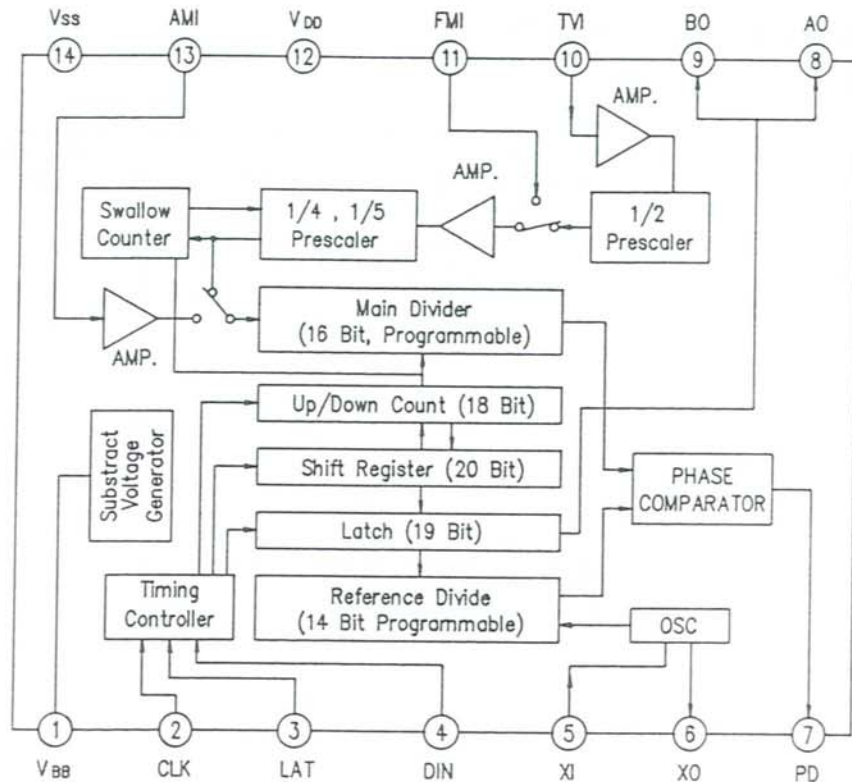

2. IC2-UPD 75308GF-508

3. IC3-TC4S11F

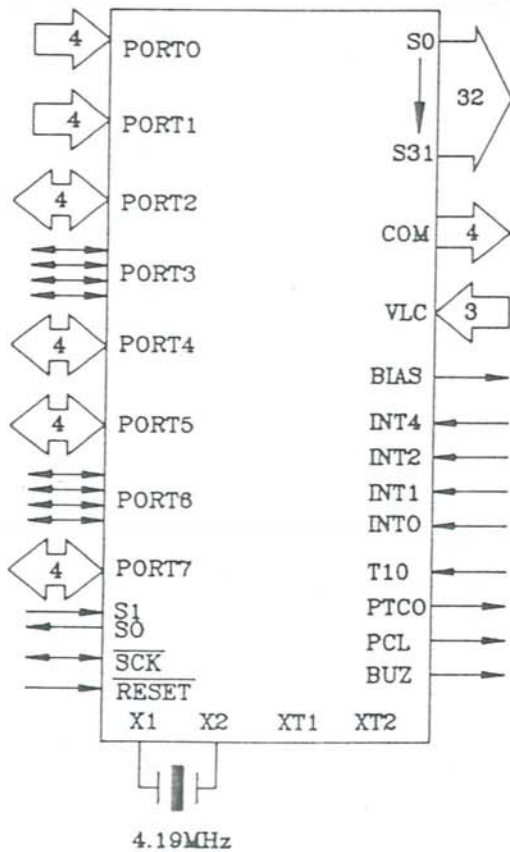

(Top View)

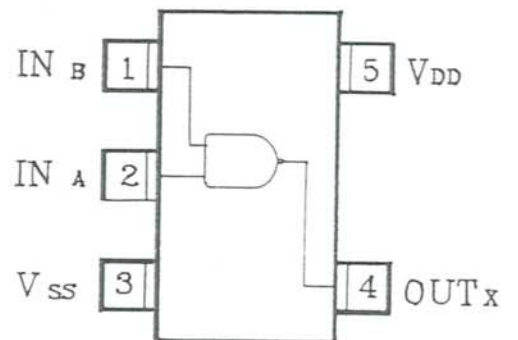

BLOCK DIAGRAM

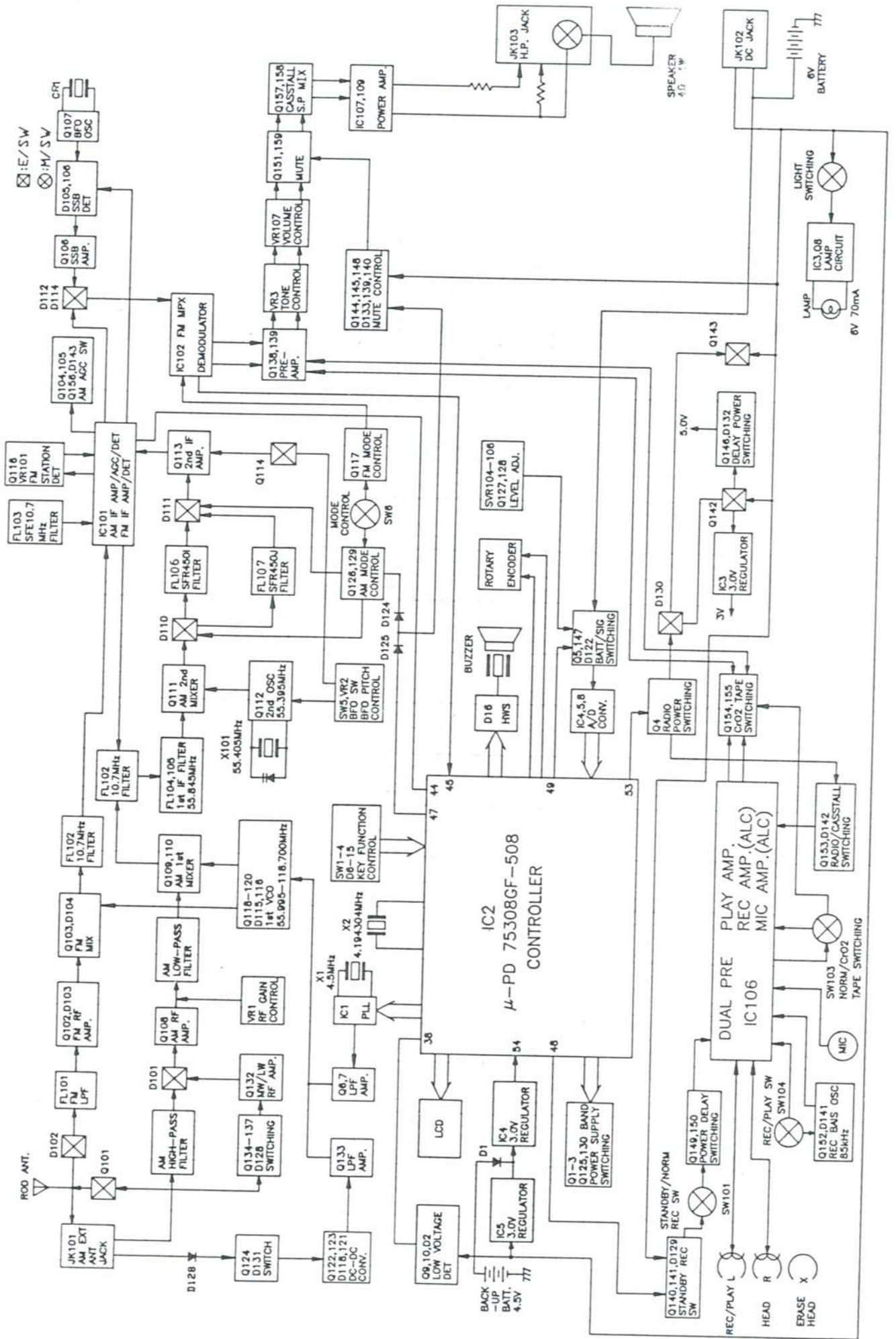

SCHEMATIC DIAGRAM

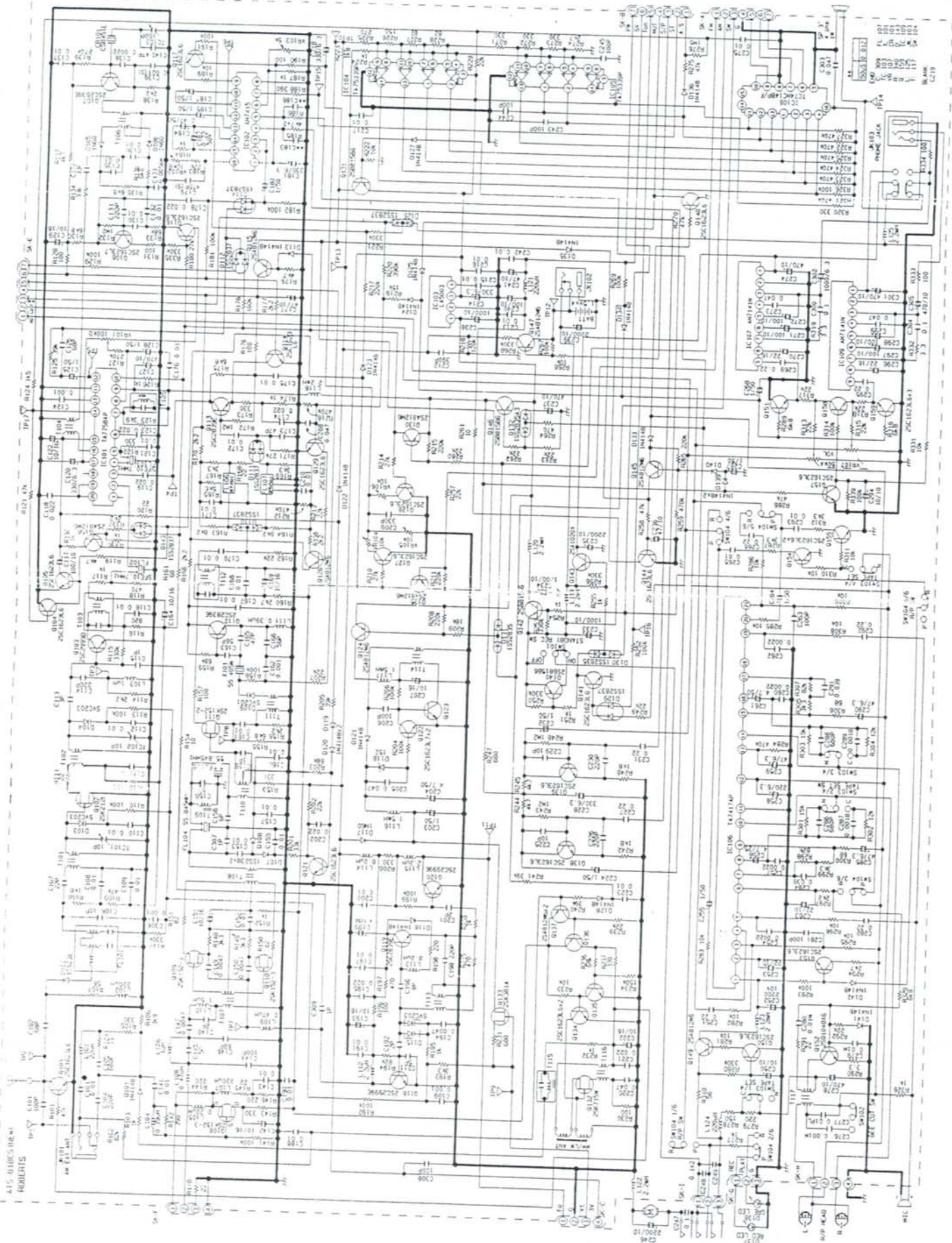

415 RUBENSTEIN
ROBERTS

81.7 29 83.9.5
81.9 15 83.10.3
83.3 8
83.12.13