

<ART-076-0>

# **SERVICE MANUAL**

STEREO TAPE DECK

# **RT-1011L**

KU, FV

<74G02Y31K>

 **PIONEER®**





## CONTENTS

1. SPECIFICATIONS .....	3	8.7 Erase Head Dummy Adjustment .....	25
2. PARTS IDENTIFICATION .....	5	8.8 Level Meter Calibration .....	25
3. CIRCUIT DESCRIPTIONS		8.9 Recording Sensitivity Adjustment .....	25
3.1 Playback Circuit .....	7	8.10 Rec. and P.B. Frequency Response Adjustment .....	26
3.2 Recording Circuit .....	7	9. SELECTION OF FREQUENCY AND VOLTAGE for FV model	
3.3 Oscillator Circuit .....	8	9.1 Selection of Line Frequency for FV model .....	27
3.4 Control Circuit .....	8	9.2 Switching Line Voltage Setting And Fuse (FV model) .....	27
3.5 Pause Circuit .....	11	10. SCHEMATIC DIAGRAMS, P.C. BOARD PATTERNS	
3.6 Function Buttons Release Circuit .....	11	AND PARTS LISTS	
4. DISASSEMBLY		10.1 Connection Diagram (Amplifier) .....	29
4.1 Back Covers .....	12	10.2 Schematic Diagram (Amplifier) .....	31
4.2 Side Boards .....	12	10.3 Connection Diagram (Control) .....	33
4.3 Amplifier Panel .....	13	10.4 Schematic Diagram (Control) .....	34
4.4 Mechanical Panel .....	13	10.5 Electric Parts .....	35
5. TROUBLE SHOOTING		10.6 P.B. Amplifier Assembly (RWF-028) .....	36
5.1 Transport Mechanism and Control System (1) .....	14	10.7 REC. Amplifier Assembly (RWF-029) .....	40
5.2 Transport Mechanism and Control System (2) .....	15	10.8 Control Assembly (RWG-046) for FV model .....	46
5.3 Electronic Circuit Trouble .....	17	10.9 Control Assembly (RWG-047) for KU model .....	50
6. MECHANICAL ADJUSTMENTS		10.10 Switch Circuit Assembly (RWS-024) .....	54
6.1 Reel Base Height Adjustments .....	20	10.11 EQ. Switch Circuit Assembly (RWS-027) for FV model .....	57
6.2 Brake Adjustment .....	20	10.12 EQ. Switch Circuit Assembly (RWS-026) for KU model .....	58
6.3 Take-up and Back Tension Torque Adjustment .....	21	10.13 OSC. Assembly (RWA-021) .....	60
6.4 Pinch Roller Pressure Adjustment .....	22	10.14 Fuse P.C. Board Assembly (RWX-061) .....	65
7. TAPE HEAD ADJUSTMENTS		10.15 REC. Lamp P.C. Board Assembly (RWX-058) .....	65
7.1 Course Adjustments .....	23	10.16 Shut-off Switch P.C. Board Assembly (RWX-047) .....	66
7.2 P.B. Head Adjustment .....	23	10.17 Motor Fuse Board Assembly (RWX-048) .....	66
7.3 Rec Head Adjustment .....	23	11. EXPLODED VIEWS AND PARTS LISTS	
8. CIRCUIT ADJUSTMENTS		11.1 Panel and Back Cover .....	67
8.1 Playback Sensitivity Adjustment .....	24	11.2 Mechanism (Drive Motor, Head) .....	71
8.2 Playback Equalizer Adjustment .....	24	11.3 Mechanism (Amplifier Assembly) .....	75
8.3 Playback Frequency Response Confirmation .....	24	11.4 Mechanism (Reel Motor) .....	79
8.4 Bias Oscillator Amplitude Adjustment .....	25	11.5 Packing .....	82
8.5 Bias-trap Adjustment .....	25	12. LEVEL DIAGRAMS .....	85
8.6 Recording Bias Adjustment .....	25		

## 1. SPECIFICATIONS

Drive System	3-motor drive system
Operation System	Solenoid-operated direct-changeable function buttons, Push-lock, pre-set function buttons for timer recording and playback
Tape Heads	4-track, 2-channel erasing head x 1 4-track, 2-channel recording head x 1 4-track, 2-channel playback head x 1
Motors	4/8-pole 2-speed hysteresis synchronous motor (For capstan drive) x 1 6-pole inner-rotor special induction motor (For reel drive) x 2
Tape Speeds	19 cm/s. (7-1/2 ips) and 9.5 cm/s. (3-3/4 ips) Speed tolerance: $\pm 1\%$
Fast Winding Time	Approximately 110 seconds (10-1/2 inch reel, 740m) Approximately 90 seconds (7 inch reel, 370m)
Wow and Flutter	Less than 0.08%, WRMS (0.10%, RMS at 19 cm/s., 7-1/2 ips) Less than 0.10%, WRMS (0.13%, RMS at 9.5 cm/s., 3-3/4 ips)
Signal-to-Noise Ratio	More than 55 dB
Total Harmonic Distortion	Less than 1%
Frequency Response	40~20,000 Hz, $\pm 3$ dB (at 19 cm/s., 7-1/2 ips) 40~12,000 Hz, $\pm 3$ dB (at 9.5 cm/s., 3-3/4 ips)
Crosstalk	More than 60 dB
Stereo Channel Separation	More than 50 dB
Erasing Coefficient	More than 60 dB
Bias Frequency	125 kHz
Equalizer	NAB standard
Inputs	
(Input sensitivity/Maximum input level/Input impedance)	LINE: 50 mV/25 V/100 k $\Omega$ (pin jack) MIC: 0.25 mV/80 mV/20 k $\Omega$ (1/4 in. 6.3 mm $\phi$ jack) REC & PB: 15 mV/1.5 V/1.5 k $\Omega$ (DIN standard jack)
Outputs	
(Reference level/Load impedance)	LINE: 316 mV/50 k $\Omega$ (pin jack) HEADPHONE: 40 mV/4~16 $\Omega$ (6.3 mm $\phi$ stereo jack)
Semiconductors	Transistors: 32 (including 2 FETs and 2 ICs) Diodes: 46 (including light emitting diode and 3 zener diodes)

Subfunctions	Tape Selectors (switchable 2-step recording bias selector, switchable 2-step recording equalizer selector) Pause lever (locking, also used as lag canceller) Recording Mode Switches (L, R) Tape monitor switch One-touch Reel Crampers LINE & MIC recording level control LINE/MIC (DIN) Mixing 4-digit tape counter Output Level Controls
Power requirements	
(FV model)	110, 120, 130, 220, 240 V (switchable) 50 or 60 Hz
Power requirements	
(KU model)	120 V 60 Hz
Power Consumption	
(FV model)	115 W
Power Consumption	
(KU model)	115 W
Dimensions (overall)	Without package: 428(W) x 431(H) x 227(D) mm 16-7/8(W) x 17(H) x 8-15/16(D) in. With package: 573(W) x 540(H) x 325(D) mm 22-5/8(W) x 22-1/4(H) x 12-13/16(D) in.
Weight	Without package: 18.6 kg/41 lb With package: 22.4 kg/49 lb 4oz
Accessories	10-1/2 inch metal reel x 1 10-1/2 inch reel adaptor x 2 Reel adjusting sheet x 2 Connection cords (stereo) x 2 Head cleaning kit x 1 Splicing tape x 1 Fuse (2A) x 1 Operating instructions x 1

- NOTES:
- Reference tape speed: 19 cm/sec. (7-1/2 ips)
  - Reference signal: 1 kHz
  - Reference recording level: meter 0 dB level (=210 pwb/mm)
  - S/N ratio is measured at +6 dB level from reference level (THD: less than 2.5%)
  - Frequency response is measured at -20 dB level from reference level
  - Input sensitivity: Required input signal level to produce reference output level
  - Reference output level: Reproduced output signal level at meter 0 dB level
  - Specifications and design subject to possible modification without notice due to improvements.

2. PARTS IDENTIFICATION

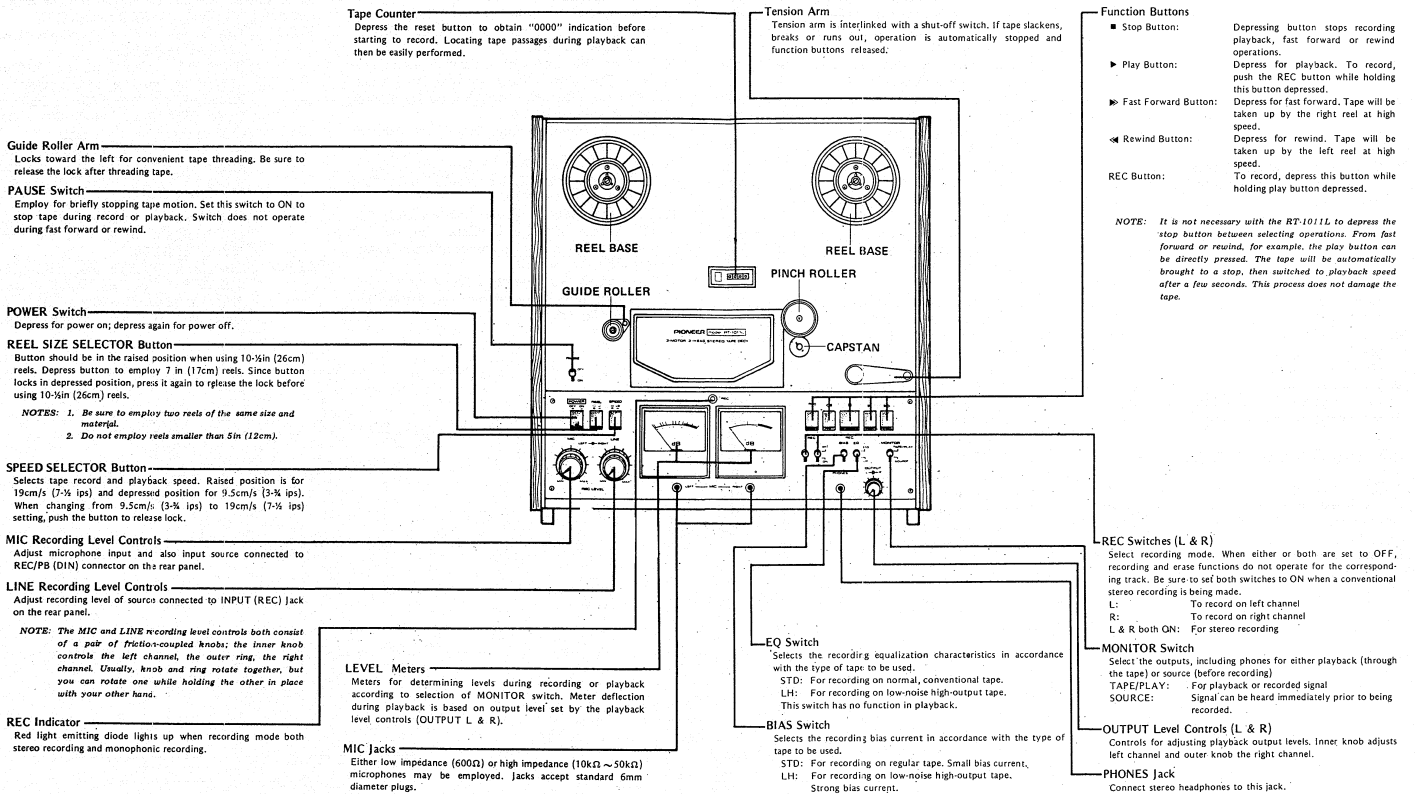

### 3. CIRCUIT DESCRIPTION

The RT-1011L tape deck contains 2-channel recording and playback. It employs two playback circuits, two recording circuits and one oscillator circuit. The left-channel major circuitry is shown in Fig. 1.

#### 3.1 PLAYBACK CIRCUIT (Fig. 1)

1. The signal received by the playback head is amplified via the three-stage direct coupled amplifier consisting of Q201, Q203, and Q205.
2. The playback signals flat frequency response is obtained by negative feedback from the Q205's collector to Q201's emitter through equalizer elements R221, C217, VR201, R223, and Q207.
3. Playback characteristics can be adjusted to two different tape speeds by utilizing the internal resistance of FET (Q207) which varies according to its gate voltage (0.6V for 7-1/2ips, -10V for 3-3/4ips).
4. The signal from Q205 is fed to VR5 and the playback output is provided at the LINE OUTPUT terminals.
5. The signal from VR5 is fed to IC401 and this provides the HEADPHONE output, as indicated on the level meter.

#### 3.2 RECORDING CIRCUIT (Fig. 2)

1. The input signal from the MIC input jack is amplified via C103 by the two-stage direct coupled amplifier consisting of Q101 and Q103.
2. The output from Q103 is fed to Q105 via

MIC recording level control (VR1) is established. Then the input signal from the INPUT terminal (LINE) is fed to Q105 through the LINE recording level control (VR3). When mixing recording with MIC and LINE, therefore, levels can be adjusted independently.

3. The signal amplified by Q105 and Q107 is fed to Q109's base via VR101.
4. In Q109, Q111, the signal is amplified, supplying the signal current which is required at the recording head. In addition, negative feedback from the Q111's collector is fed to Q109's emitter to compensate for low frequency sounds range via R153, C131 R155 (approx. +5dB at 20Hz).
5. In the high frequency sounds range, where compensation is made according to tape speeds, a switching circuit using diodes is used. Assuming that LH tape is used at 7-1/2 ips (19cm/s), D101 and D103 are biased plus into causing current to flow, and the series resonance circuit using L101 and C141 is activated.
6. The signal from the Q111 is fed to the recording head through L401 and C420. These are tuned in the oscillator frequency to prevent bias leakage through the Q111, Q109 circuit.
7. When operating the REC switches voltage +B is fed to the oscillator circuit and the current flows simultaneously to the light-emitting diode (D001) through the relays and recording is indicated (Fig. 3).

#### 3.3 OSCILLATOR CIRCUIT (Fig. 3)

1. When a voltage, approx. 39V, is supplied to Q404 and Q405, the oscillator, is activated by the positive feedback through the oscillator transformer (T401).
2. The oscillator output is supplied to the recording and erase heads through T401's secondary winding.
3. Part of the oscillator output is extracted from T401's secondary winding tap through R420 and C424, and rectified by D405 and D406 to feed VR403.
4. The DC voltage from VR403 is fed to Q403's base.
5. Q402 and Q403 from a regulator circuit. The +B power is supplied to Q404 and Q405 through Q402's emitter.
6. The DC voltage at Q403's base controls the +B voltage supplies oscillator circuit via regulator Q402. In this way oscillator output is regulated constantly.
7. The switch S3 functions for a variety of recording tape bias currents, and the switch S8-4 for tape speeds.

#### 3.4 CONTROL CIRCUIT (Fig. 4)

Three relays are used in the control circuit (RL601, RL602, RL603) and they operate as follows:

(In this description STOP means that the tape is not running with the POWER switch ON.)

RL601: This works for FAST FORWARD, REWIND and STOP.

When F.F. or REW button (S10 or S11) is pressed, the base of Q604 is biased via R607 ~ R606 ~ D606 ~ S10-2 (S11-2) to switch Q604 ON causing the relay to operate.

At STOP the base of Q604 is also biased via R608 ~ S12-1 ~ S11-2 ~ S10-2 to switch Q604 ON causing relay RL601 to operate.

The circuit of pinch solenoid (SL3) and RL602 is opened by the relay contact of RL601.

RL602: Operates at PLAYBACK AND RECORDING. When the PLAY button (S12) is pressed, S10 and S11 are switched off and current flows

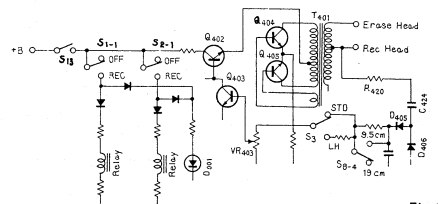

Fig. 3

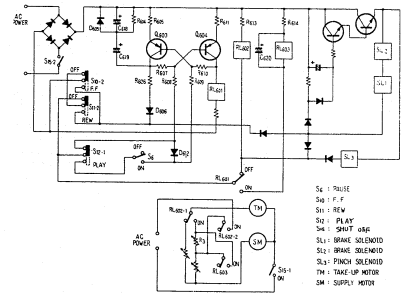

Fig. 4

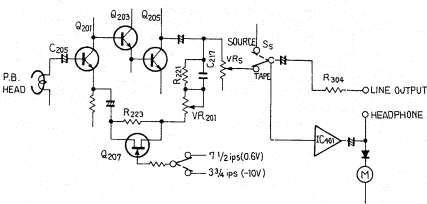

Fig. 1

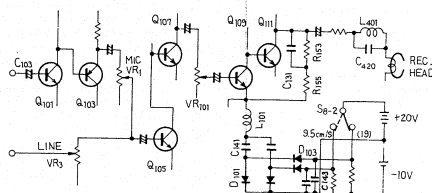

Fig. 2

through R613 ~ RL602 ~ relay contact RL601 ~ S11-2 ~ S10-2. This causes RL602 to operate.

Two motors T.M and S.M are energized through the contacts RL602-1 and RL602-2 of RL602 to give take-up torque and back tension.

RL603: Operates at FAST FORWARD, REWIND and STOP.

When the shut-off switch (S15) is ON at STOP, current flows through R614 ~ RL603 ~ relay contact RL601 ~ S11-2 ~ S10-2, causing RL603 to operate. The series resistance R3 of T.M is short-circuited by the contact of RL603.

● Control Circuit for Solenoid Supply Voltage (Fig. 5)

This circuit operates to prevent overheating from continuous operation of the solenoid, thereby dropping the current to that required to hold it ON. In Fig. 5, Q1, Q602, and ZD601 from a voltage stabilization circuit supplying the retaining current for continuous operation of the brake solenoids (SL1, SL2) and the pinch roller solenoid (SL3).

When the PLAY button is pressed, S12 changes over to the PALY position, and a closed loop is formed by the power supply (+) ~ Q1 ~ (SL3 ~ D610) / (SL2 ~ SL1 ~ D609) ~ relay contacts (RL601) ~ S11-2 (REW button) S10-2 (F.F. button) ~ power supply (-).

Q1 and Q602 are Darlington connected, and between the base and collector of Q602 is capacitor C621.

Immediately after the PLAY button is pushed, much charging current flows rapidly into C621 via power supply voltage(+) ~ C621 ~ R616 ~ Q602 in that order, and then the current that flows into Q1 increases, causing the solenoids to operate.

When C621 is completely charged, Q602 bias becomes constant by R615 and ZD601 and the current that flows into Q1 decreases into holding the continuous operation of solenoids ON.

- power supply to RL603 is cut off, and current flows to RL602.
- Even after the current has been cut off, RL603 continues to hold on briefly by means of the charge on C620 in parallel with it before releasing.
- This ensures that when the take-up motor is switched on, the series resistor (R3) remains ineffective, increasing the initial torque.

As soon as RL603 releasing the current flows through R3, and the torque Drops to the normal level.

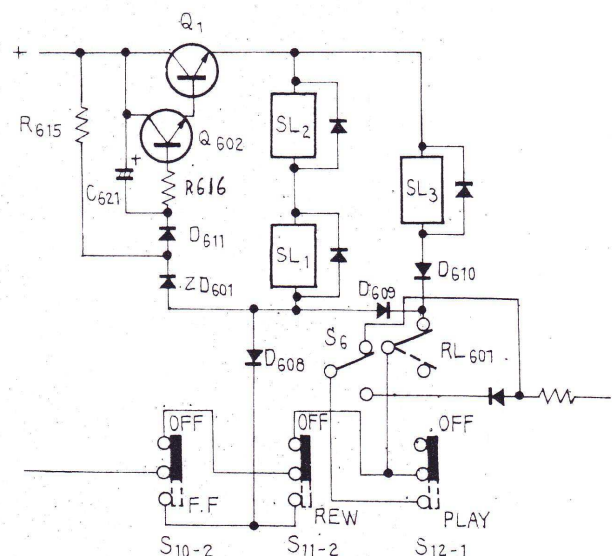

Fig. 5

● Take-up Torque Control in PLAYBACK (Fig. 6, 7)

In order to prevent tape slackening or hunting when switching form the STOP mode to PLAYBACK, the take-up torque is subject to initially reinforcement.

- When the tape deck is in the STOP mode (that is with no function button depressed). relay RL603 is operative, and the relay contacts short-circuit the series resistor (R3) of the take-up motor (T.M). Please refer to "Relay operation."
- When the PLAY button is depressed, S12-1 goes over to PLAY, the current from the

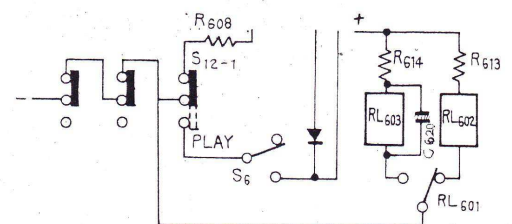

Fig. 6

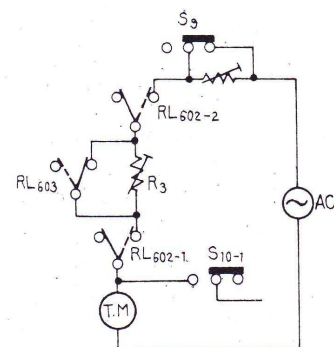

Fig. 7



● **Tape Protection at PLAYBACK Immediately From F.F. (or REW) (Fig. 8)**

If the PLAY button is pressed while the deck is in the FAST FORWARD (or REWIND) mode, the tape is brought to a halt briefly before resuming travel at the specified speed, in order to protect it.

As shown by Fig. 8, the circuit is structured mainly around Q603 and Q604.

1. The base of Q604 is biased via R607 ~ R606 ~ D606 ~ S10-2 (S11-2) while the deck is in the FAST FORWARD (or REWIND) mode. Q604 is thus ON and relay RL601 is operative.
2. The base of Q603 is connected via R610 to the collector of Q604. When Q604 is ON, the base of Q603 is reverse biased, and Q603 is OFF.
3. C619 is charged via R604 (C618) ~ C619 ~ R606 ~ D606 ~ S10-2 (S11-2).
4. When the PLAY button is pressed, S12-1 goes over to PLAY, S10-2 (S11-2) return to their OFF positions, and the base bias loop for Q604 (in step 1. above) is broken. The charge accumulated in C619, however, forms the base current of Q604 and keeps it on maintaining the relay RL601 operative.
5. Even if S12-1 goes over to PLAY, while the relay RL601 is operative, its relay contacts (RL601) will not cause RL602 to operate.
6. As C619 discharges, so the base current of Q604 drops, with a corresponding increase in its internal resistance, and a greater potential difference between the emitter and collector.
7. When this potential difference reaches 3V, the reverse bias which had been applied to Q603 becomes direct bias, and Q603 comes ON.
8. When Q603 comes ON, C619 is rapidly discharged via D605 ~ R605 ~ Q603, Q604 goes OFF, and the relay RL601 releases.

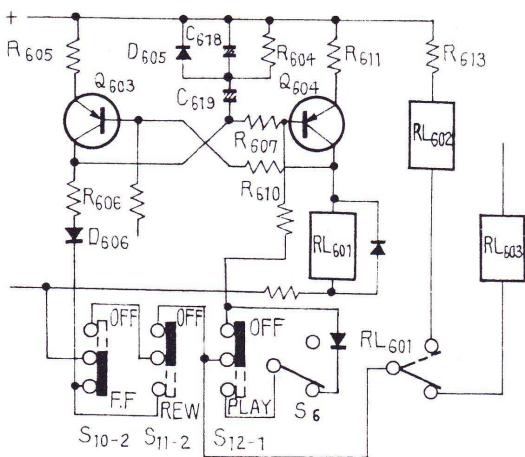

Fig. 8

9. As soon as relay RL601 releases, a current flows through R613 ~ RL602 ~ relay contacts (RL601) ~ S11-2 ~ S10-2, causing relay RL602 to operate so that the tape commences to travel at the specified speed.
10. C619 is fully charged after some 6 seconds of FAST FORWARD (or rewind), and it takes about 6 or 7 seconds after the PLAY button is pressed before the specified speed of tape travel commences.
11. R604 serves to delay the charging of C619 and D605 does to accelerate its discharge. If, therefore, the PLAY button is pressed after only from 0.5 to 6 seconds of FAST FORWARD or REWIND C619 will not be fully charged, the time taken for it to discharge (that is during which Q604 will remain ON), and the pause before the tape commences travel at the specified speed will be correspondingly shortened.

**The Function of C618**

Such delay circuit as shown in Fig 9 would not protect the tape on those occasions when the length of FAST FORWARD (or REWIND) operation is so short — 0.5 seconds or less — that the tape would not come to a complete halt before attempting to commence travel at the specified speed after pressing the PLAY button. If not prevented, this would cause the tape stretch or snap. This possibility arises because of the inadequate charge in C619 due to the very short time during which the tape deck is in the FAST FORWARD or REWIND mode. In order to prevent it the circuit shown in Fig. 10, incorporating C618 was added. The addition of C618 and R604 prevents the delay in the charging of C619 and provides sufficient voltage to hold Q604 ON instantaneously.

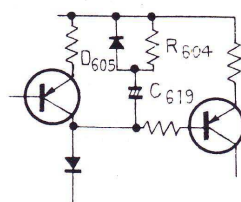

Fig. 9

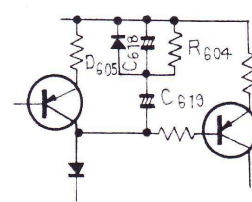

Fig. 10

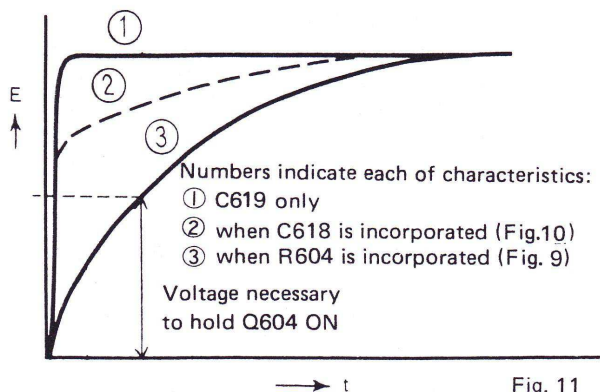

Fig. 11

### 3.5 PAUSE CIRCUIT (Fig. 12)

When the PAUSE switch (S6) is turned ON in the PLAY and REC modes, the base of Q604 is biased via R608 ~ D612 ~ S6 ~ S12-1 ~ S11-2 ~ S10-2 to switch Q604 ON, causing RL601 to operate. Because of this, the contact of RL601 is closed to operate RL603. This also makes solenoids SL1, SL2 and SL3 non-operative. Further, RL602 restored and, through its contacts (RL602-1, RL602-2), shuts off the power to T.M and S.M stopping these motors. When the PAUSE switch is turned OFF, the bias to Q604 is cut off and relay RL601 restores. Its contact is opened. But RL603 remains operative until C620 completes discharging, improving the take-up torque at the beginning of tape transport.

Reduction of waiting time lag by use of PAUSE switch. When the Fast Forward or Rewind modes continue for more than 6 seconds, C619 is charged. The deck needs 6 ~ 7 seconds to start playing when the PLAY button is pressed. This time lag can be shortened using the PAUSE switch.

1. Q604 is ON in the F.F. and REW modes.
2. The base of Q603 is connected to the collector of Q604 via R610. When Q604 is ON, Q603 is OFF.
3. C619 is charged via R604(C618) ~ C619 ~ R606 ~ D606 ~ S11-2 ~ S10-2.
4. When the PLAY button is pressed, C619 stops charging and discharges via C619 ~ D605 ~ R611 ~ Q604 ~ R607 to produce Q604's base bias current, keeping Q604 ON for several seconds.
5. When the PAUSE switch is ON, Q603 is forward biased to ON via R609 ~ S6 ~ S12-1 ~ S11-2 ~ S10-2 and, C619 is rapidly discharged through the loop C619 ~ D605 ~ R605 ~ Q603.

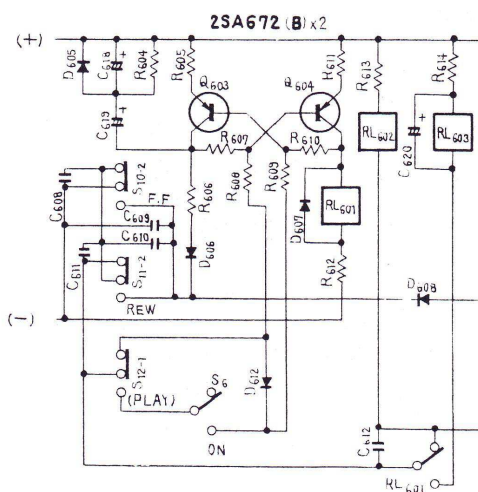

Fig. 12

6. When the PAUSE switch is OFF, the bias loop R608 ~ D612 ~ S6 ~ S12-1 ~ S11-2 ~ S10-2 is cut off to turn Q604 OFF. This restores RL601 and operates RL602, starting tape transport.

### 3.6 FUNCTION BUTTONS RELEASE CIRCUIT (Fig. 13)

When the tape has shut-off switch (S15) goes 'OFF', and solenoid SL601 operates to release the function button.

1. S15 goes ON when the tape is properly loaded, and feeds the AC supply to the circuit.
2. The base of Q601 is subject to reverse bias via D603 and Q601 is thus OFF, C617 is also charged via D604.
3. When the tape has been fully taken up and S15 goes OFF, no negative voltage from D603 comes supplied, and the charge accumulated on C617 positively biases Q601 via R603, so that Q601 goes ON, and C617 discharges via SL601 ~ Q601.
4. This discharge is the means by which the release solenoid operates, so releasing the function button which has been depressed.
5. This circuit, if S15 is ON will operate if the power supply is interrupted, and automatically release the function button.

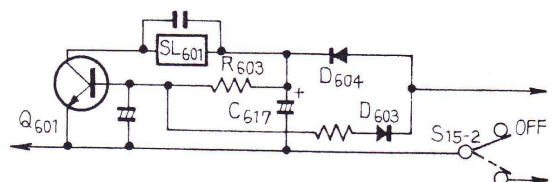

Fig. 13

### 3.7 TAPE SPEED SWITCHING-OVER

The capstan motor is a hysteresis synchronous type, operates at the main power supply frequency. Speed switching is effected by altering the number of poles by means of the SPEED SELECTOR switch S8

- 19 cm/s(7-1/2 ips.) . . . . . 4 poles
- 9.5cm/s(3-3/4 ips.) . . . . . 8 poles



## 4. DISASSEMBLY

### 4.1 BACK COVERS (Fig. 14)

1. Take out screws 1, 2, 5 and 7, but only loosen screws 3, 4 and 6. Remove the back cover (A).  
This exposes the internal mechanism and permits examination.
2. Take out screws 8 ~ 13 and remove back cover (B).  
The amplifiers can then be adjusted.

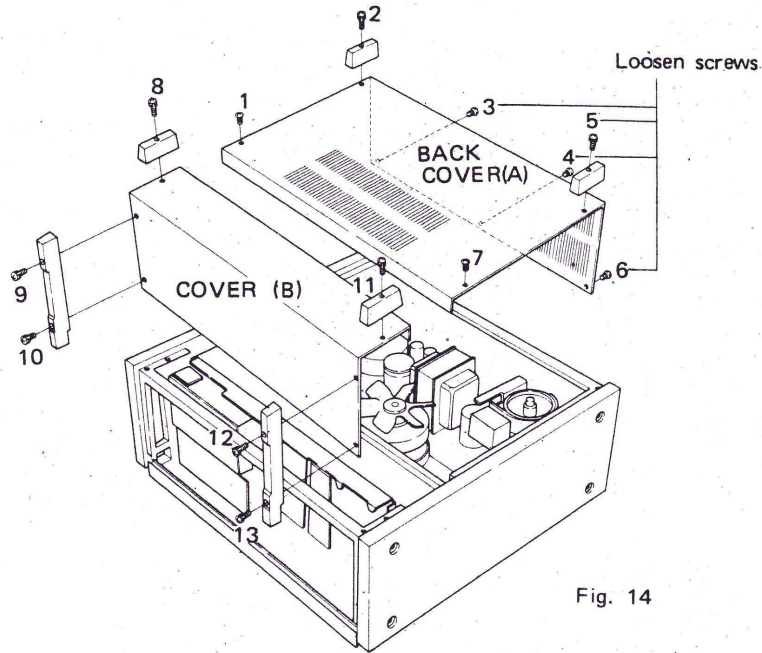

### 4.2 SIDE BOARDS (Fig. 15)

Take out screws 1 ~ 8 and remove the side-boards.

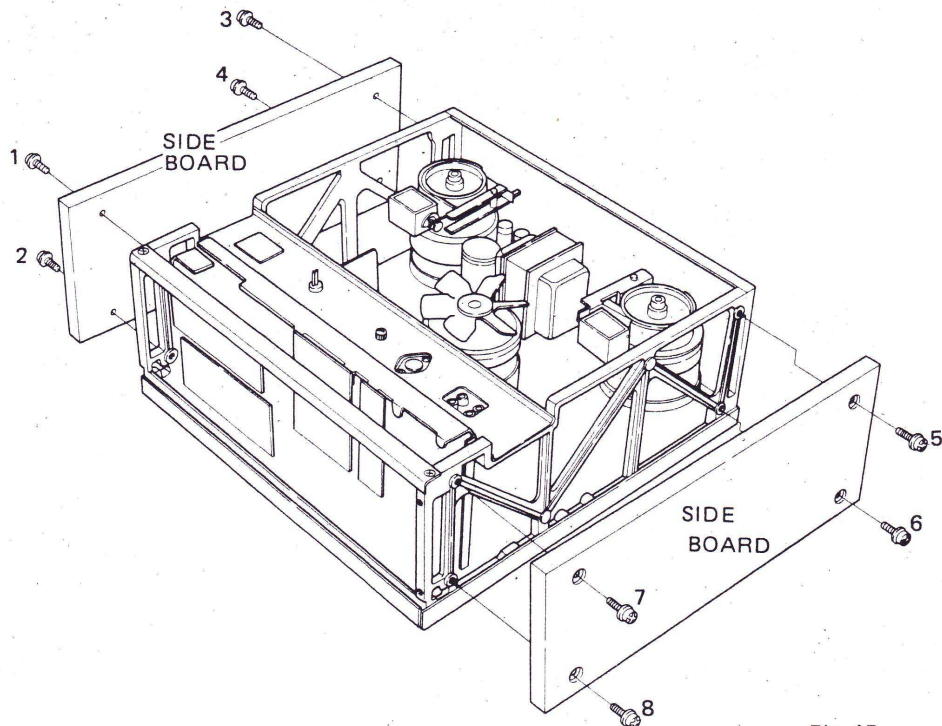

4.3 AMPLIFIER PANEL (Fig. 16)

1. Remove all knobs.
2. Take out screws 1 ~ 4 and remove the amplifier panel.  
The level meters can then be replaced.

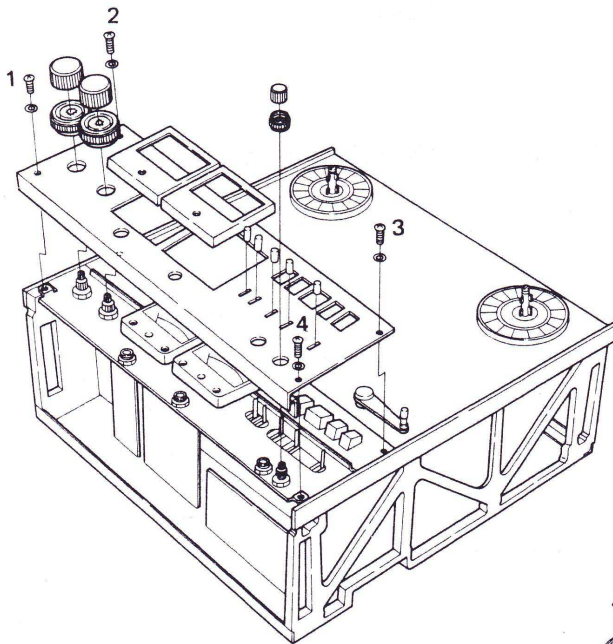

Fig. 16

4.4 MECHANICAL PANEL (Fig. 17)

1. Take out screws 1 ~ 2 and remove the head housing.
2. Take out screw 3 and remove pinch roller.
3. Take out screws 4 ~ 6 and remove the reel base.
4. Take out screws 7 ~ 9 and remove the guide roller.
5. Take out screw 10 and remove the tension arm.
6. Remove the PAUSE knob.
7. Take out screws 12 ~ 17 and remove the mechanical panel by lifting out the aluminum sashes.
8. Take out shaft cap.

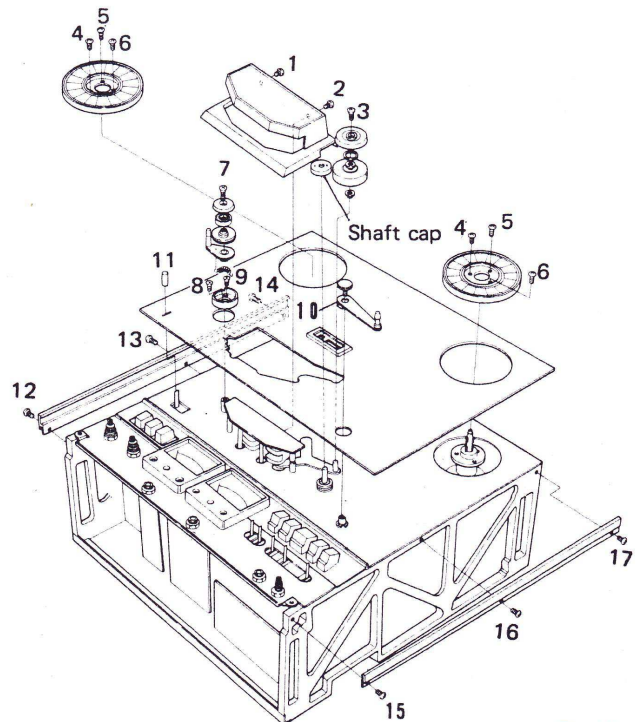

Fig. 17

## 5. TROUBLE SHOOTING

### 5.1 TRANSPORT MECHANISM AND CONTROL SYSTEM (1).

“Reel motor” refers to the take-up and supply motors. For further explanation, see section 5.2, Nos. 1 ~ 5.

#### ● Power supply and lamps.

Lack of Power ON. ————— See 5.2.1 “Power and lamps.”

Lamp does not light. ————— See 5.2.1 “Power and lamps.”

Control system does not function. ————  
    Burned-out fuse (F 5). ————— Replace.  
    Defective shut-off switch. ————— Replace.

#### ● Playback function.

Take-up too weak or too strong. ————  
    Improperly positioned REEL size switch. ————— Correct position to match reel size.  
    Trouble in reel motors. ————— See 5.2.2 “Reel motors.”

Insufficient tape speed. ————  
    Pinch roller slipping. ————— See 5.2.3 “Pinch roller.”  
    Poor pinch roller pressure. ————— See 5.2.3 “Pinch roller.”  
    Excessive back tension. ————— Re-adjust. See section 6.3.  
    Poor capstan motor torque. ————— See 5.2.4 “Capstan motor.”

Defective tape speed switching. ————  
    Defective switch (S 8). ————— Replace.

Wow and flutter. ————  
    Dust on pinch roller and capstan. ————— Clean with absolute alcohol.  
    Defective pinch roller. ————— See 5.2.3 “Pinch roller.”  
    Poor pinch roller pressure. ————— See 5.2.3 “Pinch roller.”  
    Excessive friction or sticking of flywheel bearing. ————— Lubricate, clean or replace where necessary.  
    Excessive back tension. ————— Re-adjust. See section 6.3.  
    Trouble in capstan motor. ————— See 5.2.4 “Capstan motor.”

(Take-up side)  
Tape slackens at start of tape travel. ————  
    Abnormal take-up torque. ————— See 5.2.2 “Reel motor.”  
    Relay RL603 released earlier. ————— Replace capacitor (C 620).  
    Poor back tension. ————— See 5.2.2 “Reel motor.”

(Supply side)

Tape squeals. ————  
    Soiled tape guide. ————— Clean with absolute alcohol.  
    Damaged tape. ————— Replace.



● Fast forward and rewind.

Take-up delayed until end of tape travel. — Poor take-up motor torque. — See 5.2.2 "Reel motors."  
 — Excessive back tension. — See 5.2.2 "Reel motors."

Tighten or loosen tape winding. — Abnormal back tension. — Re-adjust. See section 6.3

Tape slackens at stop of the tape. — Difference in sizes of right and left reels. — Match reel sizes properly.  
 — Brake timing trouble or mal-adjustment. — See 5.2.5 "Brake."

Mechanical noise during operation. — Defective reel motors. — Replace.  
 — Defective guide roller. — Replace.

Short interval-time between fast forward or rewind to play. — Defective capacitors (C618, C619) — Replace.

5.2 TRANSPORT MECHANISM AND CONTROL SYSTEM (2).

1. Power and lamps.

Lack of power input. — Burned-out fuse. — Replace.  
 — Defective AC cord. — Replace.  
 — Power switch failure. — Replace.  
 — Defective power transformer. — Replace.

Meter lamp does not light. — Defective lamp. — Replace.  
 — Burned-out fuse. — Replace.

**2. Reel motors** . . . . . Check to make sure line frequency switch is in proper position.

No voltage to motor. — Defective shut-off switch contact. — Replace.  
 — Burned-out fuse (F6 or F7) — Replace

Motor failure despite apparent voltage. — Defective phase capacitor. — Replace.  
 — Stuck motor shaft. — Replace the motor.  
 — Defective motor coil. — Replace the motor.  
 — Brake does not clearance. — Re-adjust. See section 6.2.

Defective take-up at playback mode. — Defective wire wound resistor (R 3 or R 4). — Replace.  
 — Defective relay contact or relay (RL 602). — Replace  
 — Imperfect FUNCTION button contact. — Replace.

No back tension in playback mode. — Defective wire wound resistor (R 2). — Replace.

Defective fast forward. — Excessive back tension. — Re-adjust. See section 6.3.  
 — FUNCTION button contact failure. — Replace.

Defective rewind. — Excessive back tension. — Re-adjust. See section 6.3.  
 — Poor FUNCTION button contact. — Replace.

No back tension in fast forward mode. — Defective wire wound resistor (R 1). — Replace.

**3. Pinch roller** . . . . . Also check solenoid (SL 3).

Revolving sound squeaks. — Stuck bearing. — Clean and lubricate.

Dull rotation. — Stuck bearing excessive friction. — Clean or replace bearing, then lubricate.

Pinch roller slipping. — Dirty pinch roller. — Clean with absolute alcohol.

Defective solenoid function. — Defective transistors (Q1, Q602). — Replace.  
 — Defective diode (D610). — Replace.

OK

Insufficient attracting force. — Imperfect solenoid installation. — Re-adjust. See section 6.4.  
 — Defective control circuit. — Check circuit and make necessary repairs.  
 — Worn-out solenoid shaft — Replace the solenoid

**4. Capstan motor . . . . .** Check to see that line frequency switch is properly positioned.

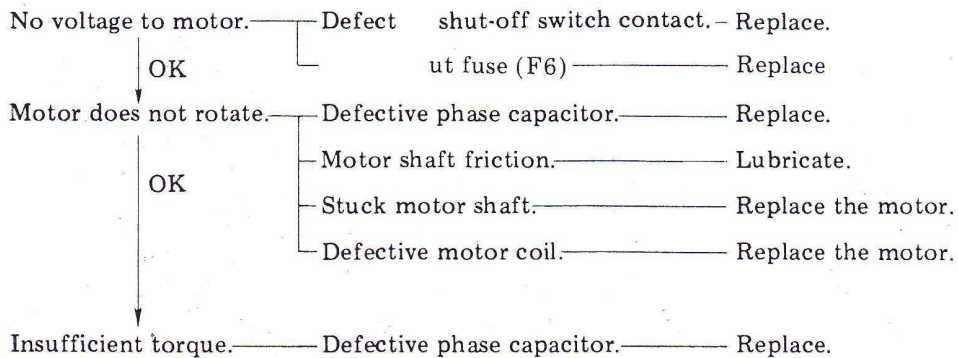

**5. Brake . . . . .** Also check brake solenoids (SL1, SL2).

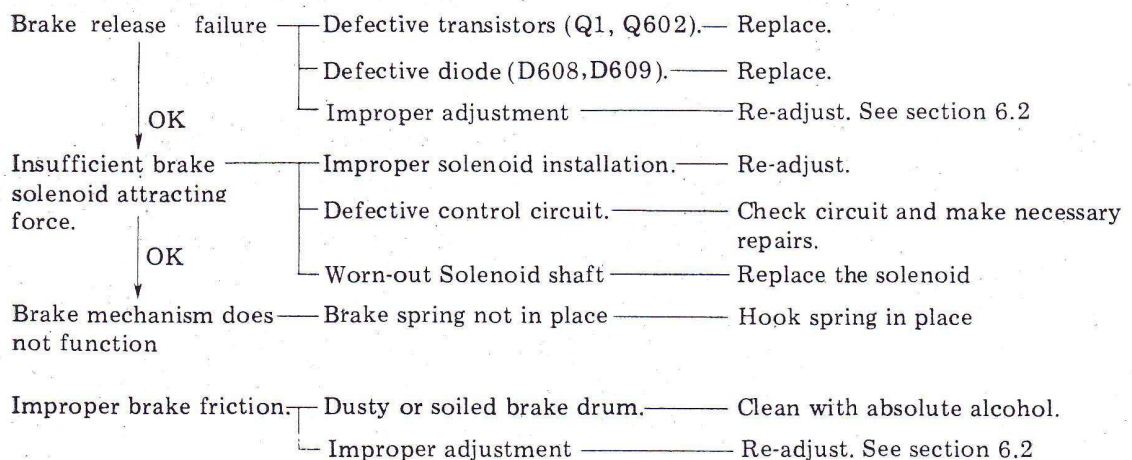

**6. Function button.**

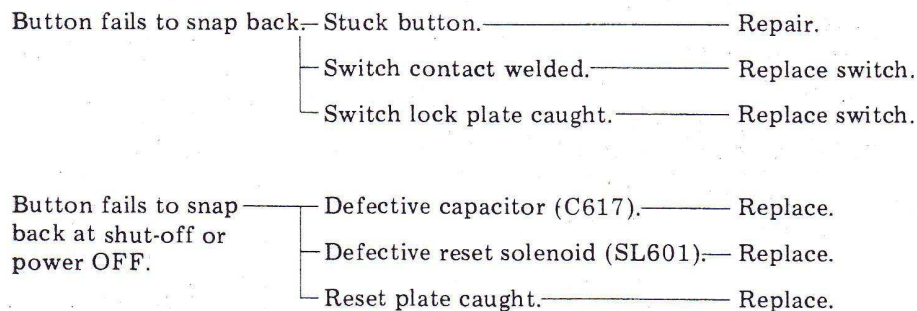

**5.3 ELECTRONIC CIRCUIT TROUBLE**

● **No playback sound.**

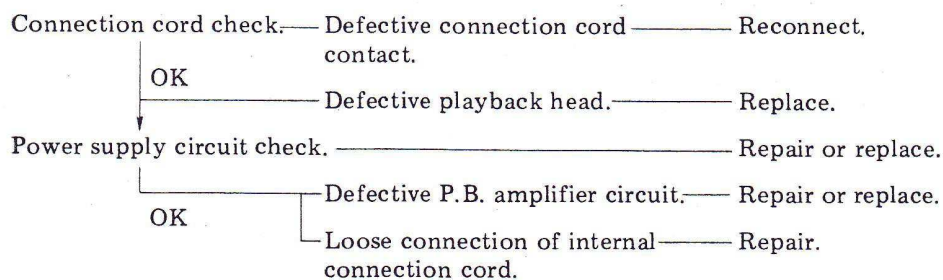









## 6. MECHANICAL ADJUSTMENTS

For items 6.1 ~ 6.4 adjustments, never fail to place the tape deck in specified positions (6.1: horizontal, 6.2 ~ 6.4: vertical), otherwise, correct measuring value would not be obtained. With these things in mind, proceed as follows:

### 6.1 REEL BASE HEIGHT ADJUSTMENT

In the case of incorrect reel base height, or replacement of supply motor or take-up motor, sideboards are removed and reel base height must be adjusted.

1. Place the tape deck in a horizontal position and check to make sure the panel and chassis of the transport mechanism are firmly attached.
2. Loosen screw to allow a clearance of 8.5mm between the mech panel and reel base as in Fig. 18.
3. Adjust supply and take-up reel bases as above.

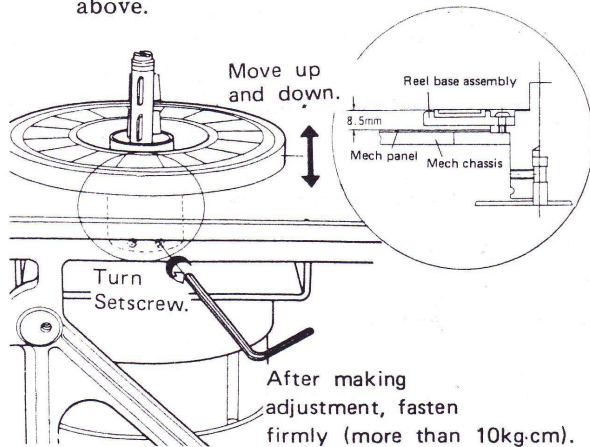

Fig. 18

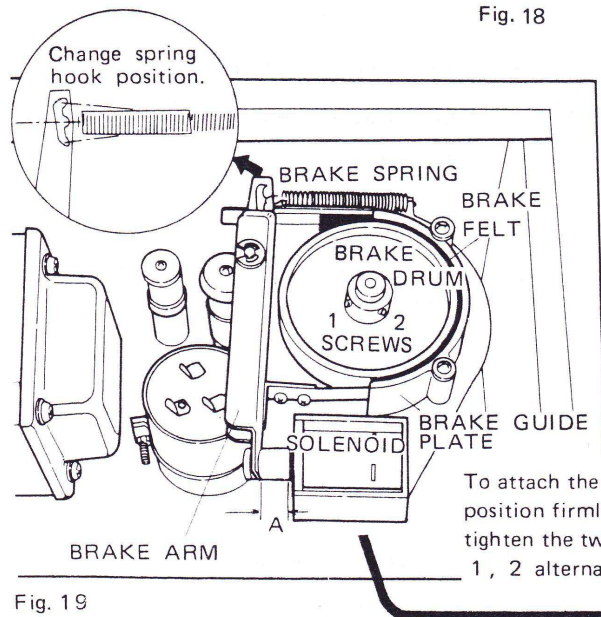

Fig. 19

### 6.2 BRAKE ADJUSTMENT

Required when tape slackens or when solenoid or motor is replaced.

First, place the tape deck in a vertical position and check the following:

- Is A in Fig. 19 12.8mm when the solenoid is not operating?
- Can you rotate the motor smoothly with your hand while pressing the solenoid shaft?

#### ● Adjustment (Figs. 19, 20)

For adjusting the take-up reel, fast-forward it for about 2sec. once to minimize unstableness in measuring values, then push the STOP button to cause reel revolution to halt.

Should the reel be rotated before measuring, differences in measuring values would result. For adjusting the Supply reel, rewind it once, then make the adjustment.

These adjustments are made in (A) ~ (D) arrow-indicated directions.

With these things in mind, proceed as follows:

1. Load the 7-inch reel, fixing the string on the reel base.
2. Pull tension gauge to measure brake friction, pulling in B (C) direction until reel turns.
3. Adjust the brake spring hook position so that the gauge reads 300 ~ 450g (900 ~ 1350g-cm).
4. When the above adjustments fail to bring the desired results, check the following points:
  - Soiled brake drum
  - Soiled brake felt
  - Faulty brake guide plate
  - Unstable brake arm
5. Measure brake friction by pulling tension gauge in D (A) direction. Then, check ratio of brake friction to measured value of step 3. It should be 2.3:1 ~ 3.7:1.

#### NOTE:

When the value in B (C) direction indicates 400g, the value in D (A) direction is optimum at a range of 174 ~ 108g.

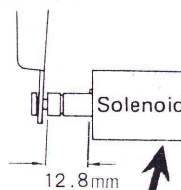

● Confirmation After Adjustment

1. When the prior adjustment is over, lower 10% power source voltage (down to 108V in 120V area, for example) in order to check up on fast-forward or rewind operation with the help of a 10-inch metal reel (long tape 150%).
2. While transporting the tape reels at high speed, push the PLAY button when the tape volume being now taken up in the take-up reel becomes increased more than that of the supply reel — when you see the taken-up volume show about 10 ~ 40 m/m
3. Confirm that the tape speed runs normal after it stops completely.
4. If the specified condition in step 3 is found unsatisfactory, try to satisfy step 3 repeatedly even though a tension gauge does not read less than 300g·cm.

NOTE: C618 and C619 short of capacitance make condition in step 3 unsatisfactory.

6.3 TAKE-UP AND BACK TENSION TORQUE ADJUSTMENT

● Back Tension Torque at Playback (Figs. 20,21)

1. Set REEL size switch at 10-inch reel position.
2. Set tape deck in vertical position in playback mode at 7-1/2 ips (19cm/s). Measure back tension of supply reel base by pulling tension gauge in B direction as shown in Fig. 20.

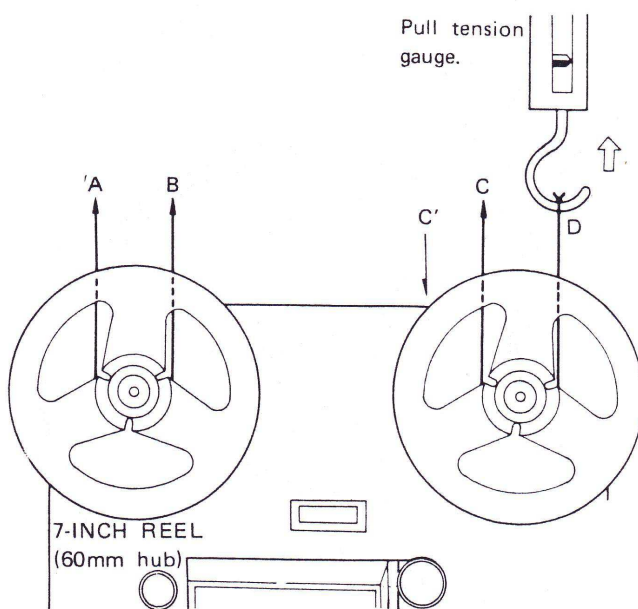

Fig. 20

3. Adjust slider ( $R_2$  500 $\Omega$ ) so that the gauge reads 93 ~ 110g (280 ~ 330g·cm) (Fig. 21).
4. Set REEL size switch at 7-inch reel position. Measure back tension as mentioned in step 2.
5. Adjust slider ( $R_4$  100 $\Omega$ ) so that the gauge reads 63 ~ 77g (190 ~ 230g·cm).
6. After adjustment, the slider screw must be firmly clamped.

● Take-up Torque at Playback (Figs. 20, 21)

1. Set REEL size switch at 10-inch reel position.
2. Set tape deck in vertical position and in playback mode at 7-1/2 ips (19cm/s). Measure take-up torque of take-up reel base (While moving tension gauge slowly in C' direction as shown in Fig.20, read value of the gauge.)
3. Adjust slider ( $R_3$  300 $\Omega$ ) so that the gauge reads 190 ~ 210g (570 ~ 630g·cm).

● Back Tension Torque at Fast Forward (Figs. 20,21)

1. Set reel size switch at 10 in. reel position.
2. Set tape deck in vertical position in fast forward mode. Measure back tension of supply reel base (pull in B direction as shown in Fig. 20).
3. Adjust the slider ( $R_1$  2k $\Omega$ ) so that the gauge reads 35 ~ 45g (105 ~ 135g·cm).

NOTE:

When back tension of fast forward is adjusted, back tension of rewind is determined automatically, since the resistor  $R_1$  is used for both functions.

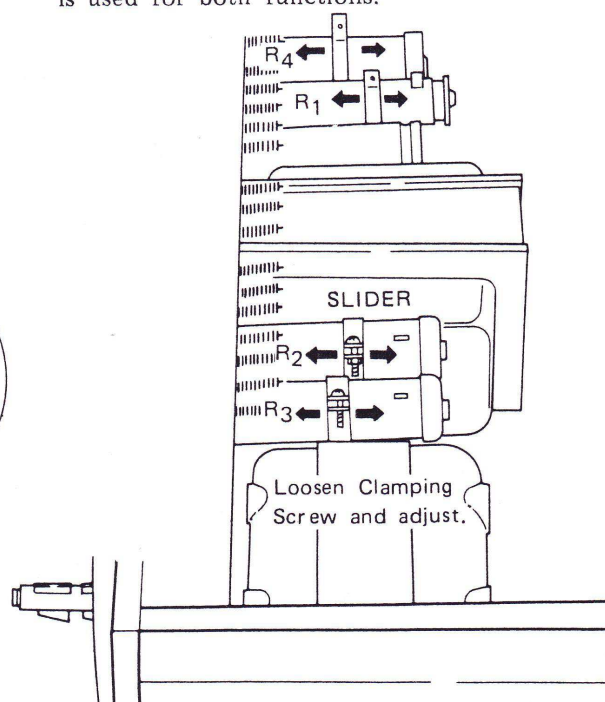

Fig. 21



## 6.4 PINCH ROLLER PRESSURE ADJUSTMENT (Figs. 22, 23)

When replacing pinch roller solenoid or pinch roller, check pressure of capstan as follows:

1. Set tape deck in vertical position with REEL size switch at 10-inch reel position.
2. Turn POWER switch and shut-off switch ON.  
Set deck in playback mode.
3. Make sure that the gap B shown in Fig. 22 is 1mm.
4. If the value is not correct, loosen the three bracket-held screws and adjust position of pinch roller solenoid.
5. Load Scotch No. 111, 10-inch metal reel (or similar product). Run tape fast forward until amount on take-up reel matches that on supply reel.
6. Play tape at constant speed (7-1/2 ips) hook tension gauge as in Fig. 23, then pull the gauge, and confirm the value when travel is stopped in 1.7kg ~ 2kg range.
7. When tape traveling is not stopped with in 1.7kg ~ 2kg, check the following:
  - Loosen pressure spring fastening
  - Defective pinch pressure spring
  - Soiled pinch roller
  - Soiled capstan

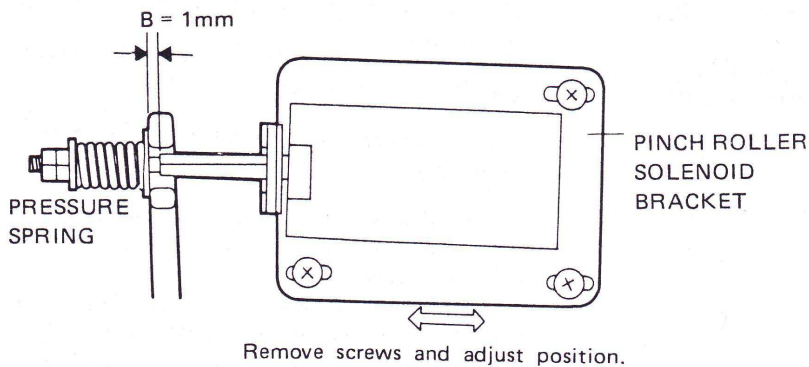

Fig. 22

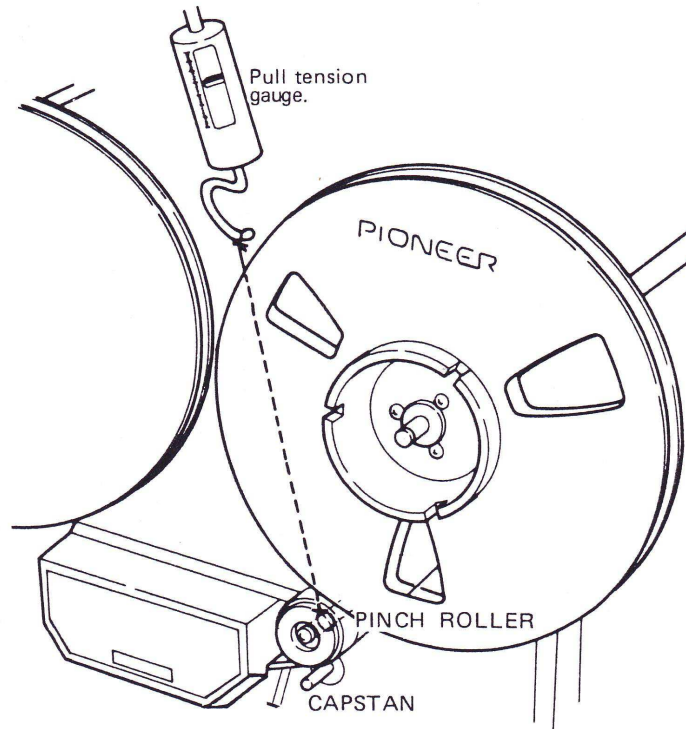

Fig. 23

## 7. TAPE HEAD ADJUSTMENTS

### 7.1 COURSE ADJUSTMENT (Figs. 24, 25)

#### ● Height

Adjust screws to proper relation dimension between tape and heads as shown in Fig. 24.

P.B. Head . . . . screws 1, 2, 3

REC Head . . . . screws 6, 7, 8

ERASE Head . . . Use spacer.

When adjusting the erase head, make sure contact with the tape surface is flat.

#### ● Tilt Angle

Adjust the following screws so that the head and tape touch evenly and flatly when tape is traveling.

P.B. Head . . . . screw 1

REC Head . . . . screw 6

#### ● Azimuth

Adjust the following screws so that the head gap and tape surface are touching vertically.

P.B. Head . . . . screw 3

REC Head . . . . screw 8

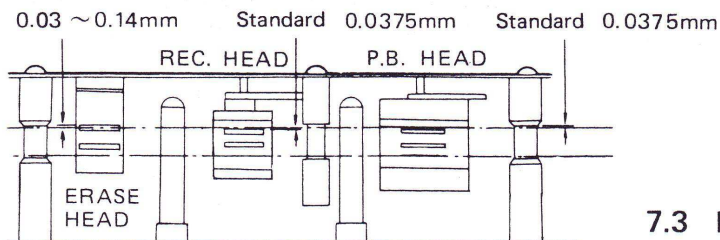

Fig. 24

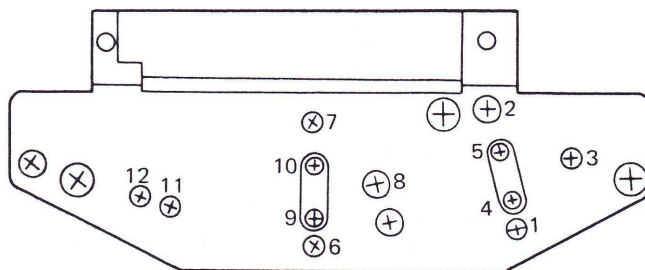

Fig. 25

### 7.2 P.B. HEAD ADJUSTMENT (Fig. 25)

1. Play the fifth band (15kHz, -10dB full track) of test tape at 7-1/2 ips (19cm/s).
2. Adjust the screw 3 for the maximum output level.  
A little output level difference between L- and R-channel is allowed in this adjustment.
3. During step 1, check to make sure the output level does not change, by pressing the tape slightly with your fingertip while it travels.
4. If the output levels change from step 3, screws 4 and 5 and adjust the head position by slightly moving it horizontally.

### 7.3 REC. HEAD ADJUSTMENT (Fig. 25)

1. Supply input signal of 500Hz, -10dBv (316mV) to the INPUT terminals.  
Load tape, then record above signal.
2. During recording, check playback level with MONITOR switch set to TAPE position.
3. Adjust the screws 6, 7 and 8 for the maximum playback level.
4. Set frequency to 15kHz and check playback output as above.  
Adjust screw 8 slightly for the maximum playback level.
5. During step 4, check to make sure that the output level does not vary, by pressing the tape slightly with your fingertip while it travels.
6. If output levels differ greatly, loosen the screws 9, 10 and adjust the head position by slightly moving the head horizontally.

# 8. CIRCUIT ADJUSTMENTS

The following measuring instruments are required for circuit adjustments:

- MILLI VOLTMETER
- AUDIO OSCILLATOR
- OSCILLOSCOPE
- ATTENUATOR
- FREQUENCY MEASURING INSTRUMENT (FREQUENCY COUNTER)
- AC VOLTMETER (With probe)

Controls are the tape deck as follows unless otherwise specified:

Tape speed	7-1/2 ips (19cm/s)
REEL size switch	7-inch reel
REC BIAS switch	STD
REC EQ switch	STD
REC switch	STEREO
OUTPUT level	OVU position

Reference voltage level for measurements 50kΩ resistor to the LINE OUTPUT terminals.

## 8.1 PLAYBACK SENSITIVITY ADJUSTMENT (Fig. 26)

1. Connect milli voltmeter to LINE OUTPUT terminal.
2. Play back the test tape, 700Hz, 0dB, full track.
3. Adjust the following P.B. level controls so that the voltmeter reads -10dBv (316mV).

## 8.2 PLAYBACK EQUALIZER ADJUSTMENT (Figs. 26, 27)

1. Connect milli voltmeter to LINE OUTPUT terminal.
2. Play back the test tape, 10kHz, -10dB, full track.
3. Adjust the following semi-fixed resistors so that the voltmeter reads -20dBv (100mV).  
 VR201 . . . . . L ch.  
 VR202 . . . . . R ch.
4. "PLAYBACK SENSITIVITY ADJUSTMENT" and "PLAYBACK EQUALIZER ADJUSTMENT" have related functions. Repeat these adjustments as several times as necessary.

## 8.3 PLAYBACK FREQUENCY RESPONSE CONFIRMATION

After the "PLAYBACK EQUALIZER ADJUSTMENT" is completed, play back the test tape recorded from 15kHz to 50Hz. Check the output response to make sure that it is made in the proper sequence following play back frequency response as shown in Fig. 27.

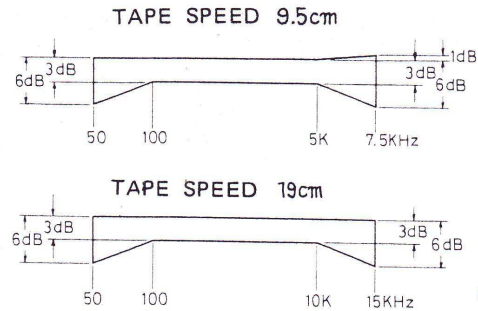

Fig. 27

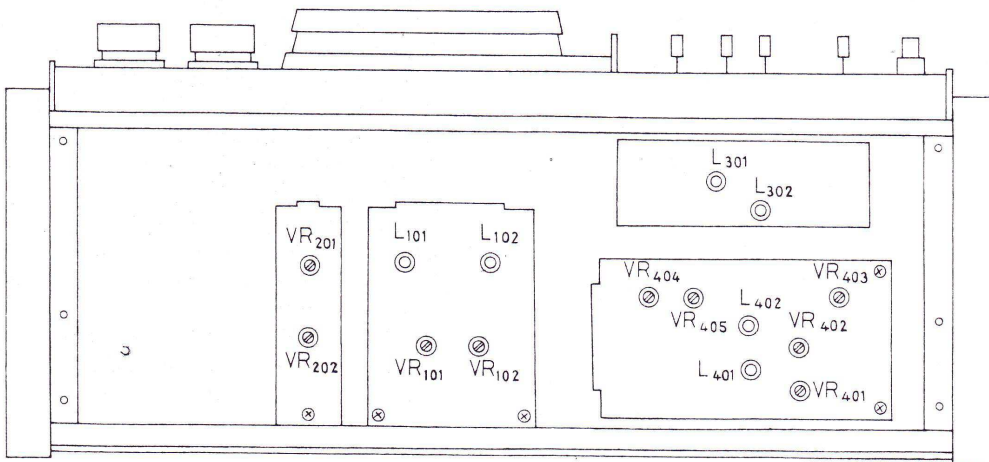

Fig. 26



#### 8.4 BIAS OSCILLATOR AMPLITUDE ADJUSTMENT (Fig. 26)

1. Connect AC voltmeter with probe to the test point (TP<sub>401</sub>) of OSC circuit P.C. board and ground.
2. Without loading tape, set tape deck in recording mode.
3. Adjust the VR<sub>403</sub> so that the oscillator voltage reads 22V.

**NOTE:**

Since the oscillator frequency is high (125kHz), handle the probe or connections carefully to avoid measurement errors.

#### 8.5 BIAS-TRAP ADJUSTMENT (Fig. 26)

1. Connect oscilloscope to terminals 18 and 19 at OSC circuit P.C. board and ground.
2. Without loading tape, set the tape deck in recording mode.
3. Adjust the L<sub>401</sub> (L ch.) and L<sub>402</sub> (R ch.) for the minimum amplitude on the oscilloscope (less than 1V<sub>p-p</sub>).

#### 8.6 RECORDING BIAS ADJUSTMENT (Fig. 26)

1. Connect milli voltmeter to LINE OUTPUT terminal. Apply the 1kHz, -10dBv (316mV) signal to INPUT terminal.
2. Record the signal on Scotch No. 111 tape and playback simultaneously. Control the LINE recording level control to obtain the output level of -10dBv at OUTPUT terminal.
3. Allow tape to travel for approx. 30 seconds. Adjust the semi-fixed resistors, VR<sub>401</sub> (L ch.) and VR<sub>402</sub> (R ch.) by rotating clockwise so that the playback level becomes 0.5dB down through the maximum value.
4. Repeat the adjustment in step 3 several times for both L- and R-channels.
5. After the step 3 adjustment is completed, set the recording bias to LH in order. Adjust the recording bias according to the procedure mentioned in step 1.
6. Assuming the value of step 3 (0.5dB down) to 0dB, confirm that the value at LH is 1.5 ± 0.5dB down.

#### 8.7 ERASE HEAD DUMMY ADJUSTMENT (Fig. 26)

1. Connect frequency counter to the test point (TP<sub>401</sub>) at OSC circuit P.C. board and the ground.
2. Set tape deck in L- and R- monophonic recording mode without loading tape. Adjust the L<sub>301</sub> (R ch.) and L<sub>302</sub> (L ch.) for oscillator frequency to obtain the identical value within stereo recording range.

#### 8.8 LEVEL METER CALIBRATION (Fig. 26)

1. Connect milli voltmeter to LINE OUTPUT terminal.
2. Apply the 1kHz, -10dBv (316mV) input signal to INPUT terminal and turn MONITOR switch to SOURCE.
3. Control the LINE recording level control for the LINE output to obtain -10dBv (316mV).
4. Adjust the VR<sub>404</sub> (L ch.) and VR<sub>405</sub> (R ch.) so that the level meter indicates "0."

#### 8.9 RECORDING SENSITIVITY ADJUSTMENT (Fig. 26)

1. Connect milli voltmeter to LINE OUTPUT terminal.
2. Apply the 1kHz, -10dBv (316mV) input signal to INPUT terminal. Record it on Scotch No. 111 tape and play back simultaneously.
3. Turn MONITOR switch to SOURCE. Control the LINE recording level control for the LINE output to obtain -10dBv (316mV).
4. Turn MONITOR switch to TAPE. Adjust the VR<sub>101</sub> (L ch.) and VR<sub>102</sub> (R ch.) for the LINE output to obtain the same value as in step 3.
5. Check to make sure that the recording level at L- and R- monophonic recording is within ±0.3dB as compared to stereo recording.

### 8.10 REC. AND P.B. FREQUENCY RESPONSE ADJUSTMENT (Figs. 26, 28)

To be made after "RECORDING BIAS ADJUSTMENT."

1. Connect milli voltmeter to LINE OUTPUT terminal.  
Apply the 1kHz, -10dBv (316mV) input signal to INPUT terminal, recording on Scotch No. 111 tape and playing back simultaneously.
2. Control the LINE recording level control for the output level to obtain -10dBv (316mV).
3. Keeping the LINE recording level control, attenuate the input level down to 20dB with attenuator to record the 1kHz and 15kHz and to play back simultaneously.
4. The output level in step 3 must fall within the specified response range as shown in Fig. 28.  
Adjust the L<sub>101</sub> (L ch.) and L<sub>102</sub> (R ch.) so that the level difference of 15kHz against 1kHz is made within  $\pm 1$ dB compared to the deviation between 1kHz and 15kHz at the "PLAYBACK FREQUENCY RESPONSE CONFIRMATION" step.
5. If the level deviation is greater than  $\pm 3$ dB, readjust after "HEAD AZIMUTH ADJUSTMENT."
6. Apply following input signals as 50, 100, 250, 2.5k, 5k, 10k, 15k and 20kHz. Check to make sure the output levels are made within the specified response ranges as shown in Fig. 28 at simultaneous recording and playback.

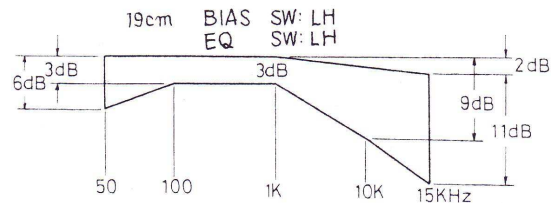
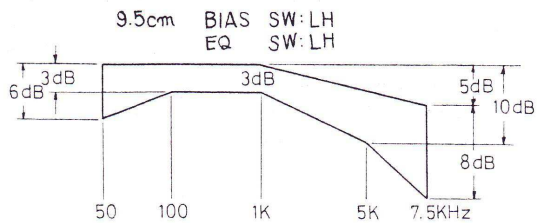
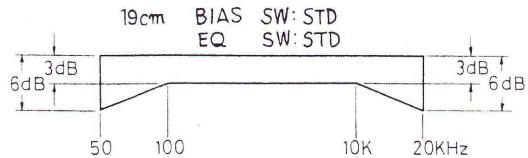
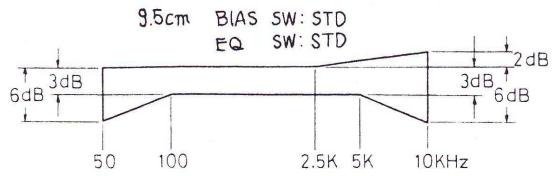

Fig. 28

## 9. SELECTION OF LINE FREQUENCY AND VOLTAGE for FV model

### 9.1 SELECTION OF LINE FREQUENCY (Figs. 29, 30)

1. Make sure power is OFF.
2. Remove back cover (A).
3. 50Hz to 60Hz:
  - Set drive belt on smaller diameter motor pulley.
4. 60Hz to 50Hz:
  - Set switches to 60Hz.
  - Set drive belt on larger diameter motor pulley.
5. Set switches to 50Hz. When drive belt is set, make sure that the belt remains in its proper position as the flywheel is rotated by hand several times.
6. Clean any spots of oil that appear on the drive belt or flywheel with absolute alcohol.

### 9.2 SWITCHING LINE VOLTAGE SETTING AND FUSE (Figs. 30, 31)

1. Make sure power is OFF.
2. Remove back cover (A), then LINE VOLTAGE SELECTOR switch is easily accessible.
3. To remove fuse, turn fuse cap.
4. Remove fuse plug from unit.
5. Put fuse plug back so as to see proper line voltage marking through cut in edge of plug.
6. 1-ampere fuse: used in either 220V or 240V area.  
2-ampere fuse: used in 110V, 120V, or 130V area.

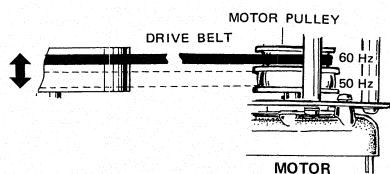

Fig. 29

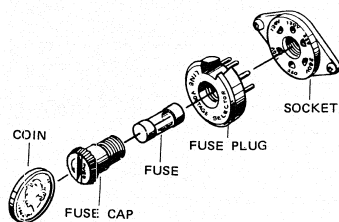

Fig. 31

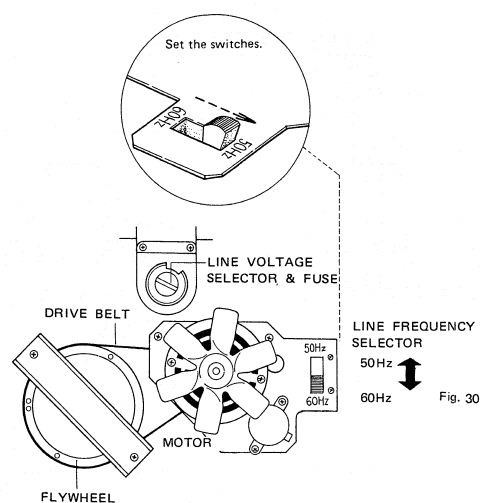
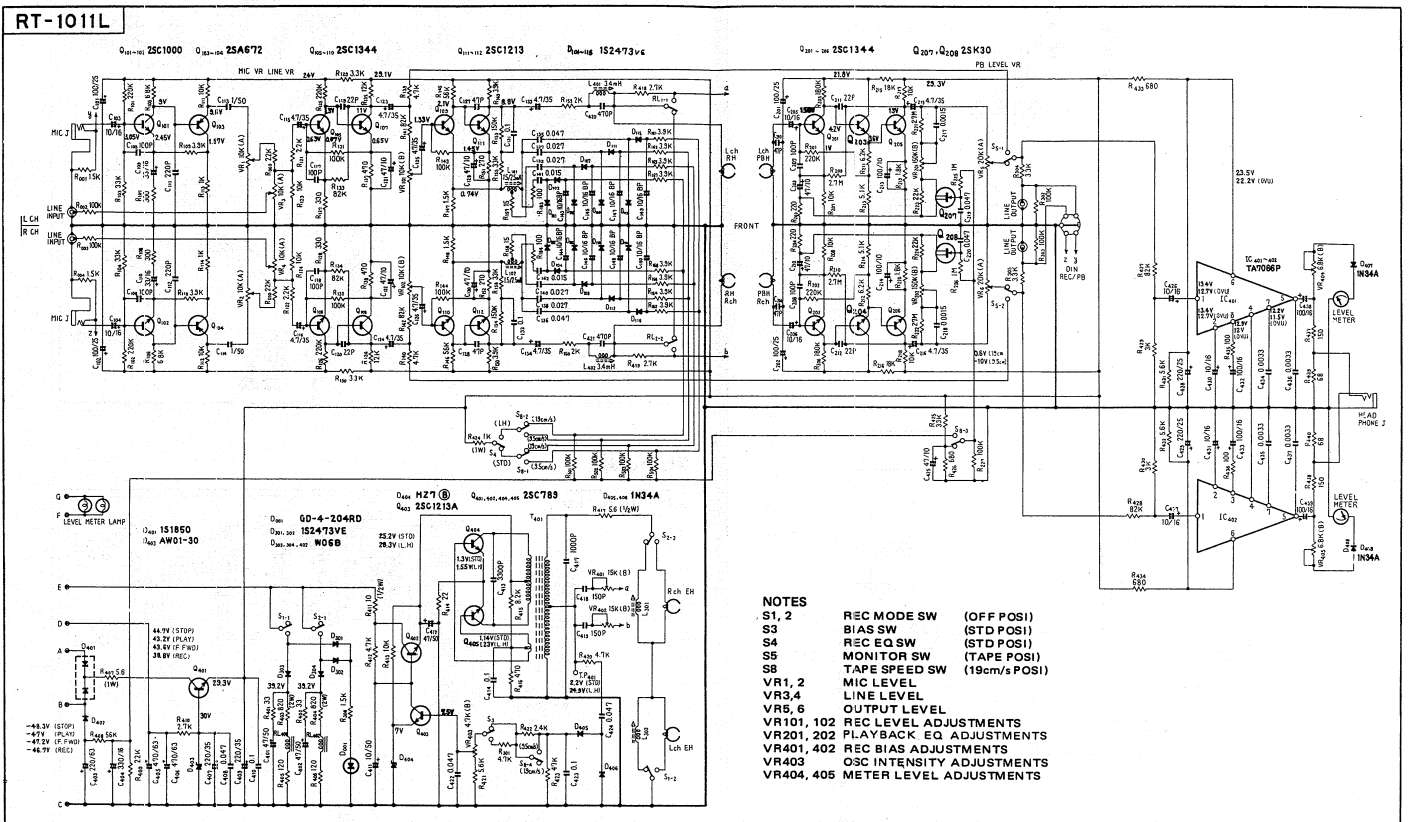

Fig. 30



10.2 SCHEMATIC DIAGRAM (AMPLIFIER)







## 10.5 ELECTRIC PARTS

## NOTE

Parts number is subject to change for the purpose of improvement with notice of a service bulletin. Service bulletin will be furnished whenever necessary and you are requested to amend parts number in this manual according to the instructions.

Symbol	Description	Part No.	
	Head P.C. board assembly	RWX-059-0	
	Control assembly	RWG-046-0	FV model
	Control assembly	RWG-047-0	KU model
	EQ switch circuit assembly	RWS-026-A	KU model
	EQ switch circuit assembly	RWS-027-B	FV model
	REC lamp P.C. board assembly	RWX-058-0	
	P.B. amplifier assembly	RWF-028-0	
	REC amplifier assembly	RWF-029-0	
	SW circuit assembly	RWS-024-0	
	OSC assembly	RWA-021-0	
	Fuse P.C. board assembly	RWX-061-A	
	Transistor P.C. board assembly	RWX-057-A	
	Motor fuse P.C. board assembly	RWX-048-0	
	Shut-off switch P.C. board assembly	RWX-047-0	
M1	Capstan motor	RXM-012-0	
M2,M3	Reel motor	RXM-017-0	
SL1	Brake solenoid	RXP-022-A	
SL2	Brake solenoid	RXP-022-A	
SL3	Pinch solenoid	RXP-021-A	
T1	Power transformer	RTT-048-A	FV model
	Power transformer	RTT-057-A	KU model
	Erase head	RPB-020-0	
	Recording head	RPB-021-B	
	Playback head	RPB-031-0	
C1	MP capacitor (A) 1+2.8 $\mu$ F 250V	RCL-015-0	
C2,C3	Phase capacitor 0.5+4 $\mu$ F 250V	RCL-010-0	
CR3,CR4	Spark killer	RWX-030-0	
S14	Frequency switch	RSH-013-0	FV model
S15	Microswitch (Shut-off)	RSF-013-0	
S6	Lever switch (PAUSE)	RSK-026-0	
D1~D3	Diode W06B		
Q1	Transistor 2SC789		
R1	Wire wound resistor (D)	RCN-023-0	
R2	Wire wound resistor (C)	RCN-022-0	
R3	Wire wound resistor (B)	RCN-021-0	
R4	Wire wound resistor (A)	RCN-020-0	
R001	Carbon film resistor 1.5k $\Omega$ 1/4W	RD1/4PS 152J	
R002	Carbon film resistor 100k $\Omega$ 1/4W	RD1/4PS 104J	
R003	Carbon film resistor 100k $\Omega$ 1/4W	RD1/4PS 104J	
R004	Carbon film resistor 1.5k $\Omega$ 1/4W	RD1/4PS 152J	
R009	Carbon film resistor 22k $\Omega$ 1/4W	RD1/4PS 223J	
R010	Carbon film resistor 22k $\Omega$ 1/4W	RD1/4PS 223J	
VR1, 2	Rec level control	RCV-010-B	
VR3, 4	Rec level control	RCV-010-B	
VR5, 6	Play back control	RCV-019-0	
	Line voltage selector switch (fuse holder)	AKR-027-0	FV model
	1A fuse	REK-033-0	FV model

# 10.6 P.B. AMPLIFIER ASSEMBLY (RWF-028)

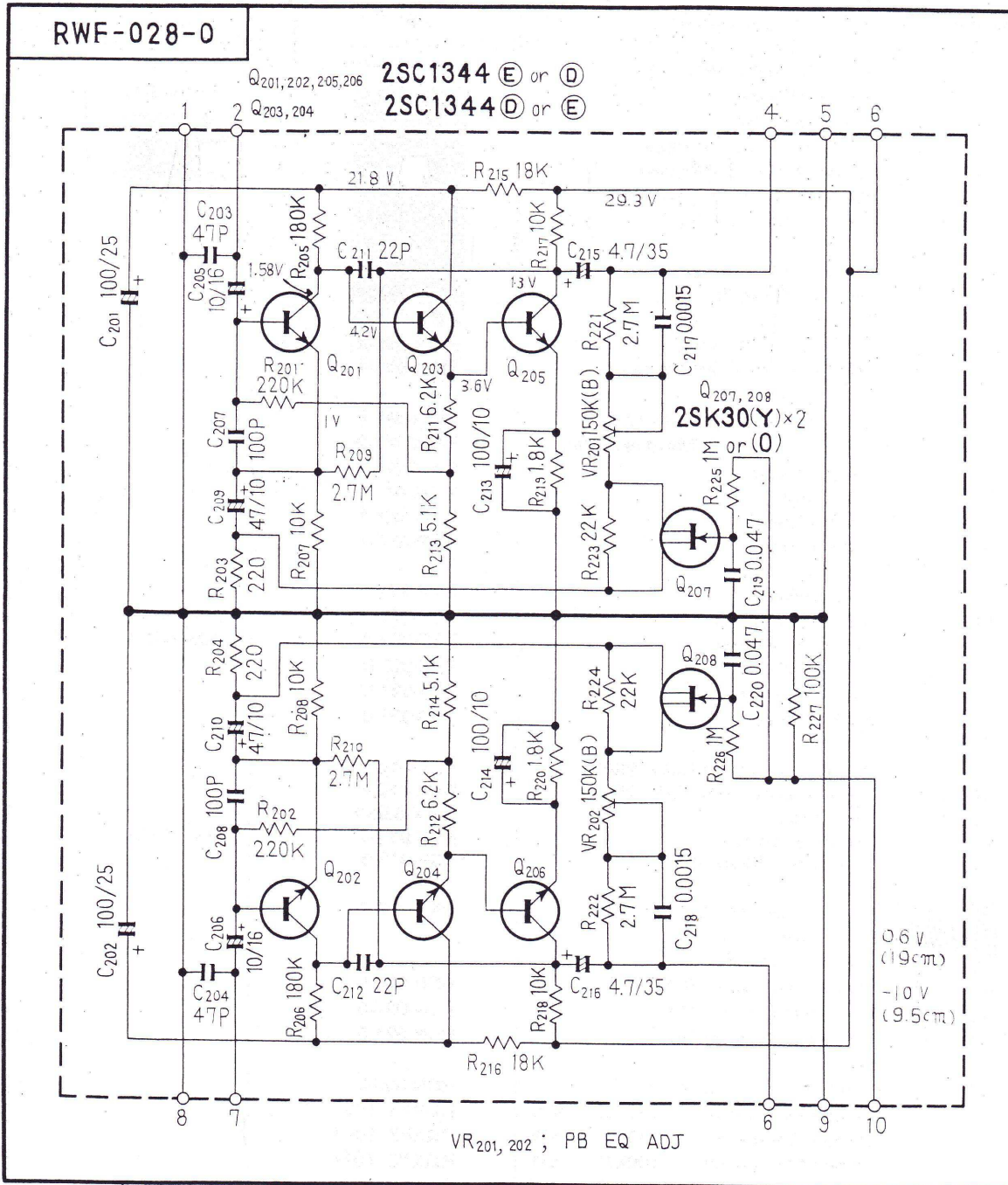

2SC1344

2SK30

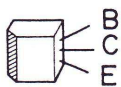



Foil side

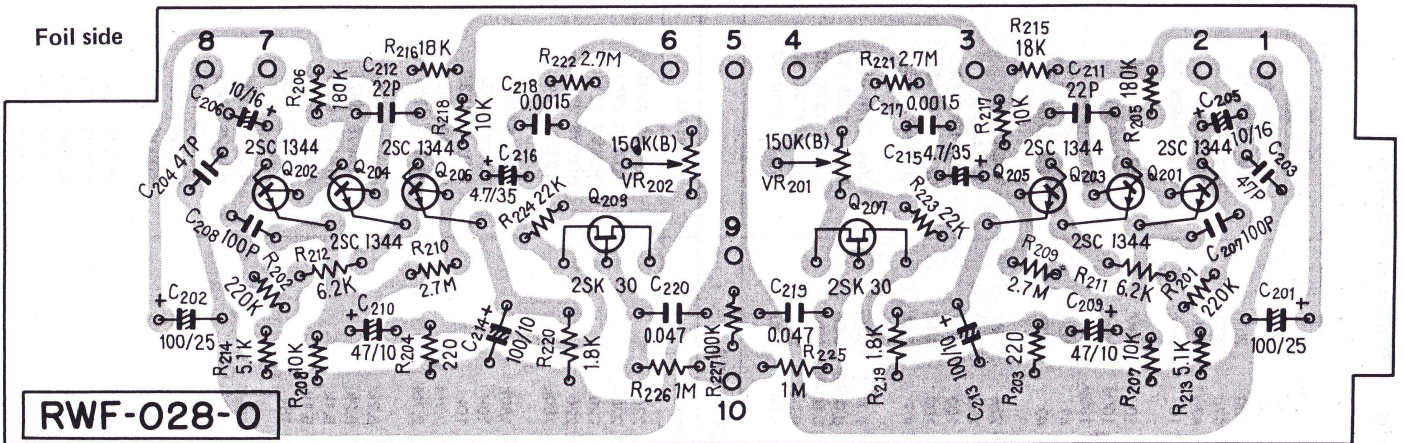



- CAPACITORS: IN  $\mu$ F UNLESS OTHERWISE NOTED p: pF
- RESISTORS: IN  $\Omega$ ,  $\frac{1}{4}$ W UNLESS OTHERWISE NOTED k: k $\Omega$ , M: M $\Omega$

## Parts List of P.B. Amplifier Assembly (RWF-028-0)

### CAPACITORS

Symbol	Description	Part No.
C201	Electrolytic 100 25V	CEA 101P 25
C202	Electrolytic 100 25V	CEA 101P 25
C203	Styrol 47p 50V	RCE-012-0
C204	Styrol 47p 50V	RCE-012-0
C205	Electrolytic 10 16V	CSZA 100M 16
C206	Electrolytic 10 16V	CSZA 100M 16
C207	Styrol 100p 50V	RCE-003-0
C208	Styrol 100p 50V	RCE-003-0
C209	Electrolytic 47 10V	CEA 470P 10
C210	Electrolytic 47 10V	CEA 470P 10
C211	Styrol 22p 50V	RCE-019-0
C212	Styrol 22p 50V	RCE-019-0
C213	Electrolytic 100 10V	CEA 101P 10
C214	Electrolytic 100 10V	CEA 101P 10
C215	Electrolytic 4.7 35V	CEA 4R7P 35
C216	Electrolytic 4.7 35V	CEA 4R7P 35
C217	Mylar 0.0015 50V	CQMA 152K 50
C218	Mylar 0.0015 50V	CQMA 152K 50
C219	Mylar 0.047 50V	CQMA 473K 50
C220	Mylar 0.047 50V	CQMA 473K 50

### RESISTORS and POTENTIOMETERS

Symbol	Description	Part No.
R201	Carbon film 220k	RD $\frac{1}{4}$ VS 224J
R202	Carbon film 220k	RD $\frac{1}{4}$ VS 224J
R203	Carbon film 220	RD $\frac{1}{4}$ VS 221J
R204	Carbon film 220	RD $\frac{1}{4}$ VS 221J
R205	Carbon film 180k	RD $\frac{1}{4}$ VS 184J
R206	Carbon film 180k	RD $\frac{1}{4}$ VS 184J
R207	Carbon film 10k	RD $\frac{1}{4}$ VS 103J
R208	Carbon film 10k	RD $\frac{1}{4}$ VS 103J
R209	Carbon film 2.7M	RD $\frac{1}{4}$ PS 275J
R210	Carbon film 2.7M	RD $\frac{1}{4}$ PS 275J
R211	Carbon film 6.2k	RD $\frac{1}{4}$ VS 622J
R212	Carbon film 6.2k	RD $\frac{1}{4}$ VS 622J
R213	Carbon film 5.1k	RD $\frac{1}{4}$ VS 512J
R214	Carbon film 5.1k	RD $\frac{1}{4}$ VS 512J
R215	Carbon film 18k	RD $\frac{1}{4}$ VS 183J
R216	Carbon film 18k	RD $\frac{1}{4}$ VS 183J
R217	Carbon film 10k	RD $\frac{1}{4}$ VS 103J
R218	Carbon film 10k	RD $\frac{1}{4}$ VS 103J
R219	Carbon film 1.8k	RD $\frac{1}{4}$ VS 182J
R220	Carbon film 1.8k	RD $\frac{1}{4}$ VS 182J
R221	Carbon film 2.7M	RD $\frac{1}{4}$ PS 275J
R222	Carbon film 2.7M	RD $\frac{1}{4}$ PS 275J
R223	Carbon film 22k	RD $\frac{1}{4}$ VS 223J
R224	Carbon film 22k	RD $\frac{1}{4}$ VS 223J
R225	Carbon film 1M	RD $\frac{1}{4}$ VS 105J

Symbol	Description	Part No.
R226	Carbon film 1M	RD¼VS 105J
VR201	Semi-fixed 150k-B	C92-860-0
VR202	Semi-fixed 150k-B	C92-860-0

**SEMICONDUCTORS**

Symbol	Description	Part No.
Q201	Transistor 2SC1344-E or D	
Q202	Transistor 2SC1344-E or D	
Q203	Transistor 2SC1344-D or E	
Q204	Transistor 2SC1344-D or E	
Q205	Transistor 2SC1344-E or D	
Q206	Transistor 2SC1344-E or D	
Q207	FET 2SK30 -Y	
Q208	FET 2SK30 -Y	

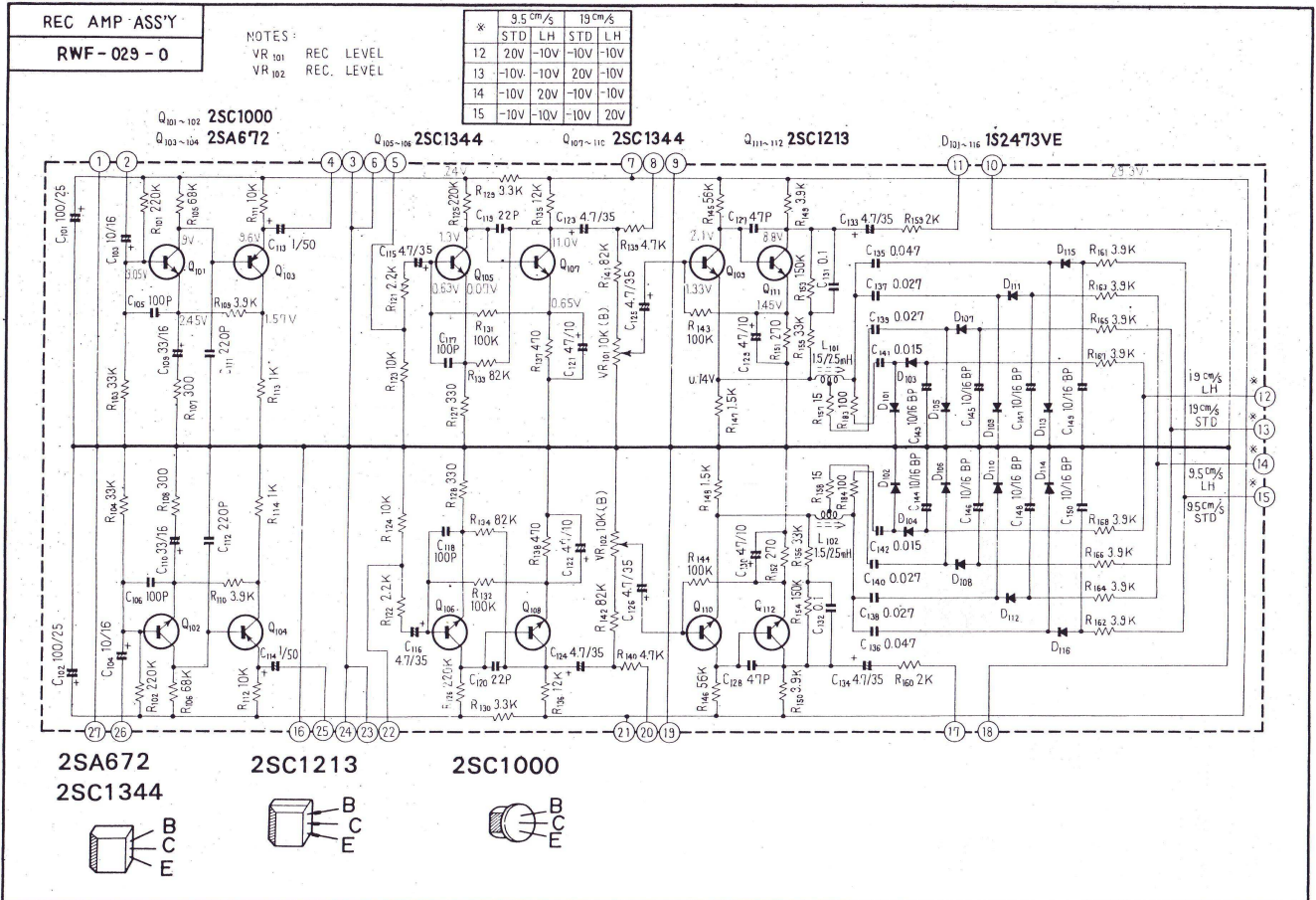







## Parts List of REC Amp Assembly (RWF-029-0)

### CAPACITORS

Symbol	Description			Part No.	
C101	Electrolytic	100	25V	CEA 101P 25	
C102	Electrolytic	100	25V	CEA 101P 25	
C103	Electrolytic	10	16V	CSZA 100M 16	
C104	Electrolytic	10	16V	CSZA 100M 16	
C105	Styrol	100p	50V	RCE-003-0	
C106	Styrol	100p	50V	RCE-003-0	
C107	.....	.....	.....	.....	
C108	.....	.....	.....	.....	
C109	Electrolytic	33	16V	CEA 330P 16	
C110	Electrolytic	33	16V	CEA 330P 16	
C111	Styrol	220p	50V	RCE-006-0	
C112	Styrol	220p	50V	RCE-006-0	
C113	Electrolytic	1	50V	CEA 010P 50	
C114	Electrolytic	1	50V	CEA 010P 50	
C115	Electrolytic	4.7	35V	CEA 4R7P 35	
C116	Electrolytic	4.7	35V	CEA 4R7P 35	
C117	Styrol	100p	50V	RCE-003-0	
C118	Styrol	100p	50V	RCE-003-0	
C119	Styrol	22p	50V	RCE-019-0	
C120	Styrol	22p	50V	RCE-019-0	
C121	Electrolytic	47	10V	CEA 470P 10	
C122	Electrolytic	47	10V	CEA 470P 10	
C123	Electrolytic	4.7	35V	CEA 4R7P 35	
C124	Electrolytic	4.7	35V	CEA 4R7P 35	
C125	Electrolytic	4.7	35V	CEA 4R7P 35	
C126	Electrolytic	4.7	35V	CEA 4R7P 35	
C127	Styrol	47p	50V	RCE-012-0	
C128	Styrol	47p	50V	RCE-012-0	
C129	Electrolytic	47	10V	CEA 470P 10	
C130	Electrolytic	47	10V	CEA 470P 10	
C131	Mylar	0.1	50V	CQMA 104K 50	
C132	Mylar	0.1	50V	CQMA 104K 50	
C133	Electrolytic	4.7	35V	CEA 4R4P 35	
C134	Electrolytic	4.7	35V	CEA 4R7P 35	
C135	Mylar	0.047	50V	CQMA 473K 50	
C136	Mylar	0.047	50V	CQMA 473K 50	
C137	Mylar	0.027	50V	CQMA 273K 50	
C138	Mylar	0.027	50V	CQMA 273K 50	
C139	Mylar	0.027	50V	CQMA 273K 50	
C140	Mylar	0.027	50V	CQMA 273K 50	
C141	Mylar	0.015	50V	CQMA 153K 50	
C142	Mylar	0.015	50V	CQMA 153K 50	
C143	Electrolytic	10	16V	RCH-011-0	Bi-polar
C144	Electrolytic	10	16V	RCH-011-0	Bi-polar
C145	Electrolytic	10	16V	RCH-011-0	Bi-polar

Symbol	Description	Part No.	
C146	Electrolytic 10 16V	RCH-011-0	Bi-polar
C147	Electrolytic 10 16V	RCH-011-0	Bi-polar
C148	Electrolytic 10 16V	RCH-011-0	Bi-polar
C149	Electrolytic 10 16V	RCH-011-0	Bi-polar
C150	Electrolytic 10 16V	RCH-011-0	Bi-polar

RESISTORS

Symbol	Description	Part No.	
R101	Carbon film 220k	RD¼VS 224J	
R102	Carbon film 220k	RD¼VS 224J	
R103	Carbon film 33k	RD¼VS 333J	
R104	Carbon film 33k	RD¼VS 333J	
R105	Carbon film 68k	RD¼VS 683J	
R106	Carbon film 68k	RD¼VS 683J	
R107	Carbon film 300	RD¼VS 301J	
R108	Carbon film 300	RD¼VS 301J	
R109	Carbon film 3.9k	RD¼VS 392J	
R110	Carbon film 3.9k	RD¼VS 392J	
R111	Carbon film 10k	RD¼VS 103J	
R112	Carbon film 10k	RD¼VS 103J	
R113	Carbon film 1k	RD¼VS 102J	
R114	Carbon film 1k	RD¼VS 102J	
R115	.....	.....	
R121	Carbon film 2.2k	RD¼VS 222J	
R122	Carbon film 2.2k	RD¼VS 222J	
R123	Carbon film 10k	RD¼VS 103J	
R124	Carbon film 10k	RD¼VS 103J	
R125	Carbon film 220k	RD¼VS 224J	
R126	Carbon film 220k	RD¼VS 224J	
R127	Carbon film 330	RD¼VS 331J	
R128	Carbon film 330	RD¼VS 331J	
R129	Carbon film 3.3k	RD¼VS 332J	
R130	Carbon film 3.3k	RD¼VS 332J	
R131	Carbon film 100k	RD¼VS 104J	
R132	Carbon film 100k	RD¼VS 104J	
R133	Carbon film 82k	RD¼VS 823J	
R134	Carbon film 82k	RD¼VS 823J	
R135	Carbon film 12k	RD¼VS 123J	
R136	Carbon film 12k	RD¼VS 123J	
R137	Carbon film 470	RD¼VS 471J	
R138	Carbon film 470	RD¼VS 471J	
R139	Carbon film 4.7k	RD¼VS 472J	
R140	Carbon film 4.7k	RD¼VS 472J	
R141	Carbon film 82k	RD¼VS 823J	
R142	Carbon film 82k	RD¼VS 823J	
R142	Carbon film 82k	RD¼VS 823J	
R143	Carbon film 100k	RD¼VS 104J	
R144	Carbon film 100k	RD¼VS 104J	
R145	Carbon film 56k	RD¼VS 563J	

Symbol	Description	Part No.
R146	Carbon film 56k	RD¼VS 563J
R147	Carbon film 1.5k	RD¼VS 152J
R148	Carbon film 1.5k	RD¼VS 152J
R149	Carbon film 3.9k	RD¼VS 392J
R150	Carbon film 3.9k	RD¼VS 392J
R151	Carbon film 270	RD¼VS 271J
R152	Carbon film 270	RD¼VS 271J
R153	Carbon film 150k	RD¼VS 154J
R154	Carbon film 150k	RD¼VS 154J
R155	Carbon film 33k	RD¼VS 333J
R156	Carbon film 33k	RD¼VS 333J
R157	Carbon film 15	RD¼VS 150J
R158	Carbon film 15	RD¼VS 150J
R159	Carbon film 2k	RD¼VS 202J
R160	Carbon film 2k	RD¼VS 202J
R161	Carbon film 3.9k	RD¼VS 392J
R162	Carbon film 3.9k	RD¼VS 392J
R163	Carbon film 3.9k	RD¼VS 392J
R164	Carbon film 3.9k	RD¼VS 392J
R165	Carbon film 3.9k	RD¼VS 392J
R166	Carbon film 3.9k	RD¼VS 392J
R167	Carbon film 3.9k	RD¼VS 392J
R168	Carbon film 3.9k	RD¼VS 392J
R169	.....	.....
R170	.....	.....
R183	Carbon film 100	RD¼VS 101J
R184	Carbon film 100	RD¼VS 101J
VR101	Semi-fixed 10k-B	C92-049-0
VR102	Semi-fixed 10k-B	C92-049-0

## SEMICONDUCTORS

Symbol	Description	Part No.
Q101	Transistor 2SC1000-GR or BL	
Q102	Transistor 2SC1000-GR or BL	
Q103	Transistor 2SA672-B or C	
Q104	Transistor 2SA672-B or C	
Q105	Transistor 2SC1344-E or D	
Q106	Transistor 2SC1344-E or D	
Q107	Transistor 2SC1344-D or E	
Q108	Transistor 2SC1344-D or E	
Q109	Transistor 2SC1344-D or E	
Q110	Transistor 2SC1344-D or E	
Q111	Transistor 2SC1213-B or C	
Q112	Transistor 2SC1213-B or C	
D101	Diode 1S2473VE	
D102	Diode 1S2473VE	
D103	Diode 1S2473VE	
D104	Diode 1S2473VE	
D105	Diode 1S2473VE	



Symbol	Description	Part No.	
D106	Diode 1S2473VE		
D107	Diode 1S2473VE		
D108	Diode 1S2473VE		
D109	Diode 1S2473VE		
D110	Diode 1S2473VE		
D111	Diode 1S2473VE		
D112	Diode 1S2473VE		
D113	Diode 1S2473VE		
D114	Diode 1S2473VE		
D115	Diode 1S2473VE		
D116	Diode 1S2473VE		

**OTHERS**

Symbol	Description	Part No.	
L101	Peaking coil RTF-011-0		
L102	Peaking coil RTF-011-0		

RWG-046-0

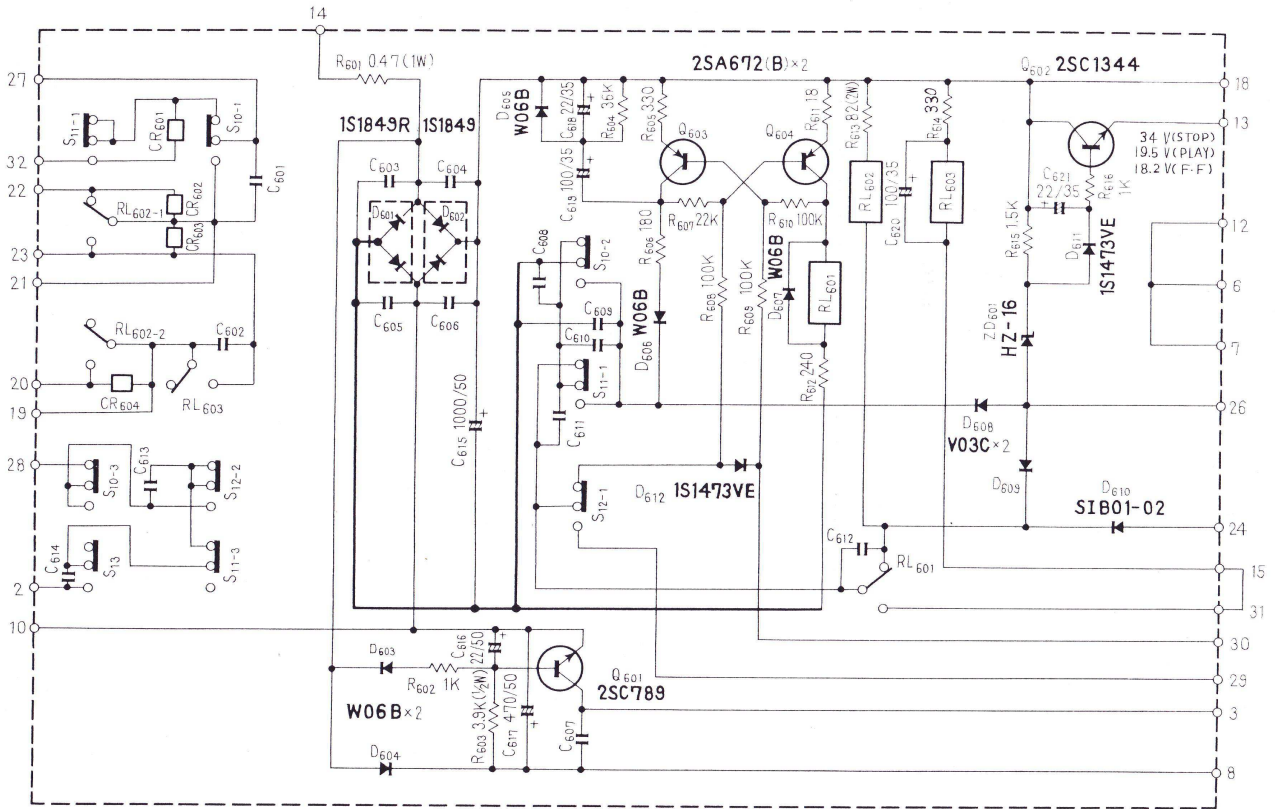

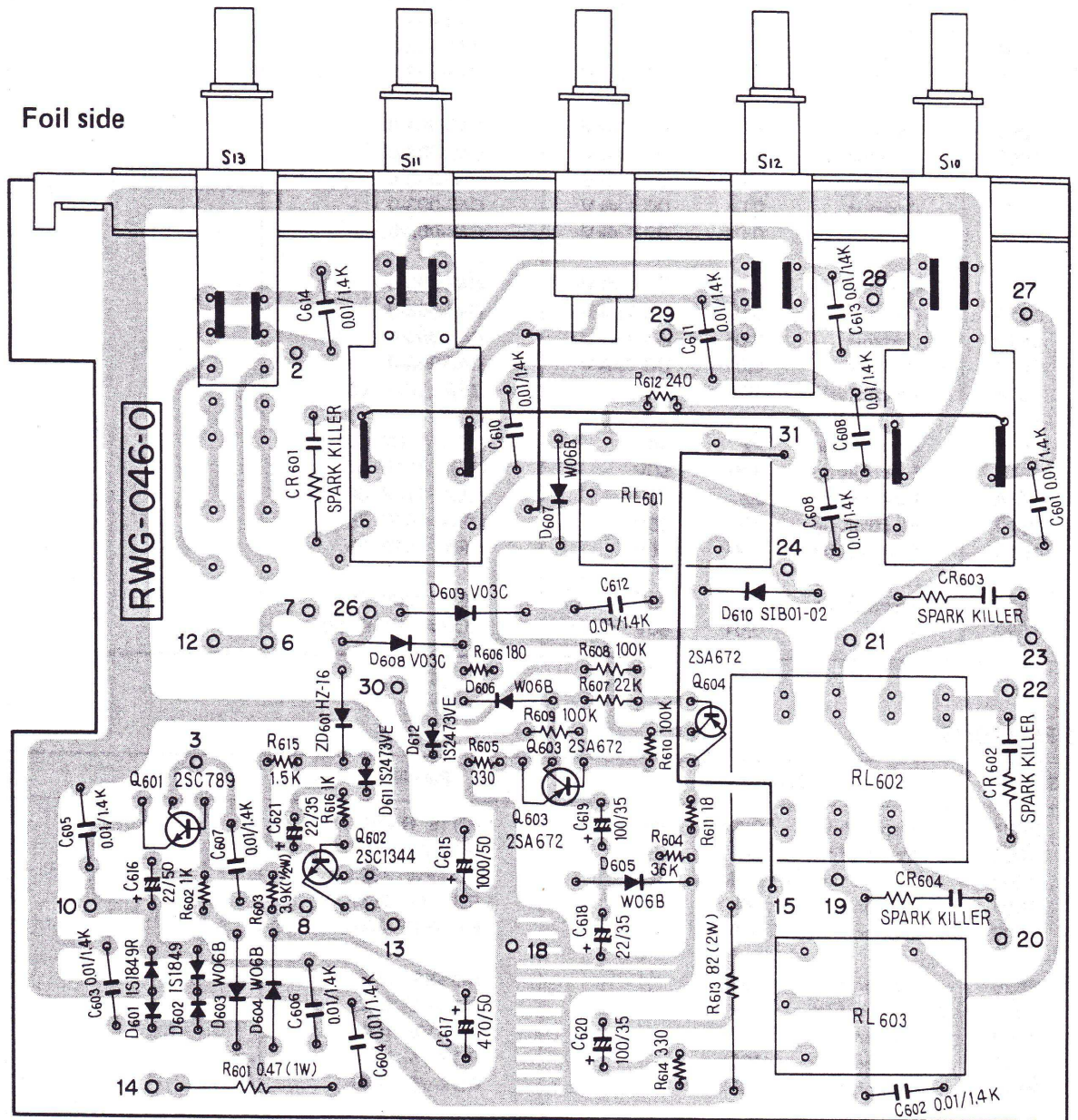

2SA672  
2SC1344

2SC789

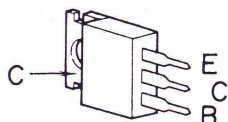
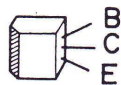



## Parts List of Control Assembly (RWG-046-0)

### CAPACITORS

Symbol	Description			Part No.
C601	Ceramic	0.01	DC 1.4kV	C43-003-0
C602	Ceramic	0.01	DC 1.4kV	C43-003-0
C603	Ceramic	0.01	DC 1.4kV	C43-003-0
C604	Ceramic	0.01	DC 1.4kV	C43-003-0
C605	Ceramic	0.01	DC 1.4kV	C43-003-0
C606	Ceramic	0.01	DC 1.4kV	C43-003-0
C607	Ceramic	0.01	DC 1.4kV	C43-003-0
C608	Ceramic	0.01	DC 1.4kV	C43-003-0
C609	Ceramic	0.01	DC 1.4kV	C43-003-0
C610	Ceramic	0.01	DC 1.4kV	C43-003-0
C611	Ceramic	0.01	DC 1.4kV	C43-003-0
C612	Ceramic	0.01	DC 1.4kV	C43-003-0
C613	Ceramic	0.01	DC 1.4kV	C43-003-0
C614	Ceramic	0.01	DC 1.4kV	C43-003-0
C615	Electrolytic	1000	50V	CEA 102P 50
C616	Electrolytic	22	50V	CEA 220P 50
C617	Electrolytic	470	50V	CEA 471P 50
C618	Electrolytic	22	35V	CEA 220P 35
C619	Electrolytic	100	35V	CEA 101P 35
C620	Electrolytic	100	35V	CEA 101P 35
C621	Electrolytic	22	35V	CEA 220P 35
C622	Mylar	0.01	50V	CQMA 103K 50

### RESISTORS

Symbol	Description			Part No.
R601	Metal film	0.47	1W	RN1S R47K
R602	Carbon film	1k		RD $\frac{1}{4}$ VS 102J
R603	Carbon film	3.9k	$\frac{1}{2}$ W	RD $\frac{1}{2}$ PW 392J
R604	Carbon film	36k		RD $\frac{1}{4}$ VS 363J
R605	Carbon film	330		RD $\frac{1}{4}$ PSF 331J
R606	Carbon film	180		RD $\frac{1}{4}$ SF 181J
R607	Carbon film	22k		RD $\frac{1}{4}$ VS 223J
R608	Carbon film	100k		RD $\frac{1}{4}$ VS 104J
R609	Carbon film	100k		RD $\frac{1}{4}$ VS 104J
R610	Carbon film	100k		RD $\frac{1}{4}$ VS 104J
R611	Carbon film	18		RD $\frac{1}{4}$ VS 180J
R612	Carbon film	240		RD $\frac{1}{4}$ PSF 241J
R613	Metal oxied	82	2W	RS2P 820J
R614	Carbon film	330		RD $\frac{1}{4}$ PSF 331 J
R615	Carbon film	1.5k		RD $\frac{1}{4}$ VS 152J
R616	Carbon film	1k		RD $\frac{1}{4}$ VS 102J



## SEMICONDUCTORS

Symbol	Description	Part No.
Q601	Transistor 2SC789-0 or Y	
Q602	Transistor 2SC1344-D or E	
Q603	Transistor 2SA672-B	
Q604	Transistor 2SA672-B	
D601	Diode 1S1849	
D602	Diode 1S1849R	
D603	Diode W-06B	
D604	Diode W-06B	
D605	Diode W-06B	
D606	Diode W-06B	
D607	Diode W-06B	
D608	Diode V-03C	
D609	Diode V-03C	
D610	Diode SIB01-02	
D611	Diode 1S2473VE	
D612	Diode 1S2473VE	
ZD601	Zener diode HZ-16	
CR601	Spark killer	RWX-030-0
CR602	Spark killer	RWX-030-0
CR603	Spark killer	RWX-030-0
CR604	Spark killer	RWX-030-0

## OTHERS

Symbol	Description	Part No.
RL601	Relay	RSR-011-0
RL602	Relay	RSR-016-0
RL603	Relay	RSR-011-0
SL601	Solenoid	RXP-019-A
S10	Push switch (F,F)	RSG-025-0
S11	Push switch (REW)	RSG-025-0
S12	Push switch (PLAY)	RSG-025-0
S13	Push switch (REC)	RSG-025-0



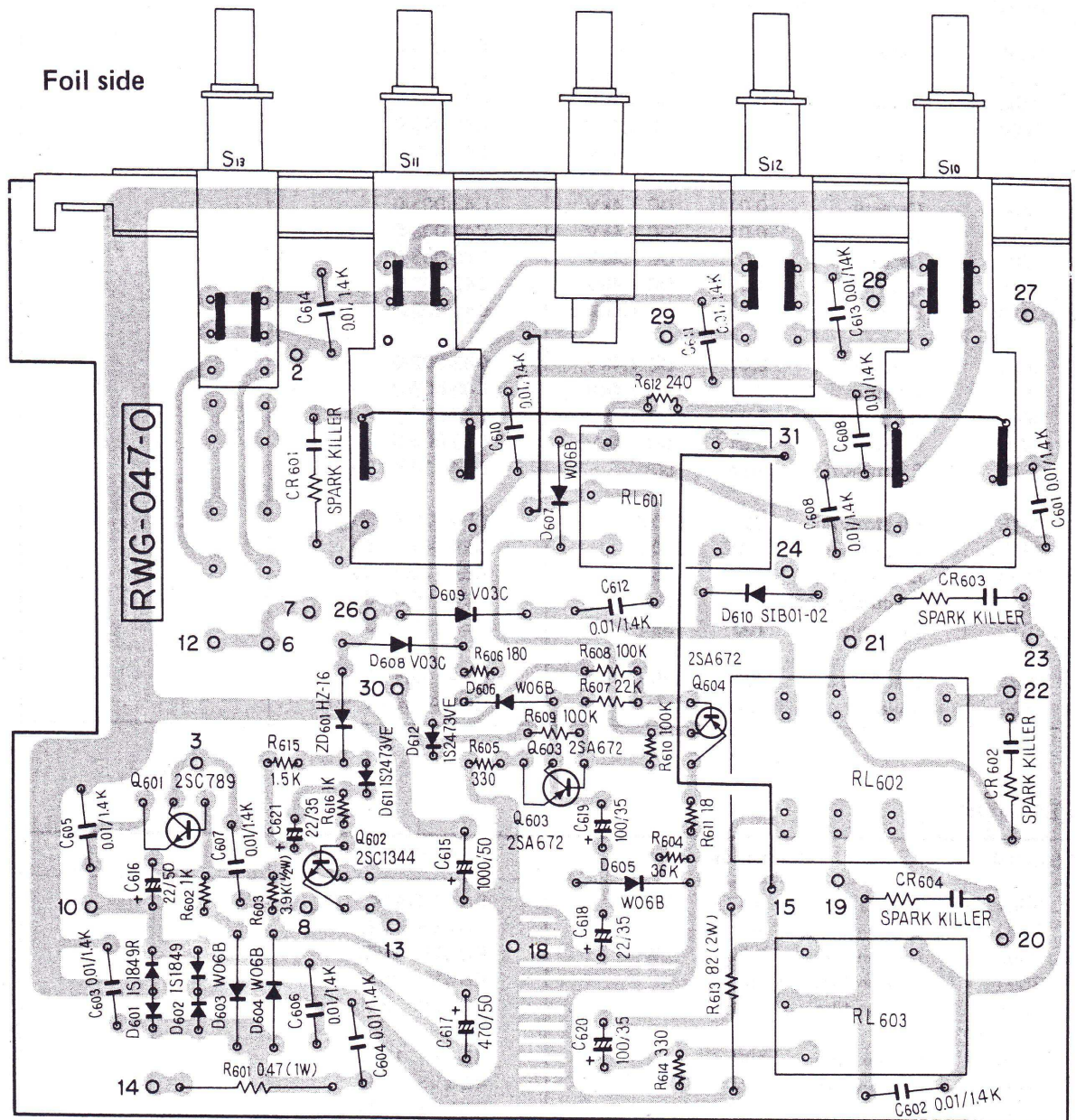

2SC1344  
2SA672

2SC789

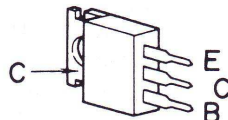
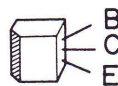



## Parts List of Control Assembly (RWG-047-0)

### CAPACITORS

Symbol	Description			Part No.
C601	Ceramic	0.01	DC 1.4kV	C43-003-0
C602	Ceramic	0.01	DC 1.4kV	C43-003-0
C603	Ceramic	0.01	DC 1.4kV	C43-003-0
C604	Ceramic	0.01	DC 1.4kV	C43-003-0
C605	Ceramic	0.01	DC 1.4kV	C43-003-0
C606	Ceramic	0.01	DC 1.4kV	C43-003-0
C607	Ceramic	0.01	DC 1.4kV	C43-003-0
C608	Ceramic	0.01	DC 1.4kV	C43-003-0
C609	Ceramic	0.01	DC 1.4kV	C43-003-0
C610	Ceramic	0.01	DC 1.4kV	C43-003-0
C611	Ceramic	0.01	DC 1.4kV	C43-003-0
C612	Ceramic	0.01	DC 1.4kV	C43-003-0
C613	Ceramic	0.01	DC 1.4kV	C43-003-0
C614	Ceramic	0.01	DC 1.4kV	C43-003-0
C615	Electrolytic	1000	50V	CEA 102P 50
C616	Electrolytic	22	50V	CEA 220P 50
C617	Electrolytic	470	50V	CEA 471P 50
C618	Electrolytic	22	35V	CEA 220P 35
C619	Electrolytic	100	35V	CEA 101P 35
C620	Electrolytic	100	35V	CEA 101P 35
C621	Electrolytic	22	35V	CEA 220P 35
C622	Mylar	0.01	50V	CQMA 103K 50

### RESISTORS

Symbol	Description			Part No.
R601	Metal film	0.47	1W	RN1S R47K
R602	Carbon film	1k		RD¼VS 102J
R603	Carbon film	3.9k	½W	RD½PW 392J
R604	Carbon film	36k		RD¼VS 363J
R605	Carbon film	330		RD¼PSF 331J
R606	Carbon film	180		RD¼SF 181J
R607	Carbon film	22k		RD¼VS 223J
R608	Carbon film	100k		RD¼VS 104J
R609	Carbon film	100k		RD¼VS 104J
R610	Carbon film	100k		RD¼VS 104J
R611	Carbon film	18		RD¼VS 180J
R612	Carbon film	240		RD¼PSF 241J
R613	Metal oxid	82	2W	RS2P 820J
R614	Carbon film	330		RD¼PSF 331 J
R615	Carbon film	1.5k		RD¼VS 152J
R616	Carbon film	1k		RD¼VS 102J



**SEMICONDUCTORS**

Symbol	Description	Part No.
Q601	Transistor 2SC789-0 or Y	
Q602	Transistor 2SC1344-D or E	
Q603	Transistor 2SA672-B	
Q604	Transistor 2SA672-B	
D601	Diode 1S1849	
D602	Diode 1S1849R	
D603	Diode W-06B	
D604	Diode W-06B	
D605	Diode W-06B	
D606	Diode W-06B	
D607	Diode W-06B	
D608	Diode V-03C	
D609	Diode V-03C	
D610	Diode S1B01-02	
D611	Diode 1S2473VE	
D612	Diode 1S2473VE	
ZD601	Zener diode HZ-16	
CR601	Spark killer	RWX-030-0
CR602	Spark killer	RWX-030-0
CR603	Spark killer	RWX-030-0
CR604	Spark killer	RWX-030-0

**OTHERS**

Symbol	Description	Part No.
RL601	Relay	RSR-017-0
RL602	Relay	RSR-016-0
RL603	Relay	RSR-017-0
SL601	Solenoid	RXP-019-A
S10	Push switch (F.F)	RSG-025-0
S11	Push switch (REW)	RSG-025-0
S12	Push switch (PLAY)	RSG-025-0
S13	Push switch (REC)	RSG-025-0

10.10 SWITCH CIRCUIT ASSEMBLY (RWS-024)

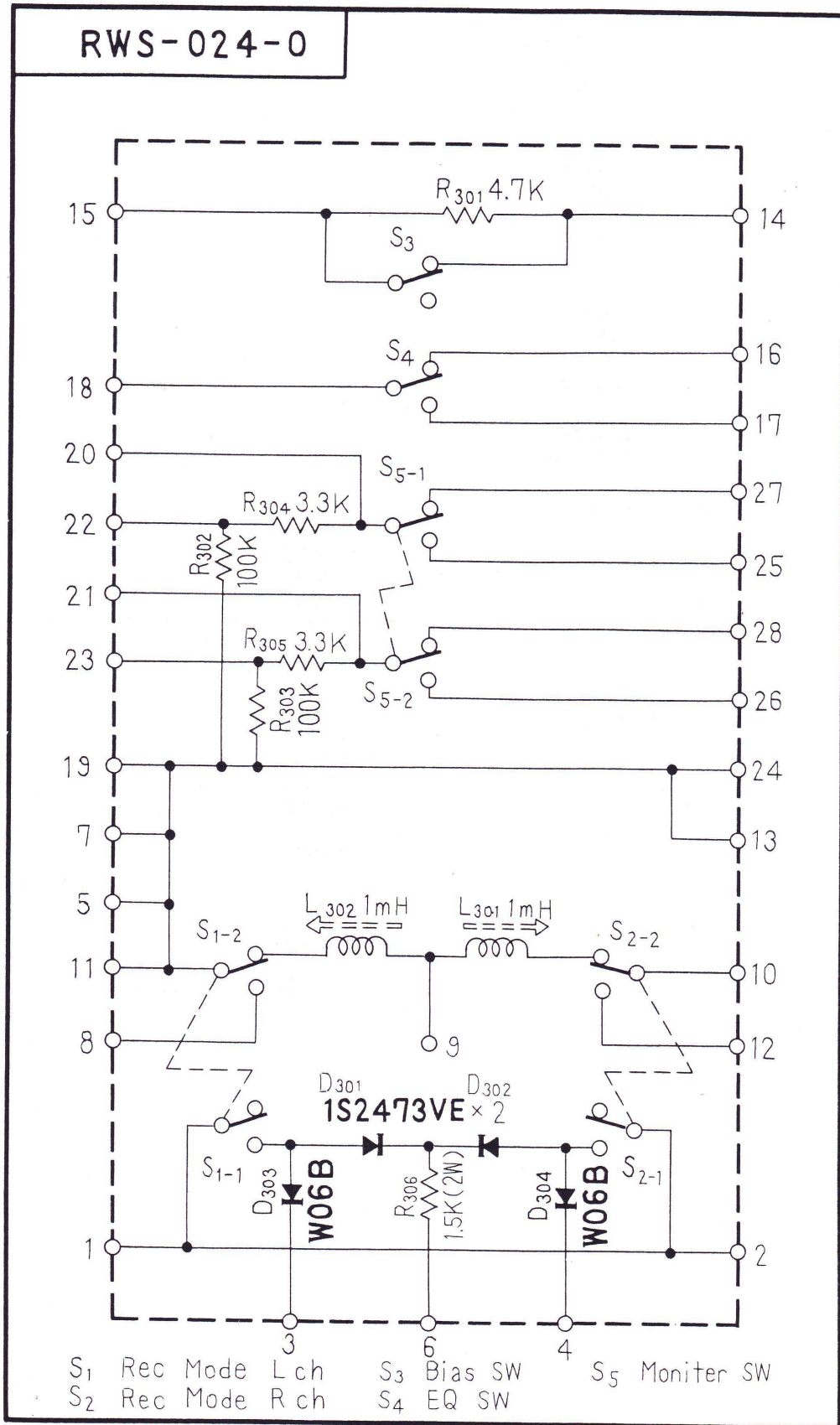

Parts List of SW Assembly (RWS-024-0)

RESISTORS and DIODE

Symbol	Description	Part No.
R301	Carbon film 4.7k	RD%VS 472J
R302	Carbon film 100k	RD%VS 104J
R303	Carbon film 100k	RD%VS 104J
R304	Carbon film 3.3k	RD%VS 332J
R305	Carbon film 3.3k	RD%VS 332J
R306	Metal oxidied 1.5k 2W	RS2P 152J
D301	Diode 1S2473VE	
D302	Diode 1S2473VE	
D303	Diode W-06B	
D304	Diode W-06B	

OTHER

Symbol	Description	Part No.
S1	lever switch (REC. MODE)	RSK-018-0
S2	lever switch (REC. MODE)	RSK-018-0
S3	lever switch (BIAS)	RSK-018-0
S4	lever switch (EQ)	RSK-018-0
S5	lever switch (MONITOR)	RSK-018-0
L301	Dummy coil	RTD-008-0
L302	Dummy coil	RTD-008-0

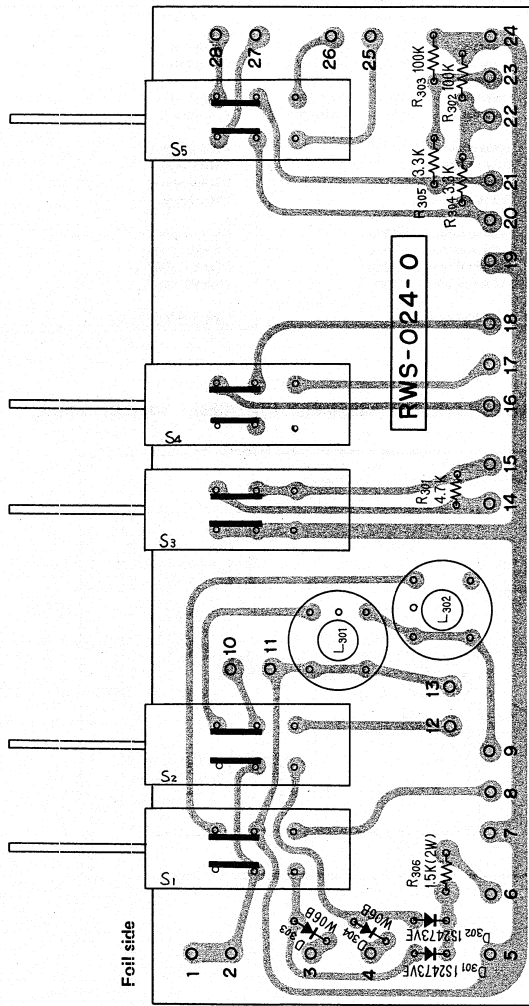

10.11 EQ. SWITCH CIRCUIT ASSEMBLY (RWS-027) for FV model

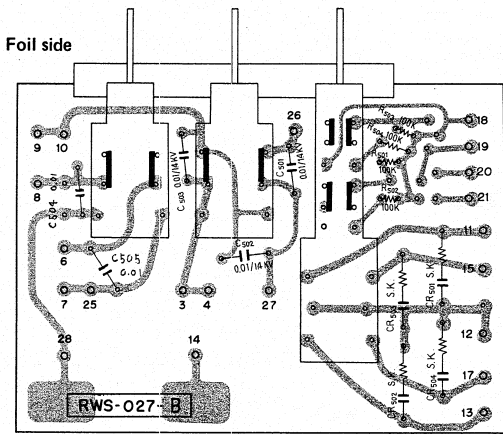
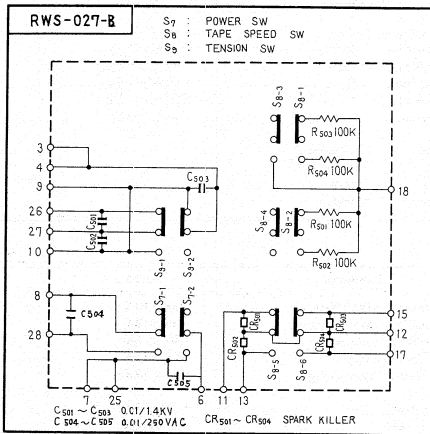

Parts List of EQ, SW Assembly (RWS-027)

Symbol	Description	Part No.
C501	Ceramic 0.01 DC1.4kV	C43-003-0
C502	Ceramic 0.01 DC1.4kV	C43-003-0
C503	Ceramic 0.01 DC1.4kV	C43-003-0
C504	Ceramic 0.01 AC 250V	ACG-001-0
C505	Ceramic 0.01 AC 250V	ACG-001-0
CR501	Spark killer	RWX-030-0
CR502	Spark killer	RWX-030-0
CR503	Spark killer	RWX-030-0
CR504	Spark killer	RWX-030-0
R501	Carbon film 100k	RD%VS 104J
R502	Carbon film 100k	RD%VS 104J
R503	Carbon film 100k	RD%VS 104J
R504	Carbon film 100k	RD%VS 104J
	Push switch	RSG-014-0

10.12 EQ. SWITCH CIRCUIT ASSEMBLY (RWS-026) for KU model

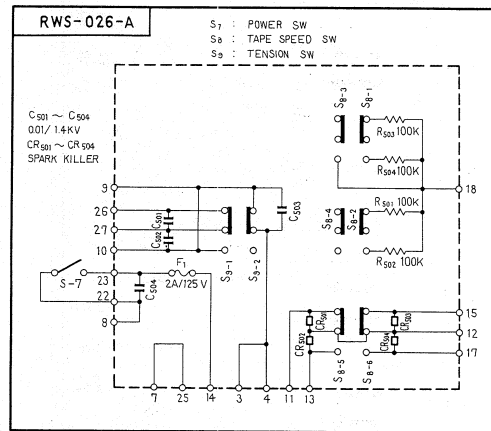



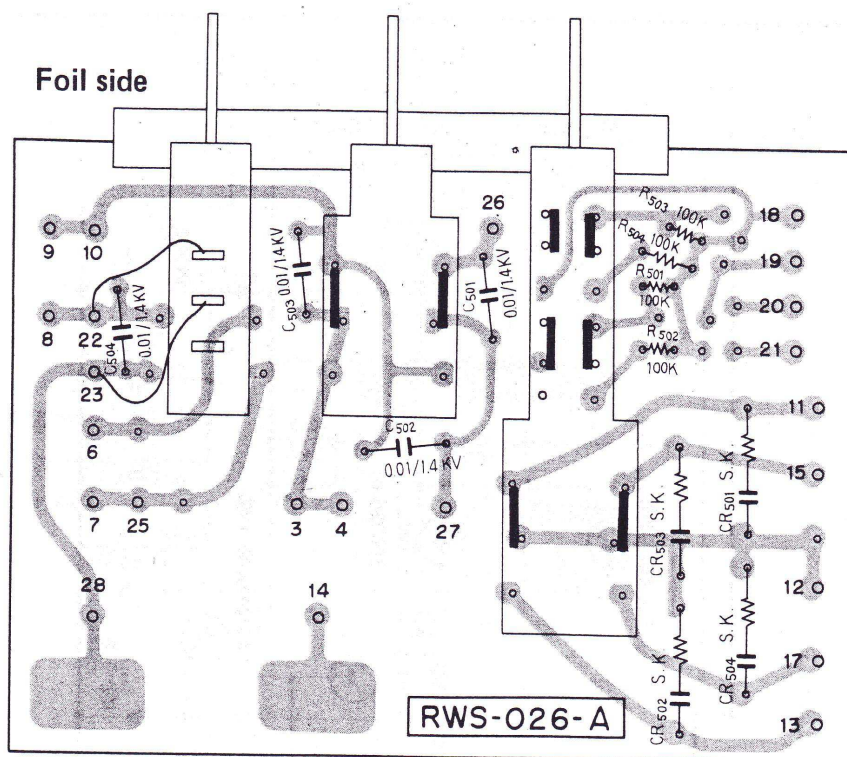

Parts List of EQ, SW Assembly (RWS-026)

Symbol	Description		Part No.
C501	Ceramic	0.01 DC 1.4kv	C43-003-0
C502	Ceramic	0.01 DC 1.4kv	C43-003-0
C503	Ceramic	0.01 DC 1.4kv	C43-003-0
C504	Ceramic	0.01 DC 1.4kv	C43-003-0
CR501	Spark killer		RWX-030-0
CR502	Spark killer		RWX-030-0
CR503	Spark killer		RWX-030-0
CR504	Spark killer		RWX-030-0
R501	Carbon film	100k	RD¼VS 104J
R502	Carbon film	100k	RD¼VS 104J
R503	Carbon film	100k	RD¼VS 104J
R504	Carbon film	100k	RD¼VS 104J
F1	Fuse	2A 125V	REK-034-0
	Push switch		RSG-021-0

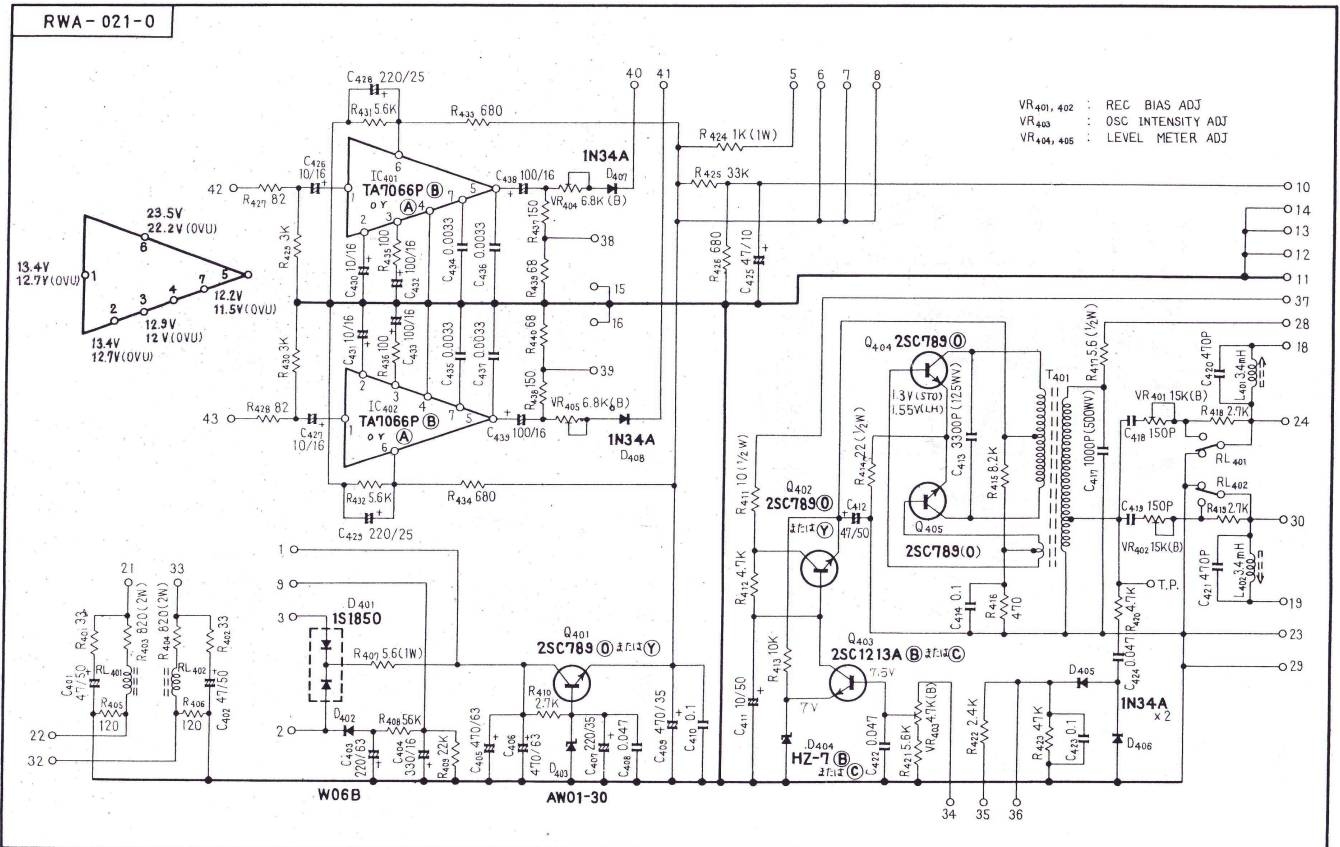

Foil side

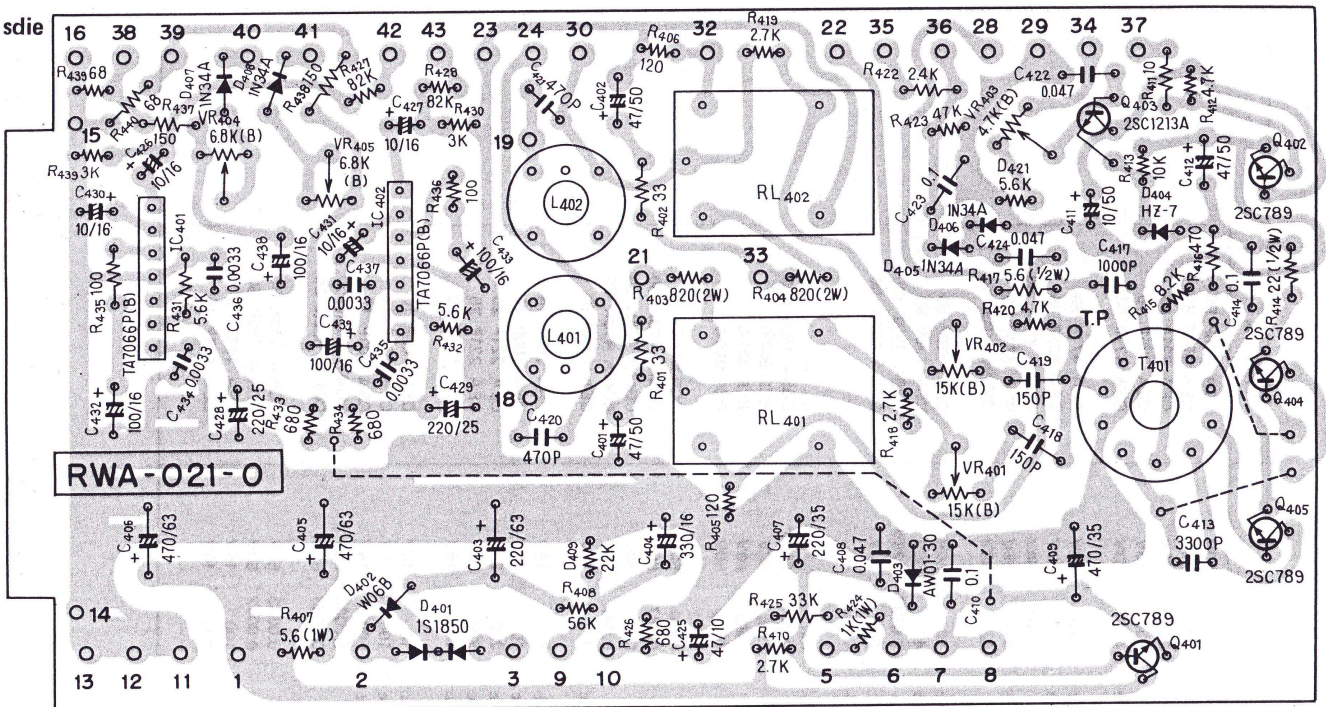

RWA-021-0

2SC1213A

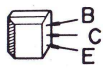

2SC789

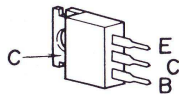



## Parts List of OSC. Assembly (RWA-021-0)

### CAPACITORS

Symbol	Description			Part No.
C401	Electrolytic	47	50V	CEA 470P 50
C402	Electrolytic	47	50V	CEA 470P 50
C403	Electrolytic	220	63V	CEA 221P 63
C404	Electrolytic	330	16V	CEA 331P 16
C405	Electrolytic	470	63V	CEA 471P 63
C406	Electrolytic	470	63V	CEA 471P 63
C407	Electrolytic	220	35V	CEA 221P 35
C408	Mylar	0.047	50V	CQMA 473K 50
C409	Electrolytic	470	35V	CEA 471P 35
C410	Mylar	0.1	50V	CQMA 104K 50
C411	Electrolytic	10	50V	CEA 100P 50
C412	Electrolytic	47	50V	CEA 470P 50
C413	Styrol	0.0033	125V	CQSA 332J 125
C414	Mylar	0.1	50V	CQMA 104K 50
C415	.....	.....	.....	.....
C416	.....	.....	.....	.....
C417	Styrol	0.001	500V	CQSA 102J 500
C418	Styrol	150p	50V	RCE-007-0
C419	Styrol	150p	50V	RCE-007-0
C420	Styrol	470p	50V	RCE-014-0
C421	Styrol	470p	50V	RCE-014-0
C422	Mylar	0.047	50V	CQMA 473K 50
C423	Mylar	0.1	50V	CQMA 104K 50
C424	Mylar	0.047	50V	CQMA 473K 50
C425	Electrolytic	47	10V	CEA 470P 10
C426	Electrolytic	10	16V	CEA 100P 16
C427	Electrolytic	10	16V	CEA 100P 16
C428	Electrolytic	220	25V	CEA 221P 25
C429	Electrolytic	220	25V	CEA 221P 25
C430	Electrolytic	10	16V	CEA 100P 16
C431	Electrolytic	10	16V	CEA 100P 16
C432	Electrolytic	100	16V	CEA 101P 16
C423	Electrolytic	100	16V	CEA 101P 16
C434	Mylar	0.0033	50V	CQMA 332K 50
C435	Mylar	0.0033	50V	CQMA 332K 50
C436	Mylar	0.0033	50V	CQMA 332K 50
C437	Mylar	0.0033	50V	CQMA 332K 50
C438	Electrolytic	100	16V	CEA 101P 16
C439	Electrolytic	100	16V	CEA 101P 16
C440	.....	.....	.....	.....

RESISTORS

Symbol	Description	Part No.
R401	Carbon film 33	RD%VS 330J
R402	Carbon film 33	RD%VS 330J
R403	Metal oxide 820 2W	RS2P 821J
R404	Metal oxide 820 2W	RS2P 821J
R405	Carbon film 120	RD%VS 121J
R406	Carbon film 120	RD%VS 121J
R407	Metal film 5.6 1W	RN1S 5R6K
R408	Carbon film 56k	RD%VS 563J
R409	Carbon film 22k	RD%VS 223J
R410	Carbon film 2.7k	RD%VS 272J
R411	Carbon film 10	RD%VS 100J
R412	Carbon film 4.7k	RD%VS 472J
R413	Carbon film 10k	RD%VS 103J
R414	Carbon film 22 1/2W	RD%PW 220J
R415	Carbon film 8.2k	RD%VS 822J
R416	Carbon film 470	RD%VS 471J
R417	Carbon film 5.6 1/2W	RD%PW 5R6J
R418	Carbon film 2.7k	RD%VS 272J
R419	Carbon film 2.7k	RD%VS 272J
R420	Carbon film 4.7k	RD%VS 472J
R421	Carbon film 5.6k	RD%VS 562J
R422	Carbon film 2.4k	RD%VS 242J
R423	Carbon film 47k	RD%VS 473J
R424	Metal oxide 1k 1W	RS1P 102J
R425	Carbon film 33k	RD%VS 333J
R426	Carbon film 680	RD%VS 681J
R427	Carbon film 82k	RD%VS 823J
R428	Carbon film 82k	RD%VS 823J
R429	Carbon film 3k	RD%VS 302J
R430	Carbon film 3k	RD%VS 302J
R431	Carbon film 5.6k	RD%VS 562J
R432	Carbon film 5.6k	RD%VS 562J
R433	Carbon film 680	RD%VS 681J
R434	Carbon film 680	RD%VS 681J
R435	Carbon film 100	RD%VS 101J
R436	Carbon film 100	RD%VS 101J
R437	Carbon film 150	RD%VS 151J
R438	Carbon film 150	RD%VS 151J
R439	Carbon film 68	RD%VS 680J
R440	Carbon film 68	RD%VS 680J
VR401	Semi-fixed 15k-B	RCP-006-0
VR402	Semi-fixed 15k-B	RCP-006-0
VR403	Semi-fixed 4.7k-B	C92-051-0
VR404	Semi-fixed 6.3k-B	RCP-001-0
VR405	Semi-fixed 6.3k-B	RCP-001-0

SEMICONDUCTORS

Symbol	Description	Part No.
Q401	Transistor 2SC789-0 or Y	
Q402	Transistor 2SC789-0 or Y	
Q403	Transistor 2SC1213A-B	
Q404	Transistor 2SC789-0 or Y	
Q405	Transistor 2SC789-0 or Y	
IC401	IC TA7066P	
IC402	IC TA7066P	
D401	Diode 1S1850	
D402	Diode W-06B	
D403	Diode AW01-30	
D404	Zener diode HZ-7-B	
D405	Diode 1N34A	
D406	Diode 1N34A	
D407	Diode 1N34A	
D408	Diode 1N34A	

OTHERS

Symbol	Description	Part No.
RL1	Relay	RSR-018-0
RL2	Relay	RSR-018-0
T401	O.S.C. coil	RTD-007-0
L401	Trap coil	RTF-006-0
L402	Trap coil	RTF-006-0

10.14 FUSE P.C. BOARD ASSEMBLY (RWX-061)

Foil side

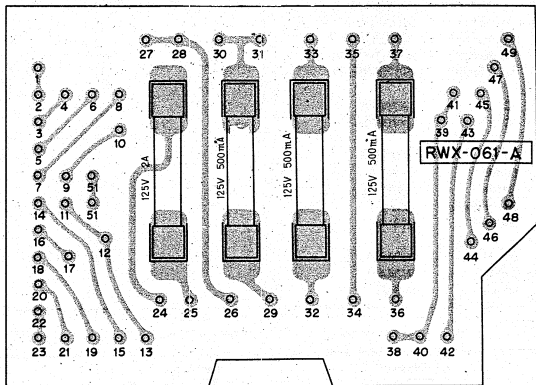

Parts List of Fuse Board Assembly (RWX-061-A)

Symbol	Description	Part No.
	Fuse 500mA	REK-031-0
	Fuse 2A	REK-034-0
	Fuse holder	K91-006-0

10.15 REC. LAMP P.C. BOARD ASSEMBLY (RWX-058)

Foil Side

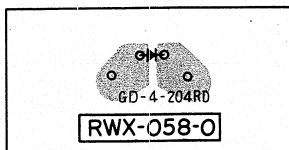

Symbol	Description	Part No.
D001	Light-emitting diode GD-4-204RD	

10.16 SHUT-OFF SWITCH P.C. BOARD ASSEMBLY (RWX-047)

Foil side

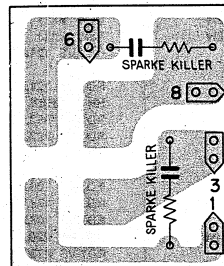

Symbol	Description	Part No.
	Spark killer	RWX-030-0

10.17 MOTOR FUSE BOARD ASSEMBLY (RWX-048)

Foil side

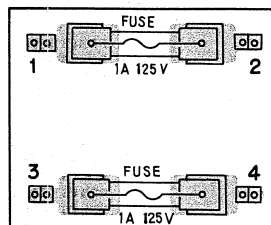

Symbol	Description	Part No.
	Fuse holder	K91-006-0
	Fuse 1A	REK-033-0



## 11. EXPLODED VIEWS AND PARTS LISTS

The following symbols stand for screws, nuts, washers, etc. as shown in EXPLODED VIEWS on pp. 67 ~ 80.

P	: Pan head screw	T	: Tapping screw
B	: Binding head screw	E	: Retaining washer E-type
C	: Countersunk head screw	SW	: Spring washer
TS	: Truss head screw	N	: Hexagonal nut
PS	: Pan head sems screw	OC	: Oval countersunk head screw
S	: Setscrew		

### 11.1 PANEL AND BACK COVER

NOTICE: Any parts asterisked (\*) are subject to being not supplied.

Key No.	Description	Part No.	
1	Roller cover (A)	RAH-106-0	
2	Ball bearing	RNX-003-0	
3	Roller cover (B)	RAH-107-0	
4	Roller arm guide	RLA-429-0	
5	Roller arm assembly	RXA-511-0	
6	Roller arm spring	RBH-194-0	
7	Washer 6φ BN2	B22-425-0	
8	Arm lock spring	RBK-073-0	
9	Roller guide assembly	RXA-510-0	
10	Washer BN2	B22-425-0	
11	Meter escutcheon	REC-170-A	
12	Shading washer	REB-052-0	
13	Head cover assembly	RXX-150-0	including key No. 55
14	Roller arm shaft	RLA-428-0	
15	Pinch roller cap	RAT-002-A	
16	Pinch felt	RED-053-0	
17	Washer 6φ BN1	B22-426-0	
18	Pinch roller assembly	RXA-309-0	
19	Washer 6φ BN1	B22-426-0	
20	Cap	RAT-007-0	
21	Reel base assembly	RXA-436-0	
22	Tension arm plate	RAH-079-A	
23	Tension arm assembly	RXA-310-D	
24	Tape guide (C)	RLA-309-A	
25	Lever switch knob (B) assembly	RAA-062-B	
26	Frame (A)	RAP-035-0	
27	Mech. panel assembly	RXX-147-0	including key No. 52, 56
28	Frame (B)	RAP-046-0	
29	Side Board	RMS-036-0	
30	Special screw M4 x 15	ABA-010-0	
31	AMP panel assembly	RXX-146-0	including key No. 33, 57
32	Lever switch knob	RAA-102-0	
33	Masking plate	RED-079-0	
34	Washer	RBF-018-0	
35	Double knob inner (REC LEVEL)	RAA-097-A	

Continued on the Next Page

NOTICE: Any parts asterisked (\*) are subject to being not supplied.

Key No.	Description	Part No.	
36	Double knob outer (REC LEVEL)	RAA-096-A	
37	.....	.....	
38	Washer 3φ BN1	B22-420-0	
39	.....	.....	
40	Plate	REE-046-A	
41	Special screw M4 x 15	ABA-010-0	
42	Sideboard	RMS-036-0	
43	Flame (B)	RAP-046-0	
44 *	Cover cushion (A)	REB-099-0	including key No. 44
45	Back cover (A) assembly	RXX-112-0	
46	Cover cushion (B)	REB-100-0	
47	.....	.....	
48	Back cover (B)	RNA-164-0	
49	Foot (A)	REC-116-A	
50	Foot (B)	REC-119-A	
51	.....	.....	
52 *	Masking plate (B)	RED-065-0	
53	Double knob inner (OUTPUT LEVEL)	RAA-103-A	
54	Double knob outer (OUTPUT LEVEL)	RAA-099-A	
55 *	Name plate (model)	RAL-130-0	
56 *	Counter escutcheon	REC-168-A	
57 *	REC lamp escutcheon	RAT-005-A	

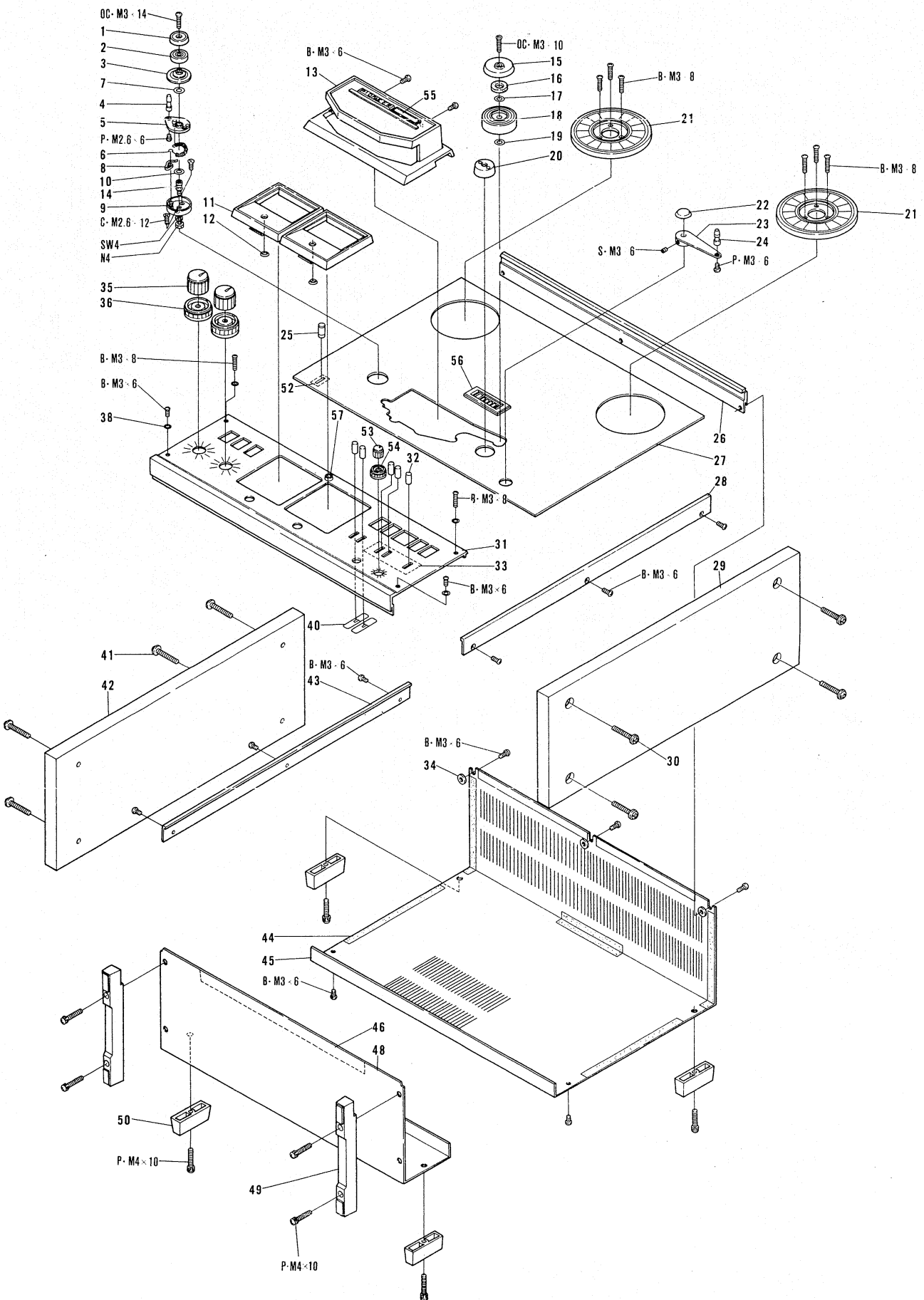



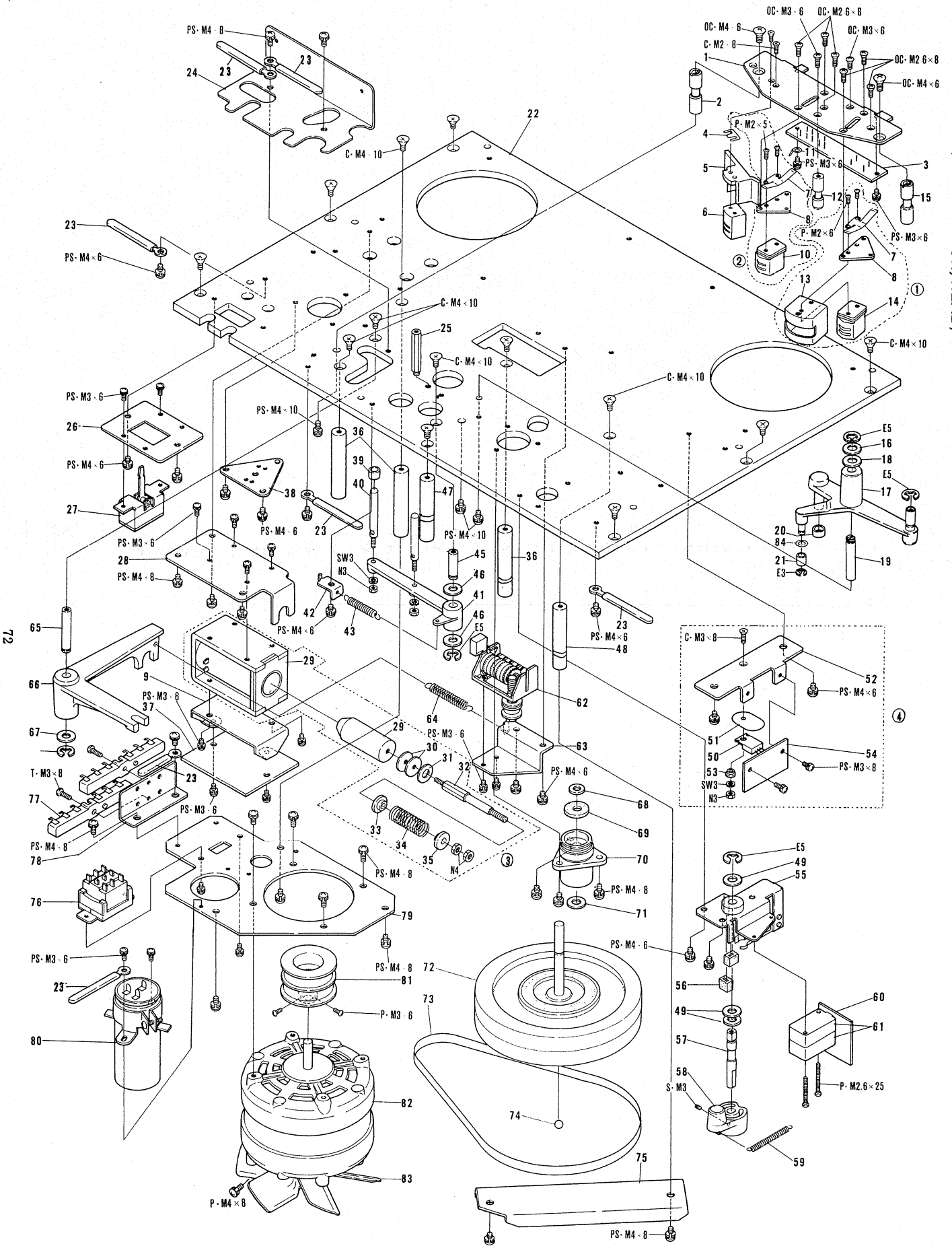

NOTICE: Any parts asterisked (\*) are subject to being not supplied.

Key No.	Description	Part No.	
1 *	Head base	RNE-739-0	NOTE 1
2	Tape guide (A)	RLA-300-B	
3	Head P.C. board assembly	RWX-059-0	
4	E.H. adj spacer (B)	REF-005-0	
5	Spacer (erase head)	REC-122-A	
6	Erase head	RPB-020-0	
7	Head adj spring	RBK-060-B	
8 *	Head mounting metal	RNE-738-0	
9 *	Motor Fuse P.C. board holder	RNE-680-0	
10	Recording head	RPB-021-B	
11 *	Plate solder lug 3φ		
12	Tape guide (B)	PLA-301-A	
13	Shield case (A)	RNA-095-A	
14	Playback head	RPB-031-0	
15	Tape guide (A)	RLA-300-B	
16	Washer 6φ BN1	B22-426-0	
17	Pinch arm (A) assembly	RXA-399-0	
18	Washer 6φ BN 2	B22-425-0	
19 *	Pinch arm shaft	RLA-307-0	
20	Pinch arm damper	REB-078-0	
21 *	Shifter roller	RLP-004-0	
22 *	Mechanism chassis	RNB-030-F	
23 *	Cord fixer	RNE-513-0	
24 *	Shield plate	RNE-737-0	
25 *	Pole	RLA-311-B	
26 *	Switch mounting plate	RNE-393-0	
27	Lever switch	RSK-026-0	
28 *	Solenoid bracket	RNE-386-B	
29	Pinch solenoid	RXP-021-0	
30 *	Washer 4.2φ x14φ x1t		
31	Washer 6φ BN1	B22-426-0	
32 *	Solenoid shaft	RLA-435-0	
33	Stepped washer	RLA-433-0	
34	Pinch pressure spring	RBH-146-0	
35	Stepped washer	RLA-433-0	
36 *	Pole	RLA-417-0	
37	Motor Fuse board assembly	RWX-048-0	
38 *	Roller bracket	RNE-735-0	
39	Shifter damper	REB-109-0	
40	Shifter pole	RLA-356-A	
41 *	Shifter arm	RNG-053-A	
42 *	Spring hook	RNE-406-0	
43	Shifter spring	RBH-169-0	
44	.....	.....	
45 *	Shifter arm shaft	RLA-297-0	
46	Washer	B22-425-0	
47 *	Flywheel prop (L)	RLA-415-0	
48 *	Flywheel prop (L)	RLA-415-0	
49	Washer 6φ BN1	B22-426-0	
50	Transistor 2SC789-D or Y		

NOTICE: Any parts asterisked (\*) are subject to being not supplied.

Key No.	Description	Part No.	
51	Insulate bushing	REE-045-0	
52 *	Heat sink	RNE-730-0	
53	Insulate bushing	REE-050-0	
54	Transistor board	RNP-153-0	
55 *	Tension arm bracket assembly	RXA-382-A	
56	Tension arm damper	REB-103-A	
57 *	Tension arm shaft	RLA-308-0	
58 *	Tension arm cam assembly	RXA-360-A	
59	Tension arm spring	RBH-149-A	
60	Shut-off switch P.C. board assembly	RWX-047-0	
61	Microswitch (shut-off switch)	RSF-013-0	
62	Counter	RAW-017-0	
63 *	Counter bracket	RNE-394-0	
64	Pinch backward spring	RBH-170-0	
65 *	Pinch arm shaft	RLA-307-0	
66 *	Pinch arm (B)	RNG-031-A	
67	Washer 6φ BN1	B22-426-0	
68	Rubber washer (A)	REB-052-0	
69	Felt	RED-069-0	
70	Capstan holder assembly	RXA-307-0	
71	Washer 6φ BN2	B22-425-0	
72	Fly wheel assembly	RXX-105-0	
73	Flywheel belt	REB-108-0	
74	Nylon ball	N23-608-A	
75 *	Flywheel bracket	RNE-475-A	
76	Frequency change switch	RSH-013-0	
77	Terminal strip 6P	RKC-013-0	FV model
78 *	Terminal strip mounting metal	RNE-652-A	
79 *	Motor chassis	RNE-702-0	
80	MP capacitor (A)2.8 + 1μF 250V	RCL-015-0	
81	Drive pulley (2)	RLA-346-0	NOTE 2
82	Capstan motor	RXM-012-0	
83	Motor fan	RNC-072-0	
84	Washer 4φ BN1	B22-422-0	
①	Playback head assembly	RXX-151-0	Including key No.14,12,8,7
②	Recording head assembly	RXX-152-0	Including key No.10,8,7
③	Pinch solenoid assembly	RXX-154-0	Including key No.29 ~ 35
④	Transistor P.C. board assembly	RWX-057-A	Including key No.50 ~ 54

NOTE 1:

There are three different kinds in thickness of erase head-adjustable spacer as follows:

REF-004-0	E.H. adj. spacer (A)	t = 0.1 mm
REF-005-0	E.H. adj. spacer (B)	t = 0.2 mm
REF-006-0	E.H. adj. spacer (C)	t = 0.3 mm

NOTE 2:

Tape speed-adjustable drive pulley is available in three different kinds as follows:

RLA-345-0 (1)	slightly small drive pulley in diam.
RLA-346-0 (2)	standard-size drive pulley in diam. (standard speeds)
RLA-347-0 (3)	slightly large drive pulley in diam.

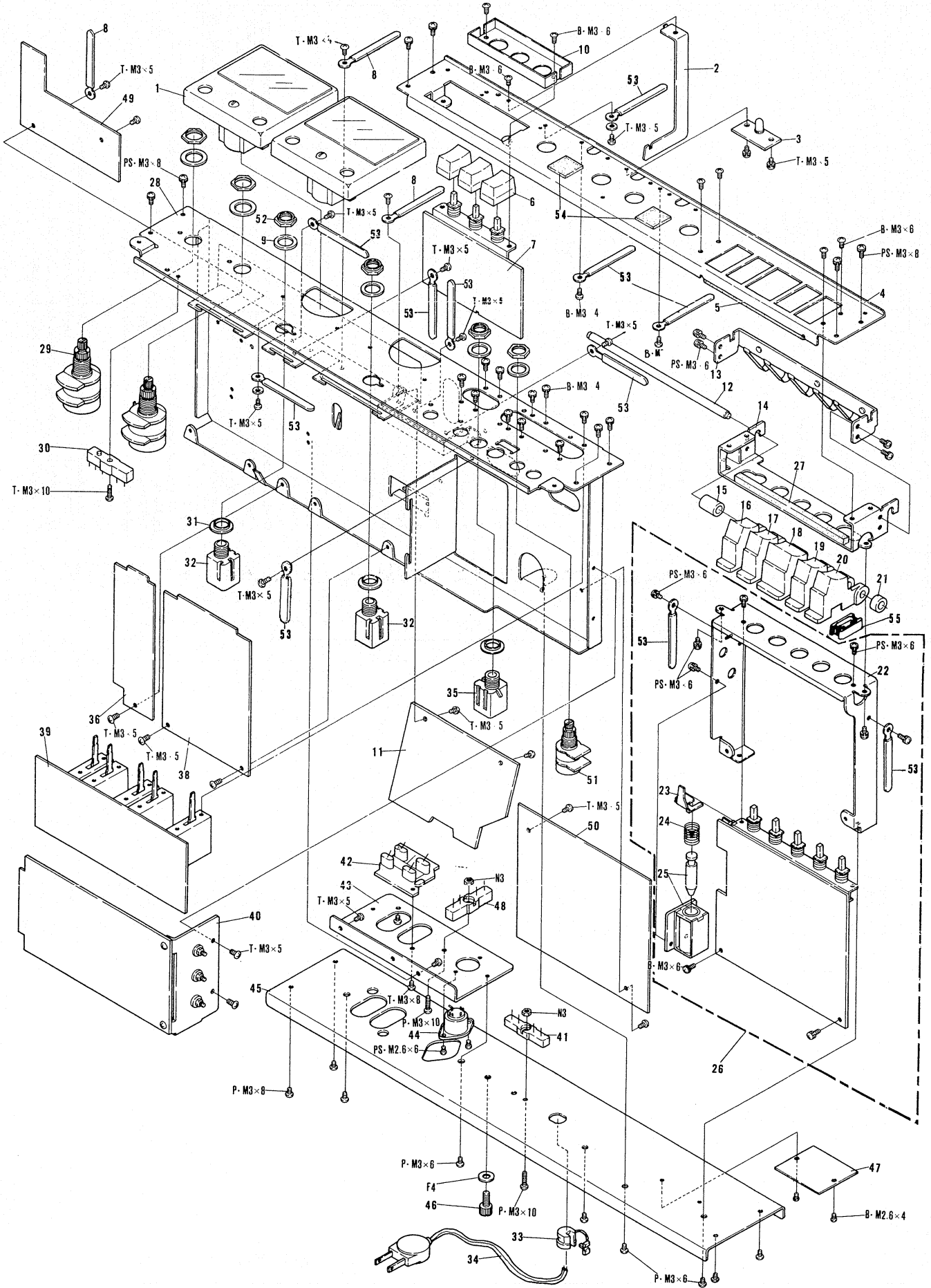



NOTICE: Any parts asterisked (\*) are subject to being not supplied.

NOTICE: Any parts asterisked (\*) are subject to being not supplied.

Key No.	Description	Part No.	
1	Level meter	RAW-018-0	
2 *	P.C. board holder	RNE-537-A	
3	REC lamp P.C. board assembly	RWX-058-0	
4 *	Control chassis	RNB-060-0	
5	Buffer felt	RED-052-0	
6	Knob (power, reel, speed)	RAC-004-A	
7	EQ switch circuit assembly	RWS-026-A	KU model
	EQ switch circuit assembly	RWS-027-B	FV model
8 *	Cord fixer (B)	RNE-605-0	
9	Insulate washer	E34-004-0	
10 *	Safety angle (A)	RNE-700-0	
11	Fuse P.C. board assembly	RWX-061-A	
12 *	Function button shaft	RLA-310-A	
13	Button spring assembly	RXA-316-A	
14 *	Button frame	RNE-409-A	
15 *	Button spacer (B)	RLP-003-A	
16	Function button (C) assembly (REC)	RXX-145-0	including key No. 55
17	Function button (B) assembly (REW)	RXX-144-0	including key No. 55
18	Function button (A) assembly (STOP)	RXX-143-0	including key No. 55
19	Function button (B) assembly (PLAY)	RXX-144-0	including key No. 55
20	Function button (B) assembly (FF)	RXX-144-0	including key No. 55
21 *	Button spacer (A)	RLP-002-0	
22 *	Function switch bracket	RNE-412-A	
23 *	Release plate	RNE-404-B	
24	Release spring	RBH-152-0	
25	Reset solenoid	RXP-019-A	
26	Control assembly	RWG-047-0	KU model
	Control assembly	RWG-046-0	FV model
27	Button felt	RED-066-0	
28 *	AMP chassis	RNB-057-0	
29	REC level volume	RCV-010-B	
30	Terminal strip 2p	AKC-023-0	
31	Insulate washer	E32-045-0	
32	MIC jack	RKN-020-0	
33	Power cord clamp	REC-164-0	
34	Power cord	ADG-004-0	FV model
	Power cord	D11-003-E	KU model
35	Headphone jack (A)	RKN-021-0	
36	P.B. amplifier assembly	RWF-028-0	
37	.....	.....	
38	REC amplifier assembly	RWF-029-0	
39	SW circuit assembly	RWS-024-0	
40	OSC assembly	RWA-021-0	
41	Terminal strip 2p	AKC-023-0	
42	4P pin jack	AKB-014-0	
43 *	Pin jack mounting bracket	RNE-736-0	
44	DIN socket	RKP-006-0	
45 *	Rear panel	RNA-167-0	

Key No.	Description	Part No.	
46	Binding post	B11-012-A	
47 *	Name plate	RAL-150-0	KU model
	Name plate	RAL-151-0	FV model
48	Terminal strip 2P	AKC-023-0	
49 *	Insulate plate (A)	REC-174-0	
50 *	Insulate plate (B)	REC-175-0	
51	Playback level volume	RCV-019-0	
52	Insulate nut	RBN-004-A	
53 *	Cord fixer (B)	RNE-613-0	
54 *	Motor cushion	RED-067-A	
55	Button holder	REC-167-A	

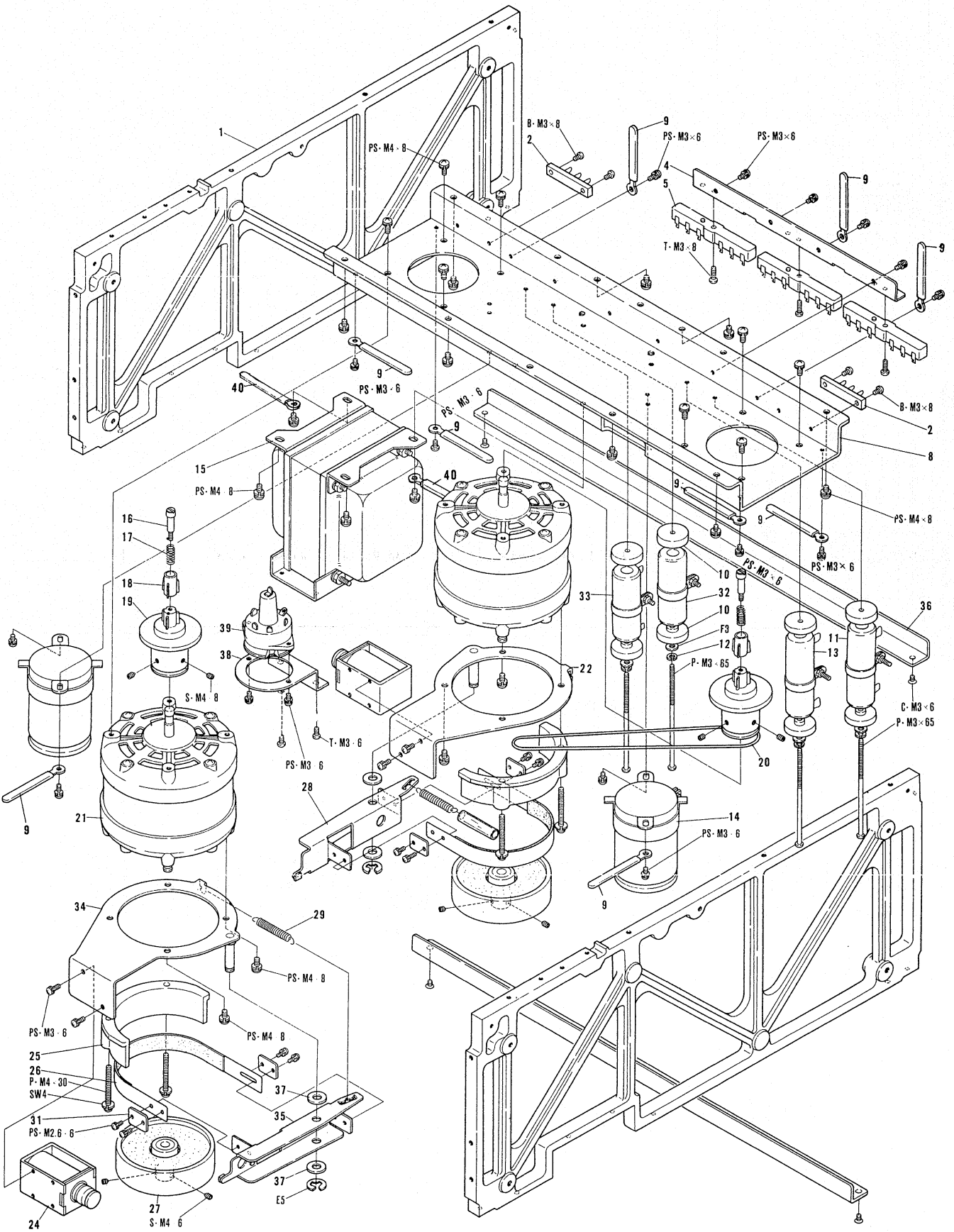

# RT-1011L

NOTICE: Any parts asterisked (\*) are subject to being not supplied.

Key No.	Description	Part No.	
1 *	Chassis frame	RNG-036-D	
2	Melded terminal T-type 3P	RKC-016-0	
3	.....	.....	
4 *	Terminal mounting plate	RNE-478-0	
5	Terminal strip 6P	RKC-013-0	
6	.....	.....	
7	.....	.....	
8 *	Reel chassis	RNB-053-0	
9 *	Cord fixer (B)	RNE-513-0	
10	Bushing	RBF-019-0	
11	Wire wound resistor (B)	RCN-021-0	
12	Special spring washer 3φ		
13	Wire wound resistor (C)	RCN-022-0	
14	Phase capacitor 0.5+4μF 250V	RCL-010-0	
15	Power transformer	RTT-048-A	FV model
	Power transformer	RTT-057-A	KU model
16	Reel base screw	RLA-321-0	
17	Reel base spring	RBH-162-0	
18	Reel feather shaft	RNG-051-A	
19	Reel base	RNG-055A	
20	Counter belt	REB-077-0	
21	Reel motor	RXM-017-0	
22 *	Brake plate (R) assembly	RXA-508-0	
23	.....	.....	
24	Brake solenoid	RXP-022-0	
25 *	Brake guide	RNK-111-B	
26	Brake band assembly	RXX-111-0	
27	Brake drum assembly	RXX-110-0	
28 *	Brake arm (R)	RNE-724-0	
29	Brake spring	RBH-173-0	
30	.....	.....	
31	Brake adjustment plate	RNE-401-A	
32	Wire wound resistor (D)	RCN-023-0	
33	Wire wound resistor (A)	RCN-020-0	
34 *	Brake plate (L) assembly	RXA-509-0	
35 *	Brake arm (L)	RNE-723-0	
36 *	Stiffen angle	RNC-068-0	
37	Washer 6φ BN1	B22-426-0	
38 *	Switch mounting plate	RNE-740-0	FV model
39	Line voltage selector switch	AKR-027-0	FV model
40 *	Cord fixer (B)	RNE-513-0	FV model

## 11. 5 PACKING

NOTICE: Any parts asterisked (\*) are subject to being not supplied.

Key. No	Description	Part No.	
1 *	Packing case assembly	RHK-131-0	
1-1	Outer case	RHG-072-0	
1-2	Cardboard	RHC-028-0	
1-3	Spacer	RHC-029-0	
1-4	Side spacer	RHC-030-0	
5	Cushion (L)	RHA-082-0	
6	Cushion (R)	RHA-083-0	
7 *	Metal reel 10-1/2 in		
8	Furnished parts		
	Cardboard	RHC-031-0	
	Vinyl bag	RHL-025-0	
	Reel adaptors	RXX-149-0	
	Reel adjusting sheets	REB-119-0	
	Connection cord	RDE-010-A	
	Cleaning kit	REA-005-0	
	Splicing tape	P45-851-0	
	Cleaning ribbon	E33-856-0	
	Vinyl bag	REG-010-0	
9 *	Packing sheet	RHC-023-0	
10	Operating instructions	RRB-041-A	KU model
	Operating instructions	RRB-046-0	FV model
	Operating instructions (German/Franch)	RRD-008-0	FV model
11	Protector	RHC-027-0	
12	Ribbon	RED-068-0	
13	Vinyl bag	RHL-021-0	





## 12. LEVEL DIAGRAM

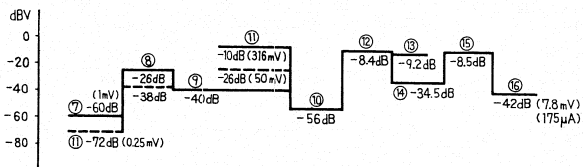
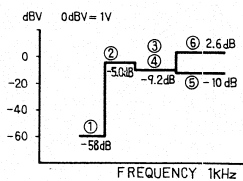
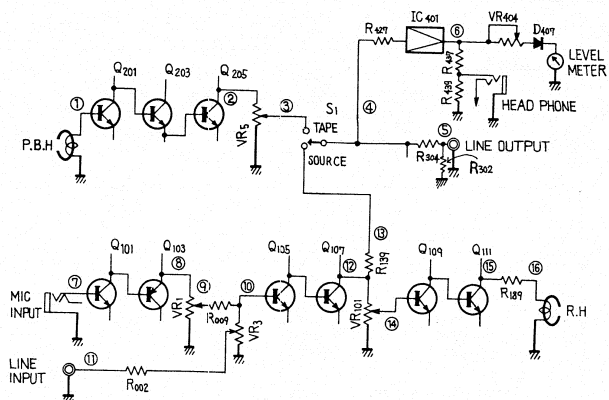

**PIONEER ELECTRONIC CORPORATION**  
 4-1, 1-Chome, Meguro, Meguro-ku, Tokyo 153, Japan  
**U.S. PIONEER ELECTRONICS CORPORATION**  
 75 Oxford Drive, Moonachie, New Jersey 07074, U.S.A.  
**PIONEER ELECTRONIC (EUROPE) N.V.**  
 Meir-Center, Meer 21, 2000 Antwerp, Belgium  
**PIONEER ELECTRONICS AUSTRALIA PTY. LTD.**  
 256-B City Road, South Melbourne, Victoria 3205, Australia