

# TC-366

General Export Model

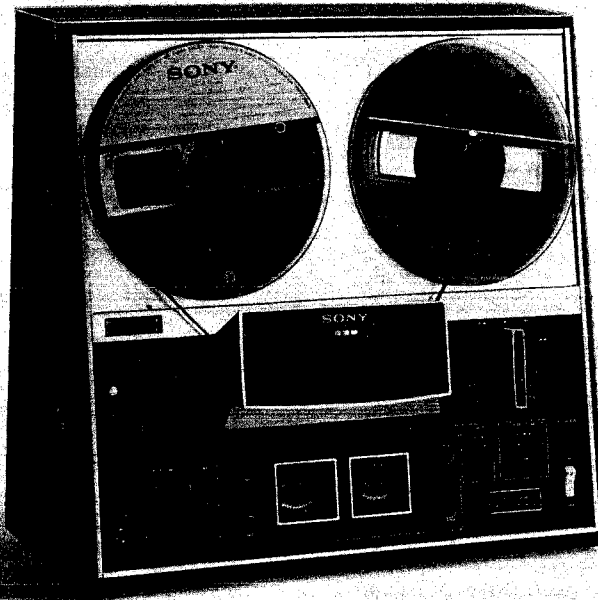

Set using ISO screws

## SPECIFICATIONS

<b>Power Requirements:</b>	AC 50/60 Hz, 100V, 110V, 117V, 125V, 220V and 240V, 20W	<b>REC/PB connector</b>	Impedance: 10 k $\Omega$ Maximum sensitivity: -33dB (17mV)												
<b>Track System:</b>	Four-track stereo and mono	<b>Outputs:</b>	Two LINE OUTputs Impedance: 100 k $\Omega$ or more Output level: 0dB (0.775V) with 100 k $\Omega$ load												
<b>Reel Size:</b>	7" (18 cm) maximum	<b>REC/PB connector</b>	Impedance: 100 k $\Omega$ load Output level: -2~-6dB (0.62~0.385V)												
<b>Tape Speed:</b>	7 1/2 ips, 3 3/4 ips and 1 7/8 ips (19 cm/s, 9.5 cm/s and 4.8 cm/s)	<b>HEAD PHONE output</b>	Impedance: 8 $\Omega$ load Output level: -28dB (30mV)												
<b>Recording Time:</b> (with 1,800 ft tape)	<table><thead><tr><th>Tape speed</th><th>4-track stereo</th><th>4-track mono</th></tr></thead><tbody><tr><td>7 1/2 ips (19 cm/s)</td><td>1.5 hrs</td><td>3 hrs</td></tr><tr><td>3 3/4 ips (9.5 cm/s)</td><td>3 hrs</td><td>6 hrs</td></tr><tr><td>1 7/8 ips (4.8 cm/s)</td><td>6 hrs</td><td>12 hrs</td></tr></tbody></table>	Tape speed	4-track stereo	4-track mono	7 1/2 ips (19 cm/s)	1.5 hrs	3 hrs	3 3/4 ips (9.5 cm/s)	3 hrs	6 hrs	1 7/8 ips (4.8 cm/s)	6 hrs	12 hrs	<b>Semiconductors:</b>	27 transistors and 4 diodes
Tape speed	4-track stereo	4-track mono													
7 1/2 ips (19 cm/s)	1.5 hrs	3 hrs													
3 3/4 ips (9.5 cm/s)	3 hrs	6 hrs													
1 7/8 ips (4.8 cm/s)	6 hrs	12 hrs													
<b>Frequency Response:</b>	20~25,000 Hz at 7 1/2 ips (19 cm/s) 30~17,000 Hz at 3 3/4 ips (9.5 cm/s) 30~9,000 Hz at 1 7/8 ips (4.8 cm/s)	<b>Dimensions:</b>	16 7/16 (W) x 8 5/16 (H) x 14 3/16" (D) (416 x 210 x 376 mm)												
<b>Signal-to-Noise Ratio:</b>	52 dB or better (at peak level recording)	<b>Weight:</b>	22 lb 8 oz (10 kg)												
<b>Flutter and Wow:</b>	0.09% at 7 1/2 ips (19 cm/s) 0.12% at 3 3/4 ips (9.5 cm/s) 0.17% at 1 7/8 ips (4.8 cm/s)														
<b>Recording Bias Frequency:</b>	Approx. 160 kHz														
<b>Inputs:</b>	Two MIC inputs Impedance: 600 $\Omega$ Maximum sensitivity: -72 dB (0.19 mV) Two AUX inputs Impedance: Approx. 100 k $\Omega$ Maximum sensitivity: -22 dB (0.06 V)														

**SONY**<sup>®</sup>  
**SERVICE MANUAL**

## TABLE OF CONTENTS

<u>Title</u>	<u>Page</u>	<u>Title</u>	<u>Page</u>
<b>SPECIFICATIONS</b> .....	1	11. MECHANICAL ADJUSTMENT .....	16 ~ 24
1. GENERAL DESCRIPTION .....	2	12. ELECTRICAL ADJUSTMENT .....	25 ~ 39
2. BLOCK DIAGRAM .....	2	13. CONVERSION TO DIFFERENT	
3. CABINET - TOP VIEW - .....	3	POWER LINE FREQUENCY .....	40
4. CABINET - SIDE VIEWS - .....	3	14. ELECTRICAL PARTS LIST .....	41 ~ 43
5. CHASSIS - TOP VIEW - .....	4	15. EXPLODED VIEW	
6. CHASSIS - BOTTOM VIEW - .....	4	15-1. Packing .....	44
7. DISASSEMBLY .....	5 ~ 6	15-2. Cabinet - top view - .....	45
8. SCHEMATIC DIAGRAM .....	7 ~ 8	15-3. Amplifier Chassis - top view (1) .....	46
9. MOUNTING DIAGRAM		15-4. Amplifier Chassis - top view (2) - .....	47 ~ 48
9-1. Record Amplifier Circuit Board .....	9 ~ 10	15-5. Head Deck - top view - .....	49 ~ 50
9-2. Playback Amplifier Circuit Board .....	11 ~ 12	15-6. Chassis - top view (1) - .....	51 ~ 52
9-3. Bias Oscillator Circuit Board .....	13	15-7. Chassis - top view (2) - .....	53 ~ 54
9-4. Power Supply Circuit Board .....	14	16. HARDWARES .....	55
10. LEVEL DIAGRAM .....	15	Hardware Nomenclature .....	55

### 1. GENERAL DESCRIPTION

The SONY Model TC-366 which is the one-motor, three-head stereo deck type tape recorder equips with the following features;

#### Tape Tension Regulator

The machine can operate always under the stable tape running by the tape tension regulator which quickly responds to the subtle change of tape tension, so that the tape tension regulator can reduce the wow and flutter extremely.

### 2. BLOCK DIAGRAM

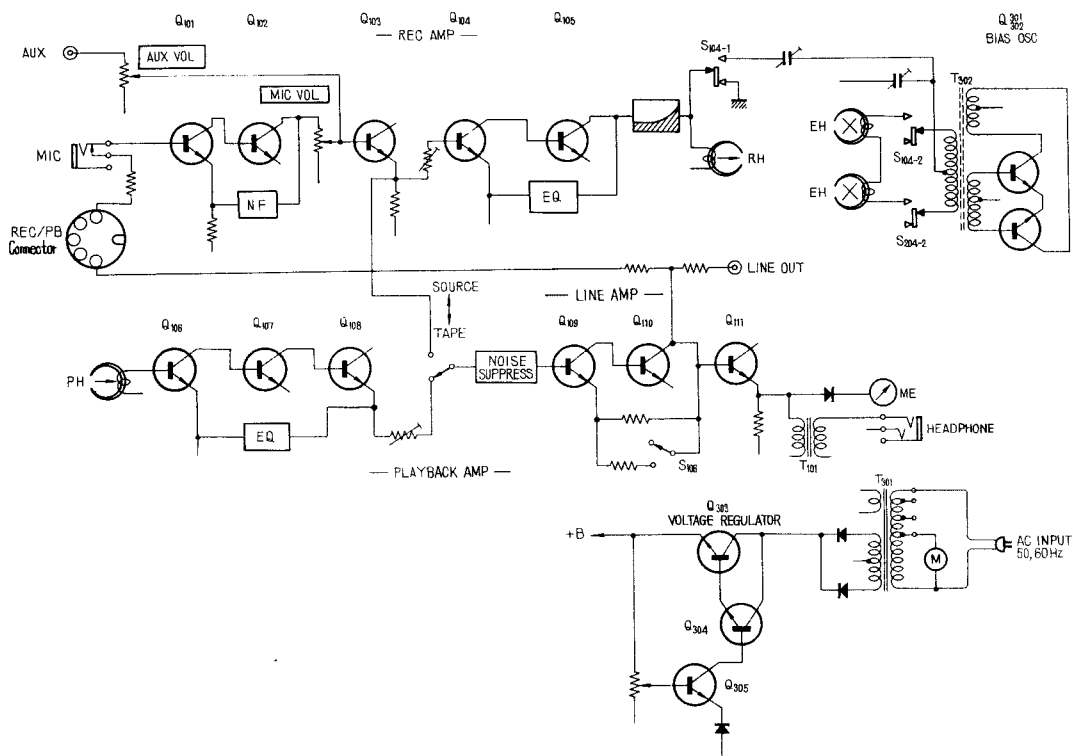

#### Automatic Shut-off Mechanism

When threading the tape, the shut-off lever is held by the threaded tape in operating position. If tape runs out or breaks, the shut-off lever swings outward and activates the automatic shut-off mechanism. As a result, the function selector knob can return to the STOP position without setting it manually.

**Note:** When threading the tape, make certain that there is no slack in the threaded tape, otherwise the function selector knob will not be set at the desired position.

**3. CABINET – TOP VIEW –**

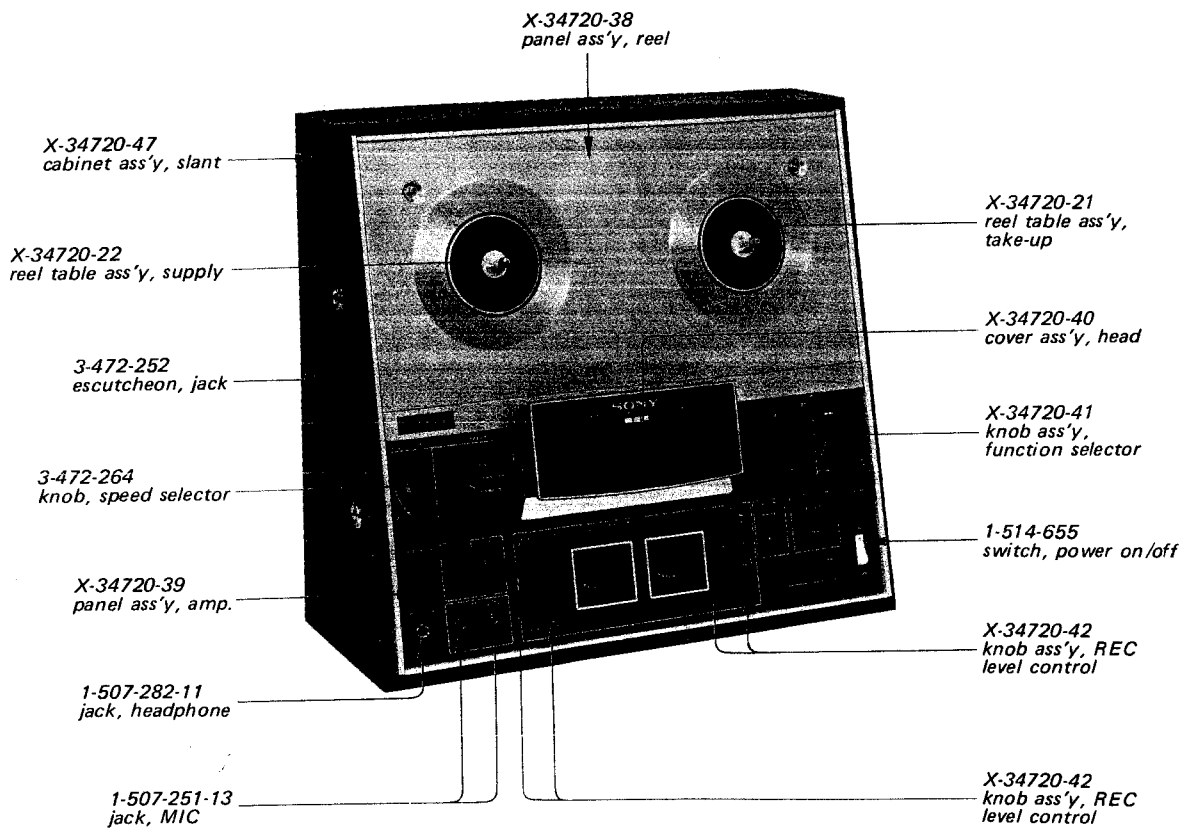

**4. CABINET – SIDE VIEWS –**

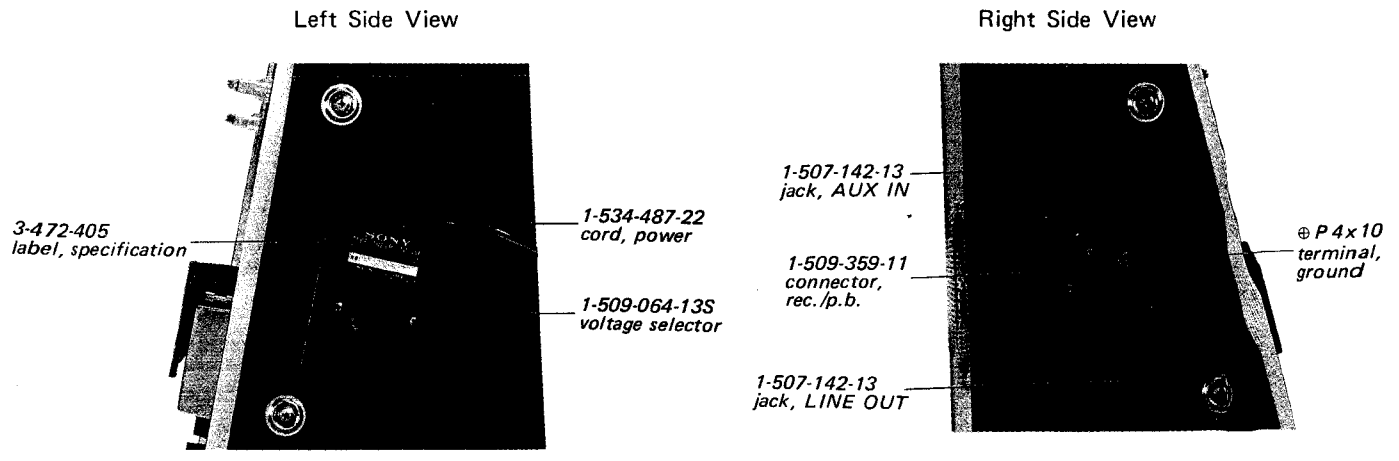

**5. CHASSIS – TOP VIEW –**

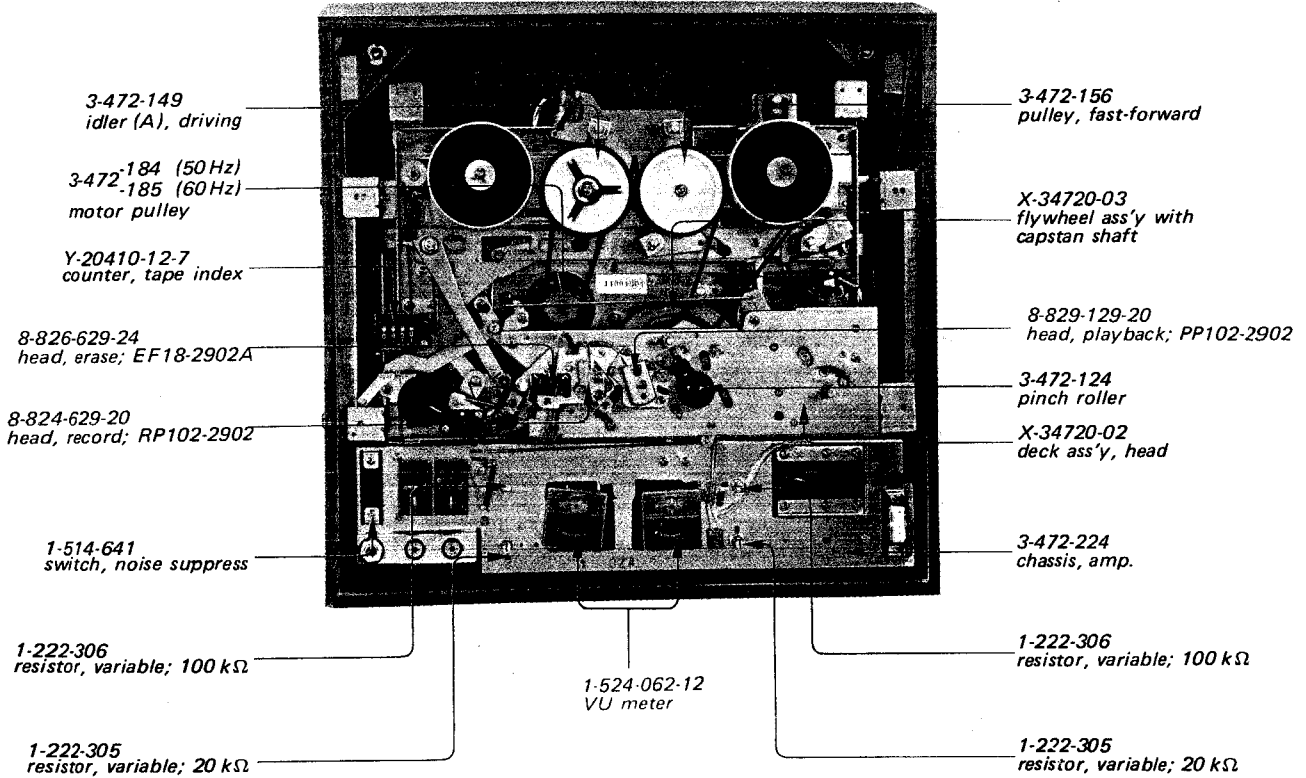

**6. CHASSIS – BOTTOM VIEW –**

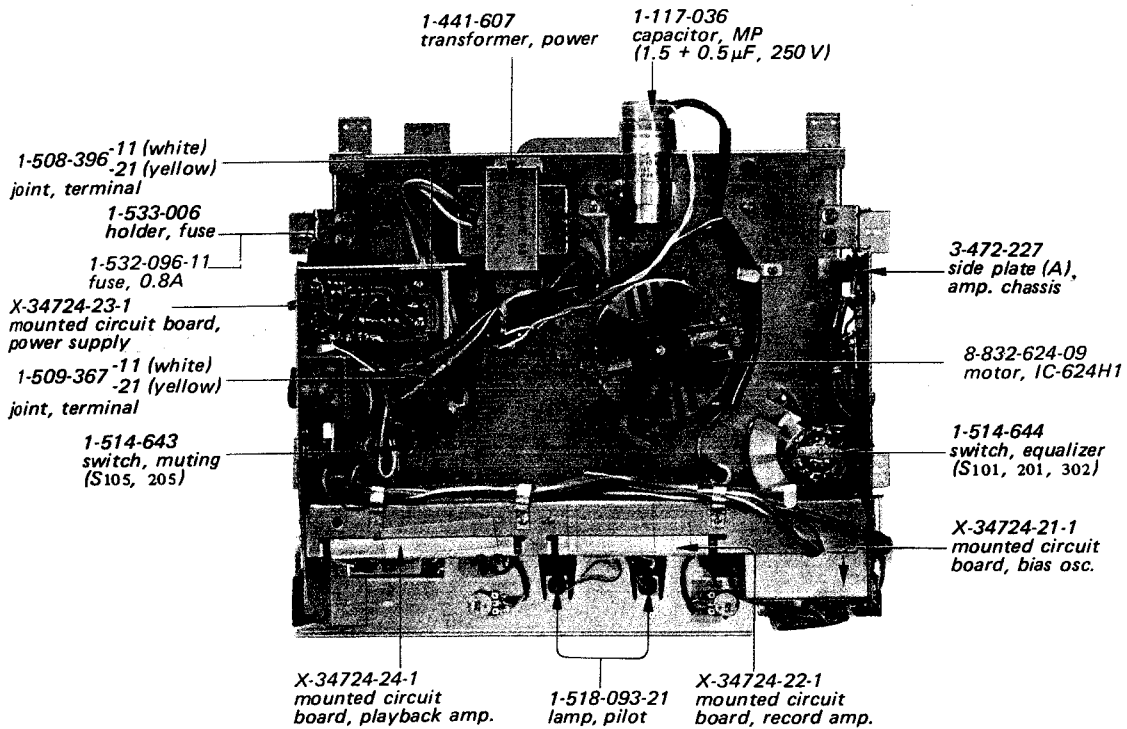

**7. DISASSEMBLY**

**7-1. Reel Panel Removal**

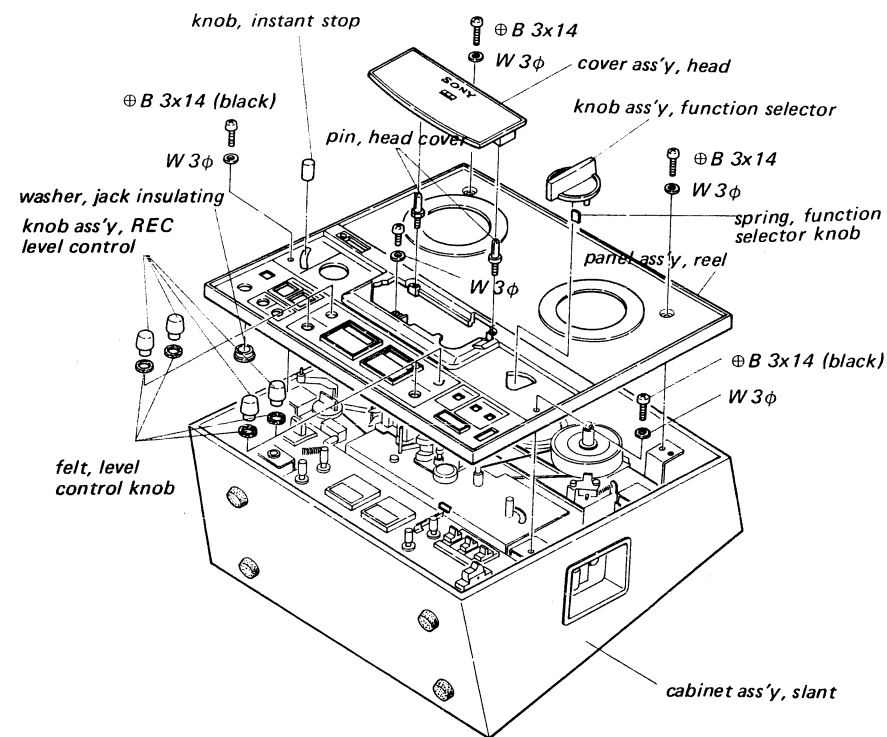

**7-2. Chassis and Bottom Cover Removal**

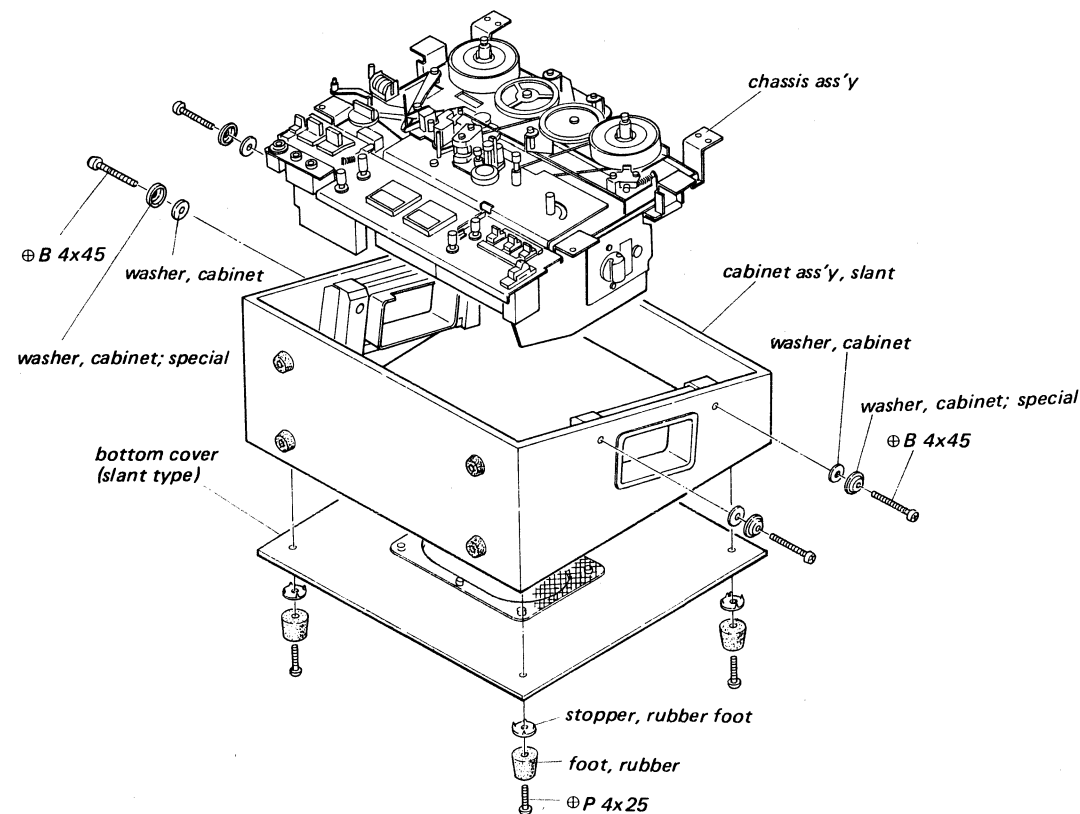

**CAUTION**  
(on cabinet reassembling)

- (1) Be sure that the tab of the reel panel is inserted in the hole of the amp. chassis as shown in Fig. 7-1.
- (2) When attaching the cabinet to the chassis, be certain that the reel tables, the jacks and the switches are set correctly in the respective holes of the reel panel, and then fix the four screws alternately.
- (3) When attaching the reel panel to the cabinet, it is convenient to attach tentatively the two level meters to reel panel with adhesive tape.

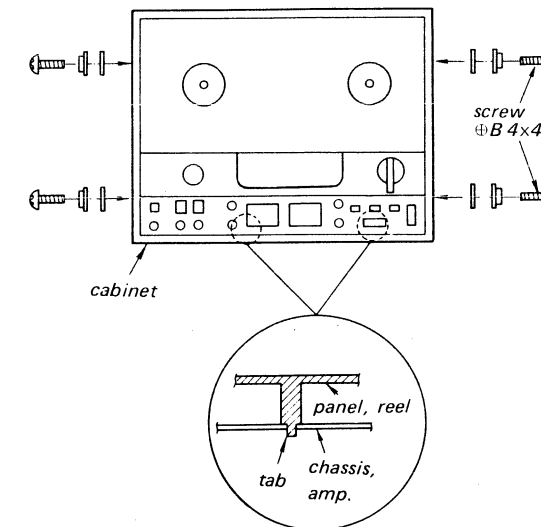
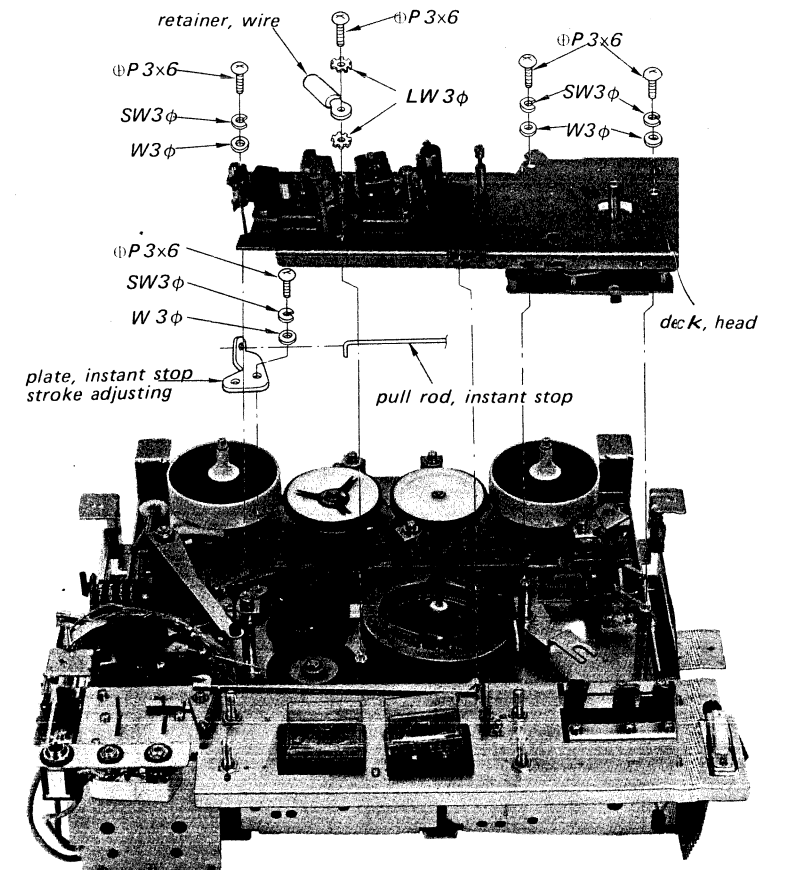

Fig. 7-1 Reel panel removal

**CAUTION**  
(on repairing)

- (1) Never put the machine upside-down on the hard plate with the head cover removed, or the pin of the tape shifter, the shut-off arm pin, the tension arm and others shall be bent by the weight of the machine.  
If it is necessary to put the machine upside-down put it on a soft cloth with the head cover attached.
- (2) Do not short-circuit B<sup>+</sup> circuit to ground, or the transistor Q304 will be broken.
- (3) When removing the instant stop knob, turn it clockwise.
- (4) Turn on the power switch after being certain that the motor fan does not touch anything.

**7-3. Head Deck Removal**



8. SCHEMATIC DIAGRAM

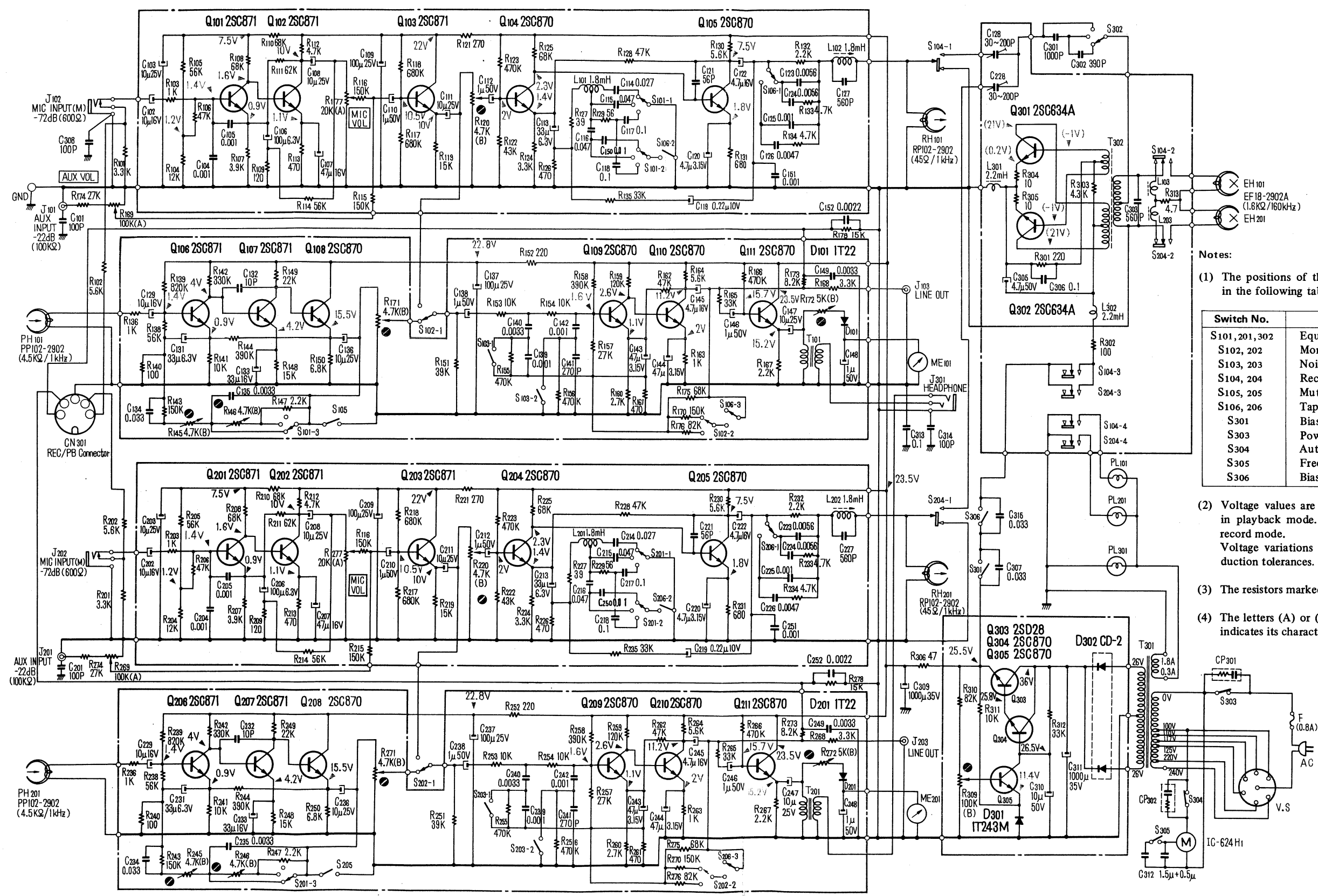

Notes:

- The positions of the switches in this schematic are shown in the following table.
- Voltage values are measured with a voltmeter (20 kΩ/V) in playback mode. Voltage values in parentheses are for record mode. Voltage variations may be noted because of normal production tolerances.
- The resistors marked  $\odot$  are semi-fixed resistor.
- The letters (A) or (B) which is suffixed to resistance value indicates its characteristics.

Switch No.	Description	Position
S101, 201, 302	Equalizer Switch	19 cm/s
S102, 202	Monitor Switch	Tape
S103, 203	Noise Suppress Switch	OFF
S104, 204	Record Switch	OFF
S105, 205	Muting Switch	OFF
S106, 206	Tape Selector Switch	Normal
S301	Bias ON/OFF Switch	OFF
S303	Power Switch	ON
S304	Automatic Shut-off Switch	ON
S305	Frequency Change Switch	60 Hz
S306	Bias Timing Switch	OFF

9. MOUNTING DIAGRAM

9-1. Record Amplifier Circuit Board

- Conductor Side -

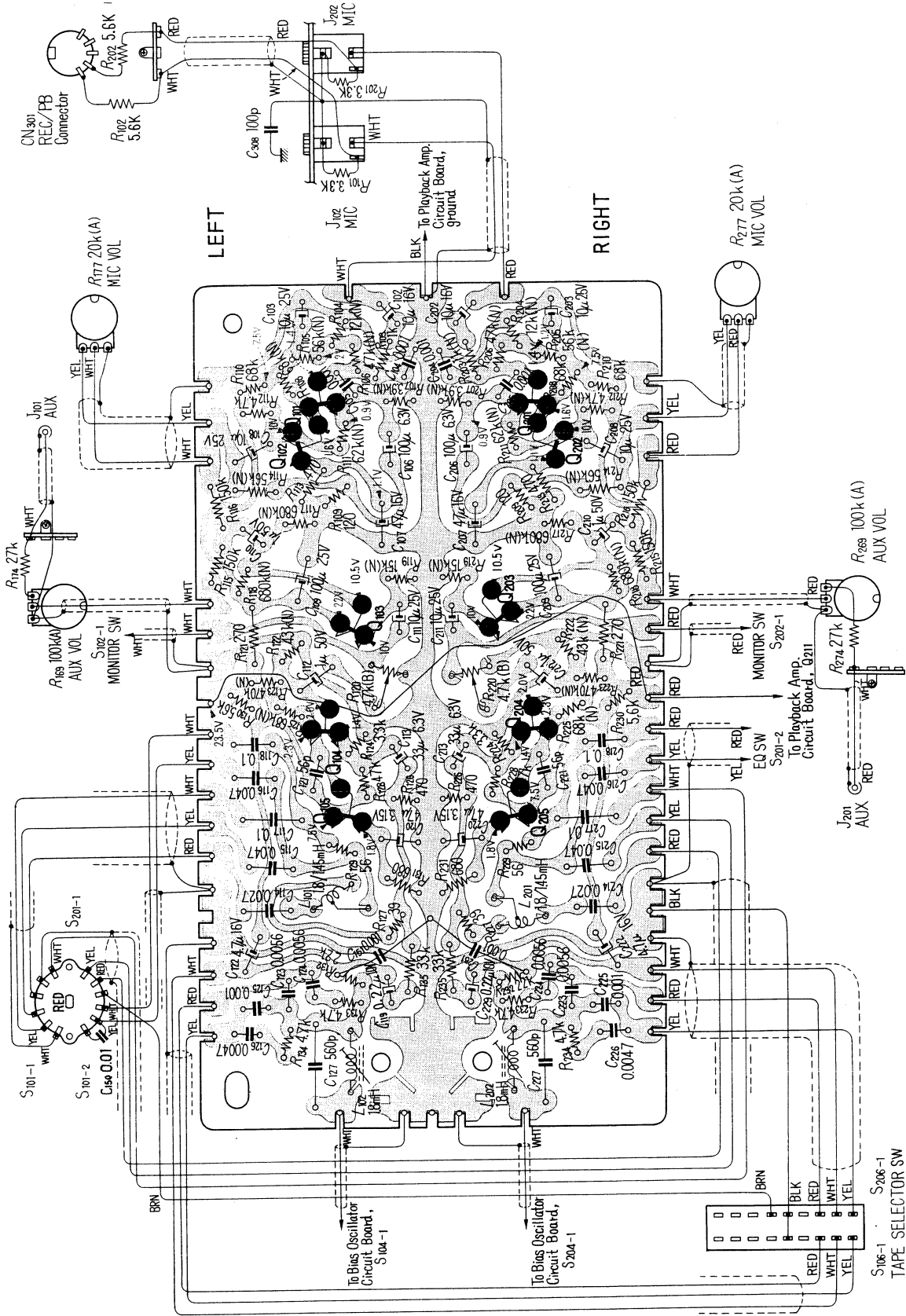

Printed Circuit Board  
Part No. 1-539-387-11

9-1. Record Amplifier Circuit Board

- Component Side -

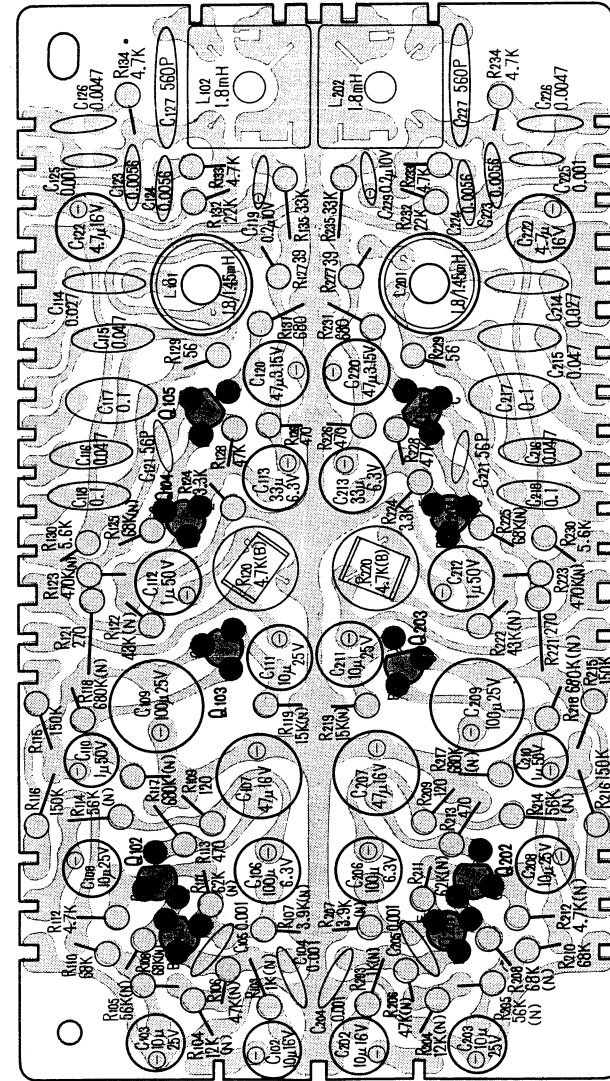

Q101~103 2SC871  
Q201~203  
Q104, 105 2SC870  
Q204, 205

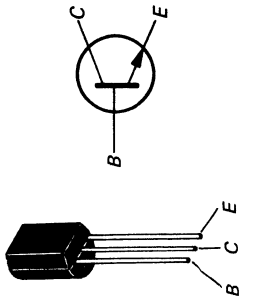



9-2. Playback Amplifier Circuit Board

- Conductor Side -

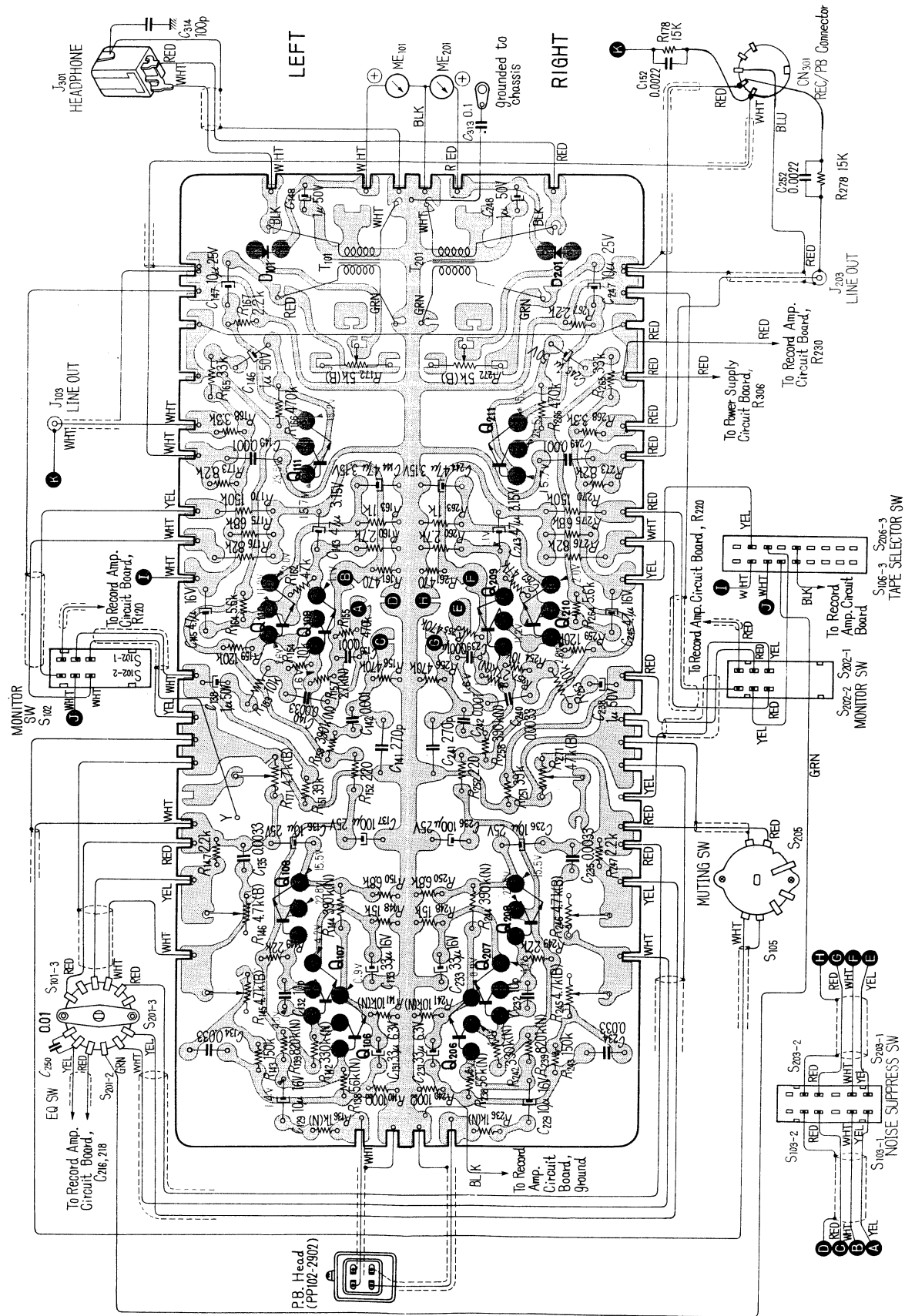

Printed Circuit Board  
Part No. 1-539-388-12

9-2. Playback Amplifier Circuit Board

- Component Side -

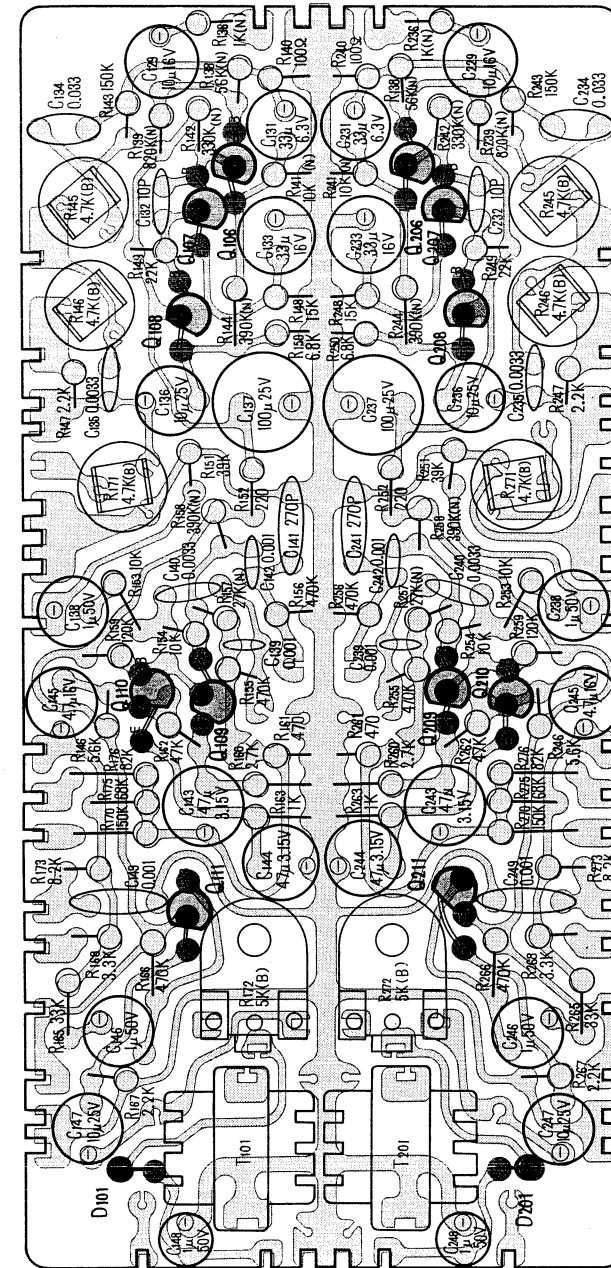

Q105, 107 2SC871  
Q206, 207  
Q108~111 2SC870  
Q208~211

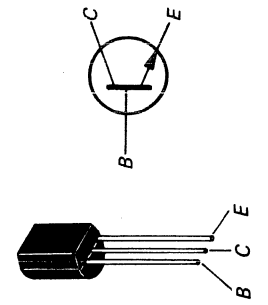

D101, 201 1T22

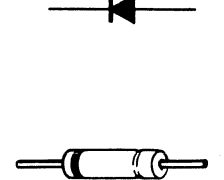



9-3. Bias Oscillator Circuit Board

— Component Side —

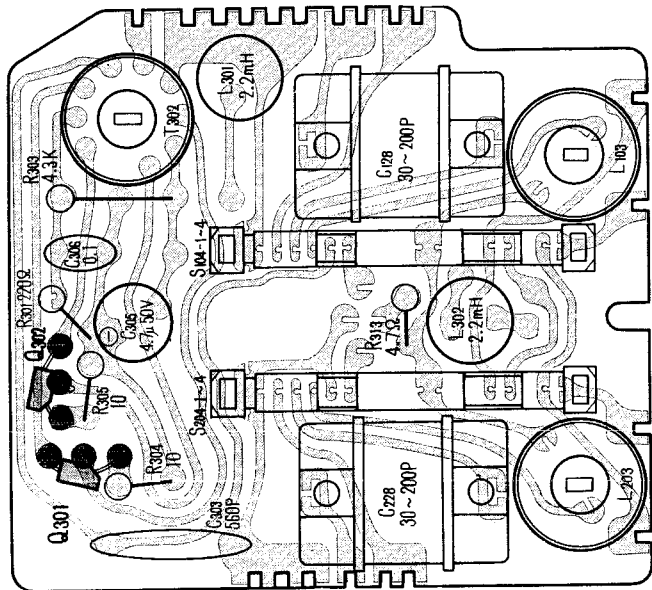

Q301, 302 2SC634A

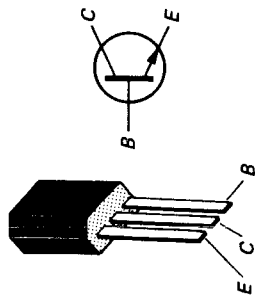

— Conductor Side —

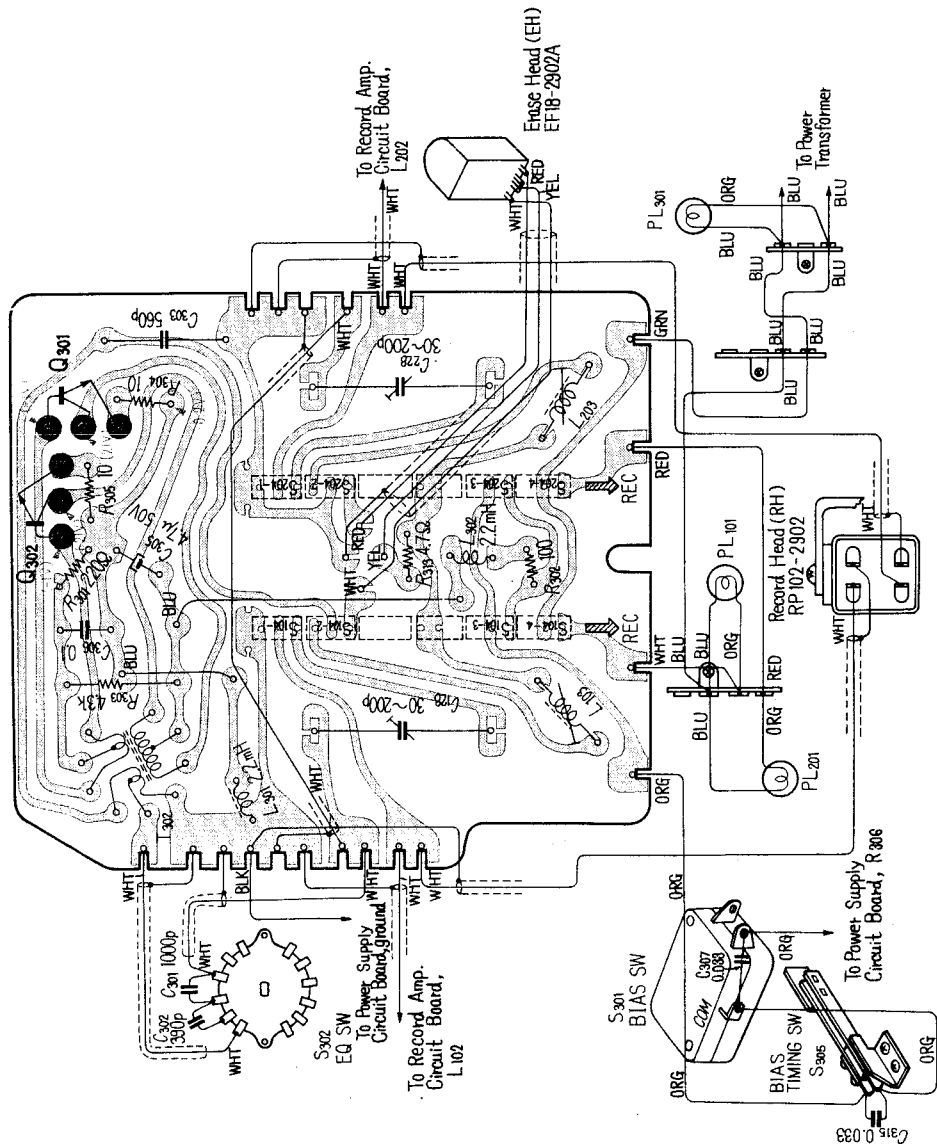

Printed Circuit Board  
Part No. 1-539-389-11

9.4. Power Supply Circuit Board

— Component Side —

— Conductor Side —

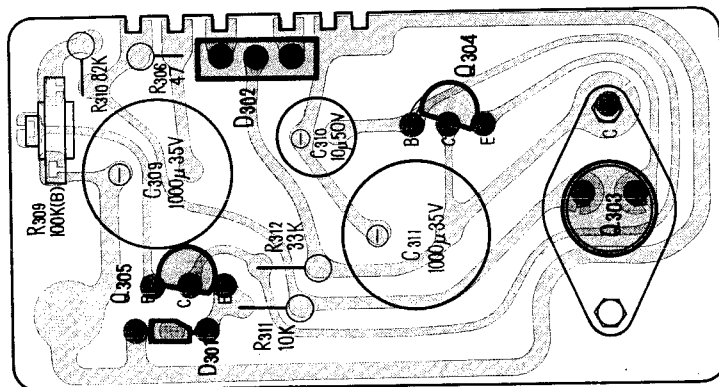
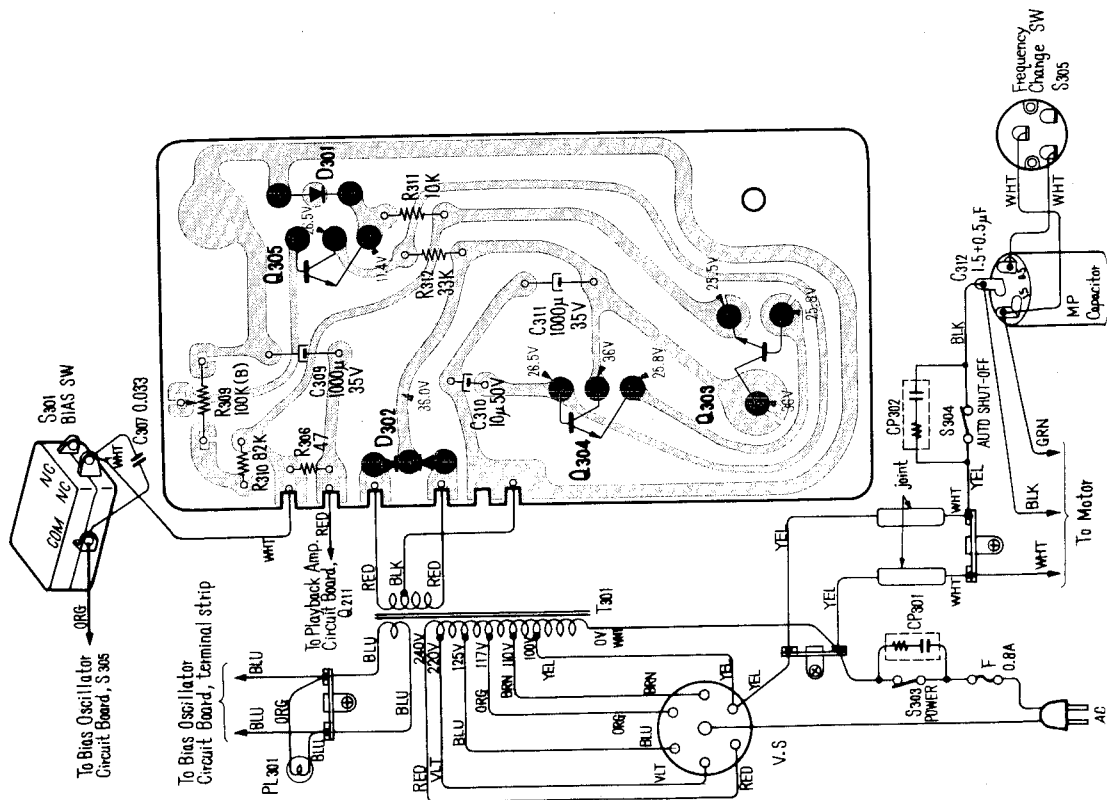

D301 1T243M

Diode

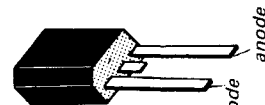

Q304, 305 2SC870



Q303 2SD28

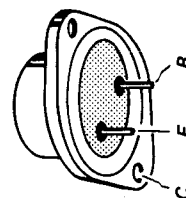

Printed Circuit Board  
Part No. 1-539-390-11

### 10. LEVEL DIAGRAM

#### 10-1. Record

0dB = 0.775V, f = 1kHz

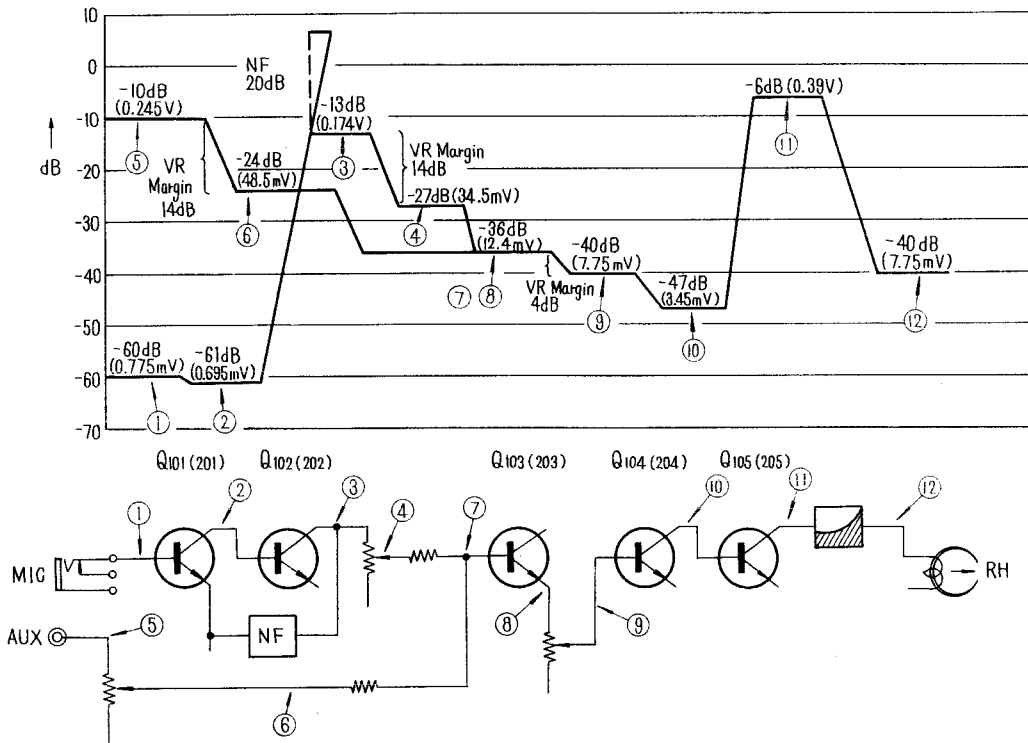

#### 10-2. Playback

0dB = 0.775V, f = 1kHz

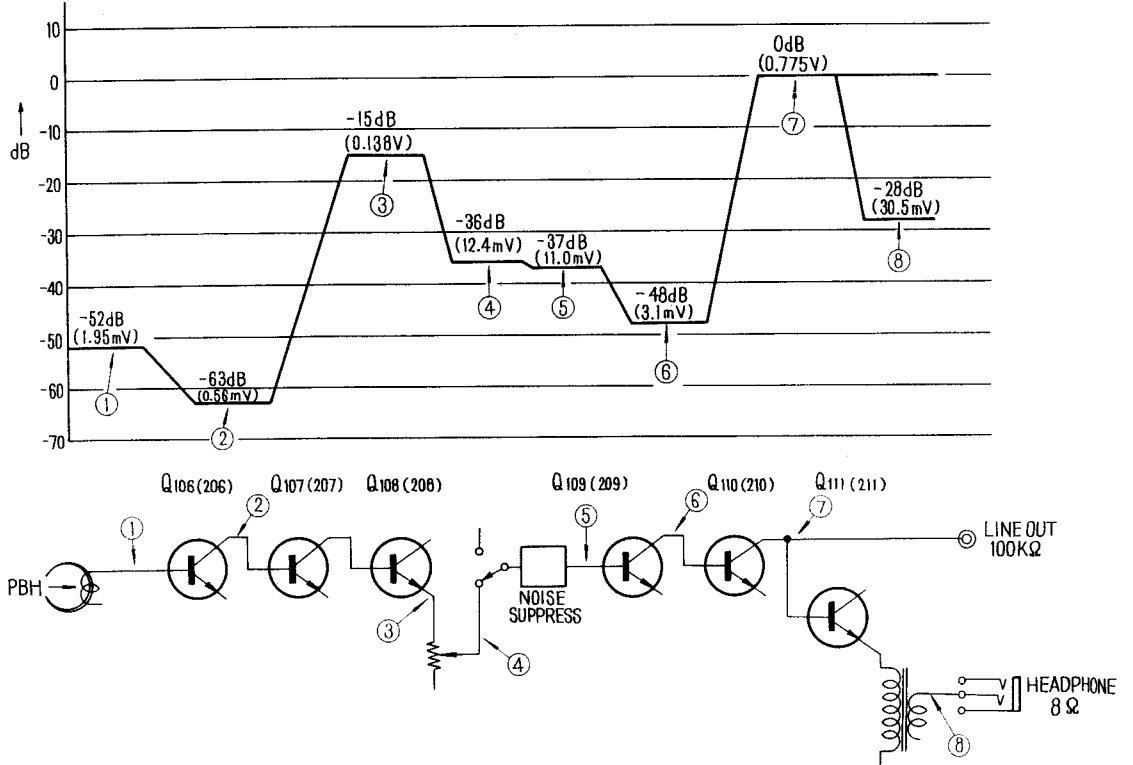

**11. MECHANICAL ADJUSTMENT**

In case the parts described in the table below are reassembled or replaced, the following adjustments and checks are necessary.

Parts	Adjusting or Checking Item
Head Deck	<ul style="list-style-type: none"> <li>• Tape Shifter Position Adjustment (See page 19)</li> <li>• Instant Stop Adjustment (See page 20)</li> <li>• Bias Timing Switch Check (See page 20)</li> <li>• Record Releasing Rod Adjustment (See page 23)</li> </ul>
Motor	<ul style="list-style-type: none"> <li>• Capstan Idler Position Adjustment (See page 21)</li> <li>• Tape Speed Adjustment (See page 24)</li> </ul>
Reel Table	<ul style="list-style-type: none"> <li>• Reel Table Height Adjustment (See page 21)</li> <li>• Take-up Back-tension Adjustment (See page 21)</li> <li>• FWD Torque Adjustment (See page 21)</li> </ul>
Driving Idler	<ul style="list-style-type: none"> <li>• FF &amp; REW Torque Adjustments (See page 23)</li> <li>• FF &amp; Driving Idler Height Adjustments (See page 23)</li> </ul>
Tension Regulator Arm	<ul style="list-style-type: none"> <li>• Tension Regulator Adjustment (See page 17)</li> </ul>
Tension Regulator Arm Felt	<ul style="list-style-type: none"> <li>• Tension Regulator Back-tension Adjustment (See page 18)</li> </ul>

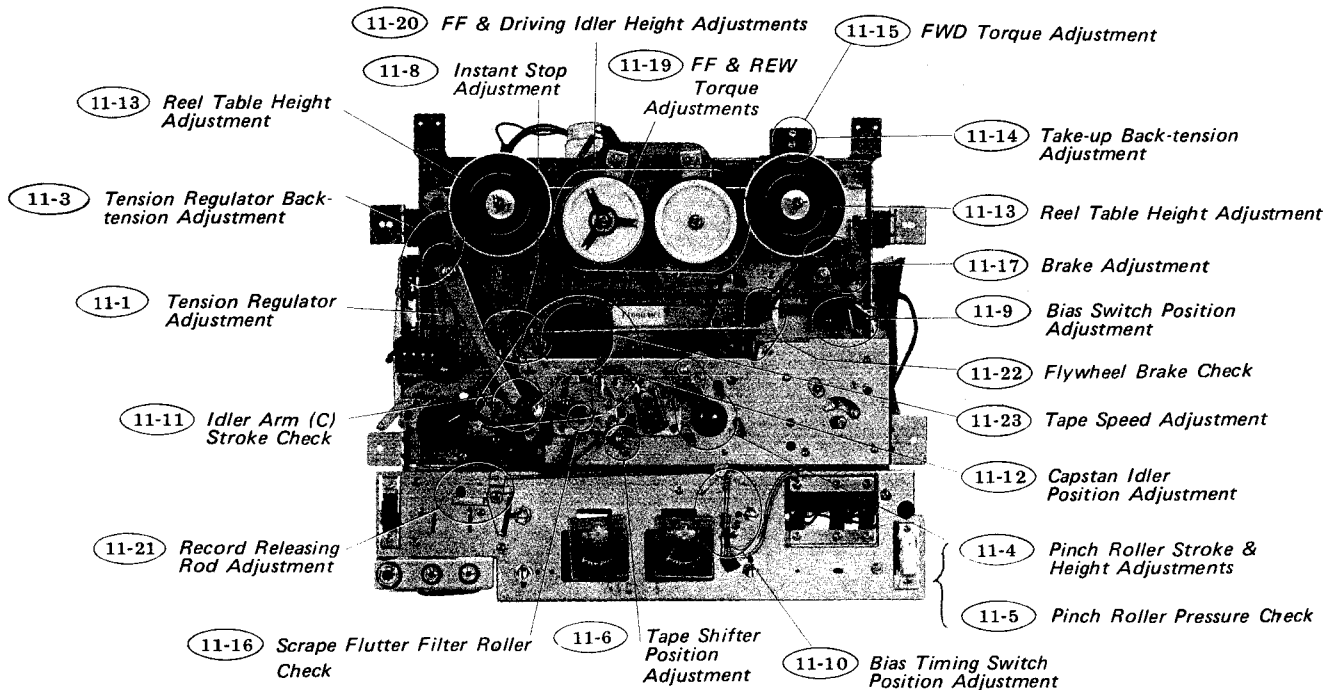

Fig. 11-1 Adjusting parts location (1)

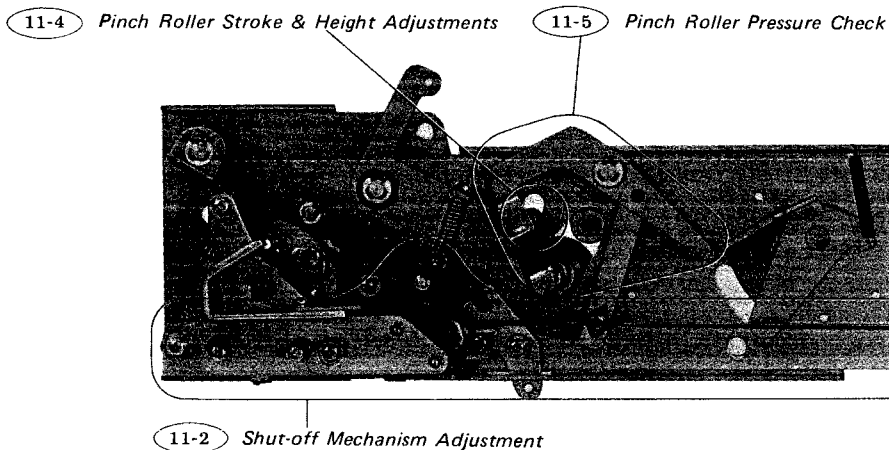

Fig. 11-2 Adjusting parts location (2)

11-1. Tension Regulator Adjustment

— in STOP mode —

- (1) Adjust the adjusting screw so that the clearance shown is 8.5mm ( $1\frac{1}{32}$ " ) after having been turned the reel table counterclockwise with hand.
- (2) After the adjustment, apply lock paint to the screw.

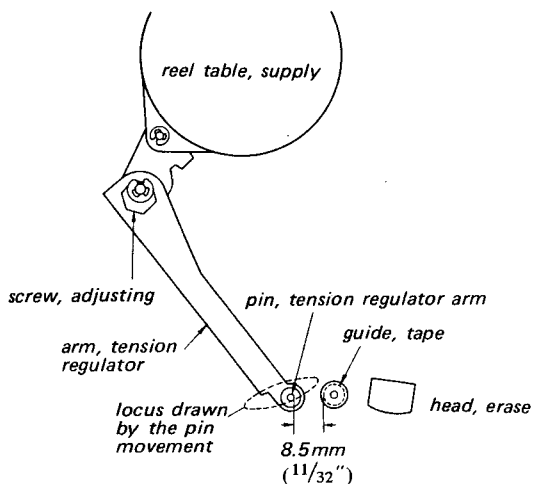
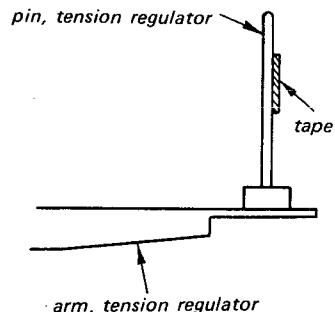

Fig. 11-3 Tension regulator adjustment



Be sure that the tape comes in contact with the tension regulator arm pin uniformly at the beginning and the end of the tape as shown.

Fig. 11-4 Tension regulator adjustment

11-2. Shut-off Mechanism Adjustment

— in STOP mode —

- (1) Loosen the two screws A and adjust by positioning the shut-off lever holding plate ass'y so that the shut-off mechanism is locked when the clearance between the shut-off arm and the head deck is 6mm ( $\frac{15}{64}$ " ), and the shut-off mechanism is released completely when it is 1mm ( $\frac{3}{64}$ " ).
- (2) Adjust the screw B so that the clearance between the shut-off levers (B) and (H) is 0.3~0.6mm ( $\frac{1}{64}$ " ) in STOP mode.
- (3) After the adjustment, apply lock paint to the screws.

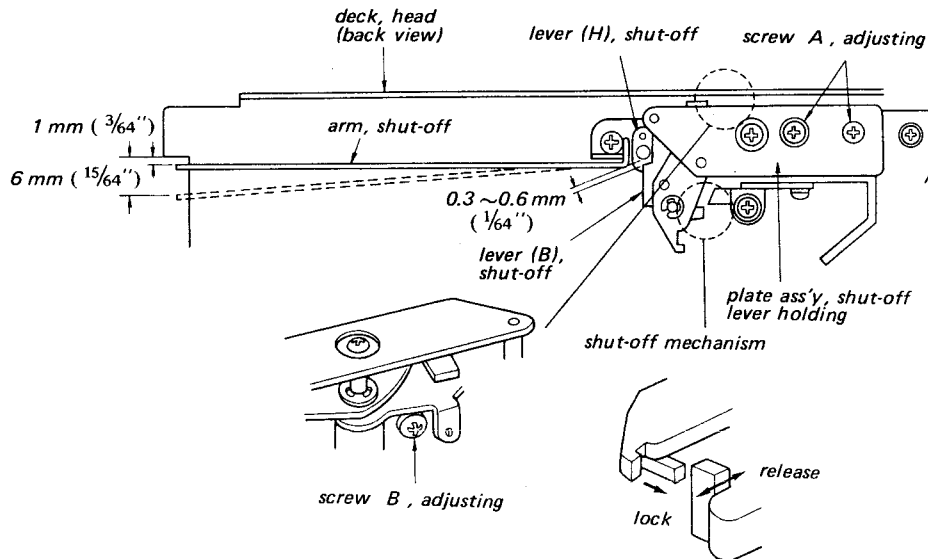

Fig. 11-5 Shut-off mechanism adjustment

**11-3. Tension Regulator Back-tension Adjustment**

In FWD & FF modes

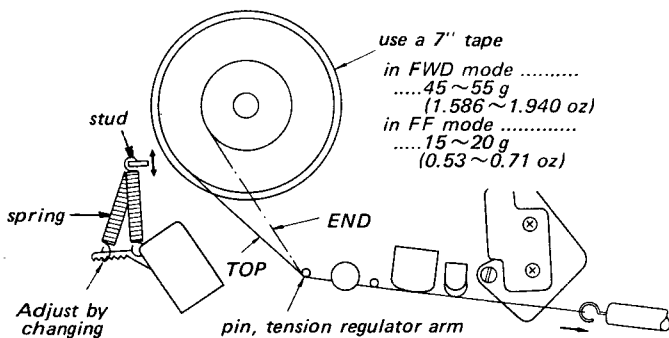

Fig. 11-6 Tension regulator back-tension adjustment

- (1) Make the tension regulator adjustment.
- (2) Adjust by changing the hooking position of the spring to obtain the specified values on the tension gauge at the beginning and the end of the tape as shown in Fig. 11-6.

If it is not obtained the specified values, adjust by bending the stud or perform the tension regulator adjustment.

**11-4. Pinch Roller Stroke & Height Adjustments**

- (1) Remove the head deck (See page 6).
- (2) Adjust the screw ① so that the pinch roller shaft comes in contact with the retractive lever at the position (A) shown in Fig. 11-8, in STOP mode.

- (3) Fix the screw ① while pushing the joint lever in the direction shown with arrow in Fig. 11-7.
- (4) Put the dummy capstan  $\times$  into the capstan bearing and be sure that the pinch roller shaft moves by approx. 3~4 mm ( $1/8 \sim 5/12$  inch) on the surface of the retractive lever when the function selector knob is changed from STOP to FWD.
- (5) Be sure that the washer for the pinch roller shaft does not come in contact with the part indicated with  $\blacktriangle$  on the retractive lever when the function selector knob is changed slowly from FWD to FF.
- (6) After the adjustment, apply lock paint to the screw.

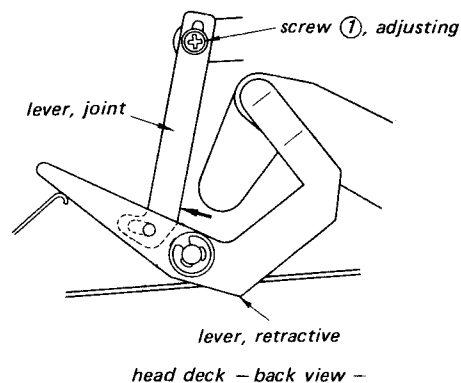

Fig. 11-7 Pinch roller stroke adjustment



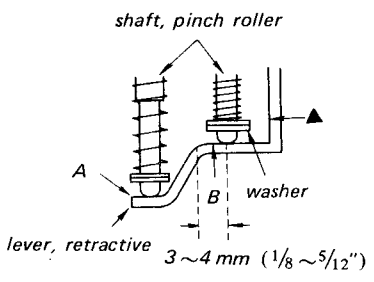

Fig. 11-8 Pinch roller stroke adjustment

(7) Loosen the pinch roller height adjusting screw shown in Fig. 12-1 and adjust by moving the shaft upwards or downwards to obtain the values specified in Fig. 11-9.

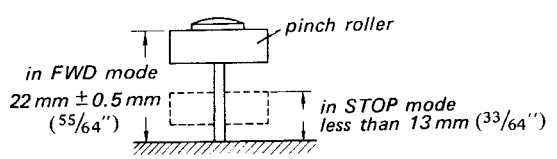

Fig. 11-9 Pinch roller height adjustment

※ Dummy Capstan

As the pinch roller stroke adjustment and the pinch roller pressure check require the dummy capstan, make it as follows;

Prepare a flywheel ass'y (for TC-366) and remove the capstan shaft (dummy capstan) from the flywheel ass'y by patting the head of the capstan shaft with the hammer, taking care not to bend the shaft. Flywheel Ass'y Part No.: X-34720-03

**11-5. Pinch Roller Pressure Check**

— in STOP mode —

(1) Put the dummy capstan ※ into the capstan bearing and be sure that the clearance between the pinch levers (A) and (B) is approx. 0.5mm (1/64").

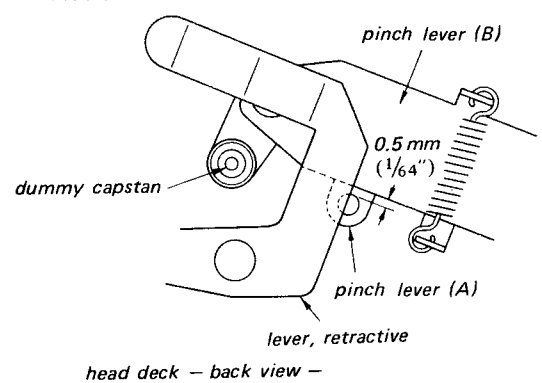

Fig. 11-10 Pinch roller pressure check

Be sure that the tension gauge indicates 800 ~ 1,000 g (1 lb 12 oz ~ 2 lb 3 oz) when the pinch roller is detached from the capstan in FWD mode.

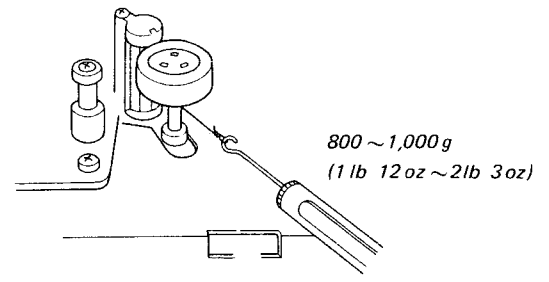
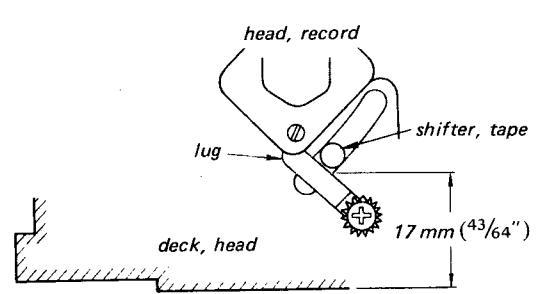

Fig. 11-11 Pinch roller pressure check

**11-6. Tape Shifter Position Adjustment**

— in STOP mode —



Adjust by positioning the lug.

Fig. 11-12 Tape shifter position adjustment

**11-7. Speed Selector Cam Position Adjustment**

— in FWD mode —

Adjust the screw to locate the idler arm (c) pin at the center position between the two stopper slots shown, at 19 cm/s tape speed.

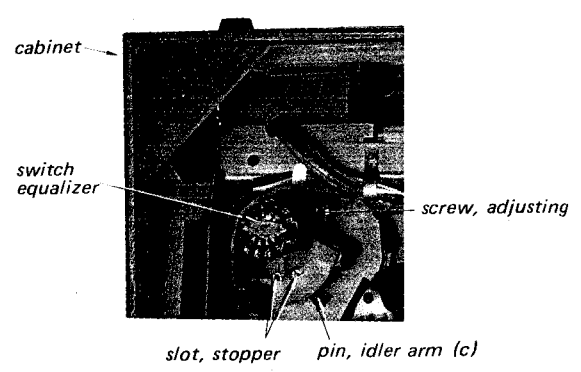
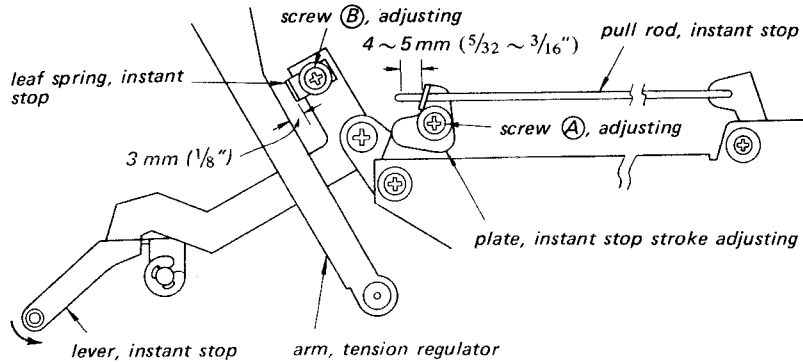

Fig. 11-13 Speed selector cam position adjustment

**11-8. Instant Stop Adjustment**

— in STOP mode —

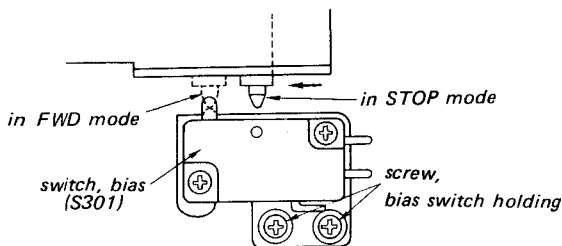

**Fig. 11-14 Instant stop adjustment**

- (1) Be sure that the tension regulator adjustment has been made.
- (2) Adjust the screw (A) so that the distance between the top of the instant stop pull rod and the instant stop stroke adjusting plate is 4 ~ 5 mm ( $\frac{5}{32} \sim \frac{3}{16}$ " ) in STOP mode.
- (3) Be sure that the clearance between the pinch roller and the capstan is more than 1 mm ( $\frac{3}{64}$ " ) when pulling the instant stop lever in FWD mode, and the instant stop knob is not locked when pulling it in STOP mode.
- (4) Adjust the screw (B) so that the clearance between the tension regulator arm and the instant stop leaf spring is 3 mm ( $\frac{1}{8}$ " ) in STOP mode.
- (5) After the adjustment, apply lock paint to the screws.

**11-9. Bias Switch Position Adjustment**

- (1) Loosen the two screws and adjust by positioning the switch.
- (2) Be sure that the switch is in ON position in FWD mode, and when the function selector knob is changed slowly from FWD to STOP, the record knob is released after the switch is in OFF.



**Fig. 11-15 Bias switch position adjustment**

**11-10. Bias Timing Switch Position Adjustment**

— in FWD mode —

Loosen the two screws and adjust by positioning the switch.

*in modes except FWD mode: 0.5 ~ 0.7 mm ( $\frac{1}{64}$ " )  
in FWD mode: To contact sufficiently*

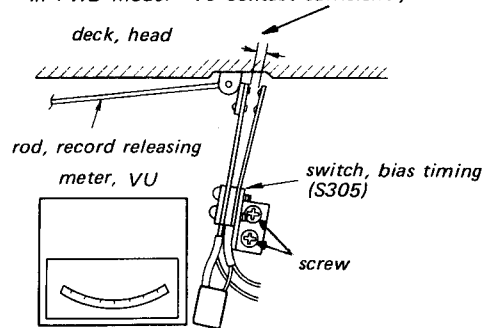
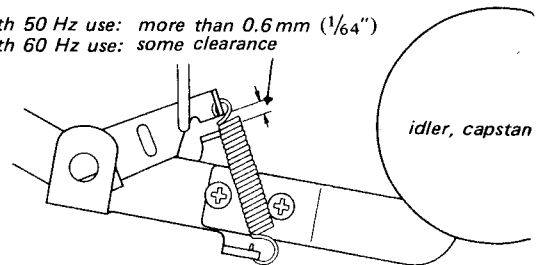

**Fig. 11-16 Bias timing switch position adjustment**

**11-11. Idler Arm (C) Stroke Check**

— in FWD mode at 4.8 cm/s ( $1\frac{7}{8}$  ips) tape speed —

*with 50 Hz use: more than 0.6 mm ( $\frac{1}{64}$ " )  
with 60 Hz use: some clearance*



**Fig. 11-17 Idler arm (C) stroke check**



**11-17. Brake Adjustment**

— in STOP mode —

supply brake torque	direction A	500~750 g·cm (6.96~10.4 oz·inch)
	direction B	1,000~1,800 g·cm (13.9~25 oz·inch)

take-up brake torque	direction C	400~550 g·cm (5.56~7.65 oz·inch)
	direction D	1,600~2,200 g·cm (22.2~30.6 oz·inch)

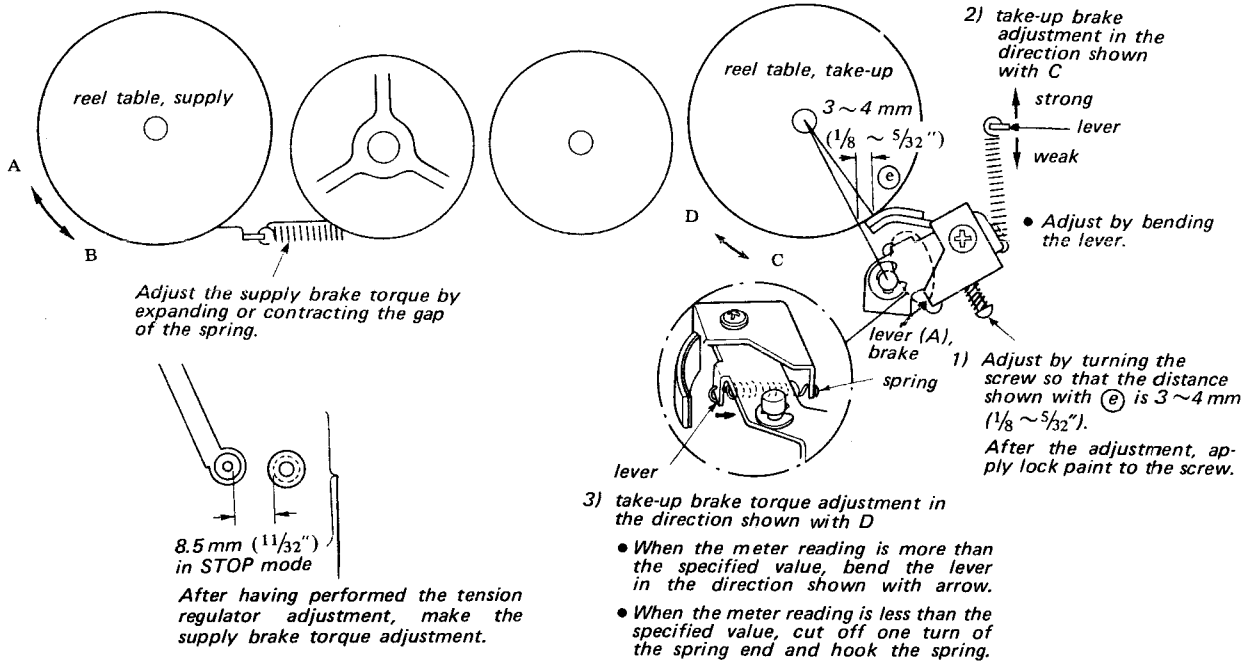

Fig. 11-23 Brake adjustment

**11-18. Tape Slack Check**

Place the machine in vertical position and thread the tape with 7" reel.

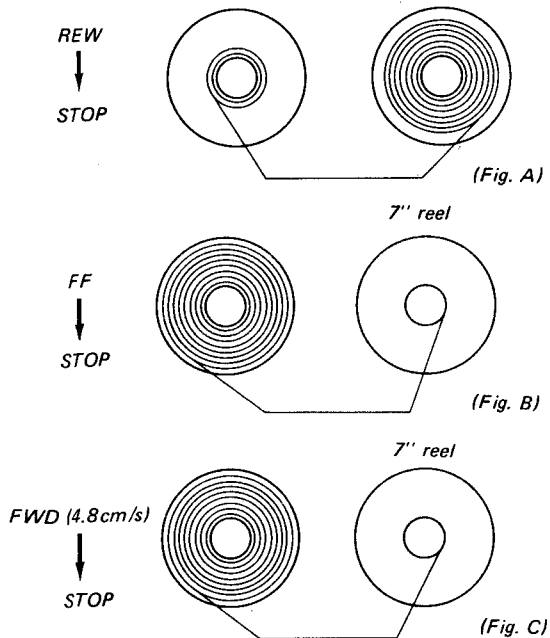

Fig. 11-24 Tape slack check

- (1) When changing the function selector knob slowly from REW to STOP at the end of the tape, be sure not to slack the tape (See Fig. A).
- (2) When changing the function selector knob from FF to STOP at the beginning of the tape, be sure not to slack the tape (See Fig. B).
- (3) When pulling the instant stop knob in FWD mode at the beginning of the tape, be sure not to slack the tape.
- (4) When changing the function selector knob from FWD to STOP at the beginning of the tape at the 4.8cm/s (17/8 ips) tape speed, be sure not to slack the tape (See Fig. C).

**11-19. FF & REW Torque Adjustments**  
 – in FF & REW modes –

Adjust the position of the leaf spring to obtain the specified values on the torque meter.  
 (Read the values when the driving idler is forced to stop the motion.)

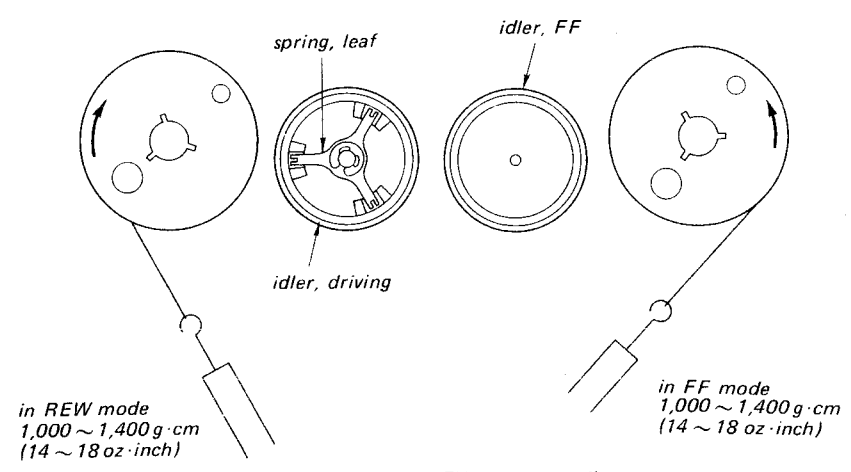
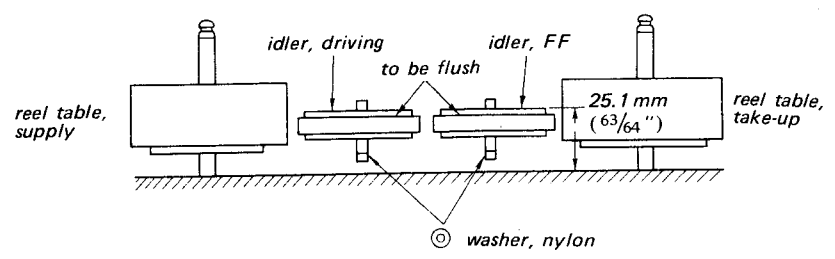

Fig. 11-25 FF & REW torque adjustments

**11-20. FF & Driving Idler Height Adjustments**  
 – in STOP mode –



**nylon washer**

Part No.	thickness
3-425-197-01	0.13 mm
3-425-197-11	0.25 mm
3-425-197-21	0.50 mm

Adjust the height of the idler by adding or removing the nylon washer.

Fig. 11-26 FF & driving idler height adjustments

**11-21. Record Releasing Rod Adjustment**  
 – in STOP mode –

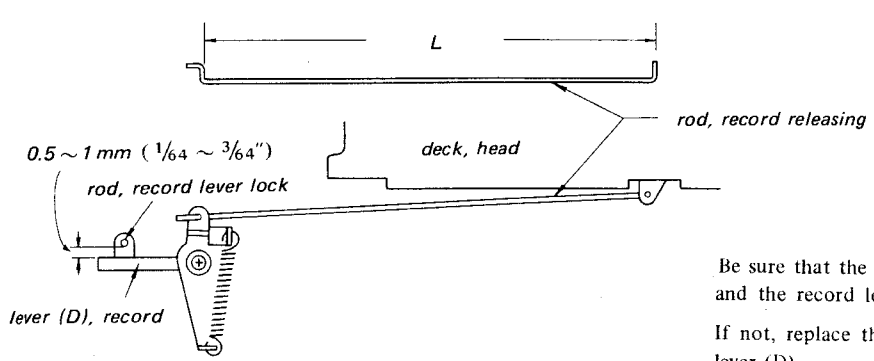

**rod, record releasing**

Part No.	L (length)
3-472-240-02	150 mm
3-472-240-11	150.5 mm
3-472-240-21	151 mm

Be sure that the clearance between the record lever lock rod and the record lever (D) is 0.5 ~ 1 mm (1/64 ~ 3/64").

If not, replace the record releasing rod or bend the record lever (D).

Fig. 11-27 Record releasing rod adjustment

**11-22. Flywheel Brake Check**

— in REW mode —

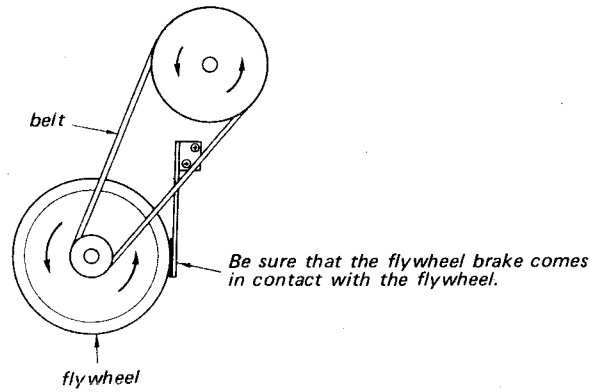

Fig. 11-28 Flywheel brake check

**11-23. Tape Speed Adjustment**

- (1) Playback the SONY speed check tape (SPC-47) at 19 cm/s (7½ ips) tape speed in horizontal position.
- (2) If the counter reading is out of 3,960~4,040 Hz, replace with the motor pulley with identifying mark shown below.  
(As for Part No. of the motor pulley, refer to page 40.)

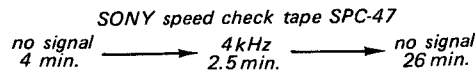
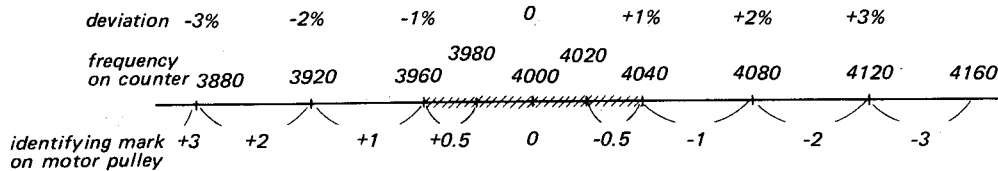

Fig. 11-29 Tape speed adjustment

	Standard		
	19cm/s (7½ ips)	9.5cm/s (3¾ ips)	4.8cm/s (1⅞ ips)
Deviation (%)	±1.5	±1.5	±1.5
Variation Limit (%)	1	1	1



## 12. ELECTRICAL ADJUSTMENT

**Note:**

- (1) Before connecting the measuring equipments to the input or the output jack of the machine, take the impedance-matching correctly as shown below.

Input	Rated Input Level (Input Impedance)	Output	Rated Output Level (Load Impedance)
MIC	-60 dB (600Ω)	LINE OUT	0 dB (100 kΩ)
AUX	-10 dB (10 kΩ)		
REC/PB Connector	-33 dB (80 kΩ)	REC/PB Connector	0 dB (100 kΩ)

**Input Connection**

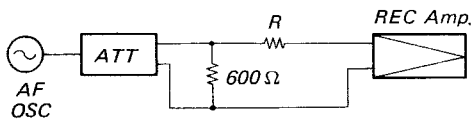

Input	R
AUX	10 kΩ
MIC	0 Ω
REC/PB Connector	80 kΩ

**Output Connection**

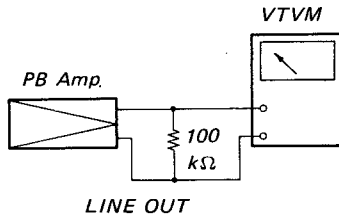

- (2) During the adjustment, the MIC VR and the AUX VR should be set at the position described below, unless otherwise specified.

MIC VR..... Set them to the position where the LINE OUT level is 0 dB (0.775V) when delivering a 1 kHz signal of -60 dB (0.775 mV) into the MIC jack with the AUX VR set to the minimum position and the MONITOR SW set to SOURCE position.

AUX VR..... Set them to the position where the LINE OUT level is 0 dB (0.775V) when delivering a 1 kHz signal of -10 dB (0.24V) into the AUX jack with the MIC VR set to the minimum position and the MONITOR SW set in SOURCE position.

- (3) Before making the head adjustment, demagnetize and clean the RECORD head and the PB head with swab or soft cloth dampened with denatured alcohol.
- (4) The switches should be set in the following positions, unless otherwise specified.

TAPE SELECT SW ..... NORMAL  
NOISE SUPPRESS SW ..... OFF

- (5) A new tape or a sufficiently-demagnetized tape should be used as a blank test tape.
- (6) The adjustment should be made in numerical order.

- (12-1) Power Voltage Adjustment
- (12-2) Tape Pass Adjustment
- (12-3) Tape Curl Adjustment
- (12-4) P.B. Head Azimuth & Angle Adjustments
- (12-5) P.B. Head Phase Check
- (12-6) P.B. Output Level Adj. & Level Meter Calibration
- (12-7) P.B. Equalizer Adjustment
- (12-8) P.B. S/N Ratio Check
- (12-9) Trap Coil Adjustment
- (12-10) Record Head Azimuth and Track Position Adjustments
- (12-11) Record Head Phase Check
- (12-12) Record Bias Adjustment
- (12-13) Record Level Adjustment
- (12-14) Record Equalizer Adjustment
- (12-15) Dummy Coil Adjustment
- (12-16) Erase Ratio Measurement
- (12-17) Overall Frequency Response Measurement
- (12-18) Overall S/N Ratio Measurement
- (12-19) Distortion Measurement
- (12-20) Cross-talk Measurement (between channels)
- (12-21) Cross-talk Measurement (between tracks)

**Notes on replacing the heads:**

**1. Erase Head Removal**

When removing the erase head from the head deck, remove the two screws shown with ▲ in Fig. 12-1. (Do not remove the three screws shown with ※ in Fig. 12-1)

**2. Record or P.B. Head Removal**

When removing the record or the p.b. head, remove the respective angle adjusting screws. (Do not turn the screws except the angle adjusting screws.)

**3. After replacing the heads, be sure the following items.**

*Erase Head*

- (1) The tape touches at the center of erase head cores.
- (2) The tape comes in contact with the scrape flutter filter roller in FWD mode.

- (3) Tape Pass Adjustment (See page 28)
- (4) Record Bias Adjustment (See page 33)
- (5) Record Level Check (See page 34)
- (6) Record Equalizer Adjustment (See page 34)
- (7) Erase Ratio Measurement (See page 35)

*Record Head*

- (1) Tape Pass Adjustment (See page 28)
- (2) Record Bias Adjustment (See page 33)
- (3) Record Head Azimuth Adjustment (See page 32)
- (4) Record Head Phase Check (See page 33)
- (5) Record Level Adjustment (See page 34)
- (6) Record Equalizer Adjustment (See page 34)
- (7) Overall Frequency Response (See page 36)

*P.B. Head*

- (1) Tape Pass Adjustment (See page 28)
- (2) P.B. Head Azimuth and Angle Adjustments (See page 30)
- (3) P.B. Head Phase Check (See page 30)
- (4) P.B. Output Level Adjustment (See page 30)
- (5) P.B. Equalizer Adjustment (See page 31)

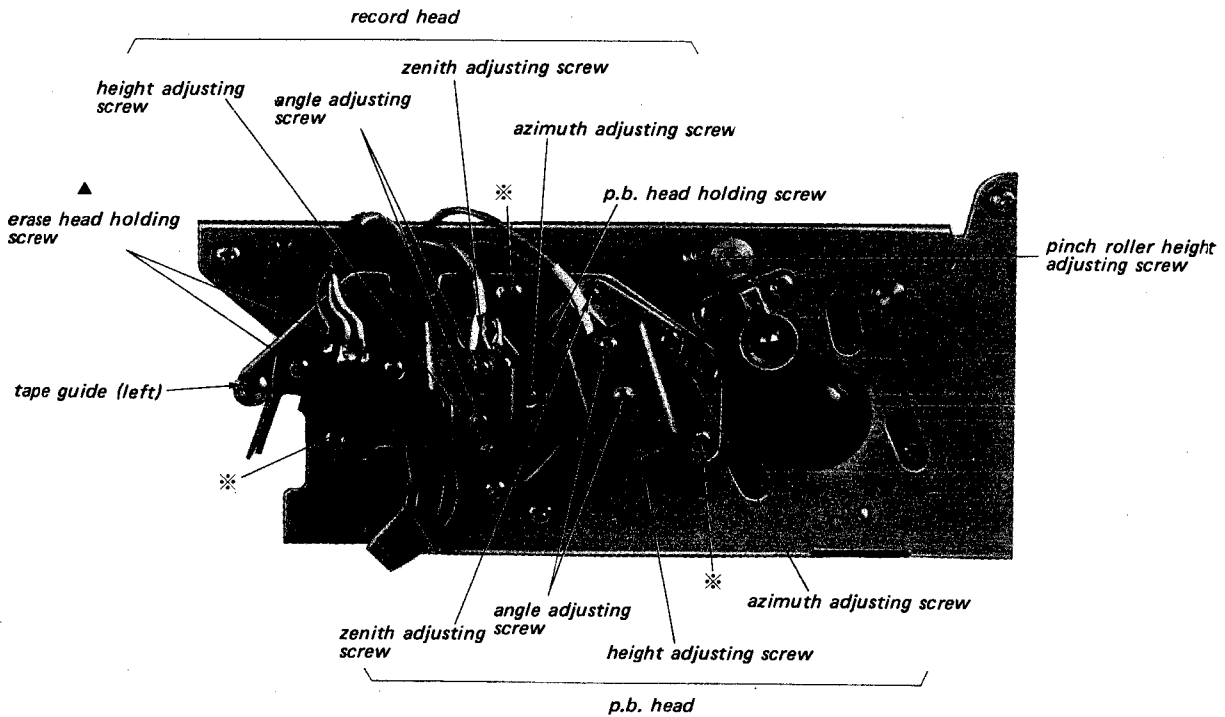

**CAUTION:** Do not remove the three screws marked with \*.

**Fig. 12-1** Adjusting parts location (1)

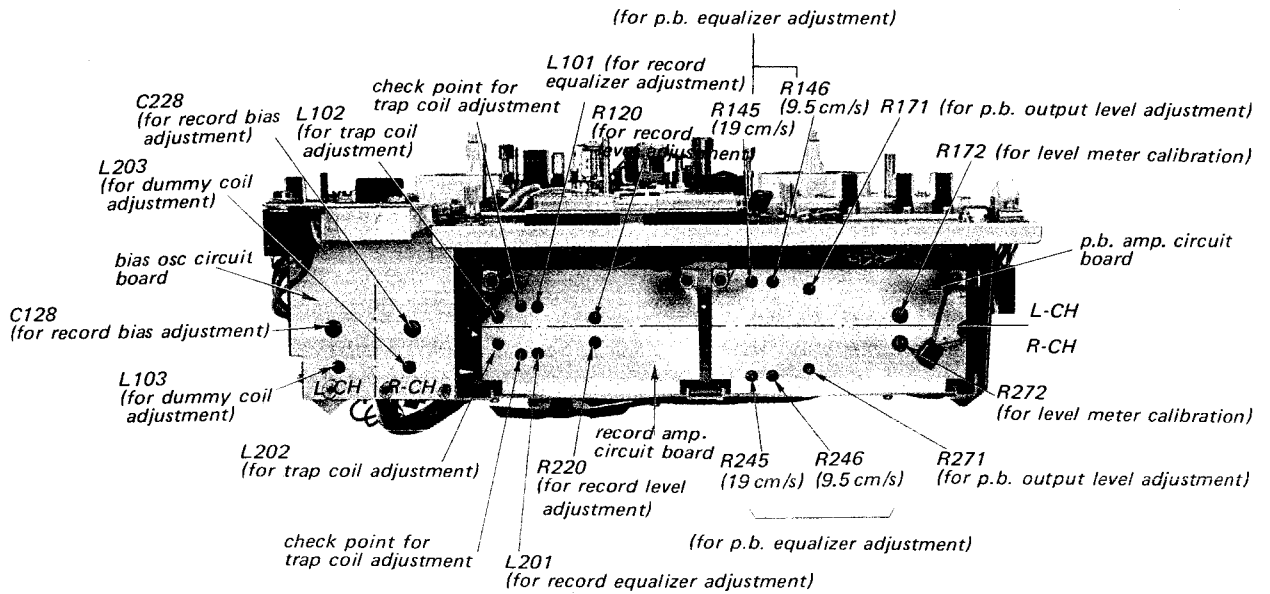

Fig. 12-2 Adjusting parts location (2)

12-1. Power Voltage Adjustment

Connection:

As shown in Fig. 12-3.

Adjusting Parts:

R309 100 kΩ (B) See Fig. 12-4.

Procedures:

- (1) Be sure that the correct power voltage is supplied.
- (2) Place the machine in STOP mode.
- (3) Adjust R309 to obtain 25 ~ 26V on the VTVM.

CAUTION

Be careful not to short-circuit the B<sup>+</sup> circuit to ground, or the transistor Q304 will be broken.

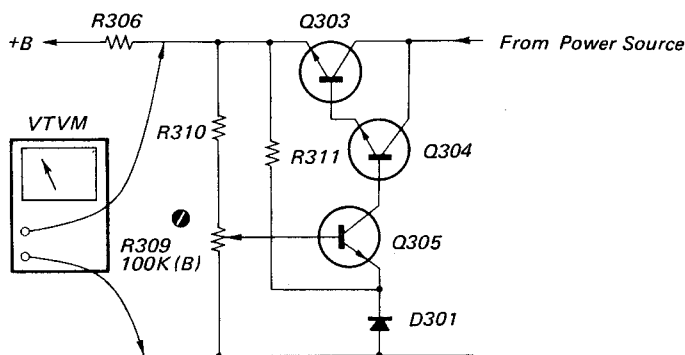

Fig. 12-3 Power voltage adjustment

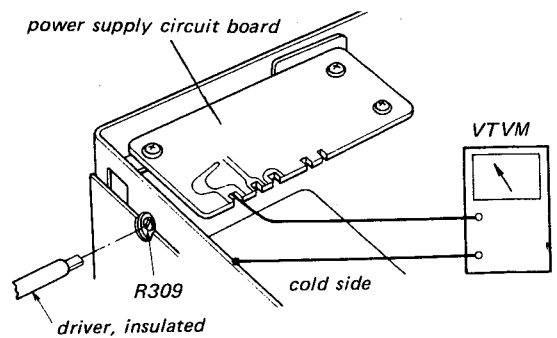

Fig. 12-4 Power voltage adjustment

**12-2. Tape Pass Adjustment**

**(A) Tape Guide (left) Adjustment**

*Adjusting Parts:*

tape guide (left) See Fig. 12-1

- (1) Thread a tape.
- (2) Align the upper edge of the tape just on the upper edge of the erase head core by turning the tape guide located on the left side of the erase head.
- (3) Turn the tape guide located on the left side of the erase head clockwise by approximately 35° from the position obtained in the preceding procedures, so that the upper edge of the tape is approximately 0.05 mm lower than that of the erase head core.

*Procedures:*

- (1) Turn the azimuth adjusting screws and the angle adjusting screws so that the record head and the playback head are positioned nearly as shown in Fig. 12-5.
- (2) Turn the p.b. head height adjusting screw so that the upper edge of the p.b. head is 0.025 mm lower than that of the tape and memorize the angle of turns.
- (3) Turn the p.b. head zenith adjusting screw by the same angle of turns to the same direction of the p.b. head height adjusting screw.

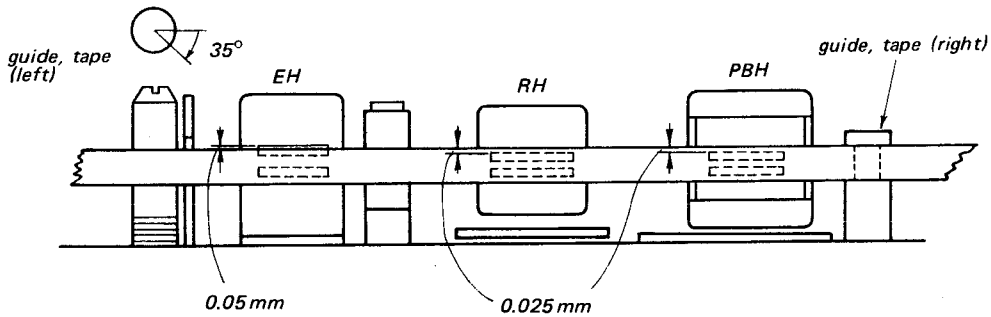

*Fig. 12-5 Tape guide (left) adjustment*

**(B) Tentative Record and P.B. Heads Adjustments**

*Adjusting Parts:* (See Fig. 12-1.)

- P.B. Head
  - ① azimuth adjusting screw
  - ② angle adjusting screws
  - ③ height adjusting screw
  - ④ zenith adjusting screw
- Record Head
  - ① azimuth adjusting screw
  - ② angle adjusting screws
  - ③ height adjusting screw
  - ④ zenith adjusting screw

(The p.b. head and the record head adjustments should be made in numerical order.)

- (4) Turn the record head height adjusting screw so that the upper edge of the record head is 0.025 mm lower than that of the tape and memorize the angle of turns.
- (5) Turn the record head zenith adjusting screw by the same angle of turns to the same direction of the record head height adjusting screw.
- (6) Set the machine at 19 cm/s (7½ ips) tape speed.
- (7) Make the tape loose a little by pushing the tension regulator arm pin in the direction shown with arrow in Fig. 12-6 and then adjust the p.b. head and the record head zenith adjusting screws to obtain the reflection of light as shown in Fig. 12-6.

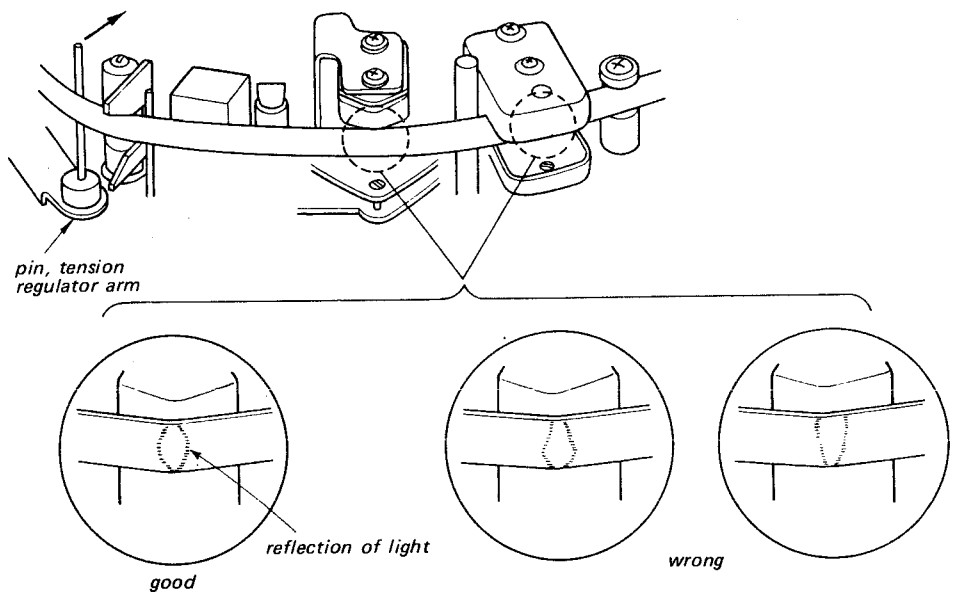

Fig. 12-6 Tentative record and p.b. heads adjustment

12-3. Tape Curl Adjustment

Procedures:

- (1) Set the machine at 4.8 cm/s (17/8 ips) tape speed.
- (2) Be sure that the tape comes in contact with the two tape guides exactly as shown in Fig. 12-7.
  - If the tape is curled at the left tape guide, adjust by bending the tension regulator arm pin with fingers.
  - If the tape is curled at the right tape guide, loosen the two capstan bearing holding screws and adjust by adding or removing the mylar spacer.

**Note:** After adding or removing the mylar spacer, perform the p.b. head zenith adjustment.

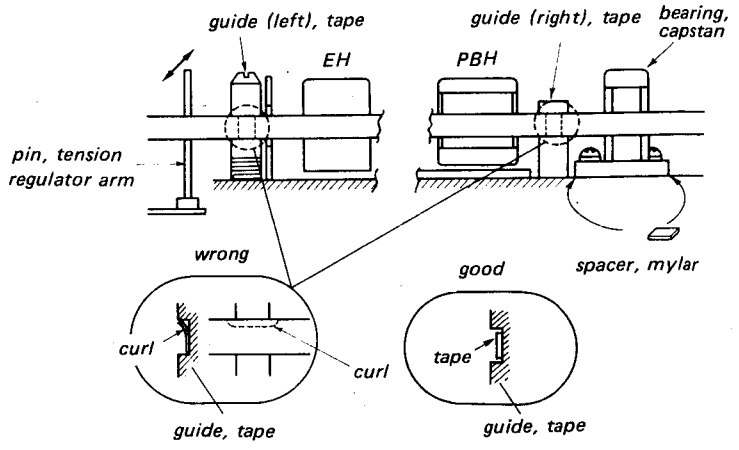

Fig. 12-7 Tape curl adjustment

**12-4. P.B. Head Azimuth and Angle Adjustments**

*Connection:*

As shown in Fig. 12-8.

*Adjusting Parts:*

- p.b. head azimuth adjusting screw (See Fig. 12-1)
- p.b. head angle adjusting screws (See Fig. 12-1)

*Switch Setting:*

- TAPE SPEED switch ..... 19 cm/s (7½ ips)
- MONITOR switch ..... TAPE

*Procedures:*

- (1) Be sure that the p.b. head is secured sufficiently to the head deck with the holding screw shown in Fig. 12-1, and the tape pass adjustment has been made.
- (2) Playback the 1st tone (10kHz) of SONY alignment tape, J-19-F1 or J-19-K1.
- (3) Adjust the p.b. head azimuth adjusting screw with a non-magnetic screw driver to obtain the maximum reading on VTVM in both L-CH and R-CH.
- (4) If the maximum value of R-CH is not the same as that of L-CH, adjust the screw to obtain the mean value of both L-CH and R-CH maximum readings.
- (5) Apply the back-tension by holding lightly the supply reel table, reproducing the alignment tape, and then adjust the angle of the head by loosening the two angle adjusting screws so that the indication on both L-CH and R-CH falls.

**Note:** Unless the p.b. head is installed at correct angle, the indications on the VTVM will go up.

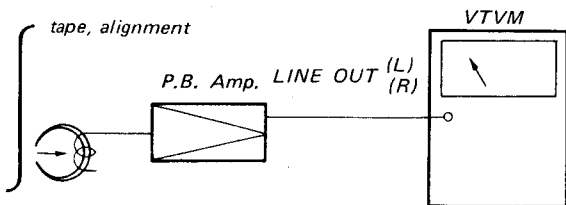

Fig. 12-8 P.B. head azimuth and angle adjustment setup

**12-5. P.B. Head Phase Check**

*Connection:*

As shown in Fig. 12-9.

*Adjusting Parts:*

- p.b. head azimuth adjusting screw (See Fig. 12-1.)

*Switch Setting:*

- MONITOR switch ..... TAPE

*Procedures:*

- (1) Playback the 2nd tone (400Hz) of SONY alignment tape J-19-F1 or J-19-K1.
- (2) Adjust the p.b. head azimuth adjusting screw to obtain the Lissajous figure with no phase difference as shown in Fig. 12-10 on the oscilloscope.
- (3) Playback the 1st tone (10 kHz) of SONY alignment tape J-19-F1, or J-19-K1.
- (4) Adjust the p.b. head azimuth adjusting screw exactly so that the phase difference between L-CH and R-CH is less than 90°.

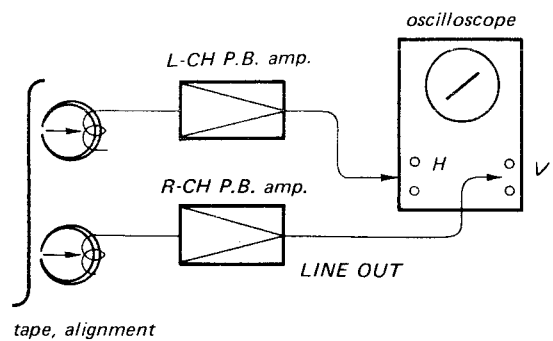

Fig. 12-9 P.B. head azimuth phase check setup

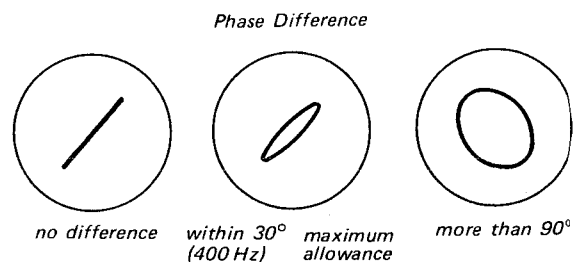

Fig. 12-10 Lissajous figures

**12-6. P.B. Output Level Adjustment and Level Meter Calibration**

*Connection:*

As shown in Fig. 12-11.

*Adjusting Parts:*

- R171 (R271) – P.B. output level adjustment ..... See Fig. 12-2.
- R172 (R272) – Level meter calibration ..... See Fig. 12-2.

*Switch Setting:*

- MONITOR switch ..... TAPE
- TAPE SELECT switch ..... NORMAL
- TAPE SPEED switch ..... 19 cm/s (7½ ips)



**Procedures:**

- (1) Playback the 2nd tone (400 Hz, -0 dB) of SONY alignment tape J-19-F<sub>1</sub> or J-19-K<sub>1</sub>.
- (2) Adjust R171 (R271) to obtain 0 dB (0.775 V) on the VTVM.
- (3) Adjust R172 (R272) so that the pointer of the level meter just stays at the boundary between the red portion and the black portion.
- (4) Change the TAPE SELECT switch to SLH.
- (5) Be sure that the VTVM reading is -2 ~ -3 dB (0.61 ~ 0.55 V).

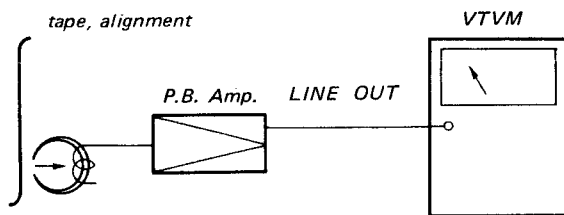

Fig. 12-11 P.B. output level adjustment and level meter calibration setup

**12-7. P.B. Equalizer Adjustment**

**Connection:**

As shown in Fig. 12-12.

**Adjusting Parts:**

- R145 (R245) - 19 cm/s tape speed ..... See Fig. 12-2
- R146 (R246) - 9.5 cm/s tape speed ..... See Fig. 12-2

**Switch Setting:**

- MONITOR switch ..... TAPE
- TAPE SPEED switch ..... 19 cm/s (7½ ips)

**Procedures:**

**CAUTION**

Never fail to make the 19 cm/s equalizer adjustment first.

- A) In using the SONY alignment tape J-19-K<sub>1</sub>
- (1) Playback the 1st tone (10 kHz, -10 dB) of the tape and memorize the reading on the VTVM.
  - (2) Playback the 2nd tone (400 Hz, 0 dB) of the tape and adjust R145 (R245) so that the reading on the VTVM is 10 dB higher than the reading obtained in the preceding procedure (1).

- (3) Change the TAPE SPEED switch from 19 cm/s to 9.5 cm/s (from 7½ ips to 3¾ ips).
  - (4) Playback the 1st tone of the tape and memorize the reading on the VTVM.
  - (5) Playback the 2nd tone of the tape and adjust R146 (R246) so that the reading on the VTVM is 10 dB higher than the reading obtained in the preceding procedure (4).
- B) In using the SONY alignment tape J-19-F<sub>1</sub>
- (1) Playback the 3rd tone (400 Hz, -10 dB) of the tape and memorize the reading on the VTVM.
  - (2) Playback the 4th tone (10 kHz, -10 dB) of the tape and adjust R145 (R245) so that the reading on the VTVM is the same as the reading obtained in the preceding procedure (1).
  - (3) Change the TAPE SPEED switch from 19 cm/s to 9.5 cm/s (from 7½ ips to 3¾ ips).
  - (4) Playback the 3rd tone of the tape and memorize the reading on the VTVM.
  - (5) Playback the 4th tone of the tape and adjust R146 (R246) so that the reading on the VTVM is the same as the reading obtained in preceding procedure (4).

After the adjustment, perform the p.b. output level adjustment and the level meter calibration.

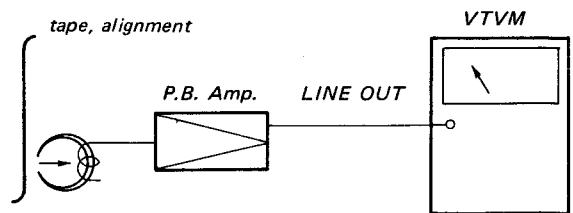

Fig. 12-12 P.B. equalizer adjustment setup

SPEED	4th tone	5th tone	6th tone	7th tone
	10 kHz	7 kHz	80 Hz	40 Hz
19 cm/s (7½ ips)	0 ± 2 dB	0 ± 2 dB	2 ± 2 dB (L-CH)	4 ± 2 dB (L-CH)
			2.5 ± 2 dB (R-CH)	4.5 ± 2 dB (R-CH)

SONY alignment tape "J-19-F<sub>1</sub>"

**12-8. P.B. S/N Ratio Check**

*Connection:*

As shown in Fig. 12-13.

*Switch Setting:*

MONITOR switch ..... TAPE

*Procedures:*

- (1) Playback the 2nd tone (400Hz) of the SONY alignment tape J-19-F<sub>1</sub> or J-19-K<sub>1</sub> and be sure that the VTVM reading is 0 dB (0.775V). If not, make the p.b. output level adjustment again.
- (2) Set the machine in FWD mode with no tape, by pushing the shut-off lever with finger.
- (3) Be sure that the VTVM reading is less than -48 dB (3 mV).
- (4) S/N ratio will change by reversing the sense of motor, so that it is necessary to select the connection of the joint terminals connected to the motor leads to obtain better S/N ratio.

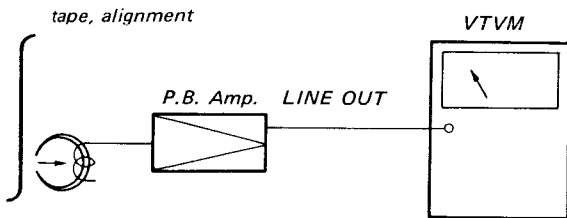

Fig. 12-13 P.B. S/N ratio check setup

**12-9. Trap Coil Adjustment**

*Connection:*

As shown in Fig. 12-14.

*Adjusting Parts:*

L102 (L202) ..... See Fig. 12-2

*Procedures:*

- (1) Set the MIC VOLUME to the minimum position.
- (2) Place the machine in record mode.
- (3) Connect the VTVM to the check point shown in Fig. 12-2.
- (4) Adjust L102 (L202) to obtain the minimum reading on the VTVM.

**Note:** If the VTVM reading is not less than -30 dB (24.5 mV), try to move the positions of MIC jack leads and NOISE SUPPRESS switch leads.

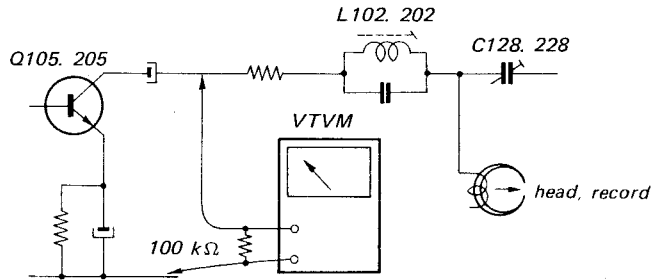

Fig. 12-14 Trap coil adjustment setup

**12-10. Record Head Azimuth and Track Position Adjustments**

*Connection:*

As shown in Fig. 12-15.

*Adjusting Parts:*

Record Head  
 azimuth adjusting screw } ..... See Fig. 12-1  
 height adjusting screw  
 zenith adjusting screw

*Switch Setting:*

MONITOR switch ..... TAPE

*VR Setting:*

AUX VOLUME ..... indicated on page 25

*Procedures:*

- (1) Be sure that the trap coil adjustment has been made.
- (2) Thread a blank tape.
- (3) Deliver a 15 kHz signal of -30 dB (24.5 mV) into the AUX INPUT jack and record the signal on the blank tape.
- (4) Adjust the record head azimuth adjusting screw so that the VTVM reading is the maximum for both L-CH and R-CH. In case the maximum reading of R-CH is not the same as one of L-CH, take the mean value between L-CH and R-CH. (The mean value should not be fallen more than 1 dB from the maximum value.)
- (5) Deliver a 1 kHz signal of -10 dB (0.24V) into the R-CH AUX INPUT jack and record the signal on the blank tape.
- (6) Adjust the height adjusting screw to obtain the maximum reading on the VTVM and memorize the angle of turns of the screw.

- (7) Turn the zenith adjusting screw by the same angle of turns of the height adjusting screw obtained in preceding procedure (6).
- (8) After the adjustment, check the tape pass adjustment again.

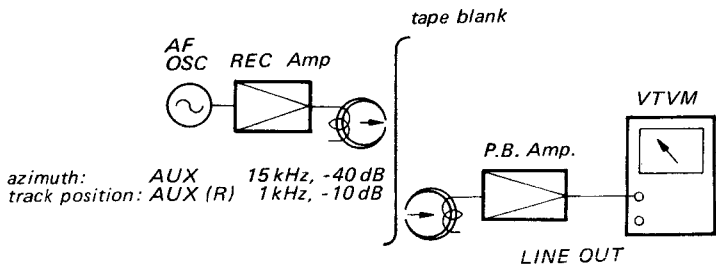

Fig. 12-15 Record head azimuth and track position adjustment setup

**12-11. Record Head Phase Check**

*Connection:*

As shown in Fig. 12-16.

*Switch Setting:*

MONITOR switch ..... TAPE

*VR Setting:*

AUX VOLUME ..... indicated on page 25

*Procedures:*

- (1) Make the p.b. head phase check.
- (2) Thread a blank tape.
- (3) Deliver a 1.5 kHz signal of -10 dB (0.24V) into the AUX INPUT jack and record the signal on the blank tape.
- (4) Be sure to obtain the Lissajous figure as shown in Fig. 12-17.

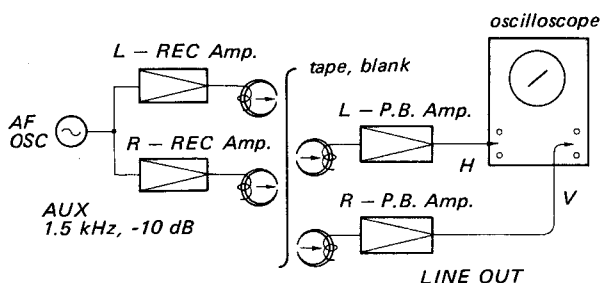

Fig. 12-16 Record head phase check setup

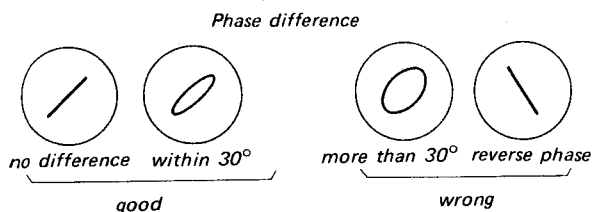

Fig. 12-17 Lissajous figures

**12-12. Record Bias Adjustment**

*Connection:*

As shown in Fig. 12-19.

*Adjusting Parts:*

C128 (C228) ..... See Fig. 12-2

*Switch Setting:*

MONITOR switch ..... TAPE  
 TAPE SPEED switch ..... 19 cm/s (7½ ips)

*VR Setting:*

AUX and MIC VOLUME ..... indicated on page 25

*Procedures:*

- (1) Be sure that the trap coil adjustment has been made.
- (2) Thread a blank tape.
- (3) Deliver a 1 kHz signal of -10 dB (0.245V) into the AUX INPUT jack.
- (4) While recording the signal on the blank tape, turn the trimmer capacitor C128 (C228) clockwise slowly until the VTVM reads the maximum value.
- (5) Continue to turn the trimmer capacitor until the VTVM reads a value 0.5 dB below the maximum reading.
- (6) Disconnect the VTVM and connect it across the record head.
- (7) Be sure that the VTVM reading is approximately 14V.
- (8) Be sure that the VTVM reading decreases by degrees, as the TAPE SPEED switch is changed to 9.5 cm/s and then 4.8 cm/s.
- (9) After the adjustment, apply lock paint to the capacitors.

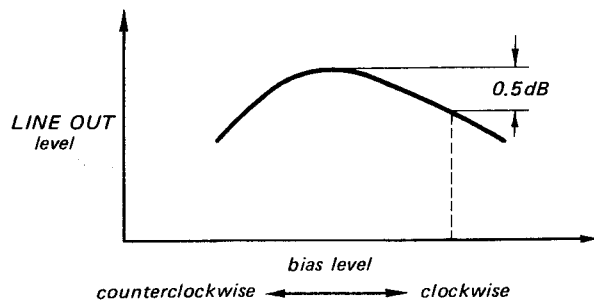

Fig. 12-18 Record bias characteristics

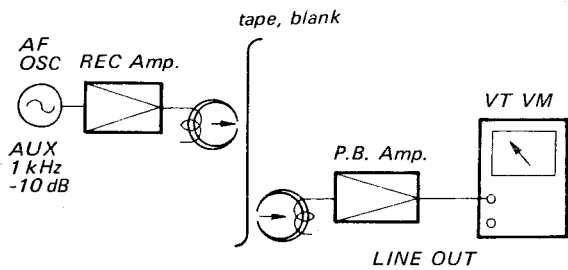

Fig. 12-19 Record bias adjustment setup

**12-13. Record Level Adjustment**

*Connection:*

As shown in Fig. 12-20.

*Adjusting Parts:*

R120 (R220) ..... See Fig. 12-2

*Switch Setting:*

MONITOR switch ..... TAPE  
 TAPE SELECT switch ..... NORMAL  
 NOISE SUPPRESS switch ..... OFF  
 TAPE SPEED switch ..... 19 cm/s (7½ ips)

*VR Setting:*

AUX VOLUME ..... indicated on page 25

*Procedures:*

- (1) Thread a blank tape.
- (2) Deliver a 1 kHz signal of -10 dB (0.24V) into the AUX INput jack and record the signal on the blank tape.
- (3) Adjust R120 (R220) to obtain 0 dB on the VTVM.
- (4) Be sure that the VTVM reading is 0 dB (0.775V) when changing the MONITOR switch to SOURCE and the pointer of the level meter just stays at the boundary between the red portion and the black portion when changing the MONITOR switch to TAPE.
- (5) When changing the TAPE SELECT switch to SLH with the MONITOR switch set in SOURCE, be sure that the reading on the VTVM decreases approximately 1.5 dB.

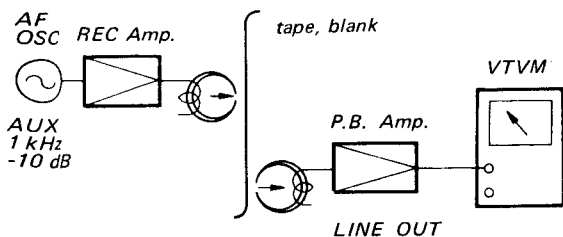

Fig. 12-20 Record level adjustment setup

**12-14. Record Equalizer Adjustment**

*Connection:*

As shown in Fig. 12-21.

*Adjusting Parts:*

L101 (L201) ..... See Fig. 12-2

*Switch Setting:*

MONITOR switch ..... TAPE  
 TAPE SPEED switch ..... 19 cm/s (7½ ips)

*VR Setting:*

AUX VOLUME ..... indicated on page 25

*Procedures:*

- (1) Be sure that the p.b. equalizer adjustment, the trap coil adjustment and the record bias adjustment have been made.
- (2) Thread a blank tape.
- (3) Deliver a 1 kHz signal of -40 dB (7.75 mV) into the AUX INput jack and memorize the reading on the VTVM, while recording the signal on the blank tape.
- (4) Change the signal from 1 kHz to 20 kHz.
- (5) Adjust L101 (L201) to obtain the same reading obtained in preceding procedure (3) on the VTVM.
- (6) When changing the signal continuously from 20 kHz to 10 kHz be sure that the deviation on the VTVM is within ±3 dB. If the deviation is more than ±3 dB in level, make the tape pass and the record head azimuth adjustments.

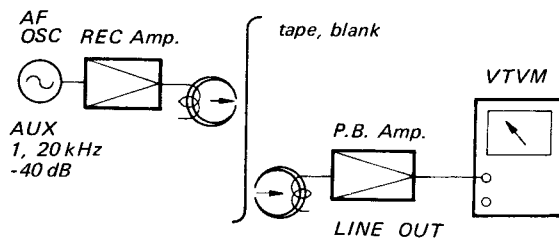

Fig. 12-21 Record equalizer adjustment setup

12-15. Dummy Coil Adjustment

Connection:

As shown in Fig. 12-22.

Adjusting Parts:

L103 (L203) ..... See Fig. 12-2

Switch Settings:

MONITOR switch ..... TAPE  
 TAPE SPEED switch ..... 19 cm/s (7½ ips)

VR Setting:

AUX VOLUME ..... indicated on page 25

Procedures:

- (1) Thread a blank tape.
- (2) Deliver a 20 kHz signal of -30 dB (24.5 mV) into the L-CH (R-CH) AUX INPUT jack and place the machine in stereo-record mode.
- (3) Memorize the VTVM reading.
- (4) Set the L-CH (R-CH) in record mode.
- (5) Adjust L203 (L103) with a non-magnetic screw driver, taking care not to break the core so that the VTVM reading is the same as the reading obtained in preceding procedure (3).

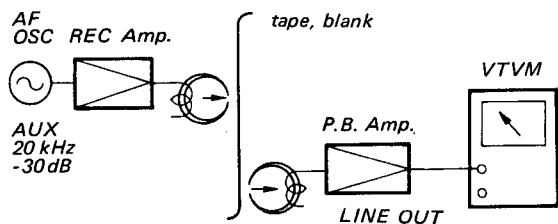

Fig. 12-22 Dummy coil adjustment setup

12-16. Erase Ratio Measurement

Connection:

As shown in Fig. 12-23.

Switch Setting:

MONITOR switch ..... TAPE

VR Setting:

AUX VOLUME ..... indicated on page 25

Procedures:

- (1) Thread a blank tape.
- (2) Deliver a 1 kHz signal of +10 dB (2.5V) into the AUX INPUT jack and record the signal on the blank tape.
- (3) Rewind the tape and erase a part of the recorded tape (record mode with no signal input).
- (4) Memorize the VTVM reading on the recorded part and the erased part of the tape.
- (5) Be sure that the ratio of the recorded part to the erased part in level is more than 65 dB.

If not, check the tape pass adjustment and that the erasing current is 80~120 mA. To measure the erasing current, connect the two 1Ω resistors in series to the erase head as shown in Fig. 12-24 and the VTVM across the 1Ω resistor.

Be sure that the VTVM reading is 80~120 mV.

**Note:** Take impedance-matching correctly for the band-pass filter.

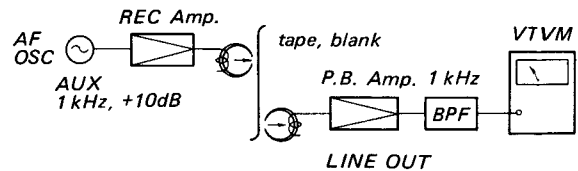

Fig. 12-23 Erase ratio measurement setup

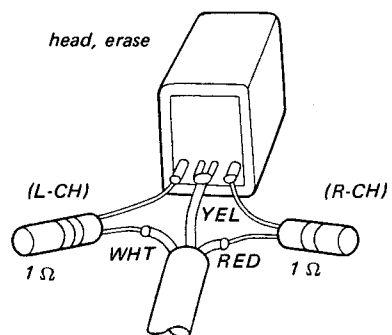

Fig. 12-24 Erasing current check setup

**12-17. Overall Frequency Response Measurement**

*Connection:*

As shown in Fig. 12-25.

*Switch Setting:*

MONITOR switch ..... TAPE

*VR Setting:*

AUX VOLUME ..... indicated on page 25

*Procedures:*

- (1) Be sure that the trap coil adjustment has been made.
- (2) Thread a blank tape.
- (3) Deliver a 1 kHz signal of -40 dB (7.75 mV) into the AUX INPUT jack and record the signal on the blank tape and memorize the VTVM reading.
- (4) Deliver 50 Hz, 100 Hz, 5 kHz, 7 kHz, 12.5 kHz and 18 kHz signals in turn and record them on the blank tape and memorize the VTVM readings respectively.
- (5) Be sure that each deviation in level against 1 kHz signal is within the values shown in the table below.  
If not, perform the record equalizer and the record bias adjustments.

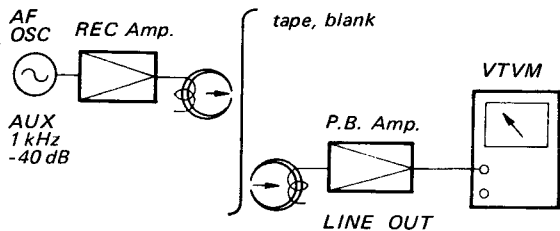

Fig. 12-25 Overall frequency response measurement setup

Deviation against the 1 kHz signal

frequency	50 Hz	100 Hz	5 kHz	7 kHz	12.5 kHz	18 kHz
tape speed						
19 cm/s (7½ ips)	± 3 dB	± 3 dB	± 3 dB	± 3 dB	± 3 dB	+3 -6 dB
9.5 cm/s (3¾ ips)	+ 3 dB -10 dB	± 3 dB	± 3 dB	± 3 dB	+ 3 dB -12 dB	
4.8 cm/s (1⅞ ips)	+ 3 dB -10 dB	± 3 dB	+ 3 dB -7 dB			

**12-18. Overall S/N Ratio Measurement**

*Connection:*

As shown in Fig. 12-26.

*Switch Setting:*

MONITOR switch ..... TAPE

*VR Setting:*

AUX VOLUME ..... indicated on page 25

*Procedures:*

- (1) Thread a blank tape.
- (2) Deliver a 1 kHz signal of -10 dB (0.24 V) into the AUX INPUT jack and record the signal on the blank tape.
- (3) Remove the input connection of the audio generator and terminate the MIC and the AUX INPUT jacks with the dummy resistors (MIC-600Ω, AUX-10 kΩ).
- (4) Rewind the recorded tape and erase a part of the recorded tape (record mode with no signal input).
- (5) Be sure that the ratio of the recorded part of the tape to the erased part on the VTVM is more than 45 dB.

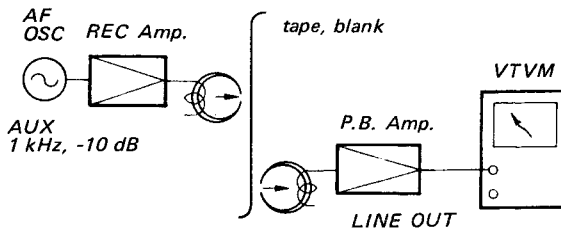

Fig. 12-26 Overall S/N ratio measurement setup

**12-19. Distortion Measurement**

*Connection:*

As shown in Fig. 12-27.

*Switch Setting:*

MONITOR switch ..... TAPE

*VR Setting:*

AUX VOLUME ..... indicated on page 25

*Procedures:*

- (1) Before measuring the distortion, be sure that the trap coil adjustment has been made.



- (2) Thread a blank tape.
- (3) Deliver a 1 kHz signal of -10 dB (0.24V) into the AUX INPUT jack and record the signal on the blank tape.
- (4) Be sure that the reading on the distortion meter is less than 1.5%.

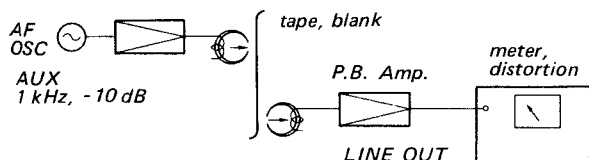

Fig. 12-27 Distortion measurement setup

**12-20. Cross-talk Measurement (between channels)**

*Connection:*

As shown in Fig. 12-28.

*Switch Setting:*

MONITOR switch ..... TAPE

*VR Setting:*

AUX VOLUME ..... indicated on page 25

*Procedures:*

- (1) Thread a blank tape.
- (2) Place the machine in stereo-record mode.
- (3) Deliver a 1 kHz signal of +10 dB (2.5V) into the L-CH AUX INPUT jack.
- (4) Be sure that the ratio of the L-CH LINE OUTPUT to the R-CH LINE OUTPUT on the VTVM is more than 45 dB.

**Note:** Take impedance-matching correctly for the band-pass filter.

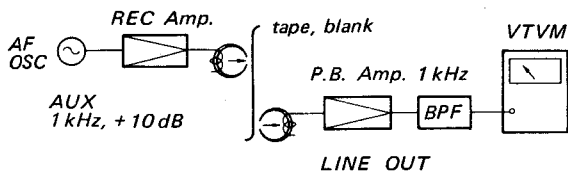

Fig. 12-28 Cross-talk measurement setup (between channels)

**12-21. Cross-talk Measurement (between tracks)**

*Connection:*

As shown in Fig. 12-29.

*Switch Setting:*

MONITOR switch ..... TAPE

*VR Setting:*

AUX VOLUME ..... indicated on page 25

*Procedures:*

- (1) Thread a blank tape.
- (2) Place the machine in stereo-record mode.
- (3) Deliver a 1 kHz signal of +10 dB (2.5V) into the L-CH & R-CH AUX INPUT jacks and record the signal on the blank tape.
- (4) Playback the tape and memorize the L-CH or R-CH VTVM reading, and then take up the tape.
- (5) Turn the recorded tape upside down and put it on the supply reel table.
- (6) Playback the recorded portion of the tape and memorize the L-CH or the R-CH VTVM reading.
- (7) Be sure that the ratio of the VTVM reading obtained in procedure (4) to the VTVM reading obtained in procedure (6) is more than 65 dB.

**Note:** Take impedance-matching correctly for the band-pass filter.

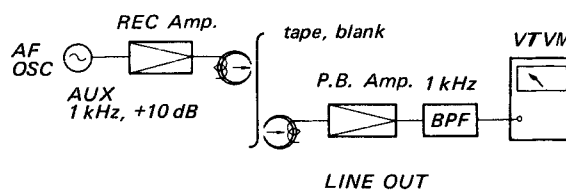

Fig. 12-29 Cross-talk measurement setup (between tracks)

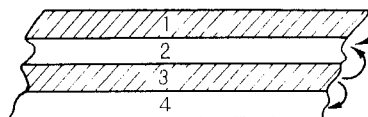

Fig. 12-30 Recorded tape

**12-22. Noise Suppress Check**

*Connection:*

As shown in Fig. 12-31.

*Switch Setting:*

MONITOR switch .....SOURCE  
 NOISE SUPPRESS switch .....OFF

*Procedures:*

- (1) Deliver a 9 kHz signal of -10 dB (0.24V) and adjust the AUX VOLUME to obtain 0 dB (0.775V) on the VTVM.
- (2) Be sure that the VTVM reading is -5.5~ -1.5 dB (0.41~0.65V) when the NOISE SUPPRESS switch is changed to ON.

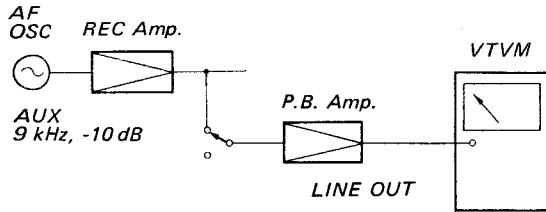

Fig. 12-31 Noise suppress check setup

**12-23. Interference Check between MIC & AUX VOLUMES**

*Connection:*

As shown in Fig. 12-32.

*Switch Setting:*

MONITOR switch .....SOURCE

*Procedures:*

**A) Interference with MIC VOLUME when using AUX Input jack**

- (1) Set the AUX VOLUME to the position indicated on page 25.
- (2) Deliver a 1 kHz signal of -10 dB (0.24 V) into the AUX INPUT jack.
- (3) Be sure that the level variation is within 1 dB on the VTVM when the MIC VOLUME is changed from the minimum to the maximum position.

**B) Interference with AUX VOLUME when using MIC jack**

- (1) Set the MIC VOLUME to the position indicated on page 25.
- (2) Deliver a 1 kHz signal of -60 dB (0.775 mV) into the MIC jack.

- (3) Be sure that the level variation is within 2dB on the VTVM when the AUX VOLUME is changed from minimum to maximum position.

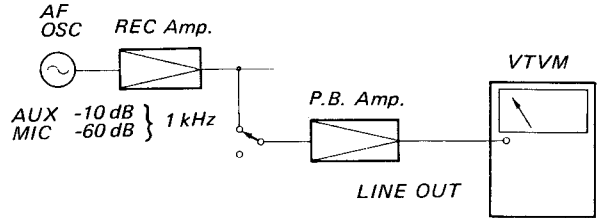

Fig. 12-32 Interference check setup between MIC & AUX VOLUMES

**12-24. Minimum Input Level Check**

*Connection:*

As shown in Fig. 12-33.

*Switch Setting:*

MONITOR switch .....SOURCE

*Procedures:*

**A) Level Check of MIC jack**

- (1) Set the AUX VOLUME to minimum and the MIC VOLUME to maximum position.
- (2) Deliver a 1 kHz signal into the MIC jack and adjust the level of the audio oscillator to obtain 0 dB (0.775V) on the VTVM.
- (3) Be sure that the signal level on the audio oscillator is less than -72 dB (0.2 mV).

**B) Level Check of AUX INPUT jack**

- (1) Set the MIC VOLUME to minimum and the AUX VOLUME to maximum position.
- (2) Deliver a 1 kHz signal into the AUX INPUT jack and adjust the level of the audio oscillator to obtain 0 dB (0.775V) on the VTVM.
- (3) Be sure that the signal level on the audio oscillator is less than -22 dB (61.5 mV).

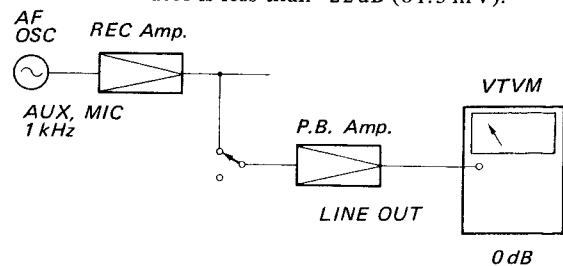

Fig. 12-33 Minimum input level check setup

**12-25. Input & Output Level Checks of REC/P.B. Connector**

*Connection:*

As shown in Fig. 12-34.

*Switch Setting:*

MONITOR switch ..... TAPE

*VR Setting:*

MIC VOLUME ..... indicated on page 25

*Procedures:*

- (1) Deliver a 1 kHz signal of -33 dB (17.5 mV) to terminal No. ① (L-CH) or ④ (R-CH) of the rec./p.b. connector shown in Fig. 12-35.

- (2) Place the machine in record mode.
- (3) Be sure that the reading on the VTVM connected to the terminal No. ③ (L-CH) or ⑤ (R-CH) of the rec./p.b. connector is -5 ~ -1 dB (0.44 ~ 0.7 V).
- (4) Set the MIC VOLUME to the maximum position and adjust the signal level of the audio oscillator to obtain 0 dB (0.775V) on the VTVM and be sure that the signal level on the audio oscillator is less than -40 dB (7.7 mV).

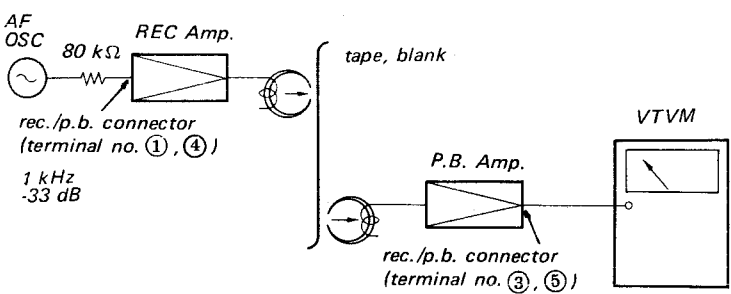

Fig. 12-34 Input & output checks setup of REC/P.B. connector

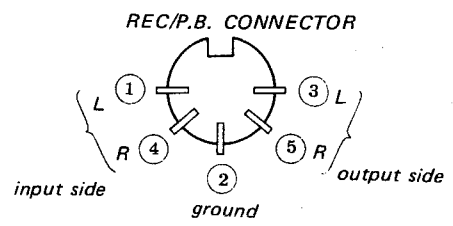

Fig. 12-35 REC/P.B. connector (back view)

**13. CONVERSION TO DIFFERENT POWER LINE FREQUENCY**

If the deck is to be operated on a line frequency different from the frequency for which the deck is adjusted, it may be easily converted. (Remove the reel panel for access.)

**FIRST:** Using a screw-driver, turn the line frequency switch (S305) to the correct position for the power to be used (50 or 60 Hz). See Fig. 13-1.

**SECOND:** Replace the motor pulley as follows:

1. Remove the Instant Stop adjusting plate and withdraw the Instant Stop pull rod.

2. Remove the two screws which hold the motor pulley and take the pulley off of its shaft.
3. Replace the motor pulley with the correct diameter pulley for the line frequency to be used. ALWAYS replace the pulley with the same marking (i.e., "+3") as the one you removed. (This identifying marking indicates a fine speed tolerance diameter.)
4. Adjust by positioning the instant stop adjusting plate so that the distance between the top of the pull rod and the instant stop adjusting plate is 4 ~ 5 mm ( $\frac{5}{32}$  ~  $\frac{13}{64}$ " ) in STOP mode as shown in Fig. 13-2.

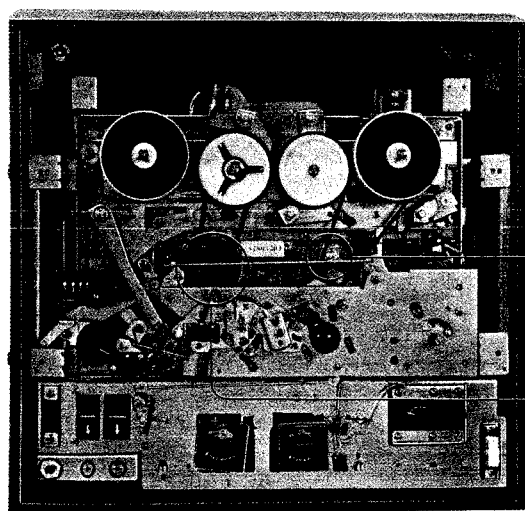

switch, frequency change (S305)  
50 ↔ 60  
pulley motor

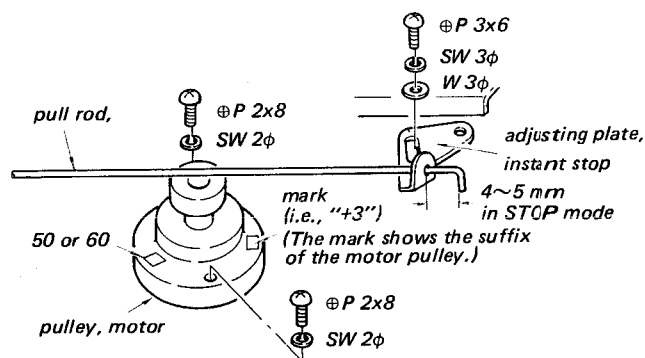

Fig. 13-2

Fig. 13-1

Motor Pulley Part No.			
for 50 Hz		for 60 Hz	
Mark on Motor Pulley	Part No.	Mark on Motor Pulley	Part No.
+3	3-472-184-61	+3	3-472-185-61
+2	3-472-184-51	+2	3-472-185-51
+1	3-472-184-41	+1	3-472-185-41
+0.5	3-472-184-71	+0.5	3-472-185-71
0	3-472-184-01	0	3-472-185-01
-0.5	3-472-184-81	-0.5	3-472-185-81
-1	3-472-184-11	-1	3-472-185-11
-2	3-472-184-21	-2	3-472-185-21
-3	3-472-184-31	-3	3-472-185-31

## 14. ELECTRICAL PARTS LIST

Symbol	Part No.	Description	Symbol	Part No.	Description
<b>MOUNTED CIRCUIT BOARDS</b>					
	X-34724-21-1	Bias Oscillator	C111, 211	1-121-398-	10 $\mu$ F 25V, electrolytic
	X-34724-22-1	Record Amp.	C112, 212	1-121-391-	1 $\mu$ F 50V, "
	X-34724-23-1	Power Supply	C113, 213	1-121-401-	33 $\mu$ F 6.3V, "
	X-34724-24-1	Playback Amp.	C114, 214	1-105-678-12	0.027 $\mu$ F 50V, mylar
			C115, 215	1-105-681-12	0.047 $\mu$ F 50V, "
<b>SEMICONDUCTORS</b>					
Q101, 201	1-801-007-	Transistor 2SC871	C116, 216	1-105-681-12	0.047 $\mu$ F 50V, "
Q102, 202	1-801-007-	" 2SC871	C117, 217	1-105-685-12	0.1 $\mu$ F 50V, "
Q103, 203	1-801-007-	" 2SC871	C118, 218	1-105-685-12	0.1 $\mu$ F 50V, "
Q104, 204	1-801-004-	" 2SC870	C119, 219	1-127-020-	0.22 $\mu$ F 10V, alox
Q105, 205	1-801-004-	" 2SC870	C120, 220	1-121-406-	47 $\mu$ F 3.15V, electrolytic
Q106, 206	1-801-007-	" 2SC871	C121, 221	1-107-125-	56 pF 50V, silvered mica
Q107, 207	1-801-007-	" 2SC871	C122, 222	1-121-394-	4.7 $\mu$ F 16V, electrolytic
Q108, 208	1-801-004-	" 2SC870	C123, 223	1-105-670-12	0.0056 $\mu$ F 50V, mylar
Q109, 209	1-801-004-	" 2SC870	C124, 224	1-105-670-12	0.0056 $\mu$ F 50V, "
Q110, 210	1-801-004-	" 2SC870	C125, 225	1-105-661-12	0.001 $\mu$ F 50V, "
Q111, 211	1-801-004-	" 2SC870	C126, 226	1-105-669-12	0.0047 $\mu$ F 50V, "
Q301		" 2SC634A	C127, 227	1-107-035-11	560 pF 500V, silvered mica
Q302		" 2SC634A	C128, 228	1-141-010-	30 ~ 200 pF, trimmer
Q303		" 2SD28	C129, 229	1-121-748-	10 $\mu$ F 16V, electrolytic
Q304	1-801-004-	" 2SC870	C130, 230		- discarded -
Q305	1-801-004-	" 2SC870	C131, 231	1-121-401-	33 $\mu$ F 6.3V, electrolytic
D101, 201		Diode 1T22	C132, 232	1-107-107-	10 pF 50V, silvered mica
D301		" 1T243M	C133, 233	1-121-403-	33 $\mu$ F 16V, electrolytic
D302		" CD-2	C134, 234	1-105-679-12	0.033 $\mu$ F 50V, mylar
			C135, 235	1-105-667-12	0.0033 $\mu$ F 50V, "
<b>COILS &amp; TRANSFORMERS</b>					
L101, 201	1-231-069-	Coil, equalizer, 1.8/1.45 mH	C136, 236	1-121-398-	10 $\mu$ F 25V, electrolytic
L102, 202	1-409-141-	Coil, trap, 1.8 mH	C137, 237	1-121-416-	100 $\mu$ F 25V, "
L103, 203	1-407-284-	Coil, dummy, 1 mH	C138, 238	1-121-391-	1 $\mu$ F 50V, "
L301	1-407-198-	Micro Inductor, 2.2 mH	C139, 239	1-105-661-12	0.001 $\mu$ F 50V, mylar
L302	1-407-198-	" , 2.2 mH	C140, 240	1-105-667-12	0.0033 $\mu$ F 50V, "
T101, 201	1-427-217-	Transformer, output	C141, 241	1-107-141-	270 pF 50V, silvered mica
T301	1-441-607-	" , power	C142, 242	1-105-661-12	0.001 $\mu$ F 50V, mylar
T302	1-433-140-	" , bias oscillator	C143, 243	1-121-406-	47 $\mu$ F 3.15V, electrolytic
			C144, 244	1-121-406-	47 $\mu$ F 3.15V, "
			C145, 245	1-121-394-	4.7 $\mu$ F 16V, "
<b>CAPACITORS</b>					
C101, 201	1-107-131-	100 pF 50V, silvered mica	C146, 246	1-121-391-	1 $\mu$ F 50V, "
C102, 202	1-121-748-	10 $\mu$ F 16V, electrolytic	C147, 247	1-121-398-	10 $\mu$ F 25V, "
C103, 203	1-121-398-	10 $\mu$ F 25V, "	C148, 248	1-121-391-	1 $\mu$ F 50V, "
C104, 204	1-105-821-12	0.001 $\mu$ F 50V, mylar	C149, 249	1-105-661-12	0.001 $\mu$ F 50V, mylar
C105, 205	1-105-821-12	0.001 $\mu$ F 50V, "	C150, 250	1-105-513-12	0.01 $\mu$ F 50V, "
C106, 206	1-121-413-	100 $\mu$ F 6.3V, electrolytic	C151, 251	1-105-661-12	0.001 $\mu$ F 50V, "
C107, 207	1-121-409-	47 $\mu$ F 16V, "	C152, 252	1-105-665-12	0.0022 $\mu$ F 50V, "
C108, 208	1-121-398-	10 $\mu$ F 25V, "	C301	1-103-675-	1000 pF 50V, polystyrol
C109, 209	1-121-416-	100 $\mu$ F 25V, "	C302	1-107-242-	390 pF 500V, silvered mica
C110, 210	1-121-391-	1 $\mu$ F 50V, "	C303	1-107-221-	560 pF 1500V, "
			C304		- discarded -

Symbol	Part No.	Description
C 305	1-121-396-	4.7 $\mu$ F 50V, electrolytic
C 306	1-105-845-12	0.1 $\mu$ F 50V, mylar
C 307	1-105-759-12	0.033 $\mu$ F 50V, "
C 308	1-107-131-	100 pF 50V, silvered mica
C 309	1-121-388-	1000 $\mu$ F 35V, electrolytic
C 310	1-121-738-	10 $\mu$ F 50V, "
C 311	1-121-388-	1000 $\mu$ F 35V, "
C 312	1-117-036-	1.5 $\mu$ F + 0.5 $\mu$ F 250V, MP
C 313	1-105-845-12	0.1 $\mu$ F 50V, mylar
C 314	1-107-131-	100pF 50V, silvered mica

**RESISTORS**

R 101, 201	1-244-685-	3.3 k $\Omega$ 1/4W, carbon
R 102, 202	1-244-691-	5.6 k $\Omega$ " , "
R 103, 203	1-242-673-	1 k $\Omega$ " , "
R 104, 204	1-242-699-	12 k $\Omega$ " , "
R 105, 205	1-242-715-	56 k $\Omega$ " , "
R 106, 206	1-242-713-	47 k $\Omega$ " , "
R 107, 207	1-242-687-	3.9 k $\Omega$ " , "
R 108, 208	1-242-717-	68 k $\Omega$ " , "
R 109, 209	1-242-651-	120 $\Omega$ " , "
R 110, 210	1-242-717-	68 k $\Omega$ " , "
R 111, 211	1-242-716-	62 k $\Omega$ " , "
R 112, 212	1-242-689-	4.7 k $\Omega$ " , "
R 113, 213	1-242-665-	470 $\Omega$ " , "
R 114, 214	1-242-715-	56 k $\Omega$ " , "
R 115, 215	1-242-725-	150 k $\Omega$ " , "
R 116, 216	1-242-725-	150 k $\Omega$ " , "
R 117, 217	1-242-741-	680 k $\Omega$ " , "
R 118, 218	1-242-741-	680 k $\Omega$ " , "
R 119, 219	1-242-701-	15 k $\Omega$ " , "
R 120, 220	1-221-978-	4.7 k $\Omega$ (B) semi-fixed
R 121, 221	1-242-659-	270 $\Omega$ 1/4W, carbon
R 122, 222	1-242-712-	43 k $\Omega$ " , "
R 123, 223	1-242-737-	470 k $\Omega$ " , "
R 124, 224	1-242-685-	3.3 k $\Omega$ " , "
R 125, 225	1-242-717-	68 k $\Omega$ " , "
R 126, 226	1-242-665-	470 $\Omega$ " , "
R 127, 227	1-242-639-	39 $\Omega$ " , "
R 128, 228	1-242-713-	47 k $\Omega$ " , "
R 129, 229	1-242-643-	56 $\Omega$ " , "
R 130, 230	1-242-691-	5.6 k $\Omega$ " , "
R 131, 231	1-242-669-	680 $\Omega$ " , "
R 132, 232	1-242-681-	2.2 k $\Omega$ " , "
R 133, 233	1-242-689-	4.7 k $\Omega$ " , "
R 134, 234	1-242-689-	4.7 k $\Omega$ " , "

Symbol	Part No.	Description
R 135, 235	1-242-709-	33 k $\Omega$ 1/4W, carbon
R 136, 236	1-242-673-	1 k $\Omega$ " , "
R 137, 237		- discarded -
R 138, 238	1-242-715-	56 k $\Omega$ 1/4W, carbon
R 139, 239	1-242-743-	820 k $\Omega$ " , "
R 140, 240	1-242-649-	100 $\Omega$ " , "
R 141, 241	1-242-697-	10 k $\Omega$ " , "
R 142, 242	1-242-733-	330 k $\Omega$ " , "
R 143, 243	1-242-725-	150 k $\Omega$ " , "
R 144, 244	1-242-735-	390 k $\Omega$ " , "
R 145, 245	1-221-978-	4.7 k $\Omega$ (B), semi-fixed
R 146, 246	1-221-978-	4.7 k $\Omega$ (B), "
R 147, 247	1-242-681-	2.2 k $\Omega$ 1/4W, carbon
R 148, 248	1-242-701-	15 k $\Omega$ " , "
R 149, 249	1-242-705-	22 k $\Omega$ " , "
R 150, 250	1-242-693-	6.8 k $\Omega$ " , "
R 151, 251	1-242-711-	39 k $\Omega$ " , "
R 152, 252	1-242-657-	220 $\Omega$ " , "
R 153, 253	1-242-697-	10 k $\Omega$ " , "
R 154, 254	1-242-697-	10 k $\Omega$ " , "
R 155, 255	1-242-737-	470 k $\Omega$ " , "
R 156, 256	1-242-737-	470 k $\Omega$ " , "
R 157, 257	1-242-707-	27 k $\Omega$ " , "
R 158, 258	1-242-735-	390 k $\Omega$ " , "
R 159, 259	1-242-723-	120 k $\Omega$ " , "
R 160, 260	1-242-683-	2.7 k $\Omega$ " , "
R 161, 261	1-242-665-	470 $\Omega$ " , "
R 162, 262	1-242-713-	47 k $\Omega$ " , "
R 163, 263	1-242-673-	1 k $\Omega$ " , "
R 164, 264	1-242-691-	5.6 k $\Omega$ " , "
R 165, 265	1-242-709-	33 k $\Omega$ " , "
R 166, 266	1-242-737-	470 k $\Omega$ " , "
R 167, 267	1-242-681-	2.2 k $\Omega$ " , "
R 168, 268	1-242-685-	3.3 k $\Omega$ " , "
R 169, 269	1-222-306-	100 k $\Omega$ (A), variable
R 170, 270	1-242-725-	150 k $\Omega$ 1/4W, carbon
R 171, 271	1-221-978-	4.7 k $\Omega$ (B), semi-fixed
R 172, 272	1-221-748-	5 k $\Omega$ (B), "
R 173, 273	1-242-695-	8.2 k $\Omega$ 1/4W, carbon
R 174, 274	1-244-707-	27 k $\Omega$ " , "
R 175, 275	1-242-717-	68 k $\Omega$ " , "
R 176, 276	1-242-719-	82 k $\Omega$ " , "
R 177, 277	1-222-305-	20 k $\Omega$ (A), variable
R 178, 278	1-244-701-	15 k $\Omega$ 1/4W, carbon
R 301	1-242-657-	220 $\Omega$ " , "
R 302	1-242-649-	100 $\Omega$ " , "

<u>Symbol</u>	<u>Part No.</u>	<u>Description</u>
R303	1-244-688-	4.3 k $\Omega$ ¼W, carbon
R304	1-242-625-	10 $\Omega$ " , "
R305	1-242-625-	10 $\Omega$ " , "
R306	1-242-641-	47 $\Omega$ " , "
R307		- discarded -
R308		- discarded -
R309	1-221-664-	100 k $\Omega$ (B), semi-fixed
R310	1-242-719-	82 k $\Omega$ ¼W, carbon
R311	1-242-697-	10 k $\Omega$ " , "
R312	1-242-709-	33 k $\Omega$ " , "
R313	1-242-617-	4.7 $\Omega$ " , "

**JACKS**

J101, 201	1-507-142-13	auxiliary input
J102, 202	1-507-251-13	microphone input
J103, 203	1-507-142-13	line output
J301	1-507-282-11	headphone

**SWITCHES**

S101, 201	1-514-644-	equalizer
S102, 202	1-514-640-	monitor
S103, 203	1-514-641-	noise suppress
S104, 204	1-514-453-	record
S105, 205	1-514-643-	muting
S106, 206	1-514-642-	tape selector
S301	1-514-643-	bias on/off
S302	1-514-644-	equalizer
S303	1-514-655-	power on/off
S304	1-514-039-	automatic shut-off
S305	1-514-512-	frequency change
S306	1-514-041-	bias timing

**HEADS**

RH	8-824-629-20	record, RP102-2902
PH	8-829-129-20	playback, PP102-2902
EH	8-826-629-24	erase, EF18-2902A

<u>Symbol</u>	<u>Part No.</u>	<u>Description</u>
<b>MISCELLANEOUS</b>		
M	8-832-624-09	Motor, IC-624H1
ME	1-524-062-12	VU Meter
F	1-532-096-11	Fuse, 0.8 A
PL101, 201	1-518-093-21	Lamp, pilot
PL301	1-518-093-21	" , "
CN301	1-509-359-11	Connector, rec./p.b.
CP301	1-231-057-	Encapsulated Component, 0.033 $\mu$ F + 120 $\Omega$
CP302	1-101-534-	Encapsulated Component, 0.1 $\mu$ F + 120 $\Omega$
VS	1-509-064-13S	Voltage Selector
	1-539-387-11	Printed Circuit Board, record amp.
	1-539-388-12	Printed Circuit Board, playback amp.
	1-539-389-11	Printed Circuit Board, bias oscillator
	1-539-390-11	Printed Circuit Board, power supply
	1-508-396-11	Joint, terminal (white)
	1-508-396-21	" , " (yellow)
	1-509-367-11	" , " (white)
	1-509-367-21	" , " (yellow)
	1-534-487-22	Cord, power
	1-536-179-11	Terminal Strip, 1-L-1 (C type)
	1-536-146-11	Terminal Strip, 1-L-1 (A type)
	1-536-180-11	Terminal Strip, 1-L-2 (C type)
	1-536-181-11	Terminal Strip, 2-L-1 (C type)
	1-533-006-11	holder, fuse

## 15. EXPLODED VIEW

### 15-1. Packing

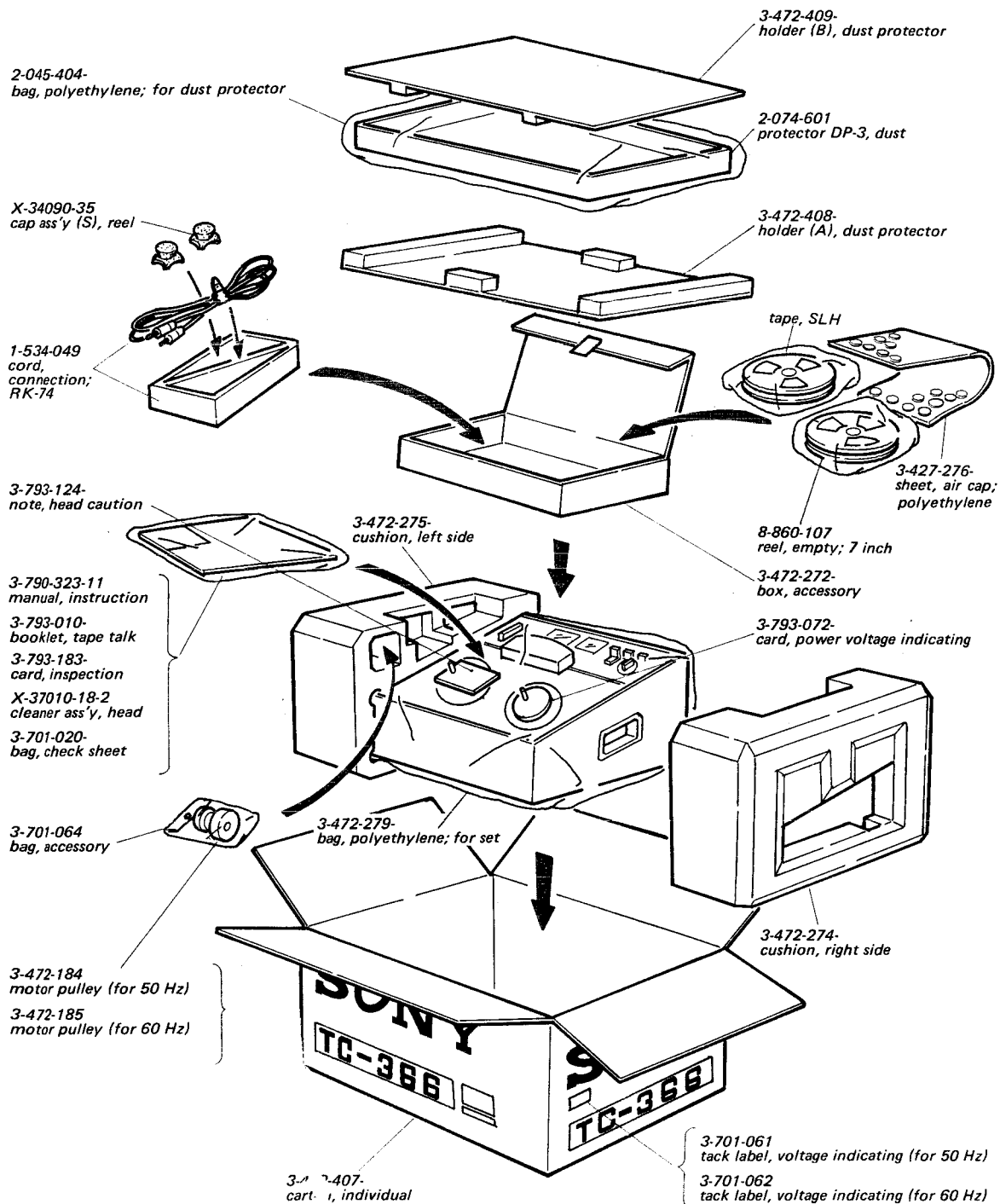



15-2. Cabinet — top view —

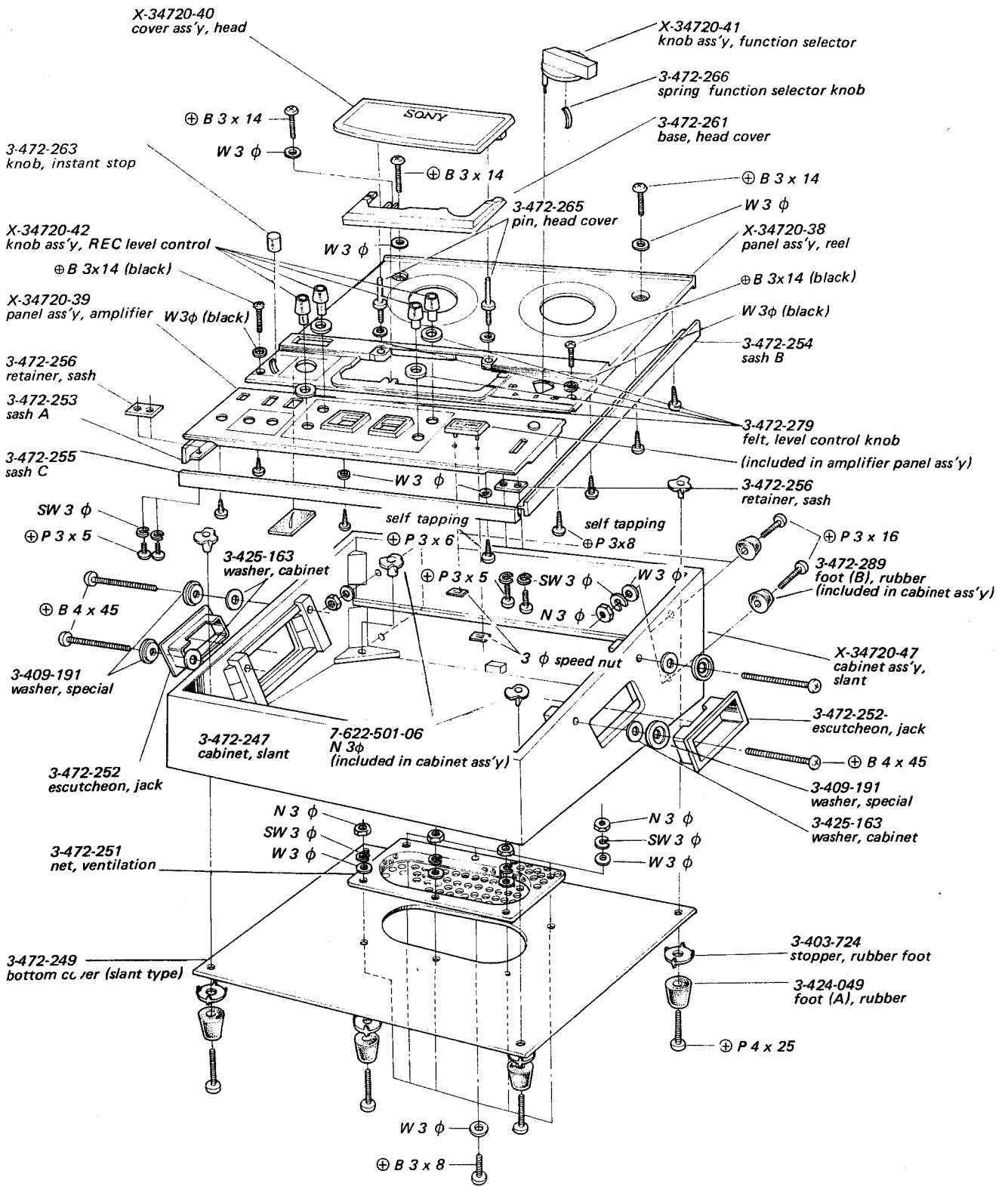





15-5. Head Deck — top view —

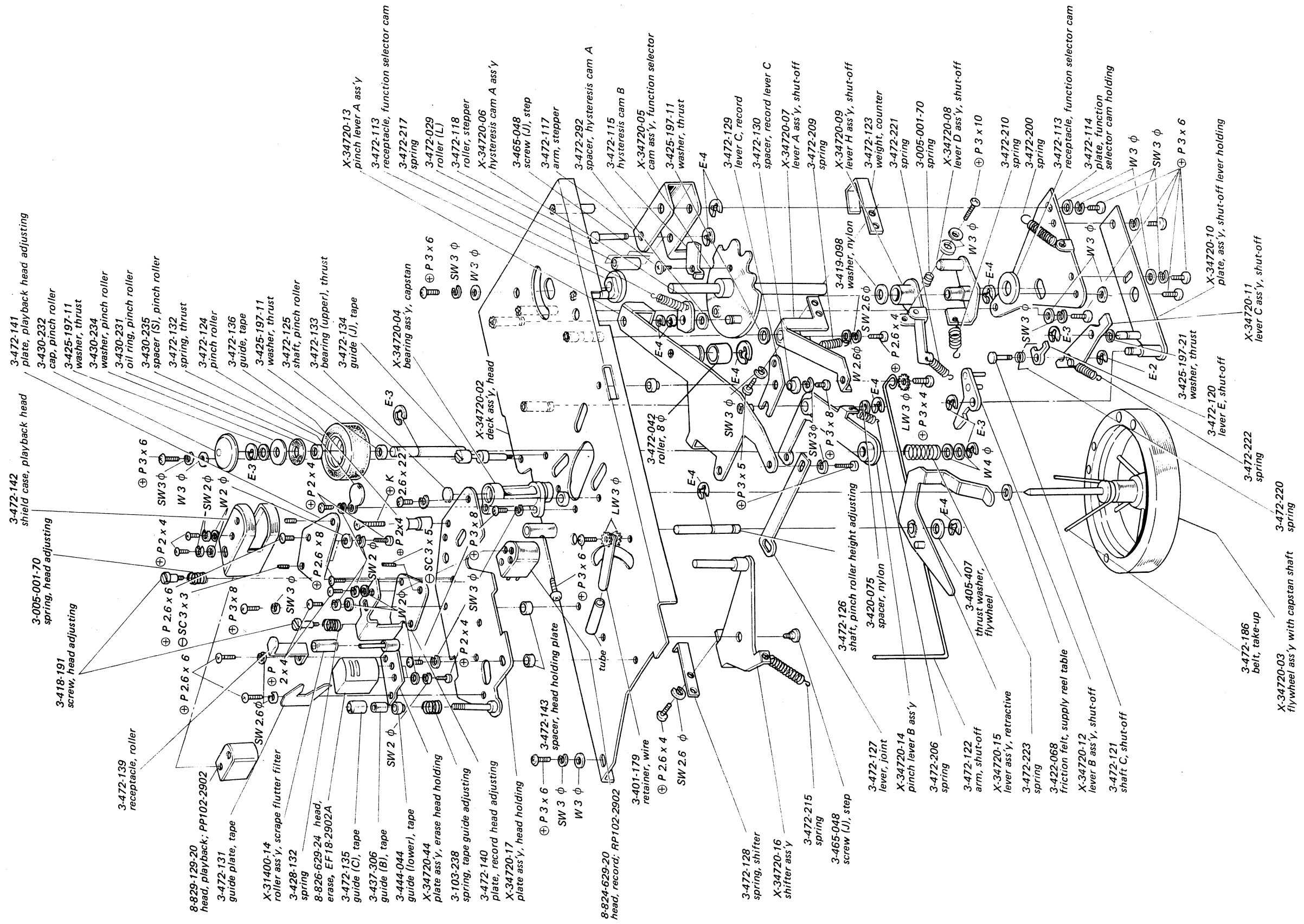





16. HARDWARES

<u>Part No.</u>	<u>Description</u>	<u>Part No.</u>	<u>Description</u>
<b>Screws</b>			
	⊕ PS 2.6 × 4	7-621-259-72	⊕ P 2.6 × 12
	⊕ PS 2.6 × 6	7-621-560-52	⊕ K 2.6 × 22
	⊕ PS 2.6 × 10	7-621-771-35	⊕ B 2.6 × 6
		7-621-771-38	⊕ B 2.6 × 8
7-682-145-01	⊕ P 3 × 4		
7-682-147-01	⊕ P 3 × 6		
7-682-148-01	⊕ P 3 × 8		
7-682-149-01	⊕ P 3 × 10		
7-682-150-01	⊕ P 3 × 12		
7-682-160-01	⊕ P 4 × 6		
7-682-161-01	⊕ P 4 × 8		
7-682-167-01	⊕ P 4 × 25		
7-682-547-13	⊕ B 3 × 6		
7-682-548-13	⊕ B 3 × 8		
7-682-549-13	⊕ B 3 × 10		
7-682-550-14	⊕ B 3 × 12		
7-682-562-13	⊕ B 4 × 10		
7-682-571-14	⊕ B 4 × 45		
7-682-624-00	⊕ PS 2 × 4		
7-682-627-00	⊕ PS 2 × 8		
7-682-646-00	⊕ PS 3 × 5		
7-682-647-00	⊕ PS 3 × 6		
7-682-648-00	⊕ PS 3 × 8		
7-682-652-00	⊕ PS 3 × 16		
7-682-660-00	⊕ PS 4 × 6		
7-682-661-00	⊕ PS 4 × 8		
7-683-140-01	⊖ SC 3 × 6		
7-685-145-21	⊕ P 3 × 6 (self tapping)		
7-685-146-21	⊕ P 3 × 8 (self tapping)		
7-621-259-42	⊕ P 2.6 × 6		
7-621-259-52	⊕ P 2.6 × 8		
7-621-259-62	⊕ P 2.6 × 10		
<b>Nuts</b>			
		7-622-108-02	N 3 φ
		7-622-501-06	N 4 φ (with claw)
<b>Washers</b>			
		7-623-105-12	W 2 φ
		7-623-107-02	W 2.6 φ (small)
		7-623-108-02	W 3 φ (small)
		7-623-107-22	W 2.6 φ
		7-623-108-12	W 3 φ
		7-623-108-18	W 3 φ
		7-623-110-02	W 4 φ (small)
		7-623-110-12	W 4 φ
		7-623-113-12	W 6 φ
		7-623-208-22	SW 3 φ
			W 8 φ (wave)
		7-623-408-05	LW 3 φ
<b>Retaining Rings</b>			
		7-624-109-01	E-2
		7-624-106-01	E-3
		7-624-108-01	E-4
		7-624-109-01	E-5
		7-624-110-01	E-6
		7-624-111-01	E-7
		7-624-112-01	E-8

— Hardware Nomenclature —

<p><b>P</b> — Pan Head Screw ..... </p> <p><b>PS</b> — Pan Head Screw with Spring Washer ..... </p> <p><b>K</b> — Flat Countersunk Head Screw ... </p> <p><b>B</b> — Binding Head Screw ..... </p> <p><b>RK</b> — Oval Countersunk Head Screw ... </p> <p><b>T</b> — Truss Head Screw ..... </p> <p><b>R</b> — Round Head Screw ..... </p> <p><b>F</b> — Flat Fillister Head Screw ..... </p>	<p><b>SC</b> — Set Screw ..... </p> <p><b>E</b> — Retaining Ring (E Washer) ..... </p> <p style="margin-left: 20px;">W — Washer</p> <p style="margin-left: 20px;">SW — Spring Washer</p> <p style="margin-left: 20px;">LW — Lock Washer</p> <p style="margin-left: 20px;">N — Nut</p> <p>— Example —</p> <p></p>
---	--

**TC-366**

**SONY CORPORATION**