

SONY®

TA-N7B

Power Amplifier

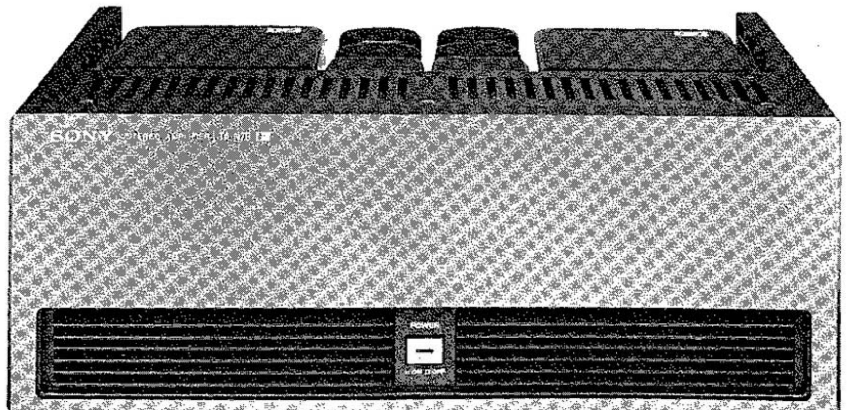

**new circuit
operation**

SONY INDUSTRIES

Hi-Fi Technical Support

47-47 Van Dam Street, Long Island City, New York 11101

PRINTED IN U.S.A.
2H990 1078 -1

TABLE OF CONTENTS

INPUT AMPLIFIER.....	2
POWER OUTPUT STAGE.....	5
PROTECTION CIRCUITS.....	7
POWER SUPPLY.....	10

Input Amplifier

A dual FET (Q105) and a pair of discrete FETs (Q103 and Q104) are connected as a differential cascode amplifier (Fig. 1). As such, the loads for the drains of Q105 are the very low input impedance of Q103 and Q104 in the common-gate configuration. High values of Miller-effect capacitance, which could affect the high-frequency stability of the feedback input, will therefore not develop. Since the input device uses the common-source configuration, a dual FET is used instead of two discrete FETs so the halves will be perfectly matched and track each other as the temperature changes. The entire power amplifier is DC coupled, so drift minimization is important.

Signal is applied to gate G1 of input transistor Q105 either directly or through a coupling capacitor. Resistor R102 is a parasitic-oscillation suppressor that also forms a low-pass filter in conjunction with capacitor C112 to filter out RFI. The other gate (G2) of transistor Q105 is used as the negative feedback input. Feedback resistors R111 and R113 set the amplifier voltage gain at approximately 25X. Capacitor C107 across R113 is high-frequency feedback compensation. An active current source (Q106) provides high common-mode rejection and balance for the differential input stage. However, pot RV101 does allow setting a slight differential in source voltage between the two halves of Q105 to effect DC balance at the output point of the power amplifier.

Transistor Q101 is an active load for the drain of Q103. The extremely high impedance provided by an active load yields the maximum possible gain in the input stage. Transistor Q101 is biased by the voltage drop across diode-connected transistor Q102 and resistor R108. The current flow through these components is provided by the drain of Q104, which acts as a constant-current source for maximum bias stability. A series RC network across the Q103 and Q104 drains provides phase compensation for high-frequency stability in the presence of heavy negative feedback.

Transistors Q109 and Q110 form a cascode amplifier. Since Q109 has a voltage gain of about 1, its input capacitance is quite low and will not capacitively-load the input stage. Diode string D101 and D102 bias the common-base transistor (Q110) that provides the voltage gain. This transistor is a major contributor to the open-loop voltage gain of the TA-N7B, since it uses transistor Q111 as an active load.

The Q109, Q110, Q111 current path includes the bias components for the output transistor's Class B drivers. Diode D103 contains four silicon junctions in series; pot RV102 precisely trims the bias voltage dropped across this diode and resistor R128.

Bias for current-source Q106 and Q111 is provided by transistors Q107 and Q108. These transistors form a classic feedback-type series voltage regulator, where Q107 is the series pass transistor, and Q108 is the error detector and amplifier. (This is more apparent if you look at the simplified schematic, Fig. 2.) Resistors R114 and R115 form a voltage divider across the output of the regulator (the emitter of Q107) to monitor the bias supplied to the

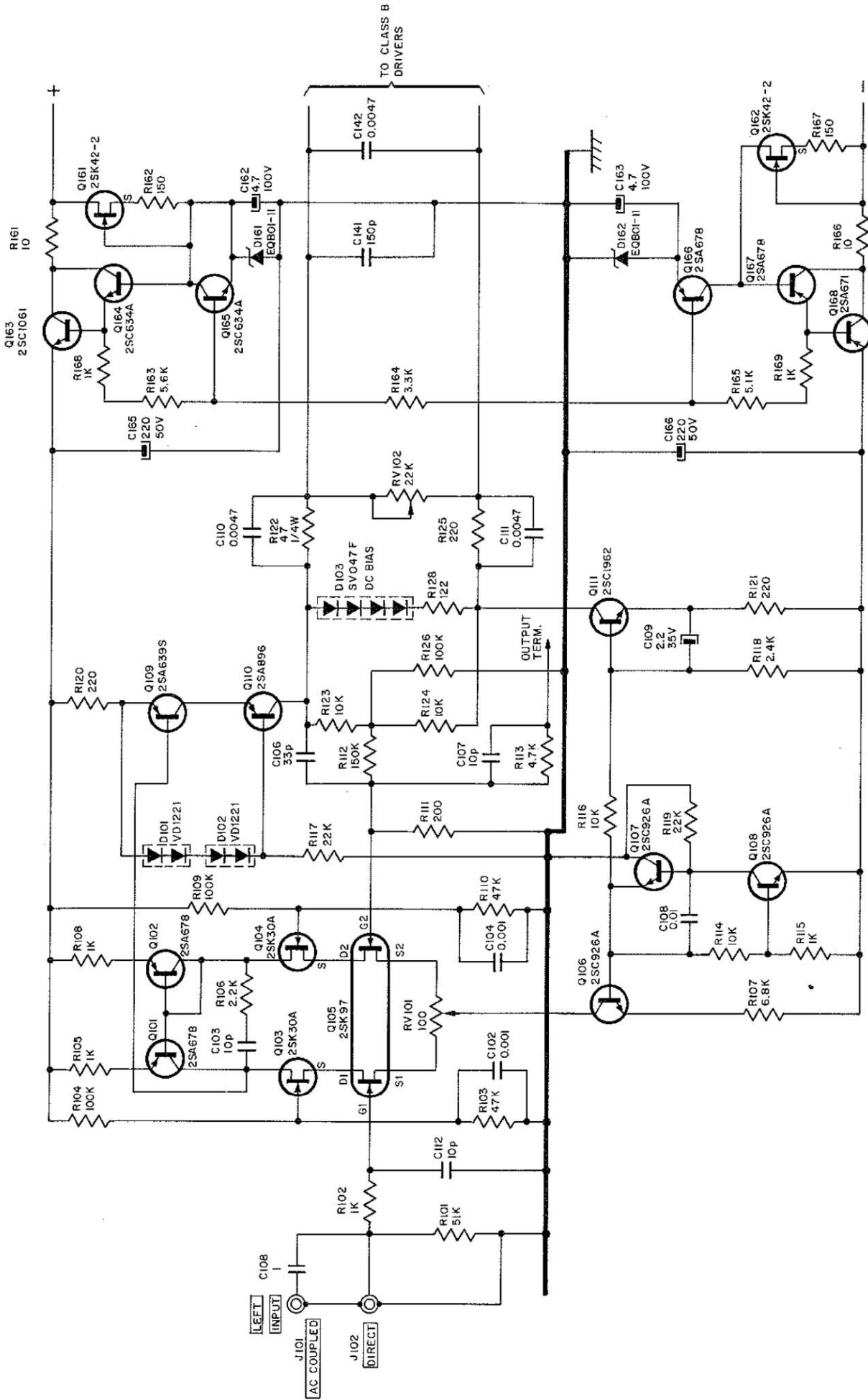

Fig. 1. TA-N7B Input Amplifier

current sources. Note that since Q106 needs only a few volts across it to handle the small signal level at the input amplifier, current source Q106 uses a high value emitter resistor and receives the full regulator output voltage at its base. However, current source Q111 must have a very large voltage drop across it to handle the very large output voltage swings of the TA-N7B, so a small value emitter resistor (R121) is used and only a portion of the bias-regulator output voltage is supplied to the base of Q111 through voltage divider R116/R118.

Voltage Regulators. Regulators for the input stages are mounted right on the main power-amp board. These regulators are conventional lossier-type series regulators with two fairly new features. First, a resistor (R164) common to both positive and negative supplies is used in the voltage divider in lieu of separate resistors connected to ground. This allows the regulators to track (i.e., drift higher or lower by the same amount) with temperature. Second, the collector resistors for the error-amplifier transistors have been replaced with FET current sources (Q161 for the positive regulator, Q162 for the negative regulator) for superior regulation.

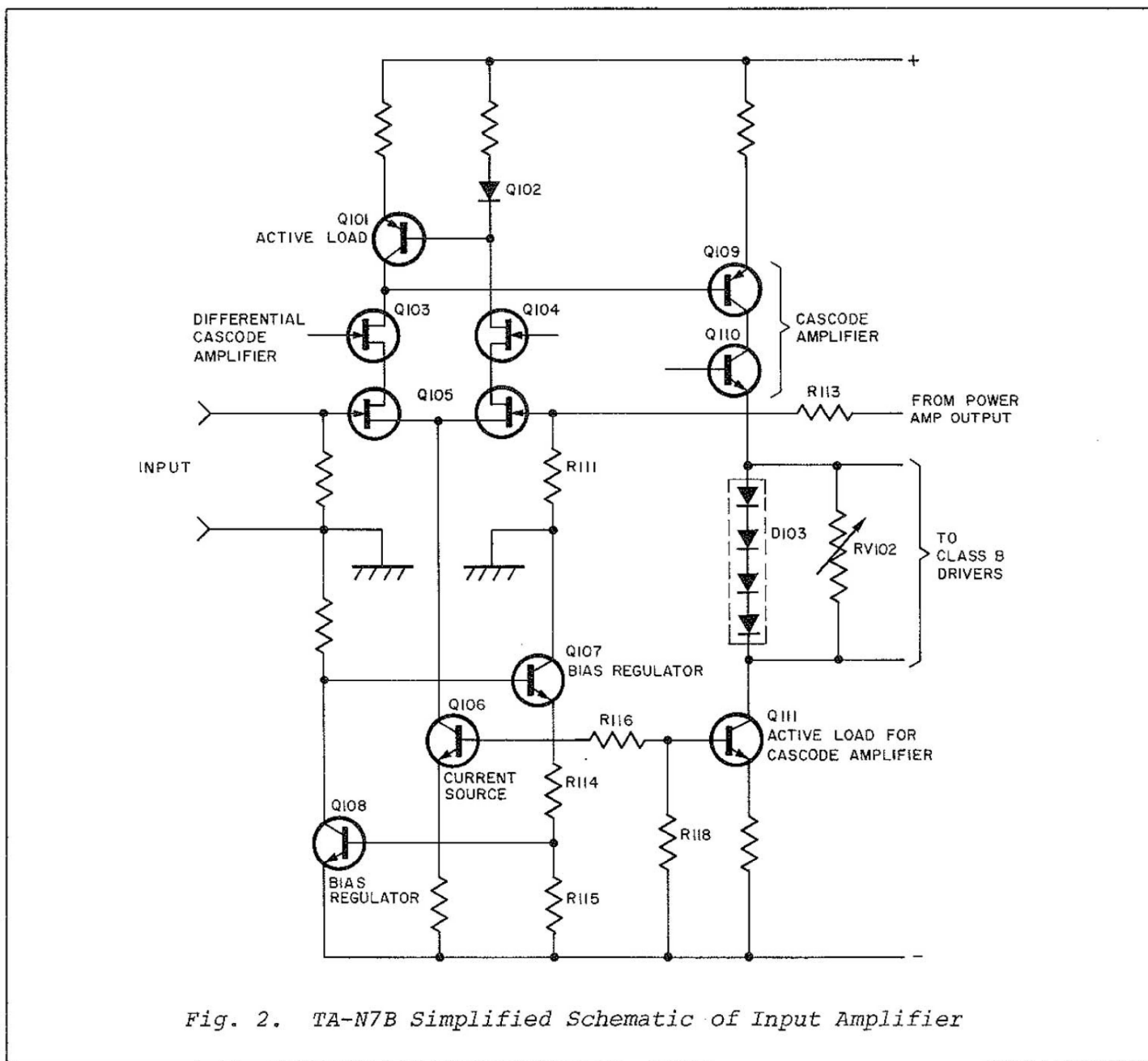

Fig. 2. TA-N7B Simplified Schematic of Input Amplifier

Power Output Stage

The positive and negative halves of the output stage each consist of three parallel-connected combinations of power devices (Fig. 3). Each power-device combination consists of a high-power VFET and medium-power bipolar transistor connected in a cascode configuration. This makes a total of 12 transistors in the output stage; six VFETs (Q132-Q134 and Q141-Q143), and six bipolar transistors (Q135-Q140).

The cascode combination of VFET and bipolar transistor provides increased efficiency, improved performance, greater serviceability and reliability. The reason for this, and the operation of the output stage, can be understood by using the simplified schematic diagram in Fig. 4. The VFET and bipolar transistor are connected as a cascode amplifier with the VFET driven by the bipolar transistor. Notice that the VFET gate is connected at the far end of the bipolar transistor's current equalizing resistor. This means that the bipolar transistor determines the current flow through the

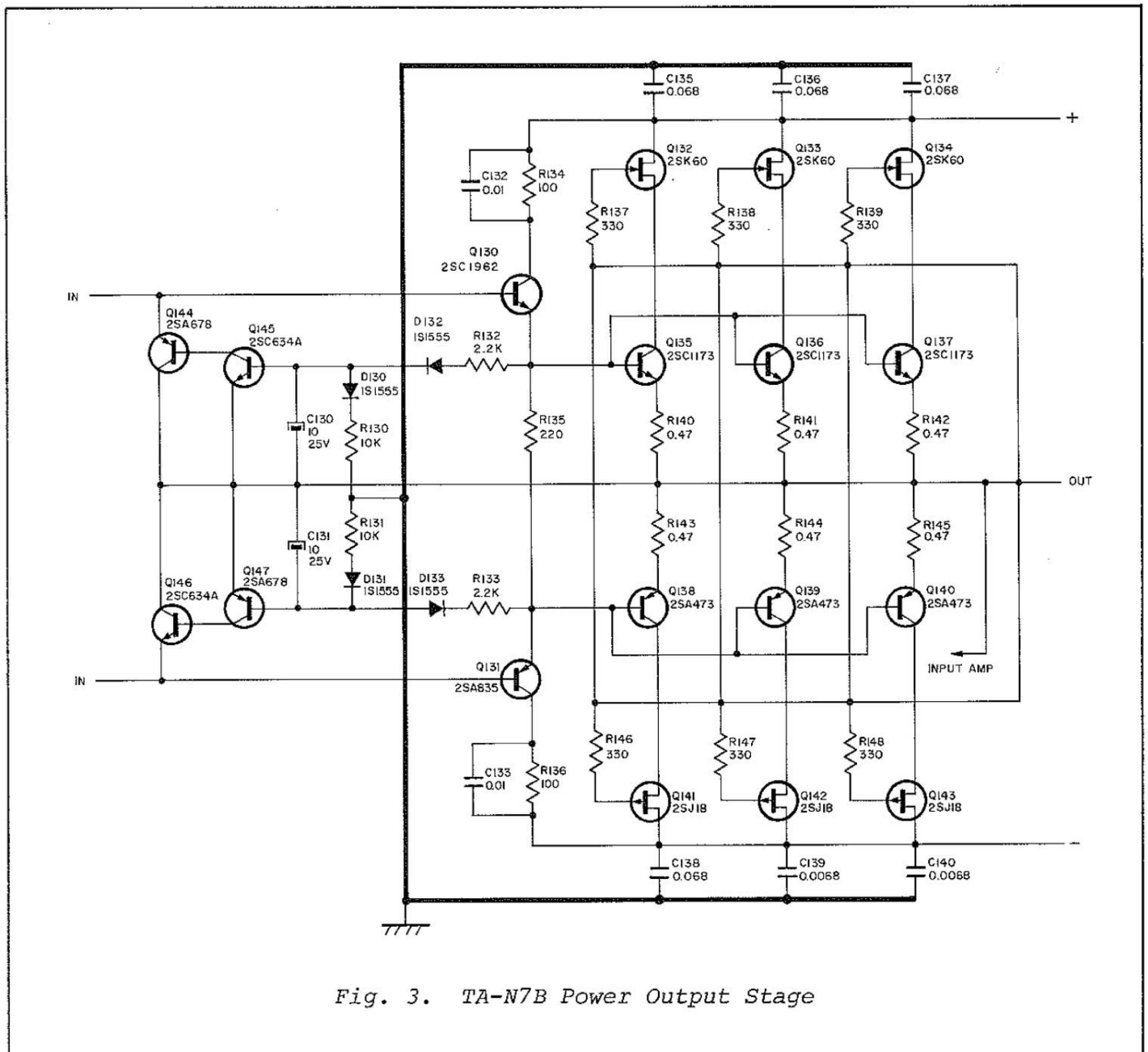

Fig. 3. TA-N7B Power Output Stage

series combination of the two transistors. Since the current in bipolar transistors can be well equalized with a small value (0.5 ohm) resistor, these combinations can be connected in parallel with excellent current sharing, but without the need for the perfect matches previously required of VFETs. The voltage drop across the bipolar transistor becomes whatever VFET gate-source voltage is required for the drain current set by the bipolar transistors. This same action makes the operating point of the cascode combination independent of power-supply voltage, so voltage changes due to heavy load current or a drop in power-line voltage have little effect. Thus the TA-N7B does not need well-regulated power supplies or the bias-correction circuitry of previous VFET amplifiers to achieve super-low distortion levels. Moreover, eliminating the old automatic bias-correction circuitry also eliminates the need for supply voltages higher than that provided to the power transistors.

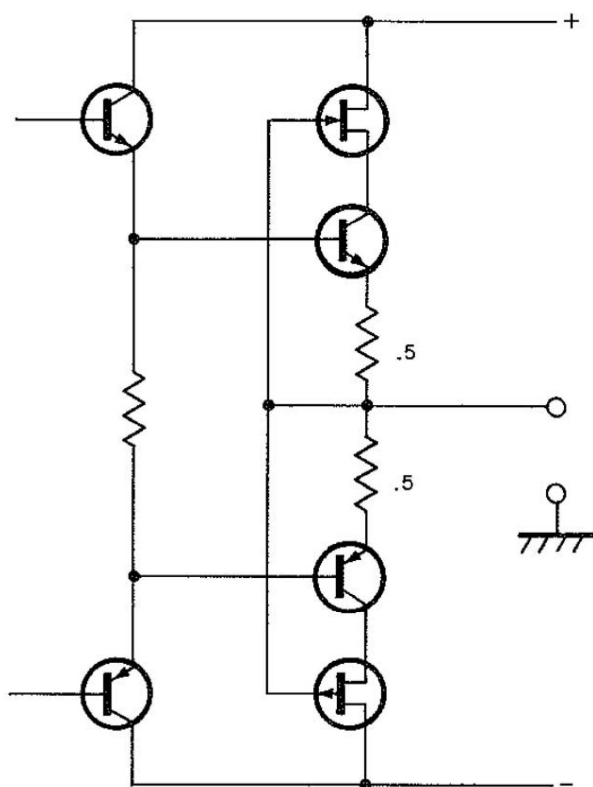

Fig. 4. TA-N7B Simplified Schematic of Power-Output Stage

Protection Circuits

Overdrive protection for the TA-N7B is provided by the circuit built around transistors Q144-Q147 (Fig. 3). This circuit functions because the collector of a Class B amplifier increases with increased AC drive. In the TA-N7B, the DC collector/emitter current of the Class B drivers (Q130 and Q131) is monitored via the voltage drop across resistor R135. During overdrive, the DC voltage at the emitter of transistor Q130 begins to exceed +1.2 volts, and the voltage at the emitter of Q131 begins to exceed -1.2 volts. These voltage levels are the sums of the barrier potentials for the base-emitter junction of transistor Q145 and diode D132, and transistor Q147 and diode D133. Past these levels, these junctions conduct, turning on transistors Q145 and Q147. Their conduction turns on transistors Q144 and Q146. Since these transistors bridge the input to the Class B drivers, their now low collector-emitter resistance shunts signal current around the input to the Class B drivers, limiting the drive level, hence the current level in the output transistors.

Thermal protection of the power transistors is provided by a positive-temperature-coefficient transistor (PTh151) attached to the case of power transistor Q141. This thermistor is in the bias path of transistor Q154 in the speaker-protection circuit (Fig. 5). If the power transistor overheats from excessive current flow (whether caused by overdrive or excessively low load impedance), the resistance of the thermistor will increase greatly. This will reduce the base current of Q154, hence the collector current of relay-drive transistor Q154, below the drop-out point the relay. The relay will then open and remove the load from the amplifier.

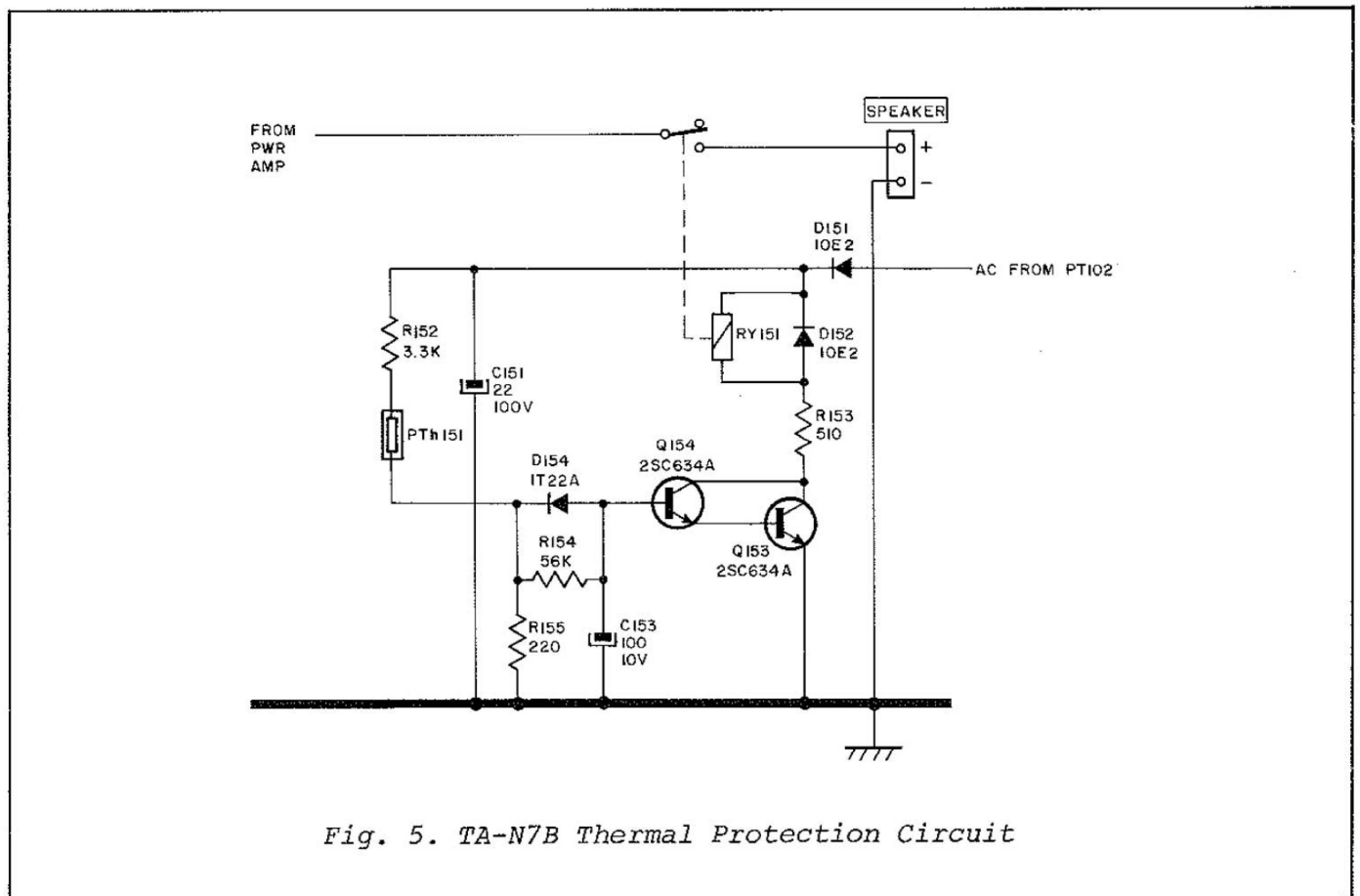

Fig. 5. TA-N7B Thermal Protection Circuit

Speaker Protection. Any DC voltage appearing at the amplifier output terminal is coupled to the bases of transistors Q151 and Q152 through resistor R151 (Fig. 6). Because capacitor C152 forms a low-pass filter of long time constant in conjunction with R151, AC signal voltage will not activate the speaker protection circuit.

If a positive DC voltage appears, transistor Q151 will conduct and short the base of relay-driver transistor Q154 to near ground. Q154 is connected in the Darlington configuration with transistor Q153, so dropping Q154's base voltage below 1.2 volts cuts off these transistors. Loss of collector current in Q153/Q154 de-energizes speaker relay RY151, opening its contacts and thereby disconnecting the speaker line from the amplifier.

If a negative DC voltage appears at the amplifier output point, transistor Q152 will conduct and similarly ground the base of transistor Q154.

Other parts in this same circuit protect the speakers from turn-on and turn-off transients. When the TA-N7B is first turned on, AC from power transformer PT102 is rectified by diode D151 and immediately charges filter capacitor C151. Turn-on bias is applied to the base of relay-driver transistor Q154 through resistor R152, thermistor PTh151, and resistor R154. However, capacitor C153 forms a long time constant in conjunction with the aforementioned resistor, so there is a delay before the base voltage of transistor Q154 reaches the 1.2 volts needed for conduction and energizing of the speaker relay. This delay allows the operating voltages in the amplifier circuitry to come up to their full levels and stabilize before the speakers are connected.

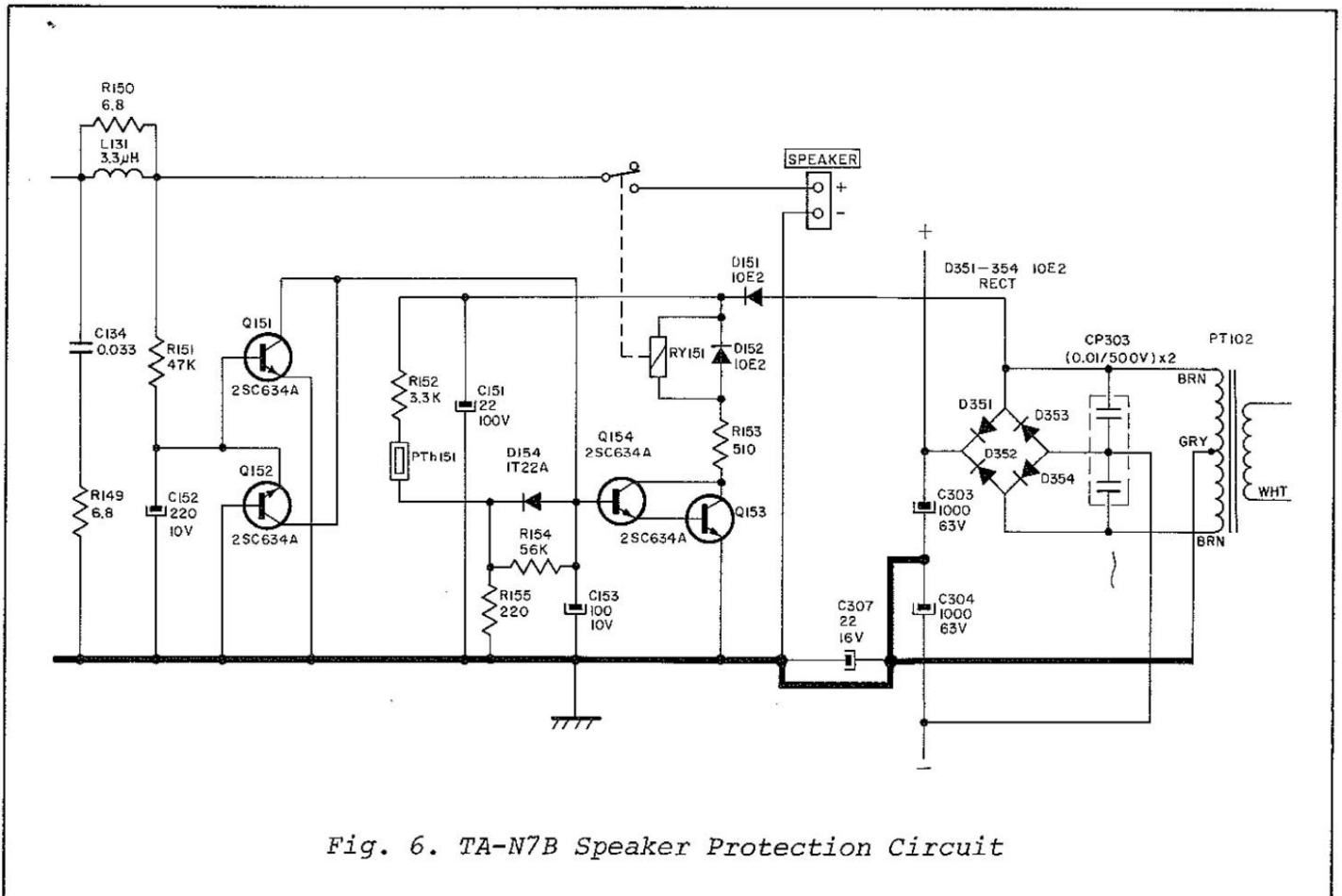

Fig. 6. TA-N7B Speaker Protection Circuit

The speakers are protected against turn-off transients because the same circuit disconnects the speaker lines from the amplifier output before the amplifier voltages can drop very much. The filter/energy-storage capacitors in the main power supply are very large so as to maintain the circuit voltage steady with sustained low-frequency notes, so the amplifier circuit voltages will decay relatively slowly when the TA-N7B power switch is turned off. However, the filter capacitor in the speaker-protection circuit power supply is small and discharges very rapidly through R152, PTh151, and R155 when the power supply is turned off. This removes the supply voltage from Q154's base bias circuit. As soon the voltage across resistor R155 (the supply point for base bias resistor R154) drops below 0.8 volts, germanium diode D154 begins to conduct and thereby rapidly discharges capacitor C153. The net result is that base bias is quickly removed from Q154 after the TA-N7B power switch is turned off, so the speaker lines are disconnected before the main power-supply voltages decay.

Power Supply

Separate power supplies are used for each channel, and within each of these separate power supplies, separate power transformers and filter capacitors are used for the power-output stage and the voltage amplifier stages. However, the TA-N7B power switch is common to all these power supplies, and current-limiting resistors (R501 and R502) are needed to limit the initial surge current to a level the switch can handle. These resistors are shorted out by contacts on relay RY501 after the initial surge. The delay is provided by the time constant of the RC circuit containing resistors R504-R506 and capacitor C501. When the power switch is closed, DC voltage appears across filter capacitor C151 in the speaker-protection circuit. This voltage is also supplied to the surge-control relay through resistor R507, and to the base-bias resistors for transistor Q501. This transistor and Q502 form a Darlington-connected transistor that is the ground return for relay RY501. When DC appears across filter capacitor C151, capacitor C501 begins to charge through resistors R504 and R506. When the voltage across C501 exceeds 1.2 volts, Q501/Q502 turns on. This closes the DC path that energizes relay RY501 and shorts out R501 and R502.

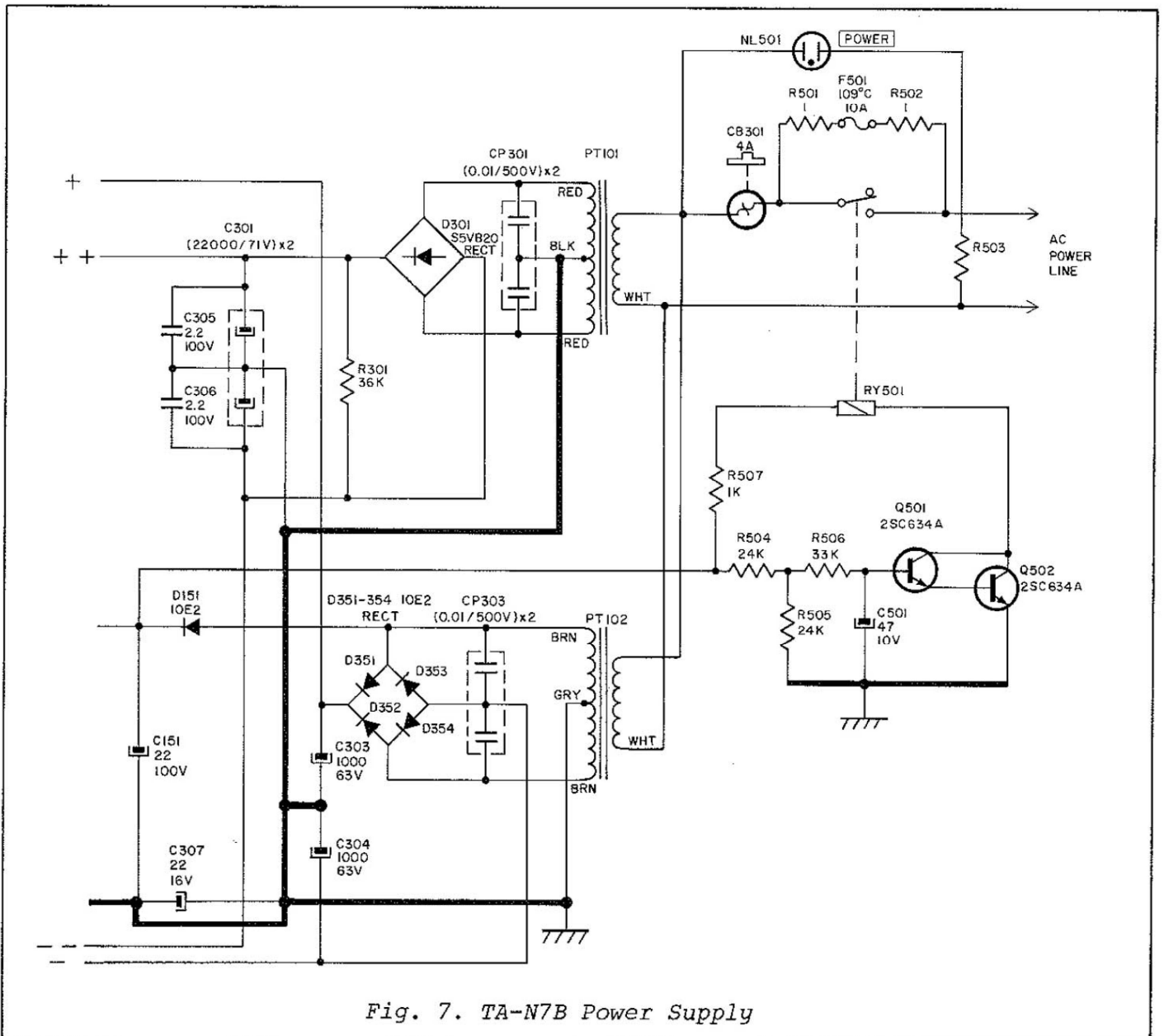

Fig. 7. TA-N7B Power Supply

