

TA-N7/N7B

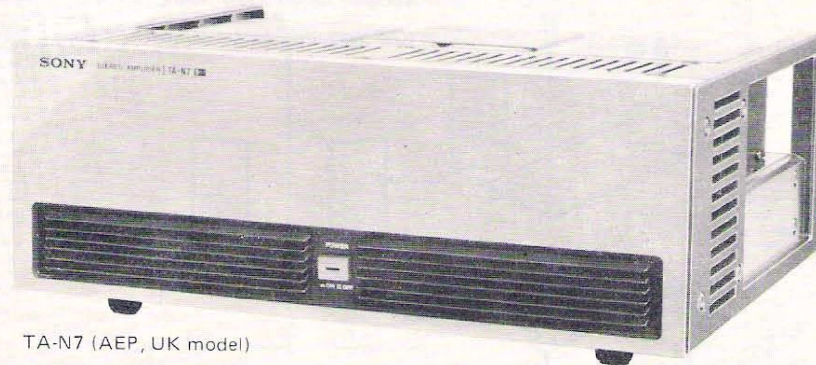

TA-N7 (AEP, UK model)

TA-N7 (Panel: Silver)

AEP Model

UK Model

TA-N7B (Panel: Black)

AEP Model

UK Model

US Model

Canadian Model

STEREO POWER AMPLIFIER

SPECIFICATIONS

GENERAL

Power Requirements:	240V ac, 50/60Hz (UK model) 220V ac, 50/60Hz (AEP model) 120V ac, 60Hz (US, Canadian model)
Power Consumption:	480W (UK model) 420W (AEP model) 160W (US model) 350VA (Canadian model)
Dimensions:	Approx. 430(W) x 170(h) x 335(d) mm 17(w) x 6¾(h) x 13¼(d) inches Including projecting parts and controls
Weight:	(UK, AEP model) Approx. 20.1kg, 44 lb 5 oz (net) Approx. 22.6kg, 49 lb 14 oz (with shipping carton) (US, Canadian model) Approx. 21kg, 46 lb 5 oz (net) Approx. 23.6kg, 52 lb 1 oz (with shipping carton)

SAFETY-RELATED COMPONENT WARNING !!

COMPONENTS IDENTIFIED BY SHADING AND  MARK ON THE SCHEMATIC DIAGRAMS, EXPLODED VIEWS AND IN THE PARTS LIST ARE CRITICAL TO SAFE OPERATION. REPLACE THESE COMPONENTS WITH SONY PARTS WHOSE PART NUMBERS APPEAR AS SHOWN IN THIS MANUAL OR IN SUPPLEMENTS PUBLISHED BY SONY.

ATTENTION AU COMPOSANT AYANT RAPPORT À LA SÉCURITÉ !

LES COMPOSANTS IDENTIFIÉS PAR UN TRAMÉ ET UNE MARQUE  SUR LES DIAGRAMMES SCHEMATIQUES, LES VUES EXPLOSÉES ET LA LISTE DES PIÈCES SONT CRITIQUES POUR LA SÉCURITÉ DE FONCTIONNEMENT. NE REMPLACER CES COMPOSANTS QUE PAR DES PIÈCES SONY DONT LES NUMÉROS SONT DONNÉS DANS CE MANUEL OU DES SUPPLÉMENTS PUBLIÉS PAR SONY.

—Continued on page 2—

SONY[®]
SERVICE MANUAL

TA-N7/N7B

POWER AMPLIFIER SECTION

Continuous RMS Power Output: Both channels driven simultaneously
(Less than 0.01% THD) At 20–20,000 Hz
100W + 100W (8Ω)
According to DIN 45500 (AEP, UK model)
100W + 100W (8Ω)

Power Bandwidth: 5–35,000 Hz (8Ω), IHF (AEP, UK model)

Damping Factor: 100 (8Ω, 1kHz)

Harmonic Distortion: Less than 0.01% at rated output
Less than 0.008% at 1W/10W output

Less than 0.01% at 250mW—rated output
(US, Canadian model)

IM Distortion: Less than 0.01% at rated output
(60Hz: 7kHz = 4:1) Less than 0.008% at 1W/10W output

Frequency Response: DC–100,000Hz ± 0 dB (DIRECT INPUT)
6–100,000Hz ± 0 dB (C COUPLED INPUT)

S/N Ratio: Greater than 120 dB, short-circuited input

Residual Noise: Less than 0.024mV (8Ω) weighting network A

Inputs:	Sensitivity	Impedance
DIRECT		
C COUPLED (3Hz cut-off frequency)	1.3V (for rated output)	50kΩ

Outputs: SPEAKER terminals:
Accept speakers of 8Ω or more

MODEL IDENTIFICATIONS

– Specification Label –

AEP model (TA-N7)

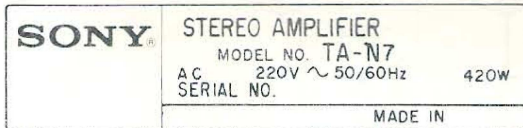

UK model (TA-N7)

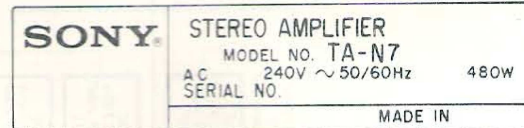

AEP model (TA-N7B)

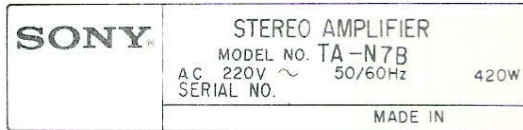

UK model (TA-N7B)

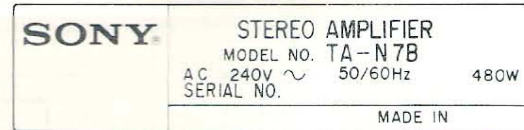

US model (TA-N7B)

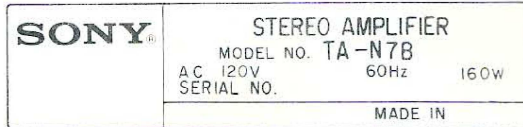

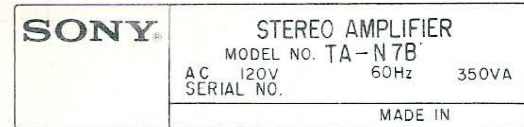

Canadian model (TA-N7B)



SERVICING NOTES

- This set uses bipolar transistors and V-FETs in cascade circuit to maintain stable biasing. When replacing the three P-channel V-FETs 2SK60 and/or the three N-channel V-FETs 2SJ18 in each channel, use three matched ones which have the same Vp (pinch-off voltage)-rank figure printed on them as shown below. The fluctuation of the Vp rank of the three can be acceptable on one-rank-difference basis.
- Two kinds of hexagonal-socket screw-drivers are required for the following removal.

 2.5mm : top cover removal

 4mm : side plate removal

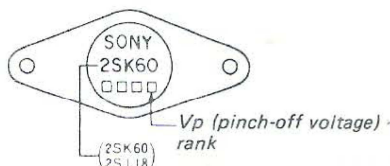

SECTION 1
OUTLINE

1-1. BLOCK DIAGRAM

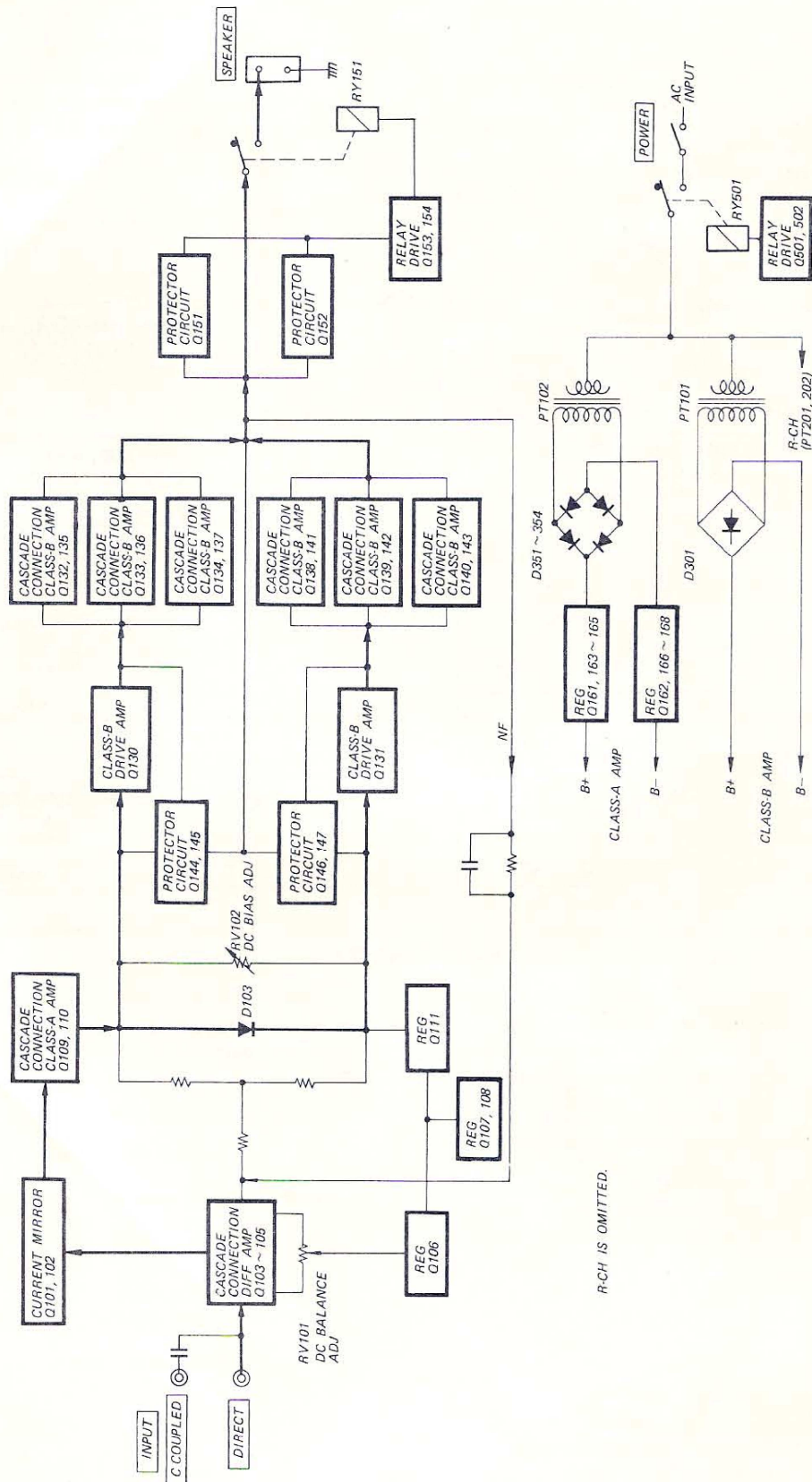

R-CH IS OMITTED.

SECTION 2 DISASSEMBLY

Remove the parts in the numerical order.

FRONT PANEL REMOVAL

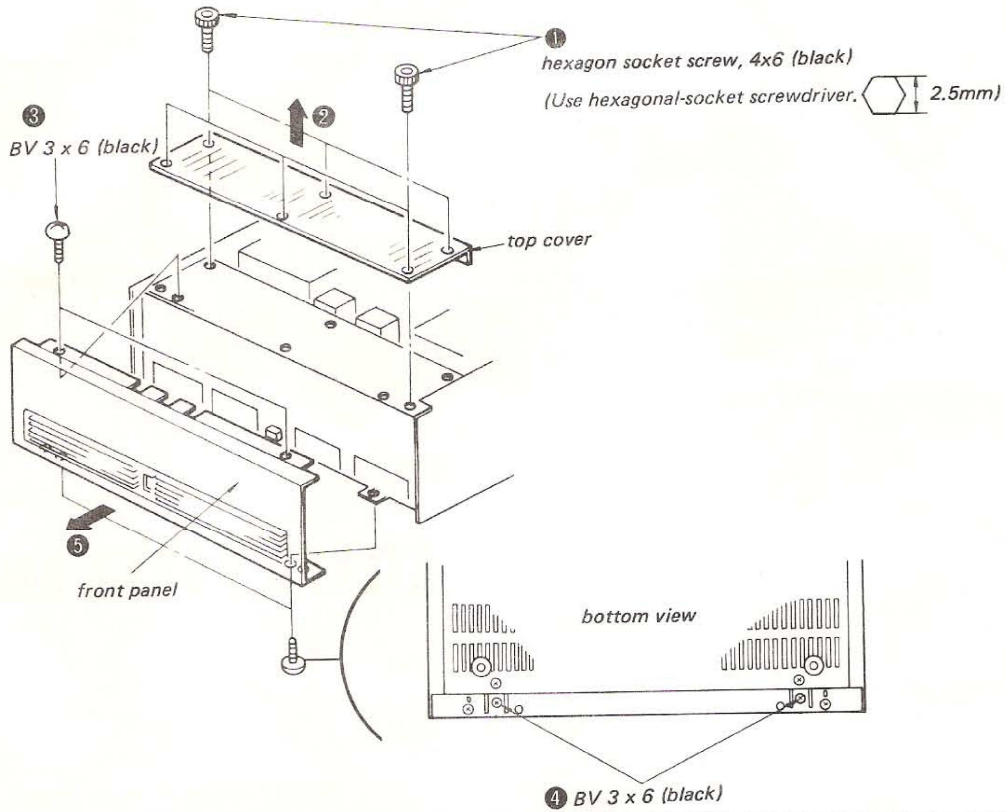

BOTTOM PLATE AND HEAT SINK REMOVAL

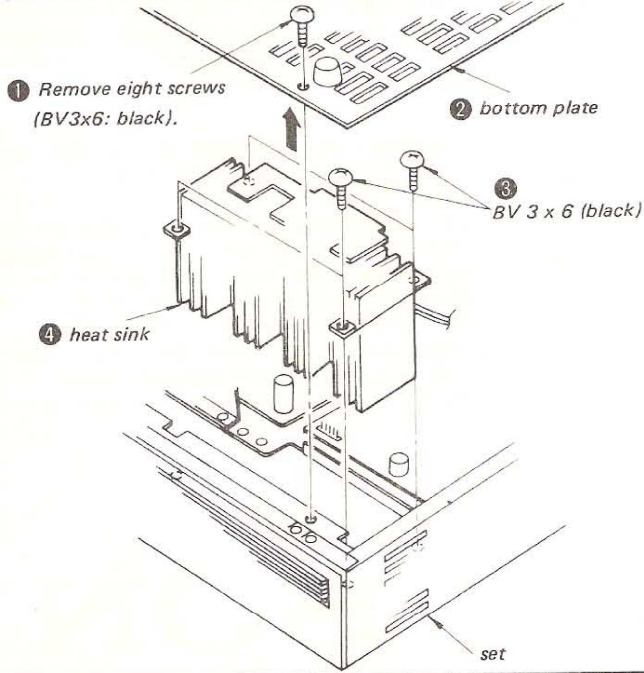

SECTION 3 ADJUSTMENT

Note:

1. Apply the rated ac line voltage to the set directly. Do not increase the voltage gradually by using a variable transformer or other such instrument; this will cause a V-FET failure.
2. Turn the set on and wait a few minutes for warm-up.
3. Alternately repeat the two adjustments 2 or 3 times.

DC Balance Adjustment

Adjust RV101(L-CH) and RV201 (R-CH) for 0V dc with no signal input.

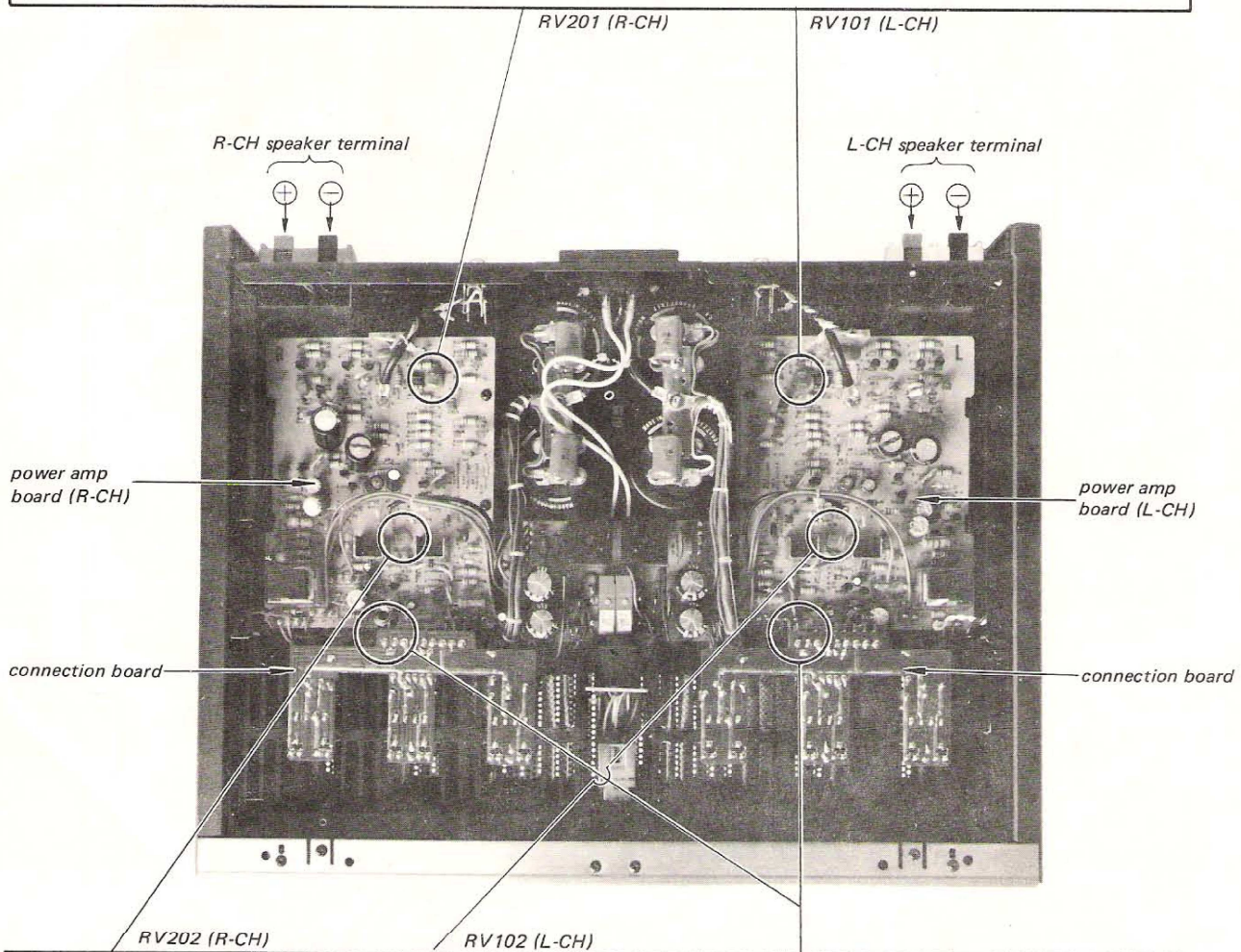
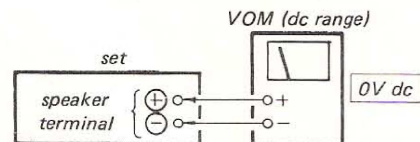

DC Bias Adjustment

Adjust RV102 (L-CH) and RV202 (R-CH) for 30–70 mV dc with no signal input.

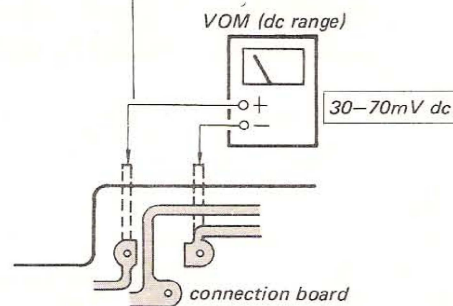

SECTION 4
DIAGRAMS

4-1. MOUNTING DIAGRAM – L-CH Power Amp Board –
– Conductor Side –

• Replacement Semiconductors: See page 8.

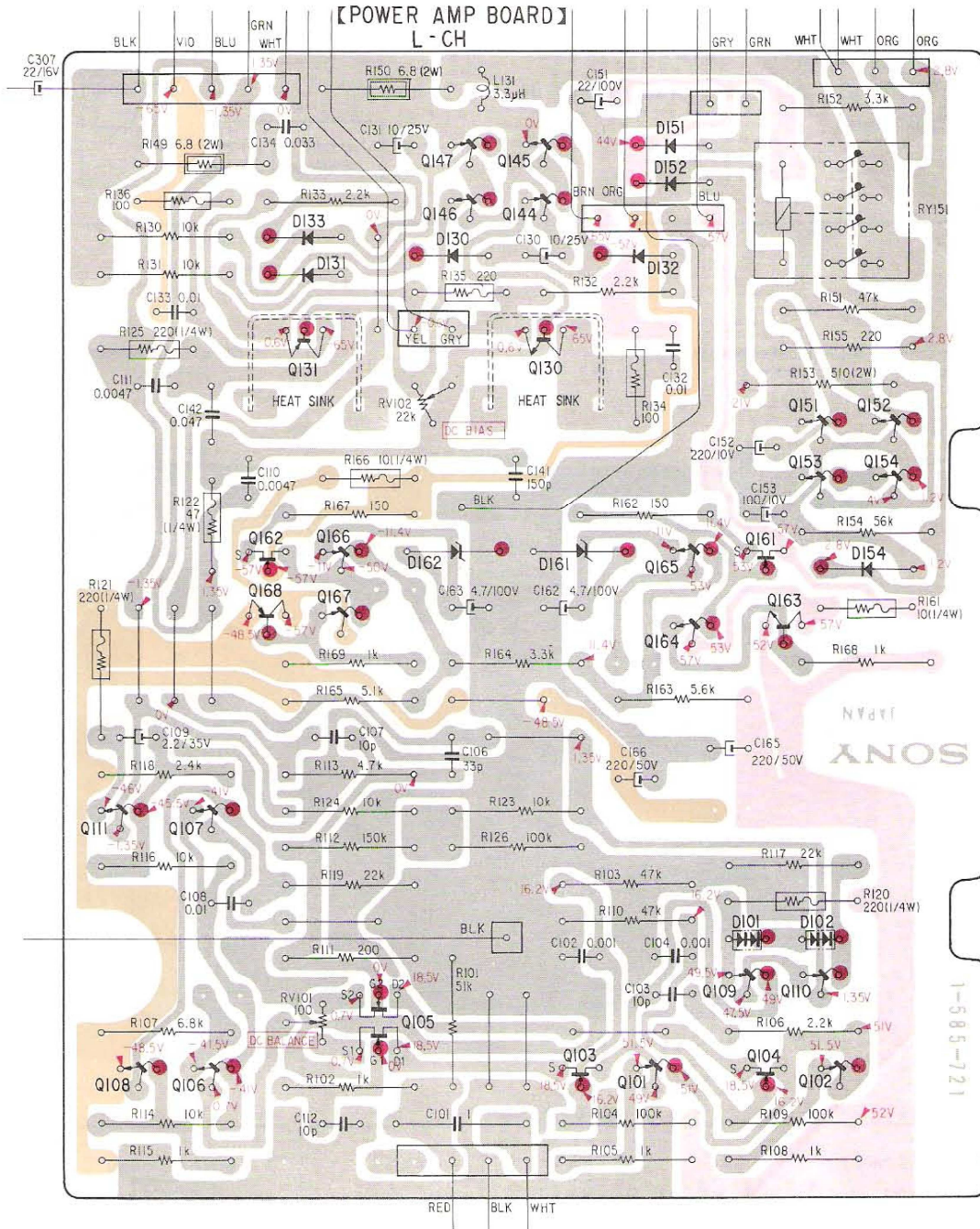

Q	III 108	107 106	162 168	131 167	166 105	147 146	145 144 130	103	101	165 164	161 109 104	151 153 110 102	152 154
D			133 131			130 162		161	132	151 152	101	102	154

- : B + pattern
- : B - pattern
- : nonflammable resistor
- : fusible resistor.

4-2. MOUNTING DIAGRAM – R-CH Power Amp Board –
 – Conductor Side –

● Replacement Semiconductors: See page 8.

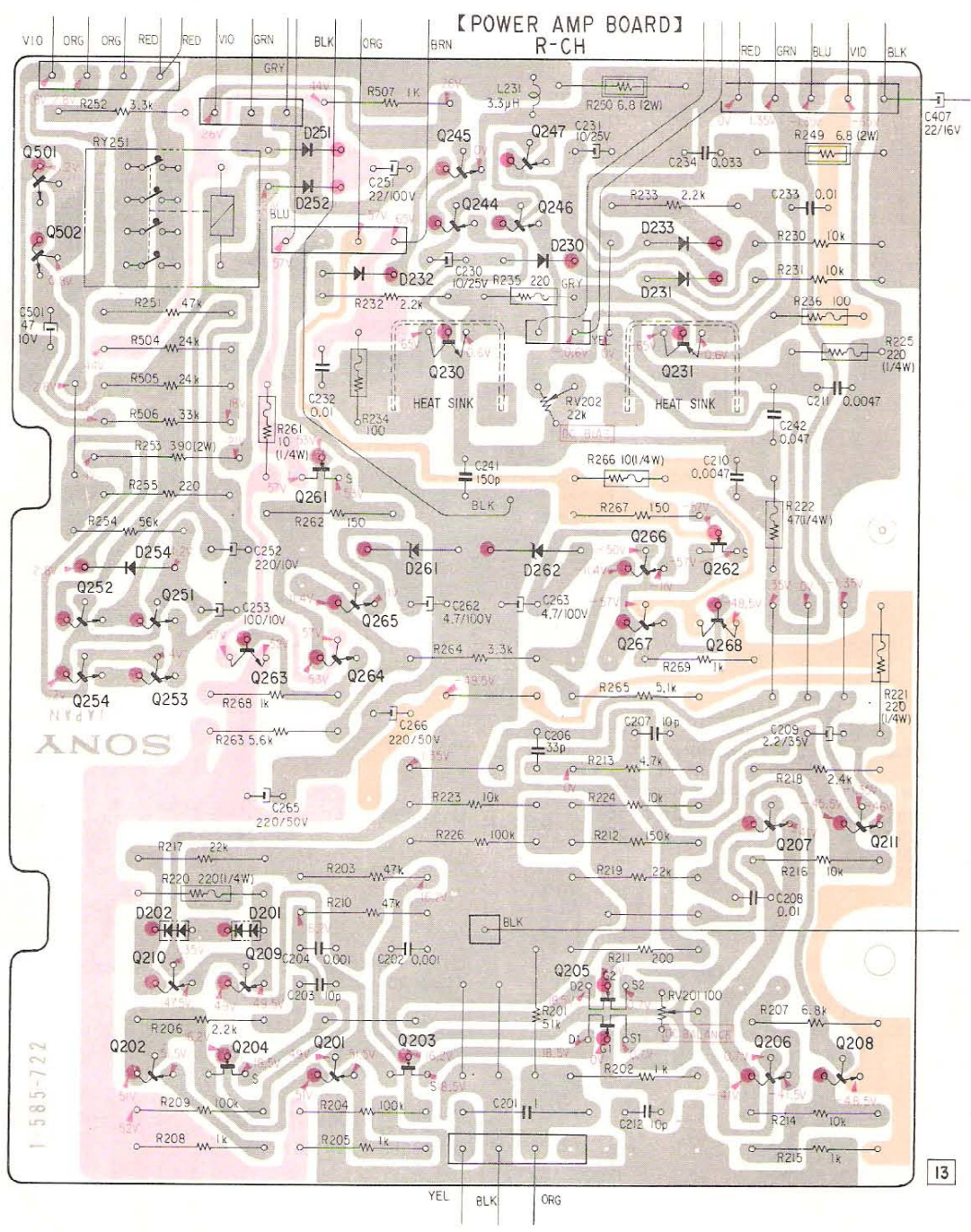

Q	501 502	252 254	251 253 210	263 209	261 264 265 203	245 244 230	247 246	266 205 267	231 268	262 206	207 208
D		254 202		201	251 252	232 261		230 262	233 231		

- : B+pattern
- : B - pattern
- : nonflammable resistor
- : fusible resistor.

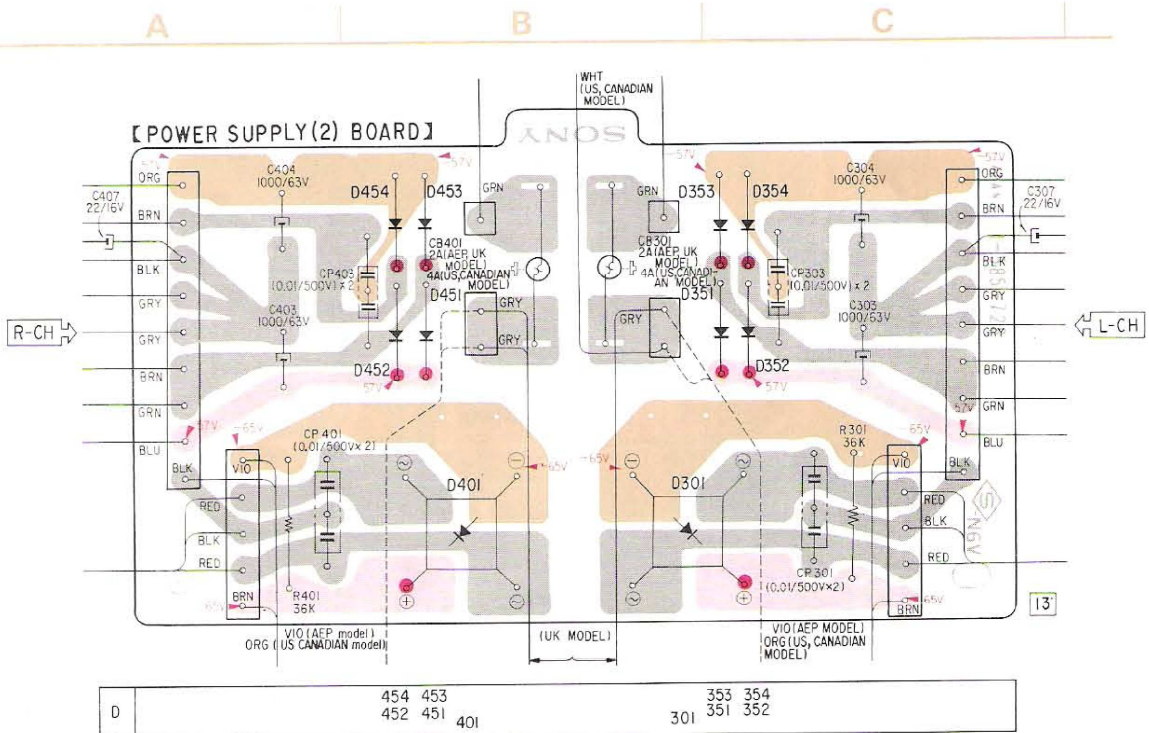

● Replacement Semiconductors

For replacement, use semiconductors except in ().

Q101, 102, 144
147, 166, 167
201, 202, 244
247, 266, 267 } : 2SA678



Q106-108 : 2SC926A
206-208

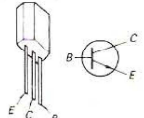

Q131, 231 : 2SA835

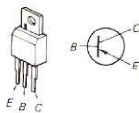

Q141-143 : 2SJ18
241-243

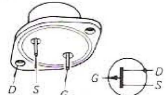

D130-133 : 1S1555
230-233

D151, 152
251, 252
351-354
451-454 } : 10E2



D154, 254 : 1T22AM (1T22A)



Q103, 104 : 2SK30A
203, 204



Q145, 146, 151-154 : 2SC1364
245, 246, 251-254
164, 165, 264, 265
501, 502

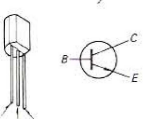

Q132-134 : 2SK60
232-234

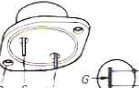

Q161, 162 : 2SK42-2
261, 262

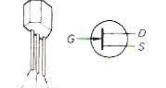

D161, 162 : EQB01-112
261, 262



Q105, 205 : 2SK97

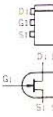

(2SC634A)

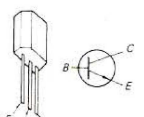

Q135-137 : 2SC1173
235-237 : 2SC1173
Q163, 263 : 2SC1061

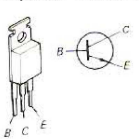

D101, 102 : MV12N
201, 202

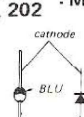

D301, 401 : S5VB20

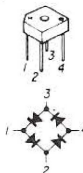

Q109, 209 : 2SA639S



Q111, 130 : 2SC 1962
211, 230

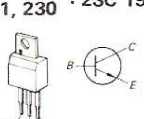

Q138-140 : 2SA473
238-240 : 2SA473
Q168, 268 : 2SA671

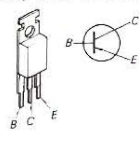

D103, 203 : SV04S (SV04F)

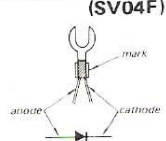

Q110, 210 : 2SA896



4-4. MOUNTING DIAGRAM — L-CH Power Amp Board — — Component Side —

Note:

- : B + pattern
 - : B - pattern
 - → : signal path
 - ▲ : nonflammable resistor
 - F : fusible resistor.
- Voltages are dc with respect to ground unless otherwise noted.
 - Readings are taken under no signal conditions with a VOM (20k Ω /V).
 - () : voltage variations according to the rank of V-FET.

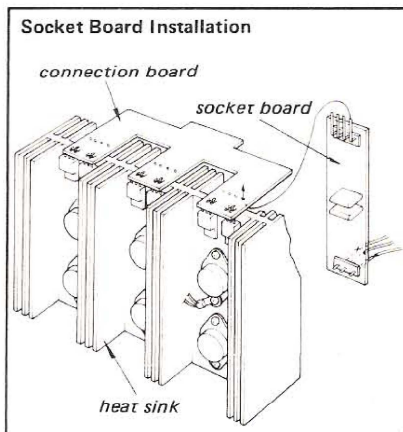

power amp (R-CH)

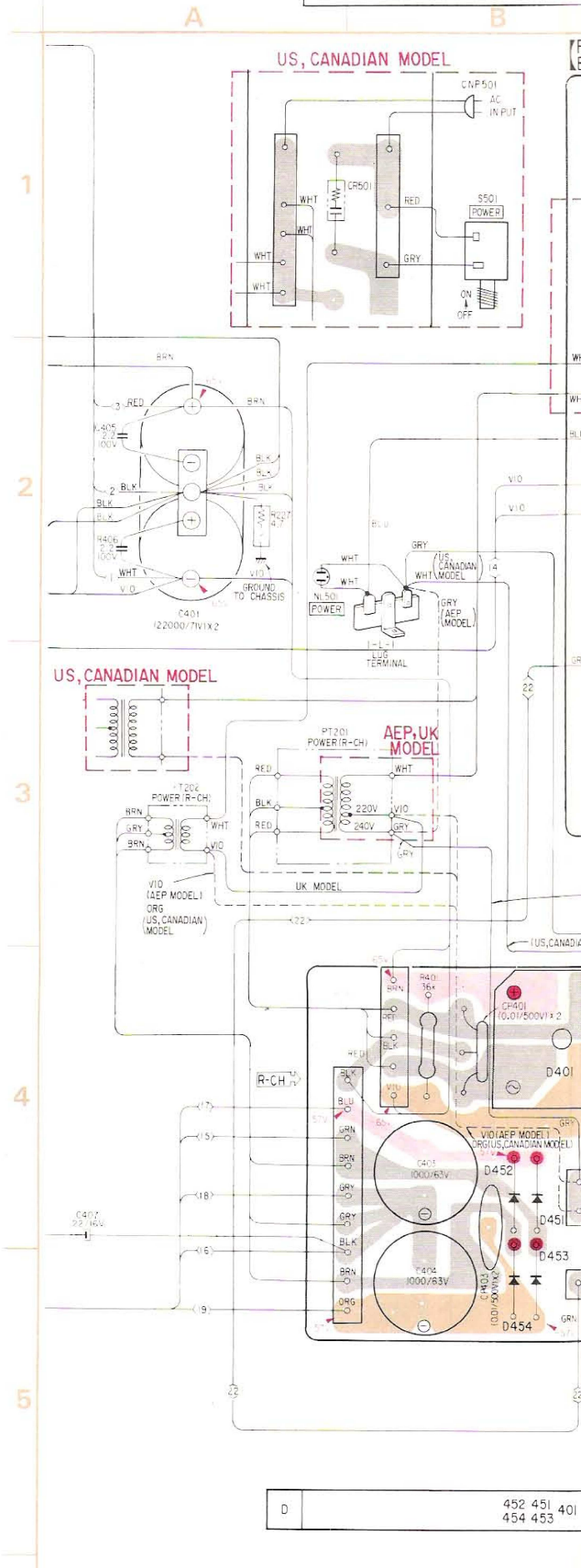

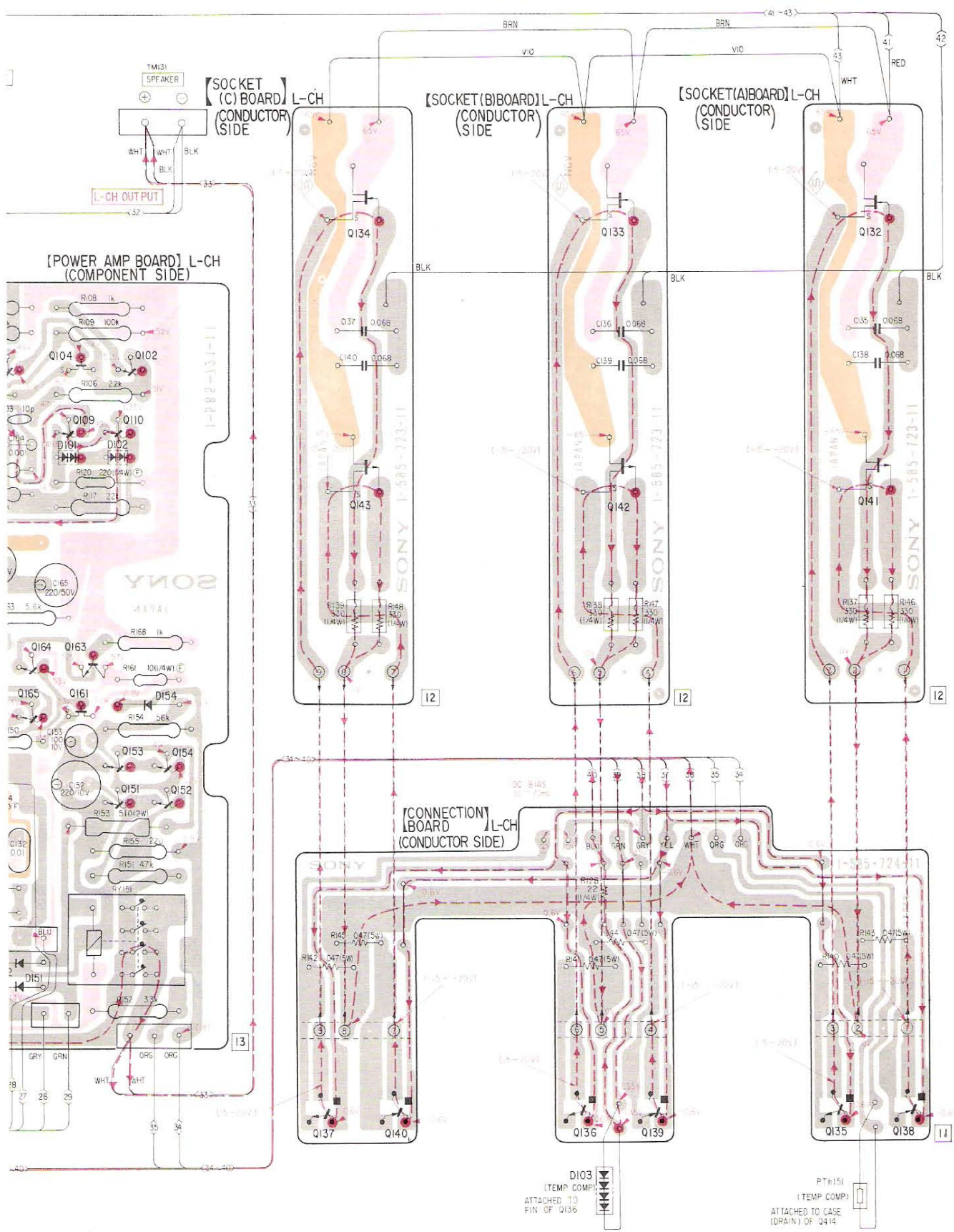

164	109	104	163	102	154	134	133	132	Q
165	161	110	151	152	137	143	140	135	141
152	101	102	154						
151							103		D

4-5. MOUNTING DIAGRAM — R-CH Power Amp Board —

— Component Side —

● Replacement Semiconductors: See page 8.

- : B+ pattern
- : B-pattern
- : signal path
- : nonflammable resistor.
- : fusible resistor.
- Voltages are dc with respect to ground unless otherwise noted.
- Readings are taken under no signal conditions with a VOM (20k Ω /V).
- () : voltage variations according to the rank of V-FET.

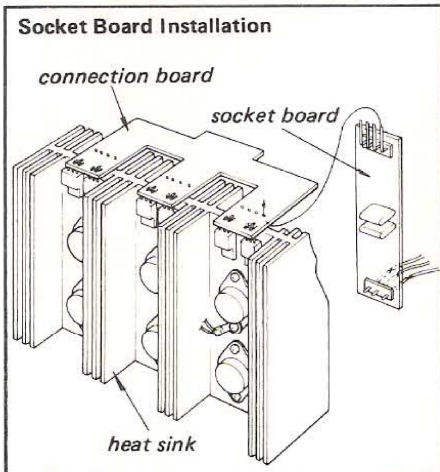
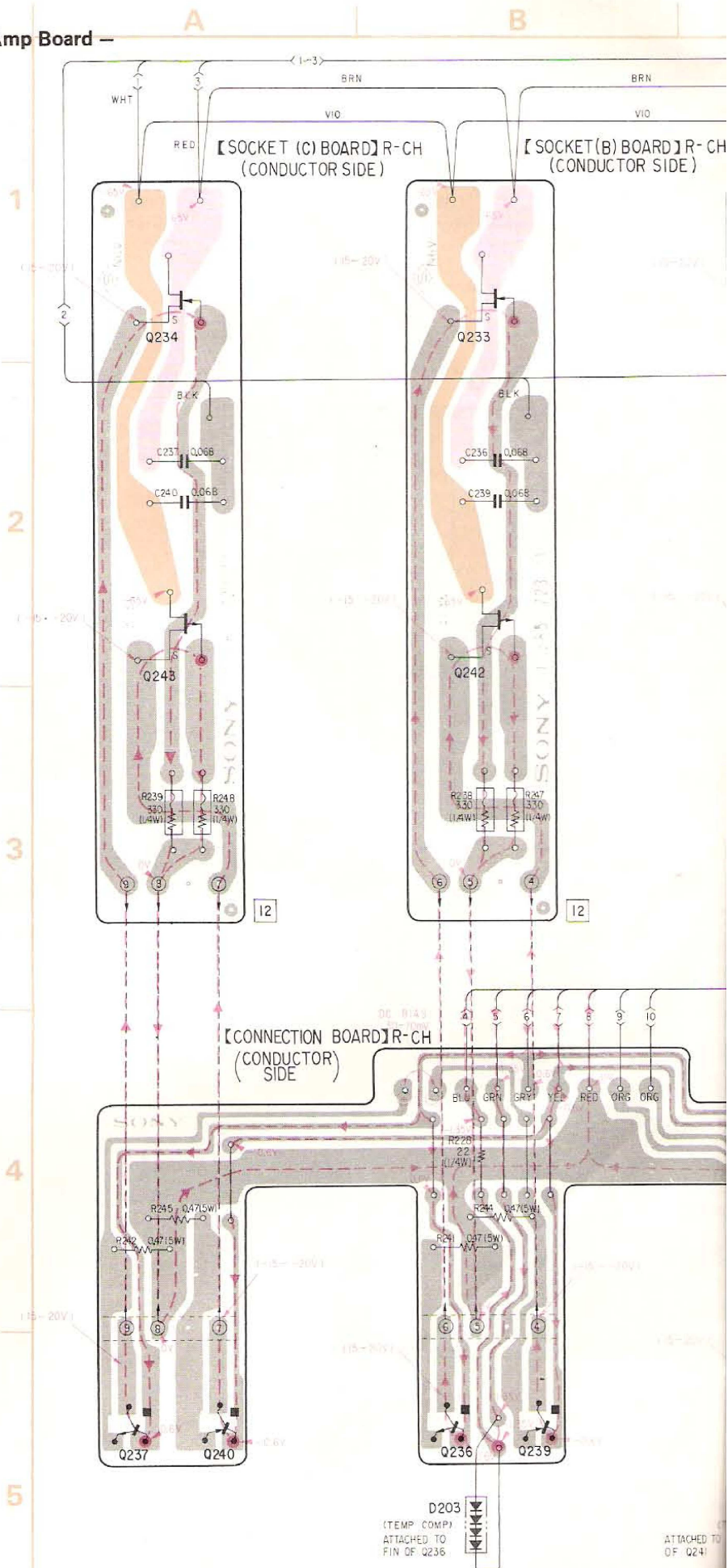

Q	237	234	240	233	242	239
D		243		236		203

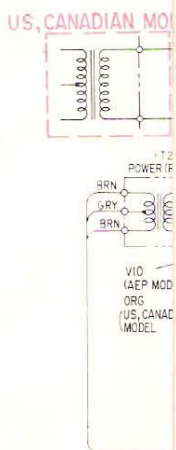
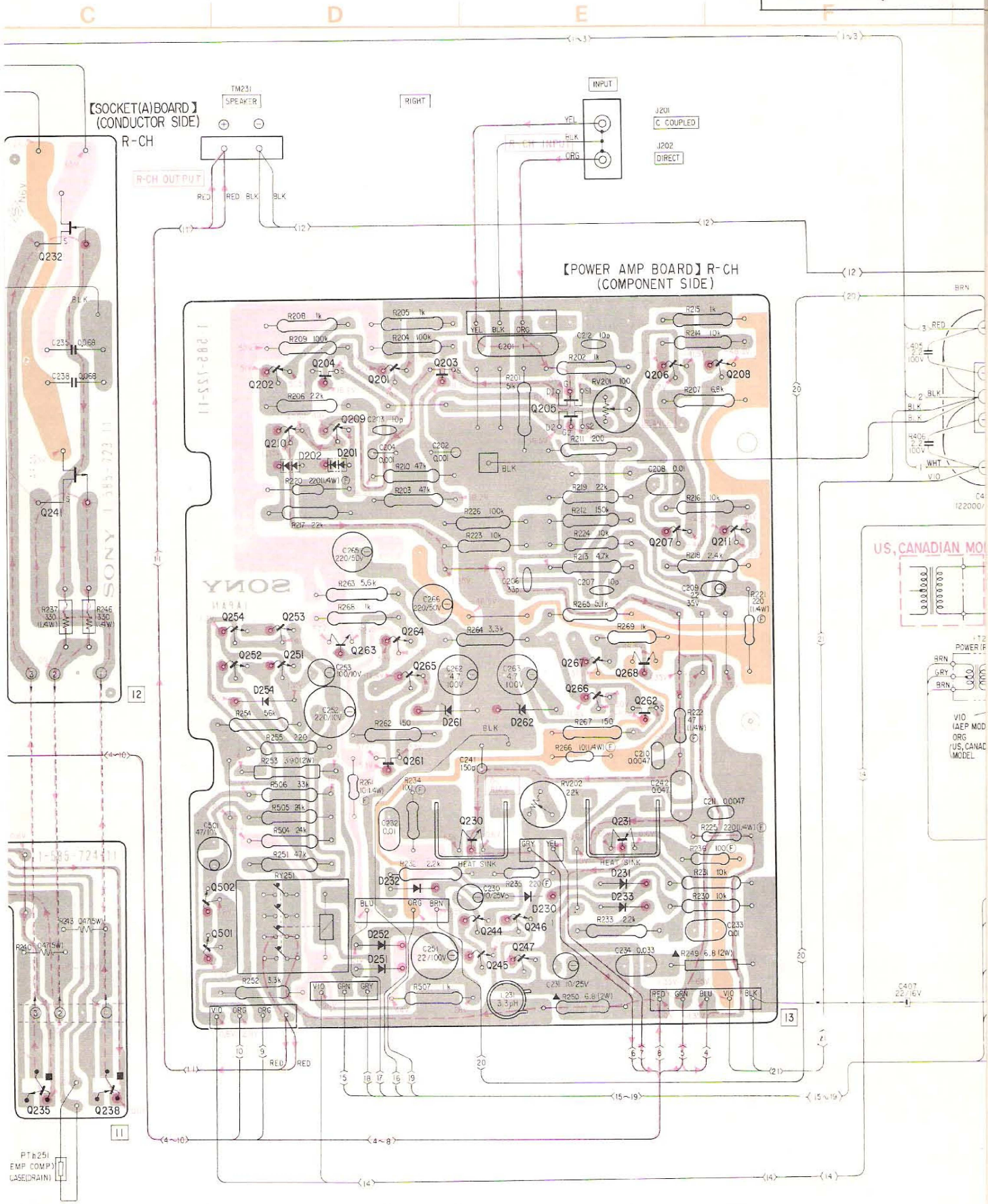

232	254	210	209	201	265	203	230	246	205	267	231	268	206	208	Q
235	241	238	502	252	202	204	244	247	266	266	266	262	207	211	
			501	251	251	263	245	247				231			
				254	202	201	252	262			233				D
				251	251	252	251	230							

Note: The components identified by shading and Δ mark are critical for safety. Replace only with part number specified.

Note: Les composants identifiés par une hachure et un Δ sont critiques pour la sécurité. Remplacer par une pièce portant le numéro spécifié.

4-6. SCHEMATIC DIAGRAM

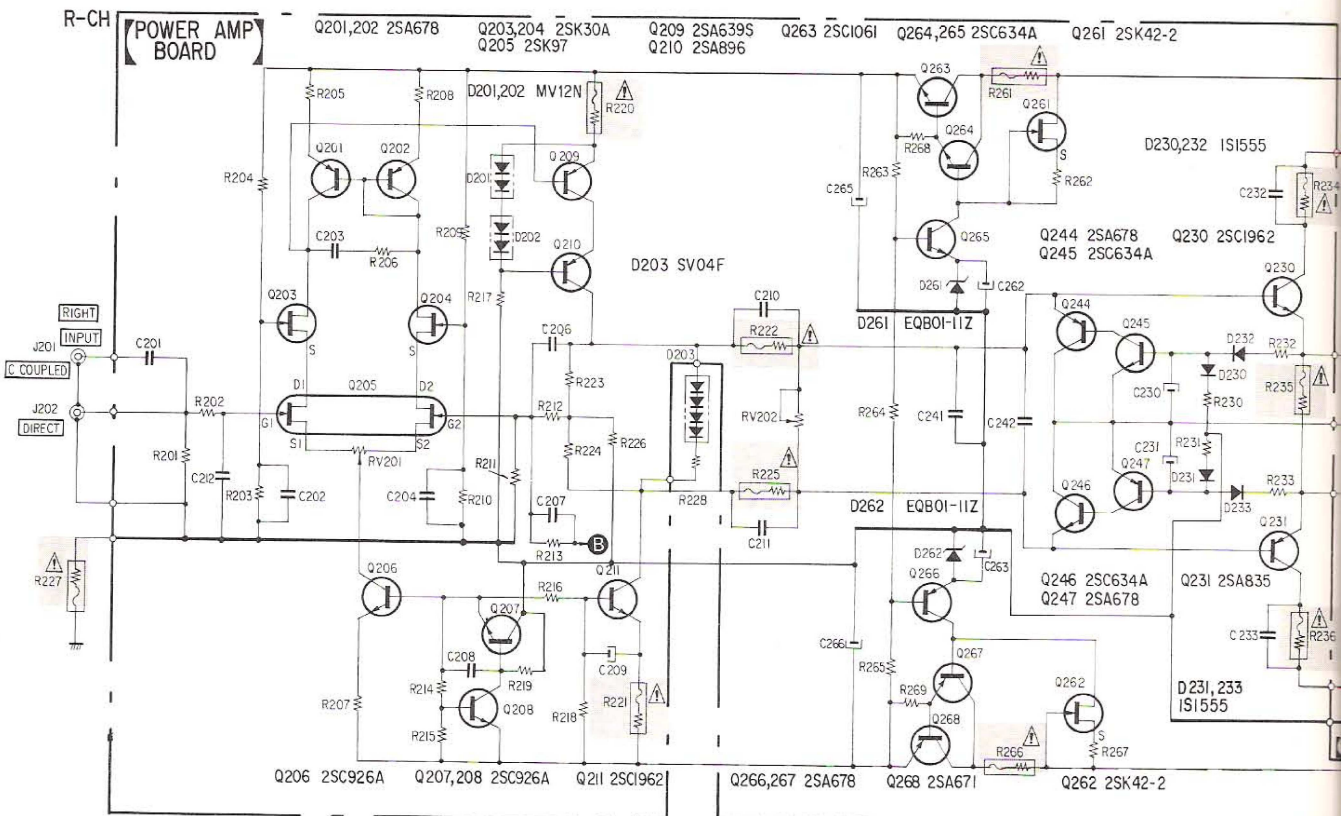
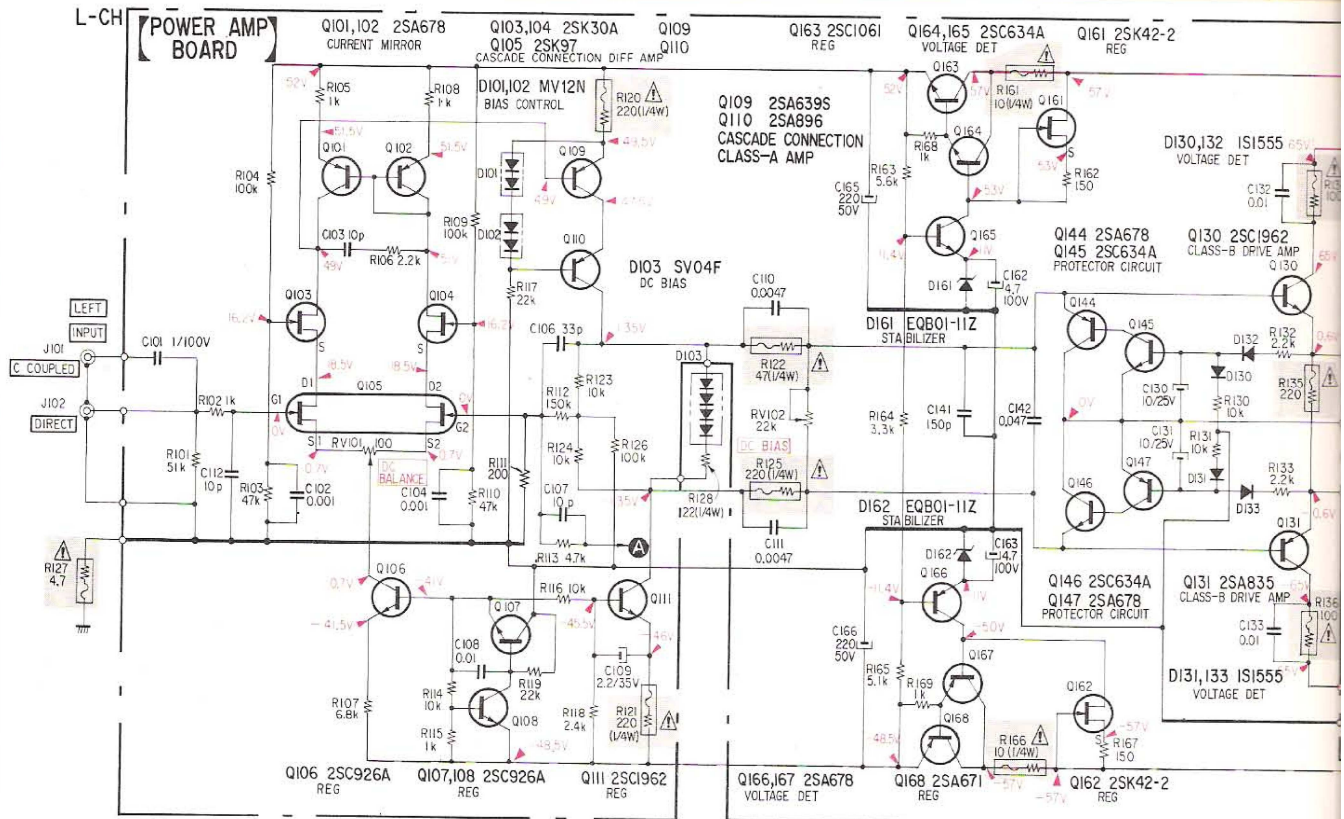

PUK MODEL

[DARD]

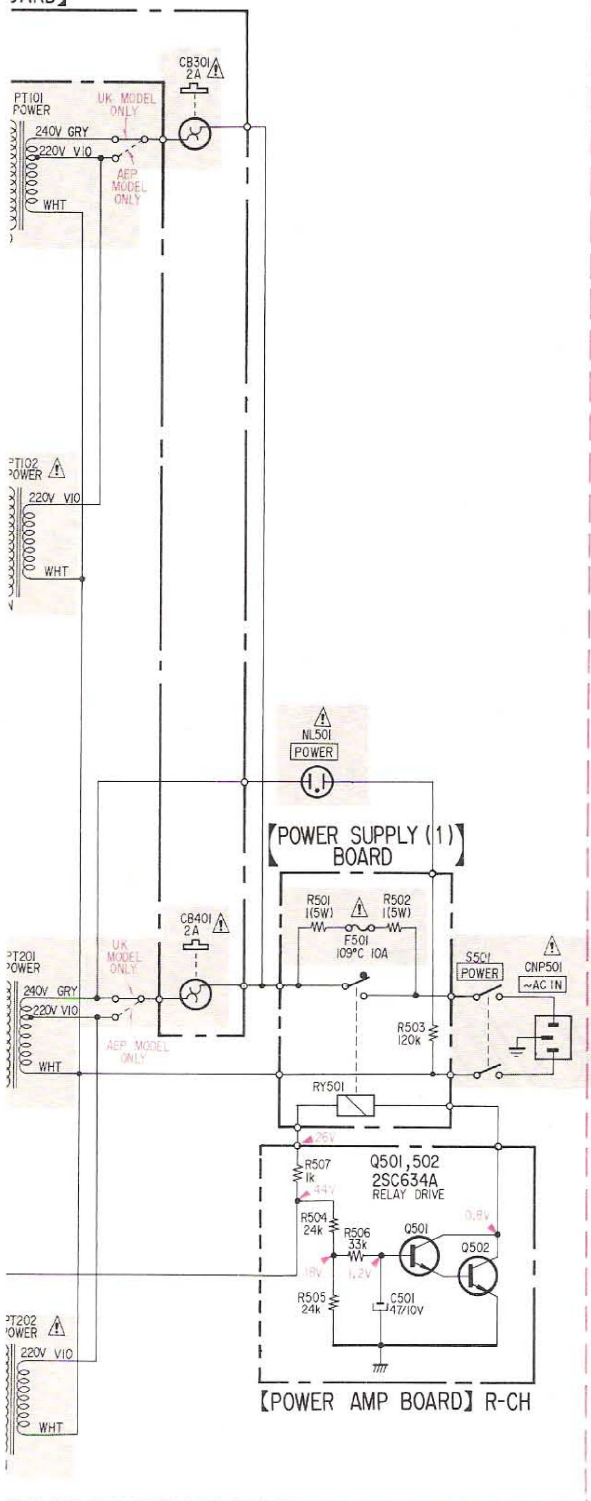

US, CANADIAN MODEL

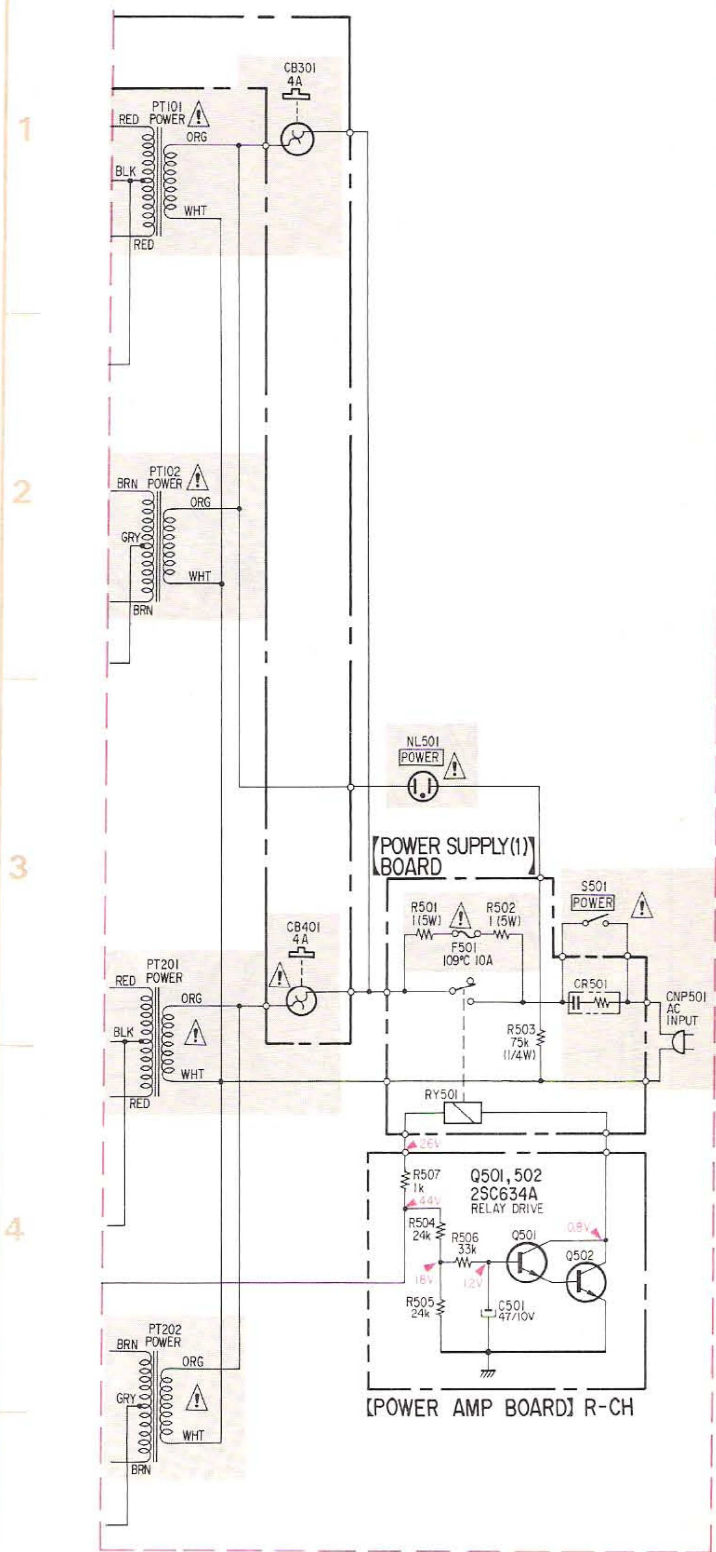

- All capacitors are in μF unless otherwise noted. $\text{pF} = \mu\text{F}$
- All resistors are in ohms $\frac{1}{4}\text{W}$ unless otherwise noted. $\text{k}\Omega = 1000\Omega$, $\text{M}\Omega = 1000\text{k}\Omega$
- : nonflammable resistor.
- : fusible resistor.
- : B+ bus.
- : B- bus.
- : panel designation.

- : adjustment for repair.
- Voltages are dc with respect to ground unless otherwise noted.
- Readings are taken under no signal conditions with a VOM (20k Ω /V).
- () : voltage variations according to the rank of V-FET.
- Switch

Ref. No.	Switch	Position
S501	POWER	OFF

SECTION 5
EXPLODED VIEWS

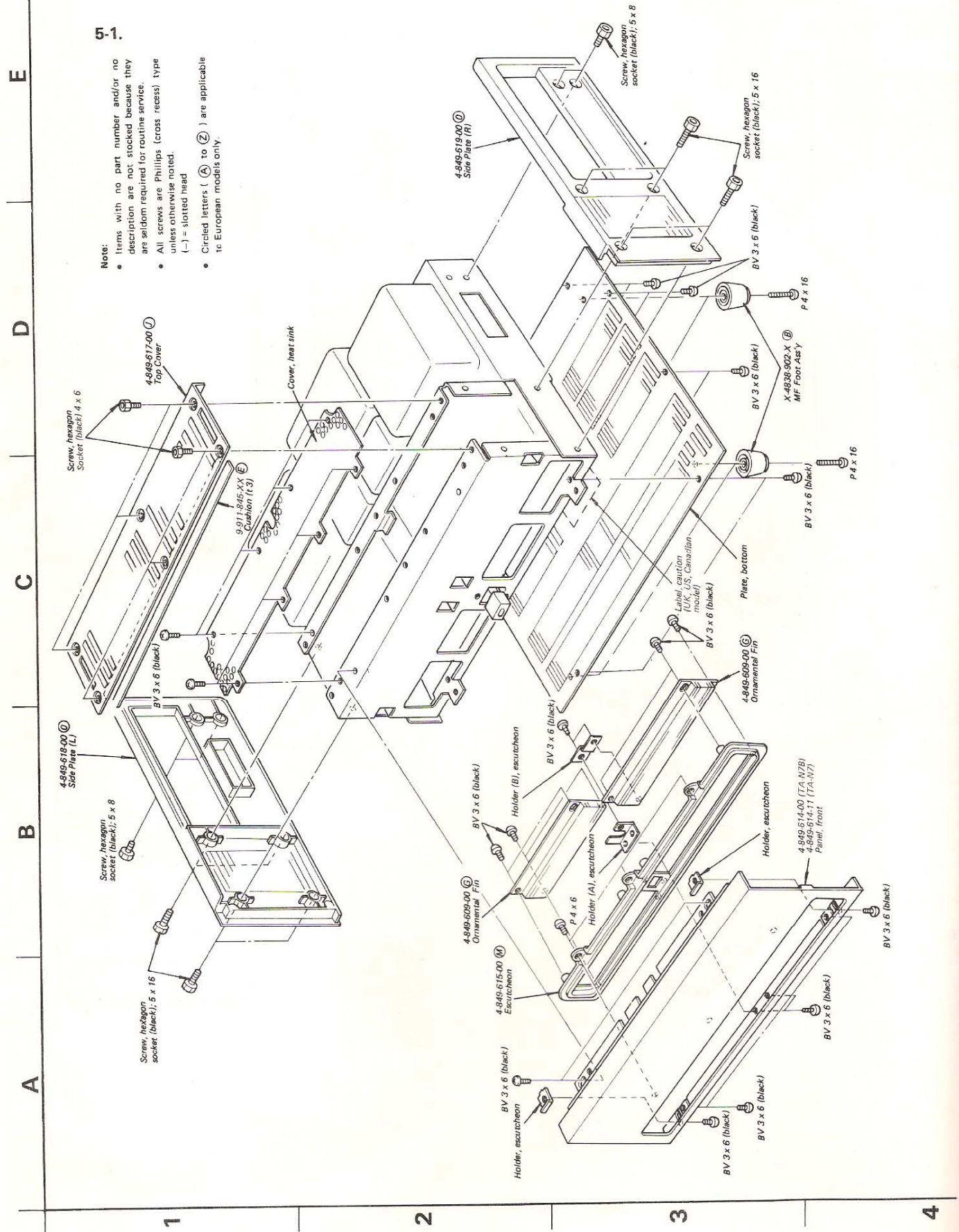

5-1.

- Note:
- Items with no part number and/or no description are not stocked because they are seldom required for routine service.
 - All screws are Phillips (cross recess) type unless otherwise noted.
 - (-) = slotted head
 - Circled letters (A) to (Z) are applicable to European models only.

5-2.

A B C D E

- Note:
- Items with no part number and/or no description are not stocked because they are seldom required for routine service.
 - All screws are Phillips (cross recess) type unless otherwise noted.
 - (-) = slotted head
 - Circled letters (A) to (Z) are applicable to European models only.

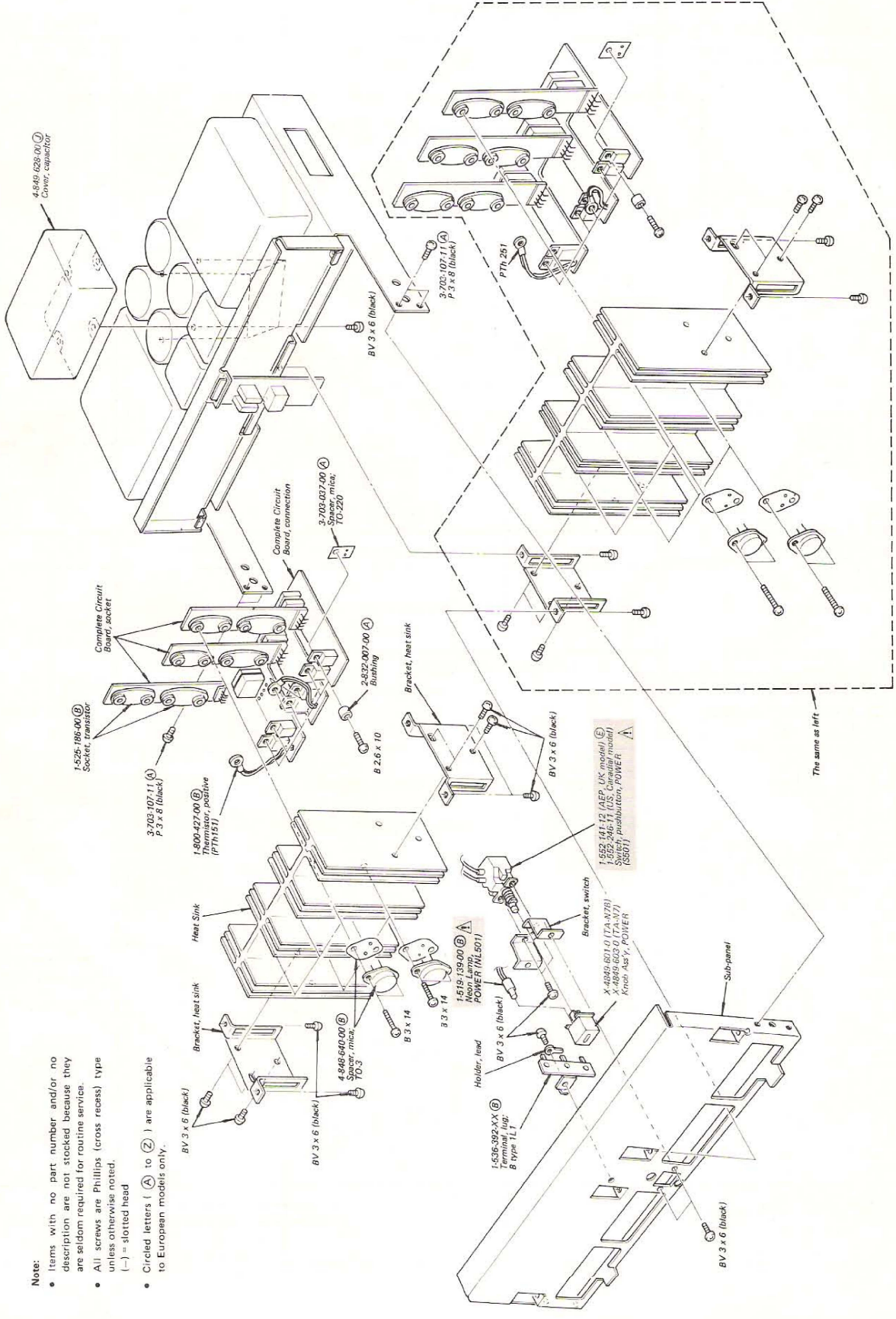

Note: Les composants identifiés par un trame et une marque **A** sont critiques pour la sécurité. Ne les remplacer que par une pièce portant le numéro spécifié.

Note: The components identified by shading and **A** mark are critical for safety. Replace only with part number specified.

1

2

3

4

**SECTION 6
ELECTRICAL PARTS LIST**

• Circled letters (A to Z) are applicable to European models only.

Ref. No. Part No. Description

Ref. No. Part No. Description

SEMICONDUCTORS

Transistors

Q101, 201 Q102, 202	8-727-788-00	C	2SA678
Q103, 203 Q104, 204			
Q105, 205	8-729-203-04	B	2SK30A
Q106-108 Q206-208	8-720-950-03	D	2SC926A
Q109, 209 Q110, 210			
Q111, 211 Q130, 230	8-765-170-01	E	2SC1962
Q131, 231 Q132-134 Q232-234			
Q135-137 Q235-237	8-729-217-33	C	2SC1173
Q138-140 Q238-240			
Q141-143 Q241-243	8-762-455-00	K	2SJ18
Q144, 244 ⇒ Q145, 245 ⇒ Q146, 246			
Q147, 247 ⇒ Q151-154 ⇒ Q251-254	8-727-788-00	C	2SA678
Q161, 261 Q162, 262			
Q163, 263 ⇒ Q164, 264 ⇒ Q165, 265	8-729-316-12	D	2SC1061
Q166, 266 Q167, 267			
Q168, 268 ⇒ Q501, 502	8-727-788-00	C	2SA678
	8-729-317-12	E	2SA671
	8-729-663-47	B	2SC1364

Diodes

D101, 201 D102, 202	8-719-912-00	B	MV12N
⇒ D103, 203			
D130-133 D230-233	8-719-300-11	C	SV04S
D151, 251			
D152, 252	8-719-815-55	B	1S1555
⇒ D154, 254	8-719-200-02	B	10E2
D161, 261 D162, 262			
D301, 401 D351-354 D451-454	8-719-505-20	F	S5VB20
	8-719-200-02	B	10E2

Thermistor

PTH 151 PTH 251	1-800-427-00	B	positive

CAPACITORS

All capacitors are in μF and ceramic unless otherwise noted.
50WV or less are not indicated except for electrolytics. pF = $\mu\mu\text{F}$, elect = electrolytic

C101, 201 C102, 202	1-130-083-11	C	1	100V	polyethylene
C103, 203 C104, 204					
C106, 206 C107, 207	1-103-775-11	A	0.001		polystyrol
C108, 208 C109, 209					
C110, 210 C111, 211	1-102-947-11	A	10p		polystyrol
C112, 212					
C130, 230 C131, 231	1-102-963-11	A	33p		
C132, 232 C133, 233					
	1-102-947-11	A	10p		
	1-108-239-12	A	0.01		mylar
	1-131-217-11	B	2.2	35V	tantalum
	1-108-234-12	A	0.0047		mylar
	1-102-947-11	A	10p		
	1-123-187-11	A	10	25V	elect
	1-108-239-12	A	0.01		mylar

• ⇒ : Due to standardization, interchangeable replacements may be substituted for parts specified in the diagrams.

Note: The components identified by shading and Δ mark are critical for safety. Replace only with part number specified.

Note: Les composants identifiés par un tramé et une marque Δ sont critiques pour la sécurité. Ne les remplacer que par une pièce portant le numéro spécifié.

• Circled letters (A to Z) are applicable to European models only.

Ref. No.	Part No.	Description
C134, 234	1-108-244-12 (A)	0.033 mylar
C135-140 C235-240	1-108-847-12 (A)	0.068 mylar
C141, 241	1-103-755-11 (A)	150p polystyrol
C142, 242	1-108-246-12 (A)	0.047 mylar
C151, 251	1-123-081-11 (B)	22 100V elect
C152, 252	1-123-072-11 (B)	220 10V elect
C153, 253	1-123-196-11 (A)	100 10V elect
C162, 262 C163, 263	1-123-255-11 (B)	4.7 100V elect
C165, 265 C166, 266	1-121-423-11 (B)	220 50V elect
C301, 401	△1-125-151-11 (C)	22000+22000 71V elect
C303, 403 C304, 404	1-123-262-11 (E)	1000 63V elect
C305, 405 C306, 406	△1-130-084-11 (D)	2.2 100V polyethylene
C307, 407	1-121-479-11 (A)	22 16V elect
C501	1-123-195-11 (A)	47 10V elect

RESISTORS

All resistors are in ohms and 1/2W carbon unless otherwise noted.

R101, 201	1-244-914-11 (A)	51k
R102, 202	1-244-873-11 (A)	1k
R103, 203	1-244-913-11 (A)	47k
R104, 204	1-244-921-11 (A)	100k
R105, 205	1-244-873-11 (A)	1k
R106, 206	1-244-881-11 (A)	2.2k
R107, 207	1-244-893-11 (A)	6.8k
R108, 208	1-244-873-11 (A)	1k
R109, 209	1-244-921-11 (A)	100k
R110, 210	1-244-913-11 (A)	47k
R111, 211	1-244-856-11 (A)	200
R112, 212	1-244-925-11 (A)	150k
R113, 213	1-244-889-11 (A)	4.7k
R114, 214	1-244-897-11 (A)	10k
R115, 215	1-244-873-11 (A)	1k

Note: The components identified by shading and △ mark are critical for safety. Replace only with part number specified.

Ref. No.	Part No.	Description
R116, 216	1-244-897-11 (A)	10k
R117, 217	1-244-905-11 (A)	22k
R118, 218	1-244-882-11 (A)	2.4k
R119, 219	1-244-905-11 (A)	22k
R120, 220 R121, 221	△1-212-889-11 (A)	220 1/4W fusible
R122, 222 R123, 223 R124, 224	△1-212-873-11 (A)	47 1/4W fusible
R125, 225 R126, 226	△1-212-889-11 (A)	220 1/4W fusible
R127, 227 R128, 228	△1-212-950-11 (A)	4.7 1/2W fusible
R129, 229	1-244-633-11 (A)	22 1/4W
R130, 230 R131, 231	1-244-897-11 (A)	10k
R132, 232 R133, 233	1-244-881-11 (A)	2.2k
R134, 234	△1-212-982-11 (A)	100 1/2W fusible
R135, 235 R136, 236	△1-212-990-11 (A)	220 1/2W fusible
R137-139 R237-239	△1-212-982-11 (A)	100 1/2W fusible
R140-145 R240-245	△1-212-893-11 (A)	330 1/4W fusible
R146-148 R246-248	△1-217-158-11 (A)	0.47 5W metal oxide
R149, 249 R150, 250	△1-212-893-11 (A)	330 1/4W fusible
R151, 251	1-206-459-11 (A)	6.8 2W metal oxide
R152, 252	1-244-913-11 (A)	47k
R153, 253	1-244-885-11 (A)	3.3k
R154, 254 R155, 255	△1-206-657-11 (A)	510 2W metal oxide
R156, 256	1-244-915-11 (A)	56k
R157, 257	1-244-857-11 (A)	220
R161, 261 R162, 262	△1-212-857-11 (A)	10 1/4W fusible
R163, 263	1-244-853-11 (A)	150
R164, 264	1-244-891-11 (A)	5.6k
R165, 265	1-244-885-11 (A)	3.3k
R166, 266	1-244-890-11 (A)	5.1k

Note: Les composants identifiés par un tramé et une marque △ sont critiques pour la sécurité. Ne les remplacer que par une pièce portant le numéro spécifié.

TA-N7/N7B

Ref. No.	Part No.	Description
R166, 266	1-212-857-11 (A)	10 ¼W fusible
R167, 267	1-244-853-11 (A)	150
R168, 268 R169, 269	1-244-873-11 (A)	1k
R301, 401	1-244-910-11 (A)	36k
R501, 502	1-217-160-11 (B)	1 5W metal oxide
R503	1-244-718-11	75k ¼W (US, Canadian model)
	1-244-925-11 (A)	120k (AEP, UK model)
R504, 505	1-244-906-11 (A)	24k
R506	1-244-909-11 (A)	33k
R507	1-244-873-11 (A)	1k
RV101, 201	1-224-247-XX (C)	100 adjustable, DC balance
RV102, 202	1-224-253-XX (C)	22k adjustable, DC bias

SWITCH

S501	1-552-141-12 (E)	Pushbutton, POWER (AEP, UK model)
	1-552-246-11	Pushbutton, POWER (US, Canadian model)

MISCELLANEOUS

CB301, 401	1-532-523-11	Circuit Breaker, 4A (US, Canadian model)
	1-532-531-11 (C)	Circuit Breaker, 2A (AEP, UK model)
CNP501	1-509-546-00 (D)	Socket, 3p AC IN (AEP, UK model)
	1-551-421-11	Cord, power (US, Canadian model)
CP301, 303	1-102-355-11 (B)	Encapsulated Component
CP401, 403	1-231-326-11	Encapsulated Component (US model)
	1-231-341-00	Encapsulated Component (Canadian model)
F501	1-532-496-00 (C)	Fuse, 109°C, 10A
J101, 201	1-507-378-21 (B)	Jack, 2p; C-COUPLED, DIRECT
J102, 202		
L131, 231	1-420-879-00 (B)	Coil, 3.3µH
NL501	1-519-139-00 (B)	Neon Lamp, power
PT101, 201	1-442-971-00	Transformer, power (US, Canadian model)
	1-442-973-00 (V)	Transformer, power (AEP, UK model)
PT102, 202	1-442-970-00	Transformer, power (US, Canadian model)
	1-442-972-00 (O)	Transformer, power (AEP, UK model)
RY151, 251	1-515-293-00 (H)	Relay
RY501	1-515-278-00 (F)	Relay
TM131	1-535-195-21 (F)	Terminal Strip 2p; LEFT SPEAKER
TM231	1-535-195-31 (E)	Terminal Strip 2p; RIGHT SPEAKER
	1-525-186-00 (B)	Socket, transistor
	1-536-392-XX (B)	Terminal, lug

Note: The components identified by shading and  mark are critical for safety. Replace only with part number specified.

• Circled letters ( to ) are applicable to European models only.

ACCESSORIES & PACKING MATERIALS

Part No.	Description
1-534-819-12 (G)	Cord, power (UK model)
3-701-622-00 (A)	Bag, plastic (UK model)
3-701-630-00 (A)	Bag, plastic; printed matters
3-770-058-21	Manual, instruction (US model)
3-770-058-21,	Manual, instruction (Canadian model)
3-794-245-31	
3-770-441-11 (H)	Manual, instruction (AEP, UK model)
4-848-648-00 (B)	Bag, protection; set
4-849-622-00 (C)	Cushion (A)
4-849-623-00 (C)	Cushion (B)
4-849-637-00 (F)	Carton (TA-N7)
4-849-638-00 (C)	Spacer
4-849-639-00 (C)	Cushion, lower
4-849-643-00 (G)	Carton (TA-N7B)

Note: Les composants identifiés par un tramé et une marque  sont critiques pour la sécurité. Ne les remplacer que par une pièce portant le numéro spécifié.