

# Service Manual

## Tape recorders 3300X / 3400X



# TANDBERG

## GENERAL INFORMATION

**Note:** All paragraphs in this manual are valid for both series 3300X and 3400X except for those who are particularly marked for a special version, example 3.8 Output Amplifiers (3400X).

- Use only Low Noise High Output Tape for recording. A good head-to-tape contact is essential for obtaining satisfactory frequency response and signal/noise ratio. In order to obtain the best possible results with new tapes, these should be run through approximately 5 times in drive mode in order to polish the surface of the tape. Always check that heads and tape guides are clean. For cleaning purposes, use a special liquid such as Tandberg Professional Tape Head Cleaner or pure alcohol or benzine.
- In order to make magnetized parts of the tape visible, dip the tape in "Magna-See", a mixture of iron oxide powder and alcohol. Iron oxide powder can be obtained from our service department.
- Heads, tape guides and capstan must be degaussed both before and after adjustment of heads and tape guides. Move the degausser slowly past the head gaps at a very short distance, but without touching the heads. Then hold the degausser close to the capstan for a few seconds. Start the tape recorder and hold the degausser just above the flywheel.

**Note:** Do not switch off the degausser until it is at a distance of about 1 meter (3 feet) from the tape recorder.

- Perform the adjustments in the same sequence as explained, because some of the adjustment procedures assume that the previous adjustments have already been performed. If not otherwise specified, make all adjustments at 7<sup>1</sup>/<sub>2</sub> ips.
- For checking and adjustments of heads and tape guides, only the head covers need to be removed. For electrical adjustments also the cabinet and the bottom cover must be detached. Removal of the top plate will usually only be necessary for checking and adjustments of clutches and other parts in the drive mechanism.
- **Removal of Cabinet and Bottom Cover**  
The cabinet is attached with 6 screws, 2 on each side and 2 on the front. When these are unscrewed, pull the cabinet walls off the chassis. Removal of the cabinet walls is unaffected by the top and bottom covers. The bottom cover is attached with 6 screws which must be unscrewed before removal.

- **Removal of Top Plates**

Remove the head covers by pressing the spring-loaded buttons and lifting the covers off. Then remove the speed selector knob, knobs for input level and output level, start/stop knob, sound on sound knob, bass/treble, and the operating lever knob. The knobs are retained by springs and can be pulled straight off. Unscrew the 10 screws shown in figure.

- For ordering of parts see separate "Illustrated Parts List".

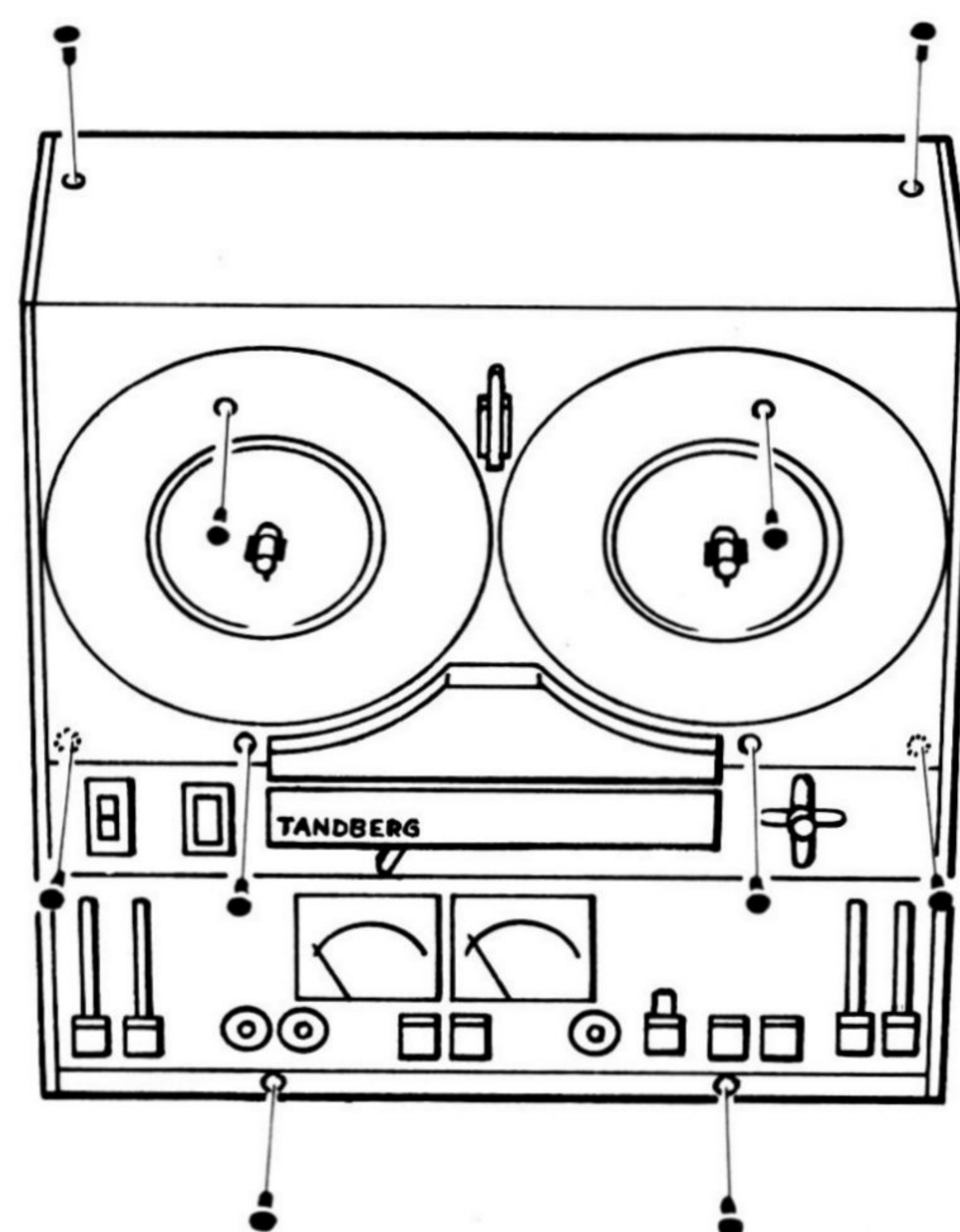

Fig. 1. Top plate screws.

**Note:** In any communication pertaining to the equipment, please specify type and serial number.

# CONTENTS

Paragraph	Page	Paragraph	Page
1.0 Technical specifications .....	2	3.4.1 Playback head .....	12
2.0 Mechanical adjustments .....	4	3.4.2 Record head .....	12
2.1 Clutches .....	4	3.4.3 Bias head .....	12
2.1.1 Checking of clutch torque .....	4	3.4.4 Erase head .....	12
2.1.2 Take-up turntable .....	4	3.5 Models 3321X and 3421X—two track .....	12
2.1.3 Supply turntable .....	5	3.6 Track control .....	13
2.2 Brakes .....	5	3.6.1 Models 3341X and 3441X .....	13
2.3 Tape path .....	6	3.6.2 Models 3321X and 3421X .....	13
2.3.1 Visual check .....	6	3.7 Adjustment and control of the amplifiers .....	14
2.3.2 Capstan adjustment .....	6	3.7.1 Playback level adjustment .....	14
2.3.3 Pinch roller adjustment .....	7	3.7.2 Adjustment of bias head .....	14
2.3.4 Heads .....	7	3.7.3 Record level adjustment .....	14
2.3.5 Pressure pad .....	8	3.7.4 Record/playback curves .....	14
2.3.6 Inertia idling roller .....	8	3.7.5 Distortion .....	14
2.3.7 Checking and readjustment of tape guide posts .....	9	3.7.6 Control of playback amplifier using test tape .....	14
2.4 Lubrication .....	9	3.7.7 Tape speed control .....	14
2.4.1 Motor .....	9	3.7.8 Record/playback curves .....	15
2.4.2 Self lubricating bearings .....	9	3.7.9 Readjustment of record/playback level ..	15
1.0 Electrical checks and adjustments .....	10	3.7.10 Distortion .....	15
3.1 Erase and bias circuits .....	10	3.7.11 Control of playback and record amplifiers .....	15
3.1.1 Oscillator frequency .....	10	3.8 Output amplifiers (3400X) .....	17
3.1.2 Checking of erase voltage .....	10	3.8.1 Quiescent current and symmetrical clipping (3400X) .....	17
3.1.3 Bias current .....	10	3.8.2 Checking of distortion (3400X) .....	17
3.2 Head alignment with Tandberg test tapes, models 3341X and 3441X—four track .....	10	3.9 Tone controls (3400X) .....	17
3.2.2 Record head .....	10	4.0 Modifications .....	18
3.2.3 Bias head .....	11	4.1 Modification for different line voltage and frequency .....	18
3.2.4 Erase head .....	11	4.2 Modification from four-track to two-track version .....	18
3.2.5 Alignment of hum shield for playback head .....	12	4.3 Modifications introduced during production of series 3300X .....	18
3.3 Head alignment on models 3321X and 3421X—two track .....	12	5.0 Circuit diagrams and printed wiring boards .....	20
3.4 Head alignment without Tandberg test tapes, models 3341X and 3441X—four track .....	12	5.1 Series 3300X .....	20
		5.2 Series 3400X .....	22

# 1.0 TECHNICAL SPECIFICATIONS

**Note:** The specifications are common for series 3300X and 3400X unless otherwise specified.  
The specifications given are guaranteed for all units.

<b>Mains voltage:</b>		240/230/115 V, 50 or 60 Hz. Can be rewired for any of these voltages. See paragraph 4.1 for line voltage and frequency modifications.
<b>Power consumption:</b>	(3300X) 45 W. (3400X) 130 W.	
<b>Motor:</b>		2-pole shadowpole.
<b>Tape speeds:</b>		7 <sup>1</sup> / <sub>2</sub> , 3 <sup>3</sup> / <sub>4</sub> , and 1 <sup>7</sup> / <sub>8</sub> ips.
<b>Speed tolerance:</b>		± 1 %.
<b>Tape:</b>		Maximum reel diameter, 7". Use Low Noise High Output Tape for recording. <b>Note:</b> If ordinary Low Noise Tape is used, observe that the meter deflection does not exceed - 2.5 dB mark to meet the 3 % distortion claim.
<b>Forward and reverse winding:</b>		1200 ft. of tape, 7" reel: 1 min. 45 s. 1800 ft. of tape, 7" reel: 2 min. 10 s.
<b>Heads:</b>		Erase head, record head, playback head, and bias head (Tandberg Cross-field).
<b>Record level meters:</b>		Moving coil peak reading meters. Deflection up to 0 dB corresponds to maximum 3 % tape distortion. Rise time: Approximately 40 ms.
<b>Inputs:</b>	MIC	Microphone inputs (DIN-sockets or telephone jacks), unbalanced for dynamic microphone with impedance 200/700 ohms. Sensitivity: 130 μV. Maximum input level at 400 Hz: 250 mV.
	RADIO	Radio inputs (pins 1 and 4 on DIN-socket). Impedance: 50 kohms. Sensitivity: 5 mV. Maximum input level at 400 Hz: 10 V.
	LINE (3300X)	Line inputs (phono sockets). Impedance: 1 Mohm. Sensitivity: 100 mV. Maximum input level: 30 V.
	PHONO (3400X)	Phono inputs for magnetic pick-up (DIN-socket). Sensitivity with 33 kohms load at 1000 Hz: 1 mV. Maximum input voltage: 2 V.
<b>Outputs:</b>	RADIO	Radio outputs (pins 3 and 5 on DIN-socket). Minimum load impedance: 100 ohms. Output level: A tape recorded with a 400 Hz signal to 0 dB deflection on the meter will give 1.0 V when played back.

LINE	(3300X)	Line outputs (phono sockets). Minimum load impedance: 100 ohms. Output level: A tape recorded with a 400 Hz signal to 0 dB meter reading will give 1.0 V when played back.															
HEADPHONES		Headphone outputs (stereo telephone jack). Minimum load impedance: 100 ohms. Output level: A tape recorded with a 400 Hz signal to 0 dB reading on the meter will give 1.0 V when played back.															
EXT. SPEAKER	(3400X)	External speaker outputs (DIN-sockets). Load impedance: 4–8 ohms.															
<b>Output power:</b>	(3400X)	15 W in 4 ohms (sine) 30 W in 4 ohms (music).															
<b>Tone controls:</b>	(3400X)	Bass and treble controls are continuously variable and affect program fed to speakers only. The controls are common for the two channels. Bass: $\pm 15$ dB at 100 Hz. Treble: $\pm 15$ dB at 10,000 Hz.															
<b>Distortion:</b>		Maximum distortion in record amplifier at 0 dB meter reading: 0.5 %. Maximum distortion in playback amplifier: 0.3 % at 1 V output level.															
<b>Tape distortion:</b>		A tape recorded with a 400 Hz signal at 0 dB level gives maximum 3 % tape distortion when played back.															
<b>Wow:</b>		<table border="0"> <tr> <td>Maximum, weighted R.M.S.</td> <td>Maximum, peak DIN 45511</td> </tr> <tr> <td>7<sup>1</sup>/<sub>2</sub> ips: 0.07 %</td> <td>7<sup>1</sup>/<sub>2</sub> ips: 0.1 %</td> </tr> <tr> <td>3<sup>3</sup>/<sub>4</sub> ips: 0.12 %</td> <td>3<sup>3</sup>/<sub>4</sub> ips: 0.18 %</td> </tr> <tr> <td>1<sup>7</sup>/<sub>8</sub> ips: 0.25 %</td> <td>1<sup>7</sup>/<sub>8</sub> ips: 0.35 %</td> </tr> </table>	Maximum, weighted R.M.S.	Maximum, peak DIN 45511	7 <sup>1</sup> / <sub>2</sub> ips: 0.07 %	7 <sup>1</sup> / <sub>2</sub> ips: 0.1 %	3 <sup>3</sup> / <sub>4</sub> ips: 0.12 %	3 <sup>3</sup> / <sub>4</sub> ips: 0.18 %	1 <sup>7</sup> / <sub>8</sub> ips: 0.25 %	1 <sup>7</sup> / <sub>8</sub> ips: 0.35 %							
Maximum, weighted R.M.S.	Maximum, peak DIN 45511																
7 <sup>1</sup> / <sub>2</sub> ips: 0.07 %	7 <sup>1</sup> / <sub>2</sub> ips: 0.1 %																
3 <sup>3</sup> / <sub>4</sub> ips: 0.12 %	3 <sup>3</sup> / <sub>4</sub> ips: 0.18 %																
1 <sup>7</sup> / <sub>8</sub> ips: 0.25 %	1 <sup>7</sup> / <sub>8</sub> ips: 0.35 %																
<b>Frequency response:</b>		<p>Using Low Noise High Output Tape:</p> <table border="0"> <tr> <td>Referred to 400 Hz:</td> <td>Measured according to DIN 45511:</td> </tr> <tr> <td>7<sup>1</sup>/<sub>2</sub> ips: 30 to 22,000 Hz <math>\pm 2</math> dB</td> <td>7<sup>1</sup>/<sub>2</sub> ips: 30 to 25,000 Hz</td> </tr> <tr> <td>3<sup>3</sup>/<sub>4</sub> ips: 40 to 16,000 Hz <math>\pm 2</math> dB</td> <td>3<sup>3</sup>/<sub>4</sub> ips: 30 to 18,000 Hz</td> </tr> <tr> <td>1<sup>7</sup>/<sub>8</sub> ips: 40 to 9,000 Hz <math>\pm 2</math> dB</td> <td>1<sup>7</sup>/<sub>8</sub> ips: 30 to 10,000 Hz</td> </tr> <tr> <td>Amplifier mode: 30 to 22,000 Hz <math>\pm 2</math> dB.</td> <td></td> </tr> </table>	Referred to 400 Hz:	Measured according to DIN 45511:	7 <sup>1</sup> / <sub>2</sub> ips: 30 to 22,000 Hz $\pm 2$ dB	7 <sup>1</sup> / <sub>2</sub> ips: 30 to 25,000 Hz	3 <sup>3</sup> / <sub>4</sub> ips: 40 to 16,000 Hz $\pm 2$ dB	3 <sup>3</sup> / <sub>4</sub> ips: 30 to 18,000 Hz	1 <sup>7</sup> / <sub>8</sub> ips: 40 to 9,000 Hz $\pm 2$ dB	1 <sup>7</sup> / <sub>8</sub> ips: 30 to 10,000 Hz	Amplifier mode: 30 to 22,000 Hz $\pm 2$ dB.						
Referred to 400 Hz:	Measured according to DIN 45511:																
7 <sup>1</sup> / <sub>2</sub> ips: 30 to 22,000 Hz $\pm 2$ dB	7 <sup>1</sup> / <sub>2</sub> ips: 30 to 25,000 Hz																
3 <sup>3</sup> / <sub>4</sub> ips: 40 to 16,000 Hz $\pm 2$ dB	3 <sup>3</sup> / <sub>4</sub> ips: 30 to 18,000 Hz																
1 <sup>7</sup> / <sub>8</sub> ips: 40 to 9,000 Hz $\pm 2$ dB	1 <sup>7</sup> / <sub>8</sub> ips: 30 to 10,000 Hz																
Amplifier mode: 30 to 22,000 Hz $\pm 2$ dB.																	
<b>Crosstalk suppression:</b>		<p>Measured at 1000 Hz:</p> <p>Mono &gt; 60 dB      Stereo &gt; 50 dB.</p>															
<b>Signal/tape noise:</b>		<p>Measured at 7<sup>1</sup>/<sub>2</sub> ips and 3 % tape distortion, using Low Noise High Output Tape:</p> <table border="0"> <tr> <td></td> <td>4-track</td> <td>2-track</td> </tr> <tr> <td>IEC, A-curve, 3 % tape distortion:</td> <td>64 dB</td> <td>66 dB</td> </tr> <tr> <td>IEC, unweighted, R.M.S., 3 % tape distortion:</td> <td>57 dB</td> <td>57 dB</td> </tr> <tr> <td>DIN 45511 (Geräuschspannung):</td> <td>58 dB</td> <td>60 dB</td> </tr> <tr> <td>DIN 45511 (Fremdspannung):</td> <td>54 dB</td> <td>54 dB</td> </tr> </table>		4-track	2-track	IEC, A-curve, 3 % tape distortion:	64 dB	66 dB	IEC, unweighted, R.M.S., 3 % tape distortion:	57 dB	57 dB	DIN 45511 (Geräuschspannung):	58 dB	60 dB	DIN 45511 (Fremdspannung):	54 dB	54 dB
	4-track	2-track															
IEC, A-curve, 3 % tape distortion:	64 dB	66 dB															
IEC, unweighted, R.M.S., 3 % tape distortion:	57 dB	57 dB															
DIN 45511 (Geräuschspannung):	58 dB	60 dB															
DIN 45511 (Fremdspannung):	54 dB	54 dB															
<b>Dimensions:</b>		Length: 15 <sup>3</sup> / <sub>4</sub> " (40 cm). Height: 16 <sup>1</sup> / <sub>8</sub> " (41 cm). Depth: 7" (18 cm).															
<b>Weight:</b>	(3300X)	20 lb (9.1 kg).															
	(3400X)	23.3 lb (10.6 kg).															

## 2.0 MECHANICAL ADJUSTMENTS

### 2.1 CLUTCHES

#### 2.1.1 Checking of Clutch Torque

All measurements should be performed with empty reels and with the tape recorder operating in horizontal position. Fig. 2.1 shows the alternative measuring methods.

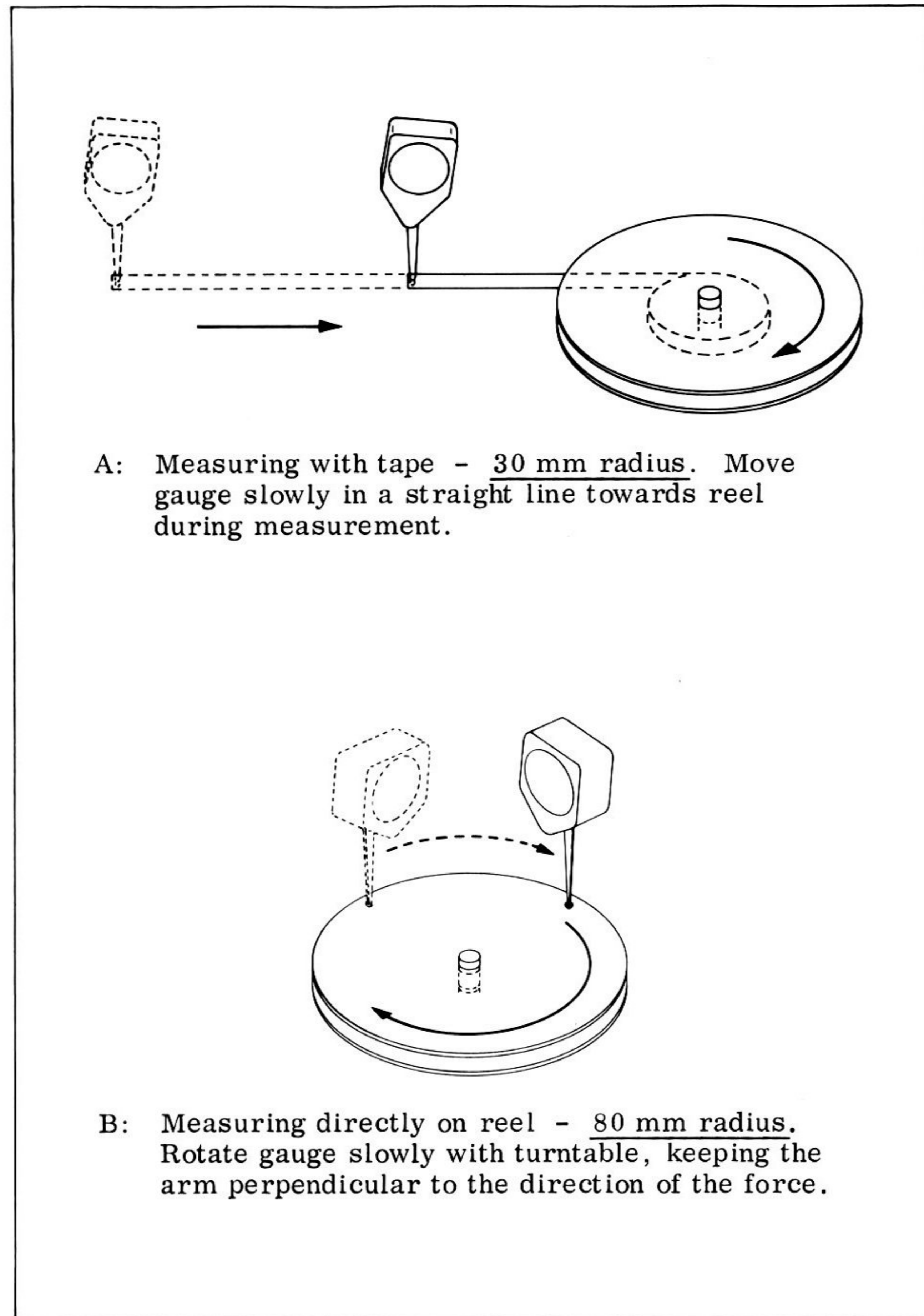

Fig. 2.1. Checking of clutch torque (shown for supply turntable). For specification, see fig. 2.2.

When using alternative A, wrap a short piece of tape on a 7" reel with core diameter of 60 mm ( $2\frac{3}{8}$ ").

In the free end of the tape, arrange a loop for the gauge arm.

In alternative B, use an empty 7" reel with a hole for the gauge drilled at 80 mm ( $5\frac{5}{32}$ ") radius.

**Note:** During normal operating conditions the bearing friction will add to or be subtracted from the torque, depending on the direction of rotation. When measuring small forces as for instance in row 1 and row 2 in fig. 2.2, the reel should be allowed to rotate slowly in the direction of the clutch torque while the measurement is performed, in order to obtain the specified values.

When using spring gauges manufactured by Halda, see fig. 2.1, the gauge arm and not the housing must be perpendicular to the direction of the force.

#### 2.1.2 Take-up Turntable

##### Normal Forward Drive

Remove all top covers in order to uncover the mechanical parts. Set the operating lever in normal forward drive. Put a piece of paper between the left hand tape guide post and the light source for the photoelectric end-stop sensor in order to keep the motor switched on. Look horizontally underneath the turntables and check that the distance between the brake pads underneath the take-up turntable 991048 and the friction wheel 991009 is 0.5–0.9 mm (0.02"–0.035"). If necessary, adjust screw A as shown in fig. 2.3. The take-up force to be obtained can be found in fig. 2.2, row 1.

Text Ref.	Clutch Torque/Tension	Right/Left	Operating Lever Position	Force with 30 mm radius	Force with 80 mm radius
Row 1	Take-up	R	→	40g— 80g*	15g— 30g*
Row 2	Tape tension	L	→	0 — 22g	0 — 8g
Row 3	Winding torque	R	→→	240g—670g	90g—250g
		L	←←		

Fig. 2.2. Clutch torque/tension specification.

\* It is normal that the winding force increase 20–30 % after some time of continuous operation.

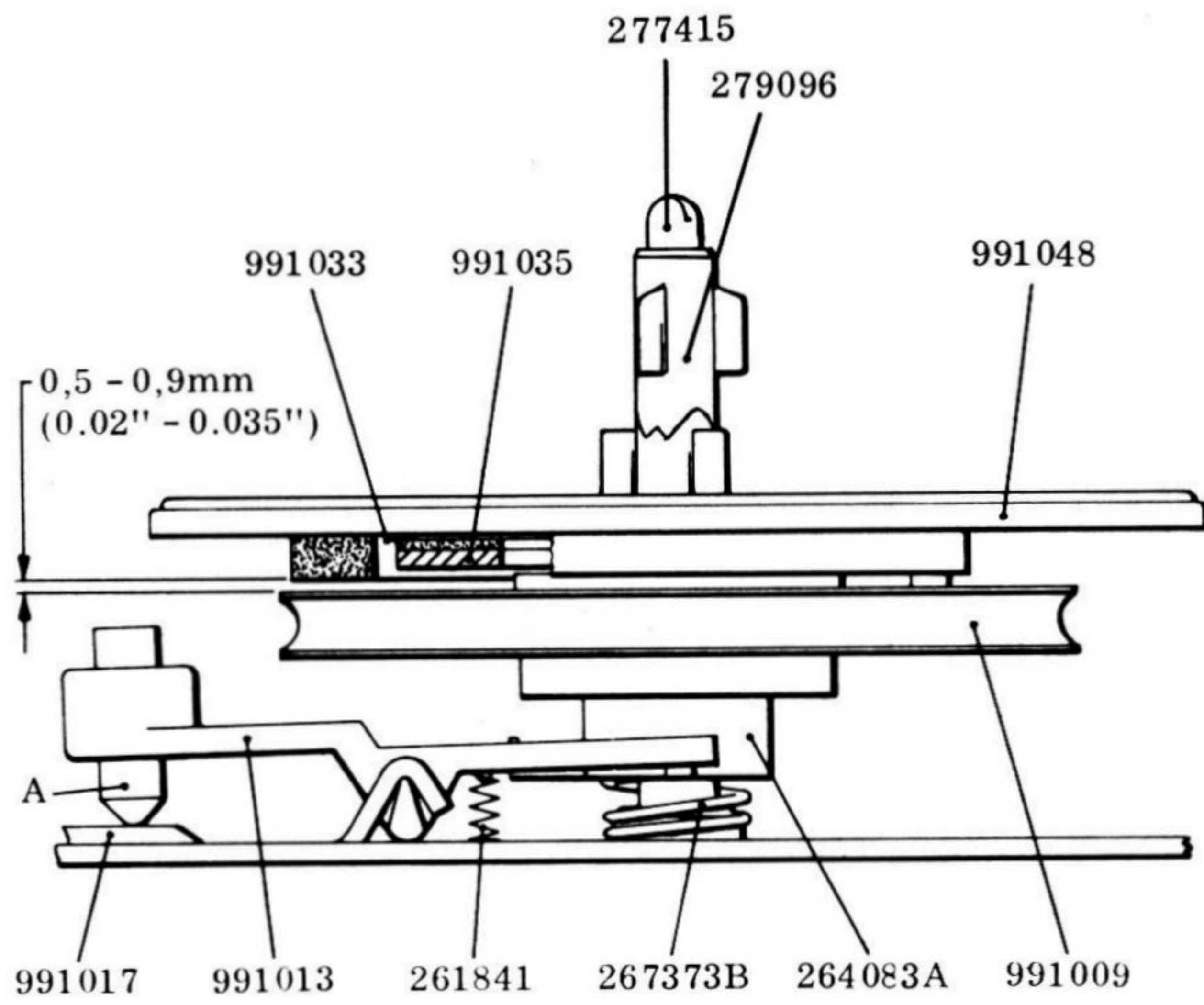

Fig. 2.3. Take-up turntable, operating lever in normal forward drive position.

### Fast Forward Winding

The forward winding torque can be found in fig. 2.2, row 3. If the force departs from the specification given in the table, check that the tension spring of 267373B is correct. If necessary change the tension of the spring, or the spring must be replaced. Furthermore, check that there is clearance of minimum 0.1 mm (0.004") between the studs on the bushing 264083A and the arm 991013, see fig. 2.4.

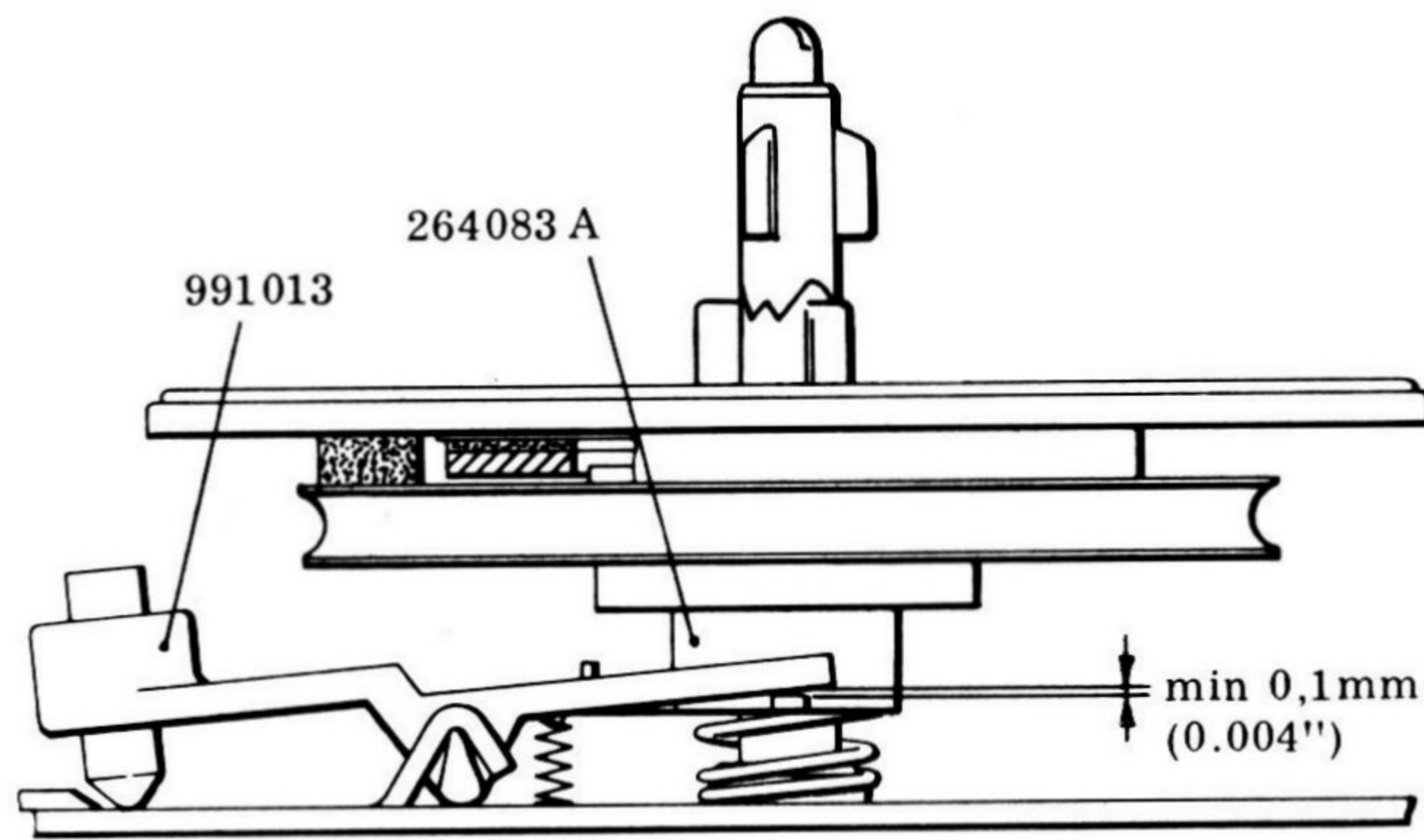

Fig. 2.4. Take-up turntable, operating lever in forward winding position. Clearance between tube 264083A and lever 991013.

### 2.1.3 Supply Turntable

#### Tape Tension

The correct tape tension can be found in fig. 2.2, row 2.

#### Fast Rewind

The rewind force can be found in fig. 2.2, row 3. If the force deviates from the specifications given in the table, alter the tension of spring 261805A, see fig. 2.5, or the spring must be replaced. The difference between the forces measured in fast forward winding and rewinding should be less than 130 g (measured

at 30 mm radius), or 50 g (measured at 80 mm radius). If the difference exceeds these values, the tension of spring 261805A or 267373B must be altered. It can also be checked that the forces are sufficient by operating the tape recorder in vertical position with a full 7" reel on the take-up turntable.

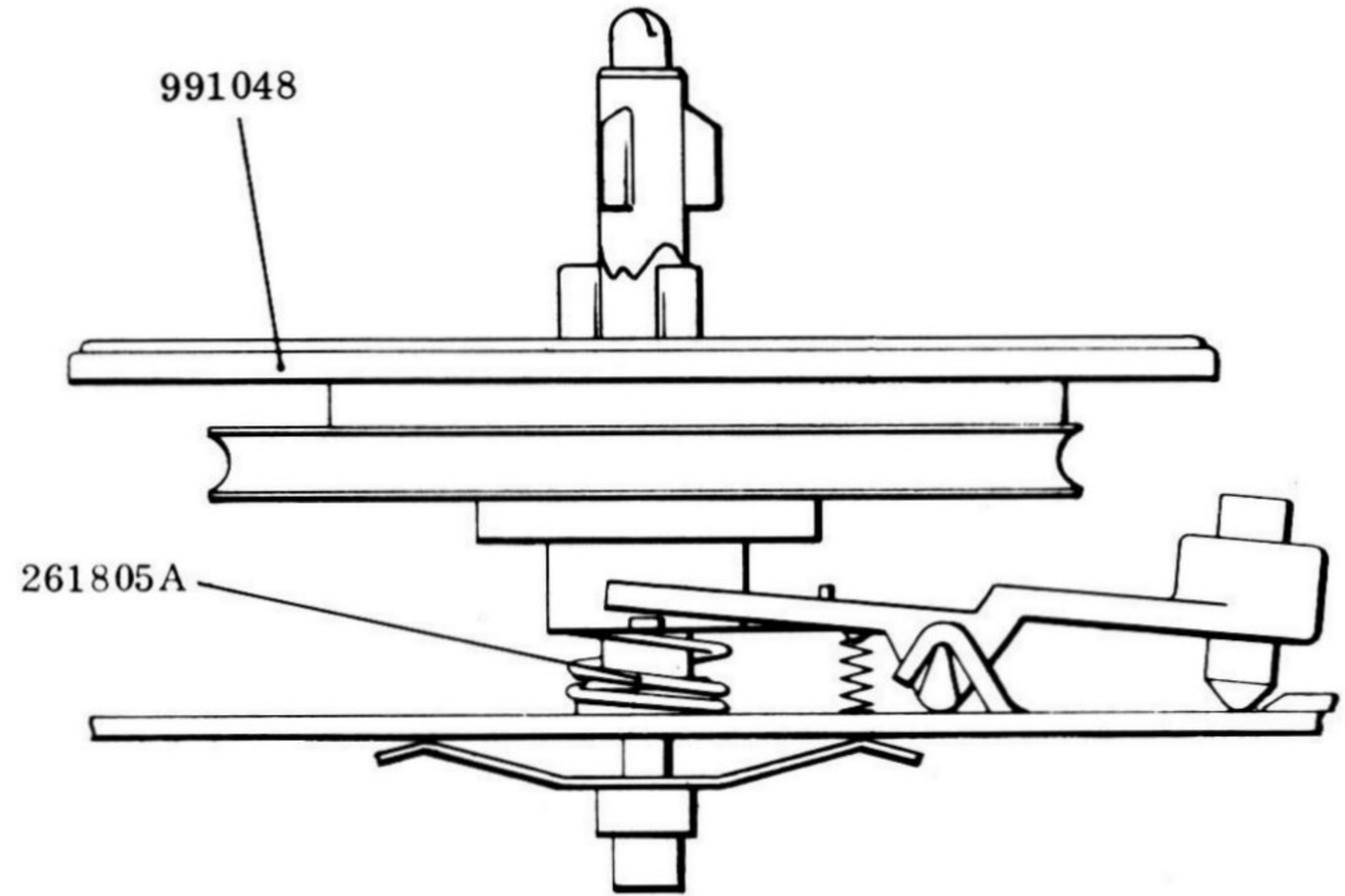

Fig. 2.5. Supply turntable, operating lever in reverse winding.

## 2.2 BRAKES

This adjustment procedure is equal on both turntables but reference is given to the take-up turntable, see fig. 2.6. Set the operating lever to position normal forward drive. Check that the clearance between the brake pad and the turntable is approximately 1 mm (0.04"). If necessary, adjust screw D.

Set the operating lever to fast forward winding, alternatively fast rewinding. Check that the clearance between screw C and the moving acetal part 991017 on the operating arm is 0.5-1 mm (0.02"-0.04"). Adjust screw C if necessary.

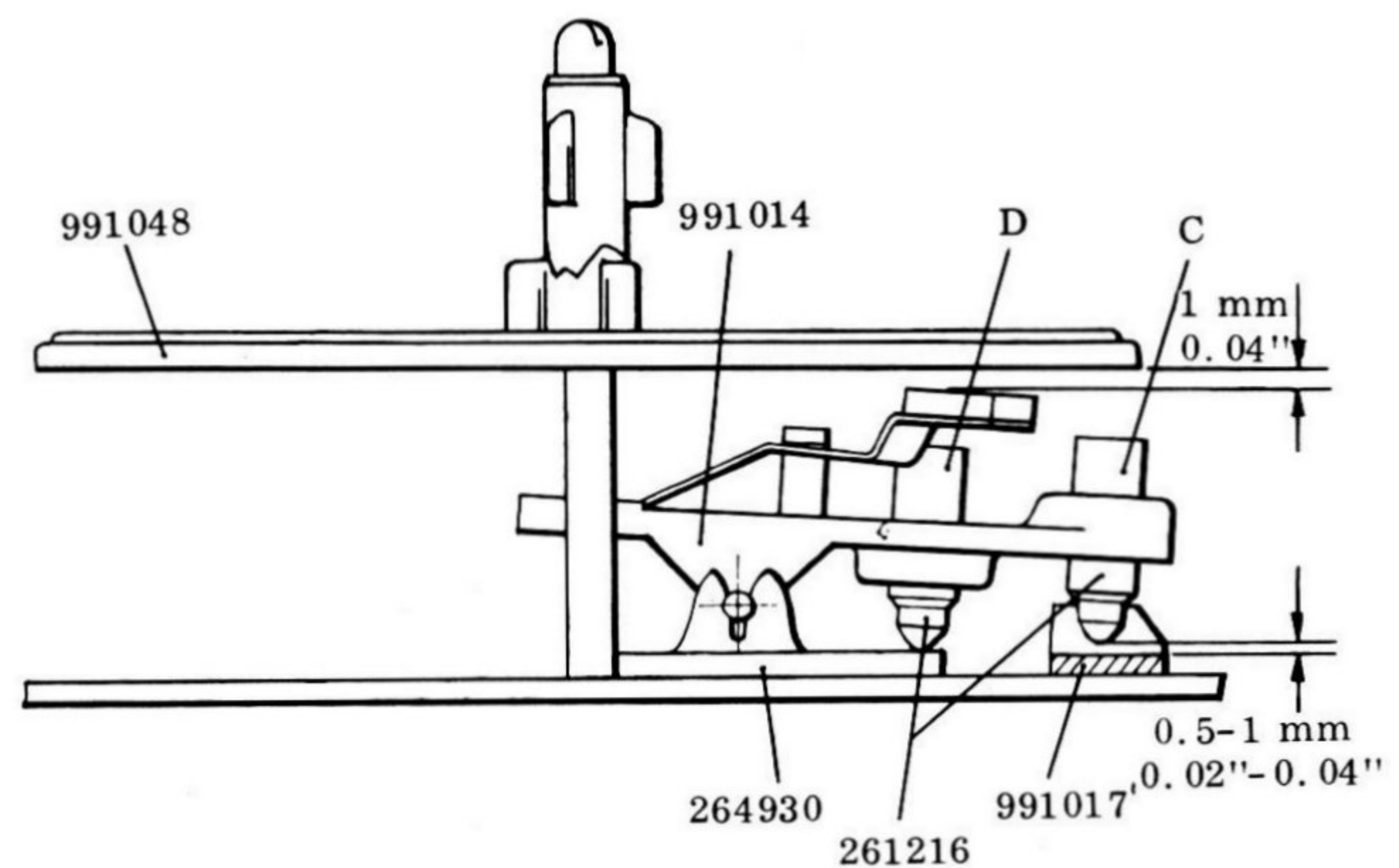

Fig. 2.6. Brake adjustment (shown for take-up turntable).

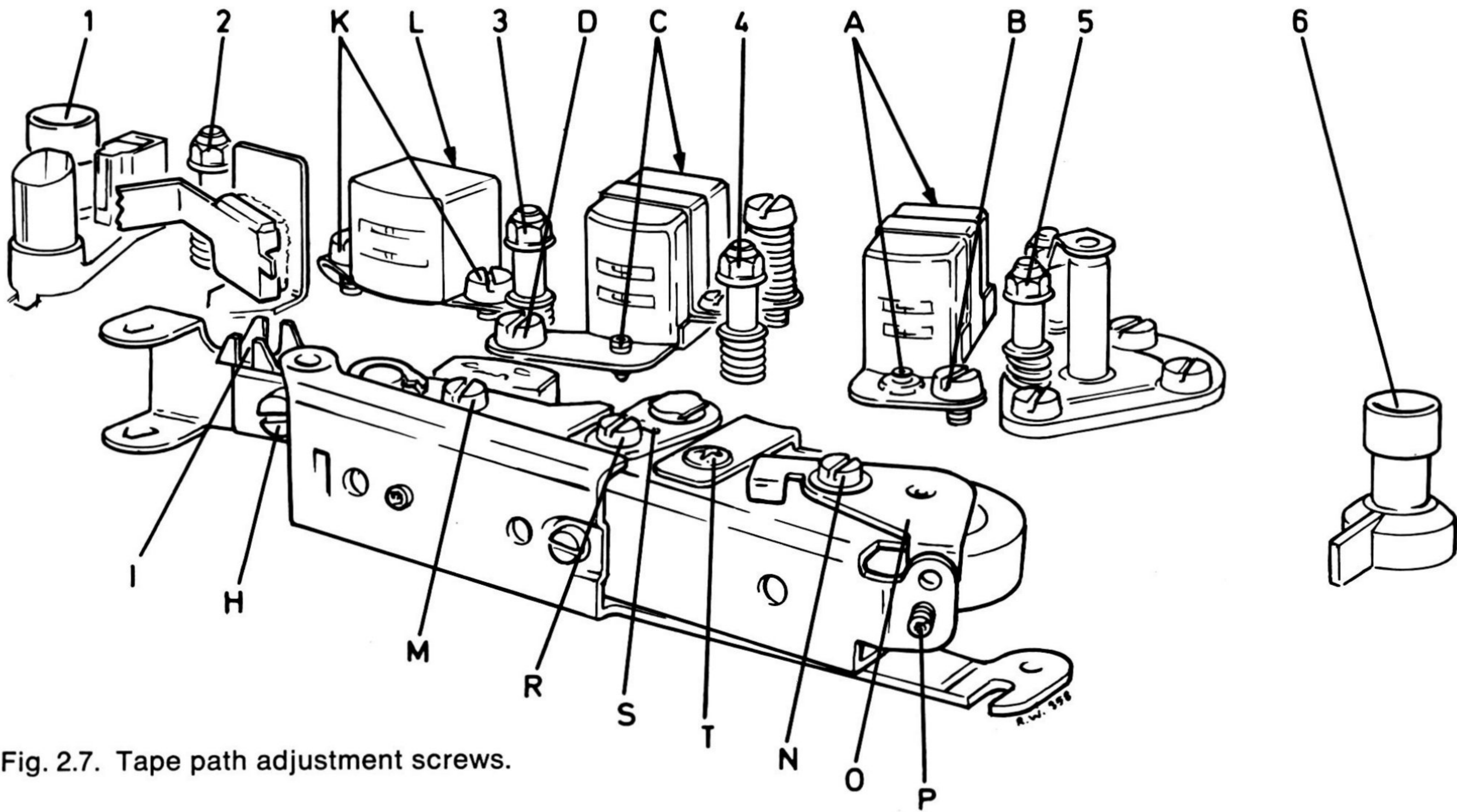

Fig. 2.7. Tape path adjustment screws.

## 2.3 TAPE PATH

After replacement of one single part in the tape path, it may often be necessary to adjust the replaced part only. If, however, more parts have to be adjusted, a complete checking and adjustment of the entire tape path must be performed. The adjustments must be carried out in the same sequence as explained below in order to eliminate the effects of mutual interaction. The tape path must be thoroughly cleaned before adjustment is carried out. Use tape without any defects.

**Note:** If the heads have grooves caused by wear, adjustment of the heads should be avoided.

Seal all screws in the tape path after the adjustment.

### 2.3.1 Visual Check

Load the recorder with a tape, and move the operating lever slowly to the normal forward drive position. Check that the bias head neither touches the height adjustment screws C, see fig. 2.7, on the record head mounting plate, nor presses the tape against the record head. Also check that the bias head is parallel to the record head.

Operate the start/stop knob, and check that the tape runs within the rims of the pinch roller rubber without flickering on neither side of the pinch roller.

Check that the height positioning of the tape guide posts is correct. It can be tolerated that the tape touches the guide posts when the recorder is in normal forward drive, or as the drive mechanism is engaged. The tape must, however, by no means bulge at the flanges.

### 2.3.2 Capstan Adjustment

The capstan should be perpendicular to the upper mounting plate. This should be checked with special tool No. 5, see fig. 2.8.

The special tool No. 5 is placed on the capstan after having removed the flywheel thrust spring 993914. One leg of tool is pointing towards the front of the recorder and the two other legs out to the sides. All three legs must simultaneously be in contact with the mounting plate.

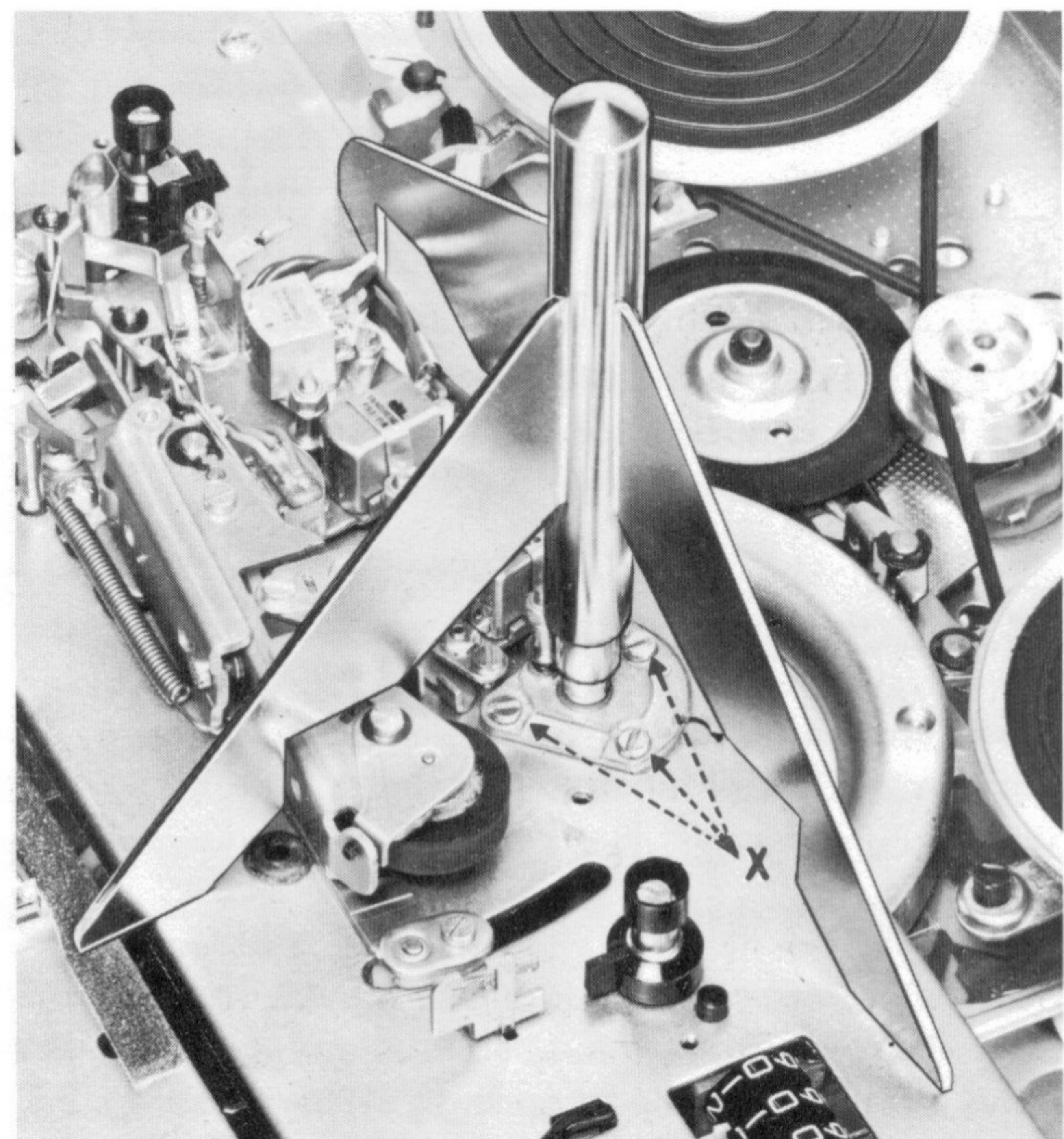

Fig. 2.8. Adjustment of capstan with special tool No. 5.



For adjustment, loosen the three mounting screws (X) for the bearing housing 991027, and move the bearing to bring the capstan in vertical position.

The bearing can also be turned within a narrow angle. Since the guide post 283522 is attached to the bearing housing, the tape encircles the capstan over an angle determined by the rotary adjustment of the bearing.

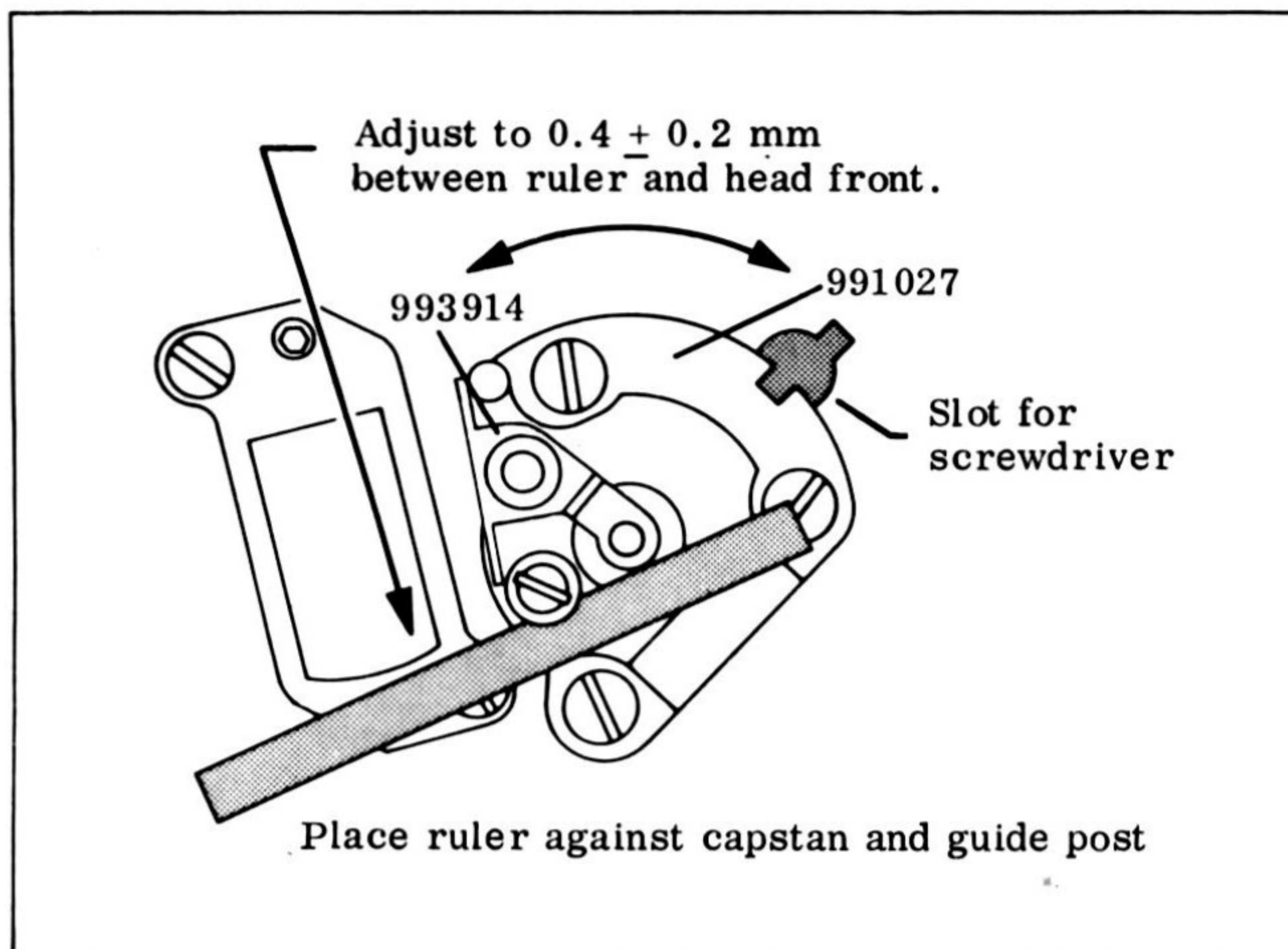

Fig. 2.9. Adjustment of tape encircling.

The adjustment can be performed with a ruler placed against the capstan and the tape guide post as shown in fig. 2.9. Check that the capstan is still perpendicular after readjustment of the encircling angle. If necessary, readjust as described above. When adjustment is completed, put back flywheel bearing 993914, and adjust at the distance between capstan and the flywheel thrust spring acetal piece to be 0.1 mm (0.004") when the recorder is in horizontal position.

### 2.3.3 Pinch Roller Adjustment

Prior to the electrical adjustment of the heads, it is essential to make the tape run without sideways movement through the tape path and that the pinch roller wheel is parallel to the capstan.

**Note:** After each attempt to adjust the pinch roller, stop the tape motion with the operating lever, neutral position. Then restart and check the result.

### Zenith Adjustment

Insert a tape and set operating lever to normal forward drive. Check by visual inspection that the capstan and the pinch roller wheel are parallel. If not, adjust by first loosening screw (N), see fig. 2.7, and then adjust with set screw (P) until the wheel and capstan are parallel. Tighten screw (N).

### Azimuth Adjustment

This adjustment is performed when the recorder is loaded with a tape free from damage, and when the operating lever is in normal forward drive position.

Loosen screw (N) and move the bracket (O) until the tape is running evenly through the tape path. Brake the supply reel lightly and check that the tape does not move up or down in the tape guide 5. If necessary, readjust azimuth.

As azimuth and zenith adjustments affect each other, recheck zenith adjustment.

Align in sequence guide posts 5, 2, 3 and 4 until the tape is slightly touching one of the flanges. Adjust without tape movement.

### 2.3.4 Heads

Out of all the head adjustments, it is only the zenith adjustment (parallelity of the head front and capstan) that has any effect on the tape guidance, see fig. 3.1. Check, and if necessary adjust zenith for playback head, record head, erase head, bias head and the tape rest 254844A, see fig. 2.10. The zenith alignment is referred to the capstan. If the special tool for checking the zenith alignment is not available, a ruler and a spacer can be used for a rough check as shown in fig. 2.11. The spacer must have an absolutely even thickness throughout its length to obtain a good result.

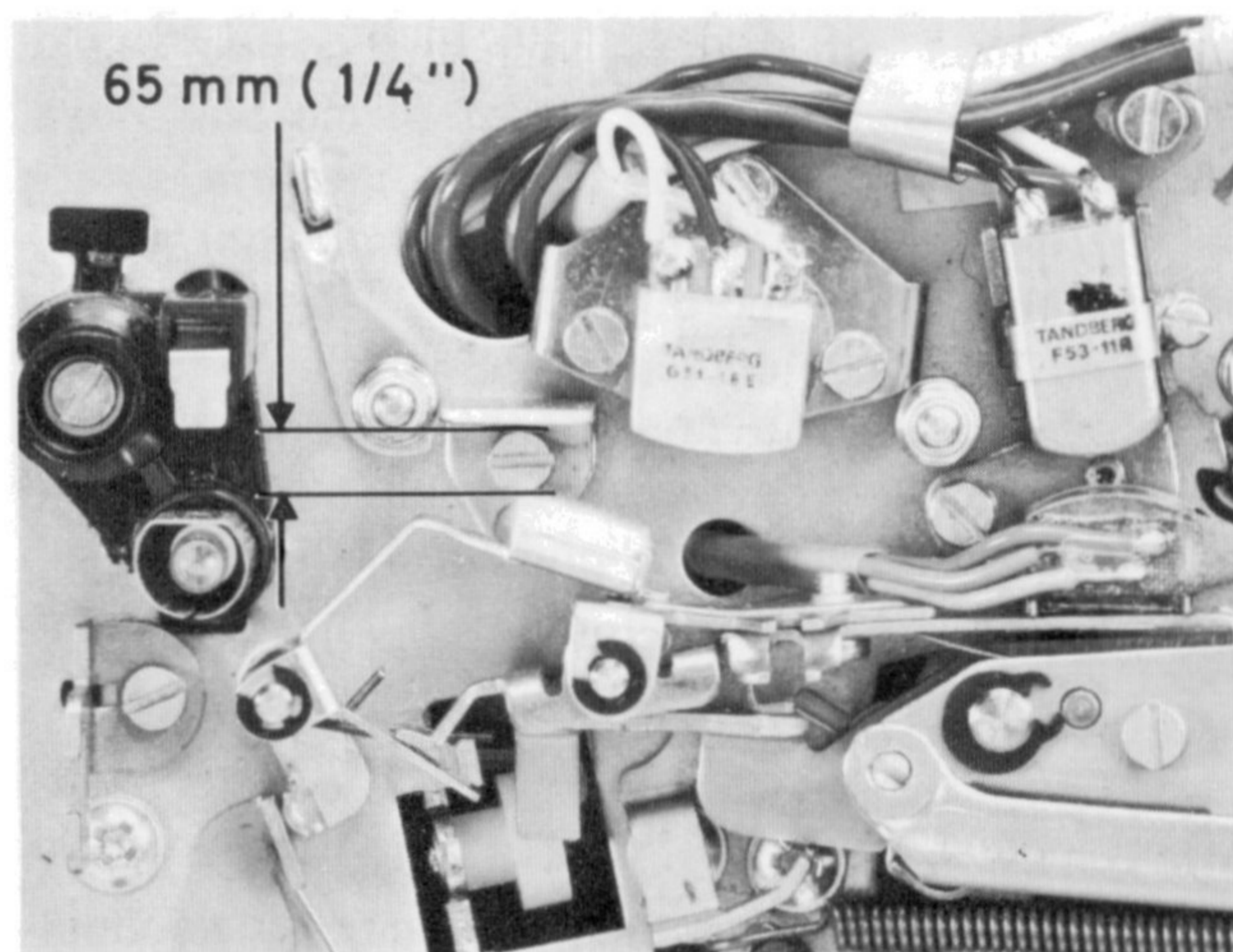

Fig. 2.10. Clearance between pressure pad and tape rest.

It may be necessary to remove the right hand tape guide post to give room for the ruler.

The zenith position of the heads can be adjusted with the head screws, while taking care to maintain the head azimuth and height position. The tape rest can be bent with a flat-nosed plier if necessary. In order not to scratch the tape rest, protect it with a piece of paper during adjustment.

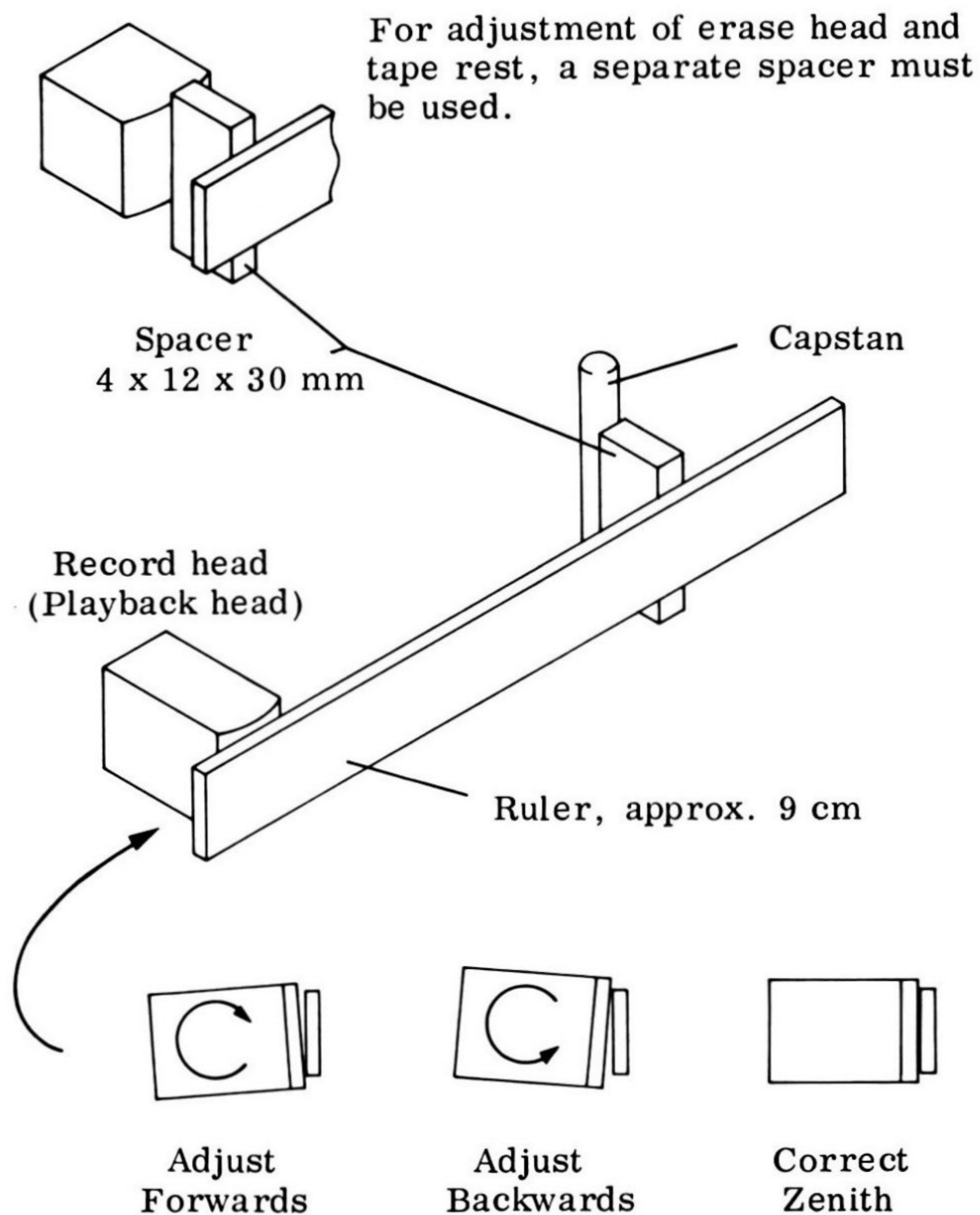

Fig. 2.11. Checking of head azimuth with ruler and spacer.

The bias head should be parallel to the front of the record head. If necessary, twist the arm holding the head to obtain the required parallelity. Ensure that the tape does not interfere with the spacer ribbon along the upper and lower edges of the bias head, and adjust if necessary by bending the arm. Check that the bias head does not touch the height adjustment screw on the record head.

Note that the above checks are only related to guiding of the tape. The final head adjustment (paragraph 3.0) includes height and azimuth alignment and must be performed after alignment of the tape path in order to ensure that the zenith adjustment is not upset.

### 2.3.5 Pressure Pad

Set the operating lever in neutral position. The clearance between the pressure pad 993904 and the tape rest 254844A should then be approximately 6.5 mm (1/4") as shown in fig. 2.10. If necessary, bend the arm 993904 to obtain the required clearance, see fig. 2.12. Set the operating lever to normal drive position. The tension should then be 80–100 g (2.8–3.5 oz.), when using tension gauge of Halda type and when measured at the end of the pressure pad arm, see fig. 2.13. When adjusting the tension, bend spring 251489A with a thin-nosed plier as shown in fig. 2.14. Check the zenith position of the pressure pad and the entire width of the tape is covered by the pad.

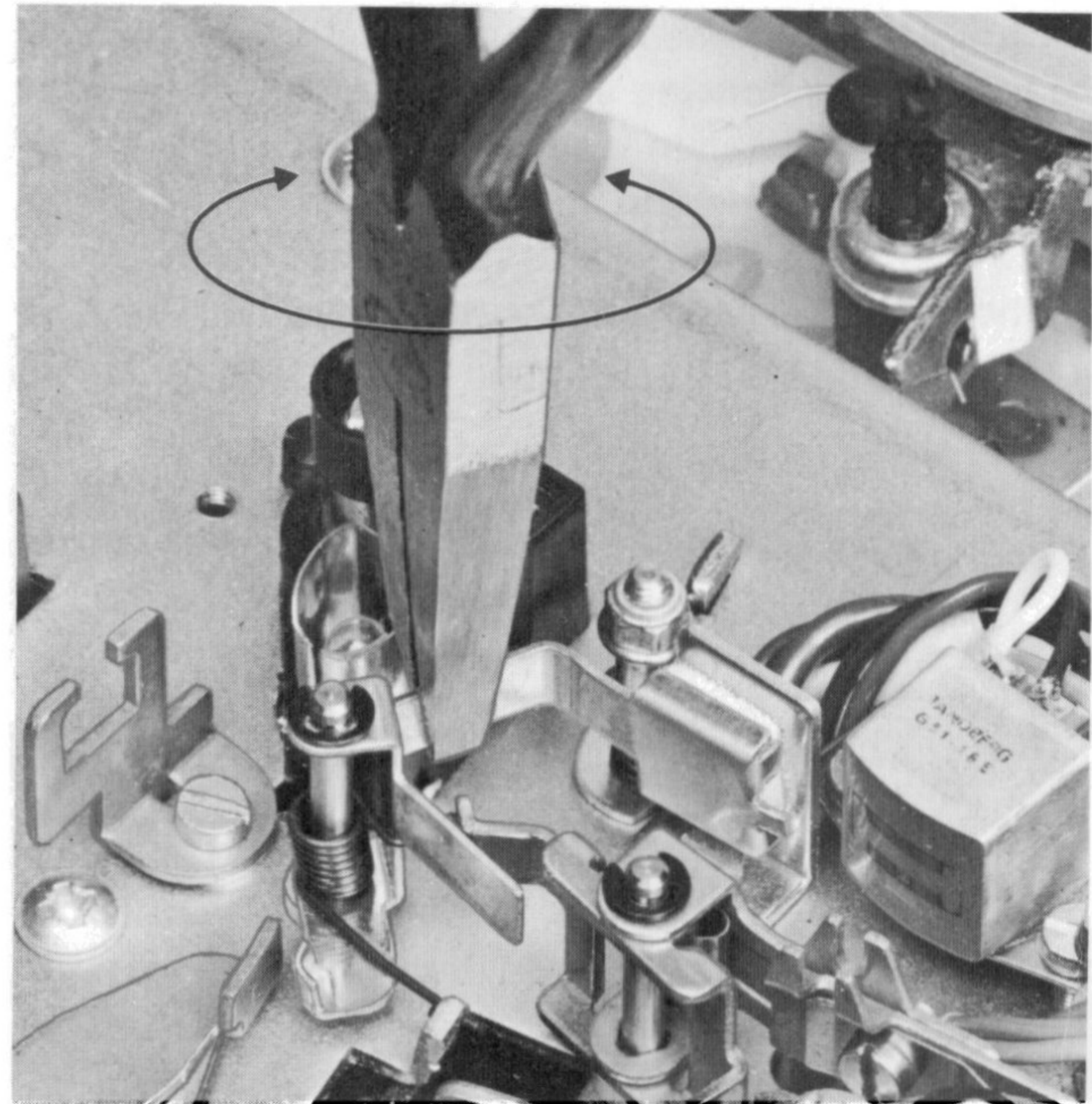

Fig. 2.12. Adjustment of clearance between pressure pad and tape rest.

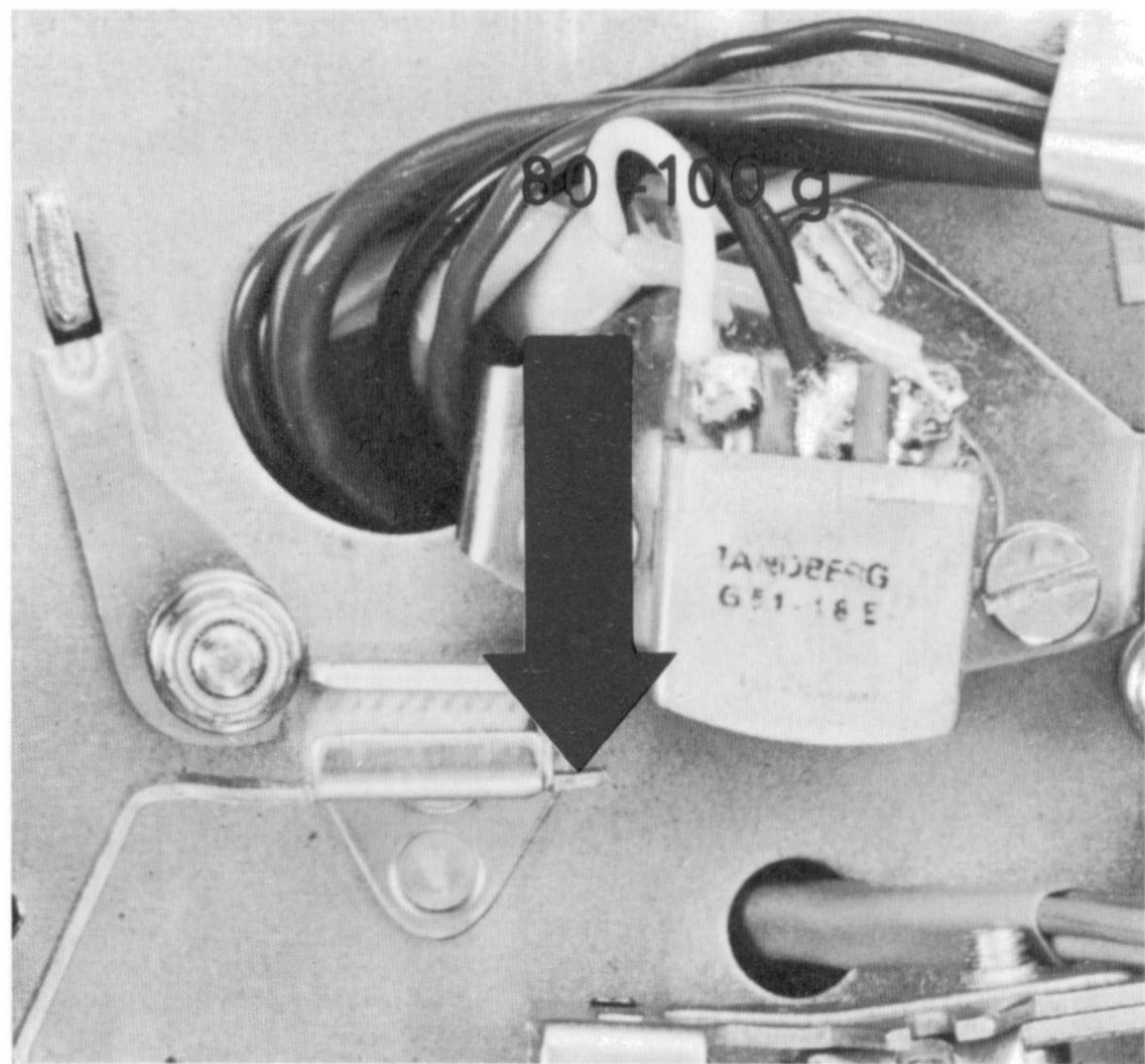

Fig. 2.13. Checking of pressure pad tension.

### 2.3.6 Inertia Idling Roller

**Note:** After each attempt to adjust the inertia idling roller, stop the tape motion with the operating lever by moving to neutral. Then restart and check the adjustment.

#### Zenith Adjustment

Set the operating lever to normal forward drive with tape on the recorder. Loosen screw R, see fig. 2.7, on the inertia idling roller adjustment plate 291180. Insert a screwdriver in slots of the plate and press forwards or backwards until the idling roller is parallel with the heads. Note that the tape does not bulge on any side of the roller. Then tighten the screw.

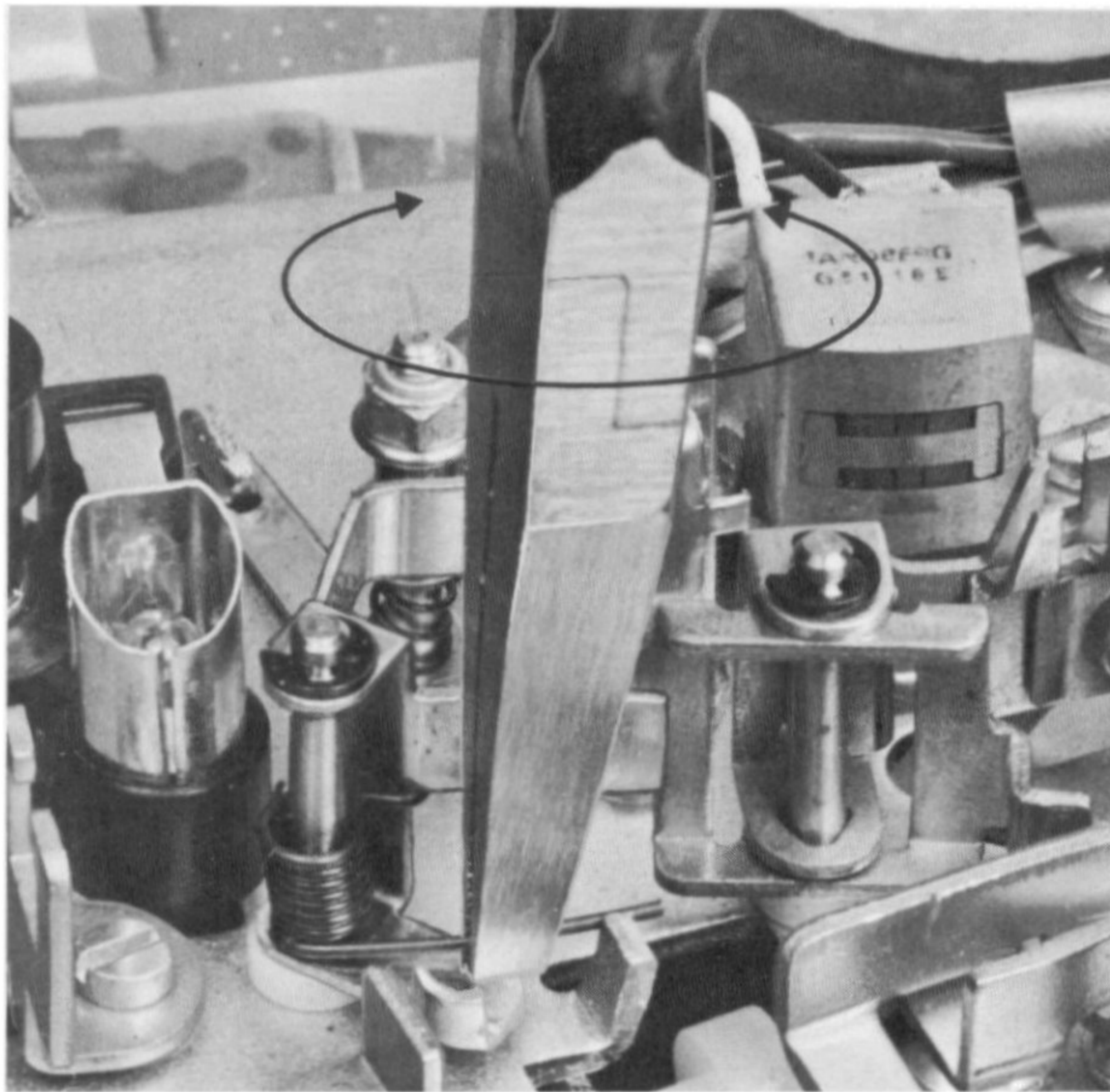

Fig. 2.14. Adjustment of pressure pad tension.

#### Azimuth Adjustment

Insert tape and set the recorder to normal forward drive at  $7\frac{1}{2}$  ips tape speed. Adjust with a screwdriver as shown in fig. 2.15 to obtain a very slight tilt of the roller ( $1^\circ$ – $2^\circ$ ) towards the left. Perform adjustment as follows:

Adjust the upper bearing to the left until it can be clearly seen that the tape hits the upper flange on the tape guide post nearest the inertia idling roller. Then move the bearing slightly towards the right, using a screwdriver, until the tape barely hits the lower flange of the tape guide post, see fig. 2.16.

If the tongue is released in this position, it will move back far enough to give the roller the desired tilt towards the left. When properly adjusted, the tape will move away from the lower flange and barely touch the upper flange on the guide post to the left of the inertia idling roller when the tongue is released.

To facilitate checking, place a light source above and behind the tape recorder, and look from the front against the lower flange on the guide post.

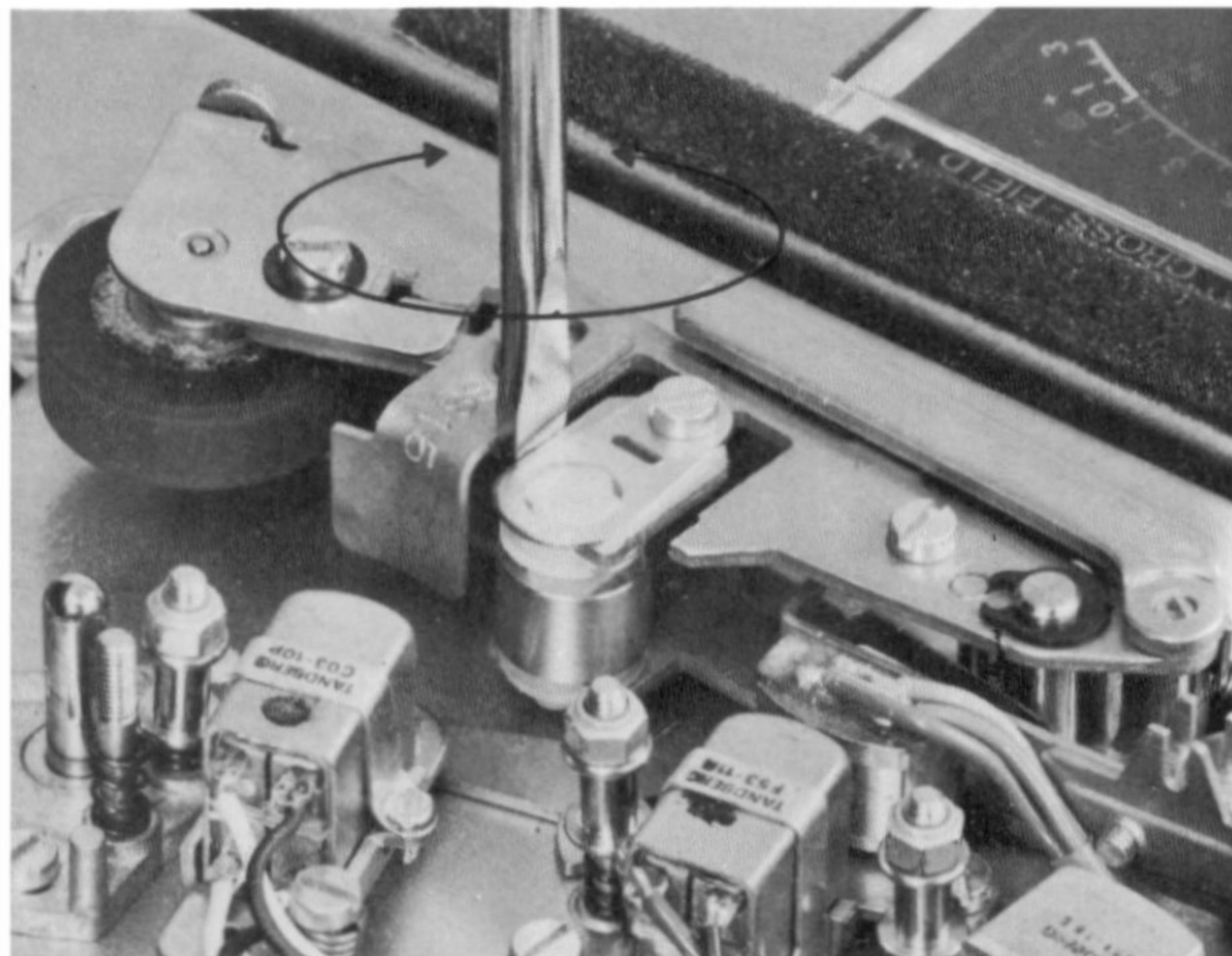

Fig. 2.15. Azimuth adjustment of inertia idling roller.



Fig. 2.16. Azimuth adjustment of inertia idling roller.

### 2.3.7 Checking and Readjustment of Tape Guide Posts

By giving the inertia idling roller a light inclination (see paragraph 2.3.6), the roller will give the tape a light upward lift causing the tape to touch the upper flange on the tape guide posts 2, 3 and 4, see fig. 2.7. The result is a precise guidance of the tape past the heads. For a best possible result, readjust the tape guide posts 2, 3 and 4 so that each one slightly touches the tape with the upper flange, taking care to avoid that the tape bulges at any of the guide posts. The guide posts are adjusted in the sequence 4, 3, 2, see fig. 2.7, while the tape is moving at  $7\frac{1}{2}$  ips. Repeat the adjustment until the tape guidance is as smooth as possible.

## 2.4 LUBRICATION

### 2.4.1 Motor

The motor should be lubricated after every 3000 hours of operation. Apply only one drop of Teresso oil No. 43 or 47 from Esso.

### 2.4.2 Self-lubricating Bearings

Turntables, flywheel, and transfer wheel are mounted in self-lubricating bearings and should under normal conditions not need any attention. If for some reason lubrication appears to be necessary, use Teresso oil No. 43 or 47 from Esso.

**Note:** Do not use more than one drop of oil in each bearing, as excessive oil may penetrate into the drive mechanism and disturb friction conditions.

## 3.0 ELECTRICAL CHECKS AND ADJUSTMENTS

### 3.1 ERASE AND BIAS CIRCUITS

#### 3.1.1 Oscillator Frequency

By means of a coil with about 10 turns placed around the erase head, couple a frequency meter or counter inductively to the oscillator circuit. Set the recorder for recording and if necessary adjust C502 to obtain a frequency reading of 85.5 kHz.

Alternatively, use a calibrated longwave receiver tuned to 256.5 kHz (3. harmonic of oscillator frequency).

#### 3.1.2 Checking of Erase Voltage

Set the recorder for stereo recording and connect an AC voltmeter to the upper half of the erase head by means of a low capacitance probe. The voltage should be 80–120 V. Then check that the same voltage appears across the lower head half.

Set the recorder for recording on channel L and check the voltage across the upper half of the erase head. The deviation from the voltage measured in stereo should not exceed 10 V. Proceed similarly for recording on channel R.

#### 3.1.3 Bias Current

Set the recorder for stereo recording and measure the voltage across the upper half of the bias head by means of an AC voltmeter. Adjust the voltage to 22 V by means of R400. Check the voltage across lower half of the head and adjust with R401 to 22 V. Then demagnetize heads and tape path.

## 3.2 HEAD ALIGNMENT WITH TANDBERG TEST TAPES, MODELS 3341X AND 3441X – FOUR TRACK

### 3.2.1 Playback head

Connect an AC voltmeter to each one of the outputs (RADIO or LINE) and set both SOURCE/TAPE buttons to position TAPE.

#### Height Adjustment

Play back Tandberg test tape No. 1. This is a full track prerecorded tape with 1000 Hz recorded at 7½ ips and with area corresponding to track 3 reduced by approx. 30 dB. Adjust the height of the playback head by means of the screws (A), see fig. 2.7, until minimum output is obtained from track 3 (channel R), while endeavouring to maintain the headfront parallel to the tape.

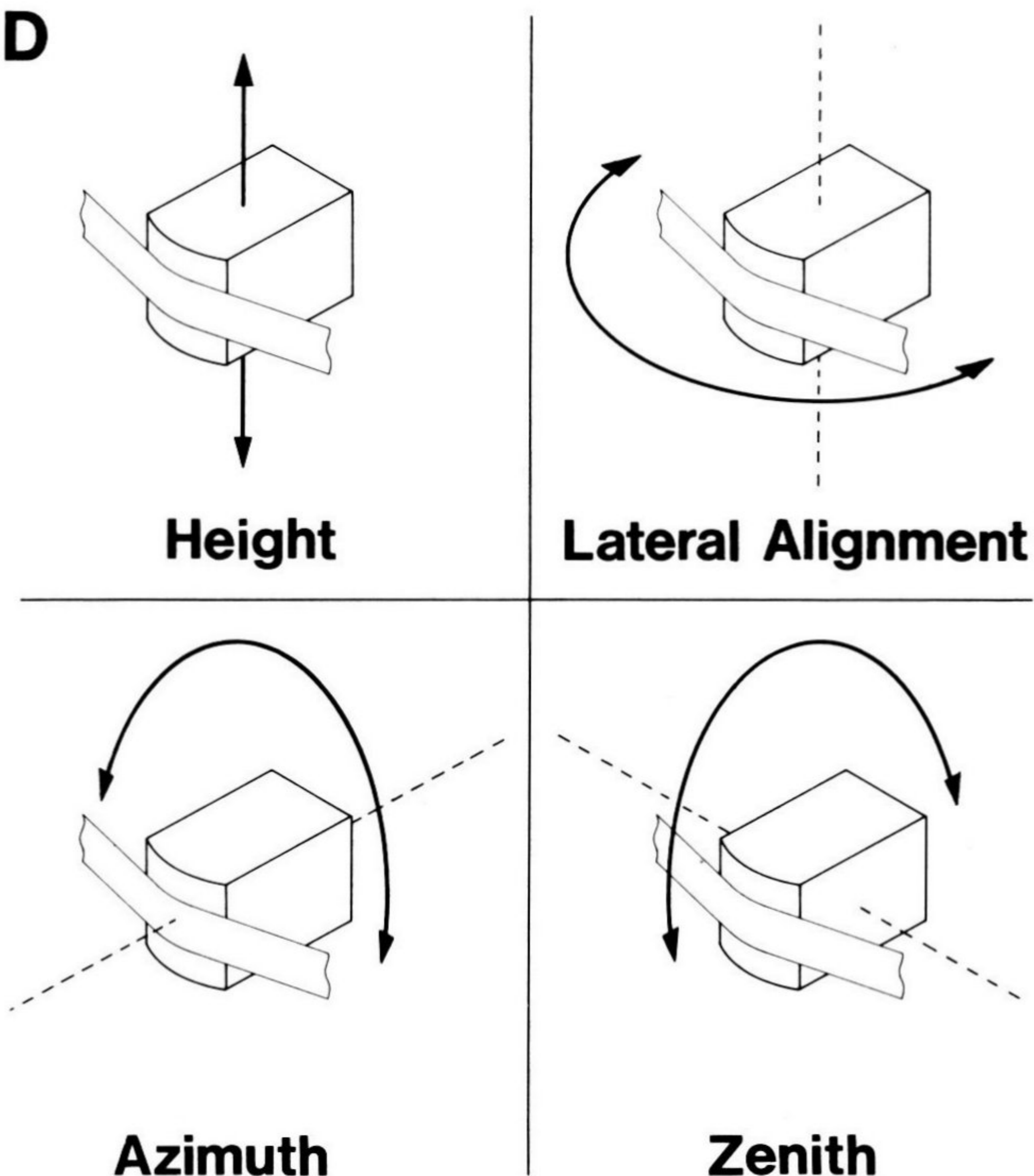

Fig. 3.1. Head adjustment positions.

#### Azimuth Adjustment

Play back Tandberg test tape No. 2. This is a full track prerecorded tape with 10,000 or 15,000 Hz recorded at 7½ ips. Adjust the azimuth position of the playback head by means of screw (B), see fig. 2.7, until maximum indication on the voltmeter is obtained on both channels, or best compromise.

### 3.2.2 Record Head

#### Height Adjustment by Visual Inspection

Insert a new tape, and start the recorder in normal forward drive. Check visually that the tape appears to run parallel with the upper track of the record head, with a play of approx. 0.1 mm (0.004"), see fig. 3.2. If necessary adjust the height with screws (C), see fig. 2.7, while endeavouring to maintain the headfront parallel to the tape.

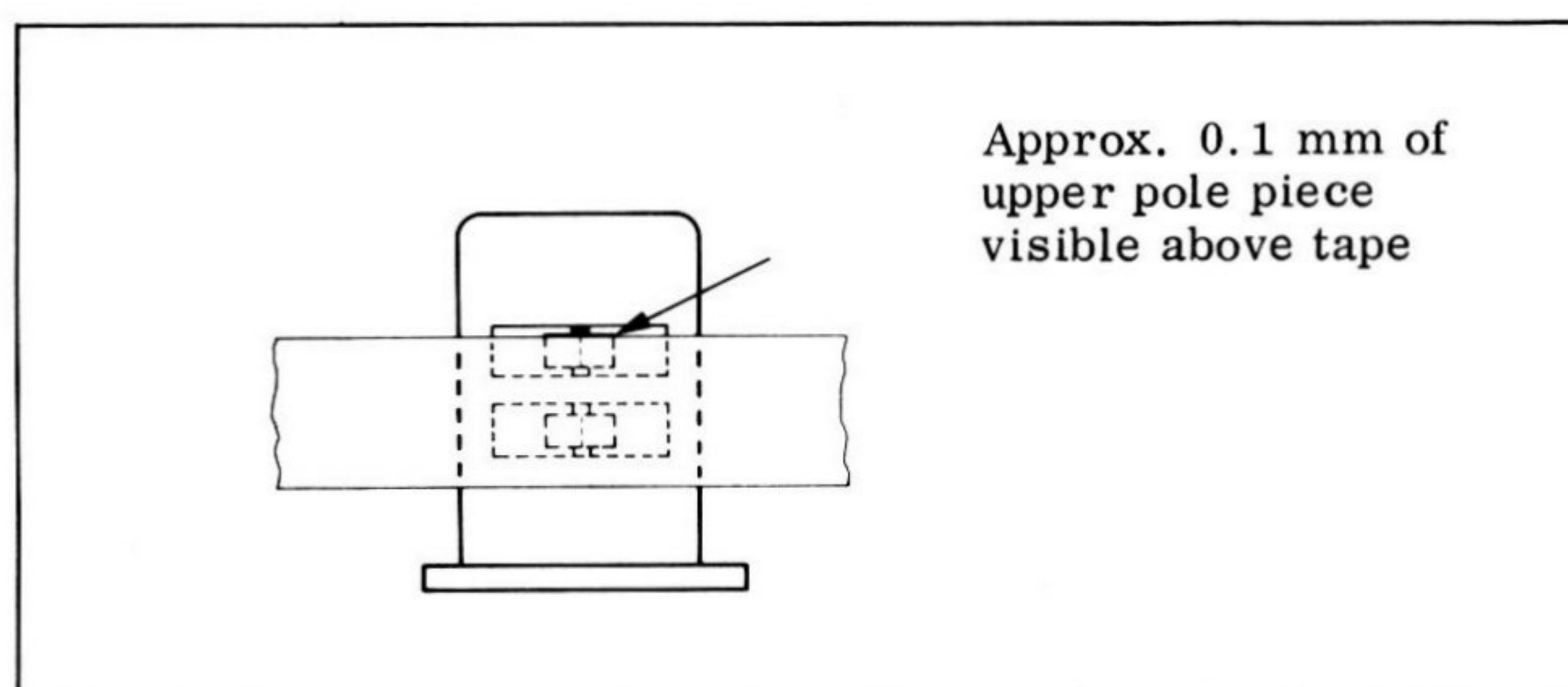
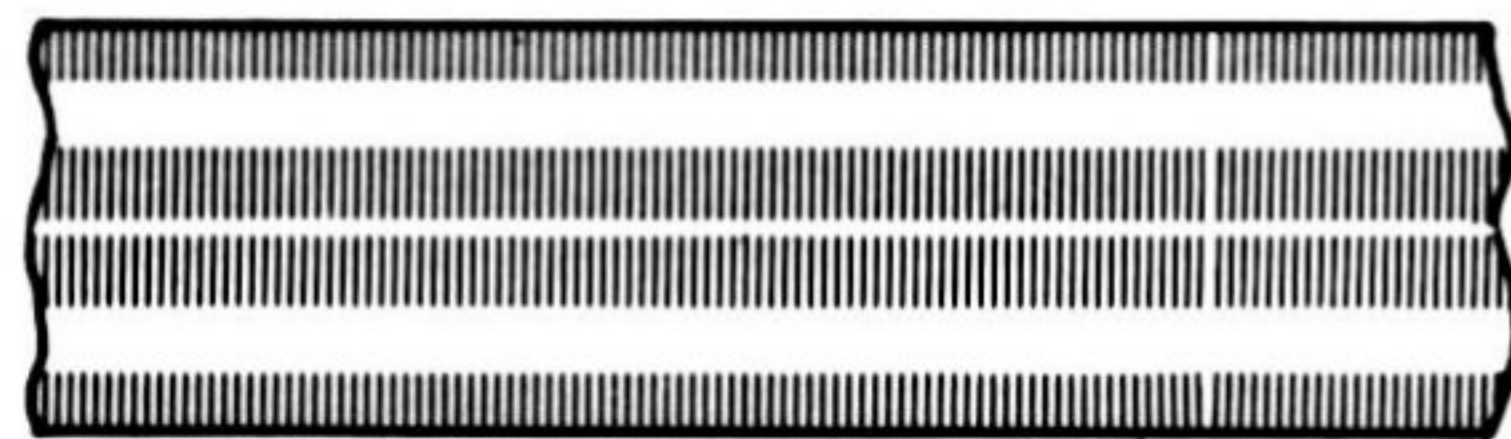
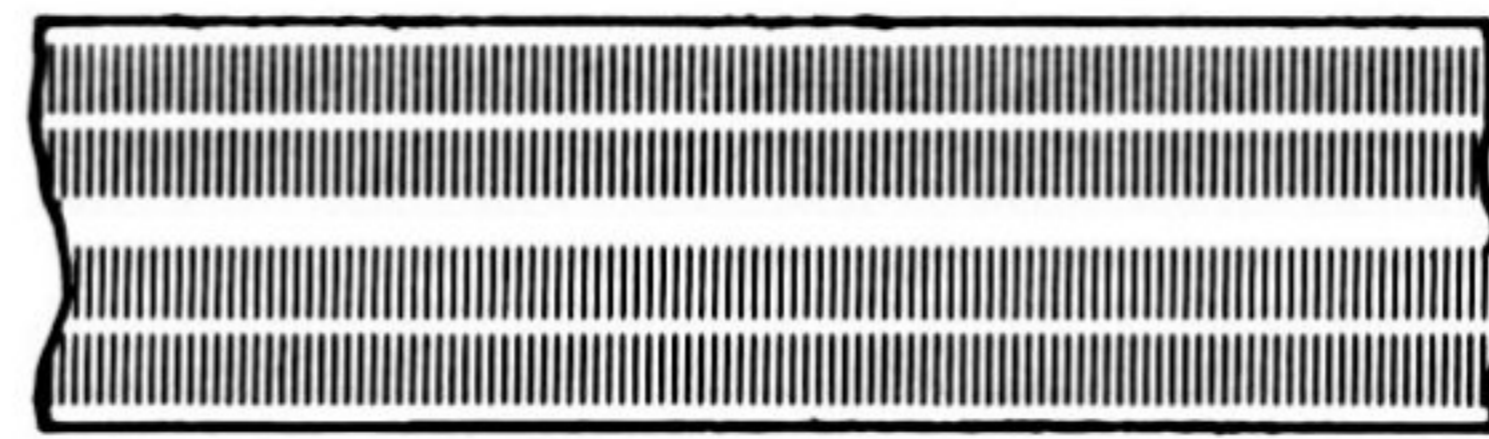

Fig. 3.2. Four-track record head, coarse height adjustment.

Too high.



Too low.



Correct.

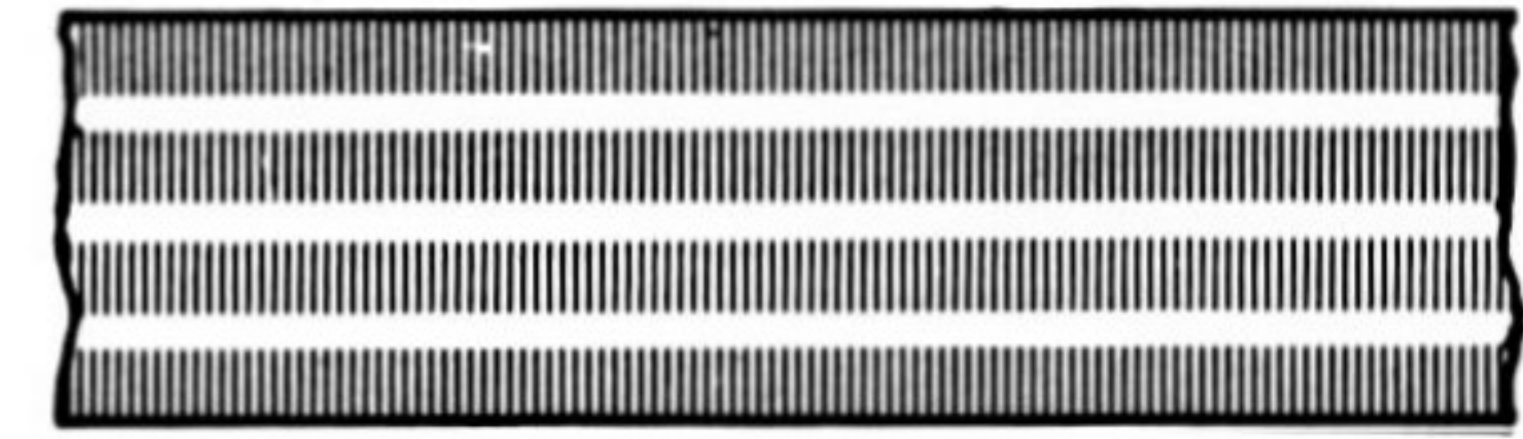

Fig. 3.3. Track measurement, four-track record head.

#### Height Adjustment by Track Measurement

Record in stereo a 1000 Hz signal well above normal level, first in one direction, then in the opposite. Cut off a length of tape and dip it into a solution of fine grained iron oxide powder and alcohol (Magna See). The tracks will then be visible as four dark stripes with spacings in lighter shade. Fig. 3.3 shows the correct pattern on the tape and the patterns obtained when the head is positioned either too high or too low. Adjust as above and perform a new track measurement.

#### Azimuth Adjustment

Load a new tape into the recorder and record at tape speed 7½ ips a 15,000 Hz signal in stereo. Set the SOURCE/TAPE buttons to position TAPE. Adjust both INPUT LEVEL potentiometers for approx. 150 mV reading on AC voltmeters connected to the LINE or RADIO outputs. Adjust the record head azimuth screw (D), see fig. 2.7, for maximum output from both channels simultaneously or best compromise.

### 3.2.3. Bias Head

#### Vertical Adjustment

Move the operating lever slowly to the normal forward drive position and check that the head-fronts of bias- and record heads are parallel. If necessary, bend the arm of the bias head as required.

#### Height Adjustment

Set the tape recorder in stereo record mode, and unscrew the locking screw (H), see fig. 2.7, about 1/2 turn.

Connect an AC voltmeter across each one of the halves of the record head. Move the bias head up or down by means of adjustment screw (M) for the highest possible reading on the voltmeter. Check that the tape runs freely in the groove in front of the bias head, and that there is sufficient clearance between the bias head and the mounting plate for the record head. If necessary, raise the bias head slightly. The height position of the bias head is not critical.

#### Horizontal Adjustment

Connect an AC voltmeter across each half of the record head and set the recorder for stereo recording. Insert a screwdriver in groove (I), see fig. 2.7 and fig. 3.4, and pull the bias head to the right.

Then pull the bias head carefully by means of the screwdriver towards the left hand side. Induced voltage (bias) in the record head increases to a maximum.

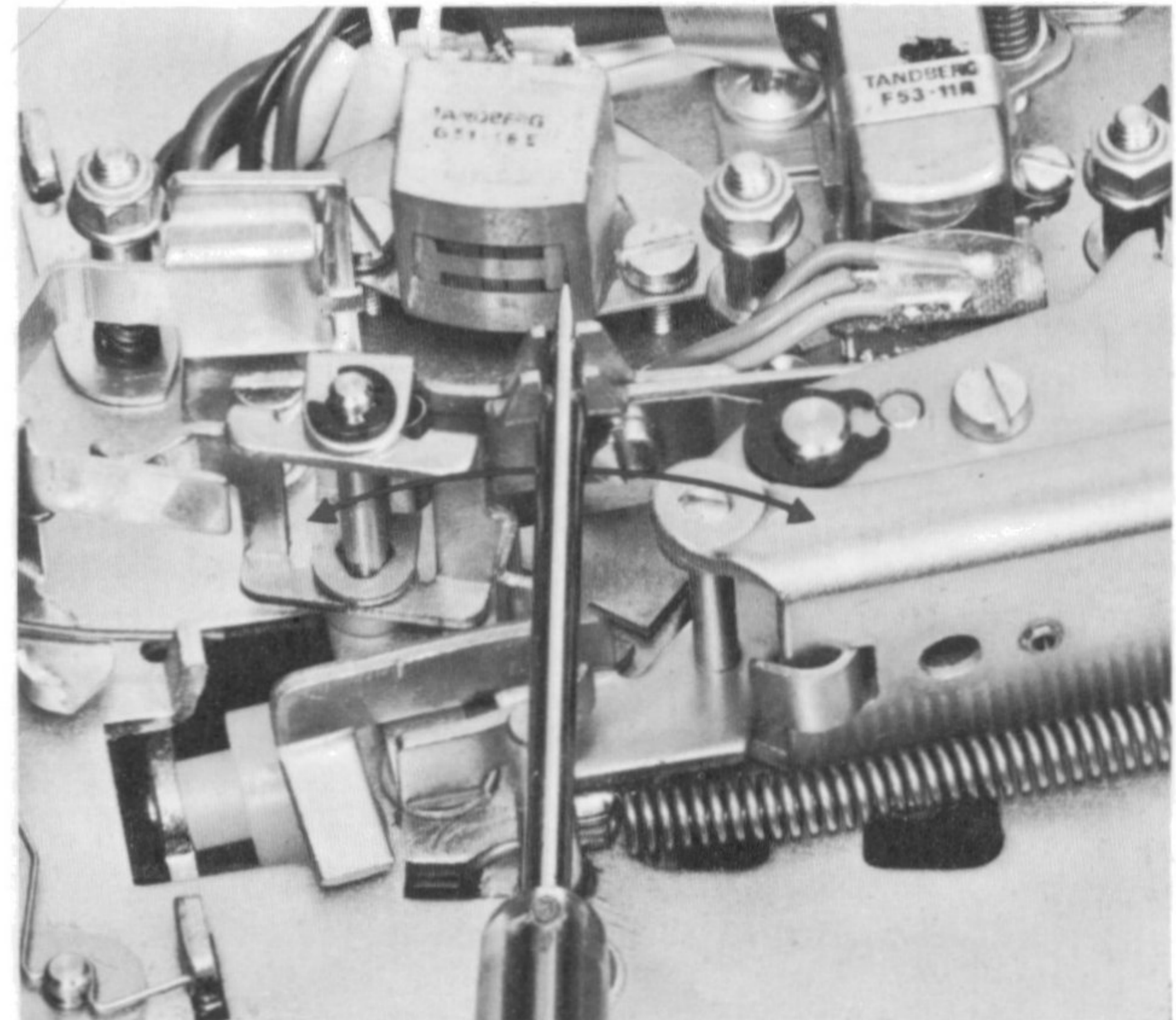

Fig. 3.4. Bias head horizontal adjustment.

Continue pulling the head towards left side until the induced voltage in the record head is reduced by 10–15% below maximum. When the position has been found, tighten the screw (H) while maintaining correct horizontal position of the head. Then recheck the output voltage. If a noticeable change has occurred, the horizontal procedure has to be repeated.

### 3.2.4 Erase Head

#### Height Adjustment

By visual inspection, check that approx. 0.25 mm (0.01") of the upper half of the erase head is visible above the tape, see fig. 3.5. Insert Tandberg test tape No. 9 and record on channel R (track 3 a 400 Hz signal at 7½ ips well above normal recording level. Dip the tape in a solution of fine grained iron oxide powder and alcohol (Magna See). Check that the recorded track is positioned in centre of the erased track.

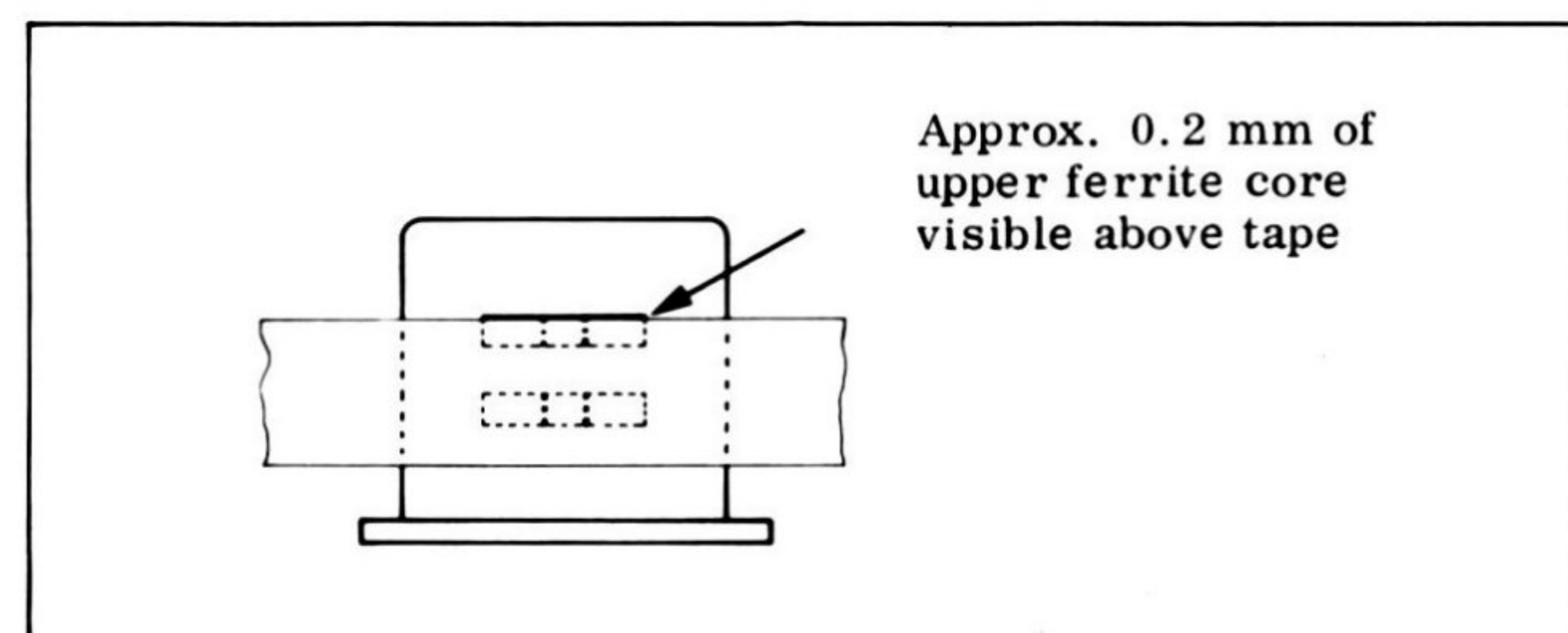
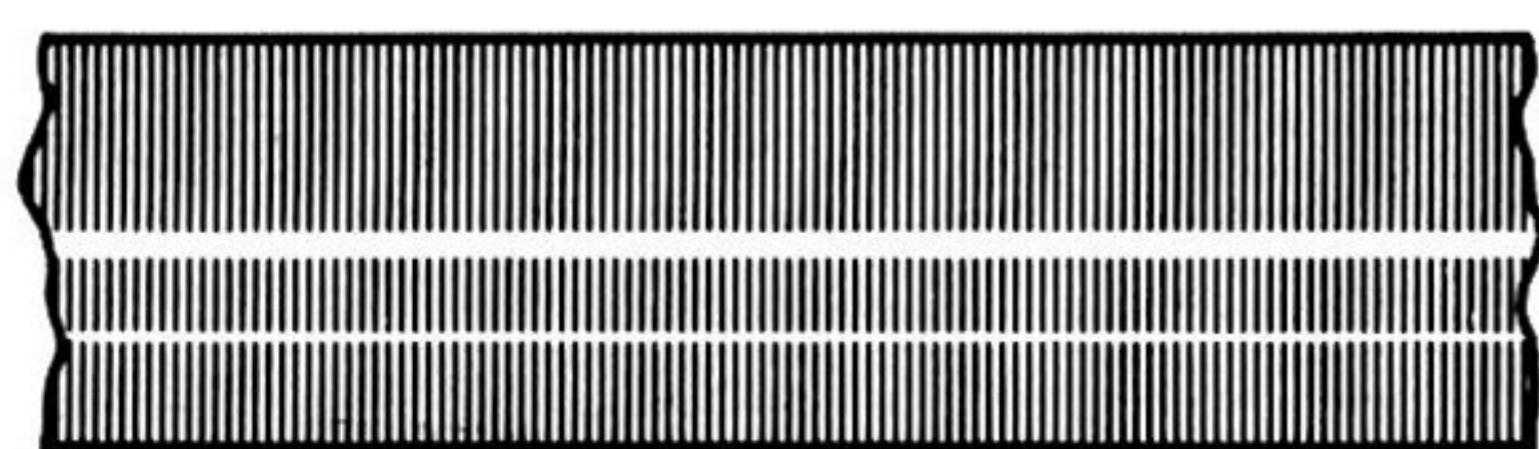
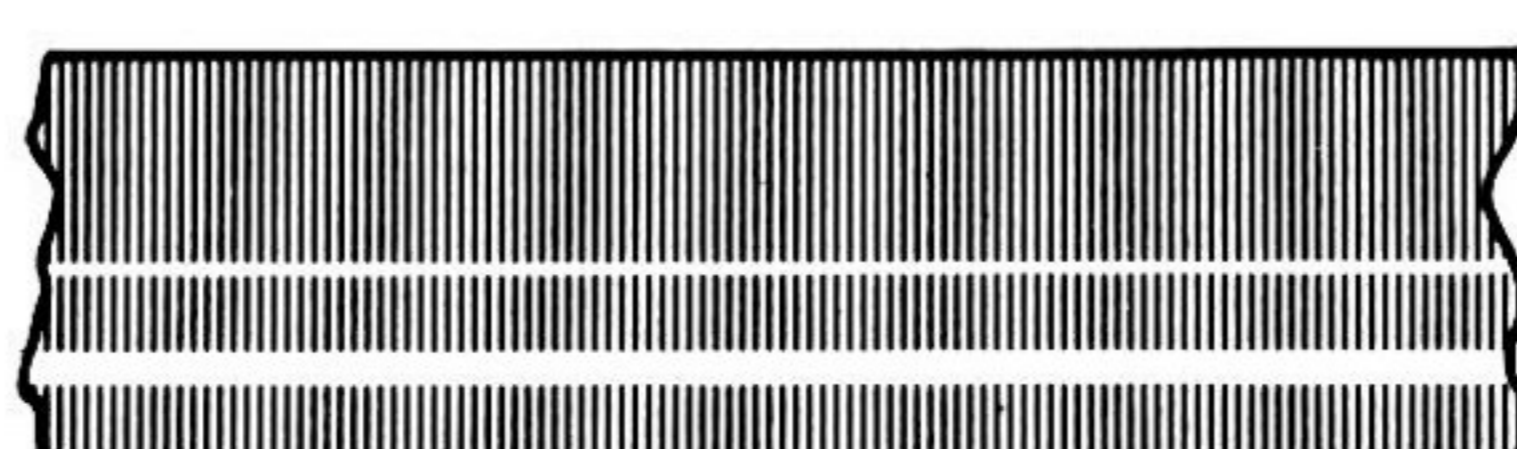

Fig. 3.5. Four-track erase head, coarse height adjustment.

Too high.



Too low.



Correct.

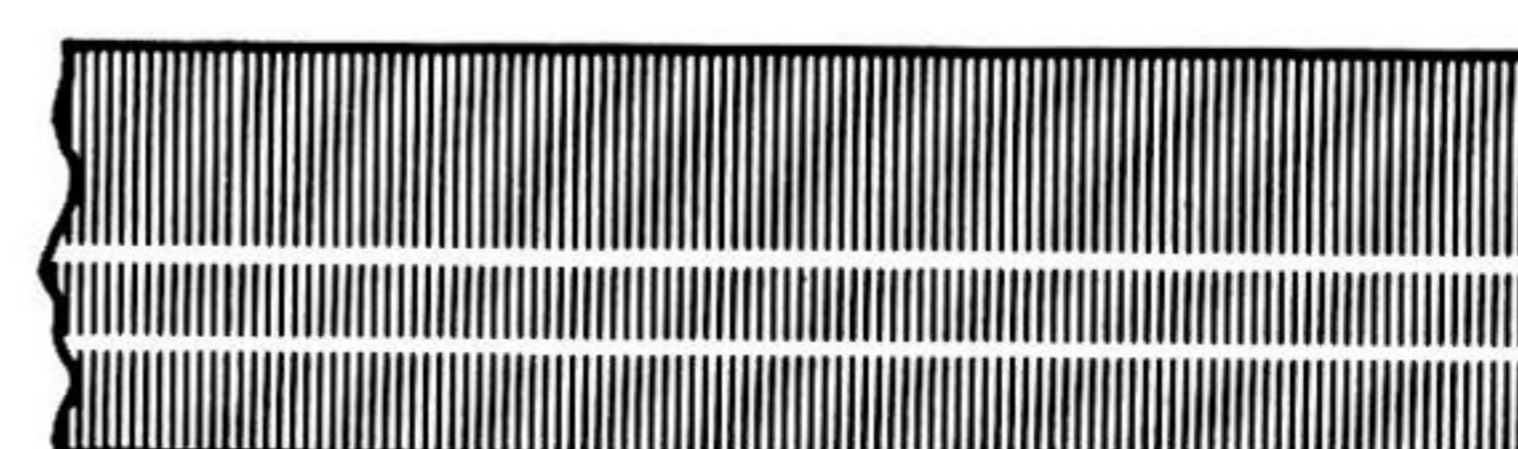

Fig. 3.6. Track measurement, four-track erase head.

Make sure that no parts of the adjacent tracks are erased, see fig. 3.6. If necessary, adjust the height of the erase head by means of screws (K) and (L), see fig. 2.7, and repeat the above check.

#### **Azimuth Adjustment**

Check that the head front of the erase head is perpendicular to the mounting plate. If necessary, adjust azimuth position by means of the screws (K), see fig. 2.7. This adjustment is not critical.

### **3.2.5 Alignment of Hum Shield for Playback Head**

The hum shield for the playback head is so positioned on the pinch roller arm that the shield is right in front of the head during playback.

Set the recorder for stereo playback, both SOURCE/TAPE buttons in positions TAPE, without tape in the tape path. Put a piece of paper between the photoelectric end-stop sensor and the light source in order to start the motor. Set the START/STOP knob to START. Connect an AC voltmeter to each one of the RADIO or LINE outputs.

Loosen the screw, see fig. 2.7, holding the shield one quarter turn. Pull the shield as far away from the head as the mounting hole permits. Adjust the shield sideways to obtain minimum reading on both voltmeters, or best possible compromise.

The hum voltage should not exceed 1 mV.

When the adjustment is completed, tighten the screw and seal with laquer.

### **3.3 HEAD ALIGNMENT ON MODEL 3321X and 3421X — TWO TRACK**

The alignments specified in paragraph 3.2 are valid for the models 3321X and 3421X with the exception of paragraph 3.2.1 Playback Head Height Adjustment, which is superseded by 3.4.1, and paragraph 3.2.2 Record Head Height Adjustment by Visual Inspection, which is superseded by 3.4.2.

## **3.4 HEAD ALIGNMENT WITHOUT TANDBERG TEST TAPES MODELS 3341X AND 3441X — FOUR TRACK**

### **3.4.1. Playback Head**

#### **Height Alignment**

The height of the playback head is aligned by the height adjustment screws (A), see fig. 2.7. The upper edge of the tape shall run flush with the upper part of the head lamination for channel L.

#### **Azimuth Alignment**

Set the SOURCE/TAPE buttons to position TAPE. Play back a standard azimuth alignment tape with an AC voltmeter connected to each RADIO or LINE output. Adjust the position of the playback head by the azimuth adjustment screw (B), see fig. 2.7, until maximum reading is obtained on the voltmeters.

### **3.4.2 Record Head**

Follow the instructions given under paragraph 3.2.2.

### **3.4.3 Bias Head**

Follow the instructions given under paragraph 3.2.3.

### **3.4.4 Erase Head**

#### **Height Adjustment**

The height of the erase head is aligned by the height adjustment screws (K and L), see fig. 2.7. Approx. 0.25 mm (10 mils) of the ferrite core for the upper track of the erase head should be visible above the tape, see fig. 3.5.

## **3.5 MODELS 3321X AND 3421X — TWO TRACK**

The alignments specified in paragraph 3.4 are valid for model 3321X and 3421X with the exception of paragraph 3.4.2 which is superseded by 3.2.2. Paragraph 3.2.2 Record head adjustment by visual inspection is superseded by 3.7.1. Paragraph 3.4.4 Erase head height adjustment is superseded by 3.6.2, Model 3321X and 3421X erase head.

### 3.6 TRACK CONTROL

#### 3.6.1 Models 3341X and 3441X

##### Record Head

Record in stereo a 1.000 Hz signal from a generator well above optimum recording level. Record on tracks 1 and 3 (channels L and R) for approx. 5 seconds. Turn the tape and make a similar recording on tracks 4 and 2 (channels L and R). Cut the tape and dip it into a mixture of fine grained iron oxide powder and alcohol (Magna See solution) to make recording visible. The spaces between the recorded tracks should be distributed equidistant across the tape, see fig. 3.3. If necessary, readjust the height position and recheck the azimuth alignment.

##### Erase Head

Insert a full-track prerecorded tape, and record in mono on track 3 (channel R) a 1.000 Hz signal at level well above normal. Cut the tape and dip it into the Magna See solution. Check that the prerecorded track is in the centre of the erased area, see fig. 3.6. Adjust the vertical position of the erase head if necessary.

##### Playback Head

Record a 1.000 Hz signal on track 1 (channel L) and a 500 Hz signal on track 3 (channel R) well above normal recording level. Set both SOURCE/TAPE buttons to position TAPE. Turn the tape around and play back track 2 (channel R). No signal should be heard. Raise the playback head if the 1.000 Hz signal is heard. Lower the playback head if the 500 Hz signal is heard. Recheck the azimuth position.

#### 3.6.2 Models 3321X and 3421X

##### Erase Head

The height of the erase head is aligned by the adjustment screws (K and L), see fig. 2.7. Adjust until equal parts of the head lamination is visible above and below the tape, see fig. 3.7.

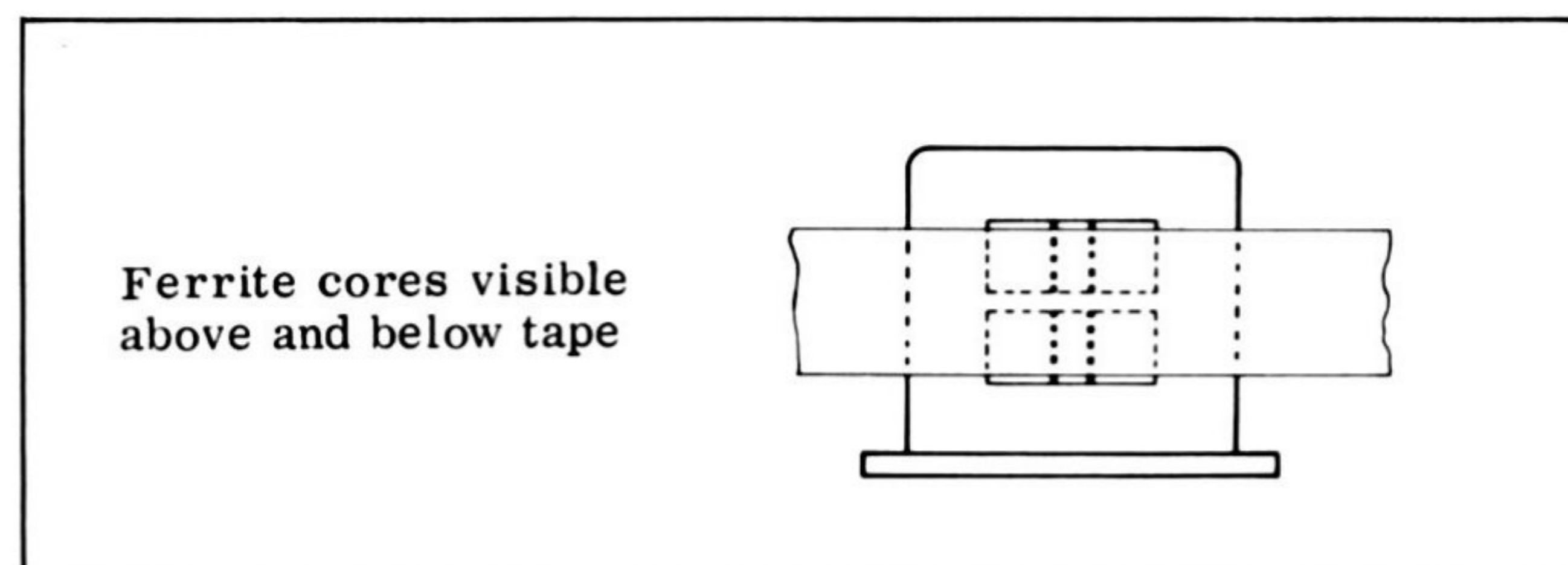

Fig. 3.7. Two-track erase head, coarse height adjustment.

##### Record Head

The height of the record head is aligned by the height adjustment screws (C), see fig. 2.7. Record in stereo a 1.000 Hz signal well above normal recording level on a full track prerecorded tape. Dip the tape in Magna See solution and check that the tracks are distributed symmetrically across the tape. If necessary, readjust the erase and the record heads.

##### Playback Head

The height of the playback head is aligned by the height adjustment screws (A), see fig. 2.7. The tape shall run parallel with the upper edge of the lamination for channel L. If necessary readjust the azimuth position.

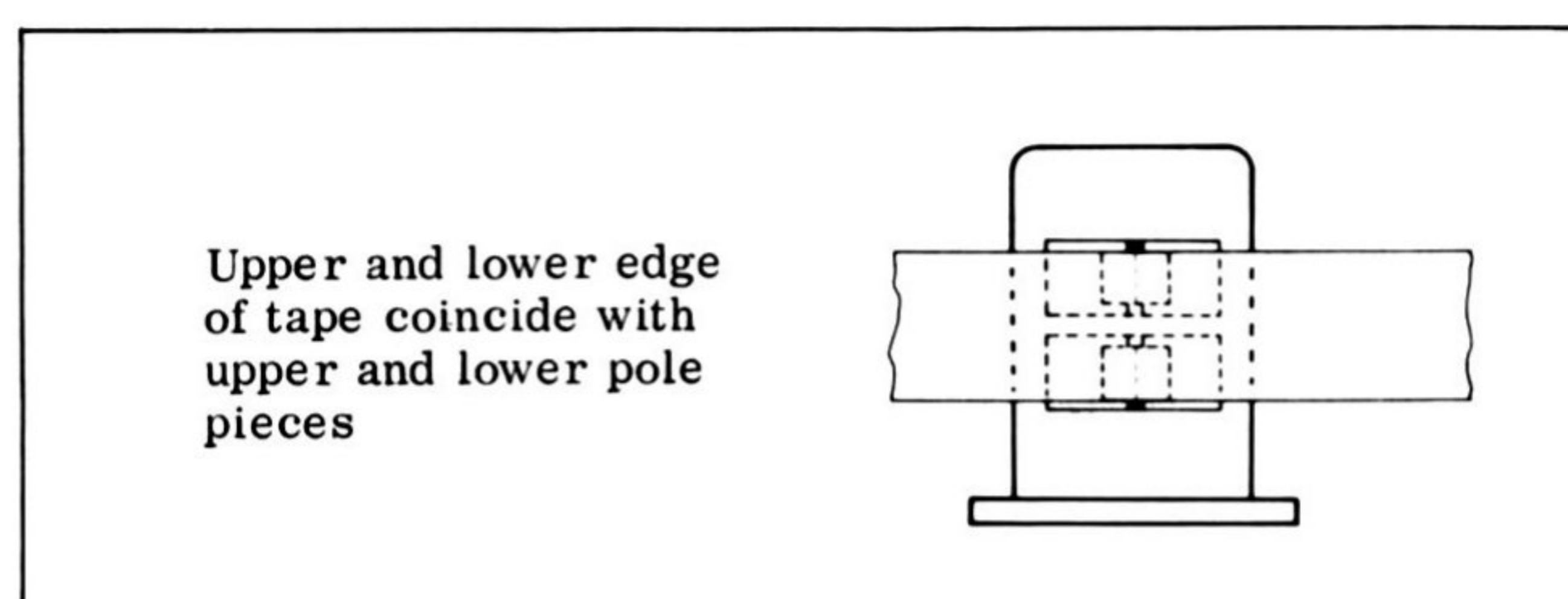
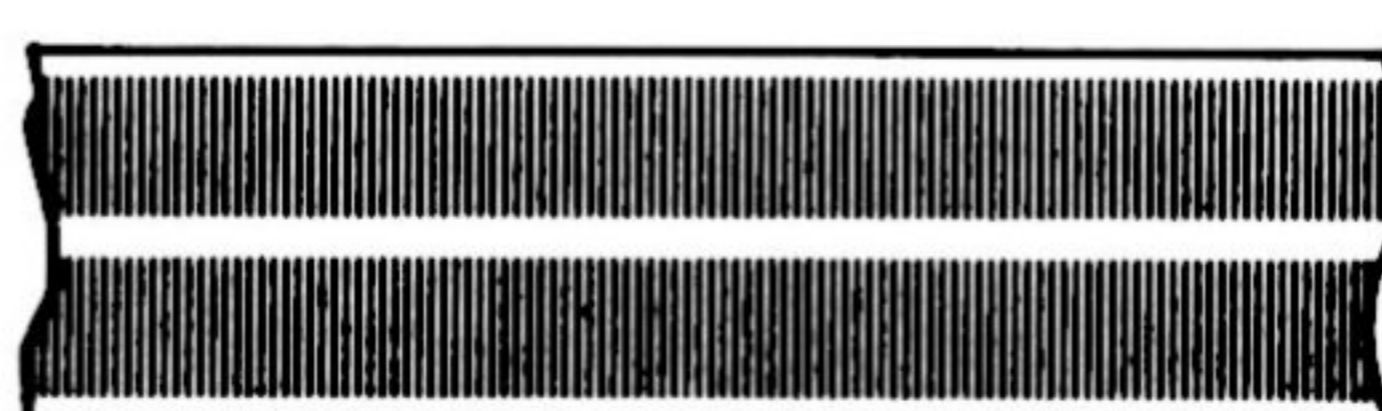

Fig. 3.9. Two-track playback head, coarse height adjustment.

Too high.



Too low.



Correct.

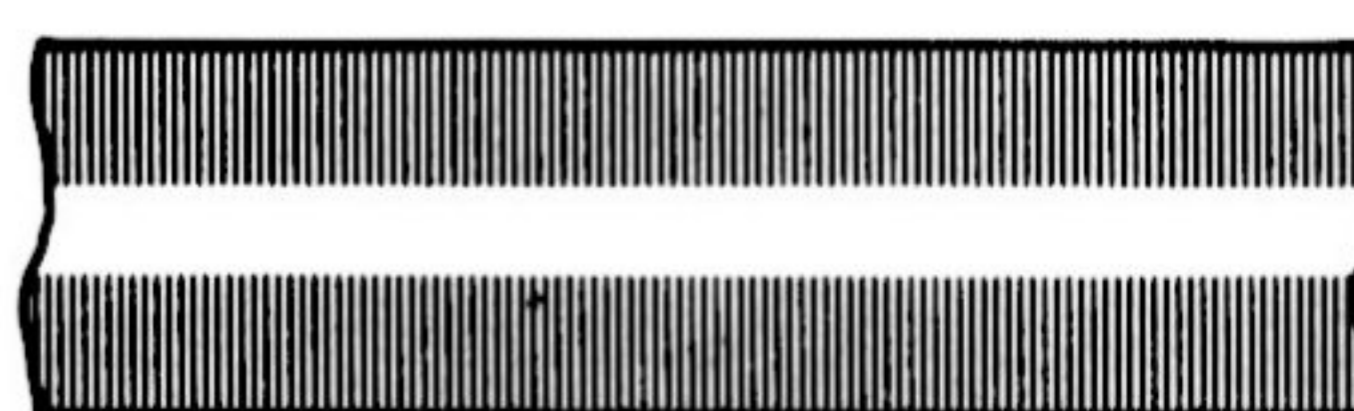

Fig. 3.8. Track measurement, two-track record head.

## 3.7 ADJUSTMENT AND CONTROL OF THE AMPLIFIERS

### 3.7.1 Playback Level Adjustment

Connect an AC voltmeter to each one of the LINE or RADIO outputs, and set the SOURCE/TAPE buttons to position TAPE.

Set the recorder for 7<sup>1</sup>/<sub>2</sub> ips playback of Tandberg test tape No. 4 and adjust R166 (L) and R266 (R) for 1 V reading on the AC voltmeters.

### 3.7.2 Adjustment of Bias Current

Load the recorder with a reel of good quality tape (Low Noise High Output). Connect an AC voltmeter to each one of the LINE or RADIO outputs, and a signal generator to line input terminals. Both SOURCE/TAPE buttons must be in positions TAPE. Set the generator for 1.000 Hz, 0.5 V, and start the recorder in stereo recording.

Adjust the INPUT LEVEL potentiometers to 75 mV deflection on the voltmeters. Adjust R400 to maximum deflection on left channel voltmeter, and R401 to maximum on right channel voltmeter.

**Note:** The two-track model is equipped with individually tuned bias- and erase heads. The values of C400–C403 are labelled on the bias- and erase heads respectively. The capacitances are given in pF. Upper number refers to upper track.

### 3.7.3 Record Level Adjustment

Connect an AC voltmeter to the LINE or RADIO output of each channel, and connect a signal generator to the input of each channel.

Load the recorder with a new tape and record in stereo a 400 Hz signal at 7<sup>1</sup>/<sub>2</sub> ips leaving the SOURCE/TAPE buttons in position SOURCE. Adjust the INPUT LEVEL controls for a voltmeter deflection of 1 V at both outputs.

Depress SOURCE/TAPE buttons and adjust R112 (L) and R212 (R) to 1.25 V reading on the voltmeter. Adjust R127 to 0 dB reading on left record level indicator and R237 for the same reading on the right indicator.

### 3.7.4 Record/Playback Curves

See paragraph 3.7.11 for control of record/playback curves.

### 3.7.5 Distortion

Connect a signal generator, 400 Hz 0.5 V, to RADIO inputs and a distortion meter to the LINE or RADIO outputs. Both SOURCE/TAPE buttons must be in position TAPE. Start the recorder in stereo recording. Adjust with INPUT LEVEL potentiometers to 0 dB deflection on the record level indicators.

Check distortion to be less than 3 %. If the distortion exceeds 3 %, readjust recording level and indicator, see paragraph 3.7.3.

### 3.7.6 Control of Playback Amplifier Using Test Tape

Connect an AC voltmeter to each one of the LINE or RADIO outputs, and set the SOURCE/TAPE buttons to position TAPE.

Play back Tandberg test tape No. 3. This is a full-track prerecorded tape with the following frequencies: 250 – 10.000 – 5.000 – 1.000 – 50 – 250 Hz recorded at 7<sup>1</sup>/<sub>2</sub> ips. The tape conforms with the N.A.B. standard. The output tolerances are: 10.000 Hz: 0 to +4 dB, 5.000 Hz: –1 to +3 dB. The other frequencies have tolerances ±2 dB. The difference in level between the two channels should be less than 3 dB.

### 3.7.7 Tape Speed Control

#### Using Frequency Meter or Counter

Connect a frequency meter or counter to LINE or RADIO output for channel L, and set the SOURCE/TAPE buttons to position TAPE. Play back at 7<sup>1</sup>/<sub>2</sub> ips tape speed Tandberg test tape No. 11 (1.000 Hz). The difference from correct tape speed is indicated in %. Tolerance: ±1 %.

#### Using Transformer and AC Voltmeter

Connect a transformer 115/0.5 V or 230/0.5 V, 50/60 Hz, and an AC voltmeter to output on channel L as shown in fig. 3.10. Set SOURCE/TAPE L button to position TAPE.

Play back Tandberg test tape No. 10 (mains frequency 50 Hz) or No. 19 (mains frequency 60 Hz) at 7<sup>1</sup>/<sub>2</sub> ips tape speed.

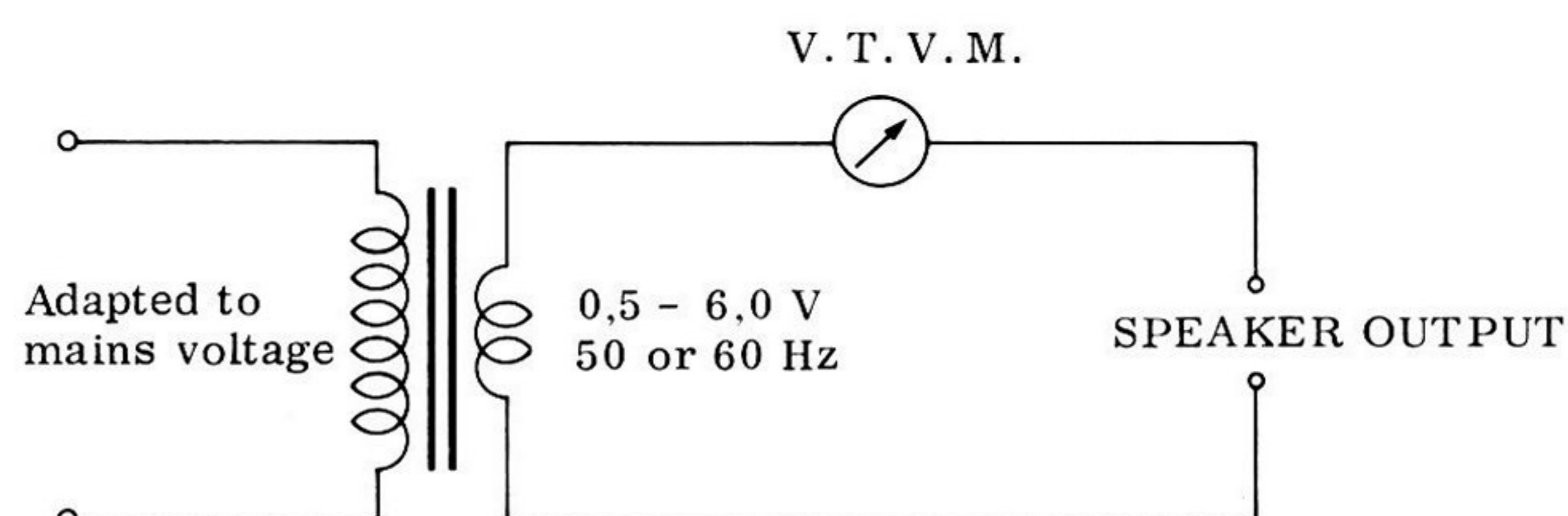

Fig. 3.10. Connections for speed control using transformer and AC voltmeter.



Deviation from correct tape speed will give a beat across the voltmeter.

Clock the time for 10 complete excursions of the meter needle. Read the speed deviation in per cent from the nomogram corresponding to this particular time, see fig. 3.11. Brake left hand reel slightly to decide if the tape speed is too high or too low.

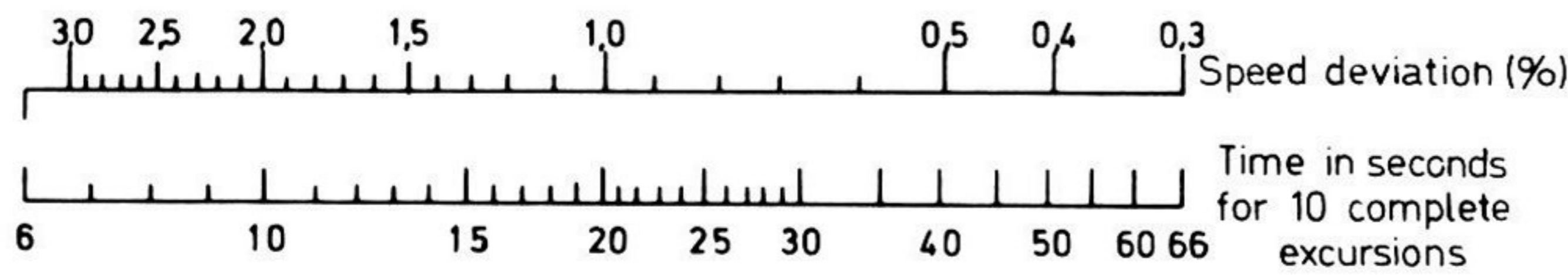

Fig. 3.11. Nomogram for circuit in fig. 3.10.

Increased deviation indicates too low tape speed. At  $3\frac{3}{4}$  ips, play Tandberg test tape No. 10b (50 Hz mains frequency). Proceed as for  $7\frac{1}{2}$  ips to find speed accuracy. Speed tolerance:  $\pm 1\%$ .

#### Using Tape of Known Length

Load the recorder with a 450" (1144 cm) tape and play it back. Time taken for the whole length should be:

- $7\frac{1}{2}$  ips: 60 seconds
- $3\frac{3}{4}$  ips: 120 seconds
- $1\frac{7}{8}$  ips: 240 seconds

Tolerance for all speeds  $\pm 1\%$ .

### 3.7.8 Record/Playback Curves

Connect an AC voltmeter to each of the LINE or RADIO outputs and a signal generator to the RADIO inputs. Set both SOURCE/TAPE buttons to position TAPE and INPUT LEVEL controls to position 3. Start stereo recording in  $3\frac{3}{4}$  ips of a 400 Hz signal 30 dB below normal recording level (0 dB).

Use the output voltmeter readings as reference level. Then record a 16.000 Hz signal at the same level and check that the output voltage is within  $\pm 2$  dB. Perform fine adjustment of record head azimuth position. If the voltage is too high, increase bias current by means of R400 (channel L) and R401 (channel R).

If the voltage is too low, alter the input signal frequency to 1.000 Hz and adjust for maximum output voltage by means of R400 (channel L) and R401 (channel R). Then go back to 400 Hz, establish the reference level, and recheck the output level at 16.000 Hz. When the tolerance at 16.000 Hz has been met, check that the output level at the frequencies between 40–16.000 Hz do not deviate more than  $\pm 2$  dB from reference level. Perform the same check for  $7\frac{1}{2}$  ips at frequencies between 30–22.000 Hz. Finally check for  $1\frac{7}{8}$  ips the frequencies between 40–9.000 Hz.

The output levels of the two channels should not at any frequency differ more than 3 dB.

### 3.7.9 Readjustment of Record/Playback Level

For readjustments of record/playback level, see paragraphs 3.7.1 and 3.7.3.

### 3.7.10 Distortion

For adjustment and control of distortion, see paragraph 3.7.5.

### 3.7.11 Control of Playback and Record Amplifiers

If the specified tolerances for frequency response are exceeded, check the playback and record amplifiers.

#### Playback Amplifier

Insert a 22 ohms resistor in series with playback head and junction 125 (225).

Connect a signal generator in series with a 1 kohm resistor and a 100  $\mu$ F capacitor and playback, see fig. 3.12. Connect also an AC voltmeter to each one of the RADIO or LINE outputs. Set both SOURCE/TAPE buttons to position TAPE. To ensure correct signal response, apply an oscilloscope. Tune the generator to 400 Hz and set the level 20 dB below 1 V i.e. 100 mV. Check the frequency response according to fig. 3.13.

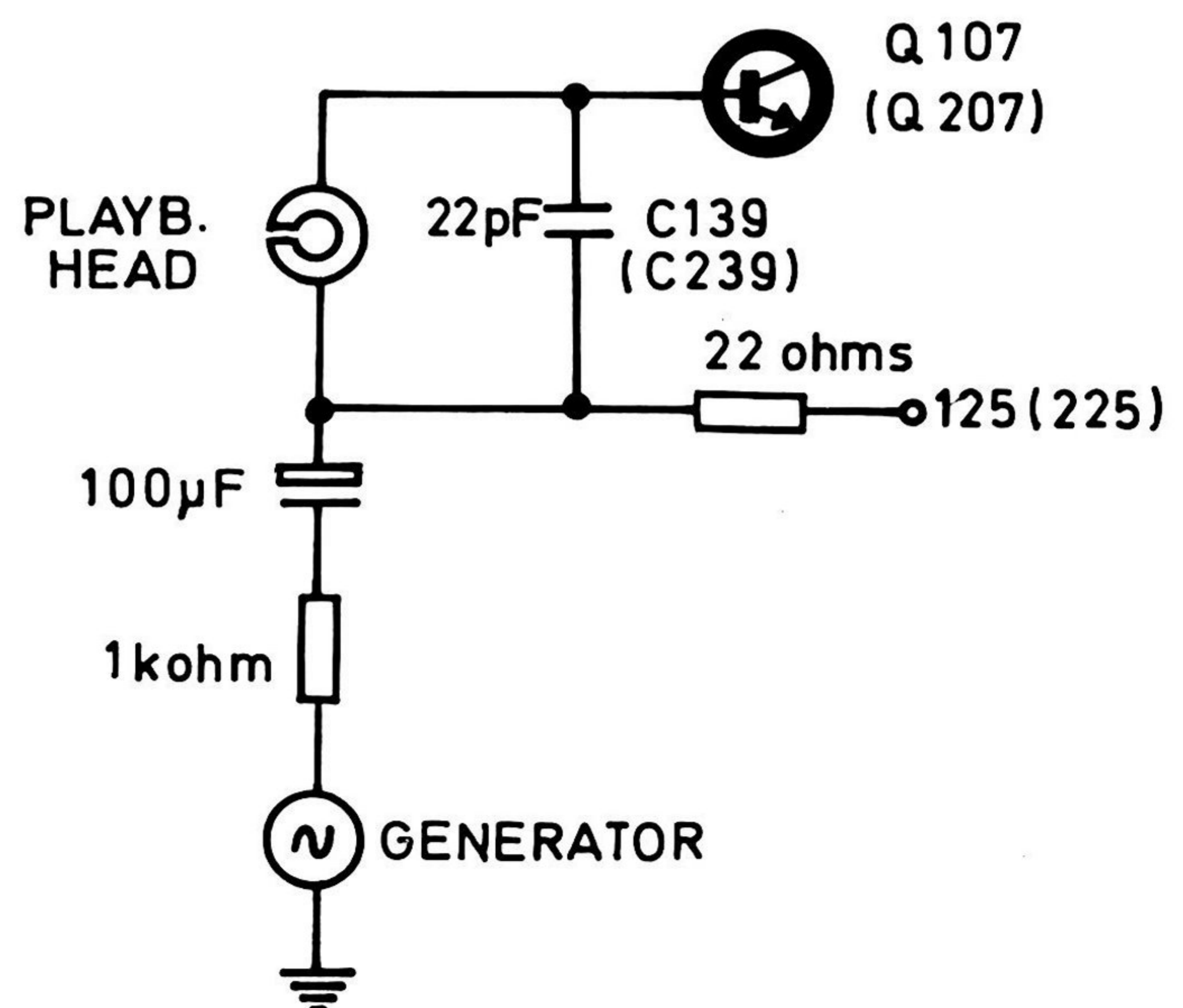

Fig. 3.12. Connections for checking playback curves.

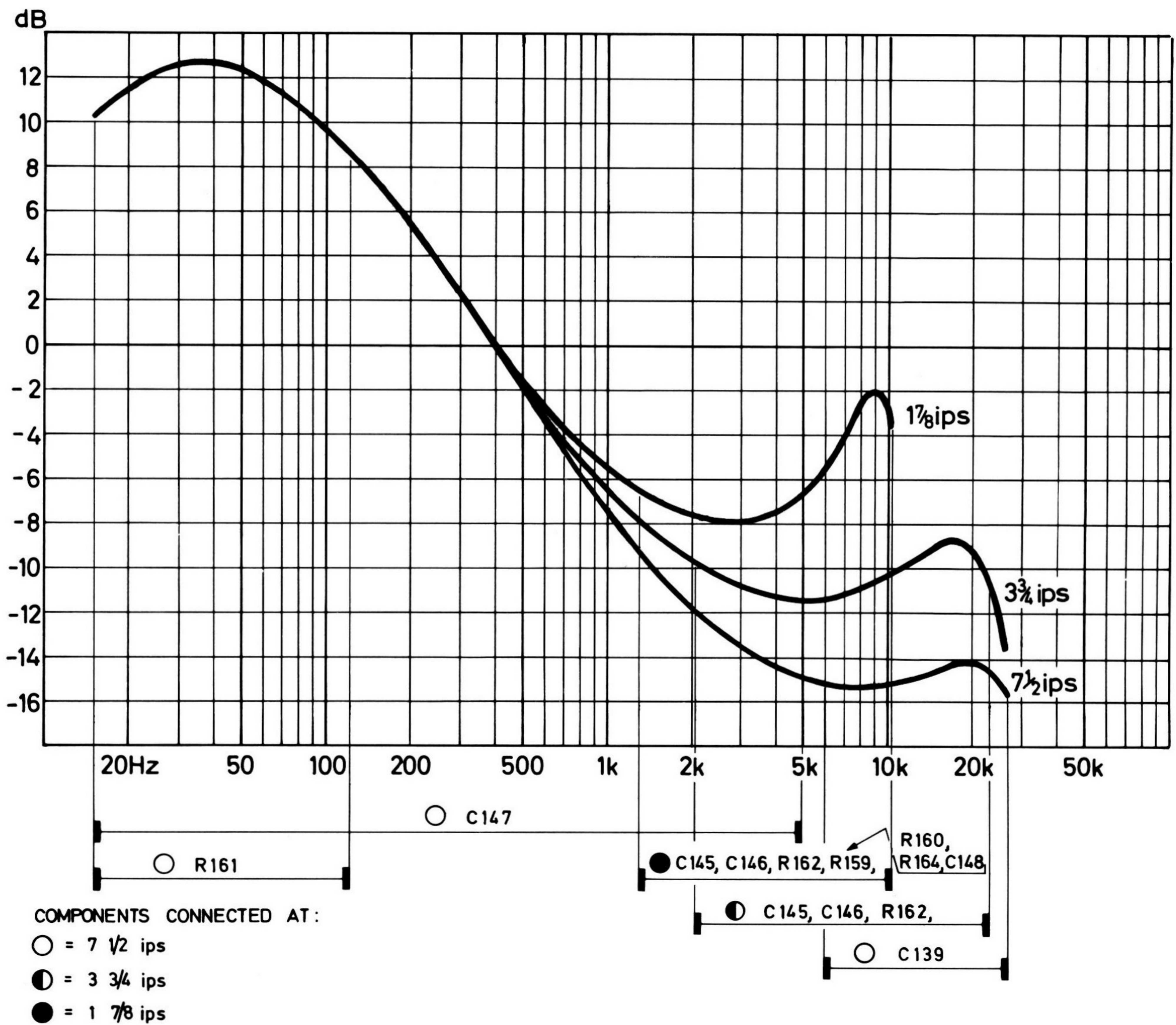

Fig. 3.13. Playback curves.

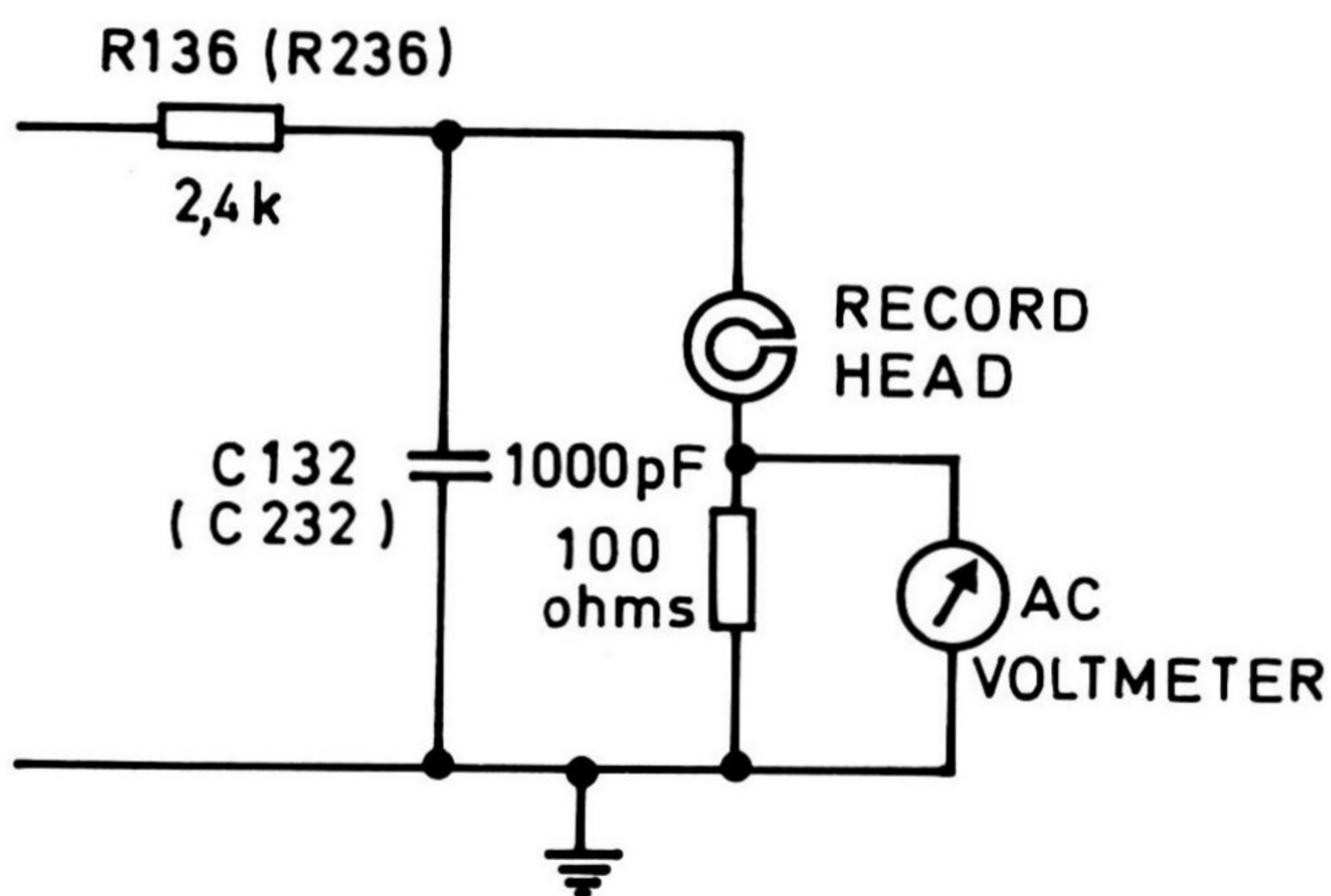

Fig. 3.14. Connections for checking record curves.

### Record Amplifier

Connect an AC voltmeter to a 100 ohms resistor in series with the record head and ground, see fig. 3.14. Connect also a signal generator to RADIO input for each channel. Short-circuit trimming capacitor C502 in the oscillator. Set the tape recorder in stereo recording. Set the level 30 dB below 0 dB indicator deflection, i.e. 10 dB down, by means of INPUT LEVEL controls and 20 dB down on the signal generator. Use the 400 Hz as reference voltmeter deflection. Check the frequency response according to fig. 3.15.

Remove short-circuit of C502.

## 3.8 OUTPUT AMPLIFIERS (3400X)

### 3.8.1 Quiescent Current and Symmetrical Clipping (3400X)

The amplifier symmetry (balance) is determined by fixed components and by DC feedback to stabilize against temperature variations. It will therefore in

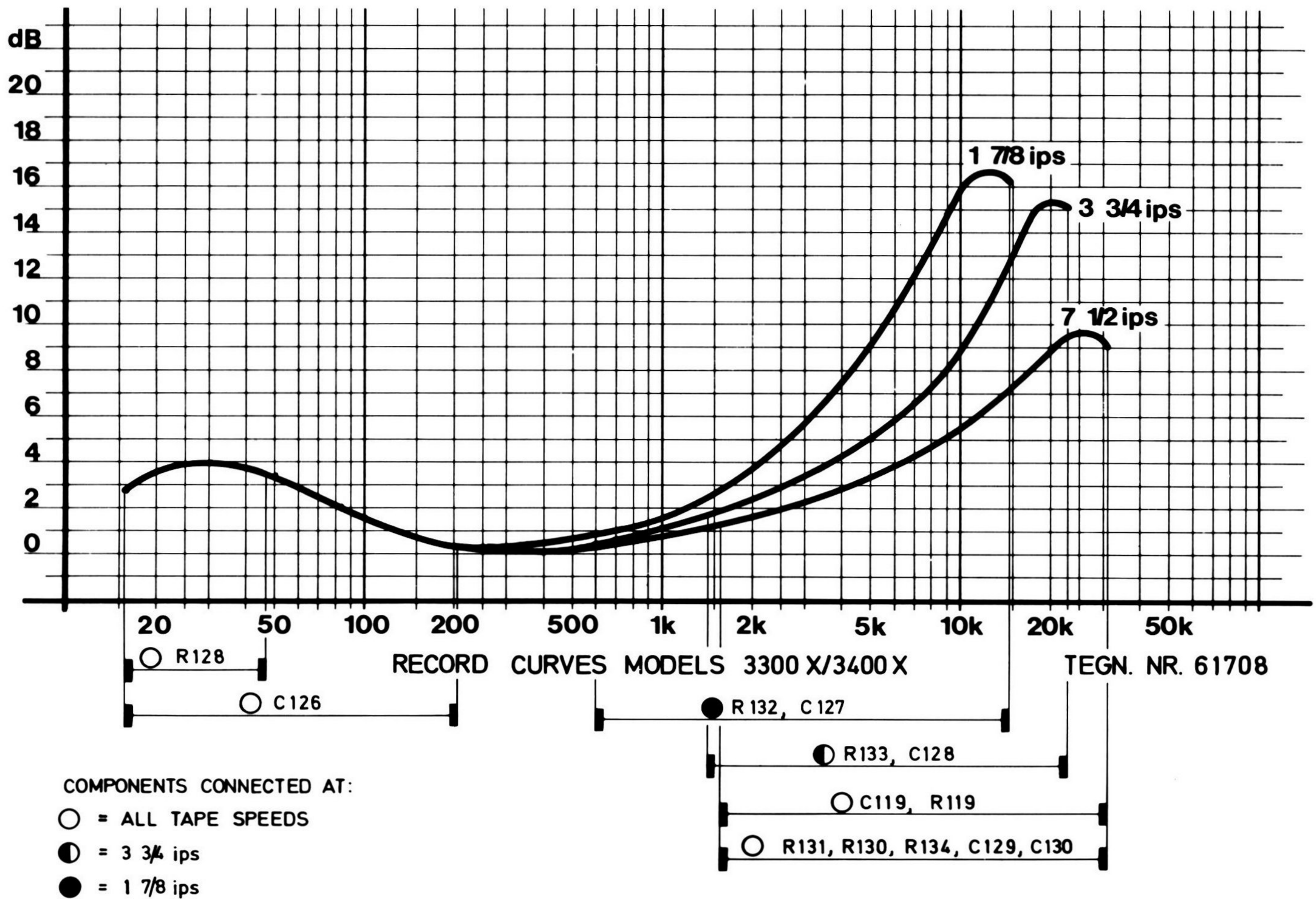

Fig. 3.15. Record curves.

general not be necessary to alter any component values.

The quiescent current is determined by measuring the voltage across emitter resistor R813 and R814 (R913 and R914) using a DC voltmeter.

Adjust by R808 (R908) to a meter reading of approx. 170 mV giving a quiescent current of 30 mA.

The symmetry (balance) is checked with an oscilloscope connected in parallel with a 4 ohms resistor to LOUDSPEAKER outputs position 2, external speaker only. Apply a 400 Hz signal to the amplifier input and increase the input voltage until clipping is observed on the oscilloscope.

The clipping should be symmetrical and should occur at an output voltage of 7.7 V (corresponds to 15 W in 4 ohms).

Another method for checking the balance is to measure at the junction between the emitter resistors R813 and R814 (R913 and R914). When the symmetry is correct, the voltage is half the supply voltage.

The balance can be adjusted by altering the value of the resistors R800 (R900) or R801 (R901). If these resistors have to be altered drastically, it is an indication of some other kind of fault in the amplifier.

### 3.8.2 Checking of Distortion (3400X)

The maximum permissible distortion from the output amplifier at full output power is 1%. To check the distortion, connect a distortion meter and an AC voltmeter in parallel to LOUDSPEAKER output, position 2, for the channel in question. The output must be loaded with a 4 ohms resistor.

Feed a 400 Hz signal to the RADIO input when the recorder is set for amplifier mode.

Increase the level of the input signal so that the output AC voltmeter indicates 7.7 V (15 W in 4 ohms). The distortion should not exceed 1%.

### 3.9 TONE CONTROLS (3400X)

Connect an AC voltmeter to each one of the LOUDSPEAKER outputs, position 2 (external speaker only) and set the recorder in stereo amplifier mode (none of the function selector buttons depressed).

Set the tone controls to centre position and feed a 1.000 Hz signal to RADIO inputs. Set INPUT LEVEL and OUTPUT LEVEL controls to obtain an output level of approximately 200 mV. Use the reading as 0 dB reference and alter the frequency to check that the bass control has  $\pm 15$  dB range at 100 Hz.

Check the treble response to be  $\pm 15$  dB at 10.000 Hz.

## 4.0 MODIFICATIONS

### 4.1 MODIFICATIONS FOR A DIFFERENT LINE VOLTAGE AND FREQUENCY

A label on the motor shows how to wire transformer and motor for 115/130/230/240 V, 50 Hz, operation and 115/230 V, 60 Hz, operation.

When modifying from 50 to 60 Hz operation, or vice versa, the motor pulley has to be changed.

Motor pulley for 50 Hz, ordering No.: 243940C

Motor pulley for 60 Hz, ordering No.: 273787

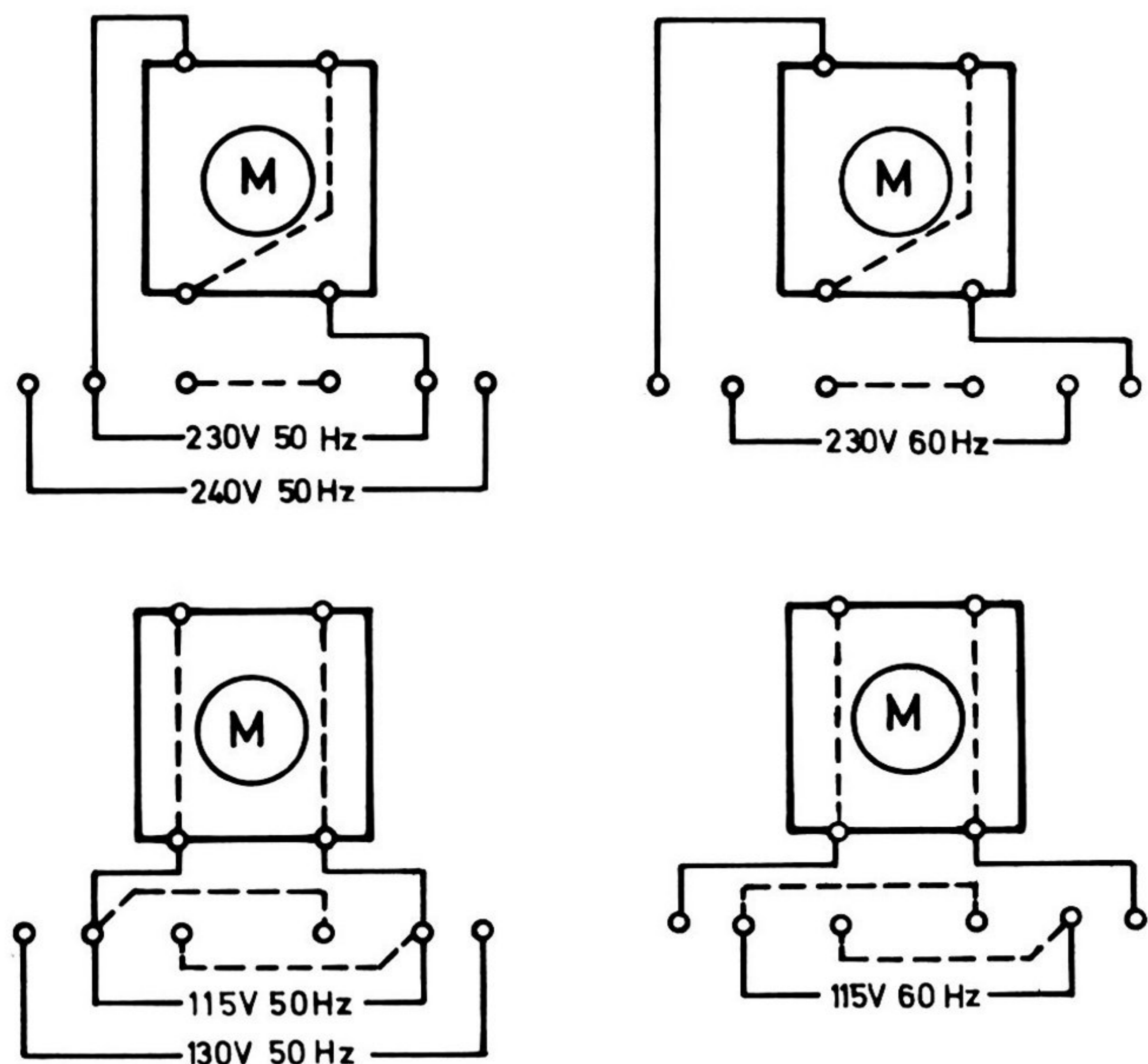

Fig. 4.1. Motor and transformer connections.

### 4.2 MODIFICATION FROM FOUR-TRACK TO TWO-TRACK VERSION

The following components have to be altered when modifying from four-track version to two-track version. Value of total capacitance is labelled on the two-track heads.

Part	Four-track	Two-track
Record head	F53-11R	F82-07R
Playback head	C03-10P	F83-11P
Erase head	D84-11E	D87-20E
Bias head	2079-03B	2958-04B
R136	3.9 kohms	2.4 kohms
R236	3.9 kohms	2.4 kohms
C400	3300 pF	Add capacitance until labelled capacitance is obtained
C401	3300 pF	
C402	250 pF	
C403	250 pF	

When modifications are introduced, adjust heads and amplifiers according to chapter 3.0, Electrical checks and adjustments for the two-track version.

### 4.3 MODIFICATIONS INTRODUCED DURING PRODUCTION OF SERIES 3300X

- **Changing the sensitivity and improving the stability of photo-endstop circuit.**

The photo-endstop circuit has been modified as follows:

R511 has been altered to 10 kohms.

R512 has been removed.

R513 has been altered to 1 kohm.

On units where R511 equals 5.6 kohms, this resistor value shall not be altered.

- **Reducing the effect of line voltage transients and electromagnetic interference.**

On units with serial numbers below 2959700, line voltage transients or electromagnetic interference may cause clicks in the loudspeakers during playback.

This can be prevented by grounding the main amplifier board to chassis according to the figure below. A short wire with a soldering tag is fixed to chassis with a screw, and the other end is soldered to the corner of the foil (ground), see figure 4.2.

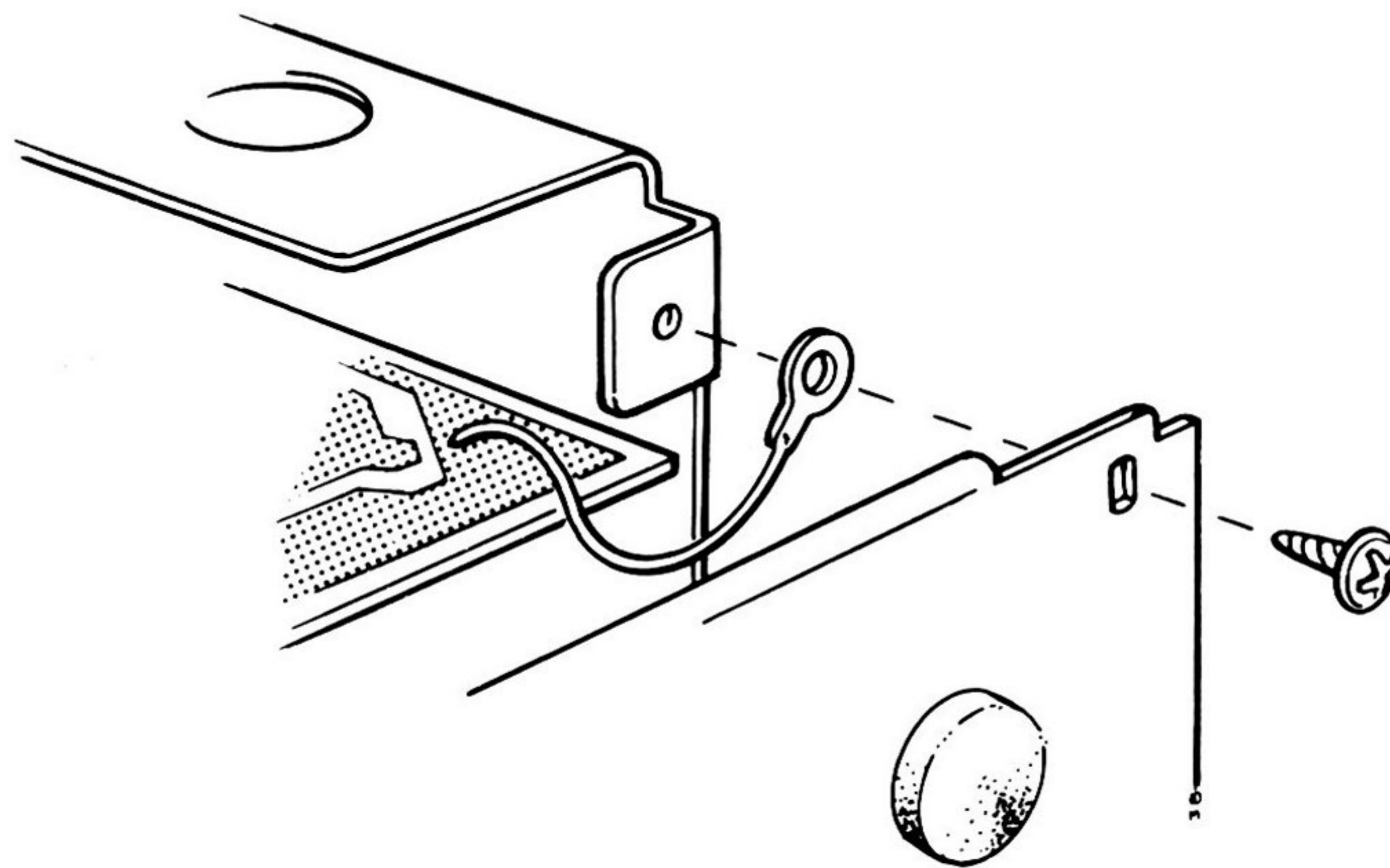

Fig. 4.2. Grounding of main amplifier board.

- **Short-circuiting of the Output when Using Headphones.**

On some units with serial No. below 2953200 the line output transistor can be destroyed when headphones are used. This is caused by the plug which short-circuits the output to ground resulting an immediate charging of capacitor C254. The current in Q211 then exceeds its limit. To avoid this, solder on each channel a 2.7 kohms resistor directly from headphone output socket to ground.

● **Instability when Using Microphones.**

The modification described in step 2 of paragraph 4.3 reduces mains borne r.f. interference. However, in some recorders this modification results in instability when microphones are used and the input level control is turned up too high. The instability has the character of a cracking sound.

This instability can be avoided if a 0.1  $\mu\text{F}$  capacitor is inserted in series with the wire from the phono socket to the chassis. Thus the socket is d.c. isolated from ground while an a.c. connection to ground is retained. The sketch and the details of the circuit diagram explain how the modification is carried out, see fig. 4.3.

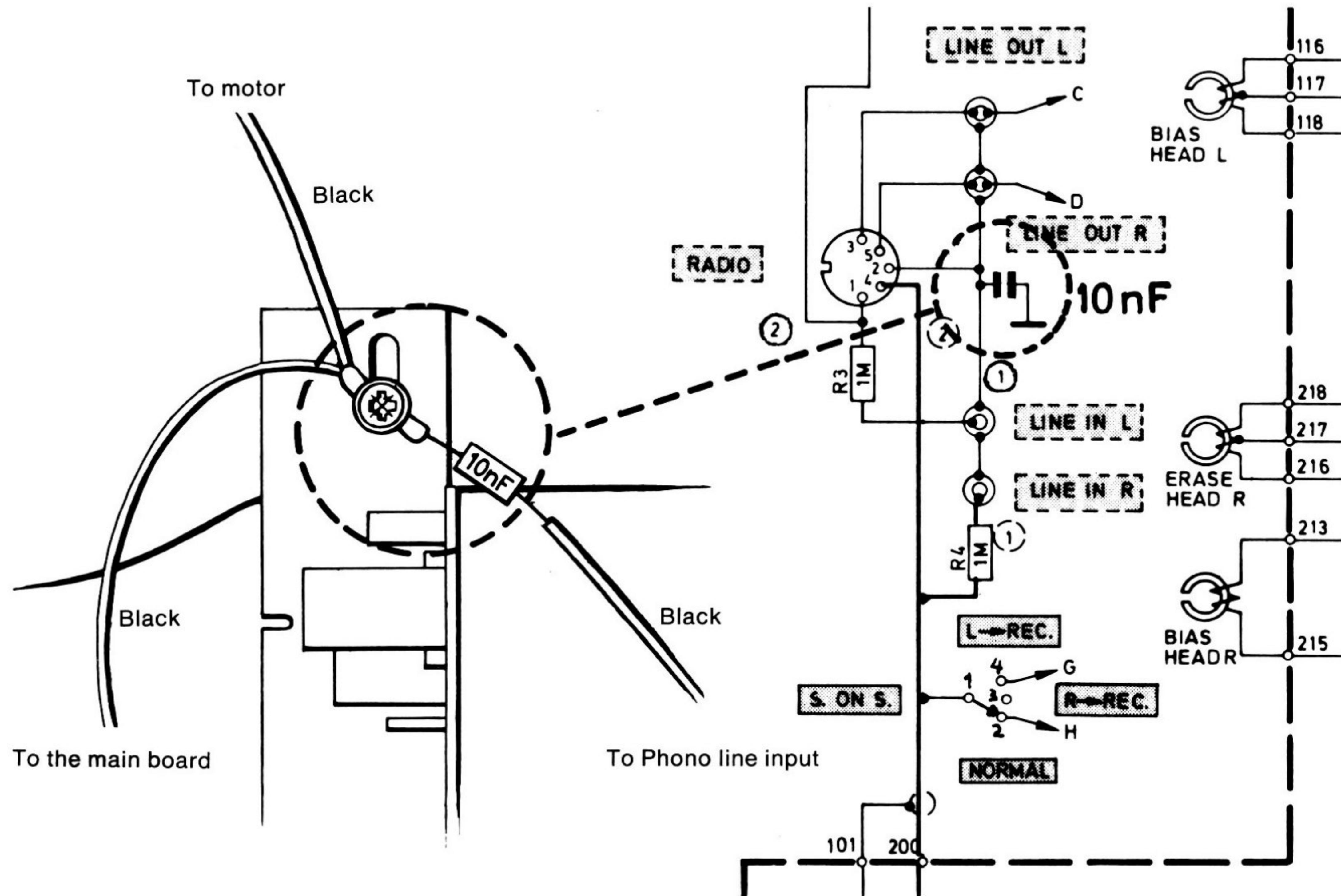
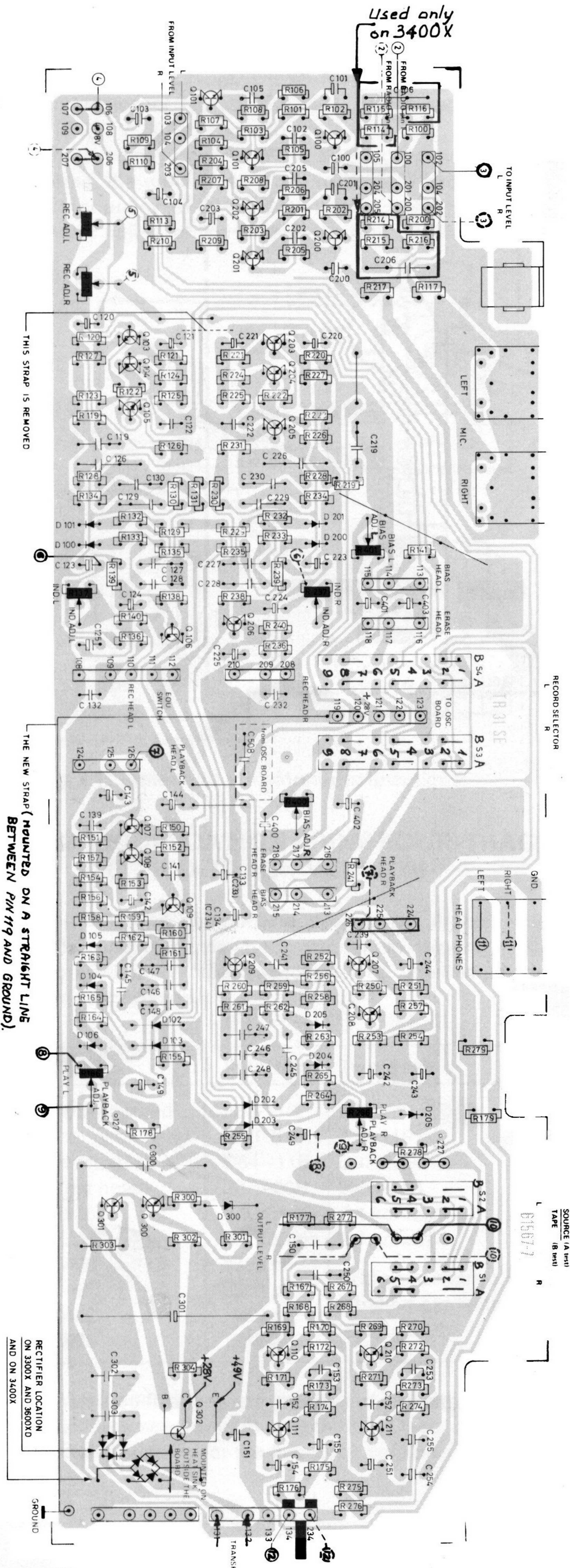

Fig. 4.3

# 5.0 CIRCUIT DIAGRAMS AND PRINTED WIRING BOARDS

## 5.1 SERIES 3300X



### Corrections to Service Manual for tape recorders 3300X and 3400X

The main printed board (61567-4) drawing showing component locations, contained several errors when the service manual was originally issued. These errors have now been corrected and this sheet replaces the main board (61567-7) drawing for Series 3300X and 3400X on pages 20 and 22 respectively.

Board for mic/line amplifiers, record equalizing amplifiers, level indicator amplifiers, playback equalizing amplifiers, booster amplifiers, and DC voltage regulator. Seen from solder side.

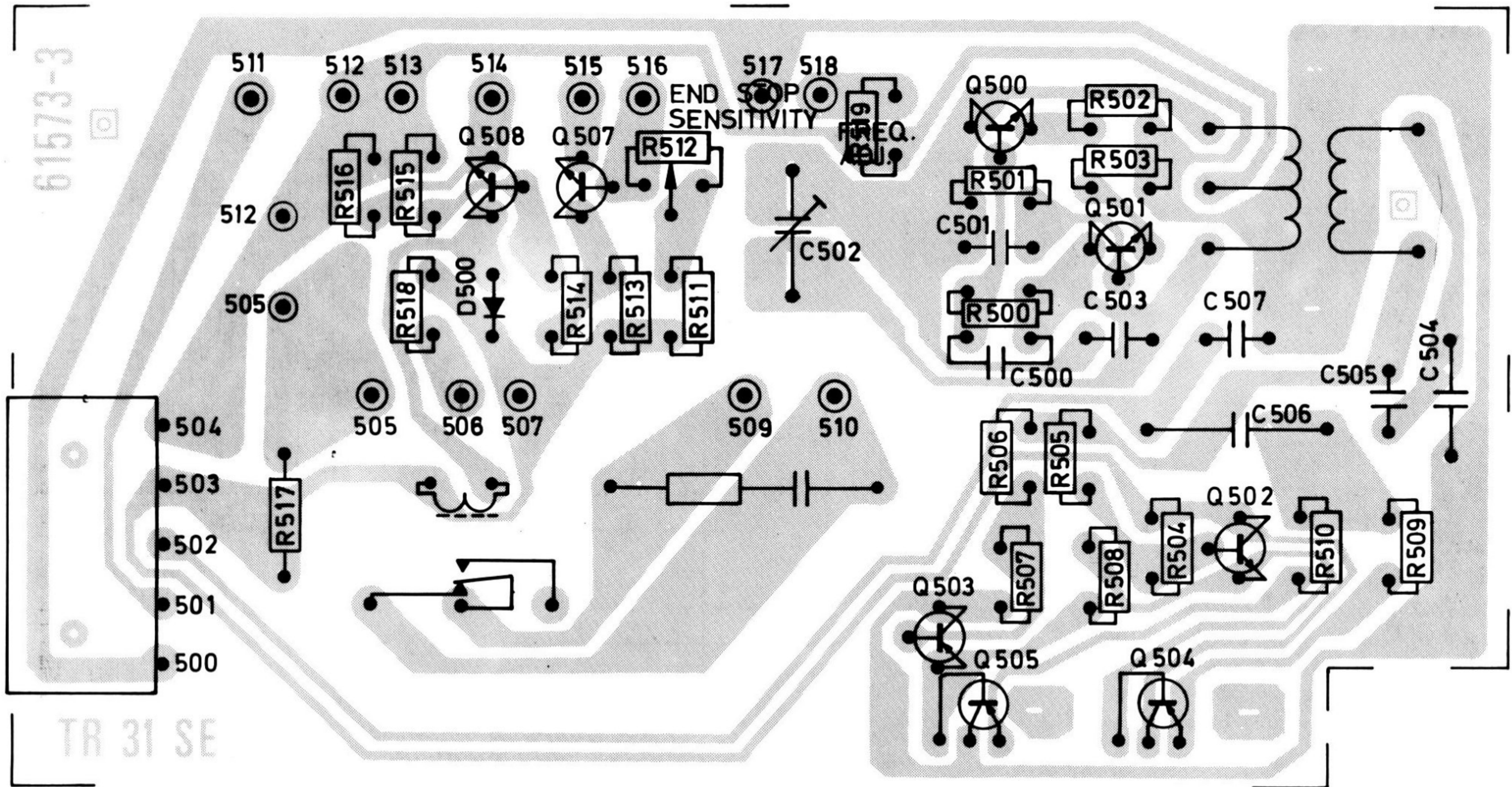

Board for oscillator, bias circuit, and photoelectric end stop circuit. Seen from printed side.

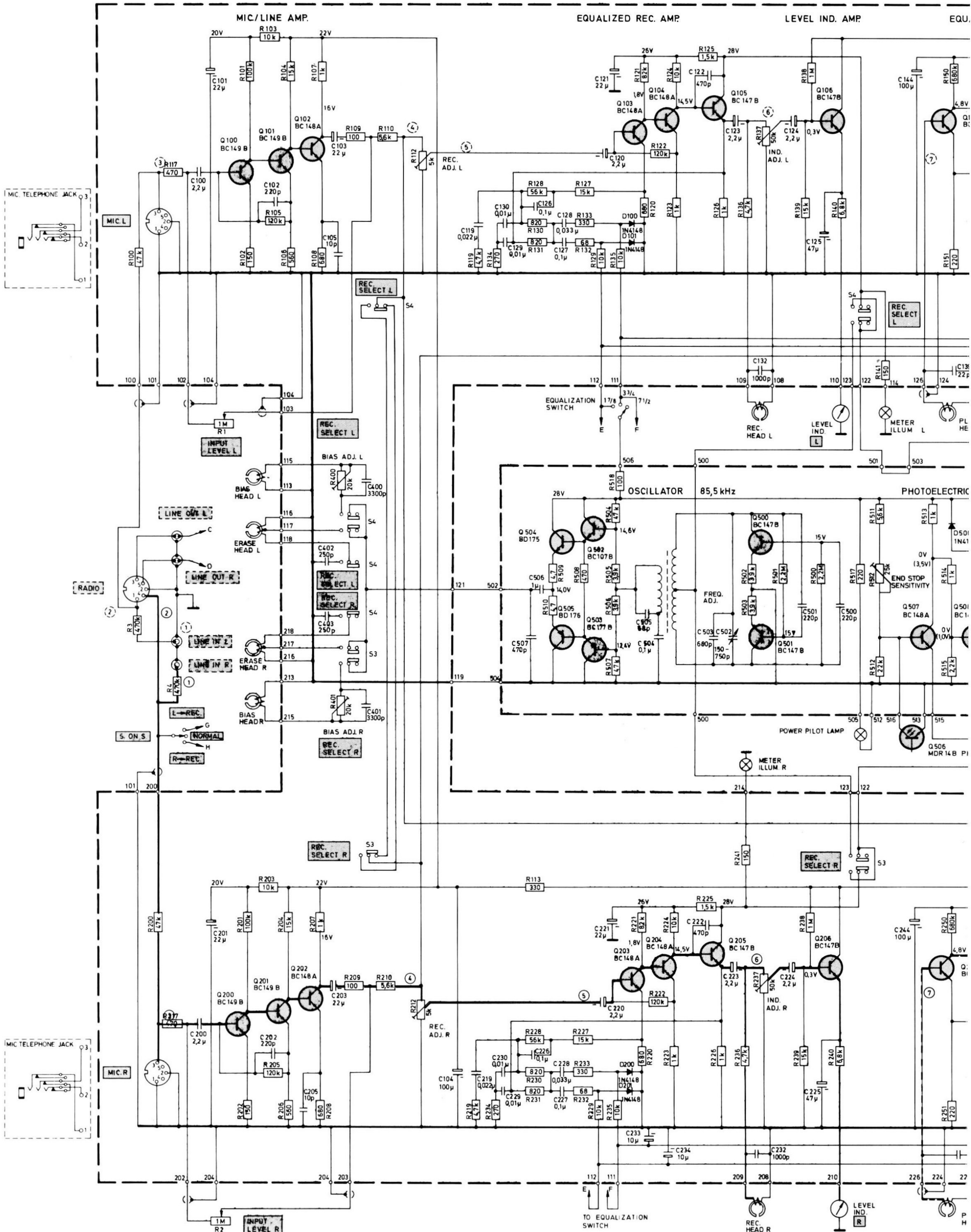



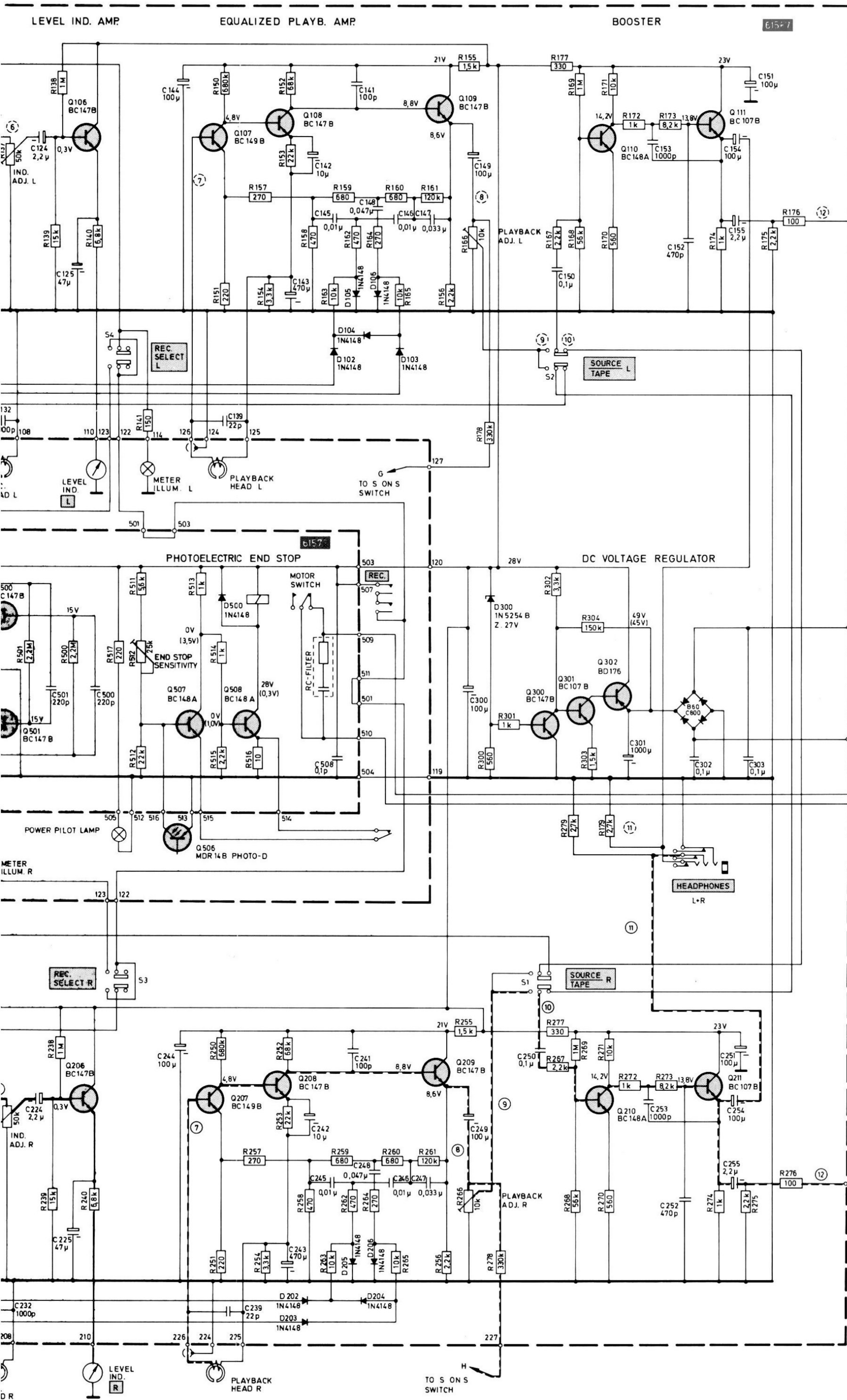

- NOTES
- 5157 = BOARD
  - MIC L = TOP PLATE MARKING
  - LEFT = REAR PANEL MARKING
  - REC. ADJ. = PRESET CONTROL
  - ⑤ ⑥ = TEST POINT
  - o101 = CONNECTION TERMINAL
  - L = UPPER TRACK=LEFT CHANNEL
  - R = LOWER TRACK=RIGHT CHANNEL
  - - - = SIGNAL PATH, PLAYBACK
  - = SIGNAL PATH, RECORD

CAPACITORS INDICATED IN pF UNLESS OTHERWISE SPECIFIED  $\mu = 1000\ 000\ pF$   
 RESISTORS INDICATED IN OHMS UNLESS OTHERWISE SPECIFIED k=1000 OHMS M=1000 000 OHMS

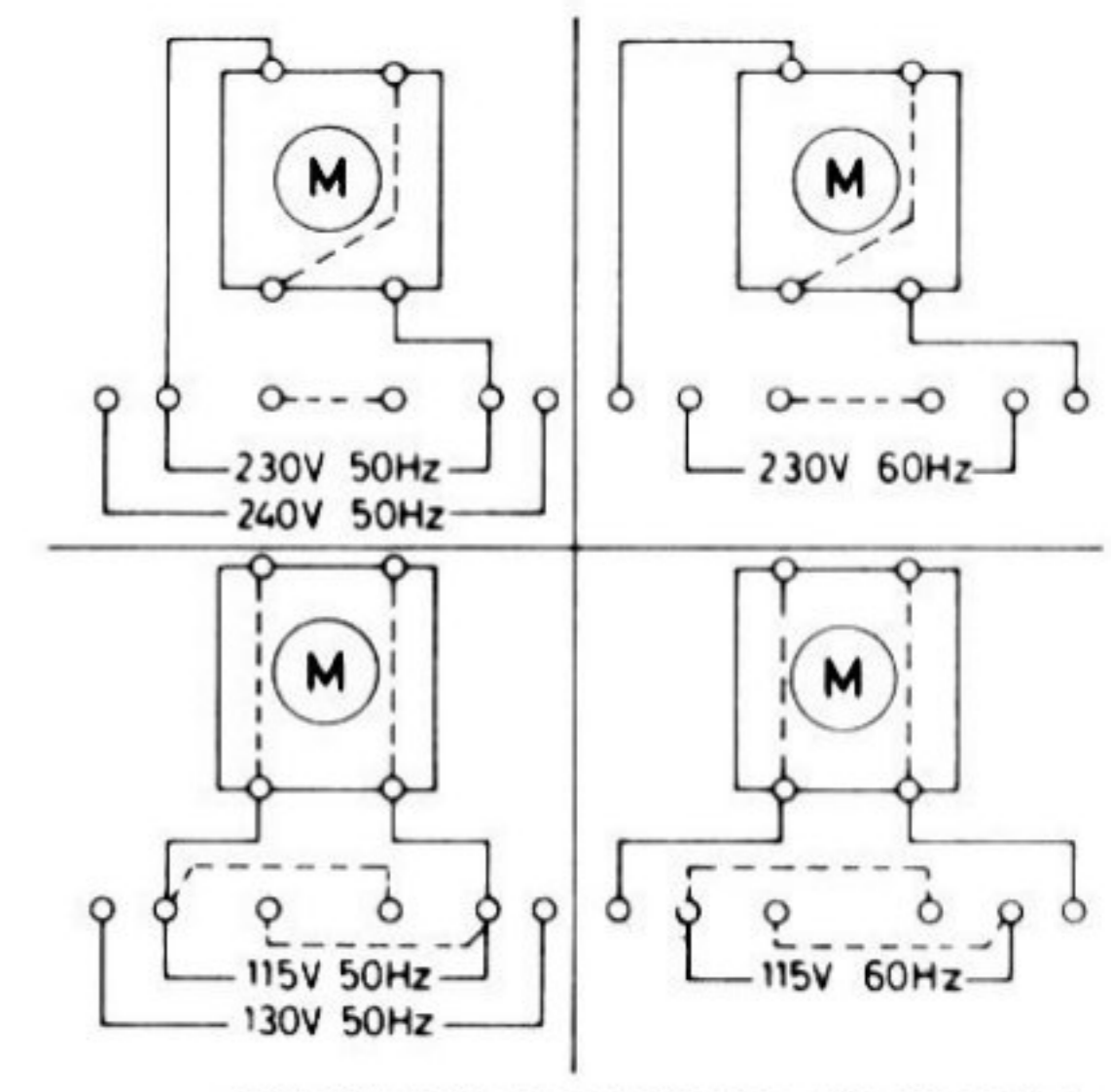

TRANSFORMER AND MOTOR CONNECTIONS

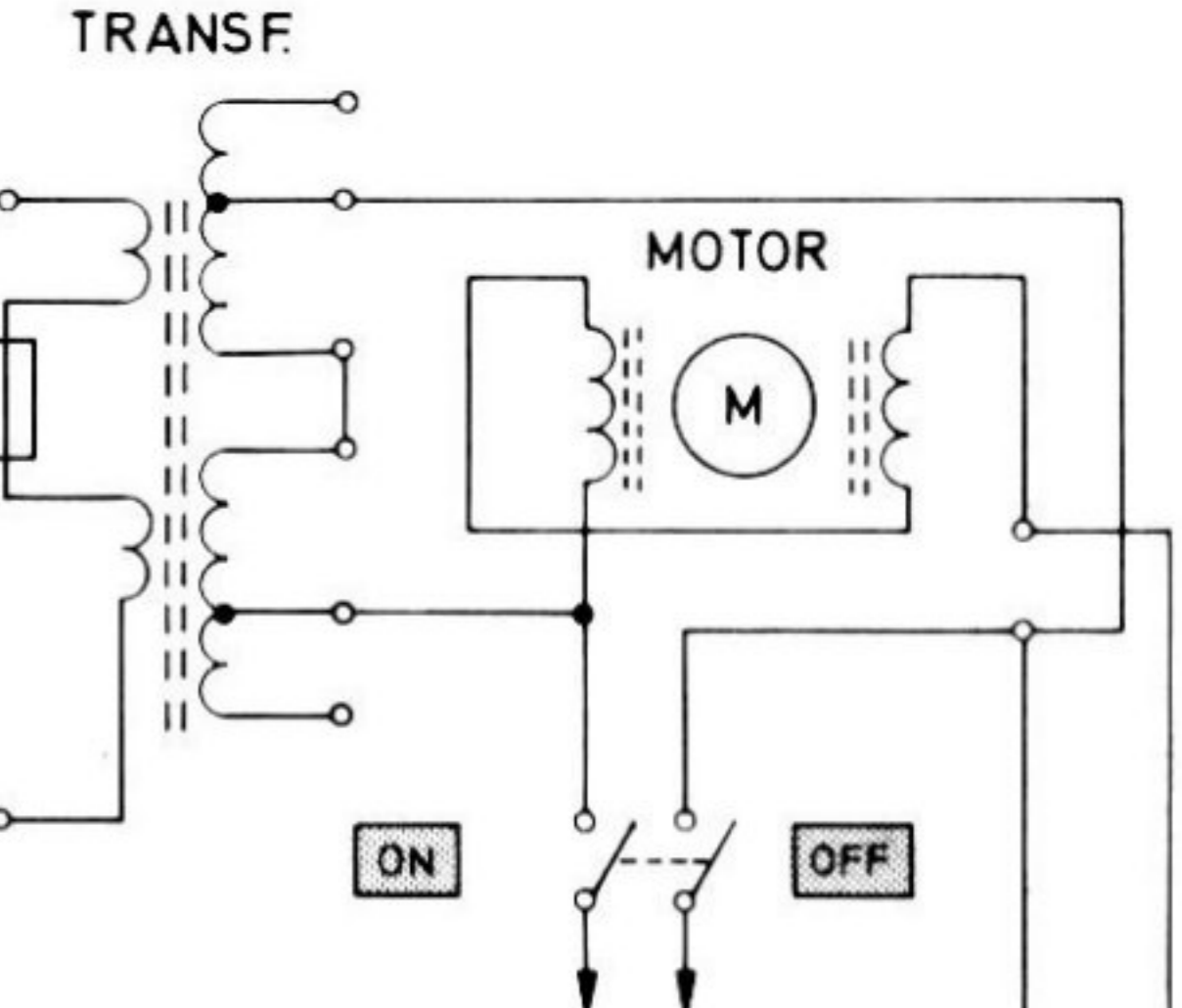

SENSITIVITY AT 400Hz	REC. ADJ.
1 100mV	S1 SOURCE TAP R
2 5mV	S2 SOURCE TAP L
3 50 $\mu$ V 5mV	S3 REC. R
4 70mV	S4 REC. L
5 40mV	
6 1.3V	
7 2mV	
8 350mV	
9 70mV	
10 70mV	
11 1.0V	
12 1.0V	

## 5.2 SERIES 3400X

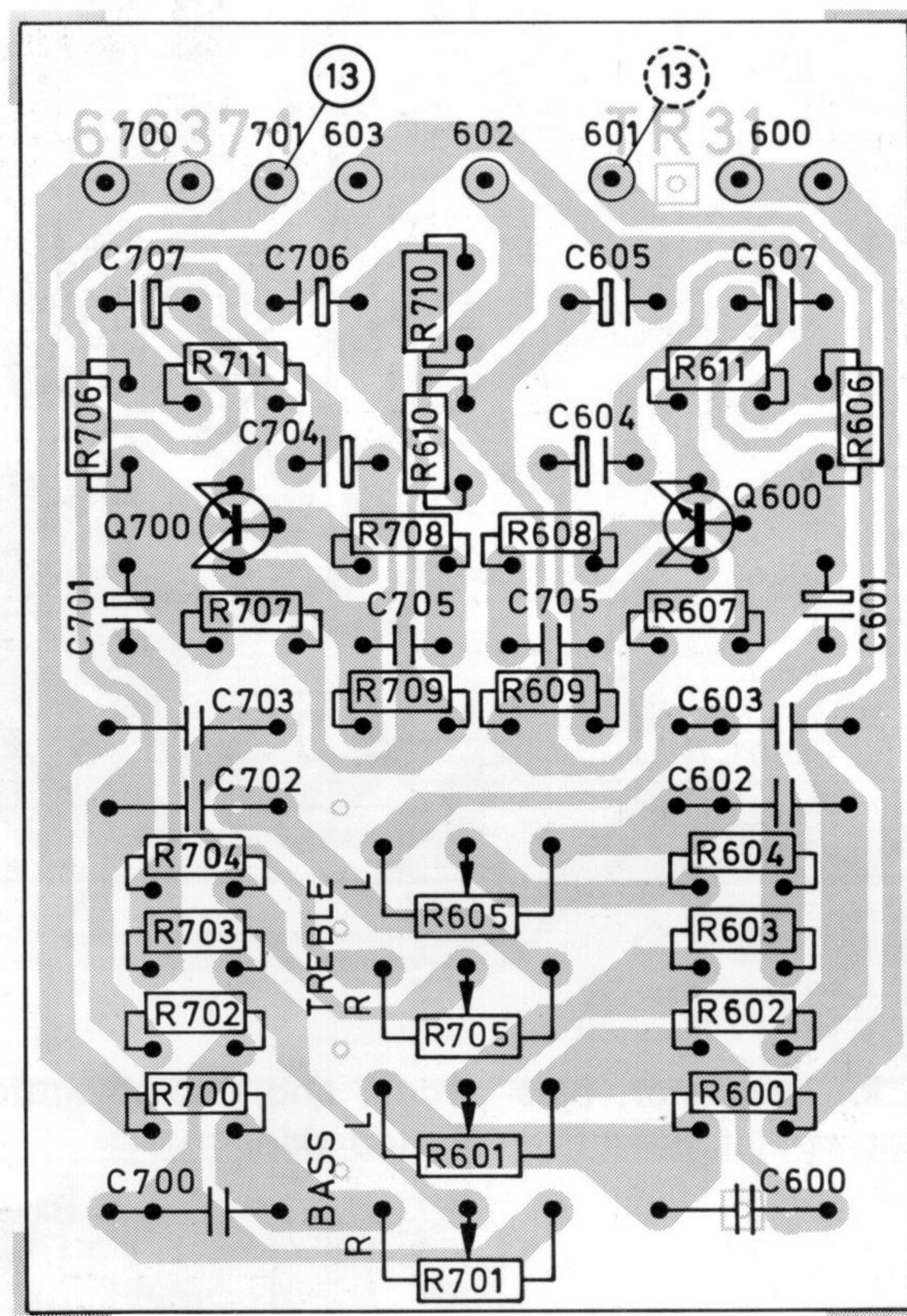
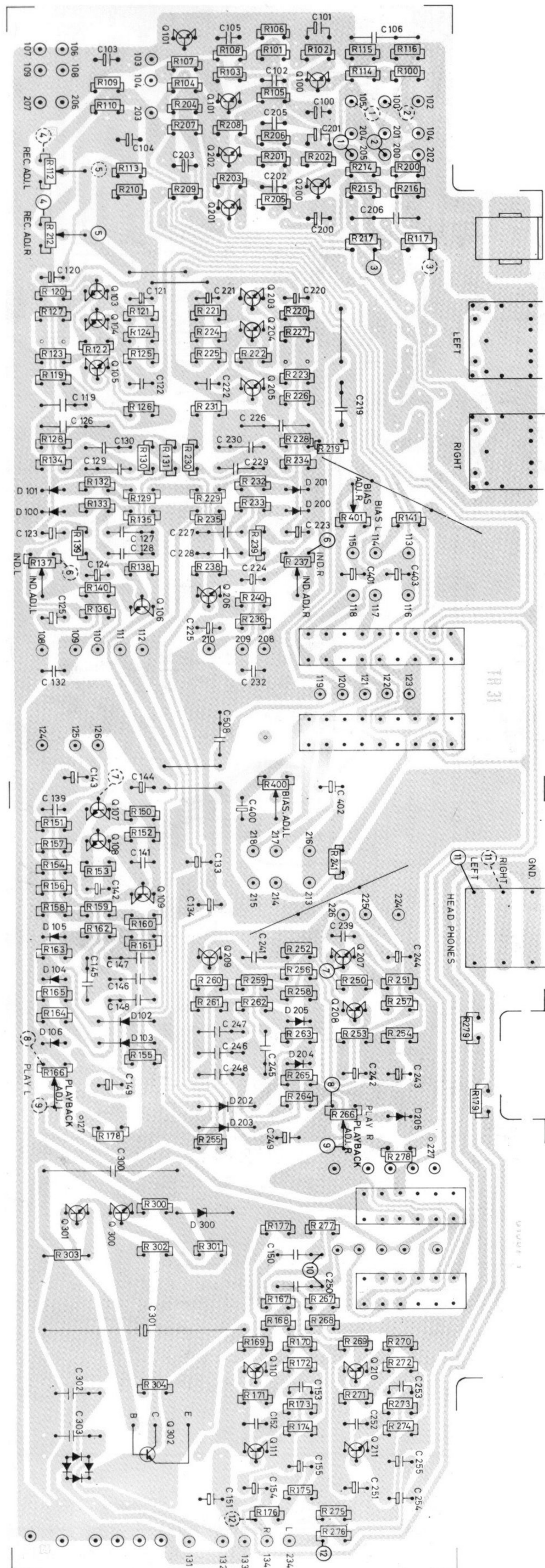

Tone control amplifier board. Seen from printed side.

Board for mic/line amplifiers, record equalizing amplifiers, level indicator amplifiers, booster amplifiers and dc voltage regulator. Seen from printed side.

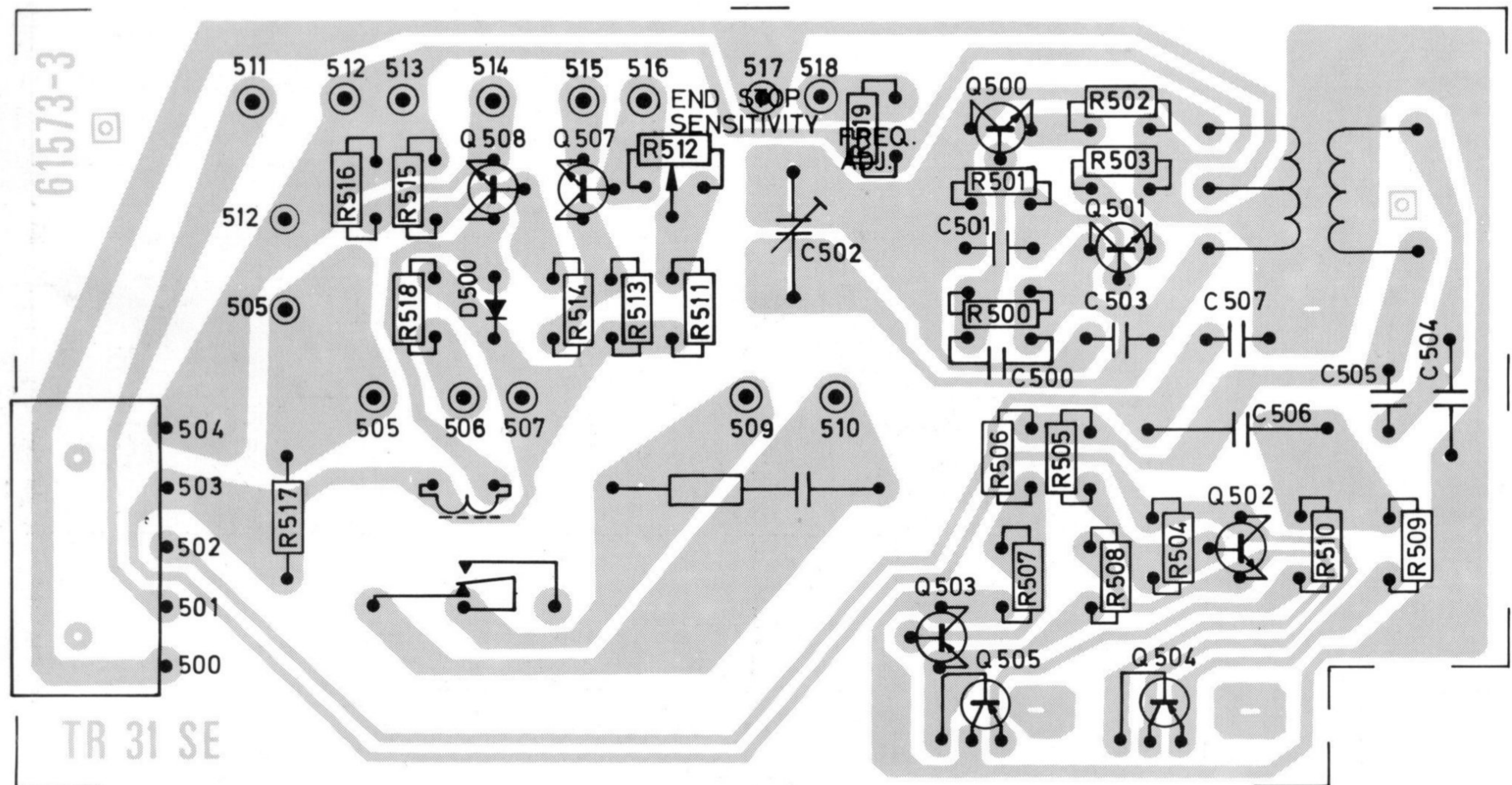

Board for oscillator, bias circuit, and photoelectric end stop circuit. Seen from printed side.

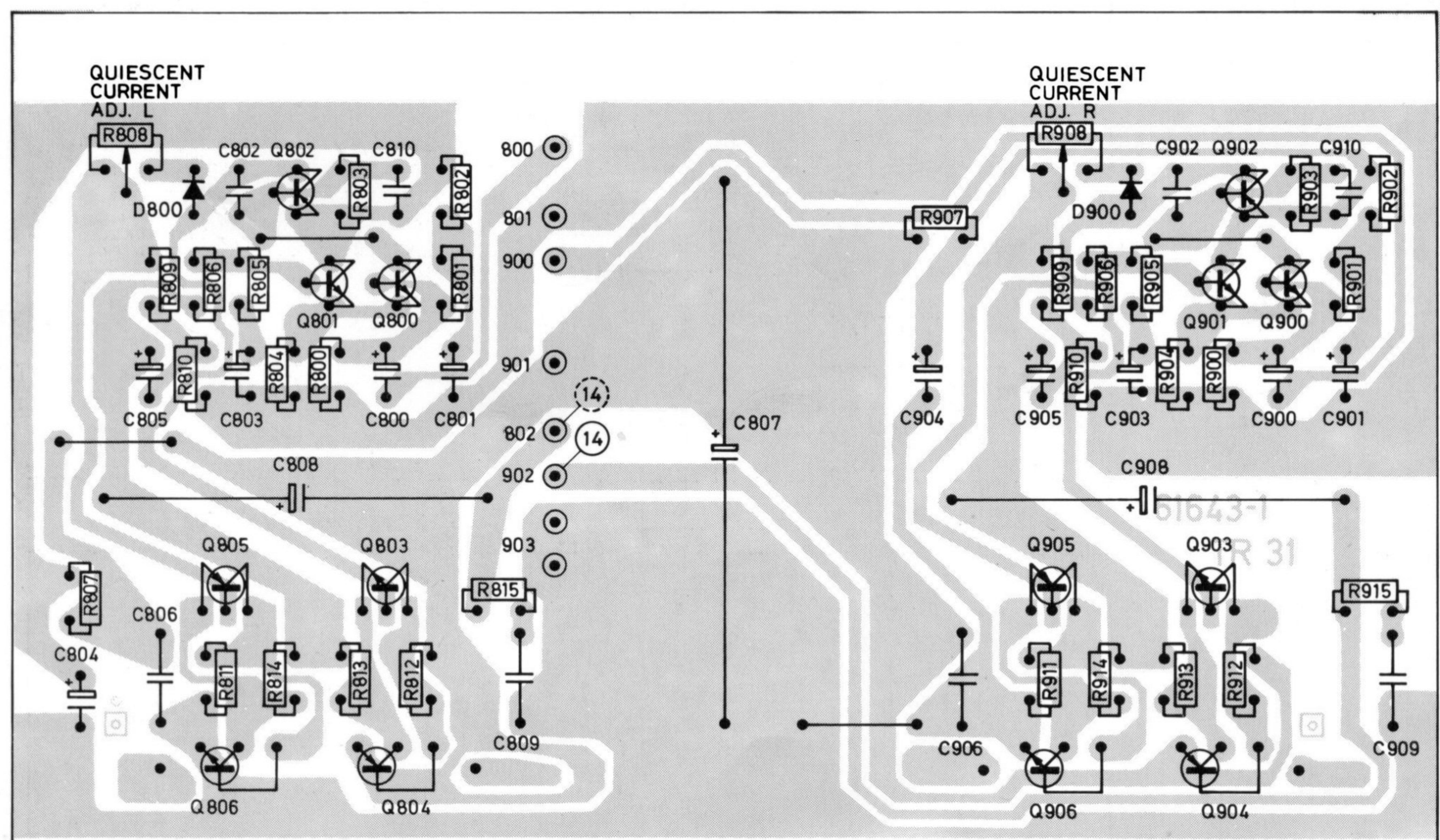

Output amplifier board. Seen from printed side.

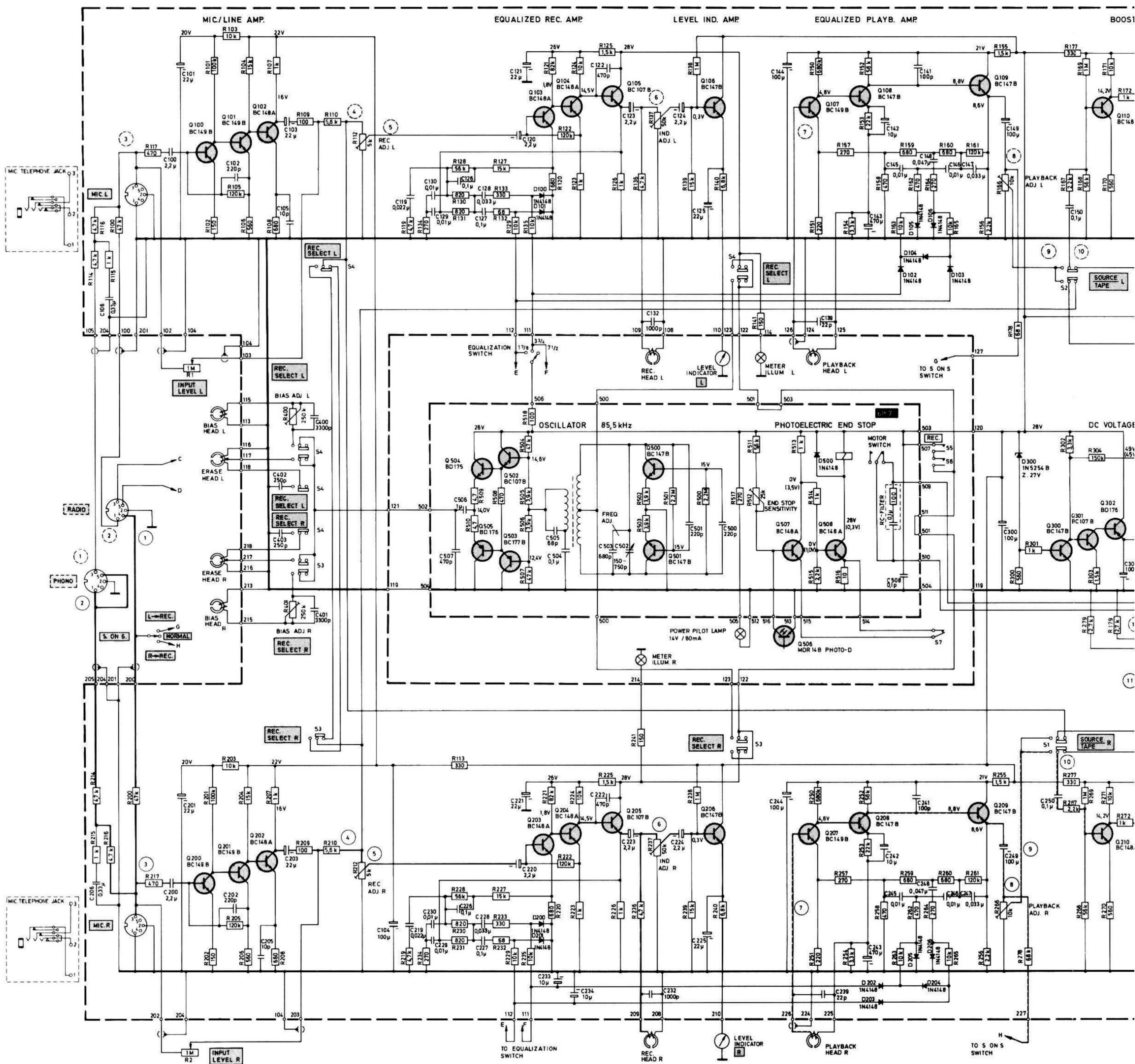

Continued on Page 29

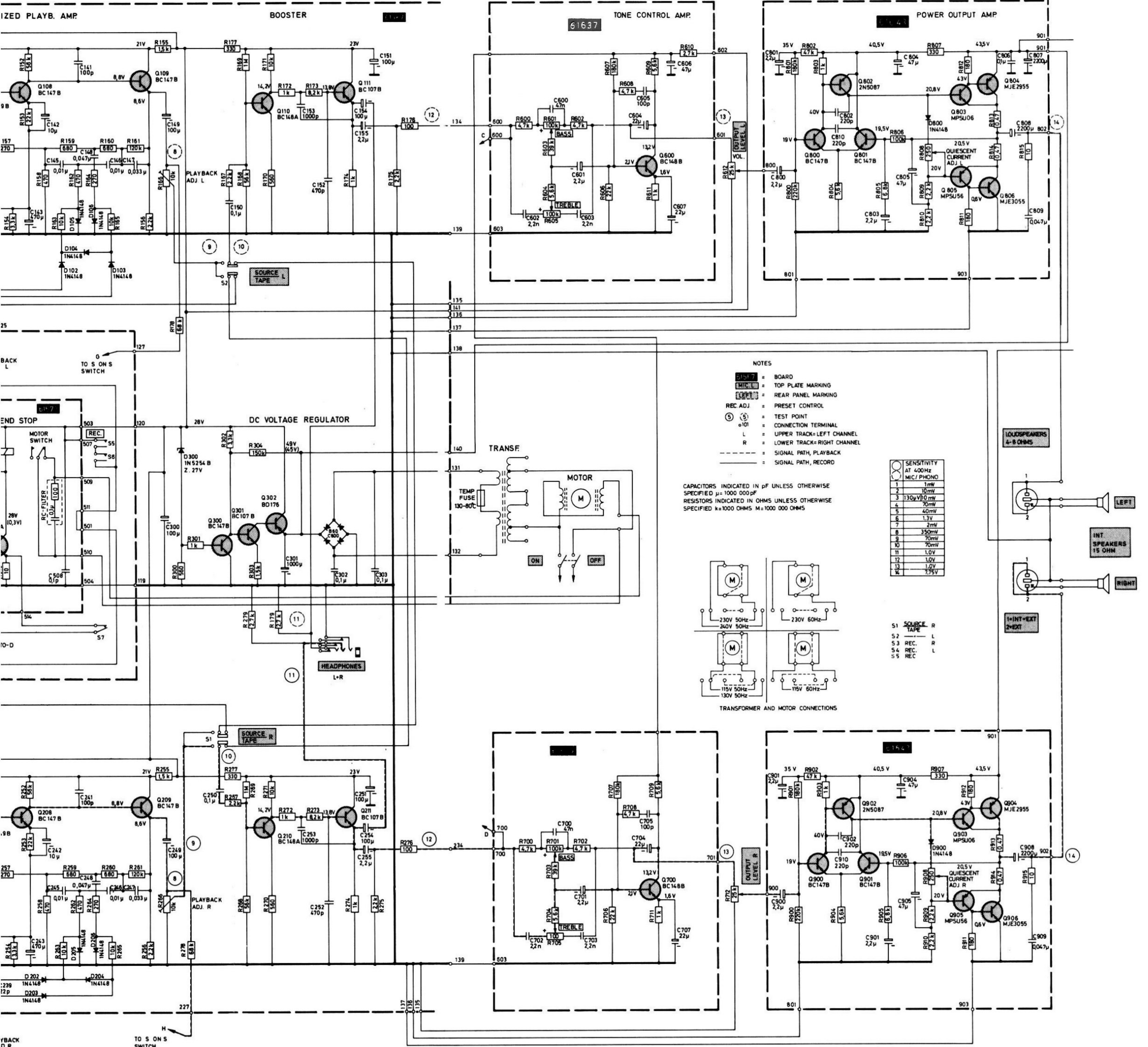

Continued from Page 28



**TANDBERGS RADIOFABRIKK A/S**  
**Postboks 9, Korsvoll, Oslo 8**  
**Norway**

1056-6-74 Printed in Norway by Petlitz