

# X-360D

PROFESSIONAL  
STEREO TAPE DECK  
OPERATOR'S MANUAL

MAGNETIC BRAKE  
3-SPEED MOTOR FOR CAPSTAN DRIVE  
CROSS-FIELD HEAD  
AUTOMATIC VOLUME CONTROL  
(COMPUT-O-MATIC)  
AUTOMATIC DUST MINDER  
AUTOMATIC CONTINUOUS REVERSE  
(REVERSE-O-MATIC)



AKAI®

---

## TABLE OF CONTENTS

---

### I GENERAL INFORMATION

1. Specifications .....	1
2. Controls .....	2
3. 4-track Recording/Playback System .....	4
4. Cross-field Head .....	6
5. Automatic Dust Minder .....	7
6. DIN Jack .....	9
7. Selection of Tape Speeds .....	10
8. Voltage and Cycle Conversion .....	11
9. Magnetic Brake .....	12
10. Trouble Shooting .....	13

### II OPERATING INSTRUCTIONS

1. Tape Loading .....	14
2. Playback .....	14
3. Fast Forward and Rewind .....	16
4. Automatic Stop (Deck only) .....	16
5. Automatic Shut off (Deck and Amplifier) .....	16
6. Automatic Reverse (REVERSE-O-MATIC) .....	17

7. Automatic Reverse (Metallic Sensing Tape) .....	19
8. Manual Reverse .....	19
9. Recording .....	20
10. Recording from Discs .....	23
11. Recording from an External Amplifier .....	24
12. Recording from Another Tape Recorder .....	24
13. Monitoring .....	24
14. Tape Erasing .....	25
15. Sound on Sound .....	25
16. Sound with Sound .....	26
17. Sound over Sound .....	26
18. Remote Control .....	27
19. Tape Splicing and Editing .....	27
20. Head Demagnetization .....	28

### III ACCESSORIES

1. Accessories Optional .....	29
2. Accessories Standard .....	31

### IV SCHEMATIC

# I GENERAL INFORMATION

## 1. SPECIFICATIONS

<b>Tape Speed :</b>	1-7/8, 3-3/4, 7-1/2 and 15 ips
<b>Wow and Flutter :</b>	Less than 0.04% RMS at 7-1/2 ips Less than 0.07% RMS at 3-3/4 ips Less than 0.15% RMS at 1-7/8 ips
<b>Frequency Response :</b>	30 to 18,000 cps $\pm$ 3 db at 3-3/4 ips
<b>Distortion :</b>	Within 1.5% 1,000 cps 0VU at 7-1/2 ips
<b>Signal to Noise Ratio :</b>	Better than 50 db
<b>Input Level :</b>	Microphone ..... more than 0.5 mV Line ..... more than 50 mV DIN ..... more than 5 mV (LOW) or 50 mV (HIGH)
<b>Output Level :</b>	Line ..... 1.23 V (0 VU) DIN ..... 0.4 V
<b>Equalization :</b>	Correct equalization for playback of tapes recorded to the NARTB curve.
<b>Recording Bias Frequency :</b>	100 KC
<b>Recording Level Indicator :</b>	2 VU meter
<b>Recording System :</b>	4-track stereo/monaural, CROSS-FIELD bias system.

<b>Fast Forward and Rewind Time :</b>	75 seconds using 1,200 feet tape at 50 cycles. 60 seconds at 60 cycles.
<b>Maximum Reel Size :</b>	7" reel
<b>Head :</b>	4 Heads ... Erase, playback, record and bias heads.
<b>Motor :</b>	3 motors ... Hysteresis synchronous 3-speed motor for capstan drive. Two 6-pole eddy current out-rotor motors for supply and take-up reels drive.
<b>Transistor :</b>	44 Transistors
<b>Power Supply :</b>	AC 100 to 240 V, 50/60 cycles
<b>Power Consumption :</b>	70~200 VA
<b>Dimensions :</b>	17-1/2"H x 16"W x 10"D (444 H x 406 W x 254 D mm)
<b>Weight :</b>	55 lbs (25 kg)

## 2. CONTROLS

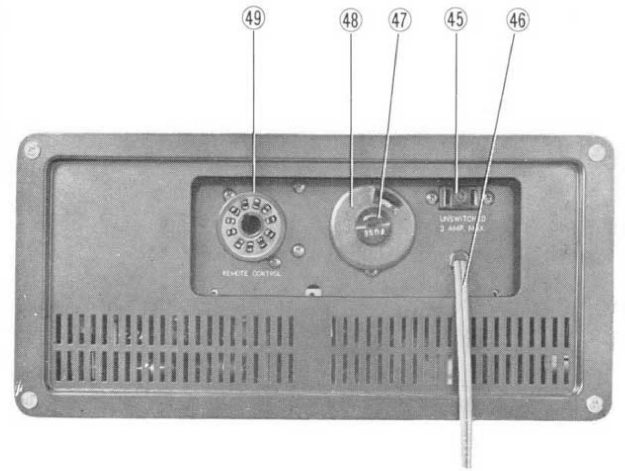
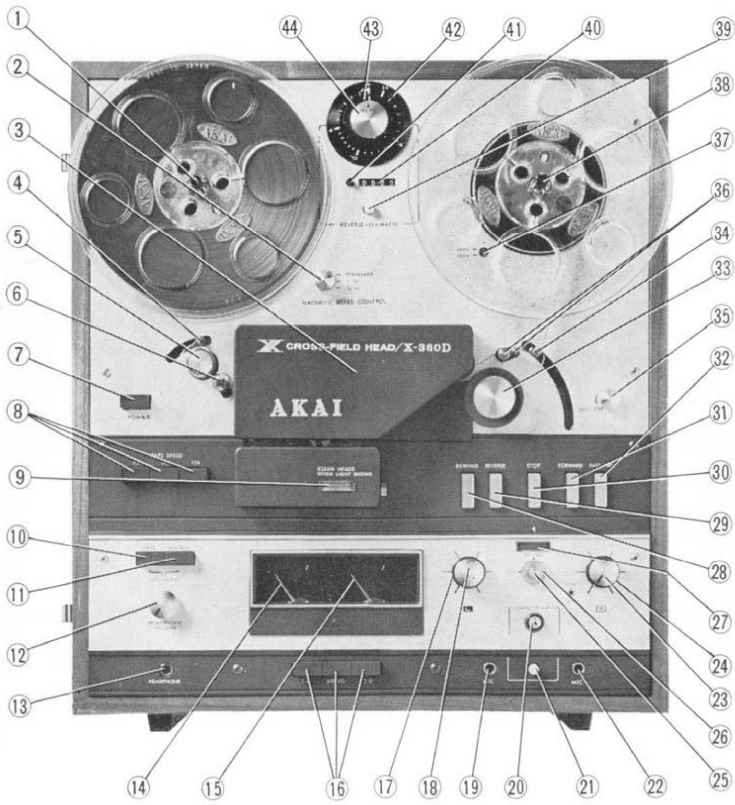

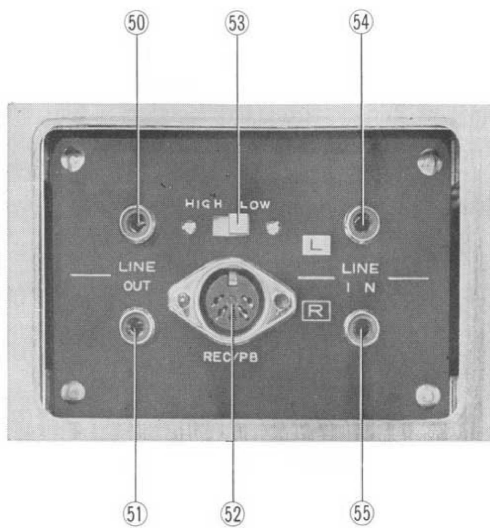

- ① Supply Reel Shaft
- ② Brake Control
- ③ Head Cover
- ④ Tension Arm
- ⑤ Impedance Roller
- ⑥ Tape Cleaner
- ⑦ Power Switch
- ⑧ Tape Speed Selectors
- ⑨ Indicator Lamp of Dust Minder
- ⑩ "TAPE" Button
- ⑪ "SOURCE" Button
- ⑫ Headphone Volume Control
- ⑬ Headphone Jack
- ⑭ VU Meter (Left)
- ⑮ VU Meter (Right)
- ⑯ Track Selectors
- ⑰ Line Record Level Control (Left)
- ⑱ Microphone Record Level Control (Left)
- ⑲ Microphone Jack (Left)
- ⑳ COMPUT-O-MATIC Record Level Indicator
- ㉑ COMPUT-O-MATIC Set Button
- ㉒ Microphone Jack (Right)
- ㉓ Microphone Record Level Control (Right)
- ㉔ Line Record Level Control (Right)
- ㉕ Record Interlock Button
- ㉖ Record Safety Lock
- ㉗ Record Indicator Lamp
- ㉘ Rewind Button
- ㉙ Reverse Button
- ㉚ Stop Button
- ㉛ Forward Button
- ㉜ Fast Forward Button
- ㉝ Pinch Wheel
- ㉞ Take-up Tension Arm
- ㉟ Shut off Switch
- ㊱ Reverse Pine
- ㊲ Cycle Change Switch
- ㊳ Take-up Reel Shaft
- ㊴ REVERSE-O-MATIC Set Button
- ㊵ Tape Counter
- ㊶ Reset Button
- ㊷ Tape Count Scale
- ㊸ Tape Count Meter
- ㊹ Set Dial
- ㊺ AC Outlet
- ㊻ AC Cord
- ㊼ Fuse Post
- ㊽ Voltage Selector
- ㊾ Remote Control Socket
- ㊿ Line Output Jack (Left)
- ① Line Output Jack (Right)
- ② DIN Jack
- ③ HIGH/LOW Change Switch
- ④ Line Input Jack (Left)
- ⑤ Line Input Jack (Right)

### 3. 4-TRACK RECORDING/PLAYBACK SYSTEM

The AKAI X-360D employs a four track system that can be used for either stereo or monaural recording and playback. The desired track or tracks are selected by the TRACK SELECTORS ⑩.

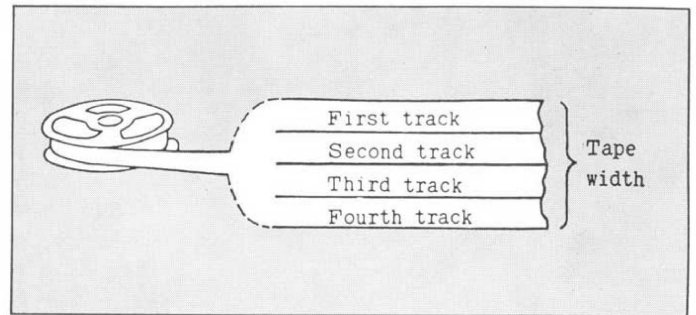

#### 4-Track Stereo Recording/Playback

Stereophonic recording/playback requires the simultaneous use of two tracks. Push the "STEREO" BUTTON of TRACK SELECTORS ⑩.

The first stereophonic recording/playback takes place on tracks 1 and 3, and the second on tracks 2 and 4 after the reels have been turned over.

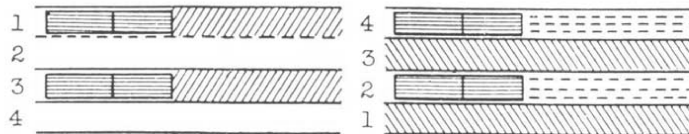

#### 4-Track Monaural Recording/Playback

The monaural recording/playback track sequence should be 1-4-3-2.

(A). Push the "1-4" BUTTON of TRACK SELECTORS ⑩.

The first monaural recording/playback takes place on track 1, and the second on track 4 after the tape reels have been turned over.

(B). Turn the tape reels over.

(C). Push the "3-2" BUTTON of TRACK SELECTORS ⑩.

The third monaural recording/playback takes place on track 3, and the fourth on track 2 after the tape reels have been turned over.

The X-360D does not record in the reversed irection. Using reverse playback, it is not necessary to turn the tape reels over. When the X-360D begins reverse playback, the playback head is automatically shifted to the remaining tracks.

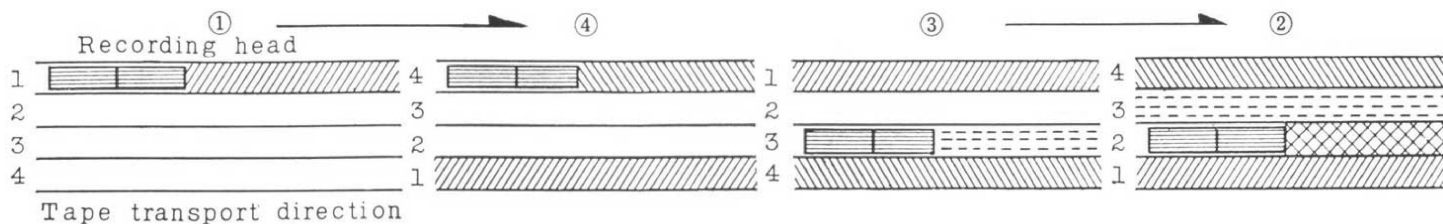

#### 4. CROSS-FIELD HEAD

Cross-field head creates a sensation in the tape recorder world by making a wide range of recording which has never been heard before any tape recorder.

Using this cross-field head, Model X-360D provides a surprising recording performance (30-18,000 cps  $\pm 3$  db at a tape speed of 3-3/4 ips.)

What is superior about cross-field recording? How does it differ from typical recording methods as far as construction is concerned? On these, explanation is given below in sequences:

In the typical recording system, the signal current and the bias current are combined together and applied to the recording head. (Refer to Diagram 1.)

It is well known that the purpose of bias current is recording at high sensitivity with a signal applied on the tape, with no distortion and minimizing noise generation.

However, the bias current providing such an advantage also has an undesirable character. That is, the wide magnetic field of the bias current affects the recorded signal, resulting in weakening or even erasing the signal. This phenomenon is particularly noticeable at high frequencies. In the cross-field system, the signal current is applied to the recording head while the bias current is applied to the bias head.

These two heads are located in different positions, as determined inter-relatively, so that the magnetic field of the bias will not affect the signal recorded on the tape, even when a sufficient bias is applied. This allows the recorded signal to remain on the tape with high fidelity.

**Diagram 1. Ordinary recording system**

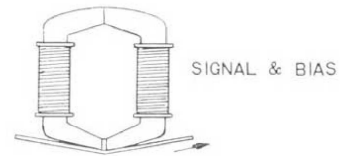

**Diagram 2. Cross-field recording system**

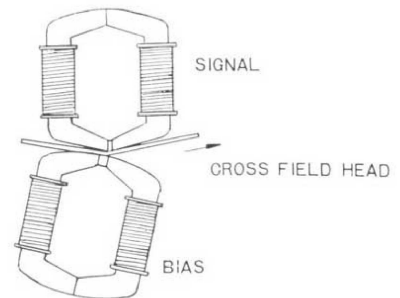



## 5. AUTOMATIC DUST MINDER

It is imperative for quality performance of a tape recorder to keep the heads neat and clean at times.

Dust and magnetic particles from the tape tend to deposit on the heads after prolonged use of the tape recorder. This would

result in poor head-to-tape contact, deteriorating the sound quality and sensitivity.

What is worse, such dust would cause a fatal drop in recording, playback and erase quality levels.

### EXAMPLE

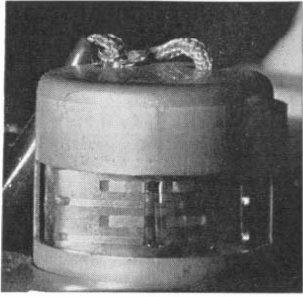

CLEAN HEAD

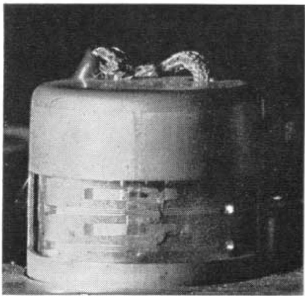
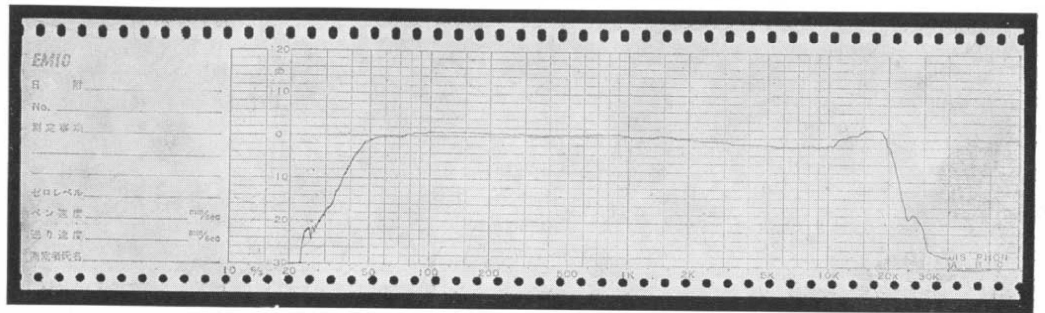

DUSTY HEAD

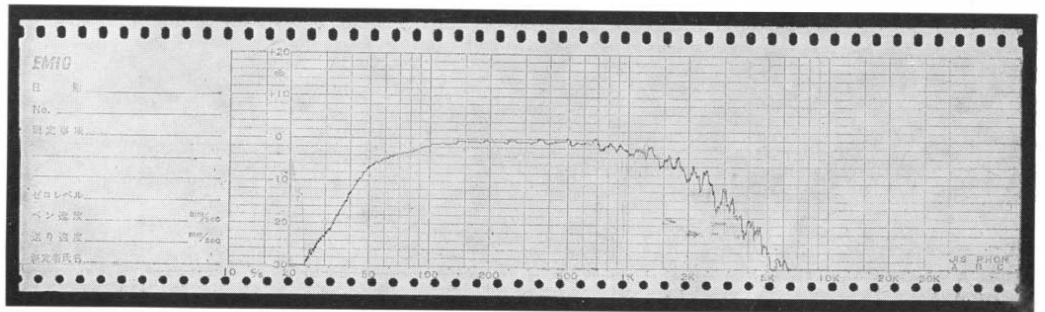

As mentioned, before, the contamination on tape recorder head affects the performance of tape recorder to a large extent. To investigate the contamination of tape recorder head in a conventional method, it used to be only means to do it with naked eyes. AKAI's newly developed "Automatic Dust Minder", however, made it quite easy to detect the contamination of tape recorder head. "Dust Minder" features a pilot lamp which works as indicator when the tape recorder head is contaminated to a degree which affects the performance of the tape recorder. Therefore, the operator of a tape recorder can save troublesome physical inspection on the tape recorder head with naked eyes to assure perfect performance by cleaning contaminated tape recorder head except at the



time of indicator's warning. AKAI's Head Cleaning Kit (Accessory No. HC-500) is recommended for removing the foreign matters deposited on the heads. If this kit is not available, use alcohol.

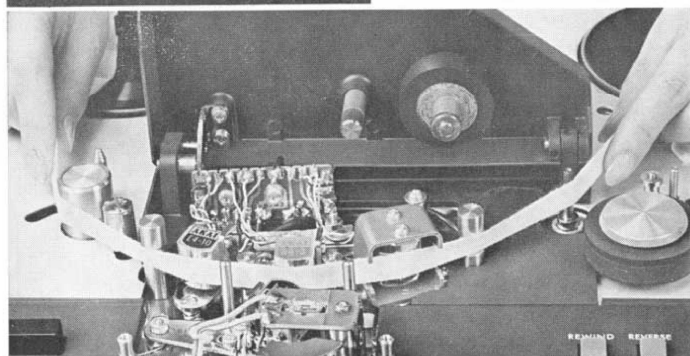

## TAPE CLEANER

A squeaking noise may annoy the operator while recording or playing. This may be caused either by poor tape or by ambient conditions of temperature and humidity. When foreign material adheres to the recording tape, this material piles up at the recording head, affecting volume or quality of sound.

The Model X-360D is provided with a tape cleaner, a tape cleaner pad properly soaked in silicon oil to eliminate noise. If the tape cleaner pad is contaminated so that it does not do good cleaning of the tape, loosen the upper screw and turn the tape cleaner pad to the unused side.

When both surfaces of the pad are contaminated, the pad should be replaced with a new one. Upon replacing, one or two drops of silicon oil should be placed on the felt for absorption.

**NOTE:** When an excessive amount of silicon oil is applied, the tape surface may become discolored and sticky.

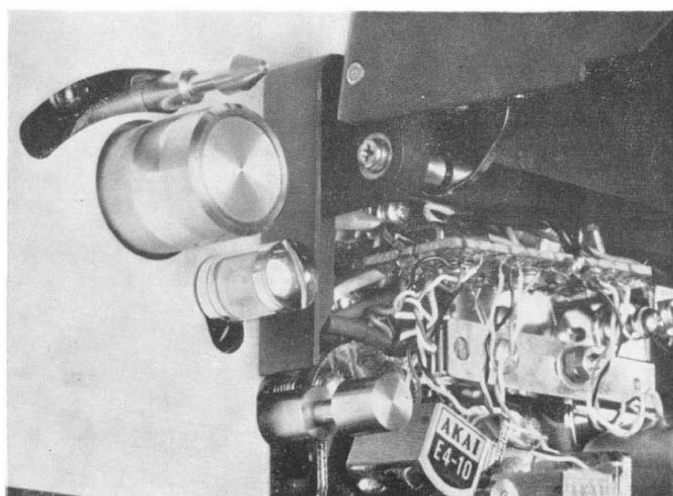

## 6. DIN JACK

The DIN JACK <sup>52</sup> is provided at right side of the Model X-360D for interconnecting the Model X-360D with an external stereo amplifier that has the same connection jack. This system will permit easy recording and playback of stereophonic programs through an external stereo amplifier as the complexity of connecting or disconnecting more than 4 separate plugs from the Model X-360D's panel side is not needed.

If your amplifier is not equipped with the DIN jack and the use of this one connection system is required, AKAI DR-110 is usable.

**NOTE :** When the output level of an external amplifier is more than 50mV, set the HIGH/LOW CHANGE SWITCH <sup>53</sup> to "HIGH". But, when output level is more than 5 mV, set it to "LOW".

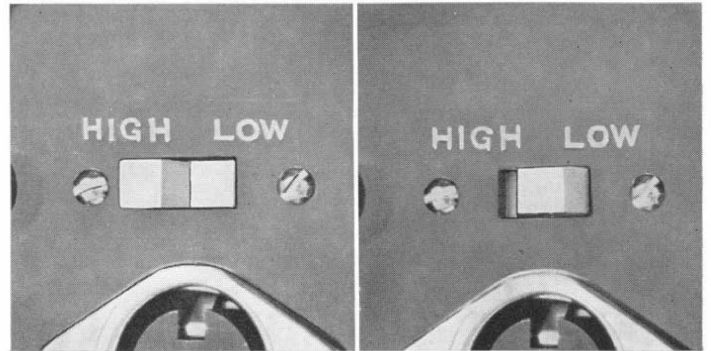

### Front view of DIN JACK

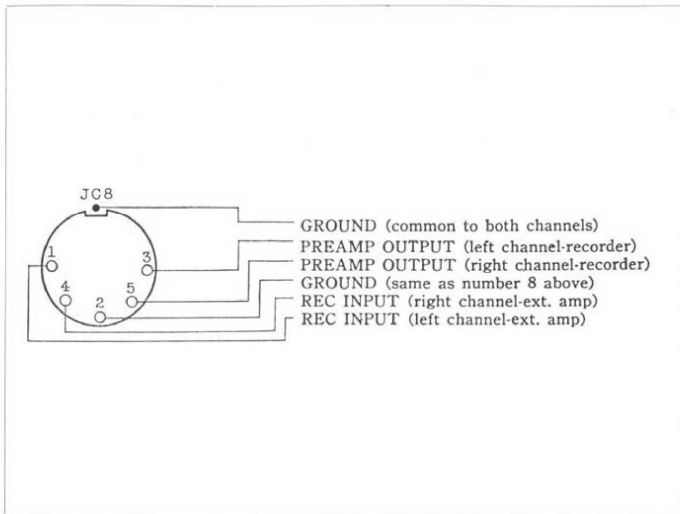

## 7. SELECTION OF TAPE SPEEDS

The X-360D operates on 4 tape speeds, 15, 7-1/2, 3-3/4 and 1-7/8 ips.

\*1-7/8 ips . . . . The 1-7/8 ips tape speed is obtained by pushing the "1-7/8" button of TAPE SPEED SELECTORS ⑧.

\*3-3/4 ips . . . . The 3-3/4 ips tape speed is obtained by the "3-3/4" button of TAPE SPEED SELECTORS ⑧.

\*7-1/2 ips . . . . The 7-1/2 ips tape speed is obtained by the "7-1/2" button of TAPE SPEED SELECTORS ⑧.

\*15ips . . . . . The 15ips tape speed is obtained by the "7-1/2" button of TAPE SPEED SELECTORS ⑧, and replace the PINCH WHEEL ⑩ with the 15ips PINCH WHEEL (standard accessory) and mount the 15ips CAPSTAN (standard accessory) on the capstan shaft.

### RECORDING TIME

4-TRACK STEREO			
TAPE LENGTH	TAPE SPEED		
	1-7/8 ips	3-3/4	7-1/2
1200 ft	4 hrs	2	1
1800	6	3	1.5
2400	8	4	2
4-TRACK MONO			
1200	8	4	2
1800	12	6	3
2400	16	8	4

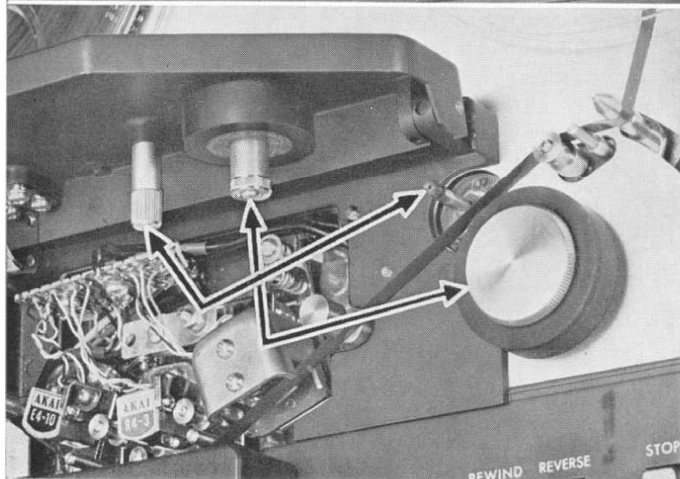

## 8. VOLTAGE AND CYCLE CONVERSION

### POWER VOLTAGE ADJUSTMENT

The Model X-360D is operatable anywhere in the world. With the built-in stepdown power transformer, the user can easily readjust the recorder to any one of the six stages of power voltage from 100 to 240 volts A.C. Generally, the recorder's input voltage is preset for the forwarding territory.

The user is requested to check the previously set voltage before operation.

This can be seen at the rear of the recorder.

If another voltage is required, readjusting of the voltage can be made in accordance with the following instructions.

- (1) Take off the FUSE POST ④7 as shown in Fig. A. Then, pull out the PLUG of VOLTAGE SELECTOR ④8 and insert it so that the desired voltage will appear.
- (2) The VOLTAGE SELECTOR ④8 is a plug-in type movable in six steps, 100/110/120/200/220/240. For example, if the power voltage distributed in your area is 100 volts A.C., reset the selector to 100 mark.
- (3) Change fuse according to voltage.  
Fuse: 100V-120V 2A, 200V-240V 1A

**CAUTION:** Disconnect the power plug from the AC consent before readjusting power voltage. To maintain optimum performance and to prolong the life of your machine, it is important that the line voltage be held within 10 percent deviations, from the standard voltage.

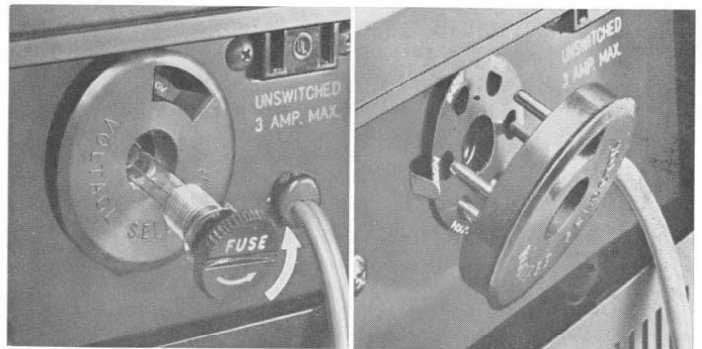

(A)

(B)

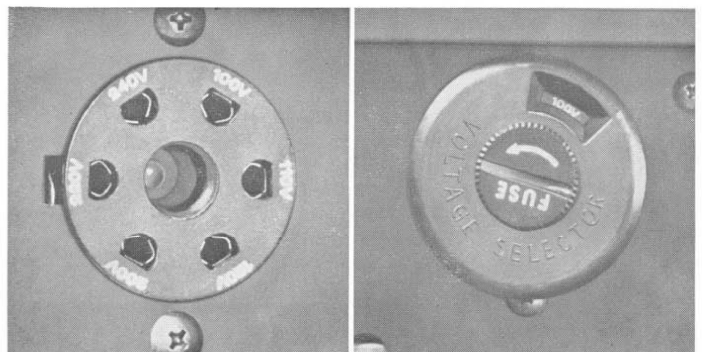

(C)

(D)

### POWER CYCLE CHANGE

Correct tape speed is not obtainable if the CYCLE CHANGE SWITCH ③⑦ are not properly adjusted. The CYCLE CHANGE SWITCH ③⑦ is located at the center of the deck top panel.

Using a screw driver, set the SWITCH ③⑦ to "50Hz" or 60Hz".

#### CAUTION:

Do not attempt to rotate the CYCLE CHANGE SWITCH ③⑦ when the motor is not running.

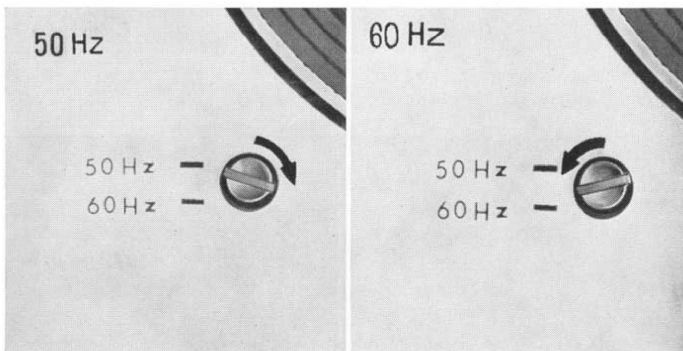

## 9. MAGNETIC BRAKE

Conventional type tape recorders, in many instances, employ rubber braking system which, however, sometimes causes inefficiency in braking and troubles due to worn-out of rubber section of the braking system. AKAI's magnetic braking system has been developed in order to eliminate such a weak point of conventional braking system and been successful to utilize electrical force with the aid of rubber auxiliary used for the braking system which stops the tape instantly on the spot desired without giving the tape forces to loosen or to tense. In addition this braking system can be used almost semi-permanently.

Note: Set the BRAKE CONTROL ② to "1/2mil", "1mil" or "STANDARD" as required.

Thickness of tape	Brake Control
Less than 1/2mil	1/2mil
1/2-1mil	1mil
more than 1mil	STANDARD

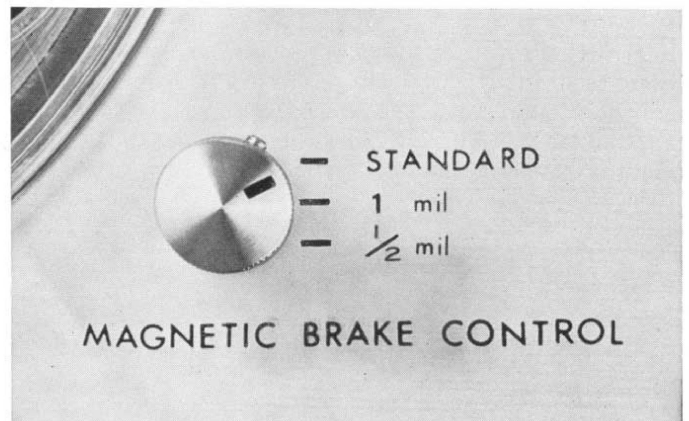

## 10. TROUBLE SHOOTING

IMPORTANT : READ THE OPERATING INSTRUCTIONS CAREFULLY BEFORE OPERATING YOUR RECORDER.

The symptoms listed below do not necessarily indicate a malfunction of your tape recorder. If your machine exhibits any of these symptoms, take the indicated action.

- A. Loss of sensitivity or tone quality may be due to :
  - Dusty or dirty heads-clean the heads.
  - Reversed tape-place the dull side of the tape toward the heads.
  - Improper voltage-check voltage input and adjustment.
- B. Irregularity of the tape transport may be due to :
  - Grime adhering to the heads-clean the heads.
  - Dirty tape surface-use a clean tape.
  - Bent take up reel-straighten the take up reel.
- C. If your machine will not record, insure that the following are in the correct position :
  - RECORD INTERLOCK BUTTON (25)
  - Plugs

If any problem arises, take your machine to the authorized AKAI agent in your area or to the Service Department of the AKAI company in Tokyo, Japan.

## II OPERATING INSTRUCTIONS

### 1. TAPE LOADING

Place your recording tape on the SUPPLY REEL SHAFT ① and the empty reel on the TAKE-UP REEL SHAFT ⑳. Thread the tape as illustrated by the dotted line. To keep the reels from falling down, lock the reels with the retainers provided on the top of the REEL SHAFTS.



### 2. PLAYBACK

#### Stereo

Connect the power cord and load a tape.

- (A) Push the POWER SWITCH ⑦.
- (B) Push the "STEREO" BUTTON of TRACK SELECTORS ⑯.
- (C) Push the "7-1/2", "3-3/4" or "1-7/8" BUTTON of TAPE SPEED SELECTORS ⑧ as requested.
- (D) Push the "TAPE" BUTTON ⑩.

**The X-360D does not include power amplifier nor loud speakers. It, therefore, is necessary to provide an external amplifier and speakers for playback.**

- (E) Connect both LINE OUTPUT JACKS (⑤⑩ and ⑤⑪) to TAPE INPUT JACKS or AUX JACKS of the external stereo amplifier. Also, connect two loud speakers to the amplifier.

#### **IMPORTANT:**

**The output level at the X-360D's output jack is 1.23V at maximum. Check your existing amplifier before operation to determine with input terminals should be used.**

- (F) After the above operation, push the FORWARD BUTTON ⑩.
- (G) Adjust the VOLUME CONTROL of the external amplifier to desired volume.



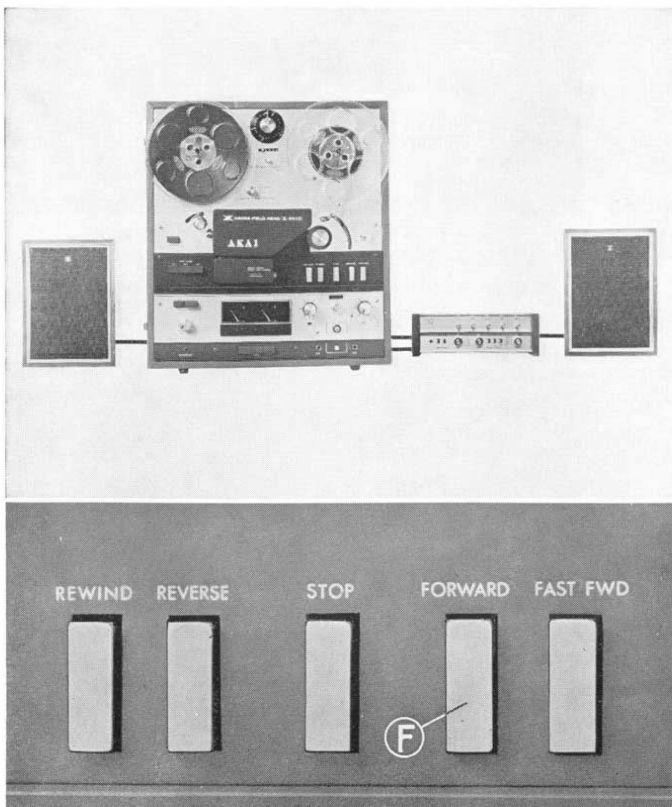

### **Monaural**

Only the left channel amplifier is used for monaural playback. So, for monaural playback, substitute the following steps (B) and (E) of the stereo procedure, and follow the rest of the stereo procedure.

- (B) Push the "1-4" BUTTON of TRACK SELECTORS ⑩ for playback on track No. 1 and 4, and the "3-2" BUTTON for playback on track No. 3 and 2.
- (E) Connect LINE OUTPUT JACK ⑤ to LEFT TAPE INPUT JACK or AUX JACK of the external amplifier.

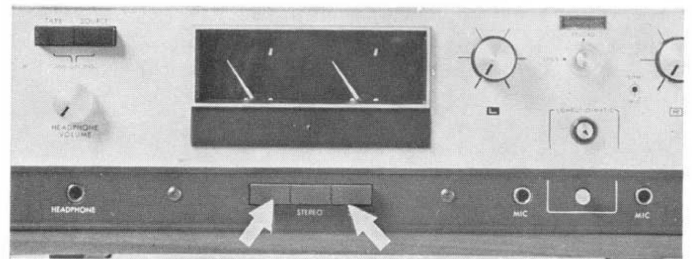

### 3. FAST FORWARD AND REWIND

To use fast-forward or rewind, push the FAST FORWARD BUTTON ⑩ or the REWIND BUTTON ⑨.

Only the STOP BUTTON ⑪ should be used to stop fast-forward or rewind.

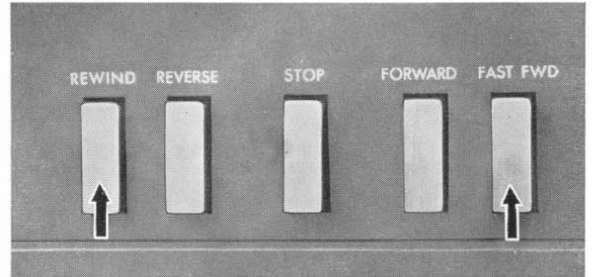

### 4. AUTOMATIC STOP (DECK ONLY)

The TAKE-UP TENSION ARM ⑭ is connected to a micro-switch that automatically stops the deck if the tape should break, pile up, or pass entirely through to the take up reel. Under normal operating conditions, the arm will be held in the approximate position. If the arm reaches the position as shown in Figure, the micro-switch will function and stop the deck.

### 5. AUTOMATIC SHUT-OFF (DECK AND AMPLIFIERS)

When the SHUT-OFF SWITCH ⑮ is set to "SHUT OFF" in Figure, the deck and the amplifiers are connected to the TAKE-UP TENSION ARM ⑭ microswitch. If the tape should break, pile up, or pass entirely through to the take up reel, the TAKE-UP TENSION ARM ⑭ will reach the position shown in Figure and the deck and amplifiers will be turned off automatically. At that time, if the external amplifier is connected to AC OUTLET ⑰ of X-360D, the external amplifier will be turned off automatically also.

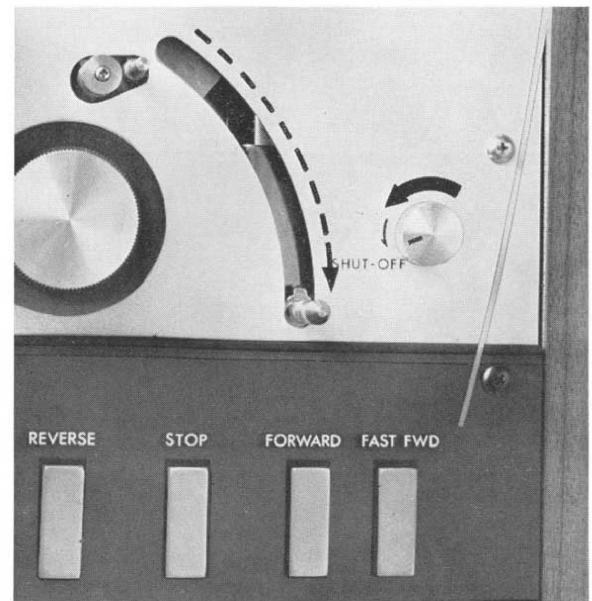

## 6. AUTOMATIC REVERSE (REVERSE-O-MATIC)

Automatic reverse is used for playback only. When the meter is used for automatic reverse the X-360D will give continuous playback in both directions between any two points (A and B) selected on the tape.

- (A) Align the TAPE COUNT METER ④③ and the SET DIAL ④④ with the "0" on the TAPE COUNT SCALE ④②. (Figure A). This step establishes point A on the tape.
- (B) Advance the tape, by either the FORWARD BUTTON ③① or the FAST FORWARD BUTTON ③②.  
As the tape feeds forward, the TAPE COUNT METER ④③ moves counter clockwise as shown in Figure B.  
Push the STOP BUTTON ③⑦ when the tape has advanced to the desired point B.
- (C) Rotate the SET DIAL ④④ until its mark is aligned with the mark on the TAPE COUNT METER ④③ as shown in Figure C.
- (D) Push the REVERSE-O-MATIC SET BUTTON ③⑧.
- (E) Using the REWIND BUTTON ②⑧ or REVERSE BUTTON ②⑨, rewind the tape back to the starting point A.  
As the tape rewinds or playback in reverse, the TAPE COUNT METER ④③ moves clockwise. The starting point A is reached when the mark on the TAPE COUNT METER ④③ is aligned with the "0" on the TAPE COUNT SCALE ④②.
- (F) Push the FORWARD BUTTON ③①.  
The X-360D will now playback from point A to point B, and upon reaching point B will reverse itself and playback to point A where it will reverse itself again for playback to point B. This operation will continue automatically, as show in Figure D, until the STOP BUTTON ③⑦ is pushed.  
When the FORWARD BUTTON ③① is pushed again, playback will resume in the forward direction until reversal occurs at point B.

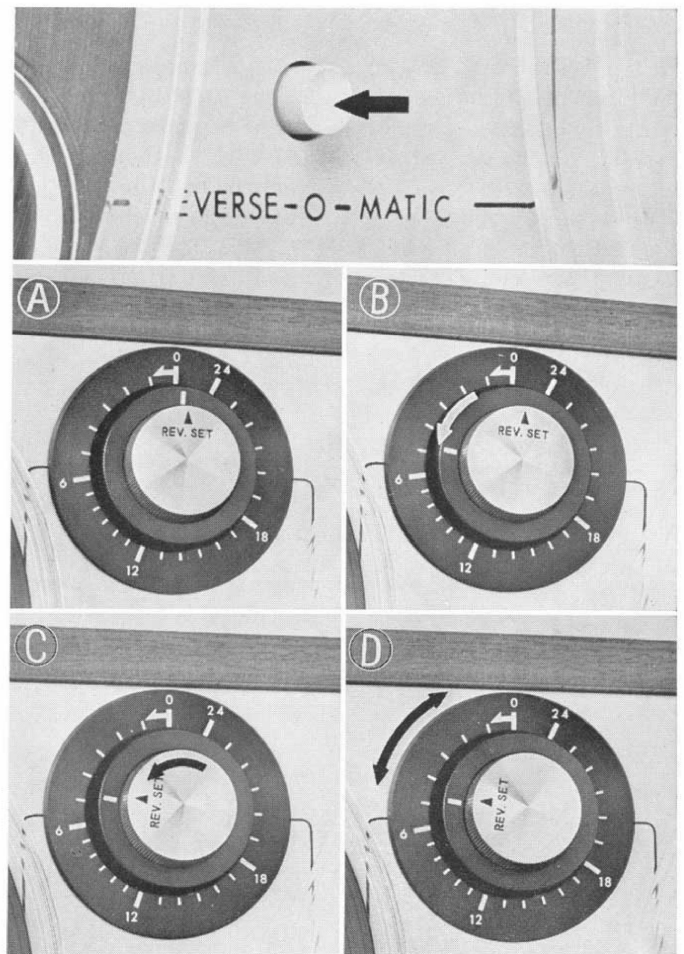

**NOTE :**

In step (B), if the FORWARD BUTTON ③① is used to advance the tape, it is not necessary to push the STOP BUTTON ③② at point B. Approaching the desired point B, perform steps (C) and (D). In step (B), rotate the SET DIAL ④④ counter clockwise until its mark has slightly passed the mark on the TAPE COUNT METER ④③. The X-360D will begin reverse play as soon as the mark on TAPE COUNT METER ④③ aligns itself with the mark on SET DIAL ④④. Steps (E) and (F) are not necessary, however, the information contained there following is applicable.

An alternate procedure for automatic reverse is to let the graduated TAPE COUNT SCALE ④② represent 2,400 feet of tape. 2,400 feet is the maximum length of tape that can be reversed using the TAPE COUNT METER ④③. The intervals between numbers represent 100 feet.

## 7. AUTOMATIC REVERSE (METALLIC SENSING TAPE)

Automatic reverse with metallic sensing tape is used for playback only. The sensing tape method is convenient if the tape in use is too long to be measured by the TAPE COUNT METER

④③

- (A) Push out the REVERSE-O-MATIC SET BUTTON ③⑨
- (B) Splice a two inch piece of metallic sensing tape to the end or at the desired reverse point of the tape in use. Reversal will occur when the metallic sensing tape makes simultaneous contact with the REVERSE PINS ③⑥. Reverse (playback) will continue until the end of the tape passes the TAKE-UP TENSION ARM ③④ and the deck is shut off.

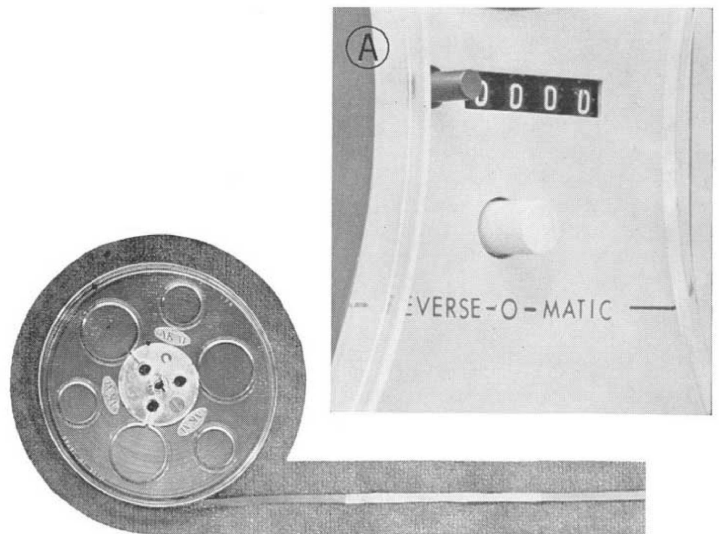

## 8. MANUAL REVERSE

Pushing the REVERSE BUTTON ②⑨ will put the X-360D into the reverse (playback) function anytime before the mark on the TAPE COUNT METER ④③ is aligned with the mark on the SET DIAL. ④④

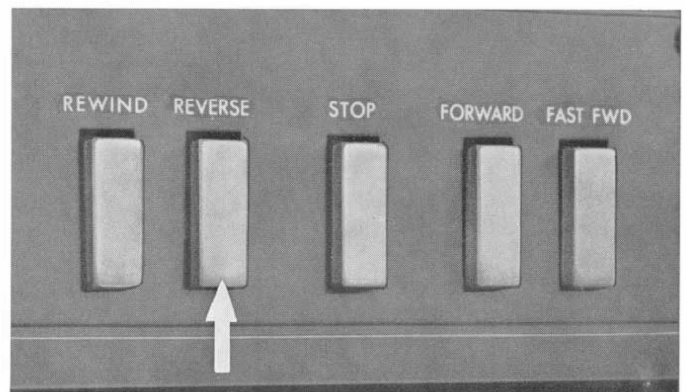

## 9. RECORDING

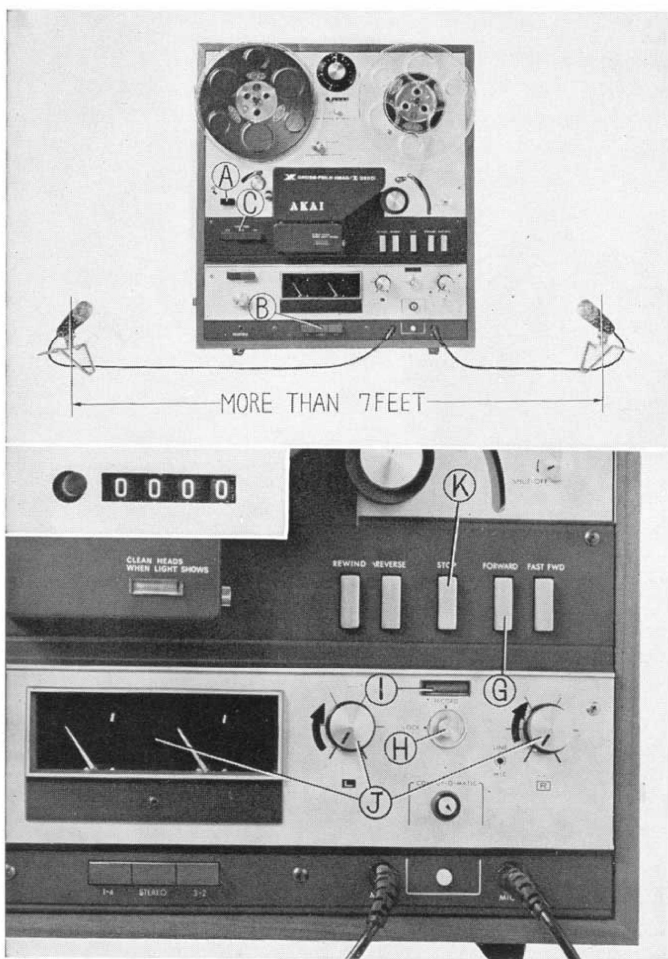

### STEREO

Connect the power cord and load a tape.

- (A) Push the POWER SWITCH ⑦.
- (B) Push the "STEREO" BUTTON of TRACK SELECTORS ⑯.
- (C) Push the "7-1/2" "3-3/4" or "1-7/8" BUTTON of TAPE SPEED SELECTORS ⑧ as required.
- (D) Push the RESET BUTTON ④① and set the INDEX COUNTER ④② to "0000".  
The INDEX COUNTER ④② provides a reference for locating a position on the tape.
- (E) Insert the microphone plugs into the MICROPHONE JACKS ⑱, ⑳.  
Maintain a distance of at least seven feet between the microphones.
- (F) Push either the "SOURCE" BUTTON ⑪ or the "TAPE" BUTTON ⑩.  
If the "SOURCE" BUTTON ⑪ is used, the program source may be monitored as it is being recorded.  
If the "TAPE" BUTTON ⑩ is used, the recorded signal will be monitored as the tape passes the playback head.
- (G) Push the FORWARD BUTTON ⑳① to start recording.
- (H) Push the RECORD INTERLOCK BUTTON ⑳⑤.  
The RECORD INTERLOCK BUTTON ⑳⑤ is equipped with the RECORD SAFETY LOCK ⑳⑥ to prevent inadvertent erasure of recorded tapes. Turn the RECORD SAFETY LOCK ⑳⑥ clockwise until its red mark is aligned with "RECORD".
- (I) Check that the RECORD INDICATOR LAMP ⑳⑦ is on.  
If the light is not on, the X-360D will not record.
- (J) Microphone volume level may be adjusted and balanced by the MICROPHONE RECORD LEVEL CONTROLS ⑳⑧, ⑳⑨.

Normal recording should not exceed "OVU" mark on the VU METERS<sup>14</sup>, <sup>15</sup>.

- (K) Push the STOP BUTTON <sup>30</sup> to stop recording. To resume recording, the FORWARD BUTTON <sup>31</sup> and the RECORD INTERLOCK BUTTON <sup>25</sup> must be depressed again.

**MONAURAL**-For monaural recording, substitute the following steps for steps (B) and (E) and add step (L). Follow the rest of the stereo procedure.

- (B) Push the "1-4" or "3-2" BUTTON of TRACK SELECTORS <sup>16</sup> as required.
- (E) Insert the microphone plug into the LEFT MICROPHONE JACK <sup>19</sup>. Only the left amplifier is used for monaural recording.
- (L) Turn the tape reels over to record on track 4 or track 2 as applicable.

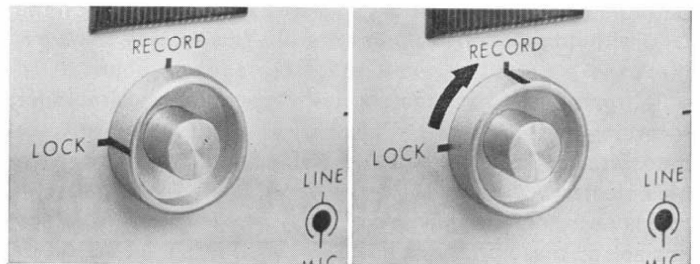
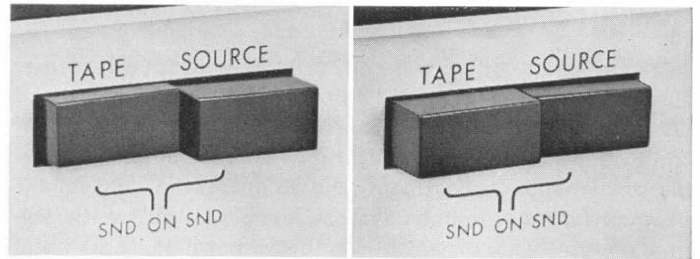
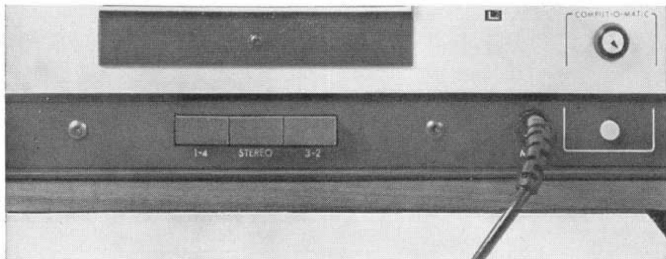

## COMPUT-O-MATIC

In recording sound with a conventional type tape recorder, the operator, in order to obtain optimum level not to exceed OVU at the maximum, is supposed to adjust the volume control by hand as he watches VU meters. To save such a troublesome manual adjustment and to meet the subsequent demand for an automatic system, so called "automatic volume control system" which is actually known as "automatic gain control system" has been developed. Its features, as shown in Fig. (B), that the sound to be recorded is kept automatically within a certain level which is fixed based on the OVU without adjusting volume control. This system, however, disclosed substantial poorness in reproducing sound e. g. a flat reproduction characteristics of sound not desirable for recording musical sound, difficulty to distinguish human voice made at short distance and long distance and other unavoidable defects. AKAI's newly developed COMPUT-O-MATIC system is an automatic volume control system in real sense which has solved these problems. In AKAI's COMPUT-O-MATIC volume control system, as shown in Fig. (C), the maximum level of the sound to be recorded is automatically adjusted to OVU and other levels proportionately to it. In other words, to start recording, the SET BUTTON of COMPUT-O-MATIC system has to be pushed down, then the RECORD LEVEL INDICATOR start moving automatically until it stops at the maximum level which is OVU and other levels are to be adjusted proportionately. COMPUT-O-MATIC volume control system saves manual adjustment by an operator as he watches VU meters, by doing it automatically. Therefore, in order to obtain a perfect recording effect, it is recommended to do the test recording before starting actual recording, after setting REC-

ORD LEVEL INDICATOR.

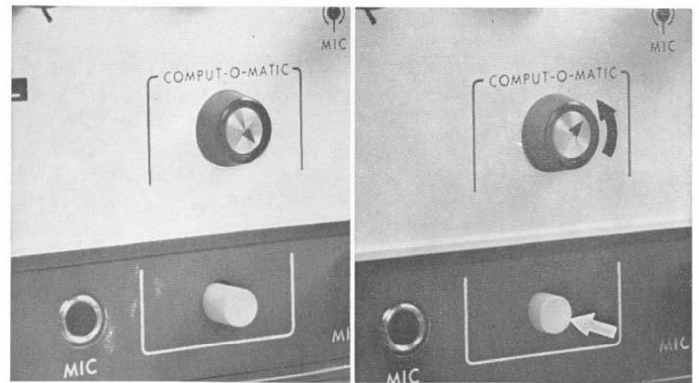



## 11. RECORDING FROM AN EXTERNAL AMPLIFIER

If an external amplifier or tuner-amplifier combination is used, connect the TAPE OUTPUT leads of the external amplifier to the LINE INPUT JACKS ⑤4, ⑤5 in step (E) of the recording procedure. VU level is controlled with the LINE RECORD LEVEL CONTROLS ⑰ ⑳. The X-360D will record any source that can be selected on the external amplifier.

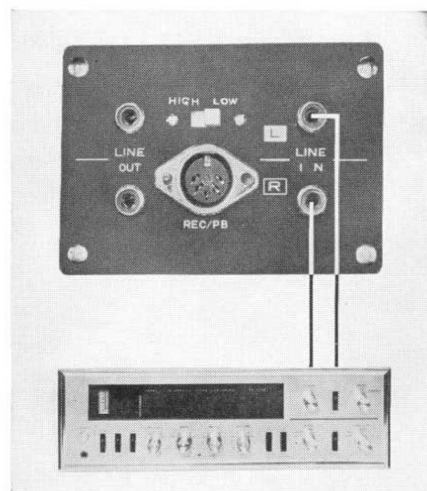

## 12. RECORDING FROM ANOTHER TAPE RECORDER

Connect the LINE OUTPUT JACKS or EXTERNAL SPEAKER JACKS of playback machine to the LINE INPUT JACKS ⑤4, ⑤5 of X-360D in step (E) of recording procedure. VU level is controlled with the LINE RECORD LEVEL CONTROLS ⑰, ⑳.

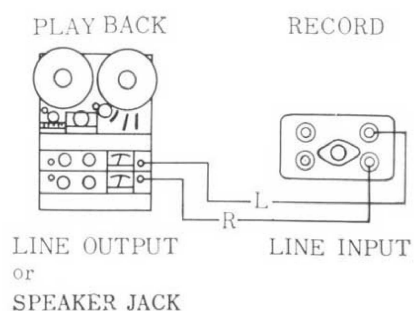

## 13. MONITORING

Step (F) of the recording procedure describes monitoring. Monitoring is made by connecting the stereo headphone to STEREO HEADPHONE JACK ⑬. The volume is controlled with HEADPHONE VOLUME CONTROL ⑫.

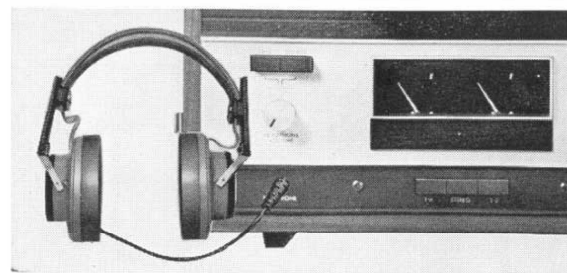

## 14. TAPE ERASING

Any signal information previously recorded on a tape will be erased automatically as a new recording is made on the same tape. Thread the tape, and place in normal record position. There should be no plugs connected to recorder's input jacks. A BULK TAPE ERASER is recommended for quick and complete erasure.

## 15. SOUND ON SOUND

### First Recording

- Confirm that there are no connections to the LINE INPUT JACKS ⑤④ ⑤⑤.
- Push the "1-4" BUTTON of TRACK SELECTORS ⑩ for recording on track 1.
- Insert the microphone plug in the LEFT MICROPHONE JACK ⑩.
- Push the "TAPE" BUTTON ⑩ or "SOURCE" BUTTON ⑪.

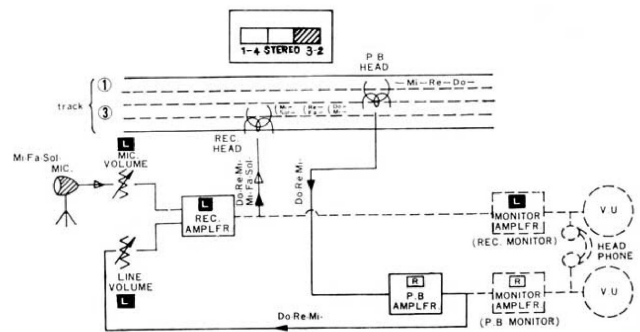
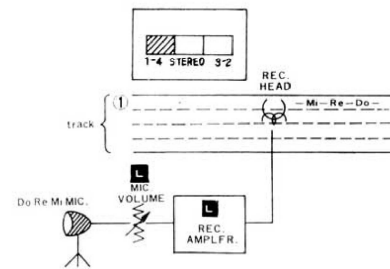
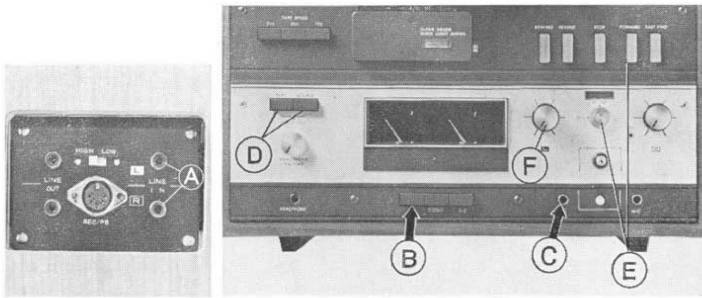

- (E) Push the FORWARD BUTTON ⑧ and RECORD INTERLOCK BUTTON ② for making the first recording, i.e. Do-Re-Mi.
- (F) Adjust the LEFT MICROPHONE RECORD LEVEL CONTROL ⑬ to the proper level on the VU meter.
- (G) When the first recording is complete, rewind the tape to the starting position.

#### Second Recording

- (H) Confirm that the "TAPE" BUTTON ⑩ and the "SOURCE" BUTTON ⑪ are both in the IN position.
  - (I) Push the "3-2" BUTTON of TRACK SELECTOR ⑮ for recording on track 3 while listening to track 1.
  - (J) Increase the LEFT LINE RECORD LEVEL CONTROL ⑰ to approximately maximum.
  - (K) Connect the stereo headphones to monitor the first recording on the left channel (track 1).
  - (L) Push the FORWARD BUTTON ⑧ and the RECORD INTERLOCK BUTTON ②.
- The first recording will be heard through the headphones.
- (M) Reset the LEFT LINE RECORD LEVEL CONTROL ⑰ to the proper level by watching the left channel VU meter.
  - (N) After the reset, rewind the tape again to the starting point.
- Push the FORWARD BUTTON ⑧ and the RECORD INTERLOCK BUTTON ②.
- The second recording, Mi-Fa-Sol, is made on track 3 as the first recording, Do-Re-Mi, is monitored in the headphones. The two will be completely merged on track 3, i.e., (Do-Re-Mi, Mi-Fa-Sol).
- (O) The third and subsequent recordings are made the same as the second by switching "1-4", "3-2" BUTTON of the TRACK SELECTORS ⑮.

## 16. SOUND WITH SOUND

To record sound with sound, substitute the following step for step (J) of the sound on sound procedure and eliminate step (M).

- (J) Decrease the LEFT LINE RECORD LEVEL CONTROL ⑰ to minimum.

## 17. SOUND OVER SOUND

Sound over sound recording is a mixing recording.

- A. Connect the plug of the microphone to MICROPHONE JACK and the output terminal of external amplifier or record player to LINE INPUT JACK.
- B. Microphone volume level may be adjusted by MICROPHONE RECORD LEVEL CONTROL, and line volume level by LINE RECORD LEVEL CONTROL.

## 18. REMOTE CONTROL

All operating functions of the X-360D can be controlled remotely by using the optional accessory, remote control unit (ACC. No. RC-16). Connect the plug of remote control to the REMOTE CONTROL SOCKET ④9.

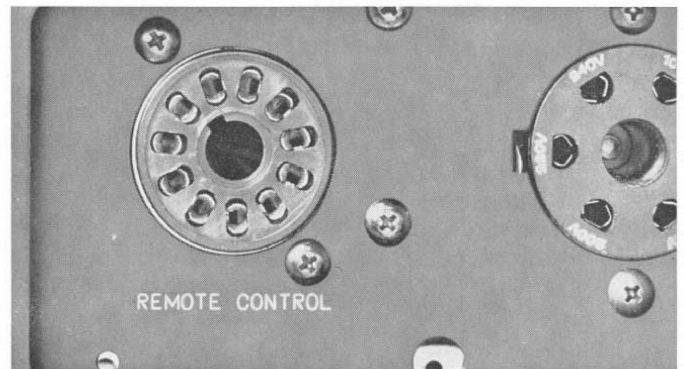

## 19. TAPE SPLICING AND EDITING

Superimpose the tapes and cut them diagonally as illustrated. (This diagonal cutting eliminates the "click" or "pop" sound of the splice.)

Register the cut ends and apply a splicing tape on the glossy side of the record tape.

Press the splice tape with fingers firmly to secure the ends evenly. Trim off excess splicing tape. Preferably, cut the recording tape slightly along its edge as illustrated by the dotted lines. This eliminates the possibility of a sticky splice. Tape splicing using scissors requires skillful work. The scissors should not be magnetized. But, our specially designed portable splicer can do the job with ease.

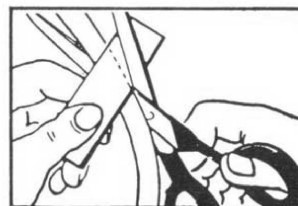
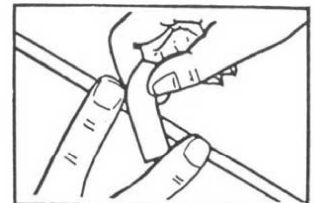
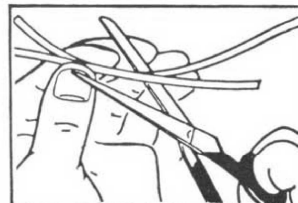

## 20. HEAD DEMAGNETIZATION

Normally, in all tape recorders, the heads will become slightly magnetized. A slightly magnetized head will partially erase a recorded tape with high frequencies suffering the greatest losses. Severe magnetization will result if magnetized tools are used in the vicinity of the heads. The X-360D has a built-in head demagnetizing circuit; however, periodic demagnetization with a demagnetizer is still recommended. After opening the HEAD COVER ③, the heads can be demagnetized by touching the heads lightly with the demagnetizer and making small circular motions over the entire head surface and head housing.

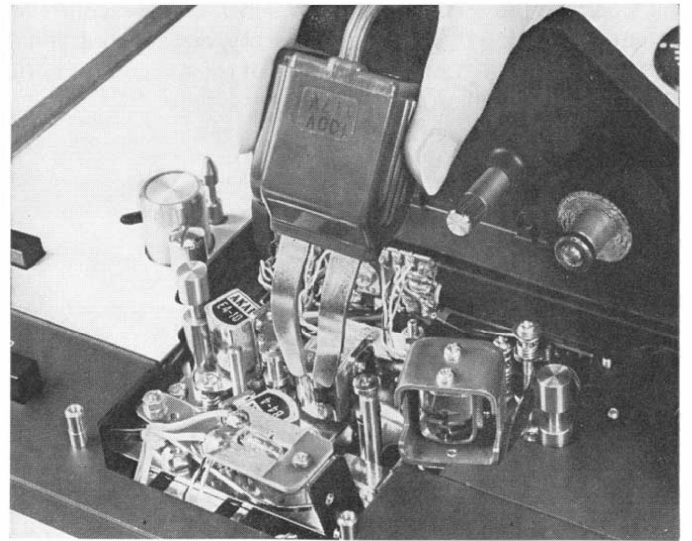

## 1. ACCESSORIES OPTIONAL

Remote Control for X-360 & X-360D No. RC-16



Head Demagnetizer No. AH-6



Condenser Microphones No. CM-15

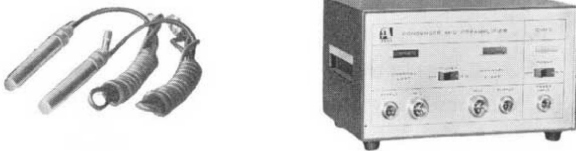

Tape Eraser No. ATE-7



Dynamic Microphones No. DM-13

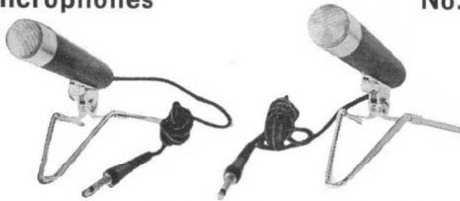

Stereo Headphone No. ASE-9S



Tape Splicer No. AS-3

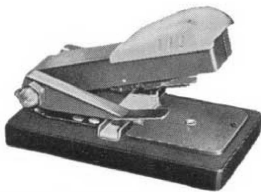

Head Cleaning Kit No. HC-500



## AKAI Magnetic Tape & Tape Reel

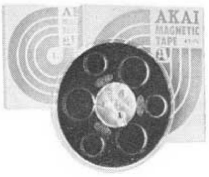

### AKAI Magnetic Tape

- AT-5S ( 600 feet)
- AT-7S (1,200 feet)
- AT-10S (2,400 feet)
- AT-5L ( 900 feet)
- AT-7L (1,800 feet)
- AT-10L (3,600 feet)



### AKAI Tape Reel

- ATR-5 (for 5")
- ATR-7 (for 7")

## Akai Connecting Cords



D-100



DR-110



DM-120

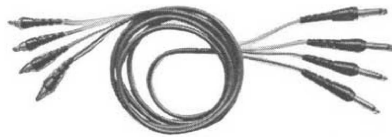

RM-130

The stereo speaker system, model SW-130 is specially designed to match impedance to Akai's stereo tape recorders and to obtain the best results. You will always be able to derive true Hi-Fi sound reproduction with the combination of the SW-130 and any Akai Stereo Tape Recorder.

## Model SW-130

- Speaker : 12" Woofer & 3-1/2" Tweeter
- Impedance : 8 ohms
- Max. Power Input : 25 watts
- Frequency Range : 50~18,000 cps.
- Dimensions : 16-1/2" W x 22-1/2" H x 12-1/8" D
- Weight : 28.9 lbs (piece)

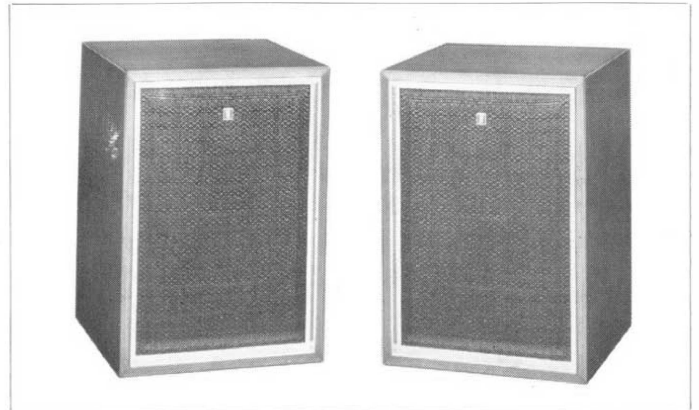

## 2. ACCESSORIES STANDARD

7" Automatic Metallic Reel .....	1
15 ips Adaptor Kit .....	1
Spare Fuse .....	2

Silicon Oil .....	1
Felt Pad .....	2
Operator's Manual .....	1





---

MANUFACTURED & DISTRIBUTED BY  
AKAI ELECTRIC CO., LTD.  
AKAI TRADING CO., LTD.  
12, 2-chome, Higashi-Kojiya,  
Ohta-ku, Tokyo, Japan

---

Price ¥ 360.00  
US \$ 1.00