

GRAMOPONES

22GC 010/00/01/03



With this, the Service notes of the 22GC010, code number 4822 726 1. 0155 is deleted.

Technical data

Supply voltage : 9 Vd. c.
 Current consumption : 60 mA
 Dimensions : 274x212 mm
 Speeds : 33 1/3 - 45 - 78
 P. U. heads : GP306 - GP310 -
 : GP224 - GP228

Lubricating

Lubricate the points marked A in Fig. 1 with Shell Alvania 2, code number 4822 390 20001.
 Lubricate the points marked B in Fig. 1 with lubricant 10, code number 4822 390 10003.
 Lubricate point C in Fig. 1 with Shell Tellus 33, code number 4822 390 10006.

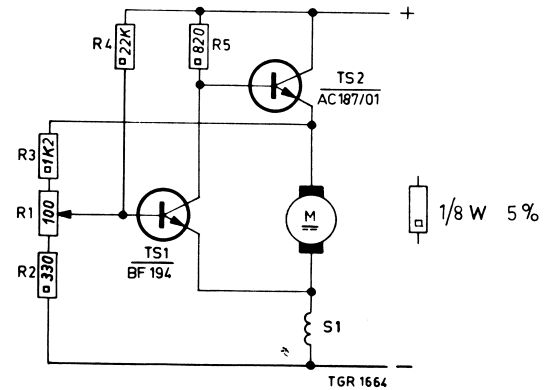

TGR 1664

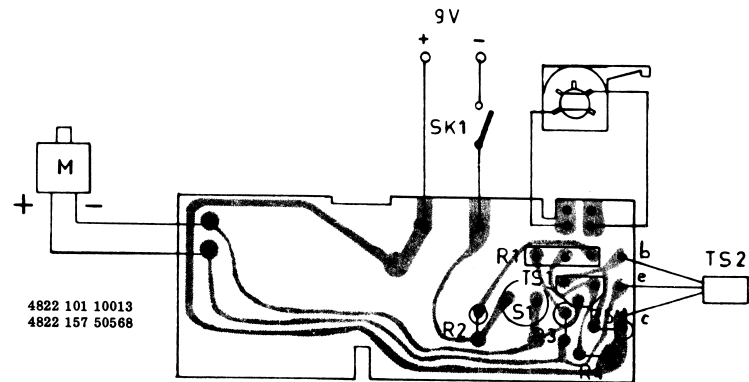

R1 100 Ω 4822 101 10013
 S1 4822 157 50568

TGR 1704

P1-6 Philips 22GC010

LIST OF MECHANICAL PARTS

Code number

Pos. Description

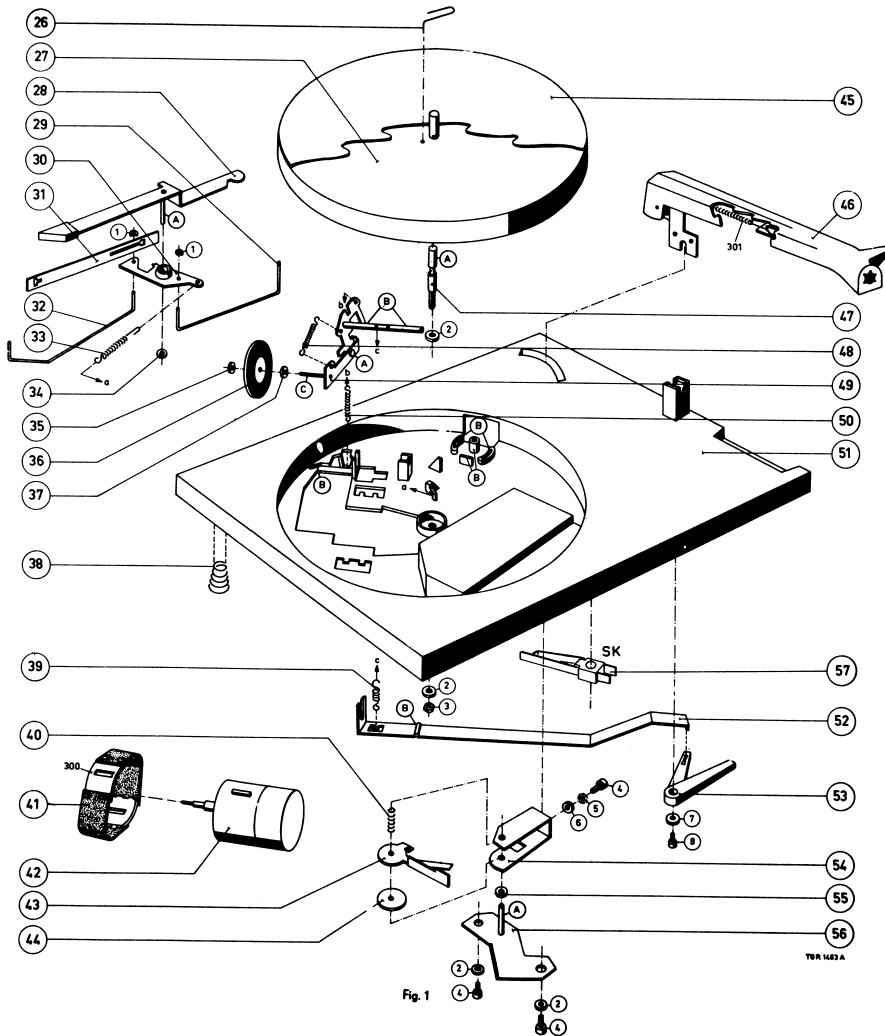

Pos.	Description	Code number
1	Circlip 2 mm	4822 530 70001
2	Ring 3 mm	4822 532 10235
3	Nut 3 mm	4822 505 10005
4	Screw 3x10 mm	4822 502 10041
5	Toothed lockwasher	4822 530 80005
6	Ring 3 mm	4822 532 10235
7	Ring 2 mm	4822 532 10201
8	Screw 2x5 mm	4822 502 10026
26	Locking spring	4822 492 60882
27	Turntable	4822 528 10156
28	Trip lever	4822 402 20039
29	Switching rod	4822 535 90484
30	Switching plate	4822 402 60216
31	Stop spring	4822 492 60881
32	Switching rod	4822 535 90483
33	Tension spring	4822 492 30533
34	Nylon circlip	4822 532 50266
35	Nylon circlip	4822 532 50266
36	Idler wheel	4822 528 70177
37	Ring	4822 532 50044
38	Suspension spring	4822 492 50476
39	Tension spring	4822 492 30501
40	Pressure spring	4822 492 50569
41	Band for motor suspension	4822 466 60332
42	Motor with pulley	4822 361 20057
43	Friction bracket	4822 402 30032
44	Friction ring	4822 532 50403
45	Turntable mat	4822 466 50056
46	Pick-up arm	4822 251 70088
47	Turntable spindle	4822 535 80361
48	Tension spring	4822 492 30535
49	Idler wheel bracket	4822 402 40016
50	Tension spring	4822 492 30534
51	Mounting plate	4822 444 30087
52	Switching bracket	4822 402 60215
53	Switching lever	4822 402 60217
54	P. U. arm bracket	4822 402 60214
55	Ring	4822 532 50044
56	Plate	4822 402 60213
57	Switch SK	4822 278 90007