

Service
Service
Service



Service Manual



TABLE OF CONTENTS

	Page
Location of pc boards & Version variations	1-2
Technical Specifications	1-3
Measurement setup	1-4
Service Aids, Safety Instruction, etc.	1-5
Disassembly Instructions & Service positions	2
Service Test Programs & DEMO mode	3
Set Block diagram	4
Set Wiring diagram	5
Front Board	6
Mains Board	8
ETF7 Tape Module	9
3CDC-LLC-MCD1 Module	10
Combi Board	11
Set Mechanical Exploded view & parts list	12



© Copyright 2002 Philips Consumer Electronics B.V. Eindhoven, The Netherlands
All rights reserved. No part of this publication may be reproduced, stored in a retrieval system or transmitted, in any form or by any means, electronic, mechanical, photocopying, or otherwise without the prior permission of Philips.

Published by KC 0203 Service Audio Printed in The Netherlands Subject to modification



3139 785 30028

Version 1.0



PHILIPS

SERVICE TEST PROGRAM

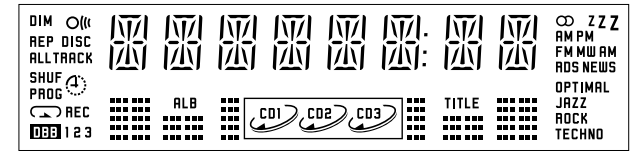
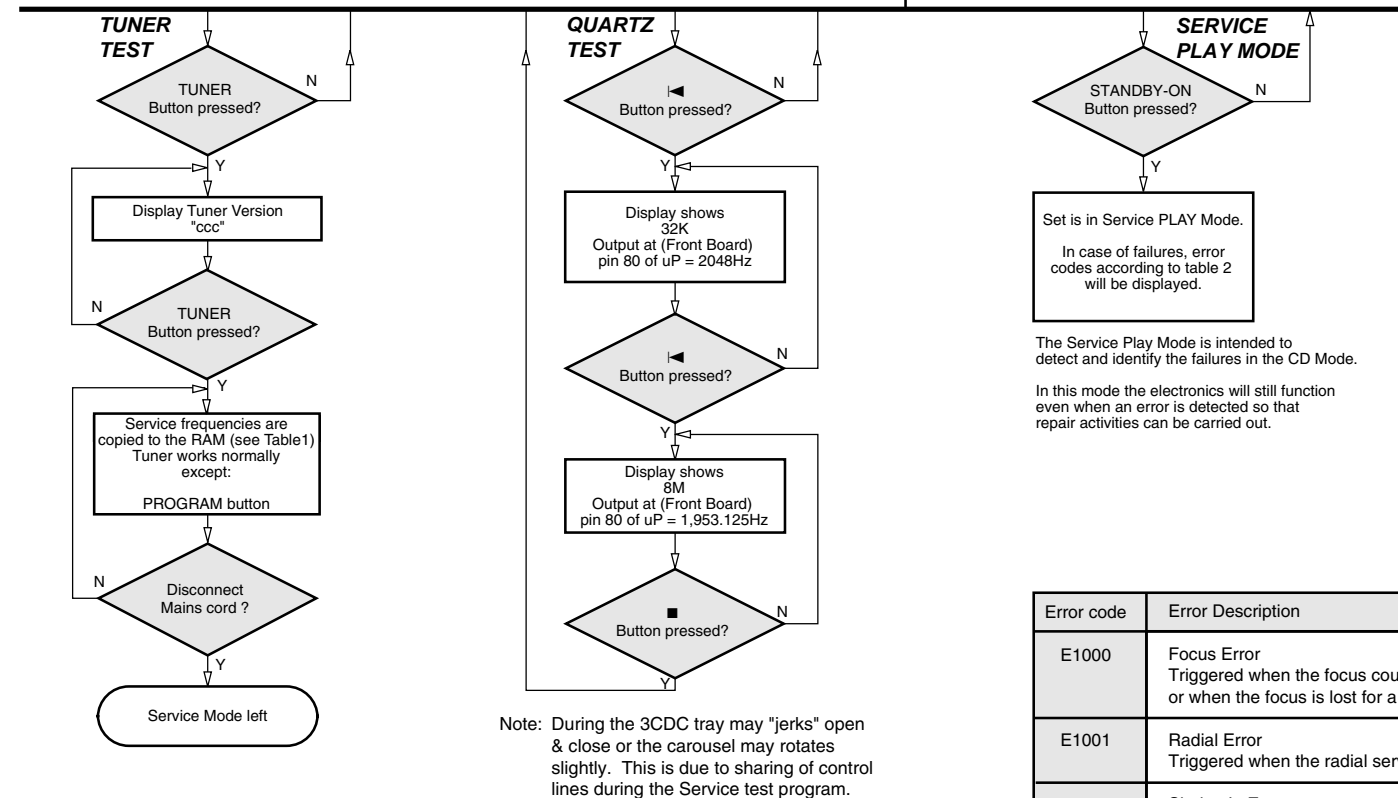
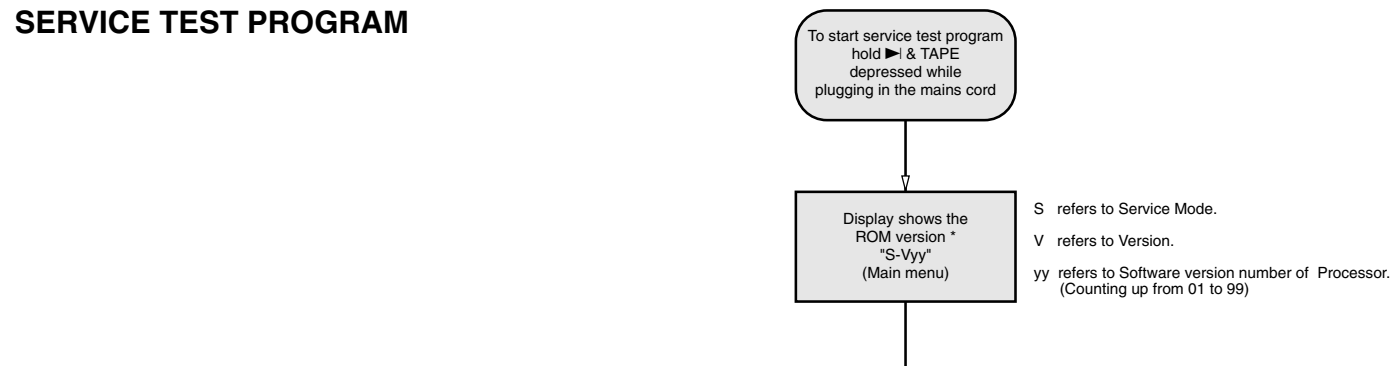

note 1: JAZZ & TECHNO are on while OPTIMAL is off, other LEDs status are not important (applicable only for sets with LEDs)
Figure 1

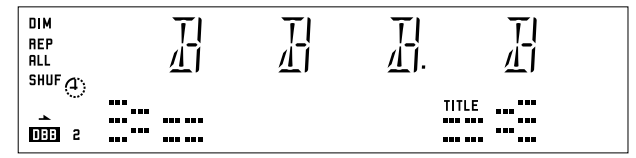

note 2: OPTIMAL is on while JAZZ & TECHNO are off, other LEDs status are not important (applicable only for sets with LEDs)
Figure 2

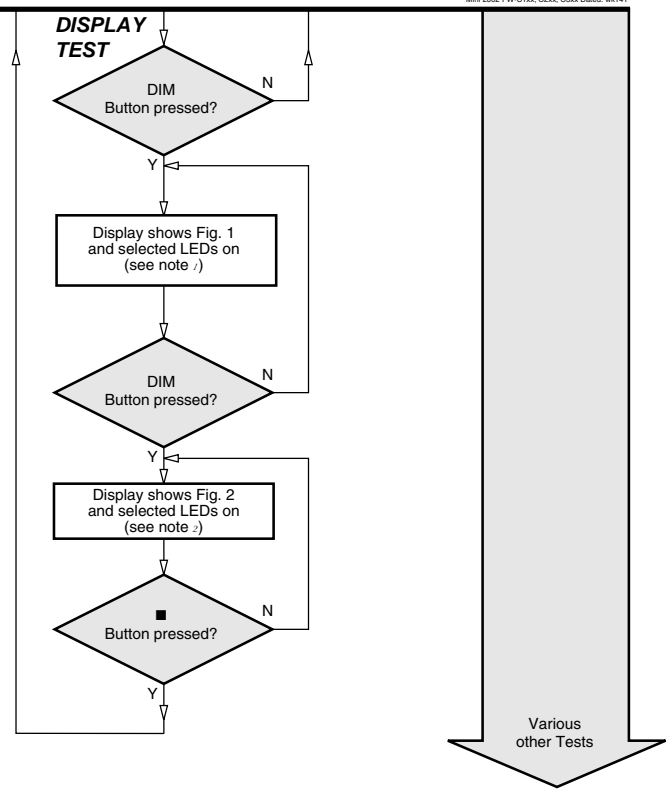

PRESET	Europe "EUR"	East Eur. Extended-band "EAS"	East Eur. "EAS"	USA "USA"	Oversea "OSE"
1	87.5MHz	65.81MHz	87.5MHz	87.5MHz	87.5MHz
2	108MHz	108MHz	108MHz	108MHz	108MHz
3	531kHz	74MHz	531kHz	530kHz	530/531kHz*
4	1602kHz	87.5MHz	1602kHz	1700kHz	1700/1602kHz*
5	558kHz	531kHz	558kHz	560kHz	560/558kHz*
6	1494kHz	1602kHz	1494kHz	1500kHz	1500/1494kHz*
7	87.5MHz	558kHz	87.5MHz	98MHz	98/87.5MHz*
8	87.5MHz	1494kHz	87.5MHz	87.5MHz	87.5MHz
9	87.5MHz	98MHz	87.5MHz	87.5MHz	87.5MHz
10	87.5MHz	70.01MHz	87.5MHz	87.5MHz	87.5MHz
11	98MHz	65.81MHz	98MHz	87.5MHz	87.5/98MHz*

Table 1

Note: * Depending on the selected grid frequency (9 or 10kHz)
By holding the TUNER and \blacktriangleleft buttons depressed while switching on the Mains supply, one of the undermentioned features will be activated:
- the tuning grid frequency is toggled between 9kHz and 10kHz for the Oversea (/21) version.
- the extended FM1 (65.81MHz - 74MHz) is toggled on and off for East Eur. (/34) version.

Error code	Error Description
E1000	Focus Error Triggered when the focus could not be found within a certain time when starting up the CD or when the focus is lost for a certain time during play.
E1001	Radial Error Triggered when the radial servo is off-track for a certain time during play.
E1002	Sledge In Error The sledge did not reach its inner position (inner-switch is still close) before approximately 6 Sec. have passed by. Inner-switch or sledge motor problem.
E1003	Sledge Out Error The sledge did not come out of its inner position (inner-switch is still open) before approximately 250 mSec. have passed by. Inner-switch or sledge motor problem.
E1005	Jump-offtrack error Triggered in normal play when the jump destination could not be found within a certain time. When this error occurred, software will try to recover by initiating the jump command again. If it is recoverable, the disc will continue to play.
E1006	Subcode Error Triggered when a new subcode was missing for a certain time during play.
E1007	PLL Error The Phase Lock Loop could not lock within a certain time.
E1008	Turntable Motor Error Generated when the CD could not reached 75% of speed during startup within a certain time. Discmotor problem.
E1020	Focus Search Error The focus point has not been found within a certain time.
E1070	This happens when the carousel switch is defective and closed all the time, or when the carousel is blocked when it is located exactly at a disc position.
E1071	This happens when the carousel switch is defective and does not closed electrically, or when the carousel is blocked in between two disc positions. The time-out is approximately 5 Sec.
E1079	The drawer could not open or enter the inside position and is opening again. This happen when the drawer is blocked and cannot go fully inside or when the drawer switch is defective and does not close.

Table 2

TEST	Activated with	ACTION
EEPROM TEST	\blacktriangleleft	A test pattern will be sent to the EEPROM. "PASS" is displayed if the uProcessor read back the test pattern correctly, otherwise "FAIL" will be displayed.
EEPROM FORMAT	\blacktriangleleft	Load default data. Display shows "NEW" for 1 second. Caution! All presets from the customer will be lost!!
ROTARY ENCODER TEST	Volume Knob or Jog Shuttle knob	Display shows value for 2 seconds. Values increases or decreases in steps of 1 until 0 (Min.) or 40 (Max.) is reached.
DEMO	DBB	DEMO will toggle on or off. The message: "DEMO ON" or "DEMO OFF" will scroll across the display to show the new status of the set.
LEAVE SERVICE TESTPROGRAM	Disconnect mains cord	

CIRCUIT DIAGRAM - KARAOKE PART

1800 A1	2428 A8	2803 B3	2806 B5	2809 E3	2812 E5	2815 E7	2818 E7	3801 A2	3804 A4	3807 B4	3810 A5	3813 C7	3816 E4	3819 E5	3822 E7	5800 B2	7411 A9	7802 E2	7805 E7
1801 B9	2801 B2	2804 A4	2807 A5	2810 E3	2813 E5	2816 E7	3423 A9	3802 B2	3805 A3	3808 B5	3811 B5	3814 E3	3817 E5	3820 E6	3823 D7	6800 E4	7800 B4	7803 E2	
1802 B8	2802 B3	2805 B5	2808 A6	2811 E4	2814 E6	2817 E7	3800 A2	3803 B3	3806 B4	3809 A5	3812 B6	3815 E3	3818 E5	3821 E6	3824 E7	6801 E4	7801 B6	7804 E5	

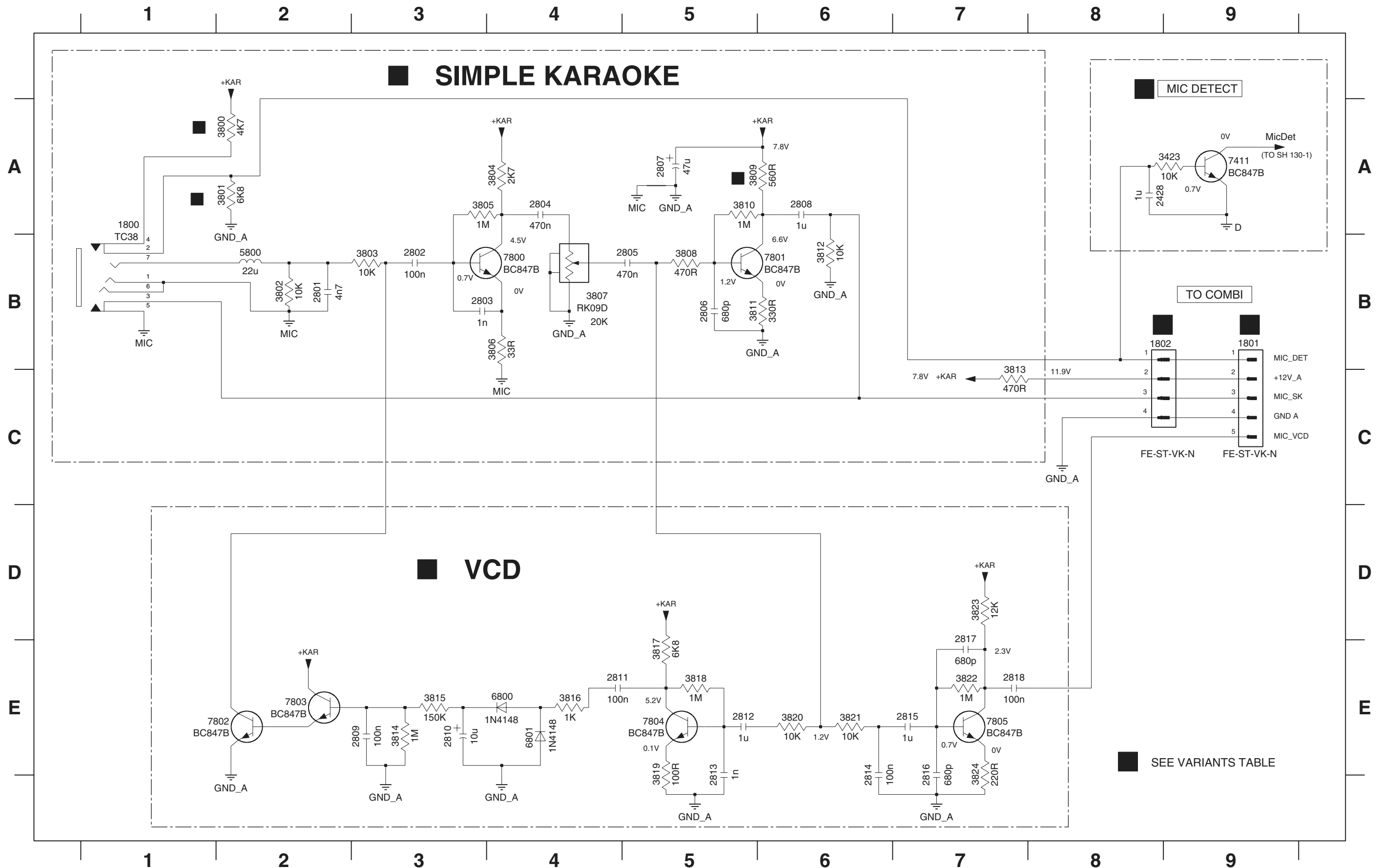

CIRCUIT DIAGRAM - MICROPROCESSOR PART

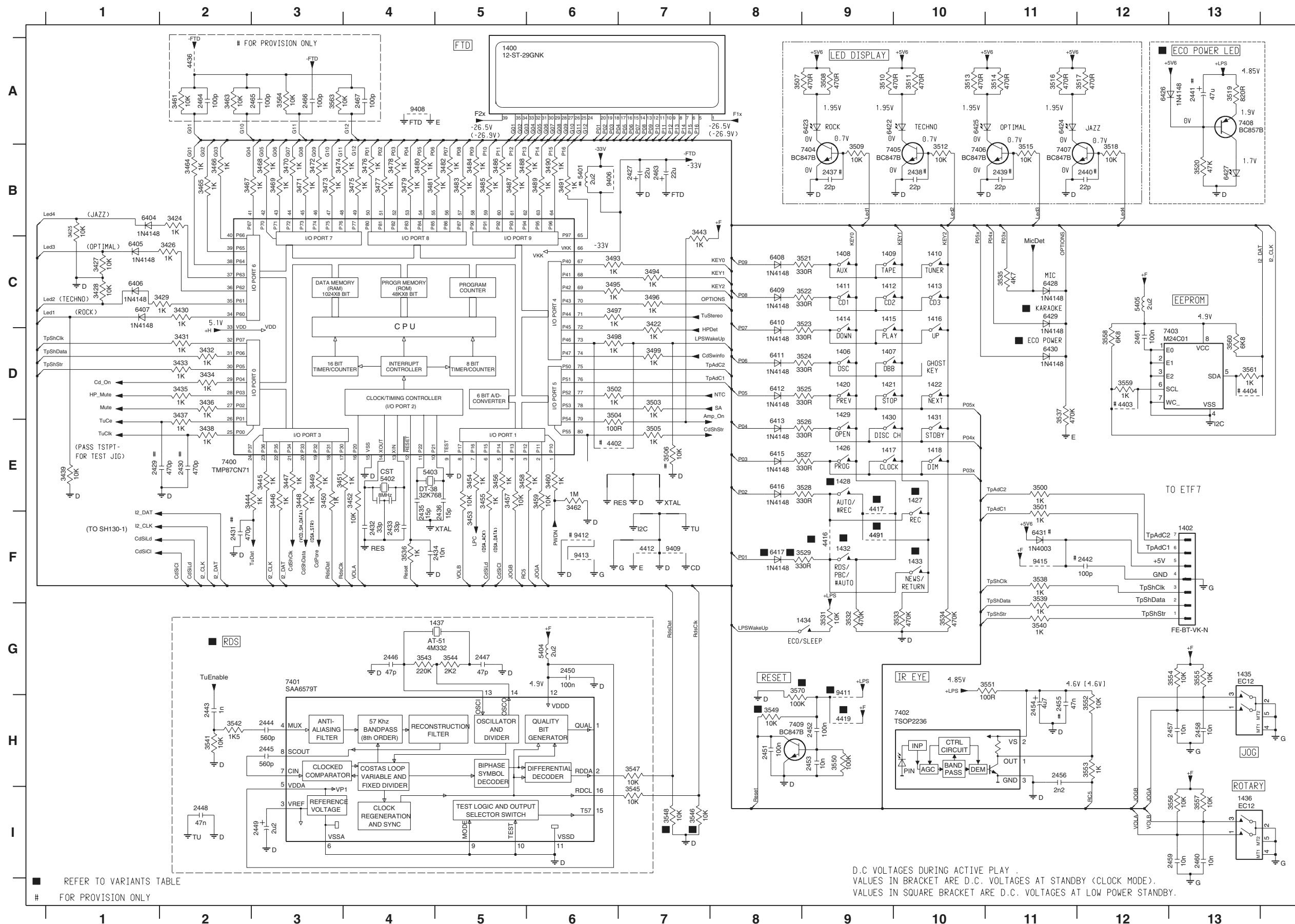

1400 A5	3471 B3	6412 D8
1402 F13	3472 B3	6413 E8
1406 D9	3473 B3	6415 E8
1407 D9	3474 B3	6416 E8
1408 C9	3475 B4	6417 F8
1409 C9	3476 B4	6422 A9
1410 C10	3477 B4	6423 A9
1411 C9	3478 B4	6424 A11
1412 C9	3479 B4	6425 A10
1413 C10	3480 B4	6426 A12
1414 C9	3481 B4	6427 B13
1415 C9	3482 B5	6428 C11
1416 C10	3483 B5	6429 C11
1417 E9	3484 B5	6430 D11
1418 E10	3485 B5	6431 F11
1420 D9	3486 B5	7402 H10
1421 D9	3487 B5	7403 D12
1422 D10	3488 B5	7404 B9
1426 E9	3489 B6	7405 B10
1427 E10	3490 B6	7406 B11
1428 E9	3491 B6	7407 B11
1429 D9	3493 C6	7408 A13
1430 E9	3494 C7	7409 H9
1431 E10	3495 C6	9406 B6
1432 F9	3496 C7	9408 A4
1433 F10	3497 C6	9409 F7
1434 G9	3498 D6	9411 H9
1435 G13	3499 D7	9412 F6
1436 H13	3500 E11	9413 F6
1437 G5	3501 E11	9415 F11
2427 B7	3502 D6	
2429 E1	3503 D7	
2430 E2	3504 D6	
2431 F2	3505 E7	
2432 F4	3506 E7	
2433 F4	3507 A8	
2434 F4	3508 A9	
2435 F4	3509 B9	
2436 F5	3510 A9	
2437 B9	3511 A10	
2438 B10	3512 B10	
2439 B11	3513 A10	
2440 B12	3514 A11	
2441 A13	3515 B11	
2442 F12	3516 A11	
2443 H2	3517 A12	
2444 H3	3518 B12	
2445 H3	3519 A13	
2446 G4	3520 B13	
2447 G5	3521 C9	
2448 I2	3522 C9	
2449 I3	3523 C9	
2450 G6	3524 D9	
2451 H8	3525 D9	
2452 H9	3526 E9	
2453 H9	3527 E9	
2454 H11	3528 E9	
2455 H11	3529 F9	
2456 H11	3531 G9	
2457 H13	3532 G9	
2458 H13	3533 C10	
2459 H13	3534 G10	
2460 H13	3535 C11	
2461 D12	3536 F4	
2463 B7	3537 D11	
2464 A2	3538 F11	
2465 A3	3539 F11	
2466 A3	3540 G11	
2467 A7	3541 H2	
3422 C7	3542 H2	
3424 B2	3543 G4	
3425 B1	3544 G5	
3426 C2	3545 I7	
3427 C1	3546 I7	
3428 C1	3547 H7	
3429 C2	3548 I7	
3430 C2	3549 H8	
3431 D2	3550 H9	
3432 D2	3551 G11	
3433 D2	3552 H12	
3434 D2	3553 H12	
3435 D2	3554 G13	
3436 D2	3555 G13	
3437 D2	3556 I3	
3438 E1	3557 I3	
3439 E1	3558 D12	
3443 B7	3559 D12	
3444 E2	3560 D13	
3445 E3	3561 D13	
3446 E3	3563 A3	
3447 E3	3564 A3	
3448 E3	3570 G8	
3449 E3	4402 E6	
3450 E3	4403 D12	
3451 E3	4404 D13	
3452 E4	4412 F7	
3453 F5	4416 F9	
3454 E5	4417 F9	
3455 E5	4419 H9	
3456 E5	4436 A2	
3457 E5	4491 F9	
3458 E5	5401 B6	
3459 E6	5402 E4	
3460 E6	5403 E4	
3461 A2	5404 G6	
3462 E6	5405 C12	
3463 A2	6404 B1	
3464 B2	6405 C1	
3465 B2	6406 C1	
3466 B2	6407 C1	
3467 B2	6408 C8	
3468 B3	6409 C8	
3469 B3	6410 C8	
3470 B3	6411 D8	

D.C. VOLTAGES DURING ACTIVE PLAY .
 VALUES IN BRACKET ARE D.C. VOLTAGES AT STANDBY (CLOCK MODE).
 VALUES IN SQUARE BRACKET ARE D.C. VOLTAGES AT LOW POWER STANDBY.

■ REFER TO VARIANTS TABLE
 # FOR PROVISION ONLY

CIRCUIT DIAGRAM - HEADPHONE / MISCELLANEOUS PART

1438 A1	2400 F4	2404 B7	2408 B9	2412 A4	2416 A4	2420 A6	2424 F3	2600 D8	2606 F9	3402 B9	3408 F4	3413 A3	3417 C3	3421 C8	3567 B8	3601 E6	3605 F7	4406 F4	4410 B5	4418 B3	5400 A7	6400 A7	6600 F7	7602 F6	9410 C5	9514 F4
1439 A1	2401 A7	2405 B7	2409 B9	2413 C3	2417 A4	2421 F2	2425 C7	2601 E8	2610 E7	3405 F5	3410 A2	3414 C2	3418 C7	3492 F4	3568 B9	3602 D8	4400 E4	4407 F3	4411 D5	4459 F2	5600 D7	6401 A7	6601 F7	9401 A9	9416 B5	
1600 E9	2402 A7	2406 A9	2410 F5	2414 A4	2418 A4	2422 F2	2426 C8	2602 F8	2611 E7	3406 E5	3411 A2	3415 C2	3419 C7	3565 A8	3569 E5	3603 D8	4401 E5	4408 C4	4414 E5	4487 A5	5601 E7	6402 B7	7600 E7	9402 A9	9488 F4	
1601 F9	2403 A7	2407 A9	2411 F5	2415 A4	2419 A5	2423 F3	2470 B6	2603 F7	3400 A9	3407 E4	3412 A3	3416 C3	3420 C7	3566 A9	3600 E6	3604 F7	4405 F5	4409 E4	4415 A5	4490 E4	5602 E8	6420 C7	7601 E7	9404 D5	9506 F3	

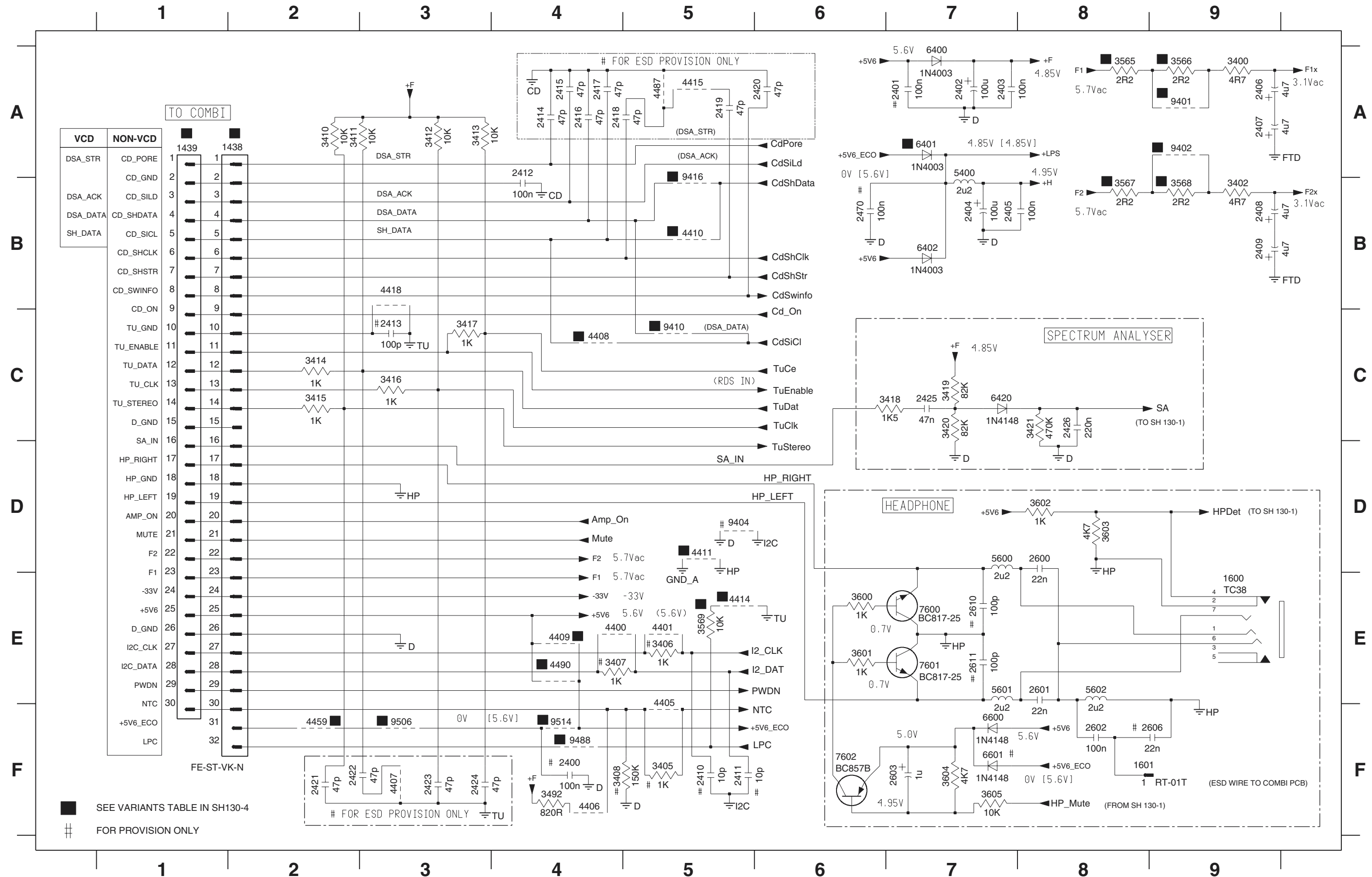

MAINS CIRCUIT

1201 A3	1207 C5	1211 E6	2203 A8	2207 A6	2211 B9	2215 B9	3205 A9	3209 B1	3216 B1	3221 A2	5201 A4	5206 C1	6204 A10	6208 A8	6212 B9	6216 B6	7201 A6	7205 B7	9202 C1	9206 E2
1204 C3	1208 D1	1212 E5	2204 A9	2208 A3	2212 B10	3202 A6	3206 A5	3212 B2	3217 D1	3222 A10	5202 A8	6201 A5	6205 A6	6209 A9	6213 B10	6217 A1	7202 A7	7206 B1	9203 C2	9207 A3
1205 C2	1209 C6	2201 A9	2205 A6	2209 A6	2213 B3	3203 A7	3207 A5	3214 B6	3218 A2	3224 B3	5203 A4	6202 A5	6206 A5	6210 A3	6214 B5	6218 A1	7203 B2	8201 E1	9204 D1	
1206 C1	1210 E2	2202 A4	2206 A4	2210 A8	2214 B8	3204 A7	3208 B6	3215 B8	3220 A2	3230 B7	5204 B5	6203 A10	6207 A3	6211 A5	6215 B2	6219 A2	7204 B5	9201 C3	9205 E2	

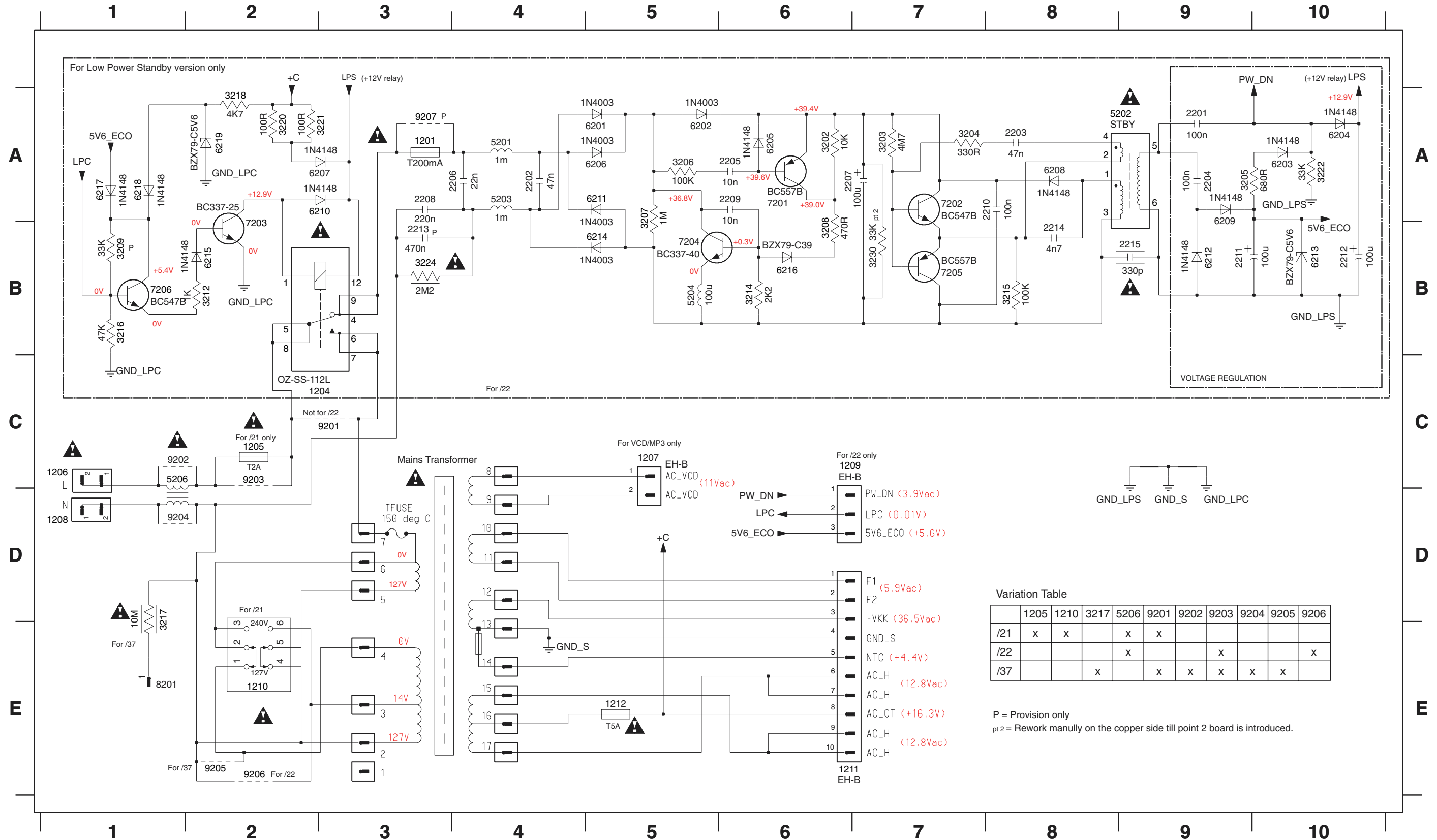

Variation Table

	1205	1210	3217	5206	9201	9202	9203	9204	9205	9206
/21	x	x		x	x					
/22				x			x			x
/37			x		x	x	x	x	x	

P = Provision only
 pt 2 = Rework manually on the copper side till point 2 board is introduced.

ANALOG CIRCUIT

1701 F9	2705 A2	2712 B6	2719 C5	2726 D4	2735 B3	2745 F5	2765 B4	2785 F1	3705 A4	3712 B4	3719 C6	3726 D5	3733 A2	3744 F8	3753 F5	3760 A7	3767 A7	3774 E3	3781 D2	4794 C6	6774 D3	6786 B7	7782 E1	9791 A8
1710 C1	2706 A2	2713 A6	2720 D5	2727 A3	2737 A6	2746 F8	2769 F7	2786 D1	3706 B4	3713 A7	3720 E6	3727 A7	3734 B2	3745 F8	3754 E8	3761 E3	3768 E8	3775 F3	3784 D1	5701 D2	6775 C3	6787 A3	7783 E2	9792 B8
1730 A1	2707 A4	2714 B6	2721 C5	2728 E5	2738 B6	2747 E8	2770 F8	2787 D3	3707 A5	3714 B7	3721 C6	3728 B7	3735 A2	3746 E8	3755 E7	3762 E2	3769 E4	3776 F2	3786 F4	5703 F1	6776 F3	6788 A5	7784 D2	9793 A6
2701 B2	2708 B4	2715 A4	2722 D5	2729 A8	2741 D6	2760 E3	2780 F3	3701 B1	3708 B4	3715 A6	3722 D6	3729 A7	3736 B1	3748 C8	3756 D8	3763 A5	3770 F2	3777 F2	3787 C3	6770 E2	6777 E2	7730 D6	7786 C2	
2702 B2	2709 A5	2716 C4	2723 C5	2730 B8	2742 C3	2761 B5	2781 F2	3702 C2	3709 A4	3716 B6	3723 A3	3730 B7	3741 A6	3749 C7	3757 D8	3764 A5	3771 F2	3778 E1	3788 C3	6771 E2	6778 E4	7740 A8	7787 C8	
2703 A2	2710 B5	2717 C6	2724 D5	2733 A5	2743 F1	2762 B6	2782 F2	3703 A2	3710 C4	3717 C6	3724 D5	3731 A7	3742 C7	3751 E5	3758 D8	3765 B6	3772 F3	3779 D3	3789 F4	6772 D1	6782 C7	7780 F4	7791 F5	
2704 B2	2711 A6	2718 D6	2725 D4	2734 C4	2744 A4	2763 B6	2784 F1	3704 B1	3711 A5	3718 E6	3725 C5	3732 B7	3743 F8	3752 F4	3759 D7	3766 B7	3773 E3	3780 D2	4790 C3	6773 D1	6785 A7	7781 F3	7792 D8	

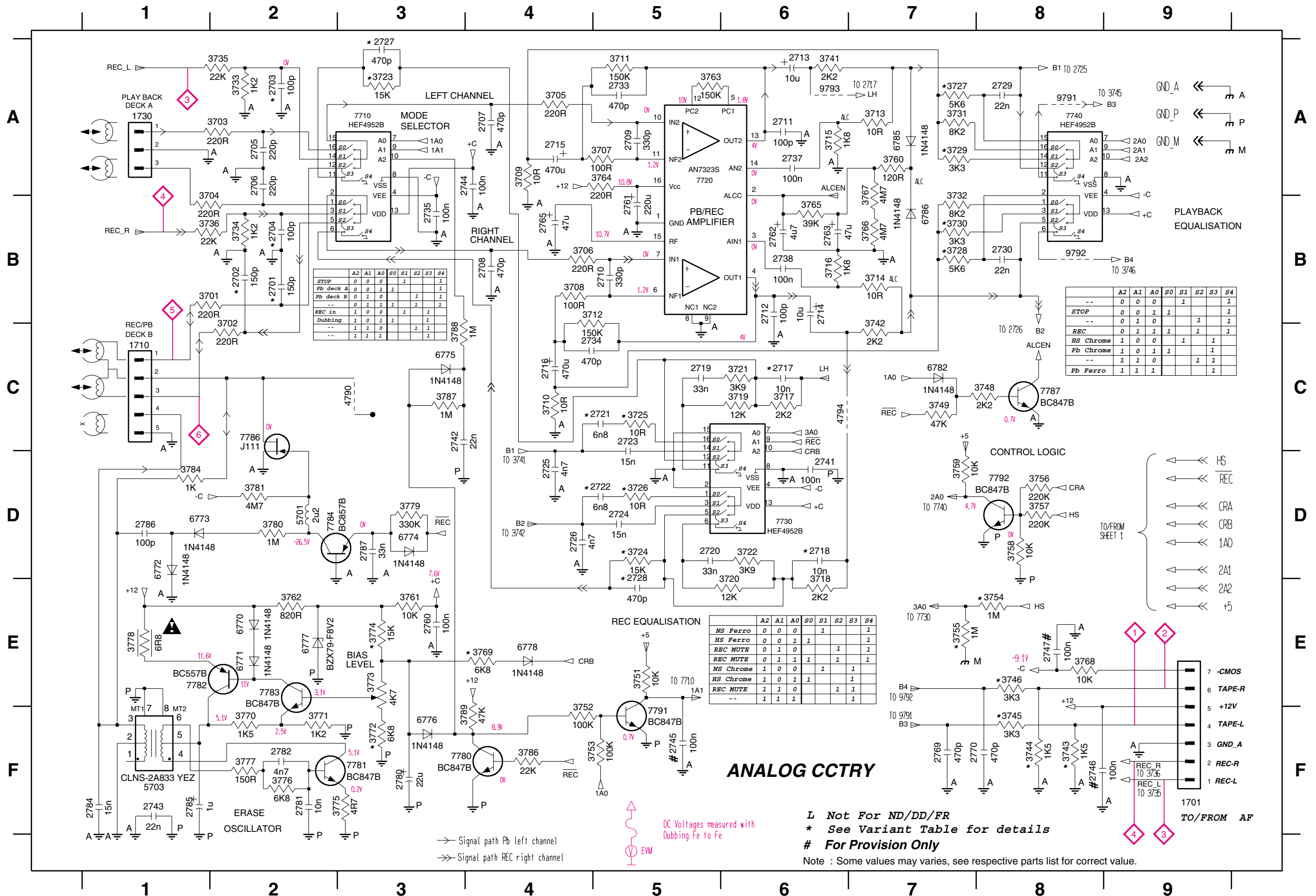

SERVO CONTROL CIRCUIT

1702 A7	1760 B8	2622 D2	2625 E4	3601 B2	3604 C2	3607 C6	3610 D6	3613 B2	3618 A4	3622 A4	3625 B3	3630 A6	3676 C5	3680 C5	3687 D2	4785 D2	6612 B6	7612 A6	7616 A4	7620 B6	7624 D6
1703 B1	1770 B7	2623 D2	2626 B1	3602 C2	3605 B3	3608 D6	3611 C6	3614 C6	3619 A4	3623 B3	3626 B6	3672 B4	3678 B5	3685 D2	3688 A5	4795 E3	6614 B4	7613 A3	7618 B6	7622 B5	9705 A7
1706 E1	2621 D2	2624 E2	2627 A7	3603 B2	3606 C3	3609 C6	3612 D6	3616 A5	3620 A4	3624 B6	3628 A5	3674 B5	3679 B3	3686 E6	3689 E3	6611 A2	7610 D4	7614 A6	7619 B4	7623 D2	

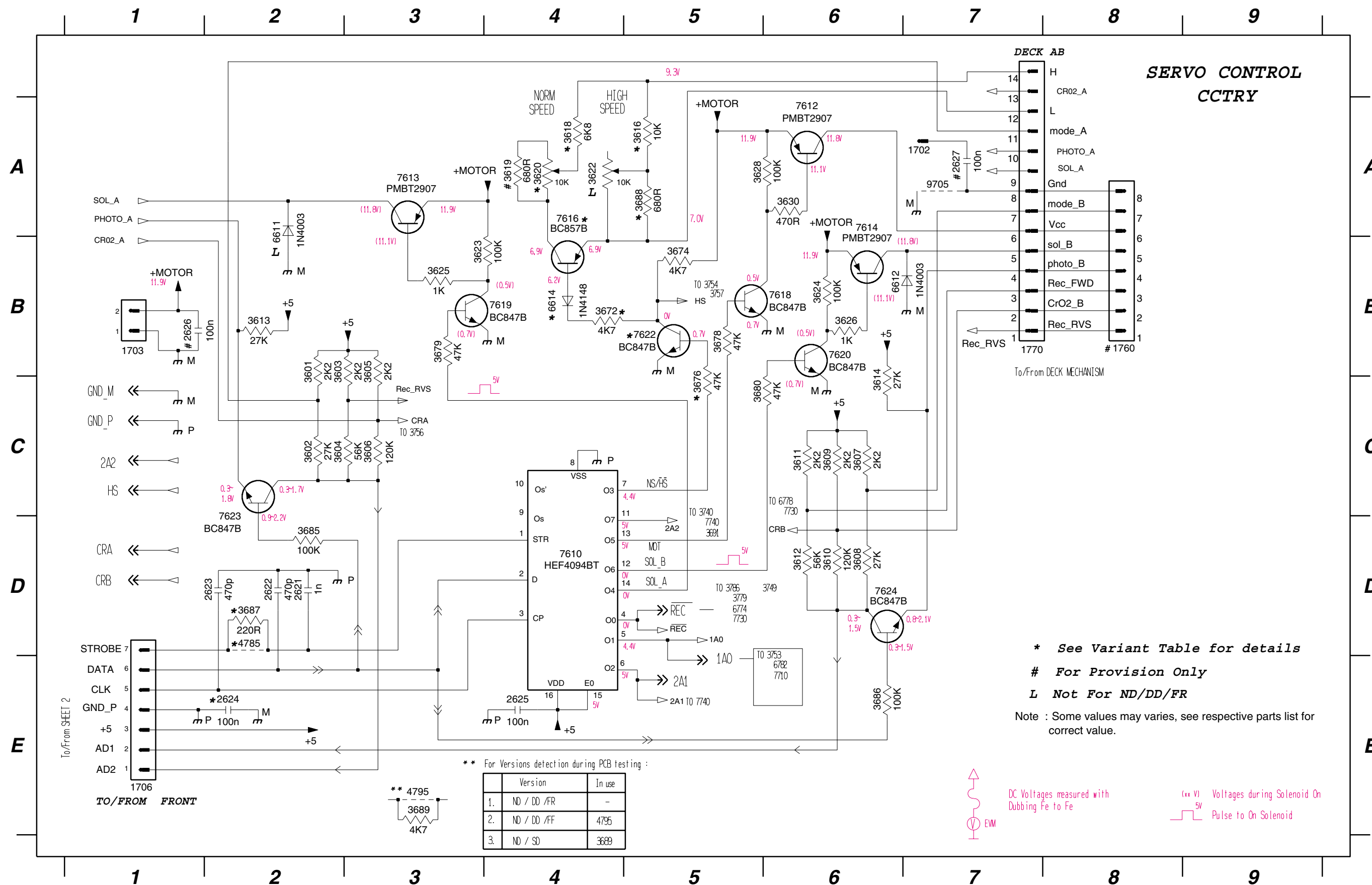

1800 F1	2804 D4	2811 A9	2818 B11	2826 G12	2838 D8	2851 B11	2888 C4	3702 D3	3721 D6	3792 F8	3800 D8	3807 B9	3819 D14	3828 G11	3839 H6	3846 F5	3863 G13	3895 G12	7803-B D5	MP713 C9	MP743 D2	MP813 B3	MP820 F8	MP837 D4	MP844 E9	MP851 E2	MP873 H4	MP884 C5
1801 G1	2805 C8	2812 D5	2819 E5	2828 G13	2839 F4	2855 C8	2891 F4	3703 D3	3723 E6	3793 E8	3801 D8	3808 A9	3820 C3	3832 C15	3840 G5	3847 F5	3867 A11	3896 E9	7806 G3	MP715 D9	MP744 C2	MP814 G2	MP821 C15	MP838 G6	MP845 F4	MP852 G2	MP875 F13	MP893 F10
1810 B10	2806 B8	2813 F7	2820 D4	2833 B10	2840 G4	2856 D15	2894 F8	3704 D4	3724 D6	3794 F7	3802 C8	3811 C8	3821 B3	3833 A8	3841 G5	3849 H5	3870 E2	3900 F9	7807 H3	MP716 B9	MP745 E2	MP815 B3	MP827 B10	MP839 G6	MP846 H2	MP853 G2	MP876 E2	
2800 D8	2807 B8	2814 F7	2822 F9	2834 B10	2841 F5	2857 H5	2895 G12	3709 C14	3725 D6	3795 F8	3803 C8	3812 H4	3822 B3	3834 B8	3842 E6	3850 H5	3873 D14	3901 D4	7808 F7	MP717 A9	MP800 E2	MP816 A3	MP828 G11	MP840 E6	MP847 H2	MP858 G8	MP877 E3	
2801 D8	2808 B9	2815 B8	2823 F10	2835 H7	2842 E5	2869 D3	2896 H12	3710 B8	3789 F8	3796 F8	3804 C14	3813 E2	3825 F9	3835 F5	3843 E5	3852 H5	3889 D15	3904 G10	7809 G8	MP729 B9	MP802 B15	MP817 A3	MP829 A3	MP841 F6	MP848 E2	MP859 E10	MP878 B13	
2802 C8	2809 H4	2816 B12	2824 F10	2836 E10	2844 F5	2885 E9	2897 H12	3719 D4	3790 F7	3798 D8	3805 B8	3815 C4	3826 F9	3837 G7	3844 E5	3853 E9	3892 E15	7802 D3	7810 F9	MP730 C9	MP809 D10	MP818 C4	MP831 A4	MP842 H6	MP849 E2	MP860 C2	MP879 B11	
2803 C8	2810 A8	2817 F7	2825 E9	2837 H4	2850 C14	2887 B10	3701 D3	3720 D5	3791 E7	3799 D8	3806 C8	3818 B3	3827 E10	3838 H7	3845 F6	3862 A10	3894 E9	7803-A B5	7877 D12	MP731 B13	MP812 G2	MP819 F10	MP836 D3	MP843 G7	MP850 E2	MP872 C15	MP883 C4	

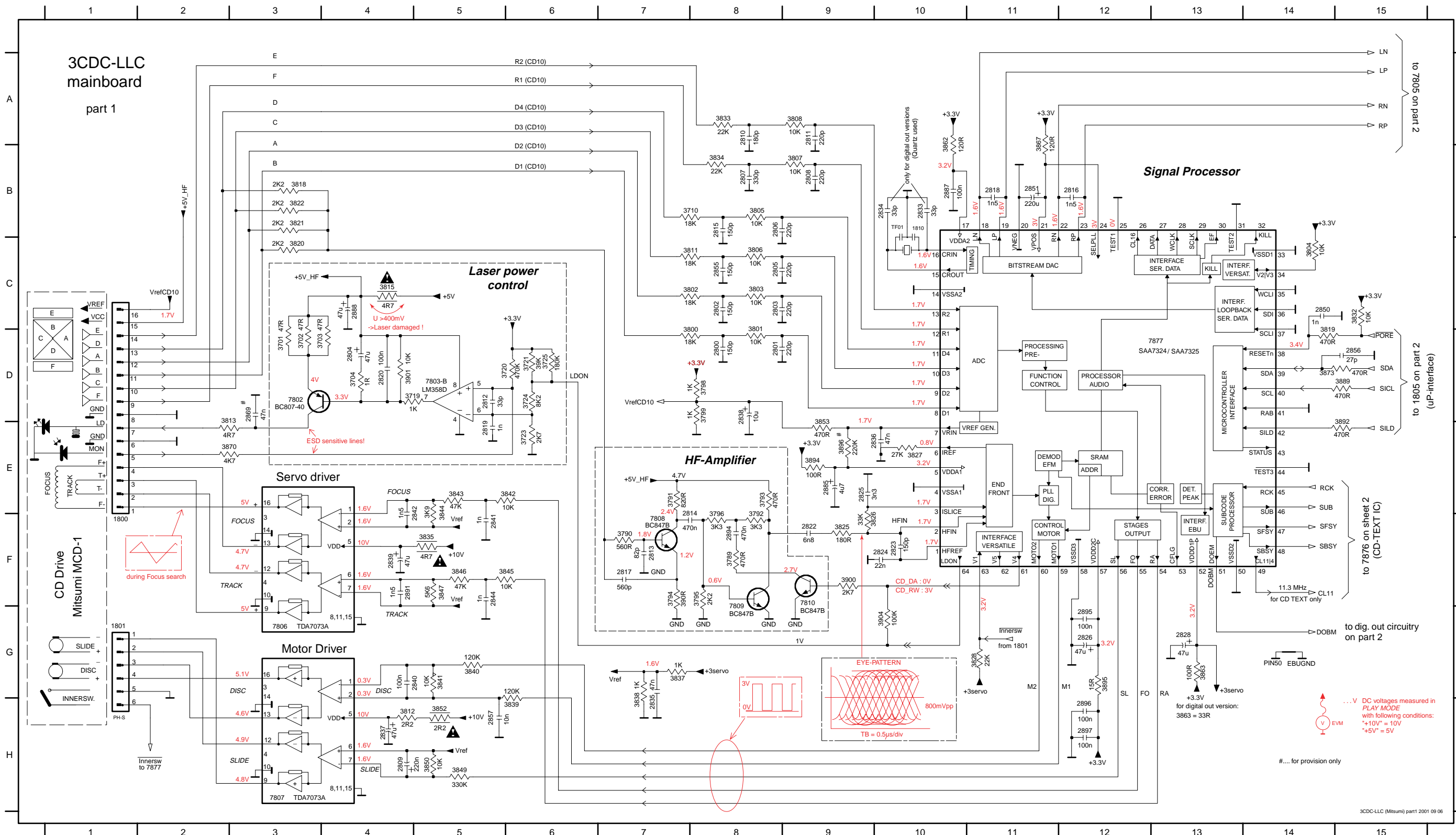

... V DC voltages measured in PLAY MODE with following conditions:
 +10V = 10V
 +5V = 5V

#.... for provision only

1805 E15	2830 C9	2858 A9	2865 C4	2877 F11	3705 G4	3713 G8	3730 G2	3741 A7	3751 C7	3851 D7	3865 A10	3874 C13	3880 E6	3886 E7	3898 F7	4876 D13	6875 F7	7805-B A8	7876 G3	MP726 D8	MP804 G14	MP811 F14	MP832 G9	MP863 C11	MP871 D6	MP888 G5	MP898 E13	
1875 D2	2831 B9	2860 A11	2867 A8	2878 F11	3706 G4	3714 F8	3731 G2	3742 B7	3752 A6	3858 A11	3866 A10	3875 C12	3881 E7	3887 D6	3899 D12	5802 B4	6876 D13	7812 G8	7812 G8	MP721 C8	MP740 H14	MP805 F13	MP822 E3	MP865 D11	MP874 D12	MP889 G5	MP899 E14	
1878 E2	2832 A8	2861 B11	2872 G10	2881 F8	3707 G4	3715 G8	3732 G2	3743 B7	3753 A6	3859 B11	3868 B10	3876 C11	3882 D7	3888 F12	3905 C5	6871 F8	6877 D12	7871 C5	7871 C5	MP722 E8	MP742 G14	MP806 F13	MP823 E3	MP835 F14	MP866 E8	MP881 G2	MP890 B3	
1880 F8	2852 H2	2862 B8	2873 D6	2882 B10	3708 H4	3716 B3	3733 G2	3744 A9	3809 B2	3860 B7	3869 B10	3877 F12	3883 D6	3890 F11	4803 B4	6872 E8	6878 E8	6878 E8	7873 D10	7873 D8	MP723 D8	MP742 G14	MP807 F14	MP824 D4	MP854 A13	MP867 E8	MP882 G2	MP891 B5
1881 E8	2853 G4	2863 B8	2875 E6	2883 F12	3711 G5	3717 B3	3734 H2	3746 B10	3814 D12	3861 B8	3871 F12	3878 E12	3884 D6	3891 F11	4811 A7	6873 E8	6879 G4	7874 C12	7874 C12	MP724 D8	MP801 E12	MP808 F13	MP825 D4	MP856 E14	MP868 F8	MP886 G3	MP892 B5	
2829 D6	2854 B3	2864 B3	2876 C7	3700 H2	3712 B4	3718 G3	3740 A7	3750 B7	3831 G4	3864 A7	3872 C13	3879 D7	3885 D6	3893 F11	4812 B7	6874 G7	7805-A B9	7875 D12	7875 D12	MP725 D8	MP803 F10	MP810 F13	MP830 A7	MP857 B13	MP869 C12	MP887 H5	MP897 E13	

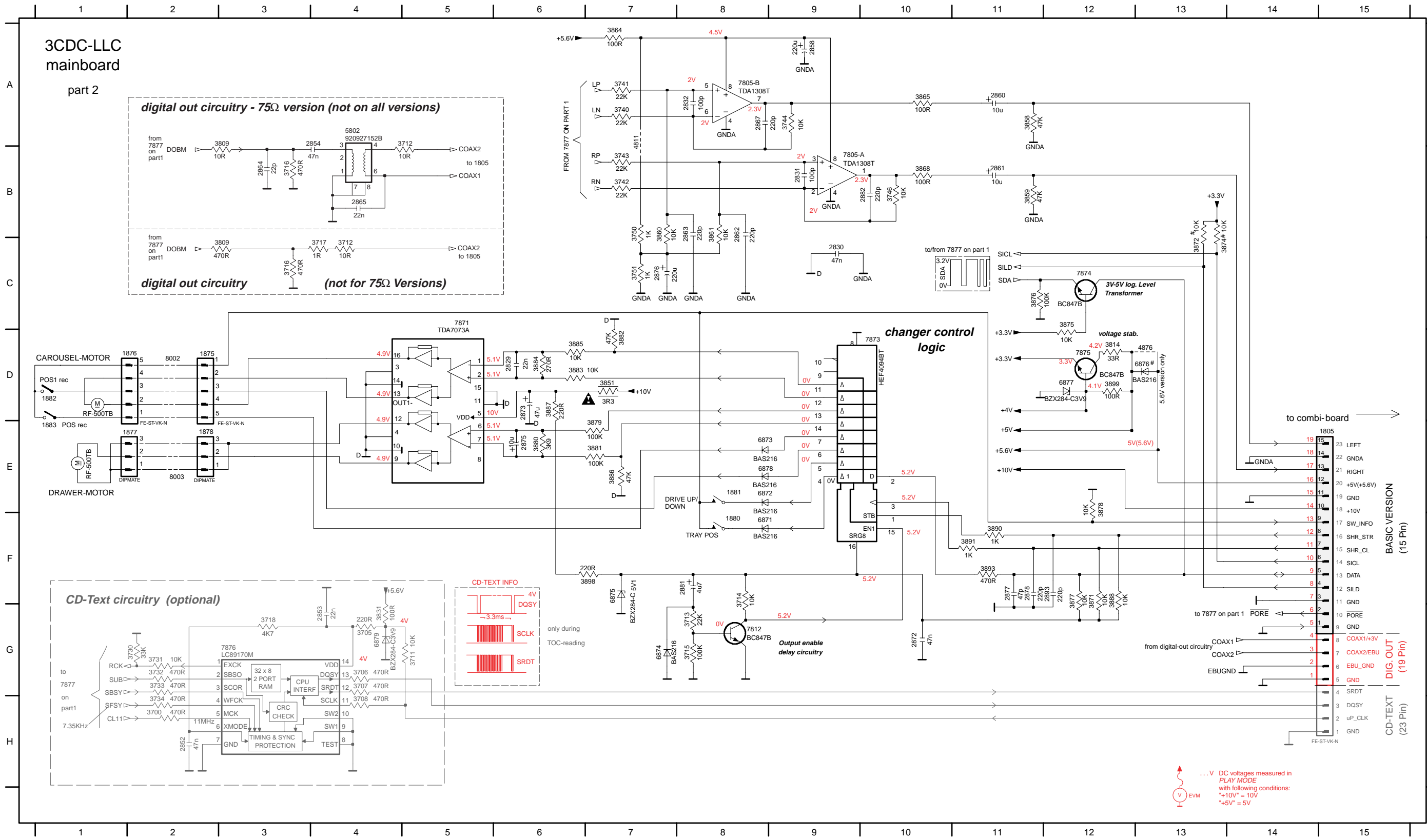

... V DC voltages measured in PLAY MODE with following conditions:
 +10V = 10V
 +5V = 5V

POWER SUPPLY CIRCUIT

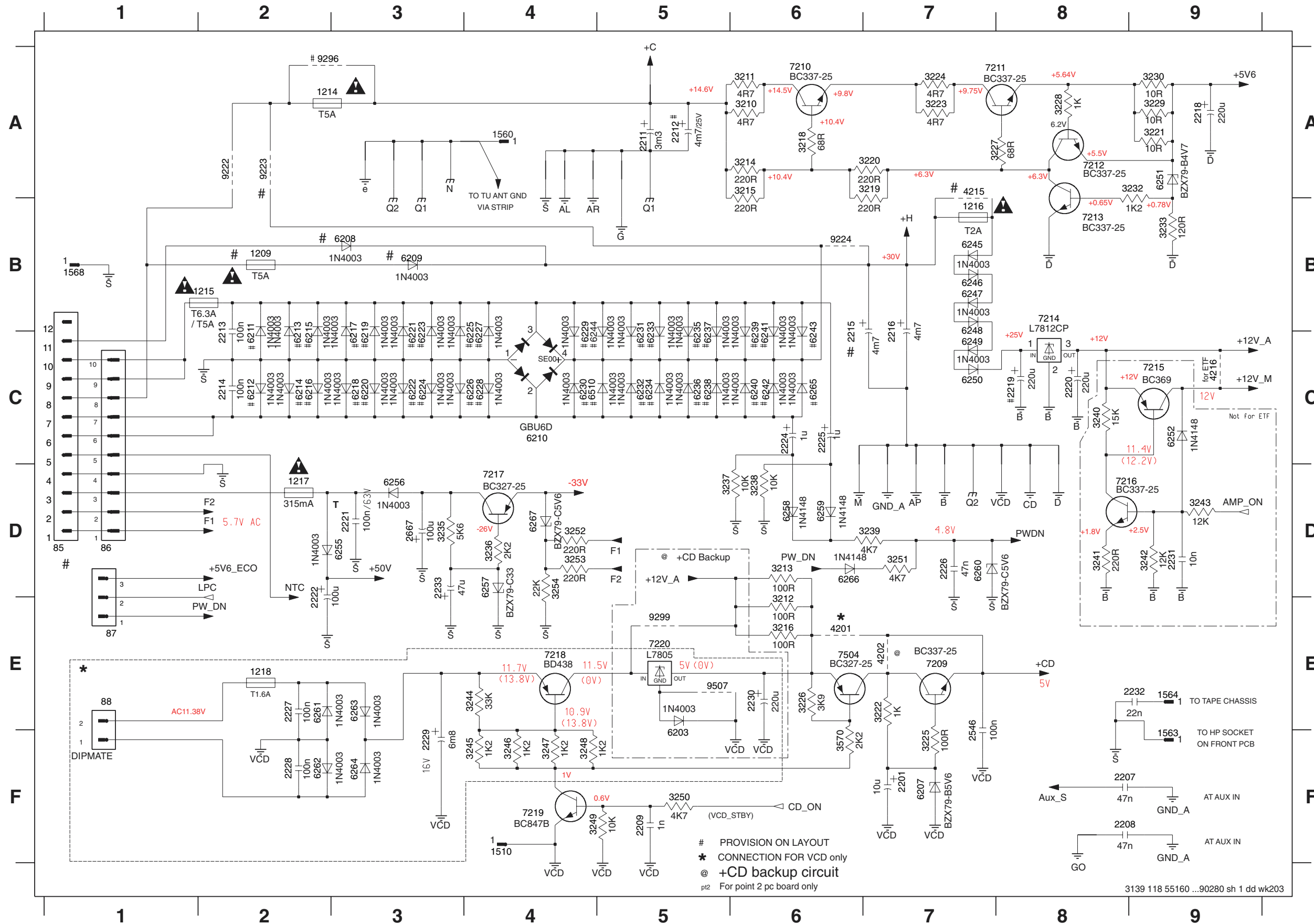

85 D1	3252 D4	9222 A2
86 D1	3253 D4	9223 A2
87 E1	3254 D4	9224 B6
88 E1	3570 F6	9296 A2
1209 B2	4201 E6	9299 E5
1214 A2	4202 E7	9507 E5
1215 B2	4215 A7	
1216 B7	4216 C9	
1217 D2	6203 E5	
1218 E2	6207 F7	
1510 F4	6208 B3	
1560 A4	6209 B3	
1563 F9	6210 C4	
1564 E9	6211 C2	
1568 B1	6212 C2	
2201 F7	6213 C2	
2207 F8	6214 C2	
2208 F8	6215 C2	
2209 F5	6216 C2	
2211 A5	6217 C3	
2212 A5	6218 C3	
2213 C2	6219 C3	
2214 C2	6220 C3	
2215 C6	6221 C3	
2216 C7	6222 C3	
2218 A9	6223 C3	
2219 C8	6224 C3	
2220 C8	6225 C4	
2221 D3	6226 C4	
2222 E2	6227 C4	
2224 C6	6228 C4	
2225 C6	6229 C4	
2226 D7	6230 C4	
2227 E2	6231 C5	
2228 F2	6232 C5	
2229 F3	6233 C5	
2230 E6	6234 C5	
2231 D9	6235 C5	
2232 E9	6236 C5	
	6237 C5	
2233 D3	6238 C5	
2546 F7	6239 C6	
2667 D3	6240 C6	
3210 A6	6241 C6	
3211 A6	6242 C6	
3212 E6	6243 C6	
3213 D6	6244 C4	
3214 A6	6245 B7	
3215 A6	6246 B7	
3216 E6	6247 B7	
3218 A6	6248 B7	
3219 A7	6249 C7	
3220 A7	6250 C7	
3221 A9	6251 A9	
3222 E7	6252 C9	
3223 A7	6255 D3	
3224 A7	6256 D3	
3225 F7	6257 D4	
3226 E6	6258 D6	
3227 A8	6259 D6	
3228 A8	6260 D7	
3229 A9	6261 E2	
3230 A9	6262 F2	
3232 A9	6263 E3	
3233 B9	6264 F3	
3235 D3	6265 C6	
3236 D4	6266 D6	
3237 D5	6267 D4	
3238 D6	6510 C4	
3239 D7	7209 E7	
3240 C8	7210 A6	
3241 D8	7211 A7	
3242 D9	7212 A8	
3243 D9	7213 B8	
3244 E4	7214 B8	
3245 F4	7215 C9	
3246 F4	7216 D8	
3247 F4	7217 D4	
3248 F4	7218 E4	
3249 F4	7219 F4	
3250 F5	7220 E5	
3251 D7	7504 E6	

SOURCE SELECTION CIRCUIT

C3 E15	C10 C14	1501 D1	1507 C13	2504 B4	2510 D4	2516 G8	2522 G7	2528 F7	2534 H10	2540 G11	2549 E15	2568 D15	2665 G5	3505 B3	3511 D3	3517 E2	3523 C6	3534 H9	3540 H11	3563 E12	3605 A8	6502 D6	7601 B8	9602 D15
C4 E15	C11 A3	1502 D2	1508 E14	2505 B4	2511 F2	2517 G6	2523 E7	2529 D9	2535 C10	2541 C11	2560 F12	2570 C1	2666 G8	3506 B3	3512 E3	3518 F2	3524 F7	3535 D9	3541 D11	3564 F12	3606 B8	6503 D12	7609 B9	9603 E15
C5 D15	C13 A3	1503 G1	1509 H1	2506 C4	2512 F2	2518 G7	2524 C6	2530 G9	2536 H10	2542 G11	2561 F12	2601 A8	3507 B3	3513 E3	3519 E3	3525 F7	3536 G9	3542 H11	3561 A7	3607 A8	6504 D13	7609 B9	9603 E15	
C6 C15	C14 C15	1504 F1	2501 A4	2507 C4	2513 E4	2519 G6	2525 D6	2531 C9	2537 D10	2543 D15	2562 E12	2601 A8	3508 C3	3514 D3	3520 F3	3531 C8	3537 C9	3543 B2	3602 B7	4501 G5	6509 C1	7501 D8	9599 A3	
C7 C15	T_E D14	1505 G2	2502 A4	2508 D4	2514 F3	2520 G7	2526 C7	2532 H9	2538 G10	2547 E12	2564 G12	2602 B7	3509 C3	3515 E3	3521 H9	3532 H9	3538 H9	3560 E12	3603 A9	5305 D15	6501 D8	7501 D8	9600 A3	
C8 C15	1500 A1	1506 H1	2503 B4	2509 E4	2515 G6	2521 G6	2527 E7	2533 C10	2539 C11	2548 H2	2567 C8	2603 A8	3504 A4	3510 D3	3516 E4	3522 F3	3533 C9	3539 D11	3561 F12	3604 A8	5501 A2	6502 D6	7501 D8	

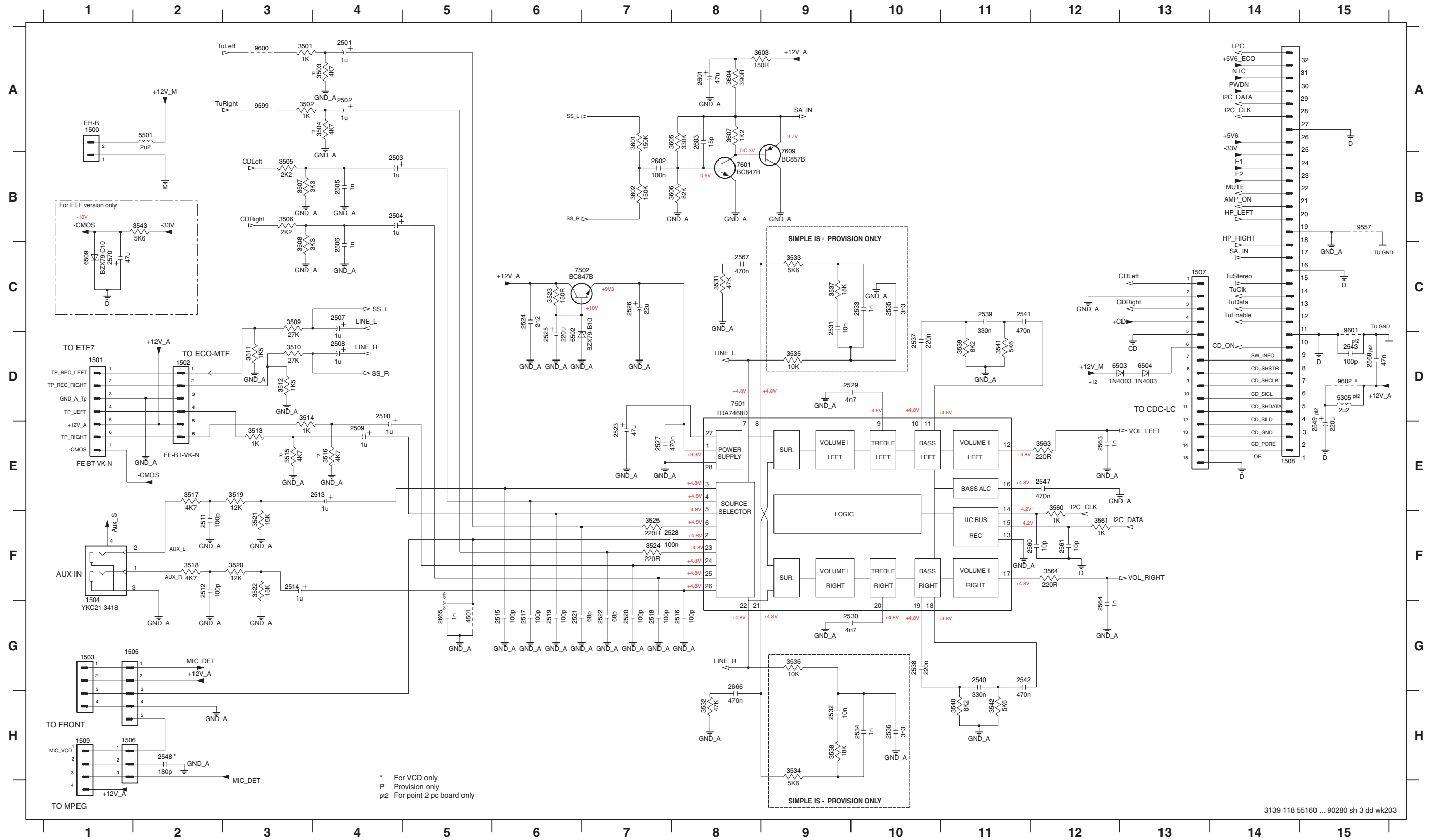

* For VCD only
P Provision only
p2 For point 2 pc board only

PRE- & POWER AMPLIFIER CIRCUIT

0888 E13	1323 E14	2365 E12	2370 F13	2378 E12	2608 D2	2613 G1	2618 E4	3356 E14	3361 E7	3366 F12	3371 E12	3377 B10	3386 C13	3392 C8	3612 D4	3617 B5	3622 G1	3627 E4	3632 A1	5301 D12	6371 B9	6376 E11	7301 E9	7600-B D3	7606 E4
0889 G13	2351 D14	2366 F12	2371 C7	2604 C2	2609 A3	2614 G2	2662 A1	3357 E14	3362 F7	3367 D12	3372 E12	3378 B10	3387 D10	3608 E2	3613 B5	3618 C5	3623 E1	3628 E4	3633 D1	5302 G12	6372 B8	6377 E11	7302 C9	7602 D4	7607 E5
1300-A F13	2352 F14	2367 D12	2372 D8	2605 A2	2610 D3	2615 E2	2663 D1	3358 F14	3363 E7	3368 G12	3373 E12	3379 D10	3388 D10	3609 A4	3614 D5	3619 B5	3624 F3	3629 F5	3634 B2	5303 E12	6373 C8	6378 F12	7303 C10	7603 B5	7608 B4
1300-B E13	2361 E7	2368 F13	2373 C10	2606 D2	2611 B6	2616 E2	2664 A2	3359 E14	3364 E7	3369 D12	3374 E11	3384 B13	3389 C9	3610 D4	3615 A5	3620 C5	3625 F3	3630 A1	3635 B2	5304 F12	6374 C10	6379 E12	7304 C10	7604 D5	9508 G14
1322 E14	2362 E7	2369 E12	2377 C14	2607 B2	2612 D6	2617 F4	3355 D14	3360 F14	3365 D12	3370 F12	3376 C9	3385 C14	3390 C9	3611 B4	3616 D5	3621 F1	3626 E4	3631 C1	3636 E2	5601 E2	6375 C11	6380 D11	7600-A A2	7605 F4	9510 D14

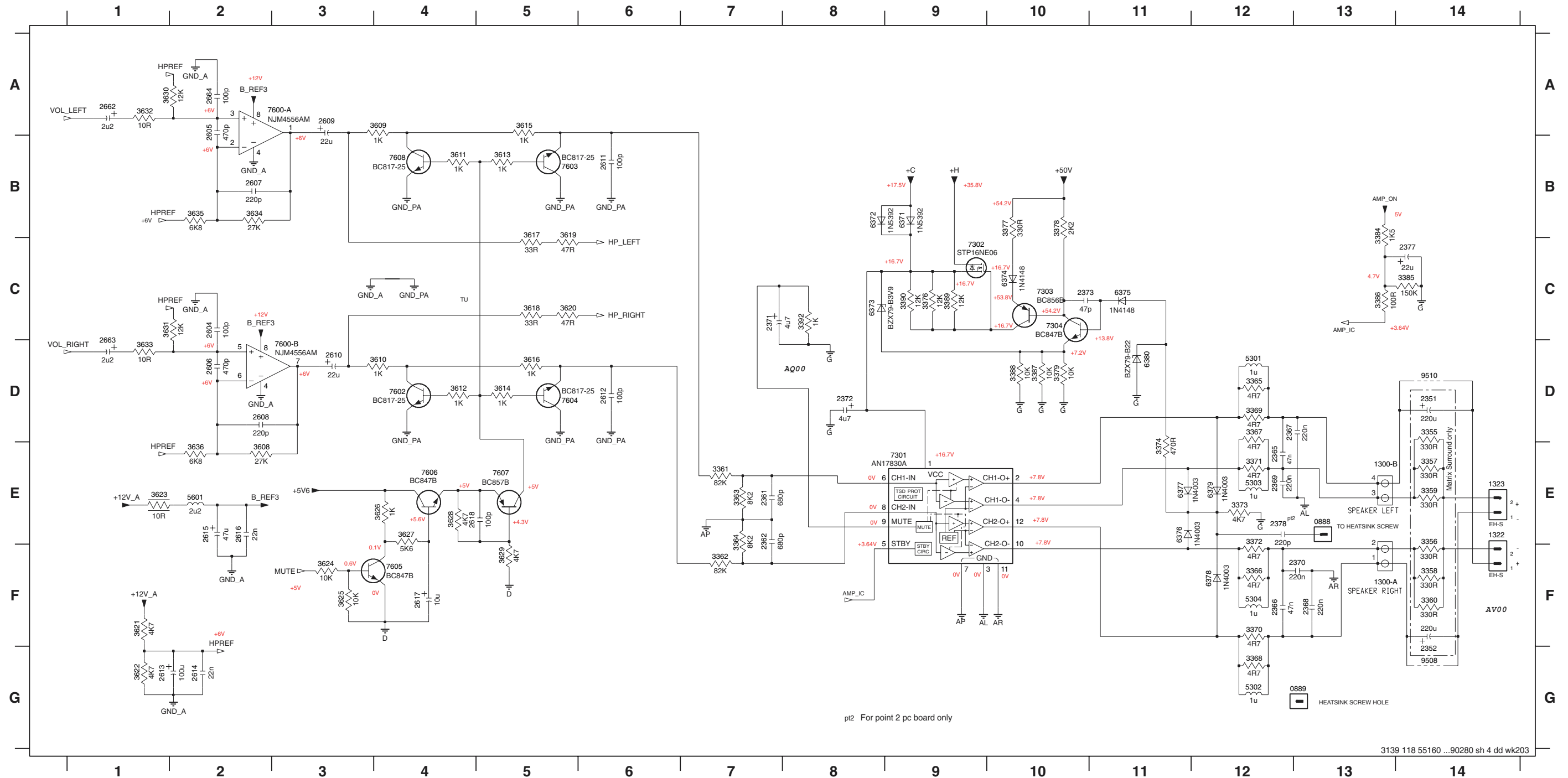

pt2 For point 2 pc board only

3139 118 55160 ...90280 sh 4 dd wk203

NON-CENELEC TUNER CIRCUIT

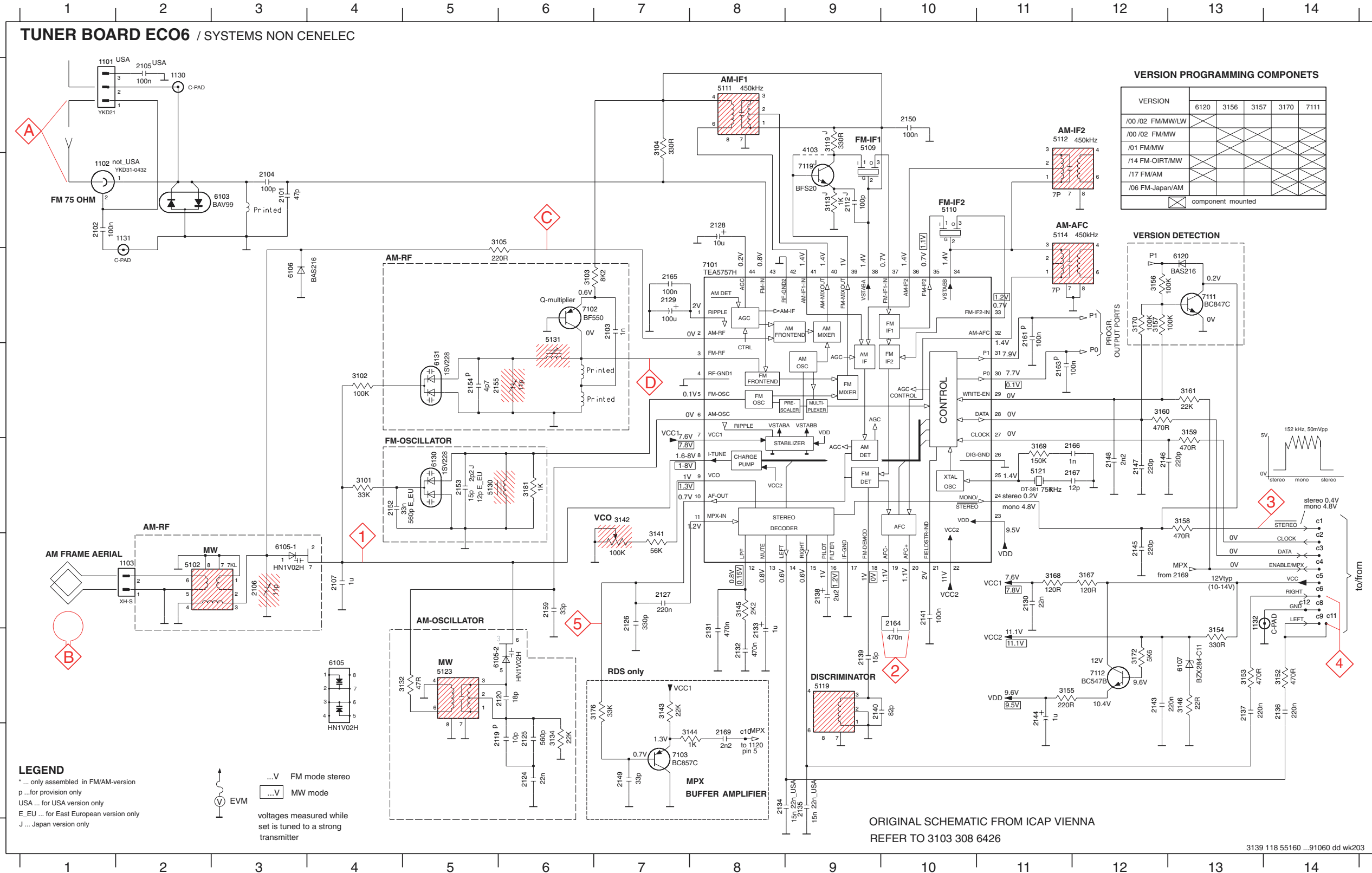

VERSION PROGRAMMING COMPONENTS

VERSION	6120	3156	3157	3170	7111
/00 /02 FM/MW/LW					
/00 /02 FM/MW					
/01 FM/MW					
/14 FM-OIRT/MW					
/17 FM/AM					
/06 FM-Japan/AM					

◻ component mounted

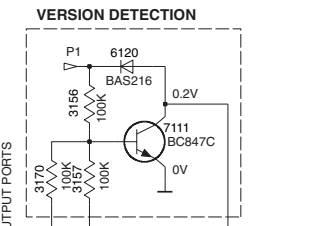

- c1 E14 5119 G9
- c2 F14 5121 E11
- c3 F14 5123 G5
- c4 F14 5130 E5
- c5 F14 5131 C6
- c6 F14 6103 B2
- c8 F14 6105-1 F3
- c9 F14 6105-2 G6
- c10 H8 6106 C3
- c11 F14 6107 G13
- c12 F14 6120 C13
- c13 A1 6130 E5
- c14 B1 6131 D5
- c15 F2 6132 G6
- c16 A2 6133 H7
- c17 B3 7111 C13
- c18 C3 6107 G13
- c19 B1 6120 B1
- c20 C7 6130 C7
- c21 B3 6134 B3
- c22 A2 6105 A2
- c23 F3 6106 F3
- c24 F4 6107 F4
- c25 B9 6112 B9
- c26 H6 6119 H6
- c27 G6 6120 G6
- c28 H6 6124 H6
- c29 H6 6125 H6
- c30 F7 6126 F7
- c31 F7 6127 F7
- c32 B8 6128 B8
- c33 C7 6129 C7
- c34 F11 6130 F11
- c35 B8 6131 B8
- c36 G8 6132 G8
- c37 H8 6133 H8
- c38 H9 6134 H9
- c39 H9 6135 H9
- c40 G14 6136 G14
- c41 G13 6137 G13
- c42 F9 6138 F9
- c43 G9 6139 G9
- c44 G9 6140 G9
- c45 F10 6141 F10
- c46 G12 6143 G12
- c47 G11 6144 G11
- c48 F12 6145 F12
- c49 E12 6146 E12
- c50 E12 6147 E12
- c51 E12 6148 E12
- c52 H7 6149 H7
- c53 A10 6150 A10
- c54 E4 6152 E4
- c55 E5 6153 E5
- c56 D5 6154 D5
- c57 D6 6155 D6
- c58 F6 6159 F6
- c59 C11 6161 C11
- c60 D10 6163 D10
- c61 F10 6164 F10
- c62 C7 6165 C7
- c63 E12 6166 E12
- c64 E12 6167 E12
- c65 H8 6169 H8
- c66 E4 6170 E4
- c67 D4 6172 D4
- c68 C6 6173 C6
- c69 A7 6174 A7
- c70 B6 6175 B6
- c71 B9 6176 B9
- c72 A9 6177 A9
- c73 G5 6178 G5
- c74 H6 6179 H6
- c75 F7 6180 F7
- c76 E7 6181 E7
- c77 G7 6182 G7
- c78 H8 6183 H8
- c79 F8 6184 F8
- c80 G13 6185 G13
- c81 G14 6186 G14
- c82 G13 6187 G13
- c83 G11 6188 G11
- c84 G13 6189 G13
- c85 G11 6190 G11
- c86 C12 6191 C12
- c87 C12 6192 C12
- c88 E13 6193 E13
- c89 D13 6194 D13
- c90 D12 6195 D12
- c91 D13 6196 D13
- c92 F12 6197 F12
- c93 F11 6198 F11
- c94 E11 6199 E11
- c95 C12 6200 C12
- c96 G12 6201 G12
- c97 G7 6202 G7
- c98 E5 6203 E5
- c99 A9 6204 A9
- c100 F2 6205 F2
- c101 B10 6206 B10
- c102 A8 6207 A8
- c103 A11 6208 A11
- c104 B11 6209 B11

LEGEND

- * ... only assembled in FM/AM-version
- p...for provision only
- USA ... for USA version only
- E_EU ... for East European version only
- J ... Japan version only

...V FM mode stereo
 ...V MW mode
 ...V voltages measured while set is tuned to a strong transmitter

ORIGINAL SCHEMATIC FROM ICAP VIENNA
 REFER TO 3103 308 6426

3139 118 55160 ...91060 dd wk203

CENELEC TUNER CIRCUIT

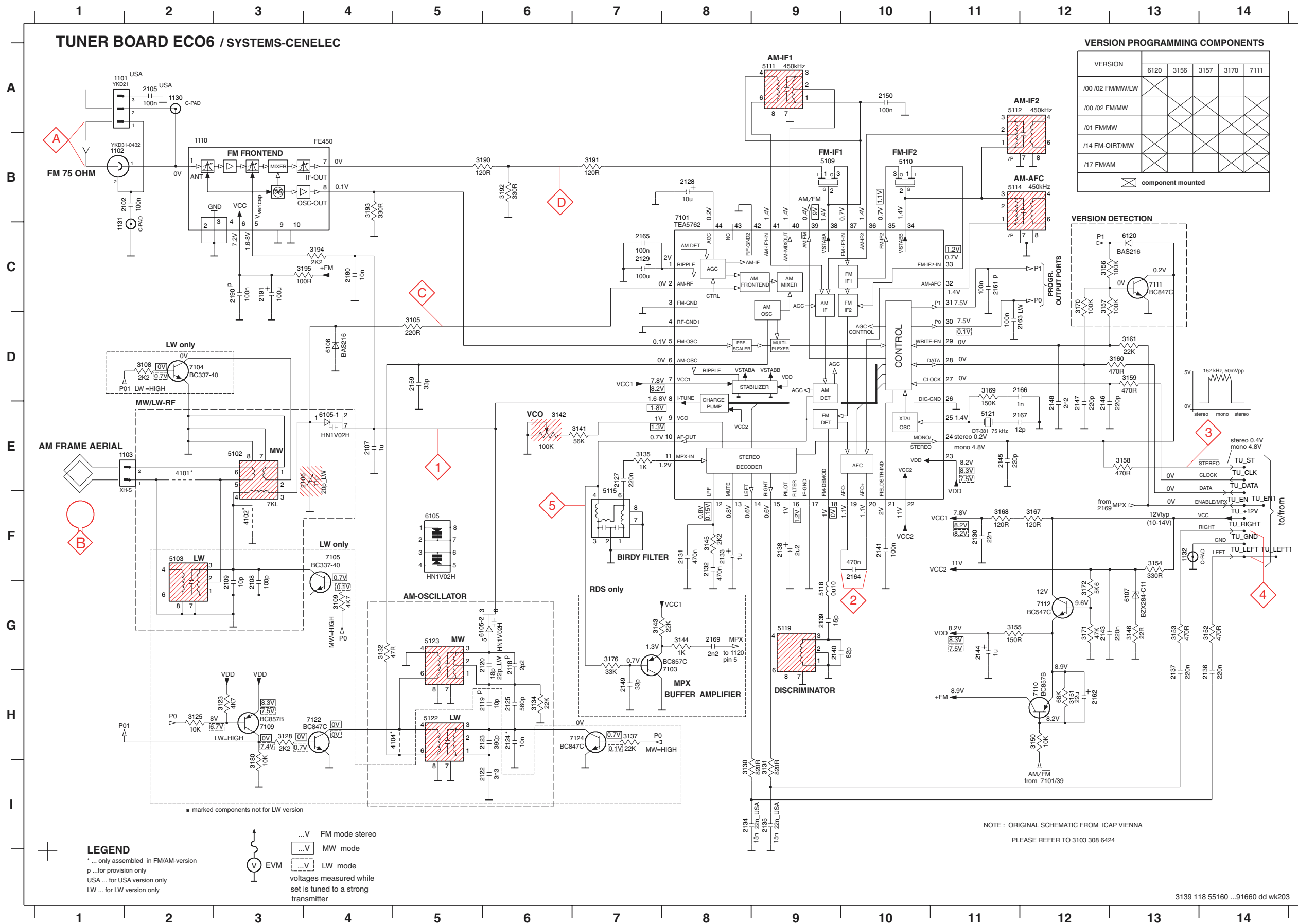

VERSION	6120	3156	3157	3170	7111
/00 /02 FM/MW/LW					
/00 /02 FM/MW					
/01 FM/MW					
/14 FM-OIRT/MW					
/17 FM/AM					

component mounted

- AM G13
- FM G13
- 1101 A2
- 1102 B1
- 1103 E2
- 1110 B2
- 1130 A2
- 1131 C1
- 1132 F13
- 2102 B2
- 2105 A2
- 2106 E3
- 2107 E4
- 2108 G3
- 2109 G3
- 2118 G6
- 2119 H6
- 2120 G6
- 2122 I6
- 2123 H6
- 2124 H6
- 2125 H6
- 2127 E7
- 2128 B8
- 2129 C7
- 2130 F11
- 2131 F8
- 2132 F8
- 2133 F8
- 2134 I8
- 2135 I9
- 2136 H14
- 2137 H13
- 2138 F9
- 2139 G9
- 2140 G9
- 2141 F10
- 2143 G12
- 2144 G11
- 2145 E11
- 2146 E12
- 2147 E12
- 2148 E12
- 2149 H7
- 2150 A10
- 2159 D5
- 2161 C11
- 2162 H12
- 2163 D11
- 2164 F10
- 2165 C7
- 2166 D12
- 2167 E12
- 2169 G8
- 2180 C4
- 2190 C3
- 2191 C3
- 3105 D5
- 3108 D2
- 3109 G4
- 3123 H3
- 3125 H2
- 3128 H3
- 3130 I8
- 3131 I9
- 3132 G4
- 3134 H6
- 3135 E7
- 3137 H7
- 3141 E7
- 3142 E6
- 3143 G7
- 3144 G8
- 3145 F8
- 3146 G13
- 3150 H12
- 3151 H12
- 3152 G14
- 3153 G13
- 3154 F13
- 3155 G11
- 3156 C12
- 3157 C12
- 3158 E13
- 3159 D13
- 3160 D13
- 3161 D13
- 3167 F12
- 3168 F11
- 3169 D11
- 3170 C12
- 3171 G12
- 3172 G12
- 3176 G7
- 3180 I3
- 3190 B6
- 3191 B7
- 3192 B6
- 3193 B4
- 3194 C4
- 3195 C4
- 4101 E2
- 4102 F3
- 4104 H5
- 5102 E3
- 5103 F2
- 5109 B9
- 5110 B10
- 5111 A9
- 5112 A11
- 5114 B11
- 5115 F7