

Service
Service
Service



Service Manual



TABLE OF CONTENTS

Handling Chip Components and Safety1 - 1

Technical Specification & Service tools.....2 - 1

Service Measurement.....2 - 2

Connections and controls.....3 - 1..3 - 2

Disassembly Diagram.....4 - 1

Block Diagram5 - 1

Wiring Diagram.....5 - 2

Control Board

 Circuit diagram6 - 1

 Layout diagram.....6 - 1

Rectifier Board

 Circuit diagram6 - 2

 Layout diagram.....6 - 2

Tuner Board

 Circuit diagram7 - 1

 Layout diagram.....7 - 2

 Tuner adjustment7 - 2

Recorder Board

 Circuit diagram8 - 1

 Layout diagram.....8 - 2

 Tape deck adjustment.....8 - 2

Power Board

 Circuit diagram9 - 1

 Layout diagram.....9 - 2

CD Board

 Circuit diagram10 - 1

 Layout diagram.....10 - 2

Exploded view - cabinet.....11 - 1

Mechanical partslist11 - 2

Electrical partslist12 - 1 .. 12 - 5

© Copyright 2001 Philips Consumer Electronics B.V. Eindhoven, The Netherlands
All rights reserved. No part of this publication may be reproduced, stored in a retrieval system or transmitted, in any form or by any means, electronic, mechanical, photocopying, or otherwise without the prior permission of Philips.

Published by YT 0228 Service Audio Printed in The Netherlands Subject to modification

GB 3140 785 22950



PHILIPS

HANDLING CHIP COMPONENTS

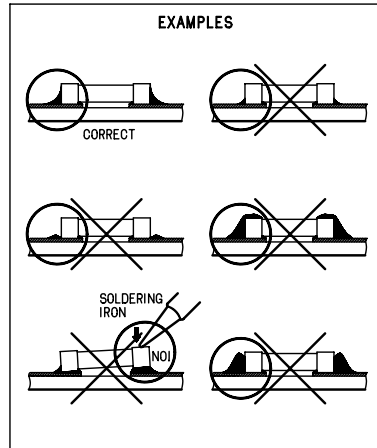
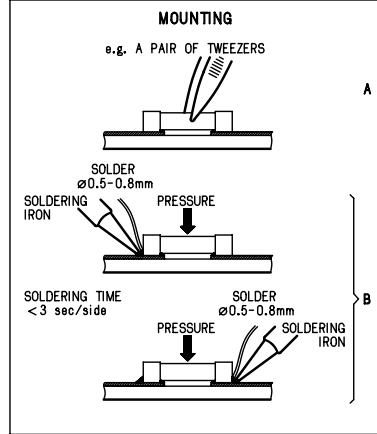
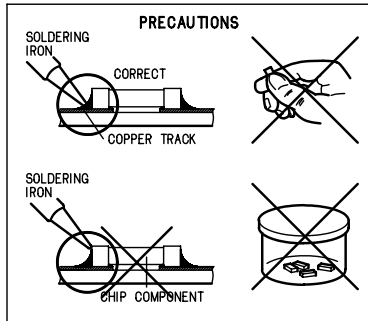
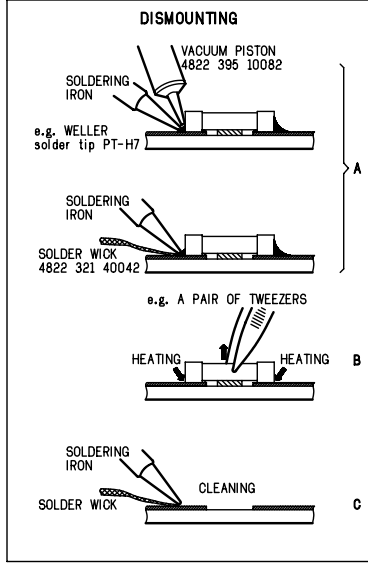
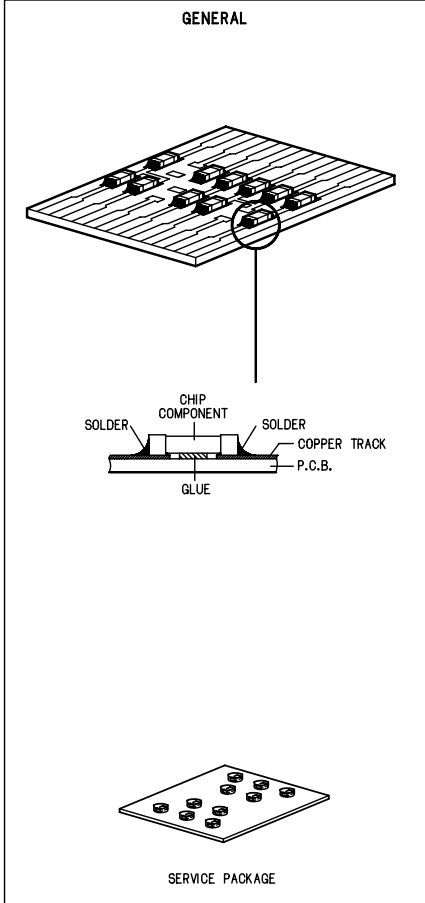

GB WARNING
All ICs and many other semiconductors are susceptible to electrostatic discharges (ESD). Careless handling during repair can reduce life drastically. When repairing, make sure that you are connected with the same potential as the mass of the set via a wristband with resistance. Keep components and tools at this potential.



NL WAARSCHUWING
Alle IC's en vele andere halfgeleiders zijn gevoelig voor electrostatische ontladingen (ESD). Onzorgvuldig behandelen tijdens reparatie kan de levensduur drastisch doen verminderen. Zorg ervoor dat u tijdens reparatie via een polsband met weerstand verbonden bent met hetzelfde potentiaal als de massa van het apparaat. Houd componenten en hulpmiddelen ook op ditzelfde potentiaal.

F ATTENTION
Tous les IC et beaucoup d'autres semi-conducteurs sont sensibles aux décharges statiques (ESD). Leur longévité pourrait être considérablement écourtée par le fait qu'aucune précaution n'est prise à leur manipulation. Lors de réparations, s'assurer de bien être relié au même potentiel que la masse de l'appareil et enfilez le bracelet sertit d'une résistance de sécurité. Veiller à ce que les composants ainsi que les outils que l'on utilise soient également à ce potentiel.

D WARNUNG
Alle ICs und viele andere Halbleiter sind empfindlich gegenüber elektrostatischen Entladungen (ESD). Unsorgfältige Behandlung im Reparaturfall kann die Lebensdauer drastisch reduzieren. Sorgen Sie dafür, daß Sie im Reparaturfall über ein Pulsarmband mit Widerstand mit dem Massepotential des Gerätes verbunden sind. Halten Sie Bauteile und Hilfsmittel ebenfalls auf diesem Potential.

I AVVERTIMENTO
Tutti IC e parecchi semi-conduttori sono sensibili alle scariche statiche (ESD). La loro longevità potrebbe essere fortemente ridotta in caso di non osservazione della più grande cauzione alla loro manipolazione. Durante le riparazioni occorre quindi essere collegato allo stesso potenziale che quello della massa dell'apparecchio tramite un braccialetto a resistenza. Assicurarsi che i componenti e anche gli utensili con quali si lavora siano anche a questo potenziale.

GB
Safety regulations require that the set be restored to its original condition and that parts which are identical with those specified be used. Safety components are marked by the symbol



NL
Veiligheidsbepalingen vereisen, dat het apparaat in zijn oorspronkelijke toestand wordt teruggebracht en dat onderdelen, identiek aan de gespecificeerde, worden toegepast. De Veiligheidsonderdelen zijn aangeduid met het symbool

F
Les normes de sécurité exigent que l'appareil soit remis à l'état d'origine et que soient utilisées les pièces de rechange identiques à celles spécifiées. Les composants de sécurité sont marqués

D
Bei jeder Reparatur sind die geltenden Sicherheitsvorschriften zu beachten. Der Originalzustand des Gerätes darf nicht verändert werden. Für Reparaturen sind Originalersatzteile zu verwenden. Sicherheitsbauteile sind durch das Symbol markiert.

I
Le norme di sicurezza estigono che l'apparecchio venga rimesso nelle condizioni originali e che siano utilizzati i pezzi di ricambio identici a quelli specificati. Componenti di sicurezza sono marcati con

GB DANGER: Invisible laser radiation when open. AVOID DIRECT EXPOSURE TO BEAM.



GB
After servicing and before returning the set to customer perform a leakage current measurement test from all exposed metal parts to earth ground, to assure no shock hazard exists. The leakage current must not exceed 0.5mA.

S Varning!
Osynlig laserstrålning när apparaten är öppnad och spårren är urkopplad. Betrakta ej strålen.

DK Advarsel!
Usynlig laserstrålning ved åbning når sikkerhedsafbrydere er ude af funktion. Undgå udsættelse for stråling.

FIN Varoitus!
Avatussa laitteessa ja suojauslaituksen ohitettaessa olet alttiina näkymättömälle laserisäteilylle. Älä katso säteeseen!

F
"Pour votre sécurité, ces documents doivent être utilisés par des spécialistes agréés, seuls habilités à réparer votre appareil en panne".

TECHNICAL SPECIFICATIONS

GENERAL

Mains voltage	-/00C : 230 V
	-/01 : 120 / 230 V
	-/05/10 : 240V
	-/17 : 120 V
Mains frequency	-/00C/05/10 : 50 Hz
	-/01 : 50 / 60 Hz
	-/17 : 60 Hz
Battery	: 9 V (R14/UM-2/C-size x 6)
Power consumption	: 12 W
Dimension (W x H x D)	: 360 x 225 x 152mm
Weight	: 2.3 Kg

AMPLIFIER

Output power	mains : 2 x 1 W
	battery : 2 x 1 W
Speaker impedance	: 2 x 8 ohm
Frequency response	: 100 Hz - 10 kHz (± 3 dB)

TUNER - FM SECTION

Tuning range	: 87.5 - 108 MHz
IF frequency	: 10.7 MHz \pm 0.2 MHz
Sensitivity	: 28 dBf at 26dB S/N
Selectivity	: 24 dB at 300kHz
IF rejection	: 65 dB
Image rejection	: 26 dB

TUNER - AM SECTION

Tuning range	: 512 - 1635 kHz
	-/17 : 520 - 1700 kHz
IF frequency	: 468 kHz \pm 3 kHz
Sensitivity	: 4000 μ V/m at 26dB S/N
Selectivity	: 20 dB
IF rejection	: 70 dB
Image rejection	: 32 dB

AUDIO CASSETTE RECORDER

Number of tracks	: 1 stereo
Tape speed	: 4.76 cm/sec \pm 3%
Wow & flutter	: < 0.48 JIS UWTD
Fast wind/rewind C60	: 130 sec.
Frequency response	P/B : 125 - 8000 Hz
S/N ratio	: \geq 36 dB

COMPACT DISC

Frequency response	: 100 Hz - 10 kHz
S/N ratio	: 60 dB
Channel difference	1 kHz : 2 dB
Channel crosstalk	1 kHz : 40 dB
Laser wavelength	: 780 \pm 20 nm
Laser light power	: < 0.5 mW

SERVICE TOOLS

Audio signal disc SBC 429.....	4822 397 30184
Playability test disc SBC 444.....	4822 397 30245
Test disc 5 (disc without errors) +	
Test disc 5A (disc with dropout errors, black spots and fingerprints)	
SBC 426/426A.....	4822 397 30096
Burn in test disc (65 min. 1kHz signal at -30 dB level without "pause").....	4822 397 30155

AVAILABLE ESD PROTECTION EQUIPMENT

anti-static table mat	large 1200x650x1.25mm	4822 466 10953
	small 600x650x1.25m	4822 466 10958
anti-static wristband		4822 395 10223
connection box (3 press stud connections, 1M Ω)		4822 320 11307
extendible cable (2m, 2M Ω , to connect wristband to connection box)		4822 320 11305
connecting cable (3m, 2M Ω , to connect table mat to connection box)		4822 320 11306
earth cable (1M Ω , to connect any product to mat or to connection box)		4822 320 11308
KIT ESD3 (combining all 6 prior products - small table mat)		4822 310 10671
wristband tester		4822 344 13999

SERVICE MEASUREMENT

Tuner SW

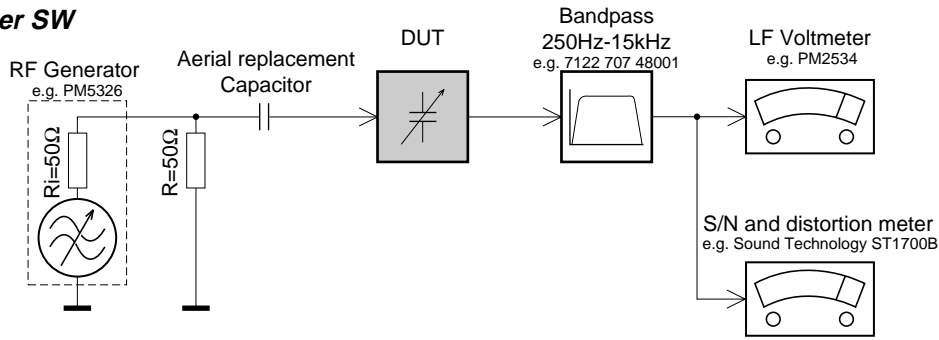

To avoid atmospheric interference all AM-measurements have to be carried out in a Faraday«s cage. Use a bandpass filter (or at least a high pass filter with 250Hz) to eliminate hum (50Hz, 100Hz).

Tuner AM (MW,LW)

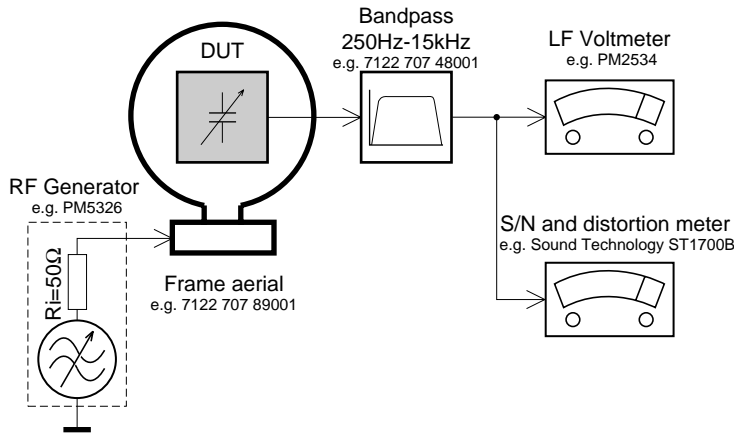

To avoid atmospheric interference all AM-measurements have to be carried out in a Faraday«s cage.

CD

Use Audio Signal Disc SBC429 4822 397 30184 (replaces test disc 3)
L.P.F. = 13th order filter 4822 395 30204

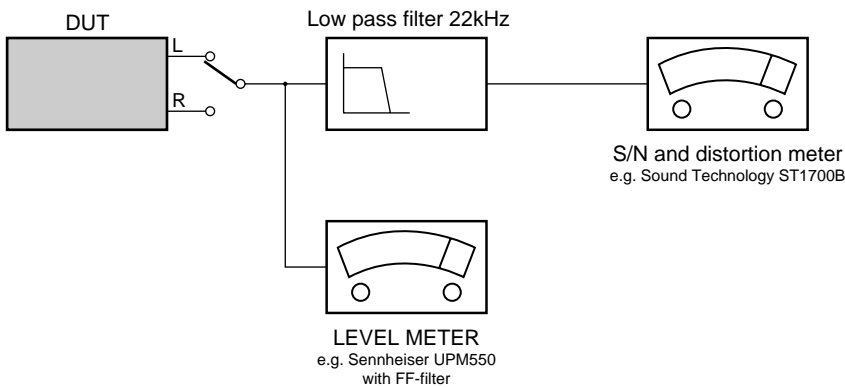

CONNECTIONS AND CONTROLS

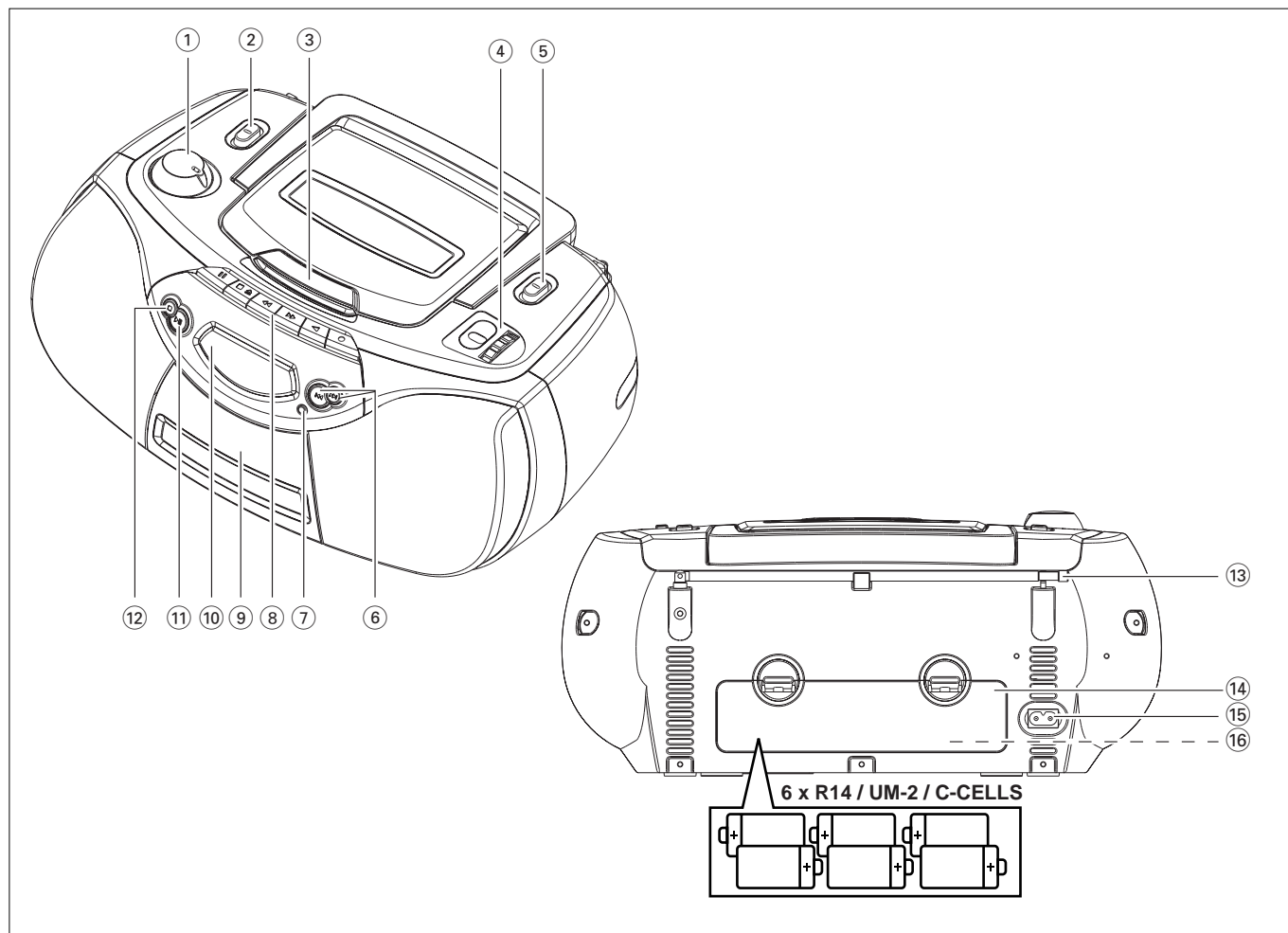

Top and front panels (See 1)

- ① **VOLUME** – to adjust volume level
- ② **Source selector : CD, TUNER, TAPE/POWER OFF**
– selects CD, tuner or tape source of sound
– power off switch
- ③ **CD door**
- ④ **TUNING** – tunes to radio stations
- ⑤ **BAND** – selects waveband
- ⑥ **PREVIOUS, NEXT ◀◀, ▶▶**
– skips or searches a passage/track backwards or forward
- ⑦ **PROG** – programs and reviews programmed track numbers
- ⑧ **CASSETTE RECORDER keys:**
 - ⏸ – pauses playback or recording
 - ▲ – stops the tape;
– opens the cassette holder
 - ◀◀ or ▶▶ – fast rewinds/ winds tape
 - ▶ – starts playback
 - – starts recording
- ⑨ **Cassette door**
- ⑩ **CD Display** – shows the CD functions
- ⑪ **PLAY/PAUSE ▶⏸** - starts or pauses CD playback.
- ⑫ **STOP ■** – stop playback;
– erases a CD program.

Back panel

- ⑬ **Telescopic antenna** - improves FM reception.
Note: AM band antenna is built into set (see Tuner reception)
- ⑭ **Battery door** - open to insert 6 x 1.5V **R-14/ UM2/ C-cells**.
- ⑮ **AC POWER/MAINS** - inlet for power cord.
- ⑯ **Voltage selector** – (inside the battery compartment, not all versions) adjust to match the local voltage 110/220V before plugging in the set.

CONNECTIONS AND CONTROLS

Power Supply

Whenever convenient, use the mains supply cord if you want to conserve battery life. Make sure you remove the plug from the set and wall outlet before inserting batteries.

Batteries (not included)

Open the battery compartment and insert six batteries, type **R-14, UM-2** or **C-cells**, (preferably alkaline) with the correct polarity as indicated by the "+" and "-" symbols inside the compartment. (See **1**)

Replace the compartment door, making sure the batteries are firmly and correctly in place. The set is now ready to operate.

Batteries contain chemical substances, so they should be disposed of properly.

Incorrect use of batteries can cause electrolyte leakage and will corrode the compartment or cause the batteries to burst:

Do not mix battery types: e.g. alkaline with carbon zinc. Only use batteries of the same type for the set.

When inserting new batteries, do not try to mix old batteries with the new ones.

Remove the batteries if the set is not to be used for a long time.

Using AC Mains

Check if the power/mains voltage, **as shown on the type plate located on the bottom of the set**, corresponds to your local power supply. If it does not, consult your dealer or service center.

Connect the power cord to the AC POWER/MAINS inlet and the wall socket. The mains lead is now connected and ready for use.

To switch the set off completely, withdraw the power cord from the wall socket.

Disconnect the mains lead from the wall socket to protect your set during heavy thunderstorms.

The type plate is located on the bottom of the set.

Switching POWER on/off:

Save energy

To avoid unnecessary energy consumption, always adjust the **source selector** to **TAPE/POWER OFF** after using the set. Also check that the tape deck keys are released.

General operation

- 1 To select your sound source adjust the **source selector** to : **CD, TUNER** or **TAPE/POWER OFF**.
- 2 Adjust the sound with the **VOLUME** control.
- 3 To switch off the set, adjust the source selector to **TAPE/POWER OFF** position and check the cassette keys are released.

Trouble shooting

Problem

- Possible cause
- Remedy

No sound /power

- Volume not adjusted
- Adjust the VOLUME
- Power cord not securely connected
- Connect the AC power cord properly
- Batteries dead/ incorrectly inserted
- Insert (fresh) batteries correctly

Display does not function properly/ No reaction to operation of any of the controls

- Electrostatic discharge
- Switch off and unplug the set. Reconnect after a few seconds

The CD skips tracks

- CD damaged or dirty
- Replace or clean CD
- Program is active
- Quit program mode

- - indication

- No CD inserted
- Insert a CD
- CD badly scratched or dirty
- Replace/ clean CD, see Maintenance
- Laser lens steamed up
- Wait until lens has cleared
- CD-R is blank or not finalized/ CD-RW inserted
- Use a finalized CD-R or suitable CD Audio disc only

Poor cassette sound quality

- Dust and dirt on the heads, etc.
- Clean deck parts, see Maintenance
- Use of incompatible cassette types (METAL or CHROME)
- Only use NORMAL (IEC I) for recording

Recording does not work

- Cassette tab(s) may be broken
- Apply adhesive tape over the missing tab space

For more information on operation instruction please visit Philips Audio internet site :
<http://www.audio.philips.com>

DISASSEMBLY DIAGRAM

- A. REMOVE BACK CABINET ASSEMBLY**
- REMOVE SCREWS A1(3x10) 3PCS
 - REMOVE SCREWS A2(3x30) 5PCS
 - REMOVE BACK CABINET

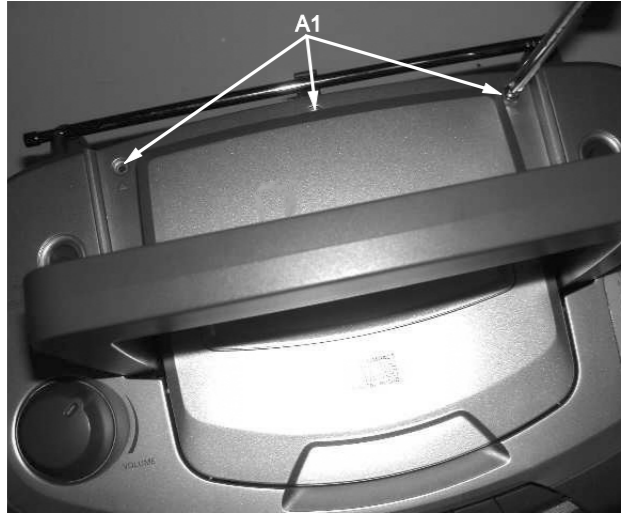

- D REMOVE DECK MECHANISM**
- REMOVE SCREWS D5(3x10) 4PCS
 - REMOVE SCREWS D6(2.5x10) 4PCS

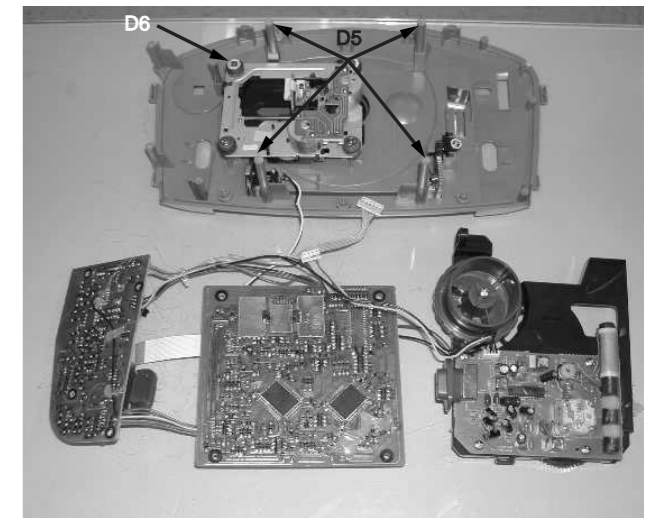

- B. REMOVE HANDLE**
- PRESS DOWN THE STOPPER AND PULL THE HANDLE OUT
 - REMOVE HANDLE



- C REMOVE TOP CABINET ASSEMBLY**
- REMOVE SCREWS C3(3x20) 2PCS
 - REMOVE SCREWS C4(3x10) 1PC
 - REMOVE TOP CABINET



BLOCK DIAGRAM

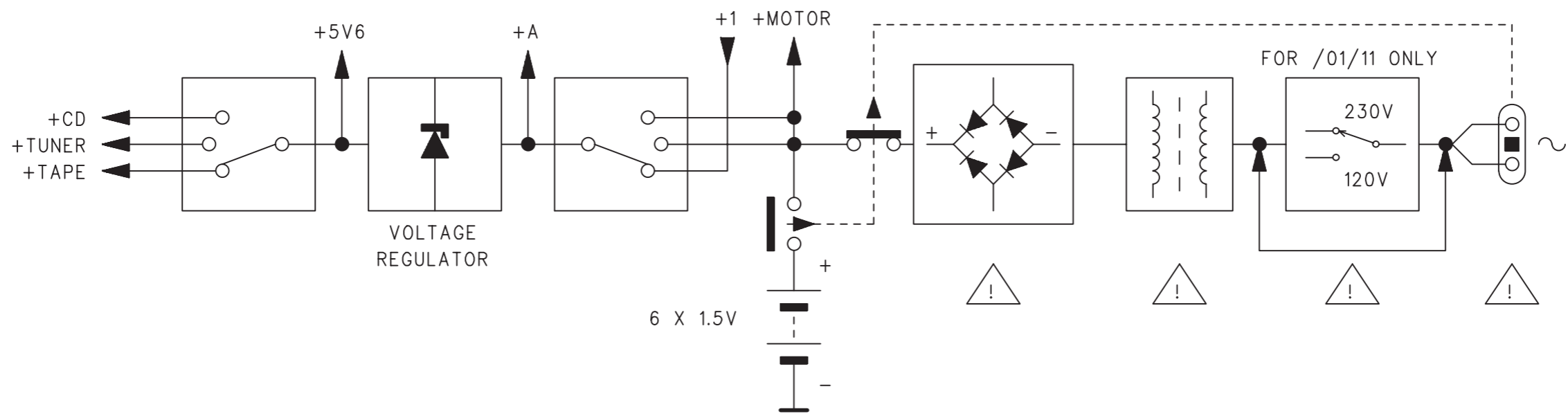
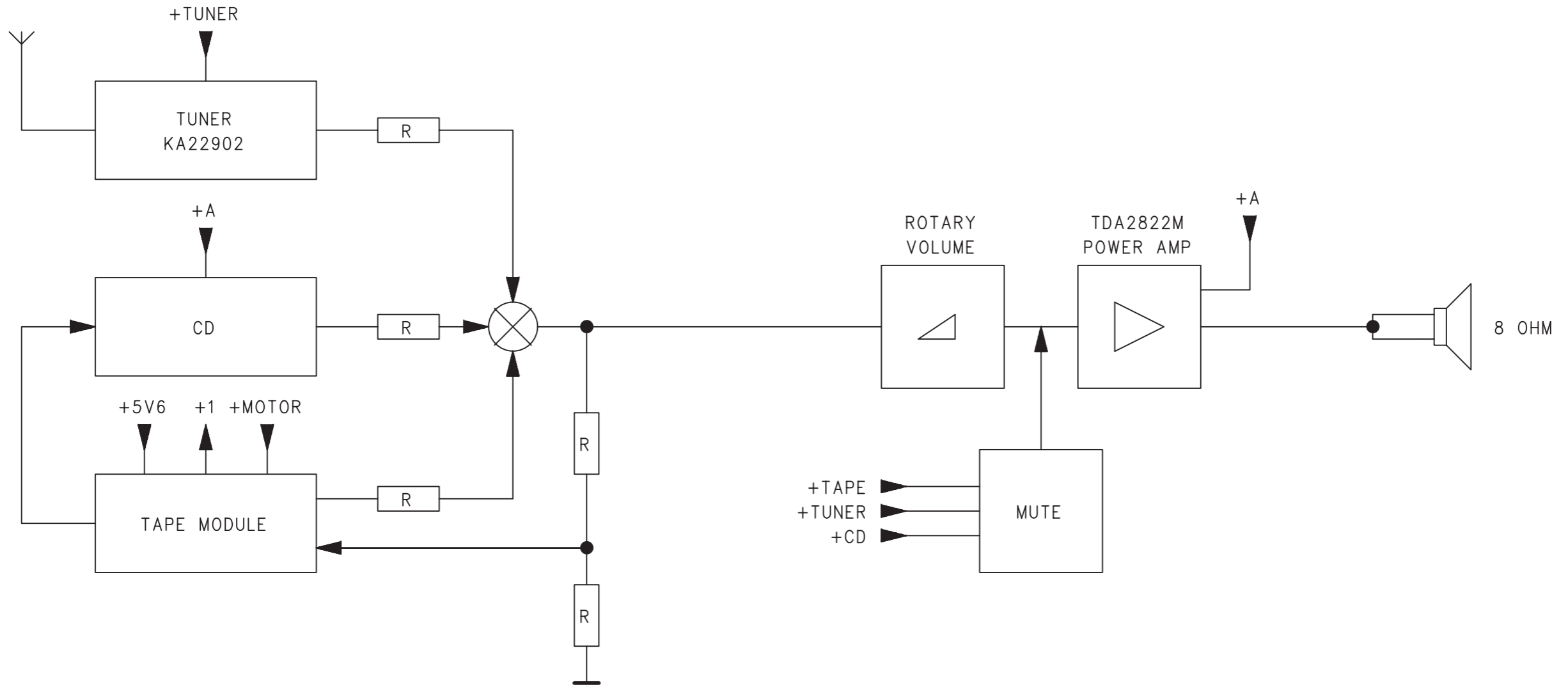

WIRING DIAGRAM

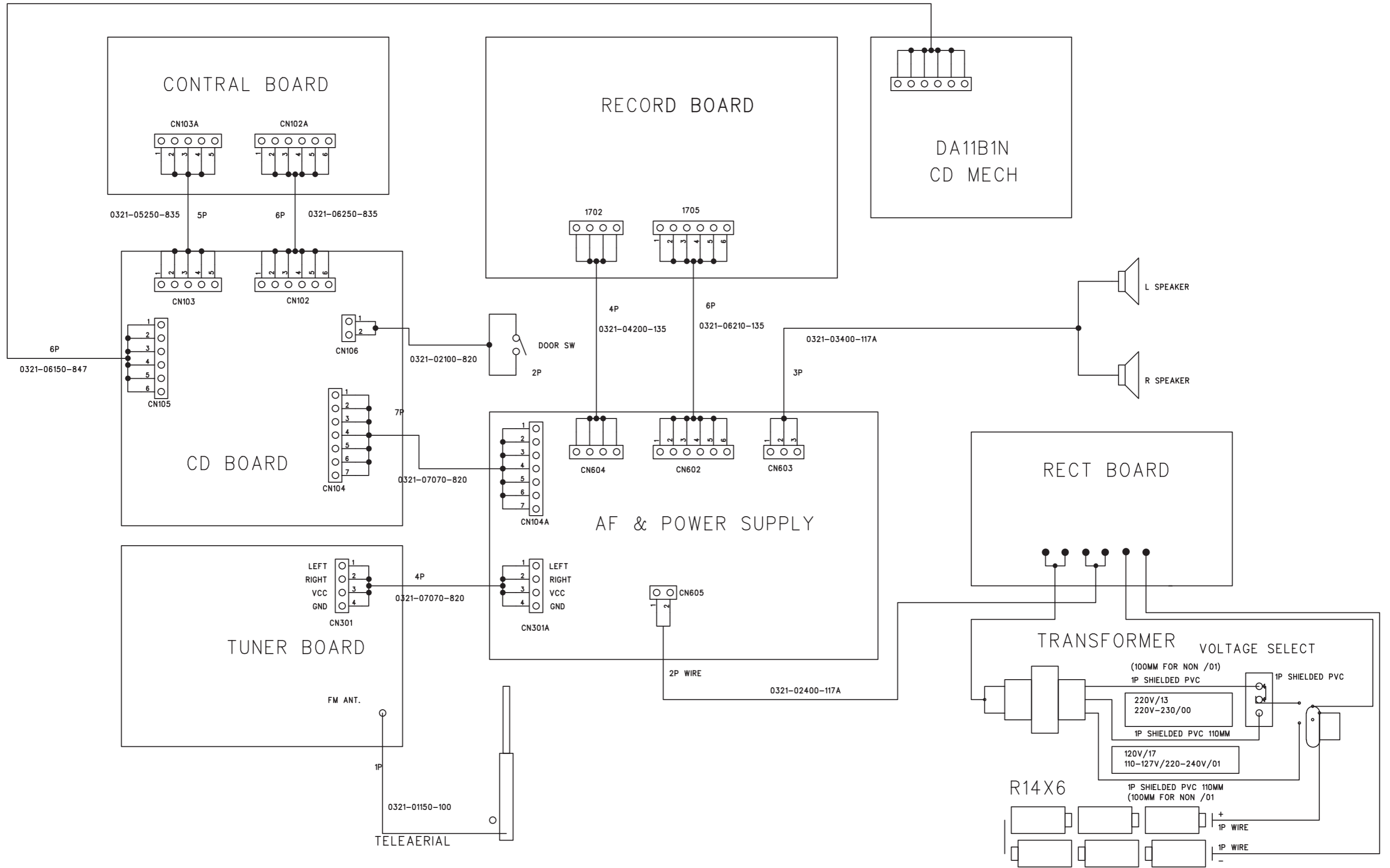

CONTROL BOARD - CIRCUIT / LAYOUT DIAGRAM

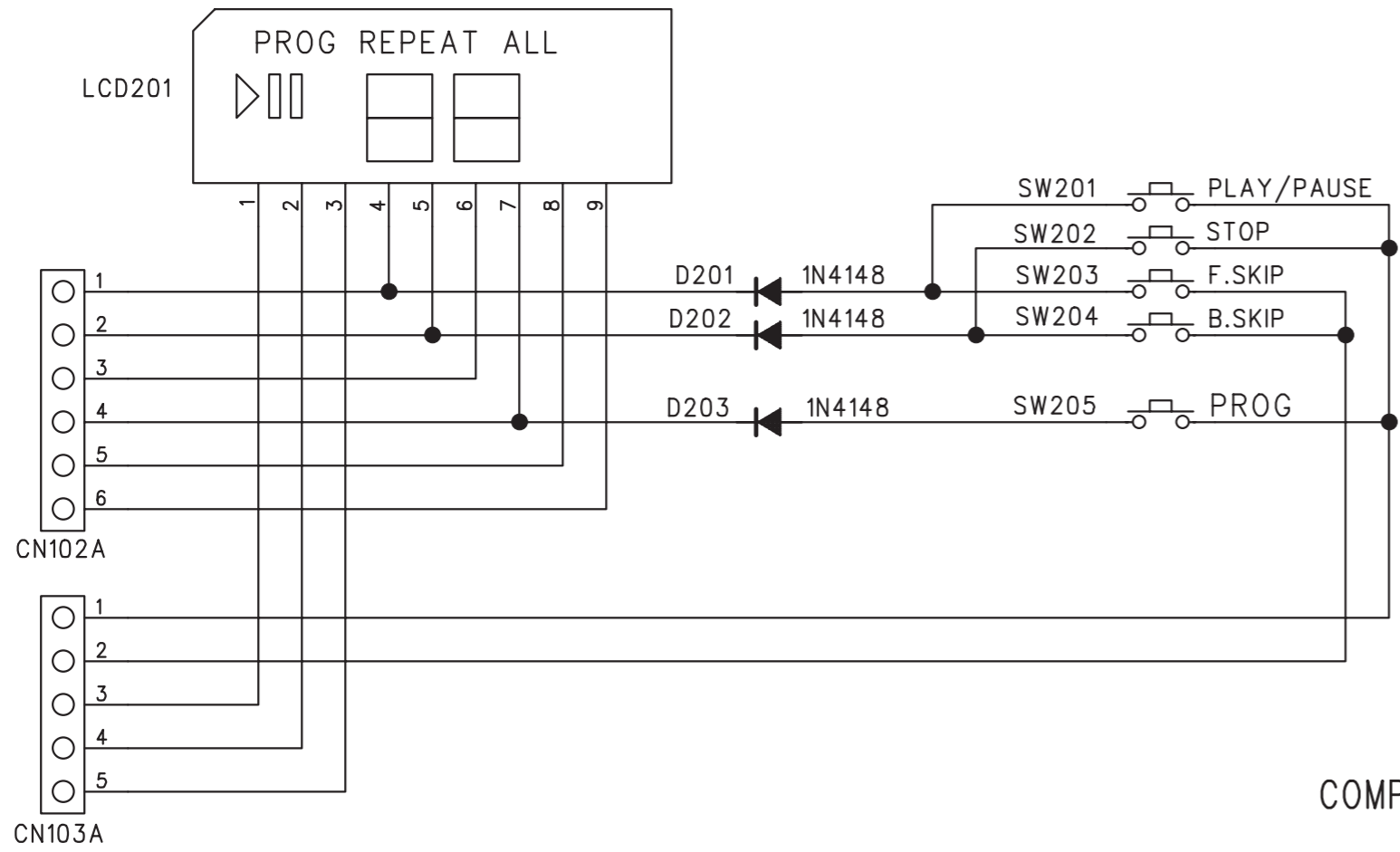

COMPONENT SIDE

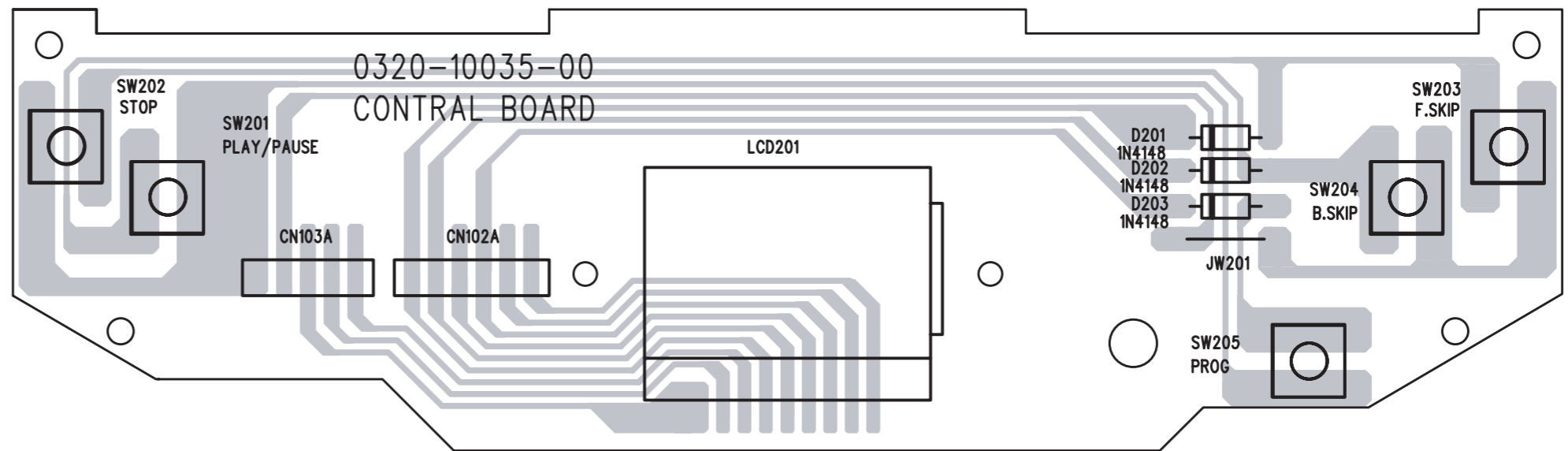

RECTIFIER BOARD - CIRCUIT / LAYOUT DIAGRAM

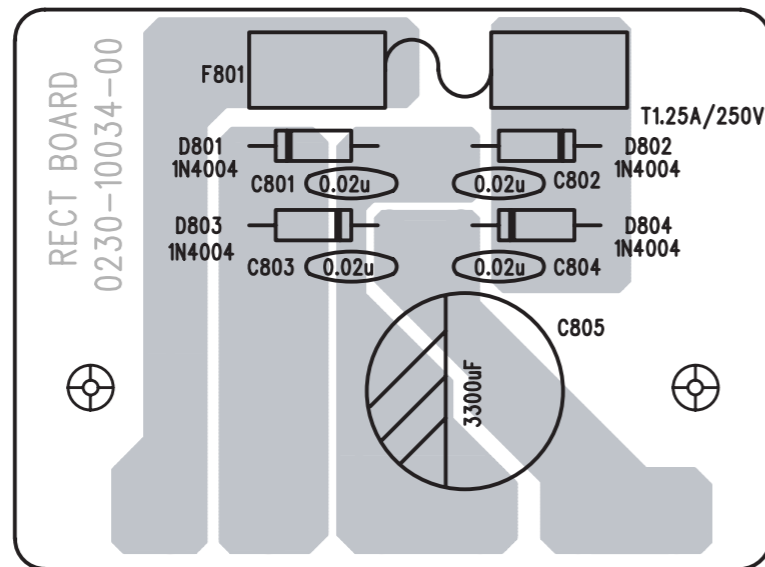
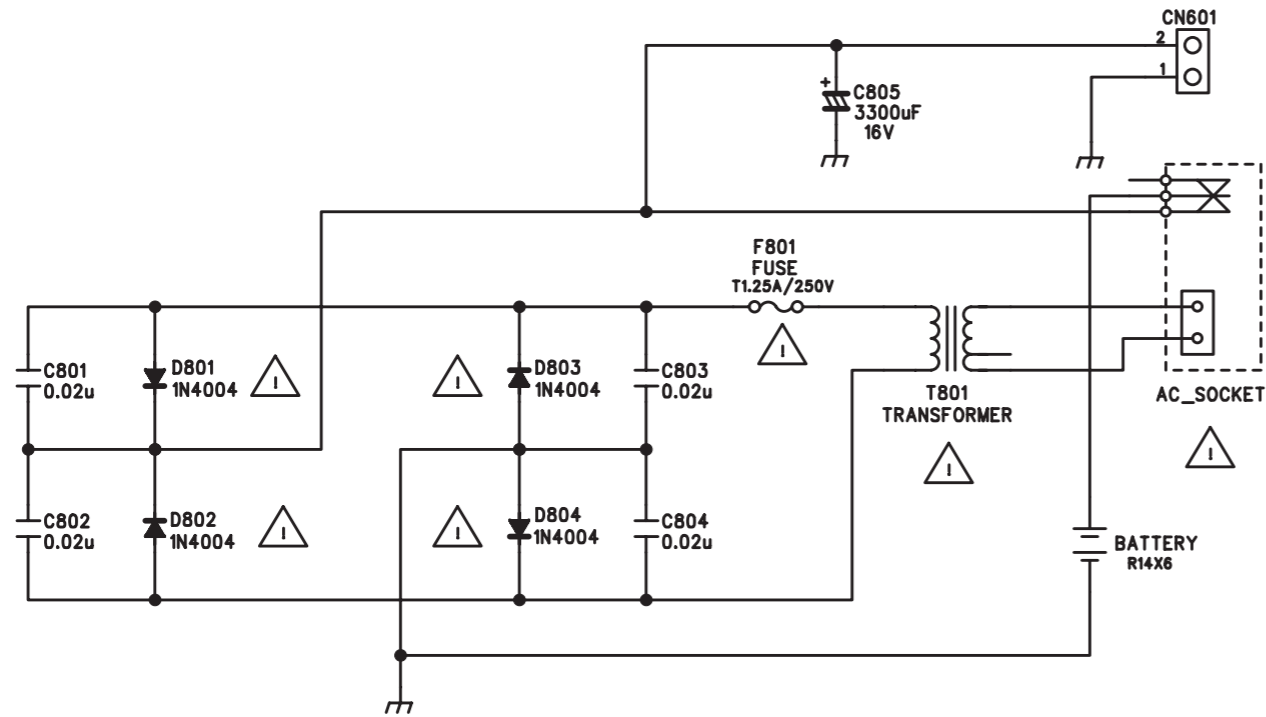

TUNER BOARD - CIRCUIT DIAGRAM

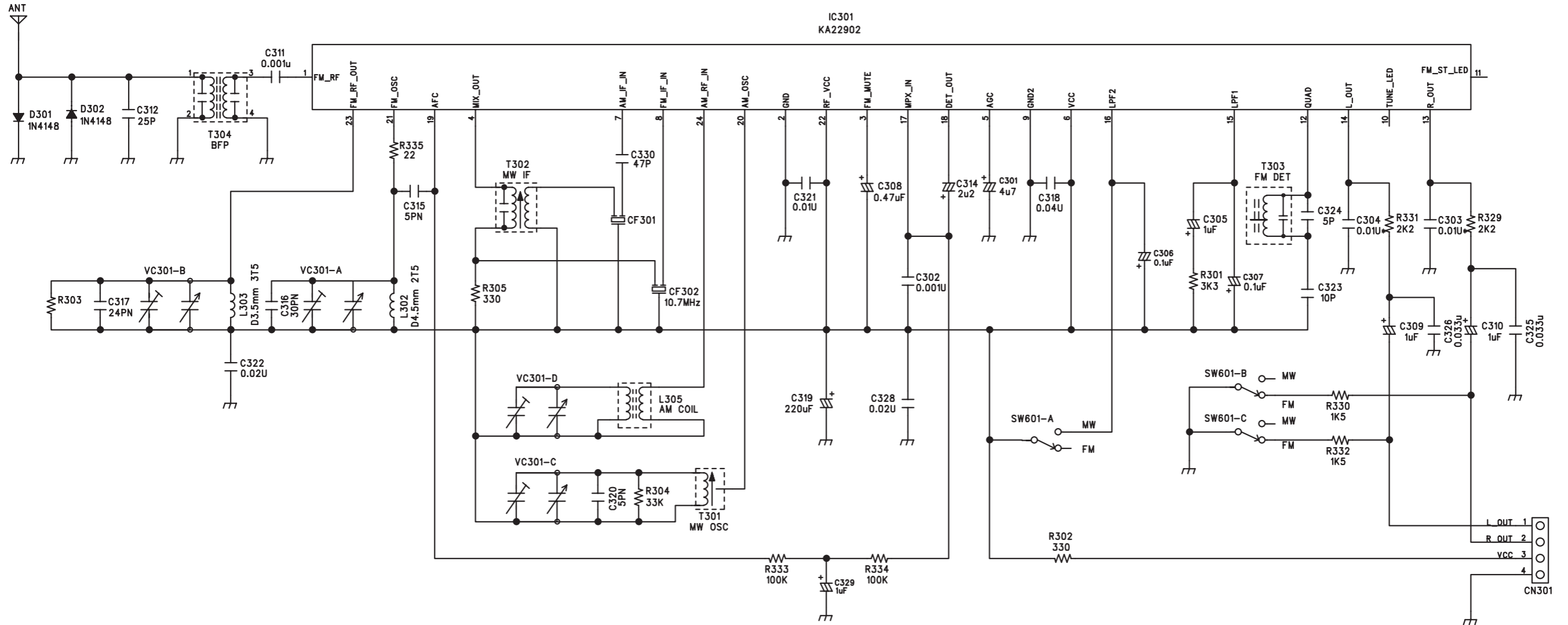

TUNER BOARD LAYOUT DIAGRAM

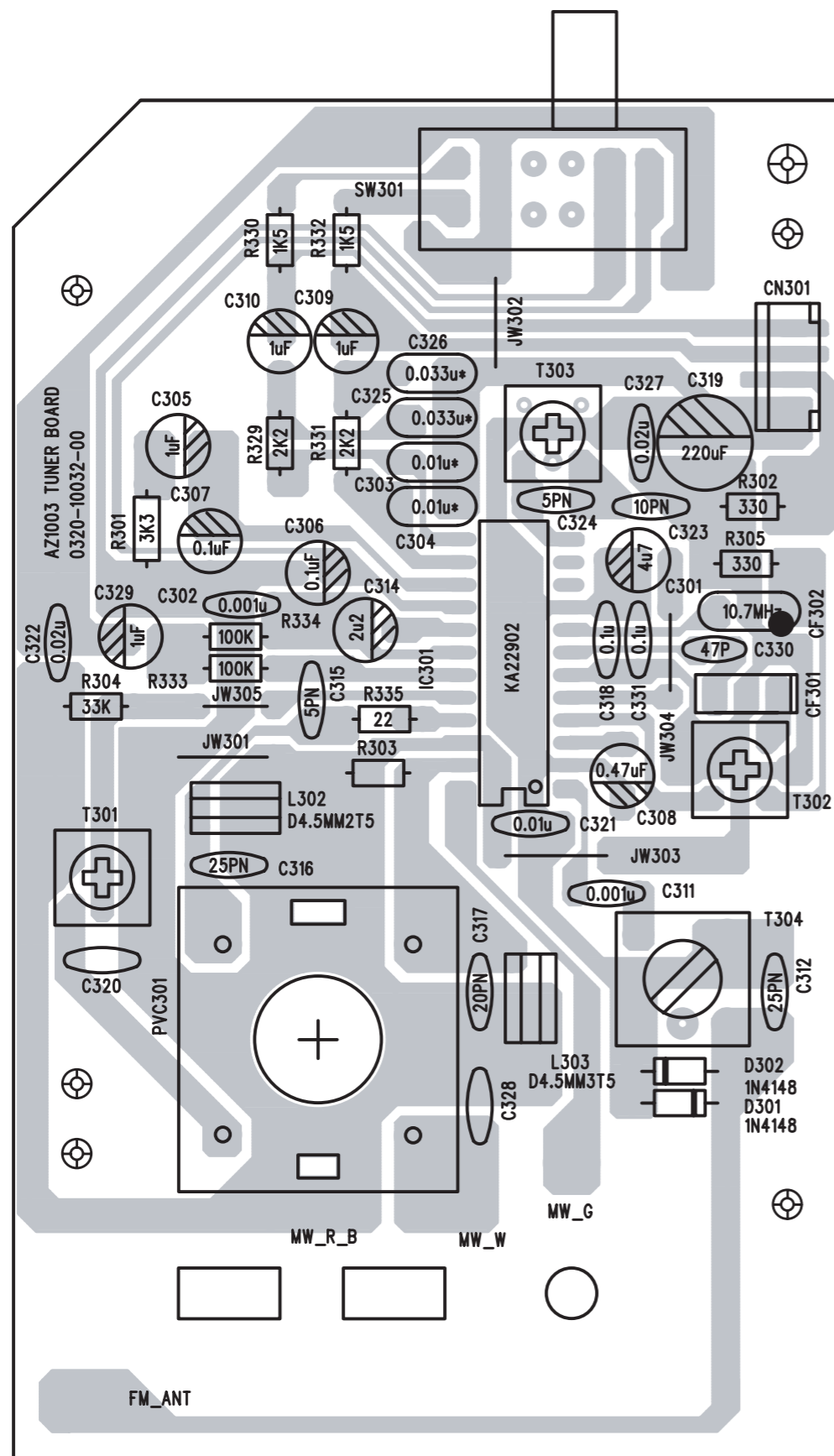

TUNER ADJUSTMENT

Alignment Procedure

Model No. AZ-1003

Instruments Required :

1. AM Signal Generator
2. FM Signal Generator
3. AM/FM if Sweep Generator
4. Dual Trace Oscilloscope
5. Solid State Voltage Meter (SSVM)
6. Frequency Counter
7. Nonmetallic Alignment Tools
8. Test Tape : Teac - MTT 113N (6.3 kHz) or Equiv.
9. Test Tape : Teac - MTT 111N (3 kHz) or Equiv.

Important

1. Check Power Source Voltage
2. Set the Function Switch to Band Being Aligned.
3. Volume Should Be Turned To Minimum.
4. Signal Input Should be Kept as Low as Possible.
5. AM Modulation : 1 kHz 30%
6. FM Modulation : 1 kHz 22.5 kHz DEV.

Radio Alignment

	Frequency	Input	Varian	Adjust	Output	Scope/Meter
MW IF						
	455 kHz	LOOP ANT AM Coil	MIN.	T302	IC301 Pins 18	MAX.
MW IF						
	520 kHz 1750 kHz	LOOP ANT	MAX. MIN.	T301 VC301C	IC301 Pins 18	MAX.
	600 kHz 1400 kHz	AM Coil	600 kHz 1400 kHz	L305 VC301D		MAX.
FM IF						
	10.7 MHz	IC301 Pins 4	MIN.	T303	IC301 Pins 18	Symmetrical
FM IF						
	87.5 MHz 108.5 MHz	FM ANT. C312 Cer. Cap.	MAX. MIN.	L302 VC301A	IC301 Pins 18	MAX.
	90 MHz 106 MHz		90 MHz 106 MHz	L303 VC301B		MAX.

RECORDER BOARD - CIRCUIT DIAGRAM

71	D15	1707	C 3	1709	A14	2706	B 4	2711	F 6	2719	C 8	2727	F 7	2733	H13	2750	D 6	3703	D 3	3712	E 7	3720	F 7	3730	F12	3743	C 9	3761	G 6	7705	G 4	8702	E 1	9753	C13	T705	B14	T710	G11	T718	E 2	T724	E 2
73	E15	1707	G 7	1710	B15	2707	B6	2712	E 7	2721	G 3	2728	C13	2734	G10	2751	H 6	3704	C 4	3713	G 3	3722	A 2	3731	G12	3744	G 9	3762	D 6	7705	C 4	8704	E15	9754	F11	T706	B14	T711	F14	T719	H13	T725	C 7
74	G 9	1707	C 7	1725	A15	2708	C 3	2714	C 3	2722	G 7	2729	C13	2735	G10	2760	H14	3706	D 4	3714	F 3	3723	A 2	3732	H13	3747	G12	5701	F11	8702	F 1	8704	E15	9758	D12	T707	B10	T712	F 5	T721	A14		
1702	G15	1707	E 9	2703	G 7	2709	G 3	2715	C 6	2723	G 5	2730	G11	2738	B 3	2799	H15	3707	D 5	3716	H 4	3726	B 9	3733	F 6	3748	B 3	6704	F 1	8705	F15	T701	A14	T708	B10	T716	F10	T722	G 7				
1707	F 3	1707	E12	2704	C 7	2710	G12	2716	D 5	2726	G 8	2732	G12	2739	B 1	3701	B 6	3710	D 8	3719	H 8	3727	E 9	3734	D11	3749	B 2	7702	H13	8702	E 1	8705	F15	T702	A14	T709	D14	T717	F 2	T723	F 2		

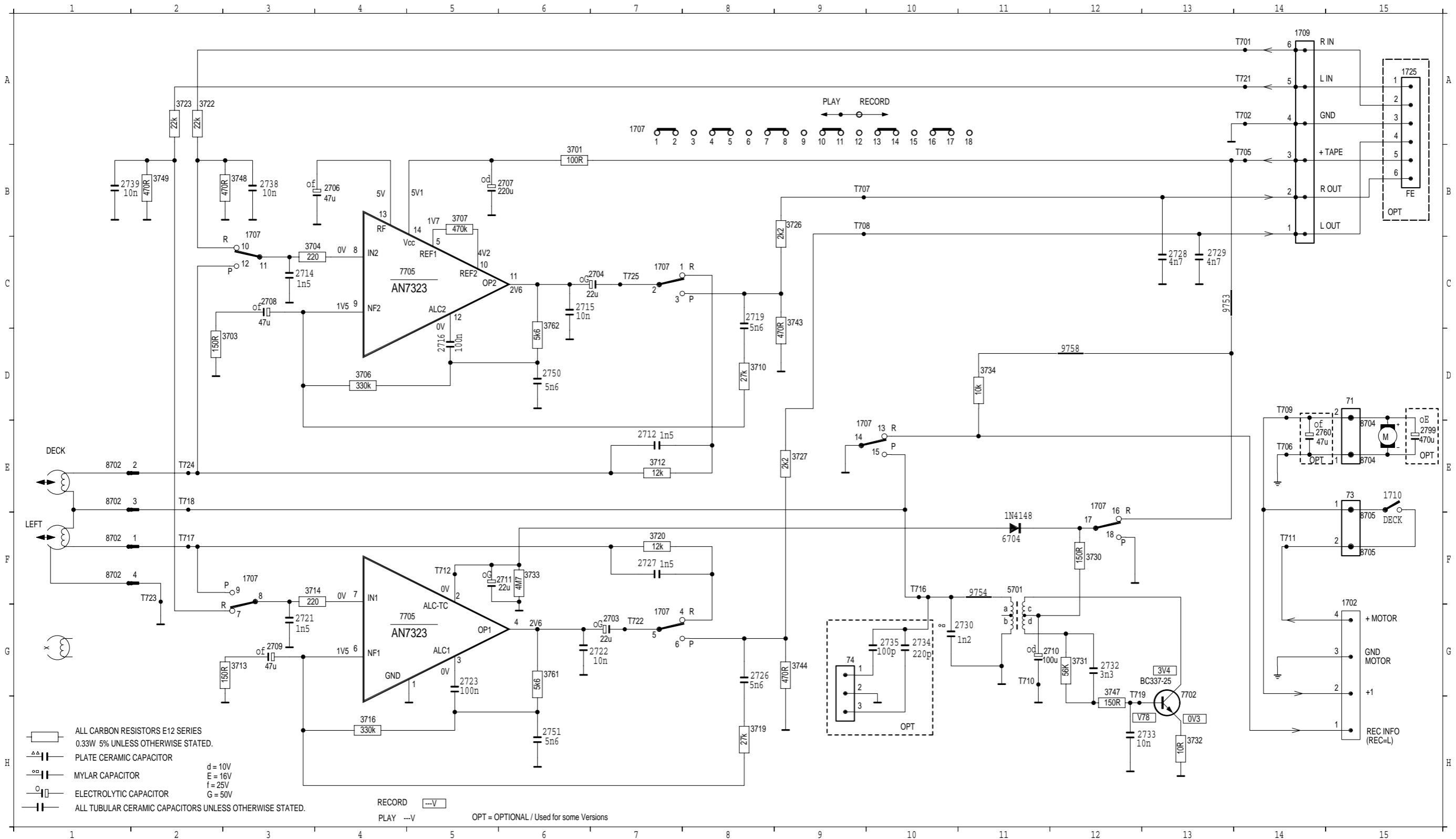

ALL CARBON RESISTORS E12 SERIES
 0.33W 5% UNLESS OTHERWISE STATED.
 PLATE CERAMIC CAPACITOR
 MYLAR CAPACITOR
 ELECTROLYTIC CAPACITOR
 ALL TUBULAR CERAMIC CAPACITORS UNLESS OTHERWISE STATED.

d = 10V
 E = 16V
 f = 25V
 G = 50V

RECORD ---V
 PLAY ---V
 OPT = OPTIONAL / Used for some Versions

RECORDER BOARD - CIRCUIT DIAGRAM

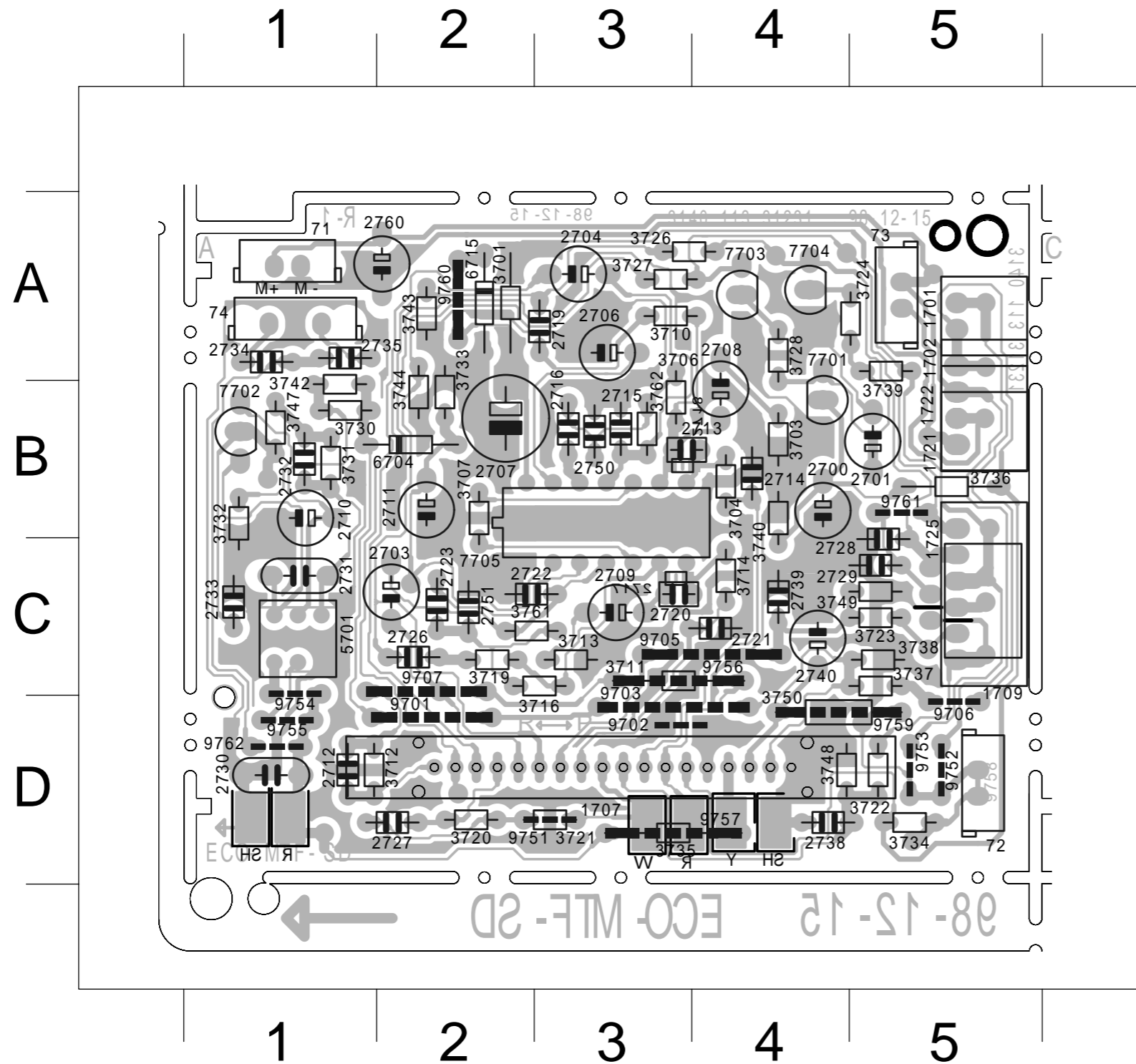

71 A 1	2729 C 5	3733 B 2	9756 C 3
72 D 5	2730 D 1	3734 D 5	9757 D 3
73 A 5	2731 C 1	3735 D 3	9759 D 4
74 A 1	2732 B 1	3736 B 5	9760 A 2
1701 A 5	2733 C 1	3737 C 5	9761 B 5
1702 B 5	2734 A 1	3738 C 5	9762 D 1
1707 D 3	2735 A 1	3739 A 5	T701 C 5
1709 C 5	2738 D 4	3740 B 4	T702 C 5
1721 B 5	2739 C 4	3742 B 1	T705 B 5
1722 B 5	2740 C 4	3743 A 2	T706 B 5
1725 C 5	2750 B 3	3744 B 2	T709 A 5
2700 B 4	2751 C 2	3747 B 1	T710 C 1
2701 B 5	2760 A 2	3748 D 4	T711 B 5
2703 C 2	3701 A 2	3749 C 5	T712 C 2
2704 A 3	3703 B 4	3750 D 4	T713 A 5
2706 A 3	3704 B 4	3761 C 2	T714 D 5
2707 B 2	3706 B 3	3762 B 3	T715 D 5
2708 B 4	3707 B 2	5701 C 1	T716 D 1
2709 C 3	3710 A 3	6704 B 2	T719 B 1
2710 B 1	3711 C 3	6715 A 2	T720 A 5
2711 B 2	3712 D 1	7701 B 4	T721 C 5
2712 D 1	3713 C 3	7702 B 1	T722 C 2
2713 B 3	3714 C 4	7703 A 4	T725 D 2
2714 B 4	3716 C 3	7704 A 4	T7707 A 4
2715 B 3	3719 C 2	7705 B 3	T7708 A 4
2716 B 3	3720 D 2	9701 D 2	
2717 C 3	3721 D 3	9702 D 3	
2718 B 3	3722 D 5	9703 D 3	
2719 A 3	3723 C 5	9705 C 4	
2720 C 3	3724 A 5	9706 D 5	
2721 C 4	3726 A 3	9707 C 2	
2722 C 2	3727 A 3	9751 D 3	
2723 C 2	3728 A 4	9752 D 5	
2726 C 2	3730 B 1	9753 D 5	
2727 D 2	3731 B 1	9754 C 1	
2728 C 5	3732 B 1	9755 D 1	

CASSETTE ADJUSTMENT

Adjustment	Cassette	SK	Deck 1	Measure on	Read on	Adjust with	Adjust to
Azimuth	10 kHz SBC420*	Tape	Play	H/P Jack	mV meter	Left hand Screw R/P head	max.
Motor Speed	3150 kHz SBC420*	Tape	Play	H/P Jack	Wow and flutter meter	Preset in motor	**a

* SBC420 : 4822 397 30071

**a The maximum permissible speed deviation is -3%.
Moreover, the wow and flutter value can be read.

POWER BOARD - CIRCUIT DIAGRAM

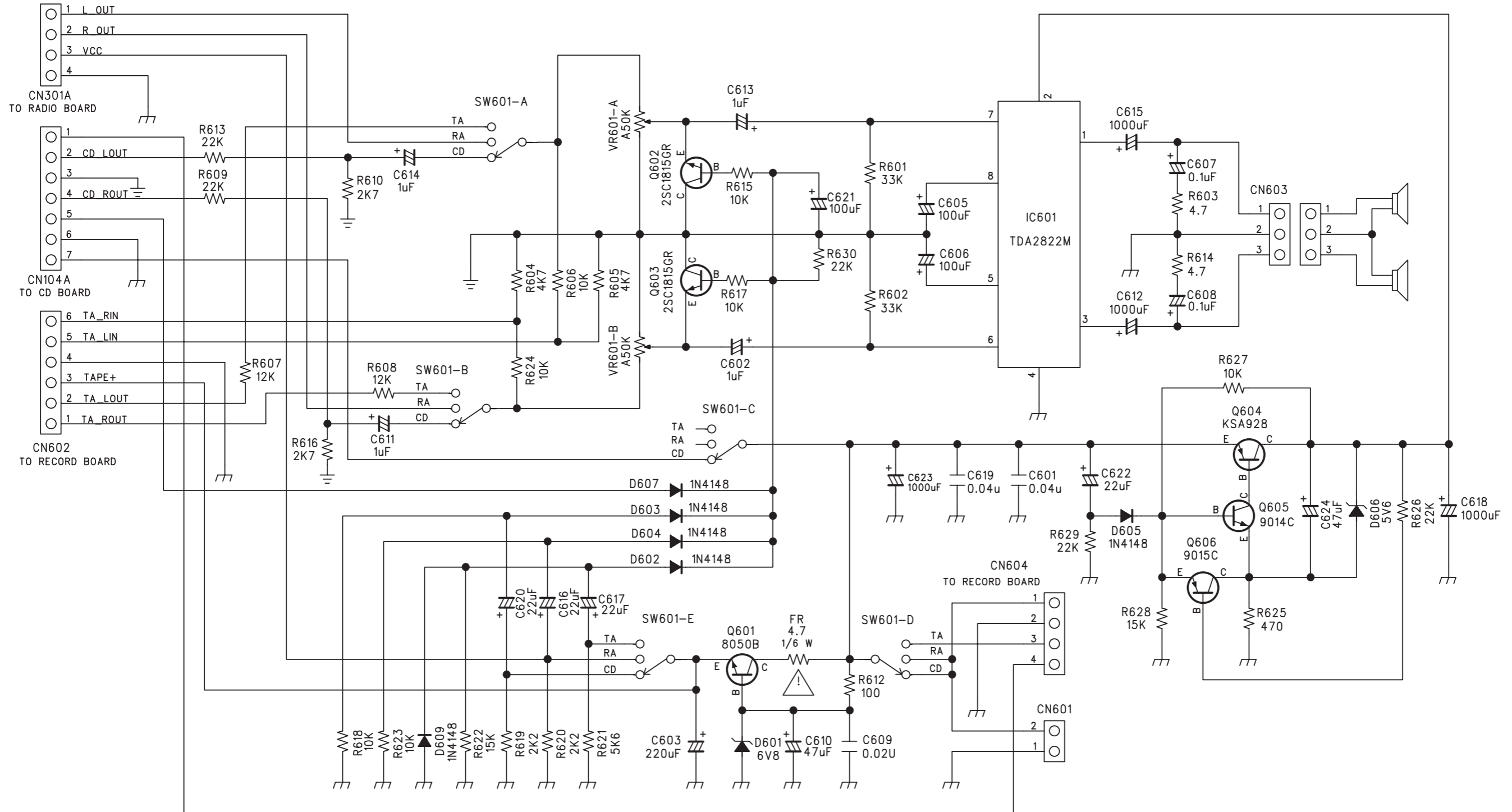

POWER BOARD - LAYOUT DIAGRAM

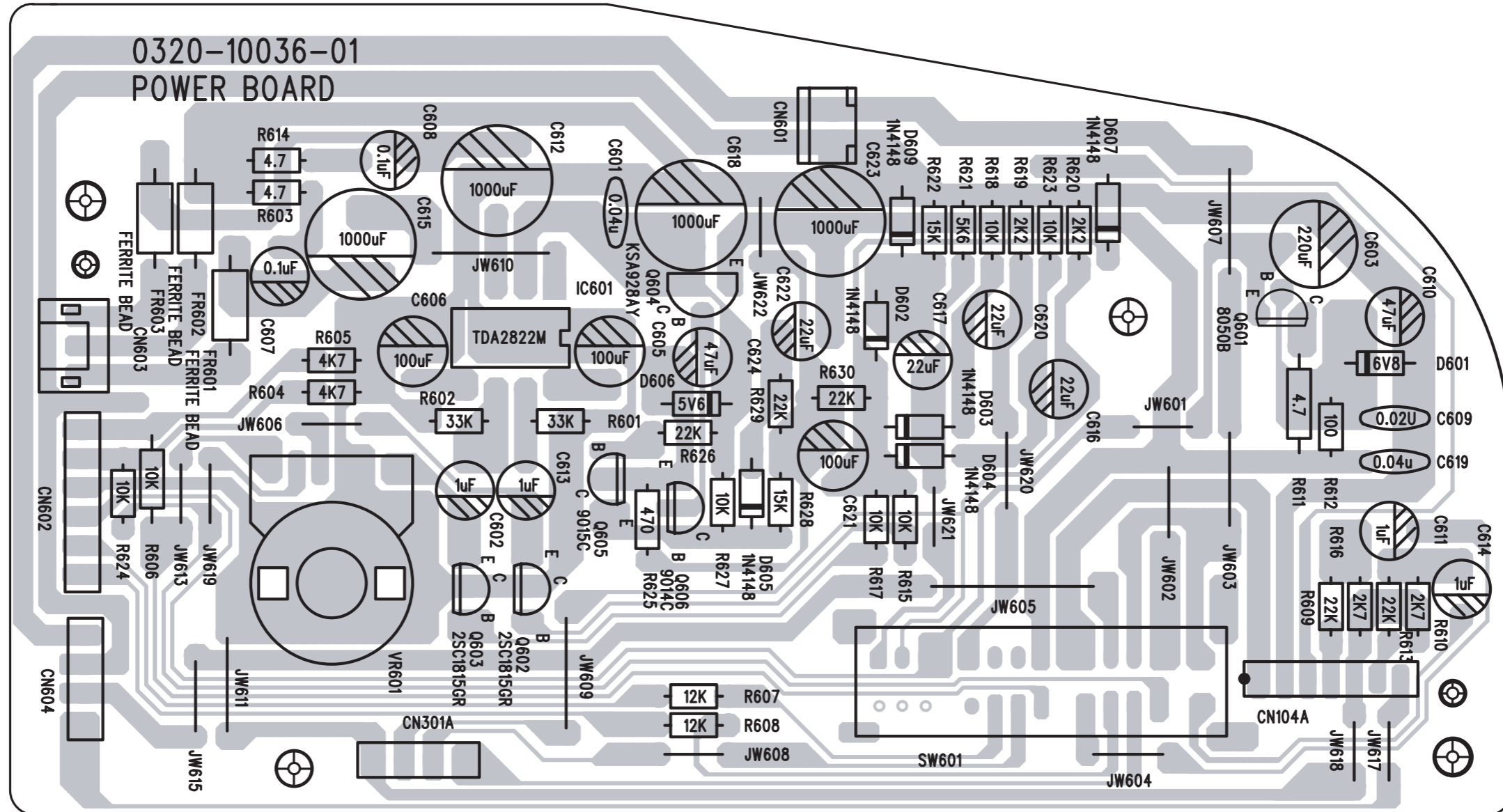

CD
RADIO
TAPE

CD BOARD - CIRCUIT DIAGRAM

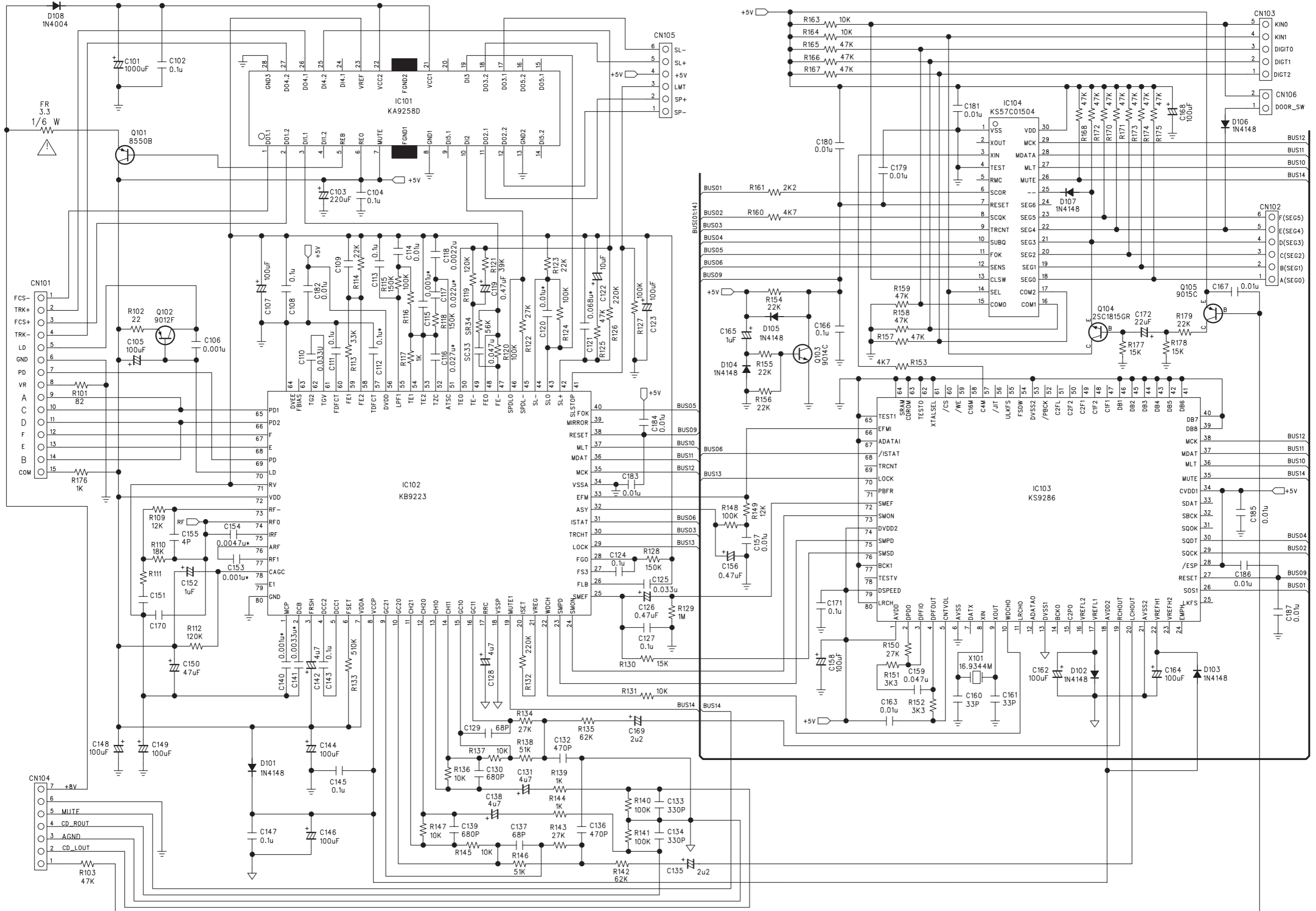

EXPLODED VIEW DIAGRAM - CABINET

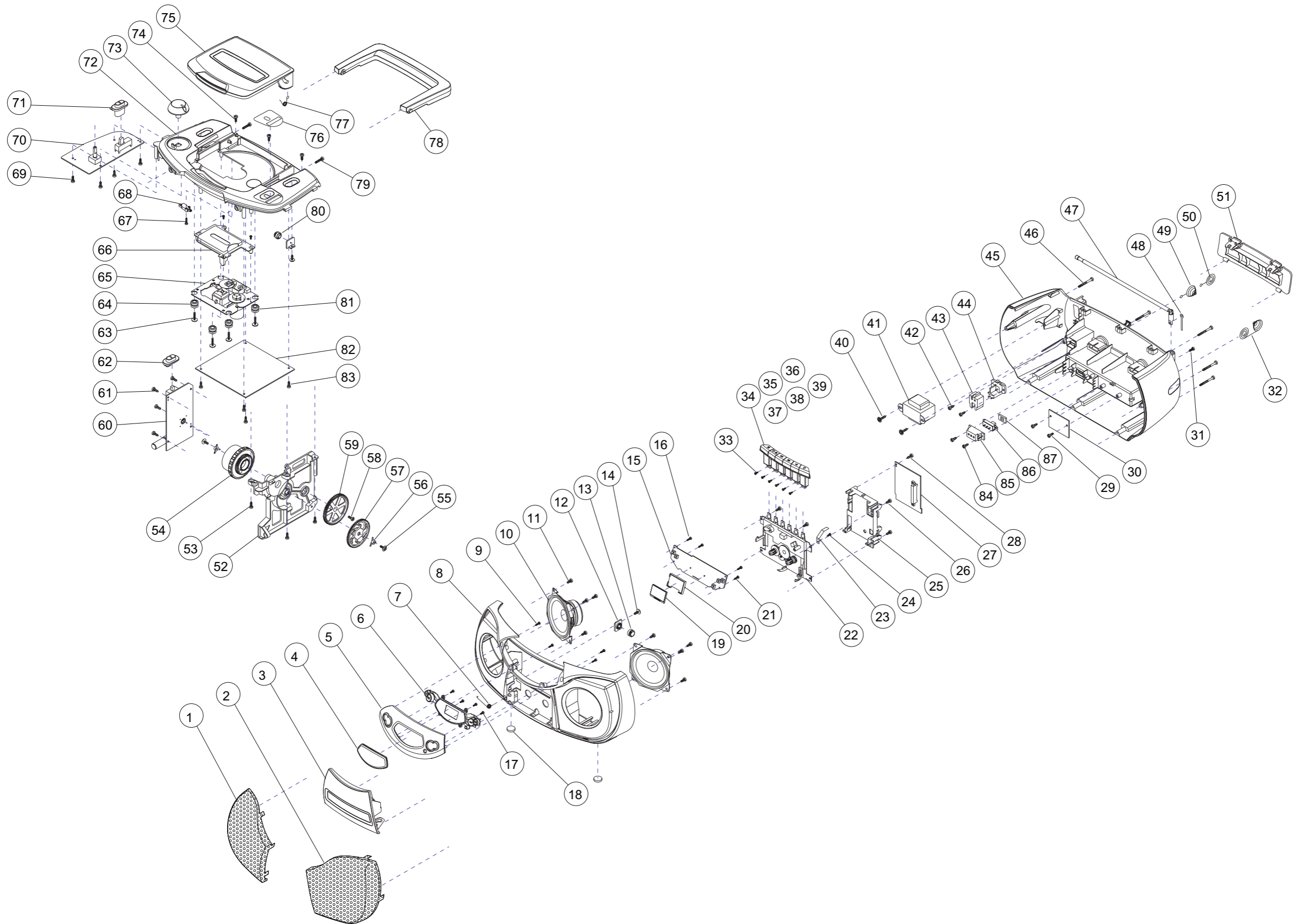

MECHANICAL PARTSLIST

3	3140 114 43640	CASSETTE DOOR
3	9965 000 13811	CASSETTE DOOR (/17)
6	3140 114 43680	CD KNOBS-SET
7	3140 111 01220	CASS. DOOR SPRING
8	3140 117 63140	FRONT CABINET ASSY
13	3140 117 63960	DAMPING GEAR SET
18	3140 114 37490	RUBBER FOOT
22	3140 118 71980	CASS. DECK
	4822 361 21656	MOTOR EG-530AD-9B
	4822 249 40286	R/P HEAD PH-K380-MSI-6A
23	3140 111 20800	SPRING-RECORDING
25	3140 114 20430	BRACKET ECO-MTF-SD
32	3140 111 01280	BATTERY CONTACT (+,-)
34-39	3140 114 43670	CASS KEY
45	3140 117 63390	REAR CABINET ASSY
47	3140 118 71920	TELESCOPIC AERIAL
49	3140 111 01270	BATTERY CONTACT SPRING (-)
50	3140 111 22110	BATTERY CONTACT SPRING (+)
51	3140 114 43630	BATTERY DOOR
54	3140 114 43750	TUNING KNOB
54	9965 000 13812	TUNING KNOB (/17)
57	3140 114 43770	TUNING GEAR
59	3140 114 43760	PVC GEAR
62	3140 114 46000	BAND KNOB
64	4822 529 10386	DAMPER - RUBBER (30 DEG)
65	3103 309 05360	CD DA11B1N DRIVE ASSY
71	3140 114 43700	SOURCE KNOB
72	3140 117 63170	TOP CABINET ASSY
73	3140 114 43660	VOLUME KNOB
75	3140 114 43590	CD DOOR
75	9965 000 13810	CD DOOR (/17)
77	3140 111 01210	CD DOOR SPRING
78	3140 114 43610	HANDLE
80	3140 117 63960	DAMPING GEAR SET
81	4822 529 10387	DAMPER - RUBBER (40 DEG)
	2422 070 98133	MAINS CORD SET
	2422 070 98152	MAINS CORD SET (/17 ONLY)

ELECTRICAL PARTSLIST - RECORDER BOARD (ECO-MTF)**- MISCELLANEOUS -**

1707	4822 277 11504	SWITCH-PUSH 6P2T
------	----------------	------------------

- CAPACITORS -

2703	4822 124 81151	22µF 20% 50V
2704	4822 124 81151	22µF 20% 50V
2706	4822 124 40433	47µF 20% 25V
2707	4822 124 40196	220µF 20% 16V
2708	4822 124 40433	47µF 20% 25V
2709	4822 124 40433	47µF 20% 25V
2710	4822 124 41584	100µF 20% 10V
2711	4822 124 81151	22µF 20% 50V
2712	4822 126 12878	1,5nF 10% 16V
2714	4822 126 12878	1,5nF 10% 16V
2715	4822 121 51387	10nF 20% 16V
2716	2020 561 90365	100nF +80-20% Y5V 50V
2719	4822 126 13098	5,6nF 20% 16V
2721	4822 126 12878	1,5nF 10% 16V
2722	4822 121 51387	10nF 20% 16V
2723	2020 561 90365	100nF +80-20% Y5V 50V
2726	4822 126 13098	5,6nF 20% 16V
2727	4822 126 12878	1,5nF 10% 16V
2728	4822 126 11714	4,7nF 20%
2729	4822 126 11714	4,7nF 20%
2730	2020 300 90561	1,2nF 10% 50V
2732	4822 122 10577	3,3nF 10% 16V
2733	4822 121 51387	10nF 20% 16V
2738	4822 121 51387	10nF 20% 16V
2739	4822 121 51387	10nF 20% 16V
2750	4822 126 13098	5,6nF 20% 16V
2751	4822 126 13098	5,6nF 20% 16V

- RESISTORS -

3701	4822 116 52175	100R 5% 0,5W
3703	4822 116 83868	150R 5% 0,5W
3704	4822 116 83872	220R 5% 0,5W
3706	4822 116 52272	330K 5% 0,5W
3707	4822 116 52285	470K 5% 0,5W
3710	4822 116 52264	27K 5% 0,5W
3712	4822 116 52238	12K 5% 0,5W
3713	4822 116 83868	150R 5% 0,5W
3714	4822 116 83872	220R 5% 0,5W
3716	4822 116 52272	330K 5% 0,5W
3719	4822 116 52264	27K 5% 0,5W
3720	4822 116 52238	12K 5% 0,5W
3722	4822 116 52257	22K 5% 0,5W
3723	4822 116 52257	22K 5% 0,5W
3726	4822 116 52256	2,2K 5% 0,5W

- RESISTORS -

3727	4822 116 52256	2,2K 5% 0,5W
3730	4822 116 83868	150R 5% 0,5W
3731	4822 116 52291	56K 5% 0,5W
3732	4822 116 52182	15R 5% 0,5W
3733	4822 111 30893	4,7M 5% 0,2W
3734	4822 050 21003	10K 1% 0,6W
3743	4822 116 83883	470R 5% 0,5W
3744	4822 116 83883	470R 5% 0,5W
3747	4822 116 83868	150R 5% 0,5W
3748	4822 116 83883	470R 5% 0,5W
3749	4822 116 83883	470R 5% 0,5W
3761	4822 116 52289	5,6K 5% 0,5W
3762	4822 116 52289	5,6K 5% 0,5W

- COILS & FILTERS -

5701	4822 157 10371	BIAS OSC COIL
------	----------------	---------------

- DIODES -

6704	4822 130 30621	1N4148
------	----------------	--------

- IC & TRANSISTORS -

7702	4822 130 40981	BC337-25
7705	4822 209 17498	AN7323

Note: Only these parts mentioned in the list are normal service parts.

ELECTRICAL PARTSLIST - COMBI BOARD**- MISCELLANEOUS -**

1102	4822 265 10925	FFC CONNECTOR 15P
1201	2422 128 02997	SWI TACT 1P
1202	2422 128 02997	SWI TACT 1P
1203	2422 128 02997	SWI TACT 1P
1204	2422 128 02997	SWI TACT 1P
1205	2422 128 02997	SWI TACT 1P
1302	8240 009 50910	SWITCH-SLIDE 4P3T
1305	3140 114 50050	FERRITE BAR 80MM
1602	8240 009 50930	SWITCH-SLIDE 6P3T

- CAPACITORS -

2101	4822 124 81144	1000 μ 20% 16V
2102	4822 126 12333	100nF 20% Y5R 50V
2103	4822 124 40196	220 μ F 20% 16V
2104	4822 126 12333	100nF 20% Y5R 50V
2105	4822 124 41584	100 μ F 20% 10V
2106	5322 122 32331	1nF 10% 100V
2107	4822 124 41584	100 μ F 20% 10V
2108	4822 126 12333	100nF 20% Y5R 50V
2110	5322 121 42489	33nF 5% 250V
2111	4822 126 12333	100nF 20% Y5R 50V
2112	5322 121 42386	100nF 5% 63V
2113	4822 126 12333	100nF 20% Y5R 50V
2114	4822 122 30043	10nF 80% 63V
2115	5322 122 32331	1nF 10% 100V
2116	4822 121 70676	27P 10% 50V
2117	4822 121 41856	22nF 5% 250V
2118	5322 122 32818	2,2nF 10% 100V
2119	4822 124 41407	0,47 μ F 20% 63V
2120	4822 121 41857	10nF 5% 250V
2121	5322 121 42465	68nF 5% 63V
2122	4822 124 40248	10 μ F 20% 63V
2123	4822 124 41584	100 μ F 20% 10V
2124	5322 121 42386	100nF 5% 63V
2125	5322 121 42489	33nF 5% 250V
2126	4822 124 41407	0,47 μ F 20% 63V
2127	4822 126 12333	100nF 20% Y5R 50V
2128	4822 124 40769	4,7 μ F 20% 100V
2129	4822 122 31349	68pF 2% 100V
2130	4822 126 13461	680pF 10% 50V
2131	4822 124 40769	4,7 μ F 20% 100V
2132	5322 122 32311	470pF 10% 100V
2133	4822 126 13512	330pF 10% 50V
2134	4822 126 13512	330pF 10% 50V
2135	4822 124 22652	2,2 μ F 20% 50V
2136	5322 122 32311	470pF 10% 100V

- CAPACITORS -

2137	4822 122 31349	68pF 2% 100V
2138	4822 124 40769	4,7 μ F 20% 100V
2139	4822 126 13461	680pF 10% 50V
2140	4822 121 43897	1nF 5% 400V
2141	4822 121 42687	3,3nF 10% 63V
2142	4822 124 40769	4,7 μ F 20% 100V
2143	4822 126 12333	100nF 20% Y5R 50V
2144	4822 124 41584	100 μ F 20% 10V
2145	4822 126 12333	100nF 20% Y5R 50V
2146	4822 124 41584	100 μ F 20% 10V
2147	4822 126 12333	100nF 20% Y5R 50V
2148	4822 124 41584	100 μ F 20% 10V
2149	4822 124 41584	100 μ F 20% 10V
2150	4822 124 40433	47 μ F 20% 25V
2152	4822 124 21913	1 μ F 20% 63V
2153	4822 121 43897	1nF 5% 400V
2154	4822 121 43856	4.7nF 5% 250V
2155	4822 122 31822	4,7pF 0,25pF 100V
2156	4822 124 41407	0,47 μ F 20% 63V
2157	4822 122 30043	10nF 80% 63V
2158	4822 124 41584	100 μ F 20% 10V
2159	4822 122 33449	47nF 30% 50V
2160	4822 126 13785	33pF 5% NP0 50V
2161	4822 126 13785	33pF 5% NP0 50V
2162	4822 124 41584	100 μ F 20% 10V
2163	4822 122 30043	10nF 80% 63V
2164	4822 124 41584	100 μ F 20% 10V
2165	4822 124 21913	1 μ F 20% 63V
2166	4822 126 12333	100nF 20% Y5R 50V
2167	4822 122 30043	10nF 80% 63V
2168	4822 124 41584	100 μ F 20% 10V
2169	4822 124 22652	2,2 μ F 20% 50V
2171	4822 126 12333	100nF 20% Y5R 50V
2172	4822 122 30043	10nF 80% 63V
2178	4822 122 33449	47nF 30% 50V
2179	4822 122 30043	10nF 80% 63V
2180	4822 122 30043	10nF 80% 63V
2181	4822 122 30043	10nF 80% 63V
2182	4822 122 30043	10nF 80% 63V
2183	4822 122 30043	10nF 80% 63V
2184	4822 122 30043	10nF 80% 63V
2185	4822 122 30043	10nF 80% 63V
2186	4822 122 30043	10nF 80% 63V
2187	4822 122 30043	10nF 80% 63V
2190	4822 126 12333	100nF 20% Y5R 50V
2300	3140 118 50110	PVC 160/82+20X2
2301	4822 124 40769	4,7 μ F 20% 100V
2302	5322 122 32331	1nF 10% 100V
2303	4822 121 41857	10nF 5% 250V
2304	4822 121 41857	10nF 5% 250V

ELECTRICAL PARTSLIST - COMBI BOARD**- CAPACITORS -**

2305	4822 124 21913	1µF 20% 63V
2306	5322 121 42386	100nF 5% 63V
2307	5322 121 42386	100nF 5% 63V
2308	4822 124 41407	0,47µF 20% 63V
2309	4822 124 21913	1µF 20% 63V
2310	4822 124 21913	1µF 20% 63V
2311	5322 122 32331	1nF 10% 100V
2312	4822 122 33524	22pF 5% 50V
2314	4822 124 22652	2,2µF 20% 50V
2315	4822 122 31822	4,7pF 0,25pF 100V
2316	4822 126 12814	24pF 5% N220 50V
2317	4822 122 33524	22pF 5% 50V
2318	4822 126 12333	100nF 20% Y5R 50V
2319	4822 124 40196	220µF 20% 16V
2321	4822 122 30043	10nF 80% 63V
2322	4822 122 30103	22nF 80% 63V
2323	4822 122 32185	10pF 2% 100V
2324	4822 122 31822	4,7pF 0,25pF 100V
2325	5322 121 42489	33nF 5% 250V
2326	5322 121 42489	33nF 5% 250V
2327	4822 122 30103	22nF 80% 63V
2329	4822 124 21913	1µF 20% 63V
2330	4822 126 12726	47pF 5% NP0 50V
2331	4822 126 12333	100nF 20% Y5R 50V
2601	4822 122 33449	47nF 30% 50V
2602	4822 124 21913	1µF 20% 63V
2603	4822 124 40196	220µF 20% 16V
2605	4822 124 41584	100µF 20% 10V
2606	4822 124 41584	100µF 20% 10V
2607	5322 121 42386	100nF 5% 63V
2608	5322 121 42386	100nF 5% 63V
2609	4822 122 30103	22nF 80% 63V
2610	4822 124 40433	47µF 20% 25V
2611	4822 124 21913	1µF 20% 63V
2612	4822 124 81144	1000µF 20% 16V
2613	4822 124 21913	1µF 20% 63V
2614	4822 124 21913	1µF 20% 63V
2615	4822 124 81144	1000µ 20% 16V
2616	4822 124 81151	22µF 20% 50V
2617	4822 124 81151	22µF 20% 50V
2618	4822 124 81144	1000µF 20% 16V
2619	4822 122 33449	47nF 30% 50V
2620	4822 124 81151	22µF 20% 50V
2621	4822 124 81151	22µF 20% 50V
2622	4822 124 81151	22µF 20% 50V
2623	4822 124 81144	1000µF 20% 16V
2624	4822 124 40433	47µF 20% 25V
2700	4822 126 12333	100nF 20% Y5R 50V
2701	4822 126 12333	100nF 20% Y5R 50V
2702	4822 126 12333	100nF 20% Y5R 50V

- CAPACITORS -

2703	4822 122 30103	22nF 80% 63V
2705	4822 124 81151	22µF 20% 50V

- RESISTORS -

3101	4822 116 52202	82R 5% 0,5W
3102	4822 116 52186	22R 5% 0,5W
3109	4822 116 52238	12K 5% 0,5W
3110	4822 116 52251	18K 5% 0,5W
3112	4822 116 52239	120K 5% 0,5W
3113	4822 050 23303	33K 1% 0,6W
3114	4822 116 52257	22K 5% 0,5W
3115	4822 116 52245	150K 5% 0,5W
3116	4822 116 52234	100K 5% 0,5W
3117	4822 050 11002	1K 1% 0,4W
3118	4822 116 52245	150K 5% 0,5W
3119	4822 116 52239	120K 5% 0,5W
3120	4822 116 52234	100K 5% 0,5W
3121	4822 116 83882	39K 5% 0,5W
3122	4822 116 52264	27K 5% 0,5W
3123	4822 116 52257	22K 5% 0,5W
3124	4822 116 52234	100K 5% 0,5W
3125	4822 116 83884	47K 5% 0,5W
3126	4822 116 83874	220K 5% 0,5W
3127	4822 116 52234	100K 5% 0,5W
3128	4822 116 52245	150K 5% 0,5W
3129	4822 116 83866	1M 5% 0,5W
3130	4822 116 52244	15K 5% 0,5W
3132	4822 116 83874	220K 5% 0,5W
3133	4822 116 52292	560K 5% 0,5W
3134	4822 116 52264	27K 5% 0,5W
3135	4822 116 52297	68K 5% 0,5W
3136	4822 050 21003	10K 1% 0,6W
3137	4822 050 21003	10K 1% 0,6W
3138	4822 116 52291	56K 5% 0,5W
3140	4822 116 52234	100K 5% 0,5W
3141	4822 116 52234	100K 5% 0,5W
3142	4822 116 52297	68K 5% 0,5W
3143	4822 116 52264	27K 5% 0,5W
3145	4822 050 21003	10K 1% 0,6W
3146	4822 116 52291	56K 5% 0,5W
3147	4822 050 21003	10K 1% 0,6W
3148	4822 116 52234	100K 5% 0,5W
3149	4822 116 52238	12K 5% 0,5W
3150	4822 116 52264	27K 5% 0,5W
3151	4822 116 52269	3,3K 5% 0,5W
3152	4822 116 52269	3,3K 5% 0,5W
3153	4822 116 52283	4,7K 5% 0,5W
3154	4822 116 52257	22K 5% 0,5W
3155	4822 116 52257	22K 5% 0,5W

ELECTRICAL PARTSLIST - COMBI BOARD**- RESISTORS -**

3156	4822 116 52257	22K 5% 0,5W
3157	4822 116 83884	47K 5% 0,5W
3158	4822 116 83884	47K 5% 0,5W
3159	4822 116 83884	47K 5% 0,5W
3163	4822 050 21003	10K 1% 0,6W
3164	4822 050 21003	10K 1% 0,6W
3165	4822 116 83884	47K 5% 0,5W
3166	4822 116 83884	47K 5% 0,5W
3167	4822 116 83884	47K 5% 0,5W
3168	4822 116 83884	47K 5% 0,5W
3170	4822 116 83884	47K 5% 0,5W
3171	4822 116 83884	47K 5% 0,5W
3172	4822 116 83884	47K 5% 0,5W
3173	4822 116 83884	47K 5% 0,5W
3174	4822 116 83884	47K 5% 0,5W
3175	4822 116 83884	47K 5% 0,5W
3176	4822 050 11002	1K 1% 0,4W
3177	4822 116 52244	15K 5% 0,5W
3178	4822 116 52251	18K 5% 0,5W
3179	4822 116 52291	56K 5% 0,5W
3180	4822 052 10338	3,3R 5% 0,33W
3181	4822 116 52244	15K 5% 0,5W
3301	4822 116 52269	3,3K 5% 0,5W
3302	4822 116 52219	330R 5% 0,5W
3304	4822 050 23303	33K 1% 0,6W
3305	4822 116 52219	330R 5% 0,5W
3329	4822 116 52269	3,3K 5% 0,5W
3330	4822 116 52243	1,5K 5% 0,5W
3331	4822 116 52269	3,3K 5% 0,5W
3332	4822 116 52243	1,5K 5% 0,5W
3333	4822 116 52234	100K 5% 0,5W
3334	4822 116 52234	100K 5% 0,5W
3335	4822 116 52186	22R 5% 0,5W
3401	8240 009 50880	POT. 50KB
3601	4822 050 23303	33K 1% 0,6W
3602	4822 050 23303	33K 1% 0,6W
3603	4822 052 10478	4,7R 5% 0,33W
3604	4822 116 52283	4,7K 5% 0,5W
3605	4822 116 52283	4,7K 5% 0,5W
3606	4822 050 21003	10K 1% 0,6W
3607	4822 116 52251	18K 5% 0,5W
3608	4822 116 52251	18K 5% 0,5W
3609	4822 116 52257	22K 5% 0,5W
3610	4822 116 52276	3,9K 5% 0,5W
3611	4822 050 24708	4,7R 5% 0,16W
3612	4822 116 52175	100R 5% 0,5W
3613	4822 116 52257	22K 5% 0,5W
3614	4822 050 24708	4,7R 5% 0,16W
3615	4822 050 21003	10K 1% 0,6W
3616	4822 116 52276	3,9K 5% 0,5W

- RESISTORS -

3617	4822 050 21003	10K 1% 0,6W
3618	4822 050 21003	10K 1% 0,6W
3619	4822 116 52256	2,2K 5% 0,5W
3620	4822 116 52256	2,2K 5% 0,5W
3621	4822 116 52256	2,2K 5% 0,5W
3622	4822 050 21003	10K 1% 0,6W
3623	4822 050 21003	10K 1% 0,6W
3624	4822 050 21003	10K 1% 0,6W
3625	4822 116 83883	470R 5% 0,5W
3626	4822 116 52257	22K 5% 0,5W
3627	4822 050 21003	10K 1% 0,6W
3628	4822 116 52245	150K 5% 0,5W
3629	4822 116 52257	22K 5% 0,5W

- COILS & FILTERS -

5100	8240 009 52000	RES CER 16MHZ93
5155	4822 526 10704	FERRITE BEAD 100MHZ
5301	4822 242 71139	SFU468B
5302	4822 242 70665	SFE10,7MS3-A
5311	8240 009 51080	IFT MW DISCRIMINATOR
5312	8240 009 51070	IFT MW
5313	8240 009 51090	IFT FM DETECTOR
5321	8240 009 51410	COIL SPRING D5 3.5T
5322	2422 549 45371	FM OSC COIL
5323	8240 009 51400	FM BPF
5325	8240 009 51370	COIL - MW ANT
5601	4822 526 10704	FERRITE BEAD 100MHZ
5602	4822 526 10704	FERRITE BEAD 100MHZ
5603	4822 526 10704	FERRITE BEAD 100MHZ

- DIODES -

6101	4822 130 30621	1N4148
6102	4822 130 30621	1N4148
6103	4822 130 30621	1N4148
6104	4822 130 30621	1N4148
6105	4822 130 30621	1N4148
6106	4822 130 30621	1N4148
6107	4822 130 30621	1N4148
6108	4822 130 31878	1N4003G
6201	4822 130 30621	1N4148
6202	4822 130 30621	1N4148
6203	4822 130 30621	1N4148
6301	4822 130 30621	1N4148
6302	4822 130 30621	1N4148
6601	4822 130 34278	BZX79-B6V8
6602	4822 130 30621	1N4148

ELECTRICAL PARTSLIST - COMBI BOARD**SUPPLY BOARD & MISCELLANEOUS****- DIODES -**

6603	4822 130 30621	1N4148
6604	4822 130 30621	1N4148
6605	4822 130 30621	1N4148
6606	4822 130 34173	BZX79-B5V6
6607	4822 130 30621	1N4148
6609	4822 130 30621	1N4148

- IC & TRANSISTORS -

7101	4822 130 44503	BC547C
7102	4822 130 44503	BC547C
7103	4822 130 41327	BC327-40
7104	4822 130 41327	BC327-40
7105	4822 130 42231	BC557C
7111	4822 209 12794	KA9258D
7112	8240 009 50960	KB9223
7113	8240 009 50970	KS9286
7114	8240 009 50990	KS57C01504-NV15
7201	3140 110 51500	LCD PANEL
7301	8240 009 50950	KA22902
7501	4822 130 40855	BC337
7600	5322 209 83002	TDA2822M
7601	4822 130 40855	BC337
7602	4822 130 40855	BC337
7603	5322 130 44593	BC369
7605	4822 130 42231	BC557C
7606	4822 130 44503	BC547C

- MISCELLANEOUS -

1004	8240 009 50900	SPEAKER 3" 8 OHM
1005	8240 009 50900	SPEAKER 3" 8 OHM
1006	⚠ 3140 118 33570	TFM POW 230V /00/05/10
1006	⚠ 3140 118 33580	TFM POW 120/230V /01
1006	⚠ 9965 000 13813	TFM POW 120V /17
1007	⚠ 2422 030 00333	AC SOCKET
1007	⚠ 9965 000 11861	AC SOCKET (/17 ONLY)
1008	⚠ 4822 277 21794	VOLT SEL. SWITCH
1010	⚠ 4822 070 31252	FUSE 1.25A
1110	⚠ 8240 009 51360	CHOKE COIL
1200	8240 009 51700	CD DOOR SWITCH
8202	4822 320 12178	FFC CABLE 15P - 65MM

- CAPACITORS -

2801	4822 122 30103	22nF 80% 63V
2802	4822 122 30103	22nF 80% 63V
2803	4822 122 30103	22nF 80% 63V
2804	4822 122 30103	22nF 80% 63V
2805	4822 124 40784	3300µF 20% 16V

- DIODES -

6801	4822 130 31878	1N4003G
6802	4822 130 31878	1N4003G
6803	4822 130 31878	1N4003G
6804	4822 130 31878	1N4003G

Note: Only these parts mentioned in the list are normal service parts.