

ONKYO SERVICE MANUAL

AV RECEIVER MODEL HT-R330

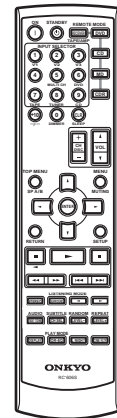
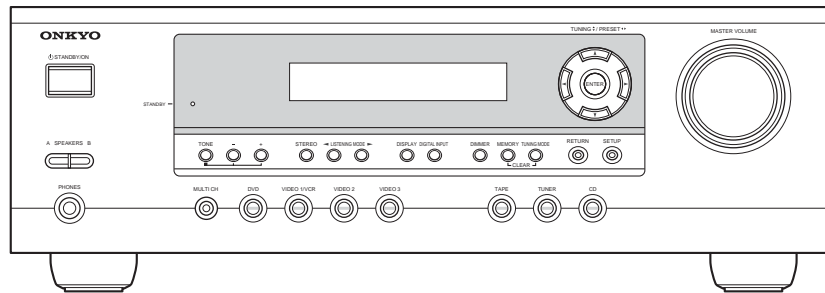

RC-606S

Silver model

S MDD, S MDC	120V AC, 60Hz
S MWT	120/220-230V AC, 50/60Hz
S MPP	230-240V AC, 50Hz

SAFETY-RELATED COMPONENT WARNING!!

COMPONENTS IDENTIFIED BY MARK  ON THE SCHEMATIC DIAGRAM AND IN THE PARTS LIST ARE CRITICAL FOR RISK OF FIRE AND ELECTRIC SHOCK. REPLACE THESE COMPONENTS WITH ONKYO PARTS WHOSE PART NUMBERS APPEAR AS SHOWN IN THIS MANUAL.

MAKE LEAKAGE-CURRENT OR RESISTANCE MEASUREMENTS TO DETERMINE THAT EXPOSED PARTS ARE ACCEPTABLY INSULATED FROM THE SUPPLY CIRCUIT BEFORE RETURNING THE APPLIANCE TO THE CUSTOMER.

SPECIFICATIONS

Amplifier Section

Power Output	North American: 100 W + 100 W (8Ω , 20Hz - 20kHz, FTC)
2 channel driven:	European: 100 W + 100 W (8Ω , 1kHz, DIN) Asian: 120 W + 120 W (8Ω , 1kHz, JEITA)
Dynamic Power	230 W + 230 W (3 Ω , Front) / 170 W + 170 W (4 Ω , Front) / 115 W + 115 W (8 Ω , Front)
THD (Total Harmonic Distortion)	0.08% (Power Rated)
Damping Factor	60 (Front, 1kHz, 8 Ω)
Input Sensitivity and Impedance	200 mV/ 47 k Ω (LINE)
Output Level and Impedance	200 mV/ 470 Ω (REC OUT)
Frequency Response	10 Hz – 100 kHz/ +1 dB -3 dB (Direct mode)
Tone Control	±10 dB, 50 Hz (BASS) / ±10 dB, 20 kHz (TREBLE)
Signal to Noise Ratio	100 dB (LINE IHF-A)
Speaker Impedance	8Ω – 16Ω

Video Section

Input Sensitivity/Output Level and Impedance	1 Vp-p /75Ω (Composite)
--	-------------------------

Tuner Section

■ FM

Tuning Frequency Range	North American: 87.5 MHz – 107.9 MHz / European: 87.5 MHz – 108.0 MHz Asian: 87.5 MHz – 108.0 MHz
Usable Sensitivity	Stereo: 17.2 dBf 2 μV(75Ω IHF) / Mono: 11.2 dBf 1μV(75Ω IHF)
Signal to Noise Ratio	Stereo: 70 dB (IHF-A) / Mono: 76 dB (IHF-A)
THD	Stereo: 0.3% (1kHz) / Mono: 0.2% (1kHz)
Frequency Response	30 Hz – 15 kHz / ±1 dB
Stereo Separation	45 dB (1kHz)

■ AM

Tuning Frequency Range	North American: 530 kHz – 1710 kHz / European: 522 kHz – 1611 kHz Asian: 530/522 kHz – 1710/1611 kHz
Usable Sensitivity	30 μV
Signal to Noise Ratio	40 dB
THD	0.70%

General

Power Supply	North American: AC 120 V, 60 Hz / Australian and European: AC 230-240 V, 50 Hz Others: AC 120 – 220/230 V, 50/60 Hz / AC 230 – 240 V, 50 Hz
Power Consumption	North American: 5.5 A / Others: 380 W
Stand-by Power Consumption	North American: 0.1 W/ European: 0.2 W / Others: 0.5 W
Dimensions (W x H x D)	435 x 150 x 369 mm 17-1/8" x 5-7/8" x 14-1/2"
Weight	North American and European: 8.8 kg 19.4 lbs. Others: 9.6 kg, 19.0 lbs.

■ Video inputs

Composite	DVD, VIDEO1, VIDEO2, VIDEO3
-----------	-----------------------------

■ Video outputs

Composite	MONITOR, VIDEO1
-----------	-----------------

■ Audio inputs

Digital Inputs	Optical: 1 / Coaxial: 1
Analog Inputs	DVD(MULTICHANNEL), VIDEO1, VIDEO2, VIDEO3, TAPE, CD
Multichannel Inputs	6

■ Audio outputs

Analog Outputs	TAPE, VIDEO1
Speaker Outputs	SP-A (L, R, C, SL, SR, SW) + SP-B (L, R)
Phones	1

SERVICE PROCEDURE

1. Replacing the fuses

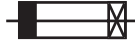

This symbol located near the fuse indicates that the fuse used is slow operating type. For continued protection against fire hazard, replace with same type fuse. For fuse rating, refer to the marking adjacent to the symbol.

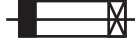

Ce symbole indique que le fusible utilisé est à lent. Pour une protection permanente, n'utiliser que des fusibles de même type. Ce dernier est indiqué là où le présent symbole est apposé.

REF NO.	PART NAME	DESCRIPTION	PART NO.	REMARKS
F6901	FUSE	8A-UL	252198	!
F6901 or	FUSE	8A-T/UL-ST2	252261	!
F6902	FUSE	8A-UL	252198	!
F6902 or	FUSE	8A-T/UL-ST2	252261	!
F901	FUSE	6.3A-UL/T-237	252166	!, <DD, DC>
F901 or	FUSE	6.3A-T/UL-ST2	252260	!, <DD, DC>
F901	FUSE	3.15A-SE-EAK FUSE	252076	!, <WT>
F901 or	FUSE	3.15A-SE-TL250V	252242	!, <WT>
F901 or	FUSE	3.15A-SE-TL250V	252276	!, <WT>
F902	FUSE	3.15A-SE-EAK FUSE	252076	!, <PP, WT>
F902 or	FUSE	3.15A-SE-TL250V	252242	!, <PP, WT>
F902 or	FUSE	3.15A-SE-TL250V	252276	!, <PP, WT>

<Notes>

<DD> : USA model only
 <DC> : Canadian model Only
 <WT> : World wide model Only
 <PP> : European model Only

2. Safety-check out

(Only U.S.A. model)

After correcting the original service problem perform the following safety check before releasing the set to the customer
 Connect the insulating-resistance tester between the plug of power supply cord and terminal GND on the back panel.
 Specifications: More than 10Mohm at 500V

3. To initialize the unit

1. Press and the hold down the VIDEO 1/VCR button, then press the STANDBY/ON button when the unit is Power on.
2. After " Clear " is displayed, the preset memory and each mode stored in the memory, are initialized and will return to the factory settings.

4. To check version of microprocessor

<Note>

Main microprocessor Q701 only.

1. Press and the hold down the DISPLAY button, then press the STANDBY/ON button when the unit is Power on.
 Version is displayed on FL display only for 3 seconds.

Ex.

Ver. 1.01/05305a

2. Press the STANDBY/ON button to Power off.

5. Memory Backup

The AV receiver uses a battery-less memory backup system in order to retain radio presets and other settings when it's unplugged or in the case of a power failure.

Although no batteries are required, the AV receiver must be plugged into an AC outlet in order to charge the backup system. Once it has been charged, the AV receiver will retain the settings for several weeks, although this depends on the environment and will be shorter in humid climates.

OPERATION CHECK-1

SPEAKER PROTECT-1 (DC VOLTAGE DETECTION)

[When]

1. Exchange power transistors (Q6050 - Q6065).
2. Exchange amplifier PC board ass'y (NAAF-8523).

[Procedure]

<Note>

No load. No input.

1. Press and the hold down the CD button , then press the STANDBY/ON button when the unit is Power ON.
" Test - _ " is displays it only for 5 seconds.

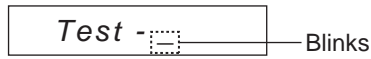

2. Press the VIDEO 3 button, while the character of " Test - _ " is displayed.
Unit will be in the state of " Test-4-00 ".

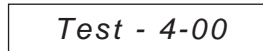

3. Repeatedly press TONE+ button until the character of " Test-4-21 " is displayed.

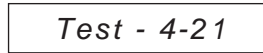

Checking the operation starts automatically as follows.

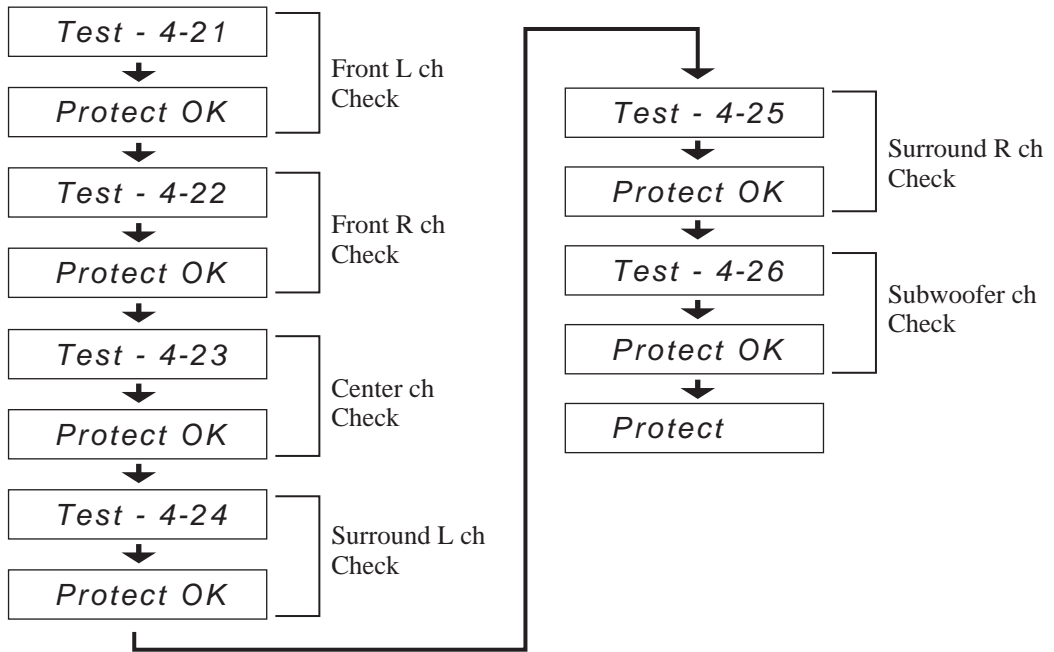

If all channel are OK, the character of " Test - 4 - 35 " is displayed.

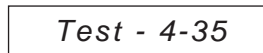

4. Press the STANDBY/ON button.



OPERATION CHECK-2

SPEAKER PROTECT-2 (CURRENT DETECTION)

[When]

1. Exchange power transistors (Q6050 - Q6065).
2. Exchange amplifier PC board ass'y (NAAF-8523).

[Procedure]

<Note>

No input.

Do not check two or more channels at the same time.

Do not connect dummy load to speaker terminals for seconds 2 or more.

1. Press and the hold down the CD button , then press the STANDBY/ON button when the unit is Power ON.
" *Test - _* " is displays it only for 5 seconds.

Test - _ Blinks

2. Press the VIDEO 3 button, while the character of " *Test - _* " is displayed.
Unit will be in the state of " *Test-4-00* ".

Test - 4-00

3. Repeatedly press TONE+ button until the character of " *Test-4-35* " is displayed.

Test - 4-35

4. Connect the Dummy load of 3 ohms to the Front Lch speakers terminal.
At this time, check the speaker relay is not turned off.

Test - 4-35

5. Connect the dummy load of 1 ohm to the Front Lch speakers terminal.
At that time, you check the speaker relay is turned off and " *Protect* " is displayed.

Protect

Disconnect the dummy load at once when check the display of " *Protect* ".

Test - 4-35

6. Check other channels according to the same procedure.

7. Press the STANDBY/ON button.

Clear → Turn off

OPERATION CHECK-3

CONTROL OF POWER SUPPLY (OUTPUT SENSOR AND THERMAL SENSOR)

[When]

1. Exchange power transistors (Q6050 - Q6065).
2. Exchange power amplifier PC board ass'y (NAAF-8523).
3. Exchange thermal sensor PC board ass'y (NAETC-8526).

[Procedure]

<Note>

No output. No input.

Output sensor

1. Press and the hold down the CD button , then press the STANDBY/ON button when the unit is Power ON.
" Test - _ " is displays it only for 5 seconds.

Test -  — Blinks

2. Press the VIDEO 3 button, while the character of " Test - _ " is displayed.
Unit will be in the state of " Test-4-00 ".

Test - 4-00

3. Repeatedly press TONE+ button until the character of " Test-4-37 " is displayed.

Test - 4-37

4. Adjust the MASTER VOLUME to Max. position.
At this time, check the character of " FM STEREO " displayed.
And, check relay RL6901 and RL6902 are turned off in 2 - 3 seconds.

Test - 4-37 

5. Press the STANDBY/ON button.

Clear  Turn off

Thermal sensor

1. Press and hold down the DISPLAY button, then press the STANDBY/ON button when the unit is power ON.
" Ver. 0.50/05131a " is displays it only for 2 seconds.

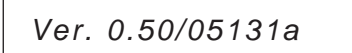
<Ex.> 

2. Press the TONE button, while the character of " Ver.0.50/05131a " is displayed.

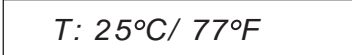
<Ex.> 

3. Check the displayed temperature is +/-20°C of the ambient temperatures.

4. Press STANDBY/ON button.

Clear  Turn off

OPERATION CHECK-4

DSP DEBUG MODE

Check the operation of the circuit around DSP by the display in this mode.
This information helps to pursue the faulty point.

To set in DSP debug mode

1. Press and hold down the DISPLAY button, then press the STANDBY/ON button when the unit is power ON.
" Ver. 0.50/05131a " is displays it only for 2 seconds.

<Ex.> Ver. 0.50/05131a

2. Press the DISPLAY button, while the character of " Ver.0.50/05131a " is displayed.

E1A48K015FF 23o

To exit

Press STANDBY/ON button.

Content of display

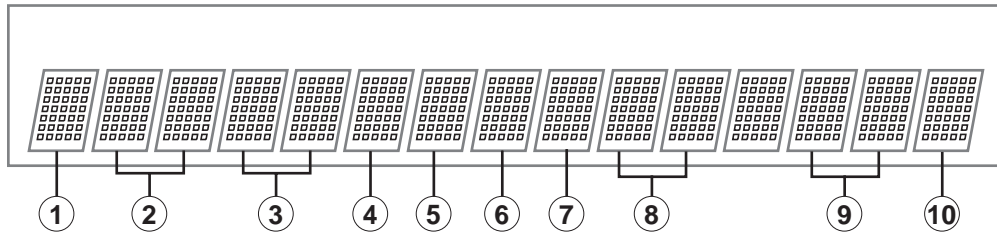

----- DIR -----

- ① UNLOCK
E = UNLOCK
= LOCK
- ② Digital Selector
D = DIGITAL
A = ANALOG
1 = COAX1
2 = OOAX2
3 = OPT1
4 = OPT2
5 = OPT3
7 = FRONT
- ③ Sampling Frequency
96 = 96kHz
48 = 48kHz
44 = 44kHz
32 = 32kHz
-- = Not detect
- ④ Pre Emphasis
K = OFF
e = ON
- ⑤ DIR Status
0 = ANALOG
1 = PCM
2 = NOT_PCM
3 = DATA
4 = DTSCD
5 = MCH
6 = NOT DECIED

----- MEMORY/DOWNLOAD -----

- ⑥ AUTOBOOT DSP AB CODE
0 = FLASH
1 = ab_ac3_pl2
2 = ab_dts_pl2
3 = ab_neo6
4 = sgen_ab
5 = ab_pl2fs
6 = ab_dts_6dol
7 = ab_dts9624
8 = aac_pl2
- ⑦ AUTOBOOT DSP C CODE
0 = ac_dts9624
1 = c_neo6
2 = c_oos_no_sd
3 = c_oos
4 = c_oob
5 = c_pl2
6 = c_pl2xthx
7 = c_thx
8 = c_spsetup
9 = version

----- DSP -----

- ⑧ DSP Status
00 = Power off
01 = Power on wait
10 = DSP reset
11 = DSP reset wait
12 = DSP AB boot ready
13 = DSP AB boot start
14 = DSP AB boot
15 = DSP C boot ready
16 = DSP C boot start
17 = DSP C boot
18 = DSP soft reset
20 = DSP C app start
21 = DSP C HW Config set
22 - 2A = DSP C SW Config set
3F = DSP C kick start
40 = DSP AB App start
41 = DSP AB HW Config set
42 - 4B = DSP AB SW Config set
AF = DSP ab kick start
- ⑨ DSP Detect Format
00 = Null
01 = Dolby Digital
03 = Pause
04 = MPEG1 L1
05 = MPEG1 L23/ MPEG2 w/o
06 = MPEG2 w/e
07 = MPEG2 AAC
08 = MPEG2 L1
09 = MPEG2 L2/3
0B = DTS1
0C = DTS2
0D = DTS3
1B = MPEG2 AAC1
1C = MPEG2 AAC2
20 = Silent
22 = DTS CD
23 = PCM
- ⑩ DSP Decode
o = Decode OK
x = Decode NG
-- = Analog in

EXPLODED VIEWS-1

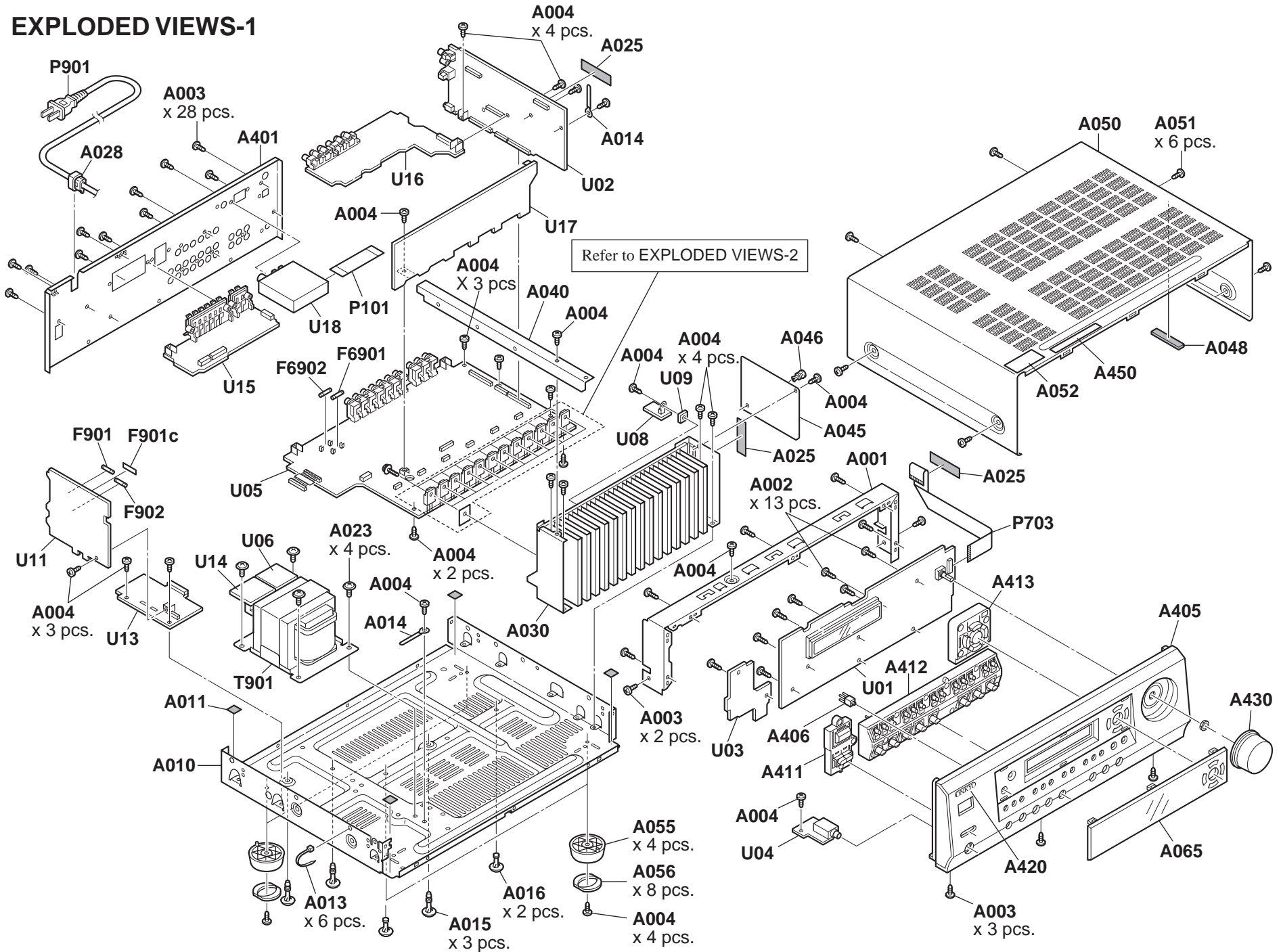

EXPLODED VIEWS-2

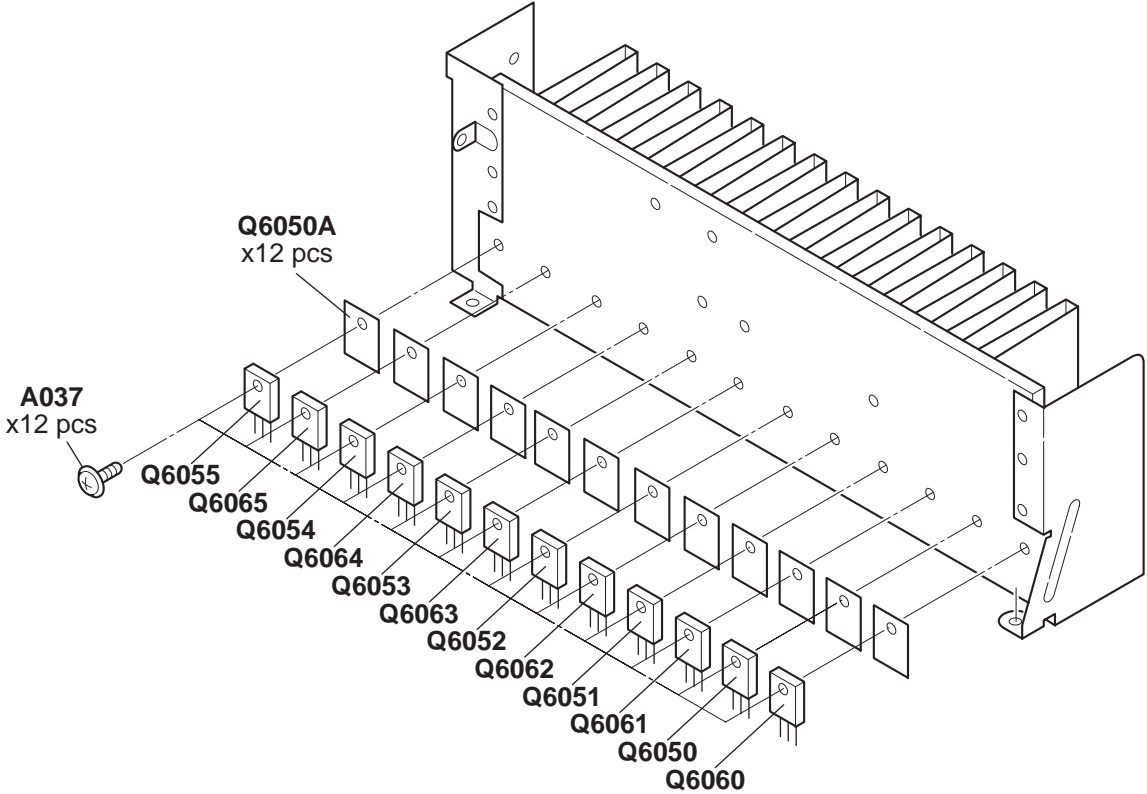

A

B

C

D

BLOCK DIAGRAM

1

2

3

4

5

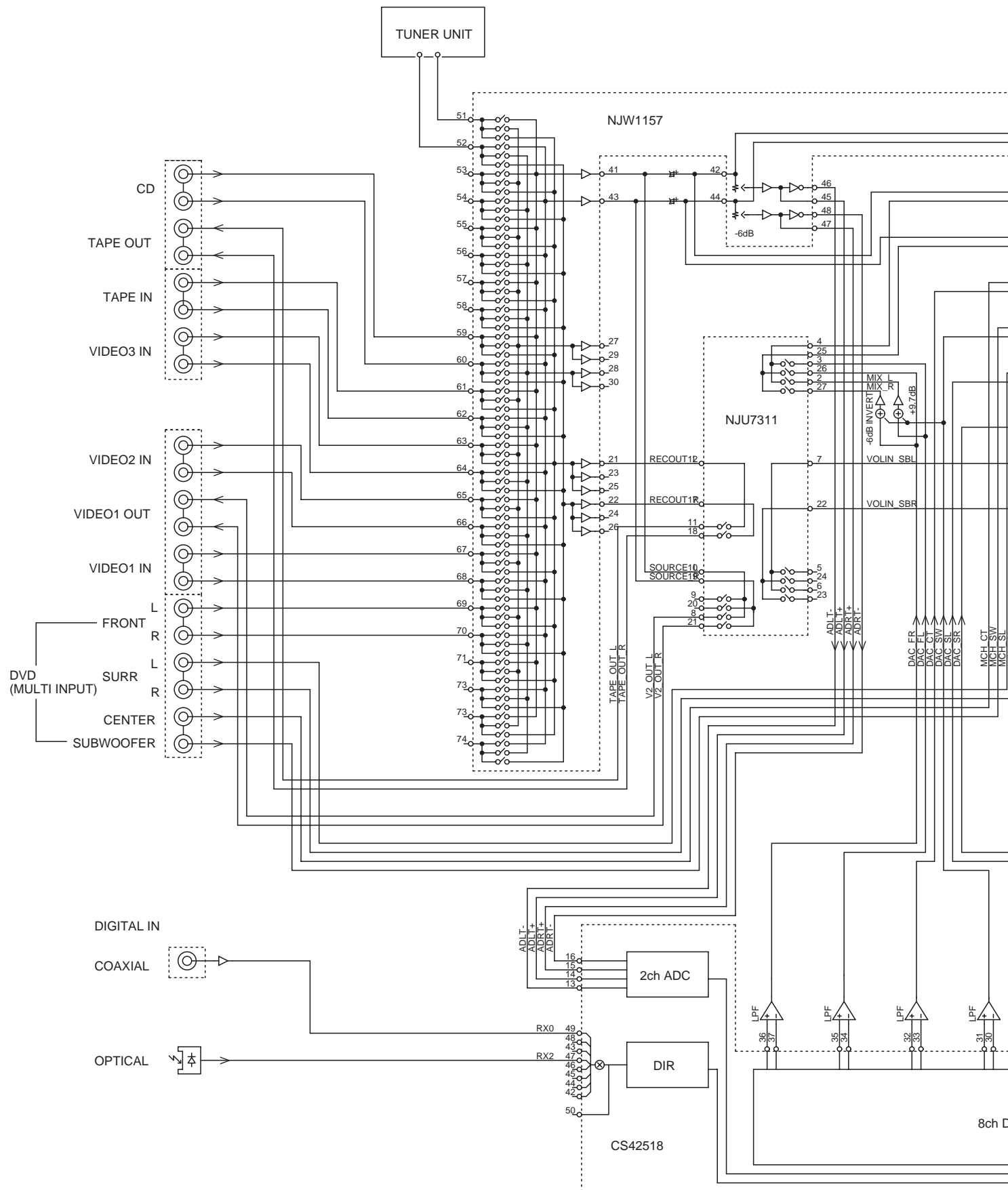

E F G H

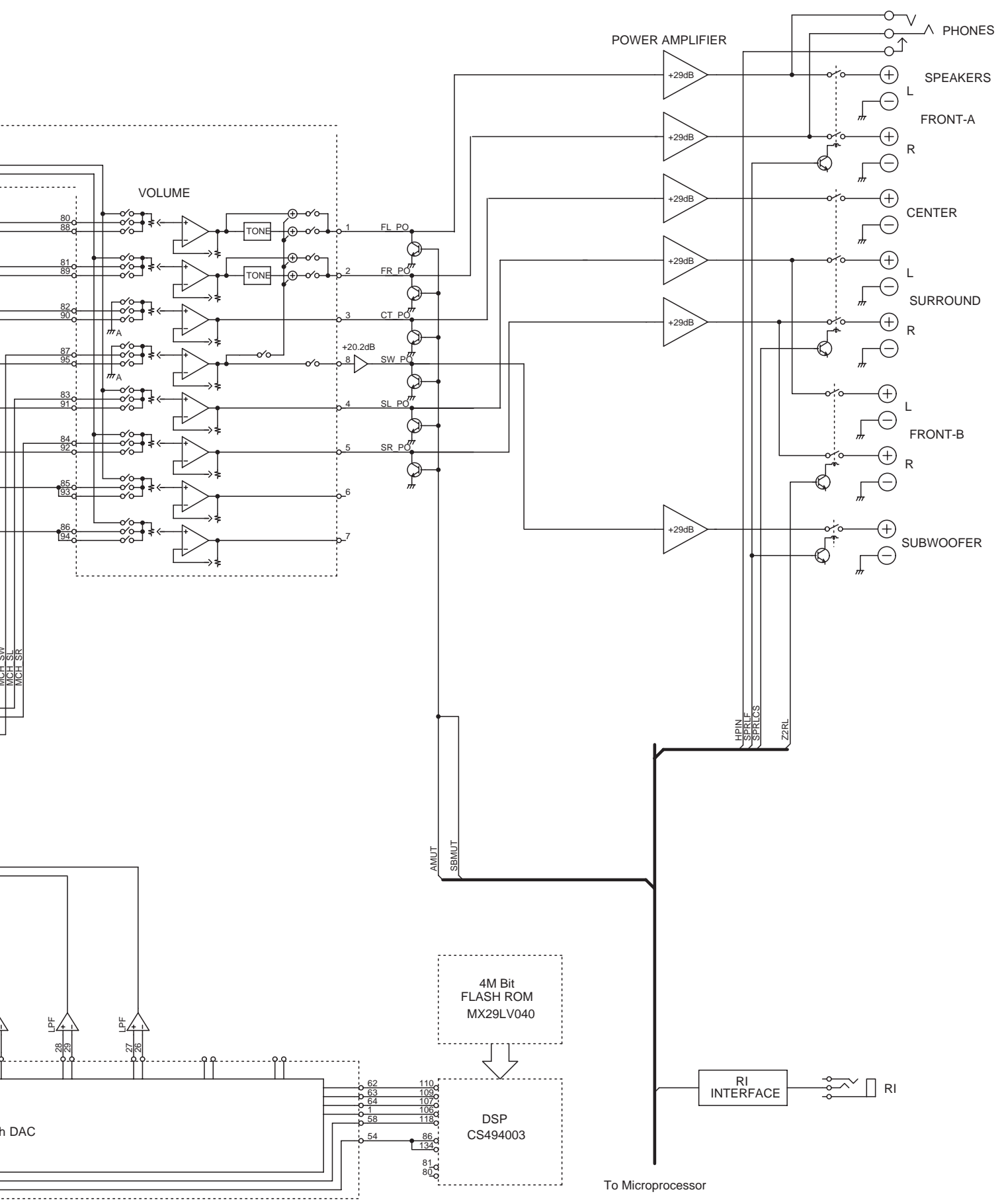

SCHEMATIC DIAGRAMS-1

AUDIO INPUT SECTION

TO NADG-8514

NAAF-8523 (1/2)

U05
AMPLIFIER PC BOARD

1

2

3

4

5

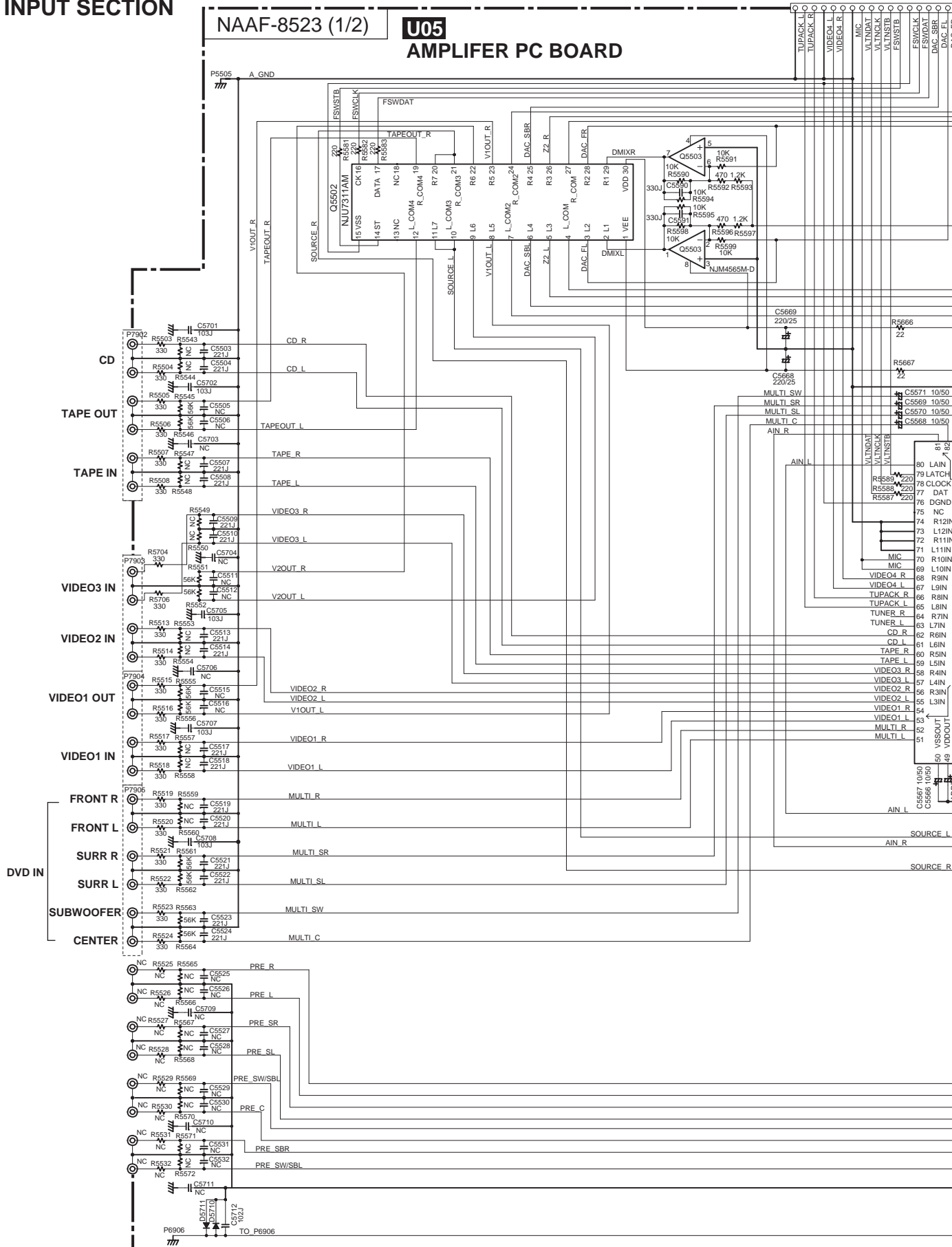

TO NADG-8514

TO NADG-8514

TO NADG-8514

TO NAAF-8523(2/2)

TO NAPS-8546

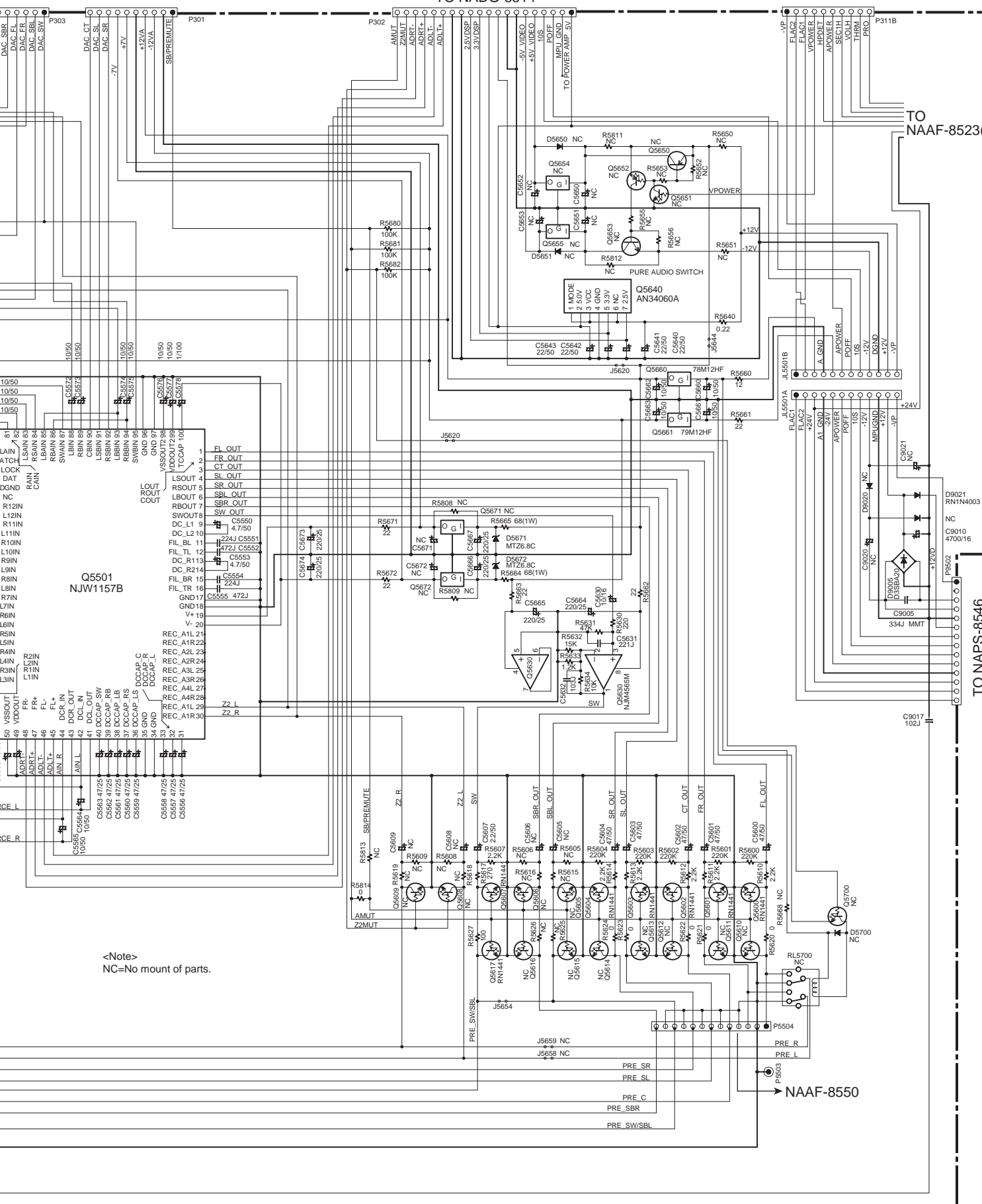

<Note>
NC=No mount of parts.

NAAF-8550

SCHEMATIC DIAGRAMS-1

AUDIO INPUT SECTION

NAAF-8523 (1/2)

U05
AMPLIFIER PC BOARD

TO NADG-8514

TO NADG-8514

TO NADG-8514

TO NADG-8514

TO NAAF-8523(2/2)

TO NAPS-8546

1

2

3

4

5

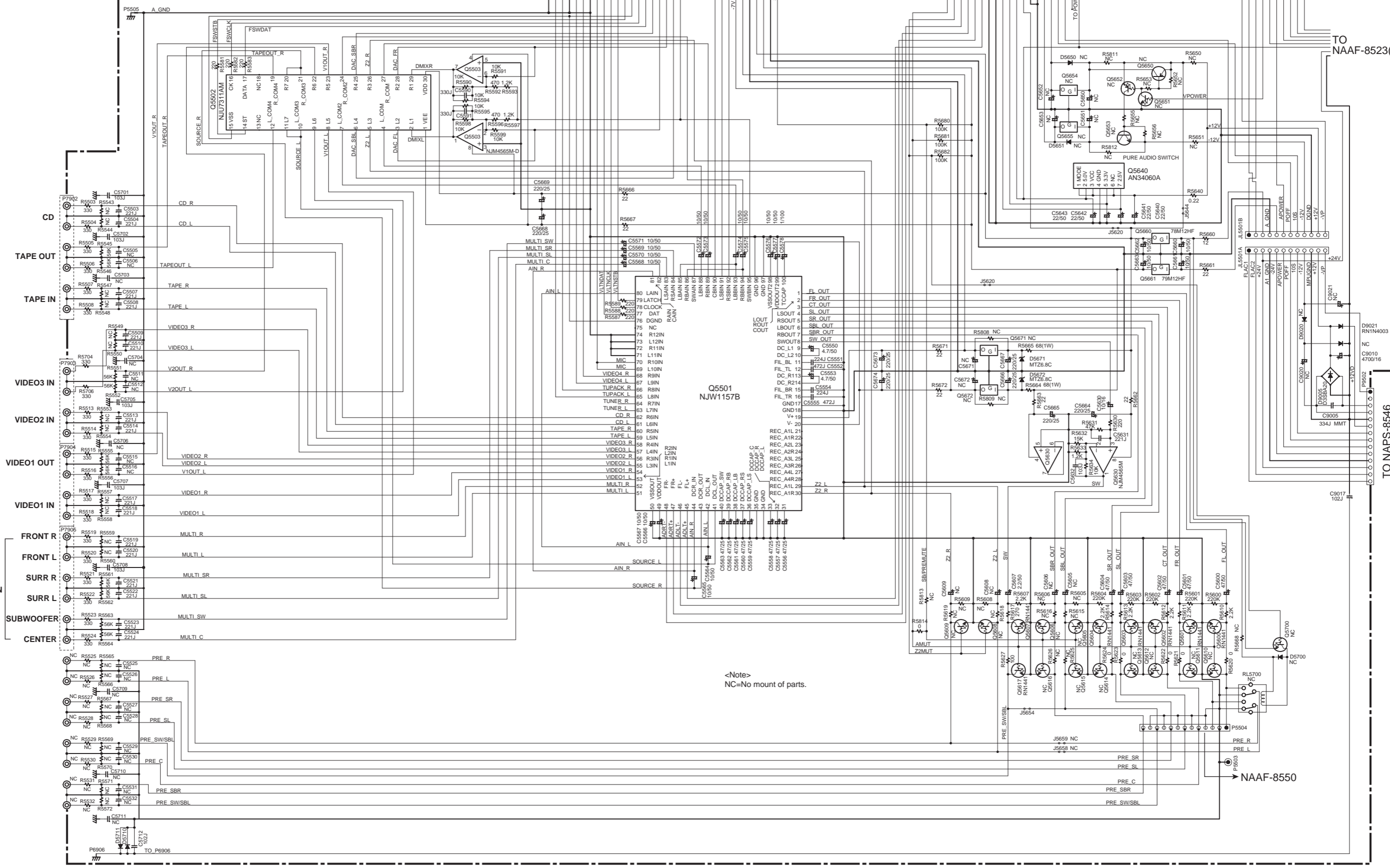

<Note>
NC=No mount of parts.

NAAF-8550

SCHEMATIC DIAGRAMS-2

DSP SECTION

A B C D

TO NADIS-8513 TO TUNER UNIT NC TO NAVD-8513

1

2

3

4

5

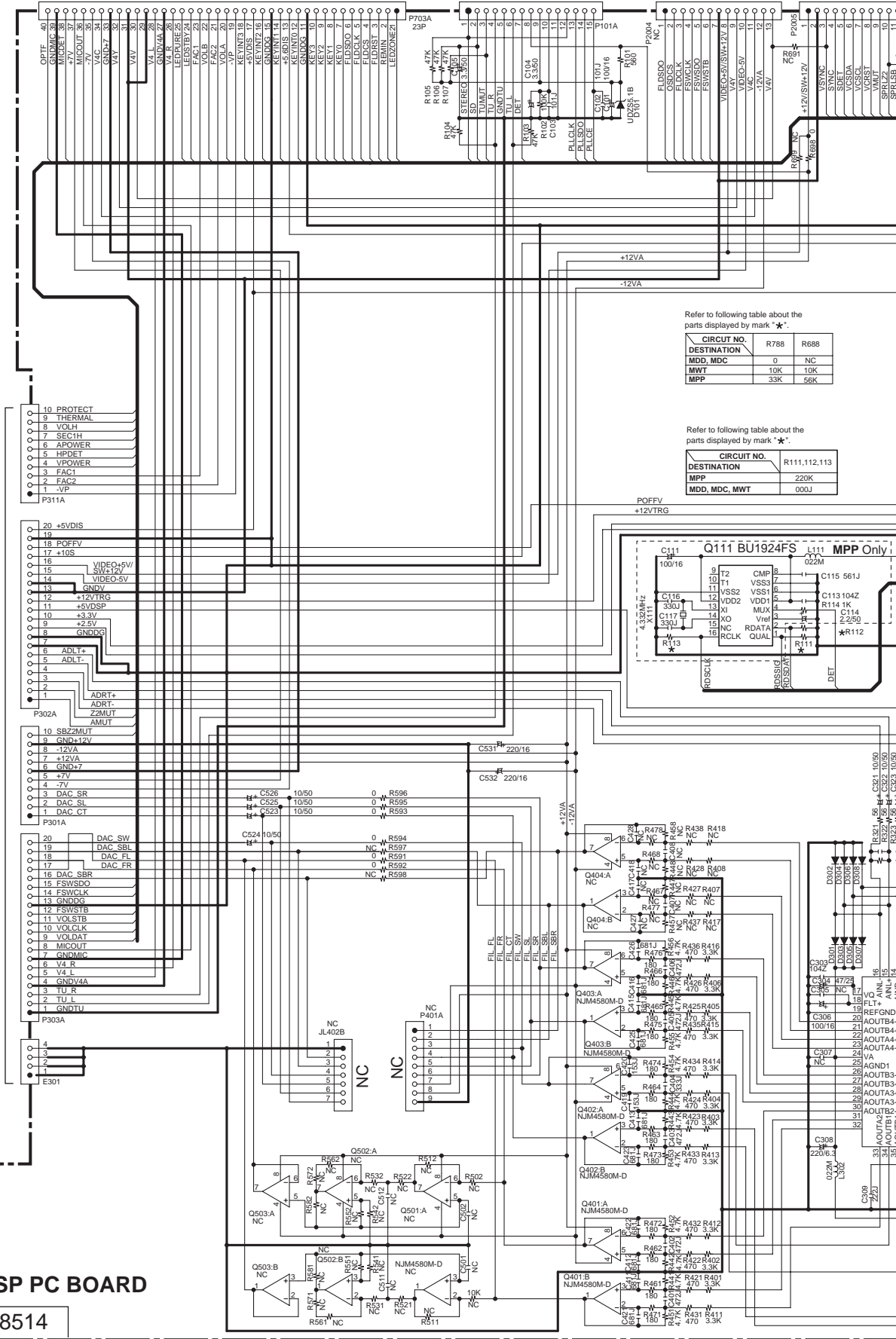

Refer to following table about the parts displayed by mark '*'.*

CIRCUIT NO.	R788	R688
MDD, MDC	0	NC
MWT	10K	10K
MPP	33K	56K

Refer to following table about the parts displayed by mark '*'.*

CIRCUIT NO.	R111,112,113
MPP	220K
MDD, MDC, MWT	000J

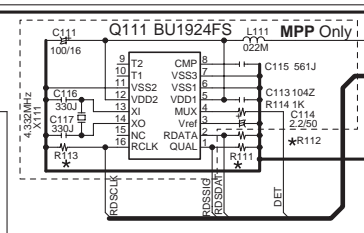

TO NAAF-8523

U02 DSP PC BOARD
NADG-8514

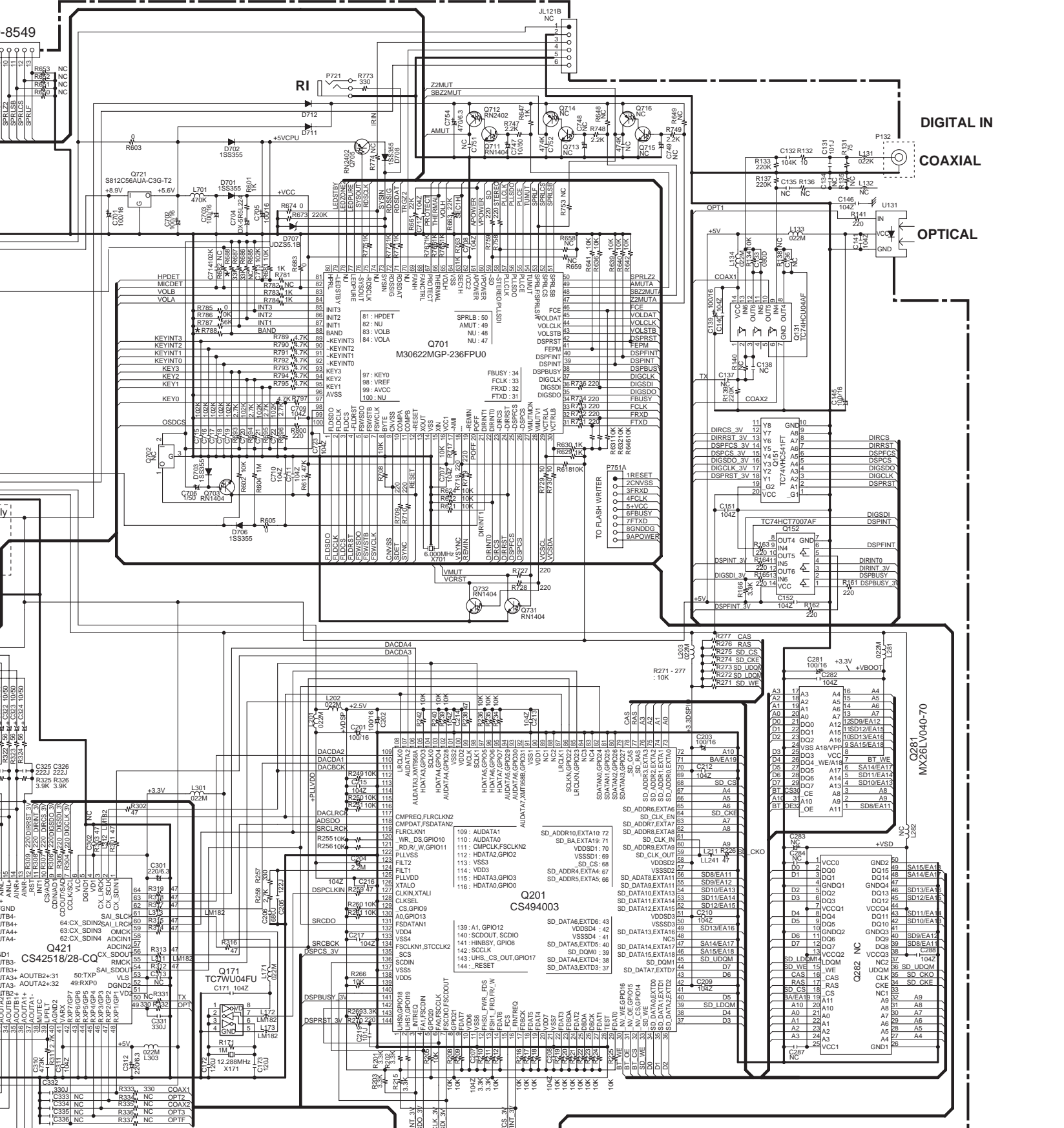

DIGITAL IN

COAXIAL

OPTICAL

Q281 MX26L040-70

Q282 NC

Q283 NC

Q284 NC

SCHEMATIC DIAGRAMS-2
DSP SECTION

1

2

3

4

5

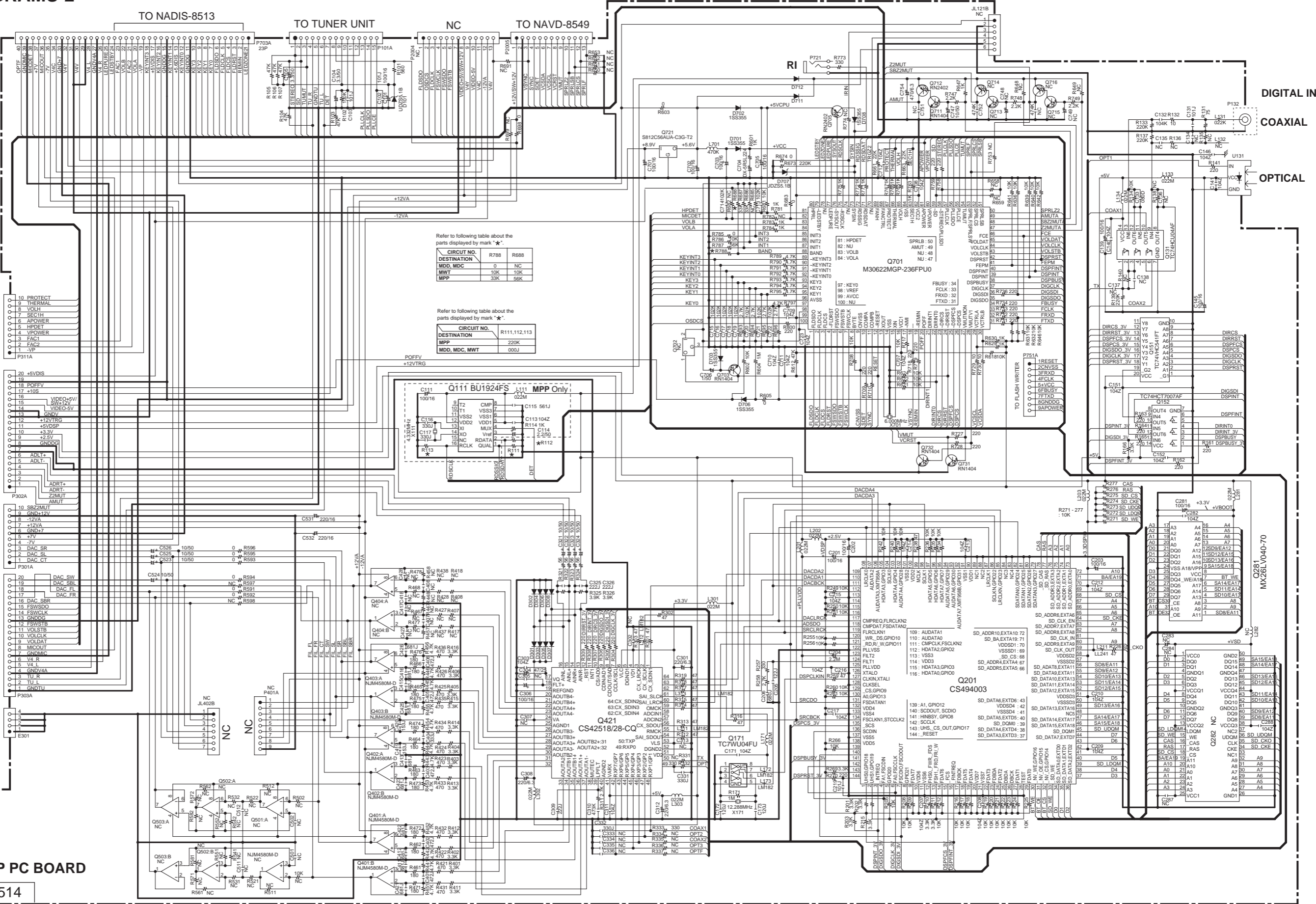

Refer to following table about the parts displayed by mark "★":

CIRCUIT NO.	DESTINATION	R788	R688
MDD, MDC	0	NC	
MWT	10K	10K	
MPP	33K	56K	

Refer to following table about the parts displayed by mark "★":

CIRCUIT NO.	DESTINATION	R111,112,113
MPP	220K	
MDD, MDC, MWT	000J	

TO NAAF-8523

U02 DSP PC BOARD
NADG-8514

DIGITAL IN
COAXIAL
OPTICAL

Q281
MX26LV040-70

A

B

C

D

SCHEMATIC DIAGRAMS-3

DRIVER AMPLIFIER SECTION

1

Refer to following table about the parts displayed by mark " * ".

Transistors

CIRCUIT NO.	DESCRIPTION
Q5000 - 5002 Q5010 - 5012	2SC2240-BL
Q5003 - 5005 Q5013 - 5015	2SC2240-BL, KTC3200-BL
Q5030 - 5035	2SA949-Y
Q5040 - 5045	2SC2229-Y
Q5050 - 5055	2SC1815-GR, BL

2

NOTE

- THE COMPONENTS IDENTIFIED BY MARK Δ ARE CRITICAL FOR SAFETY REPLACE ONLY WITH PART NUMBER SPECIFIED.
- VOLTAGE (MEASURED WITH VOLTMETER) \leftarrow IS DC VOLTAGE.(NO INPUT SIGNAL).
- ALL PNP TRANSISTORS ARE EQUIVALENT TO 2SA1015-GR UNLESS OTHERWISE NOTED.
- ALL NPN TRANSISTORS ARE EQUIVALENT TO 2SC1815-GR UNLESS OTHERWISE NOTED.
- ALL DIODES ARE EQUIVALENT TO 1SS133 UNLESS OTHERWISE NOTED.
- ELECTROLYTIC CAPACITORS ($\text{---} \parallel \text{---}$) ARE IN $\mu\text{F/WV}$.
- ALL CAPACITORS ARE IN pF/50WV UNLESS OTHERWISE NOTED.
EX) 030-3pF 330-33pF 331-330pF 333-0.033 μF
- ALL RESISTORS ARE IN OHMS 1/4WATTS UNLESS OTHERWISE NOTED.
- THE THICK LINES ON PC BOARD ARE THE PRINTING SIDE OF THE PARTS.
EX) $\square \square \square$ PRINTING SIDE
- CIRCUIT IS SUBJECT TO CHANGE FOR IMPROVEMENT.

<Note>
NC=No mount of parts.

3

4

5

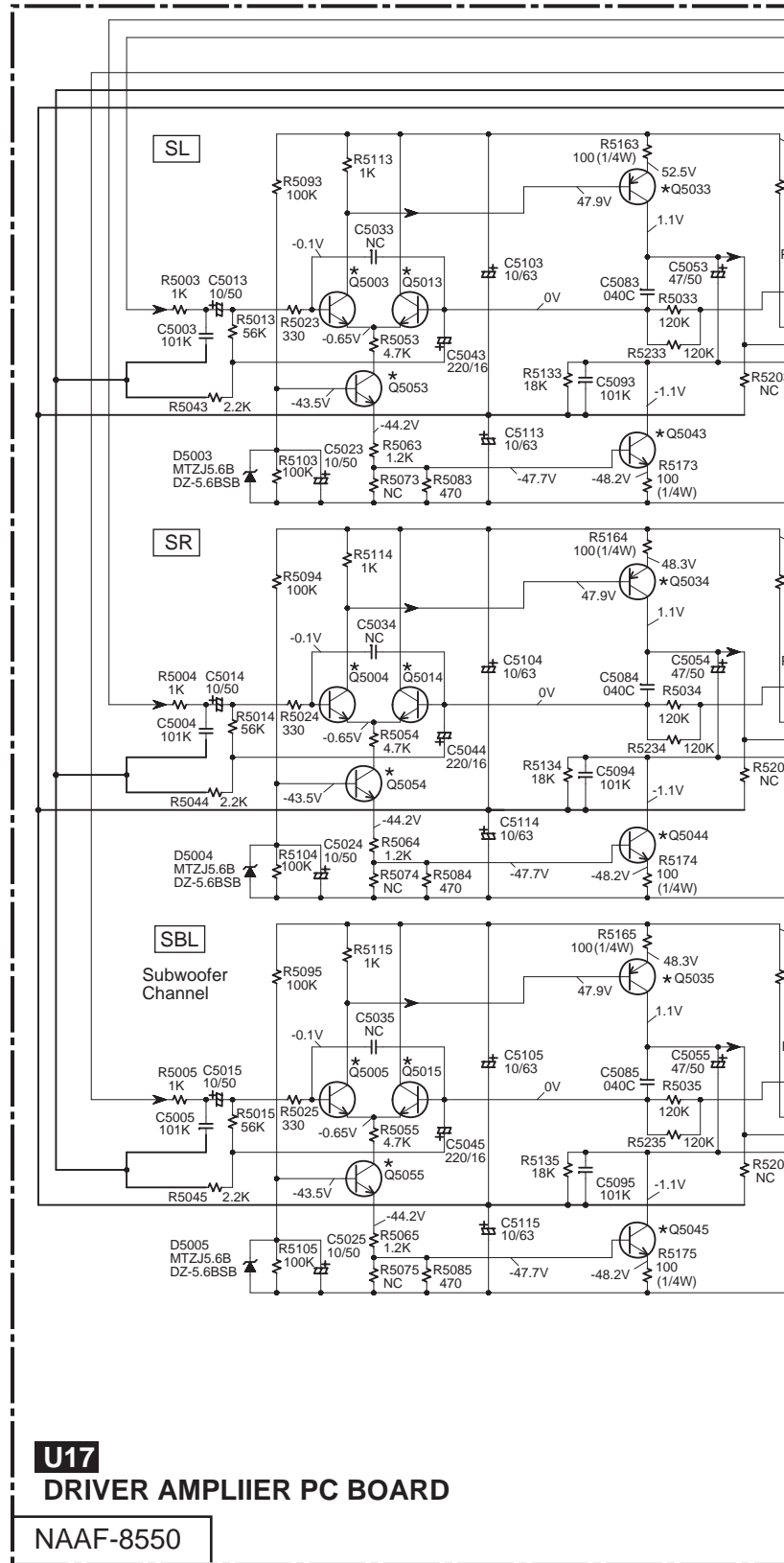

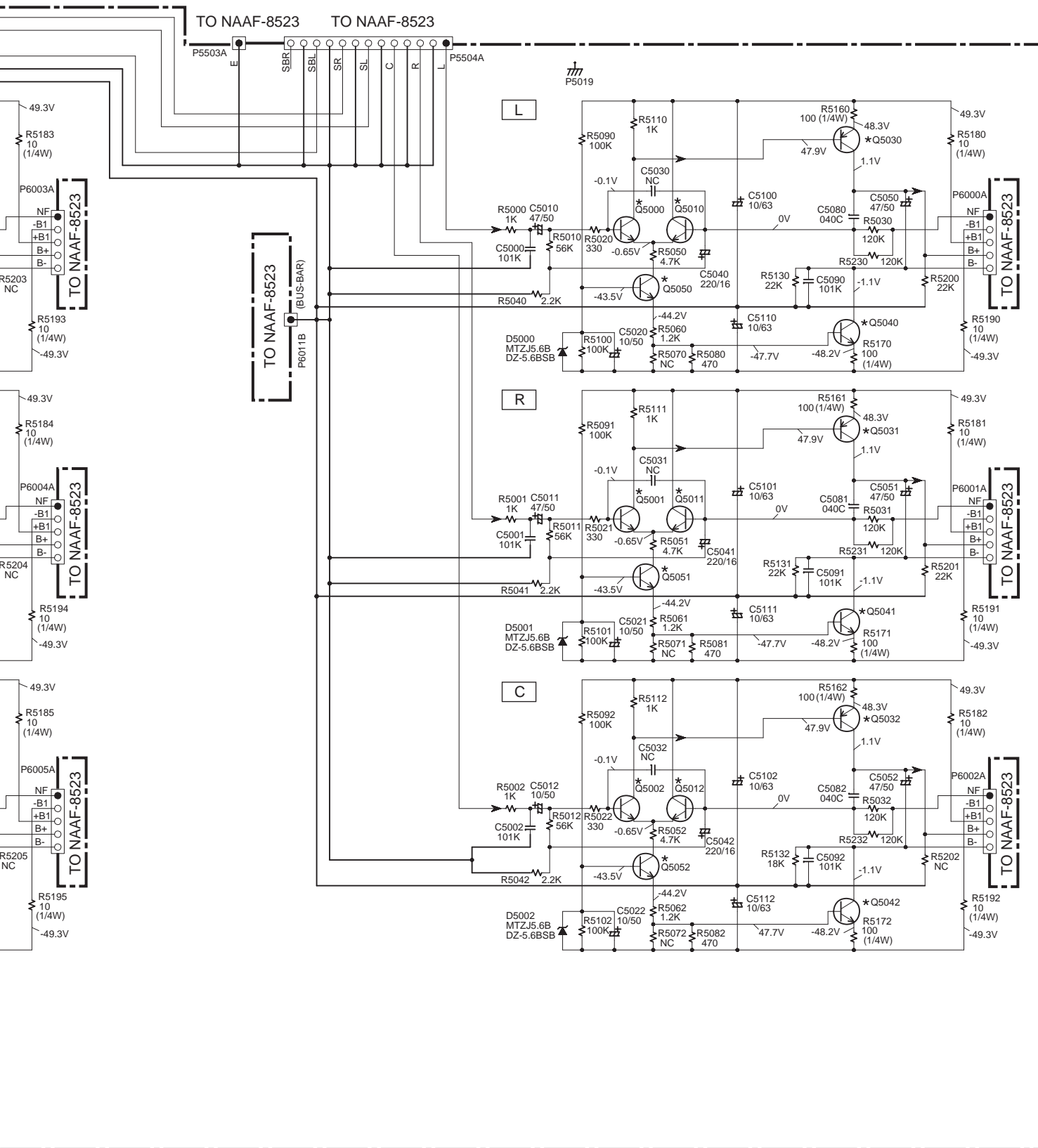

SCHEMATIC DIAGRAMS-3
DRIVER AMPLIFIER SECTION

Refer to following table about the parts displayed by mark " * " .

Transistors

CIRCUIT NO.	DESCRIPTION
Q5000 - 5002 Q5010 - 5012	2SC2240-BL
Q5003 - 5005 Q5013 - 5015	2SC2240-BL, KTC3200-BL
Q5030 - 5035	2SA949-Y
Q5040 - 5045	2SC2229-Y
Q5050 - 5055	2SC1815-GR, BL

NOTE

- THE COMPONENTS IDENTIFIED BY MARK Δ ARE CRITICAL FOR SAFETY REPLACE ONLY WITH PART NUMBER SPECIFIED.
- VOLTAGE (MEASURED WITH VOLTMETER) \leftarrow IS DC VOLTAGE.(NO INPUT SIGNAL).
- ALL PNP TRANSISTORS ARE EQUIVALENT TO 2SA1015-GR UNLESS OTHERWISE NOTED.
- ALL NPN TRANSISTORS ARE EQUIVALENT TO 2SC1815-GR UNLESS OTHERWISE NOTED.
- ALL DIODES ARE EQUIVALENT TO 1SS133 UNLESS OTHERWISE NOTED.
- ELECTROLYTIC CAPACITORS (---) ARE IN $\mu\text{F/WV}$.
- ALL CAPACITORS ARE IN pF/50V UNLESS OTHERWISE NOTED.
EX) 030- 3pF 330- 33pF 331- 330pF 333- 0.033 μF
- ALL RESISTORS ARE IN OHMS 1/4WATTS UNLESS OTHERWISE NOTED.
- THE THICK LINES ON PC BOARD ARE THE PRINTING SIDE OF THE PARTS.
EX) \square PRINTING SIDE
- CIRCUIT IS SUBJECT TO CHANGE FOR IMPROVEMENT.

<Note>

NC=No mount of parts.

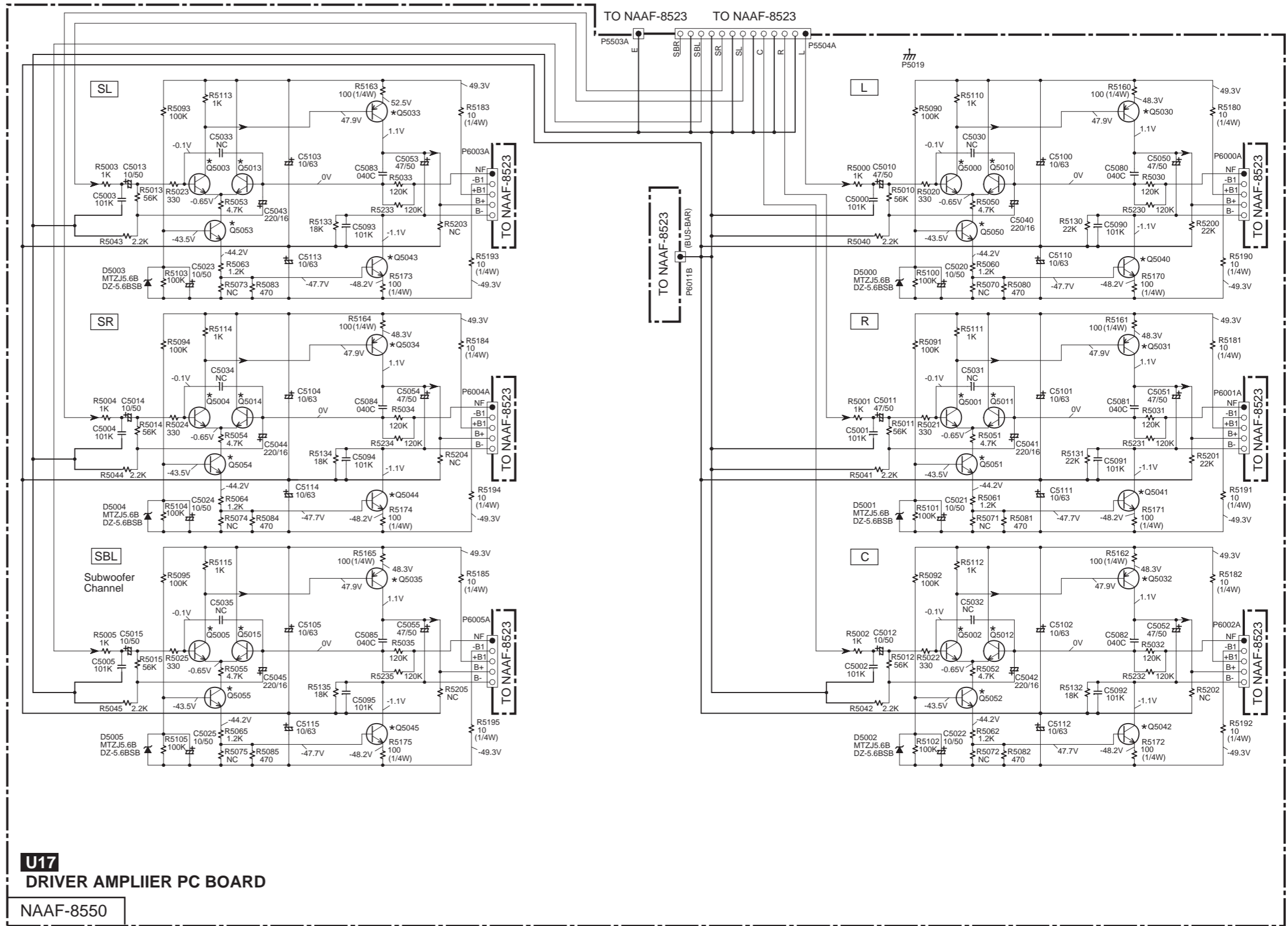

A

B

C

D

SCHEMATIC DIAGRAMS-4 POWER AMPLIFIER SECTION

1

Refer to following table about the parts displayed by mark " * " .

Transistors

CIRCUIT NO.	DESCRIPTION
Q6010 - 6015	2SC1740S-S
Q6020 - 6025	2SC1740S-S
Q6030 - 6032	2SC5171, 2SC5993-Q, P
Q6033 - 6035	2SC5171, 2SC5511-E
Q6040 - 6042	2SA1930, 2SA2140-Q, P
Q6043 - 6045	2SA1930, 2SA2005-E
Q6050 - 6052	2SC5198-O, R, MN130S-Y, P, O
Q6053 - 6055	KTC5242A-O, R, MN130S-Y, P, O
Q6060 - 6062	2SA1941-O, R, MP130S-Y, P, O
Q6063 - 6065	KTA1962A-O, R, MP130S-Y, P, O
Q6070 - 6075	2SC2240-GR, BL
Q6701, 6702	2SC2240-GR, BL, KTC3200-GR, BL
Q6703	KTA1268-BL, GR, 2SA992-E, F 2SA1123-R
Q6901	KTC3199-GR, 2SC2458-GR, 2SC1740S-R, S

2

NOTE

- THE COMPONENTS IDENTIFIED BY MARK \triangle ARE CRITICAL FOR SAFETY REPLACE ONLY WITH PART NUMBER SPECIFIED.
- VOLTAGE (MEASURED WITH VOLTMETER) \square IS DC VOLTAGE.(NO INPUT SIGNAL).
- ALL PNP TRANSISTORS ARE EQUIVALENT TO 2SA1015-GR UNLESS OTHERWISE NOTED.
- ALL NPN TRANSISTORS ARE EQUIVALENT TO 2SC1815-GR UNLESS OTHERWISE NOTED.
- ALL DIODES ARE EQUIVALENT TO 1SS133 UNLESS OTHERWISE NOTED.
- ELECTROLYTIC CAPACITORS (\square) ARE IN μ F/WV.
- ALL CAPACITORS ARE IN pF/50V UNLESS OTHERWISE NOTED.
EX) 030- 3pF 330- 33pF 331- 330pF 333- 0.033 μ F
- ALL RESISTORS ARE IN OHMS 1/4WATTS UNLESS OTHERWISE NOTED.
- THE THICK LINES ON PC BOARD ARE THE PRINTING SIDE OF THE PARTS.
EX) \square PRINTING SIDE
- CIRCUIT IS SUBJECT TO CHANGE FOR IMPROVEMENT.

<Note>
NC=No mount of parts.

4

5

NAAF-8523 (2/2)

U05

AMPLIFIER PC BOARD

SL

TO NAAF-8550

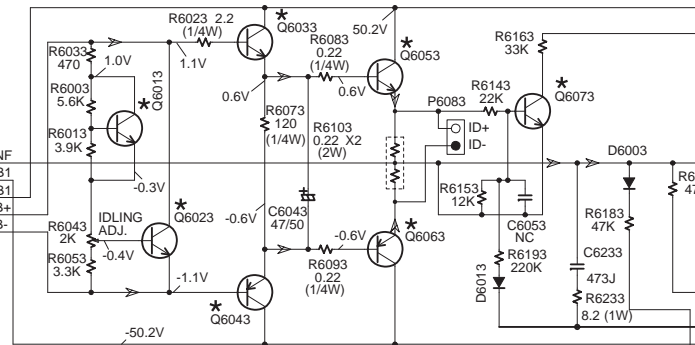

SR

TO NAAF-8550

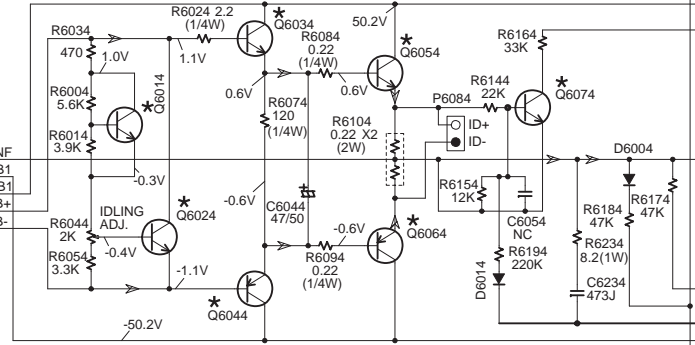

SBL

Subwoofer Channel
TO NAAF-8550

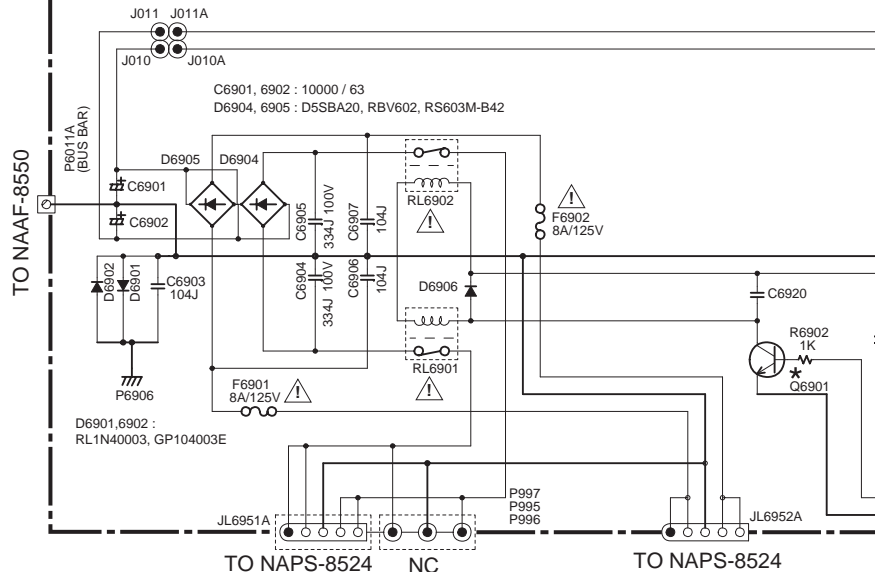
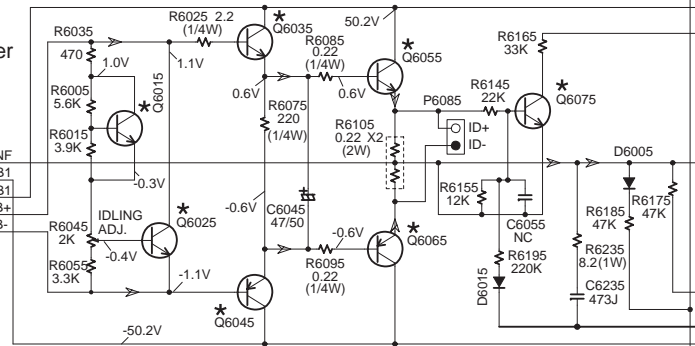

E

F

G

H

L

R

C

U08

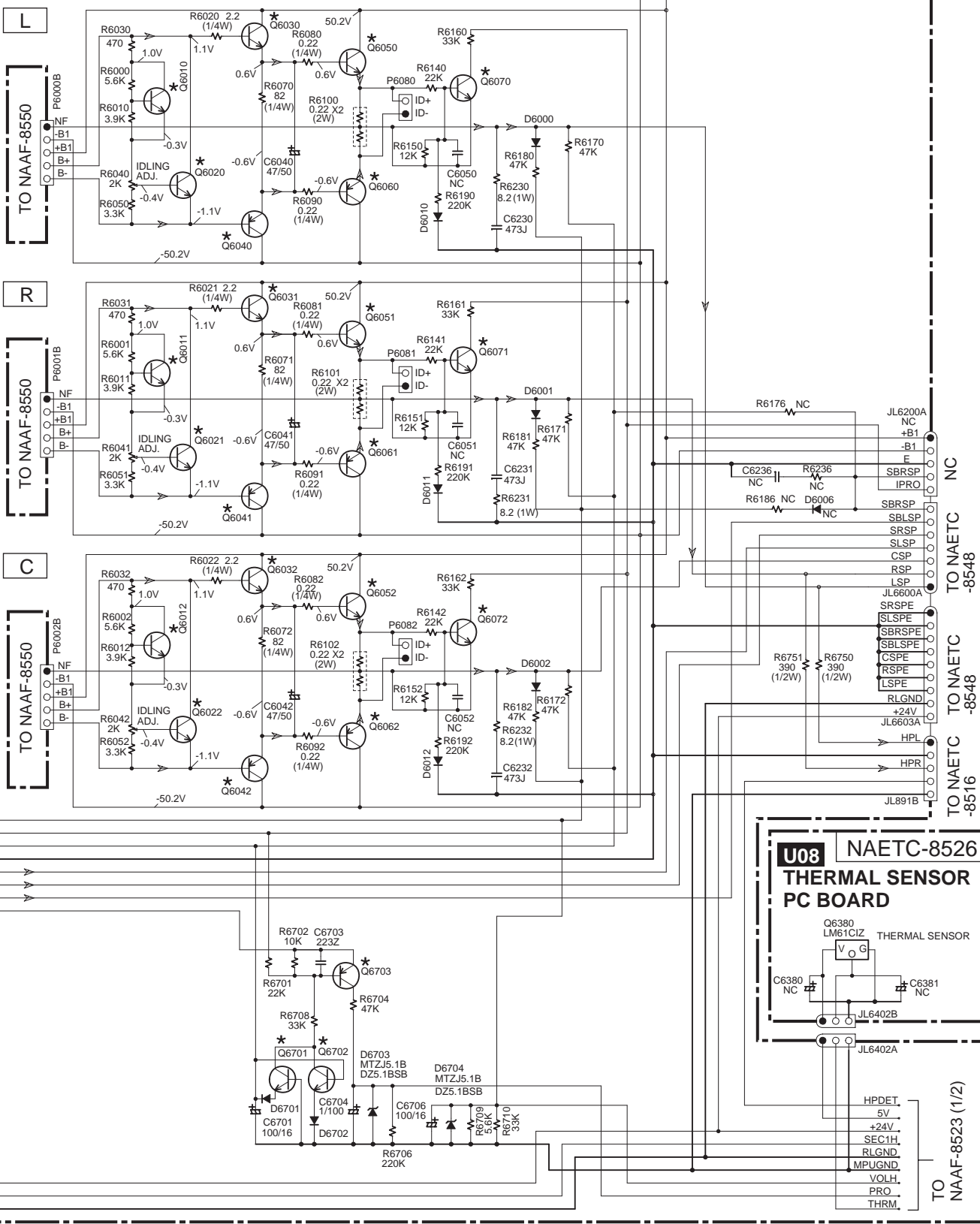

TO NAAF-8550

TO NAAF-8550

TO NAAF-8550

NAETC-8526
THERMAL SENSOR
PC BOARD

TO NAETC -8548

TO NAETC -8548

TO NAETC -8516

TO NAAF-8523 (1/2)

SCHEMATIC DIAGRAMS-4 POWER AMPLIFIER SECTION

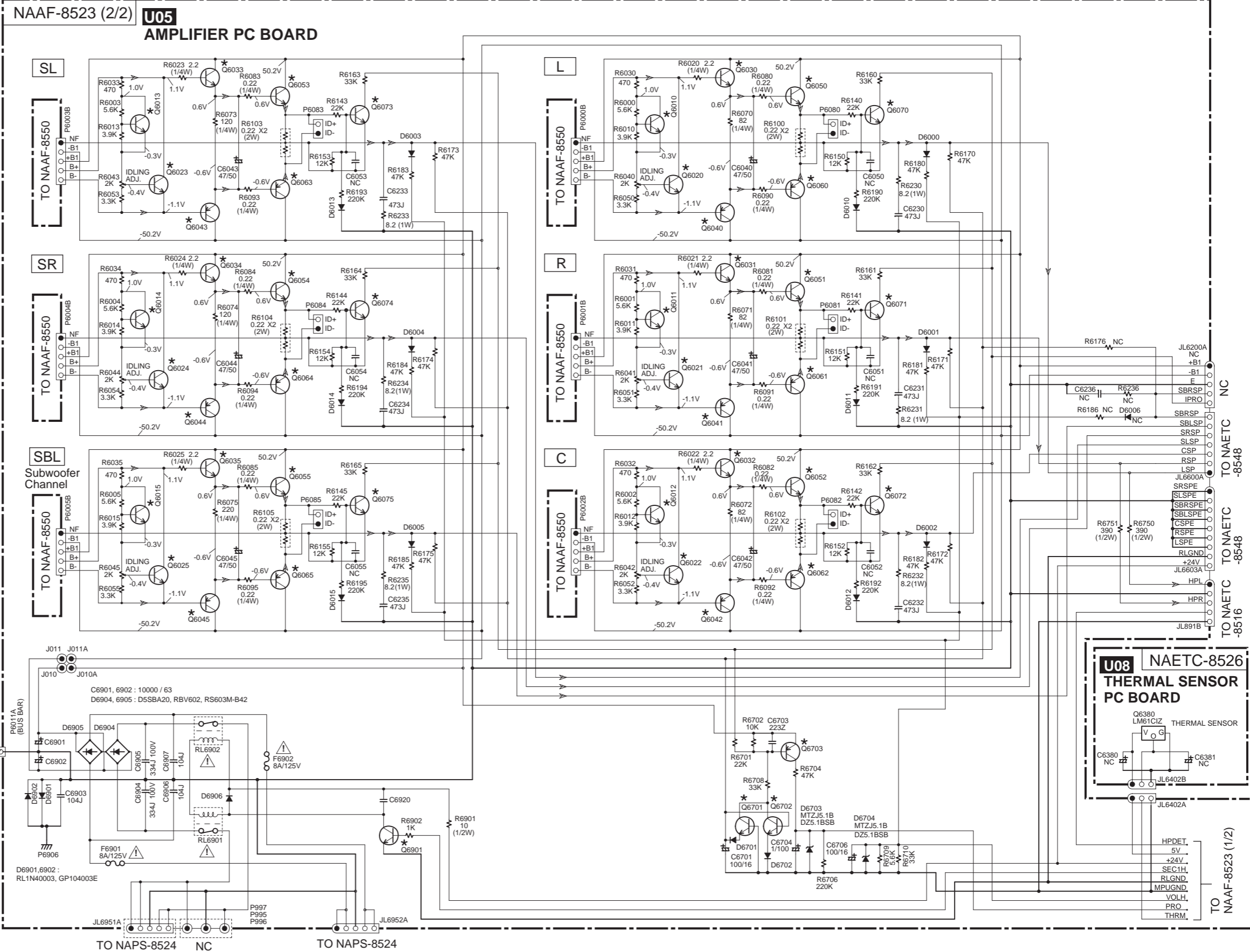

Refer to following table about the parts displayed by mark " * ".

Transistors

CIRCUIT NO.	DESCRIPTION
Q6010 - 6015	2SC1740S-S
Q6020 - 6025	2SC1740S-S
Q6030 - 6032	2SC5171, 2SC5993-Q, P
Q6033 - 6035	2SC5171, 2SC5511-E
Q6040 - 6042	2SA1930, 2SA2140-Q, P
Q6043 - 6045	2SA1930, 2SA2005-E
Q6050 - 6052	2SC5198-O, R, MN130S-Y, P, O
Q6053 - 6055	KTC5242A-O, R, MN130S-Y, P, O
Q6060 - 6062	2SA1941-O, R, MP130S-Y, P, O
Q6063 - 6065	KTA1962A-O, R, MP130S-Y, P, O
Q6070 - 6075	2SC2240-GR, BL
Q6701, 6702	2SC2240-GR, BL, KTC3200-GR, BL
Q6703	KTA1268-BL, GR, 2SA992-E, F 2SA1123-R
Q6901	KTC3199-GR, 2SC2458-GR, 2SC1740S-R, S

NOTE

- THE COMPONENTS IDENTIFIED BY MARK \triangle ARE CRITICAL FOR SAFETY REPLACE ONLY WITH PART NUMBER SPECIFIED.
- VOLTAGE (MEASURED WITH VOLTMETER) \leftarrow IS DC VOLTAGE.(NO INPUT SIGNAL).
- ALL PNP TRANSISTORS ARE EQUIVALENT TO 2SA1015-GR UNLESS OTHERWISE NOTED.
- ALL NPN TRANSISTORS ARE EQUIVALENT TO 2SC1815-GR UNLESS OTHERWISE NOTED.
- ALL DIODES ARE EQUIVALENT TO 1SS133 UNLESS OTHERWISE NOTED.
- ELECTROLYTIC CAPACITORS (---) ARE IN $\mu\text{F/WV}$.
- ALL CAPACITORS ARE IN $\text{pF}/50\text{VWV}$ UNLESS OTHERWISE NOTED.
EX) 030-3pF 330-33pF 331-330pF 333-0.033 μF
- ALL RESISTORS ARE IN OHMS 1/4WATTS UNLESS OTHERWISE NOTED.
- THE THICK LINES ON PC BOARD ARE THE PRINTING SIDE OF THE PARTS.
EX) PRINTING SIDE
- CIRCUIT IS SUBJECT TO CHANGE FOR IMPROVEMENT.

<Note>
NC=No mount of parts.

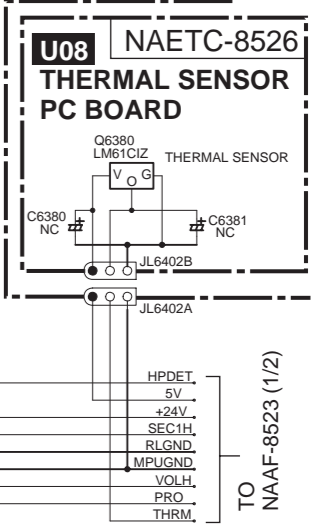

A

B

C

D

SCHEMATIC DIAGRAMS-5

SPEAKER TERMINAL SECTION

1

NOTE

- THE COMPONENTS IDENTIFIED BY MARK Δ ARE CRITICAL FOR SAFETY. REPLACE ONLY WITH PART NUMBER SPECIFIED.
- VOLTAGE (MEASURED WITH VOLTMETER) \leftarrow IS DC VOLTAGE.(NO INPUT SIGNAL).
- ALL PNP TRANSISTORS ARE EQUIVALENT TO 2SA1015-GR UNLESS OTHERWISE NOTED.
- ALL NPN TRANSISTORS ARE EQUIVALENT TO 2SC1815-GR UNLESS OTHERWISE NOTED.
- ALL DIODES ARE EQUIVALENT TO 1SS133 UNLESS OTHERWISE NOTED.
- ELECTROLYTIC CAPACITORS (---) ARE IN $\mu\text{F/WV}$.
- ALL CAPACITORS ARE IN pF/50WV UNLESS OTHERWISE NOTED.
EX) 030- 3pF 330- 33pF 331- 330pF 333- 0.033 μF
- ALL RESISTORS ARE IN OHMS 1/4WATTS UNLESS OTHERWISE NOTED.
- THE THICK LINES ON PC BOARD ARE THE PRINTING SIDE OF THE PARTS.
EX) \square PRINTING SIDE
- CIRCUIT IS SUBJECT TO CHANGE FOR IMPROVEMENT.

<Note>

NC=No mount of parts.

Refer to following table about the parts displayed by mark "*".

DESTINATION	C6640 - 6648	C6650 - 6658
MDD, MDC	NO	NO
MPP, MWT	YES	YES

2

3

4

5

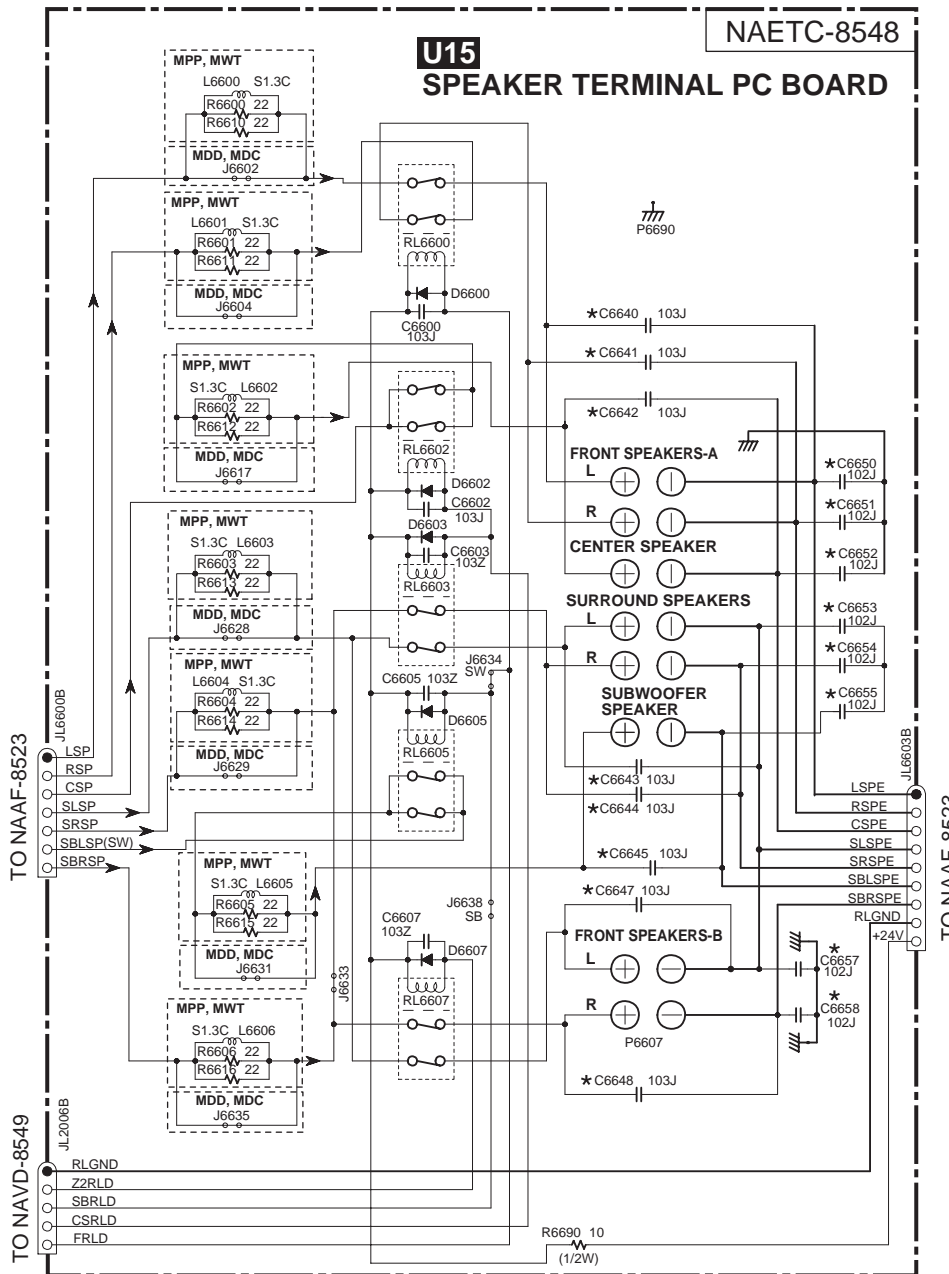

A





B

C

D

SCHEMATIC DIAGRAMS-6
POWER SUPPLY SECTION

NOTE

- THE COMPONENTS IDENTIFIED BY MARK  ARE CRITICAL FOR SAFETY. REPLACE ONLY WITH PART NUMBER SPECIFIED.
- VOLTAGE (MEASURED WITH VOLTMETER)  IS DC VOLTAGE (NO INPUT SIGNAL).
- ALL PNP TRANSISTORS ARE EQUIVALENT TO 2SA1015-GR UNLESS OTHERWISE NOTED.
- ALL NPN TRANSISTORS ARE EQUIVALENT TO 2SC1815-GR UNLESS OTHERWISE NOTED.
- ALL DIODES ARE EQUIVALENT TO 1SS133 UNLESS OTHERWISE NOTED.
- ELECTROLYTIC CAPACITORS () ARE IN uF/WV.
- ALL CAPACITORS ARE IN pF/50V UNLESS OTHERWISE NOTED.
EX) 030- 3pF 330- 33pF 331- 330pF 333- 0.033uF
- ALL RESISTORS ARE IN OHMS 1/4WATTS UNLESS OTHERWISE NOTED.
- THE THICK LINES ON PC BOARD ARE THE PRINTING SIDE OF THE PARTS.
EX)  PRINTING SIDE
- CIRCUIT IS SUBJECT TO CHANGE FOR IMPROVEMENT.

<Note>

NC=No mount of parts.

Refer to following table about the parts displayed by mark "★".

CIRCUIT NO.	T902
DESTINATION	
MDD, MDC	NPT-1520JQ
MWT	NPT-1519JQ
MPP	NPT-1519GQ

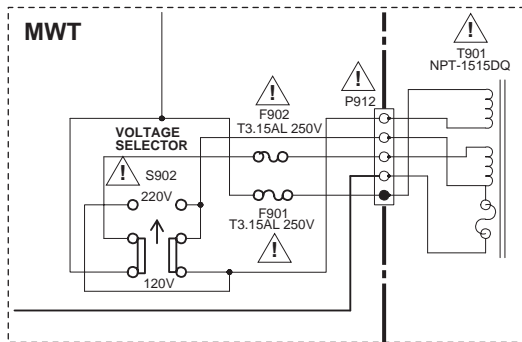
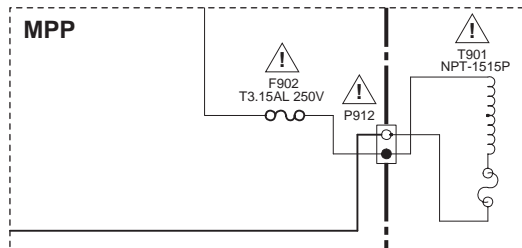
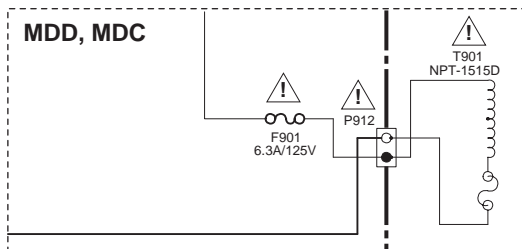

DESTINATION	AC IN
MDD, MDC	120V / 60Hz
MWT	120V / 220-230V 50/60Hz
MPP	230-240V / 50Hz

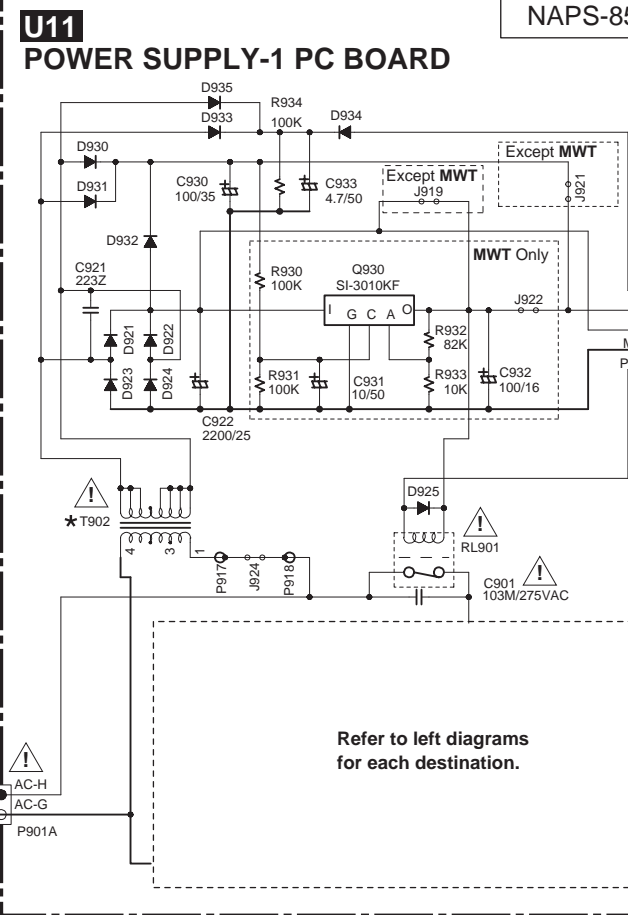

Refer to left diagrams for each destination.

1

2

3

4

5

NAPS-8546

U13

POWER SUPPLY-2 PC BOARD

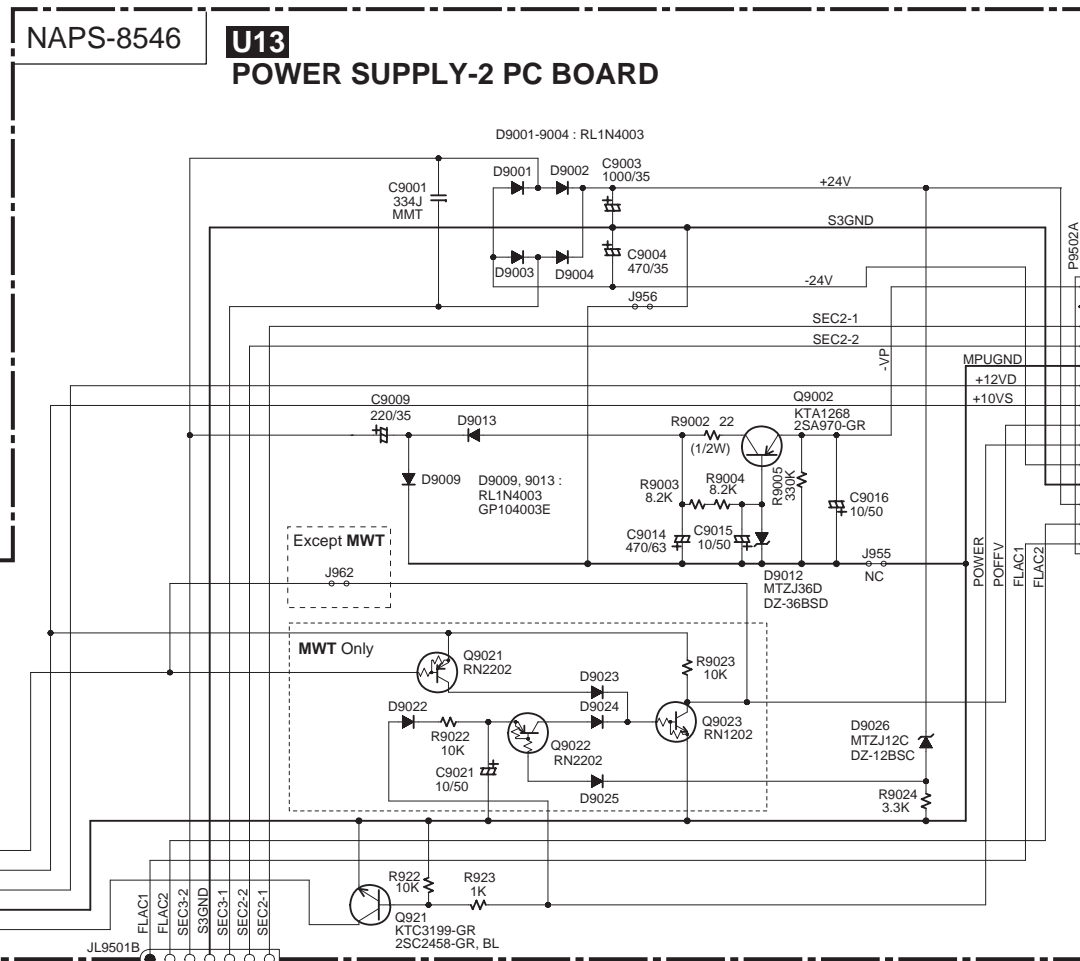

-8544

P831B
POFFVFP
+10VS
+12VD
MPUGND
POWERD

TO NAAF-8523

T901

NAPS-8547

U14

SEC. TERMINAL-1 PC BOARD

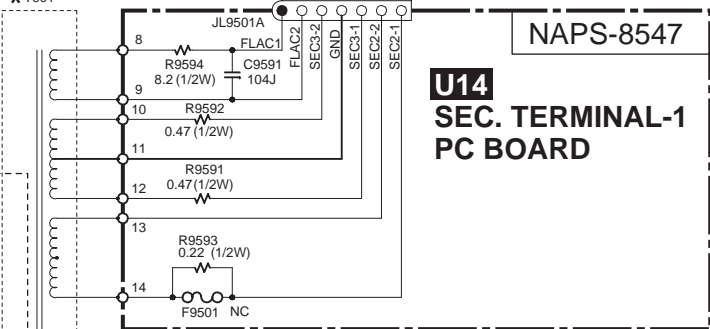

NAETC-8524

U06

SEC. TERMINAL-2 PC BOARD

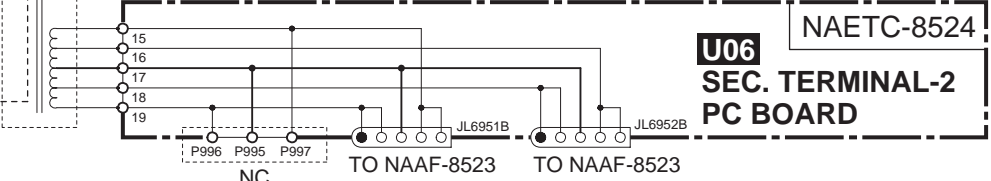

NC

TO NAAF-8523

TO NAAF-8523

SCHEMATIC DIAGRAMS-6
POWER SUPPLY SECTION

- NOTE**
- THE COMPONENTS IDENTIFIED BY MARK ARE CRITICAL FOR SAFETY. REPLACE ONLY WITH PART NUMBER SPECIFIED.
 - VOLTAGE (MEASURED WITH VOLTMETER) IS DC VOLTAGE.(NO INPUT SIGNAL).
 - ALL PNP TRANSISTORS ARE EQUIVALENT TO 2SA1015-GR UNLESS OTHERWISE NOTED.
 - ALL NPN TRANSISTORS ARE EQUIVALENT TO 2SC1815-GR UNLESS OTHERWISE NOTED.
 - ALL DIODES ARE EQUIVALENT TO 1S1133 UNLESS OTHERWISE NOTED.
 - ELECTROLYTIC CAPACITORS () ARE IN uF/WV.
 - ALL CAPACITORS ARE IN pF/50WV UNLESS OTHERWISE NOTED.
EX) 030- 3pF 330- 33pF 331- 330pF 333- 0.033uF
 - ALL RESISTORS ARE IN OHMS 1/4WATTS UNLESS OTHERWISE NOTED.
 - THE THICK LINES ON PC BOARD ARE THE PRINTING SIDE OF THE PARTS.
EX) PRINTING SIDE
 - CIRCUIT IS SUBJECT TO CHANGE FOR IMPROVEMENT.

<Note>
NC=No mount of parts.

Refer to following table about the parts displayed by mark "*".

CIRCUIT NO.	T902
DESTINATION	
MDD, MDC	NPT-1520JQ
MWT	NPT-1519JQ
MPP	NPT-1519GQ

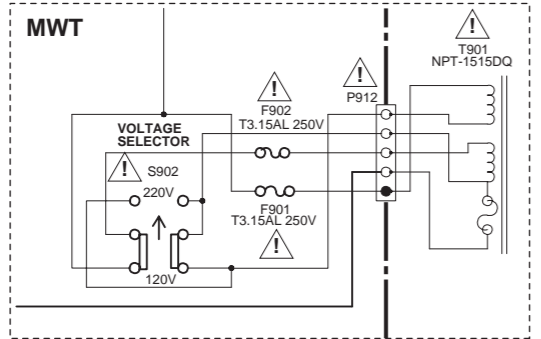
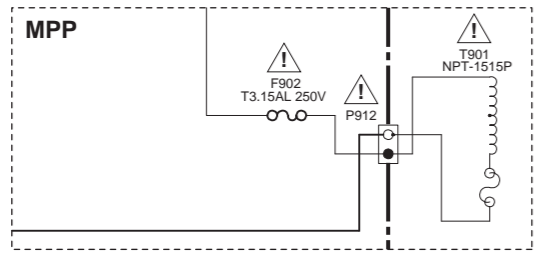
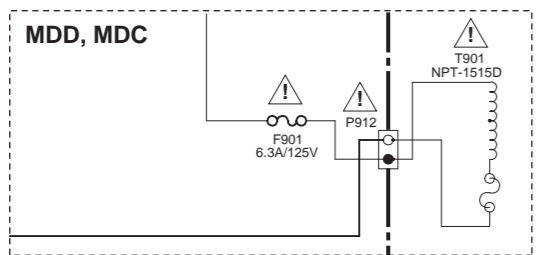

DESTINATION	AC IN
MDD, MDC	120V / 60Hz
MWT	120V / 220-230V 50/60Hz
MPP	230-240V / 50Hz

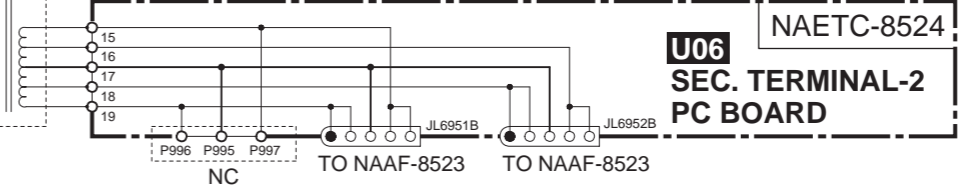
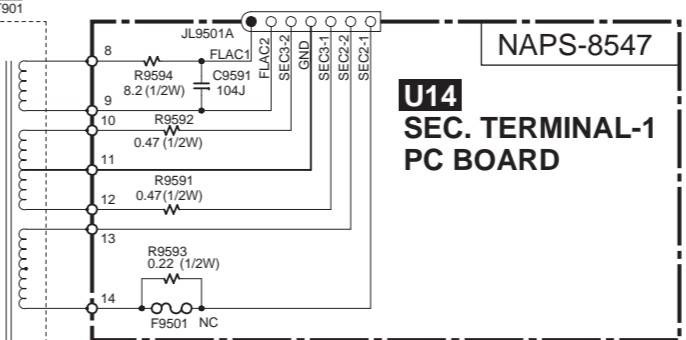
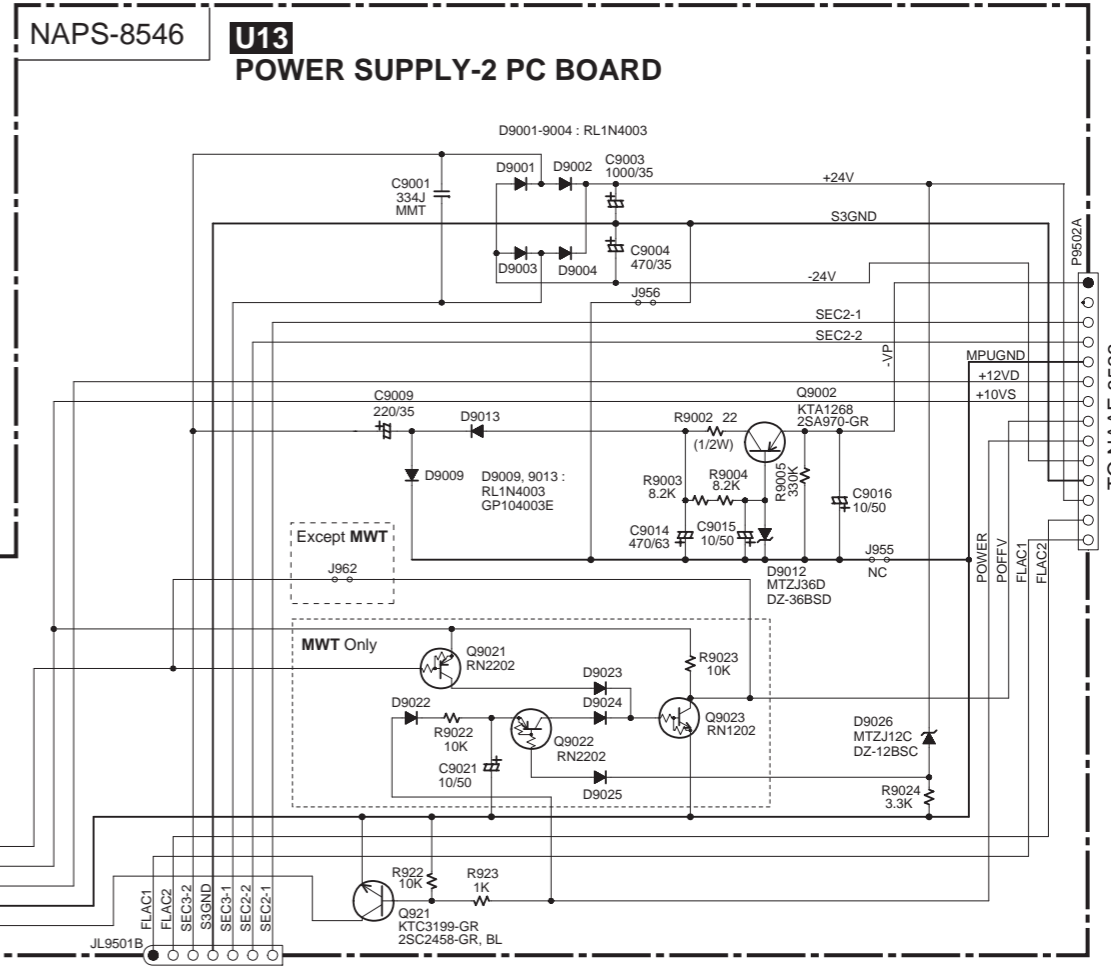
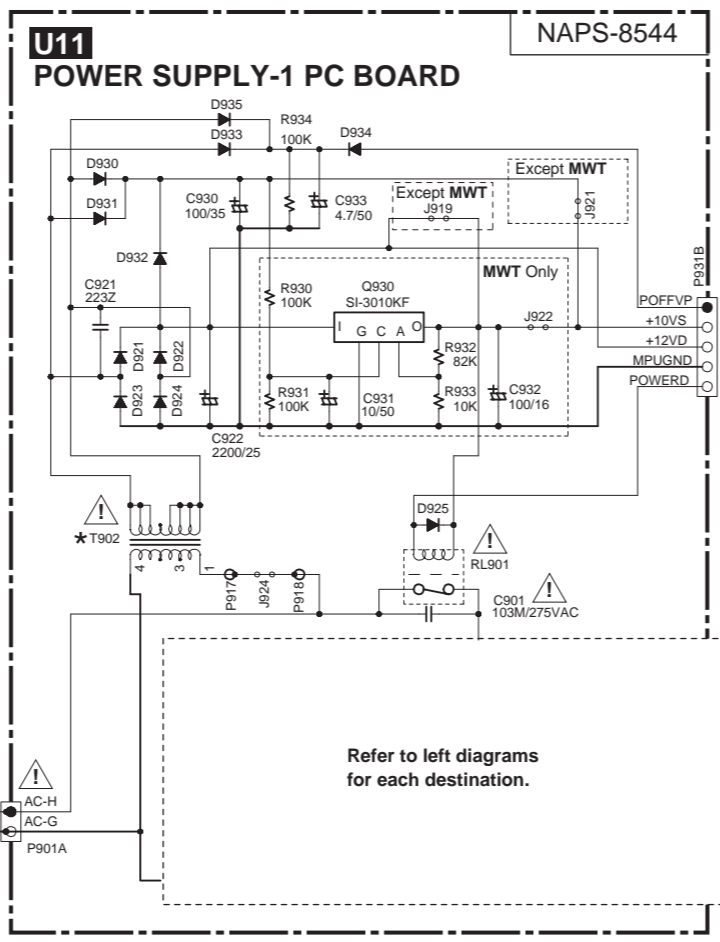
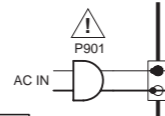

Refer to left diagrams for each destination.

TO NAAF-8523

TO NAAF-8523 TO NAAF-8523

A B C D
SCHEMATIC DIAGRAMS-7
DISPLAY SECTION

1

2

3

4

5

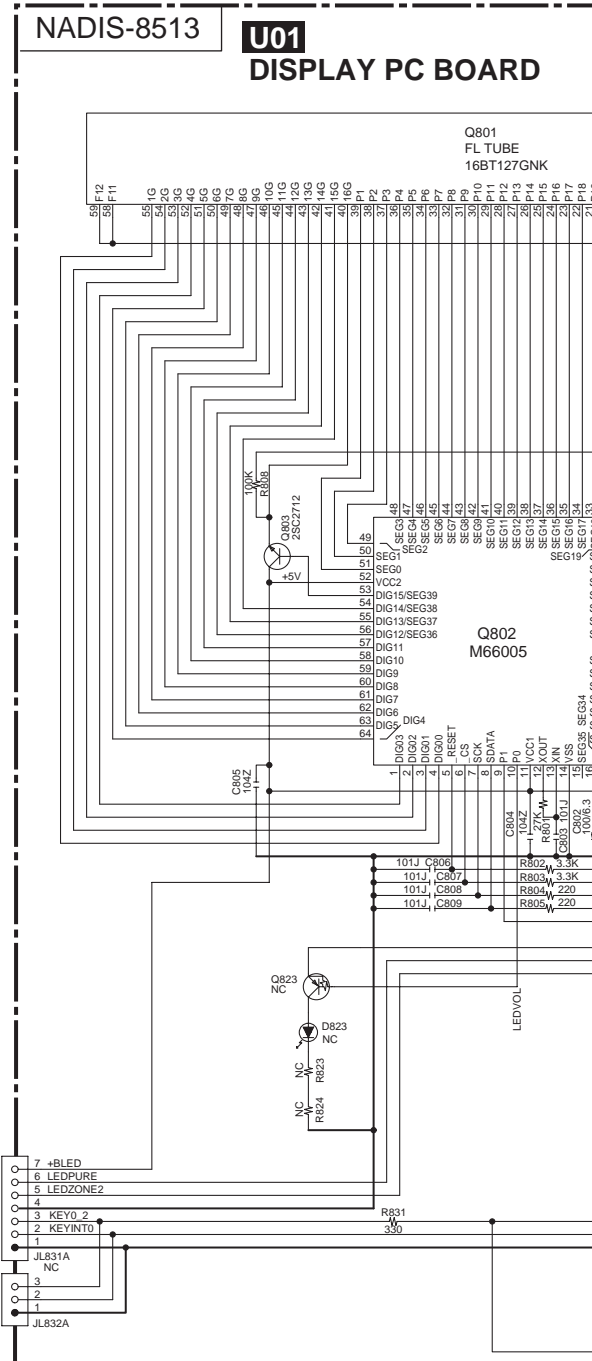
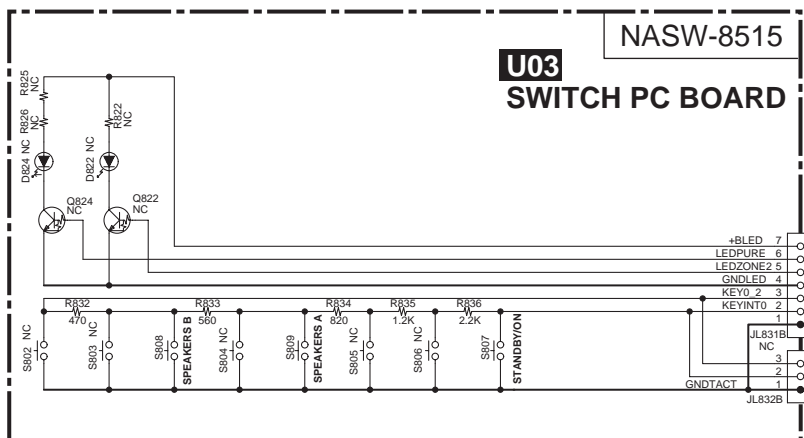
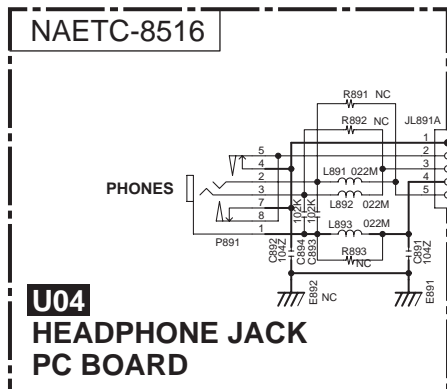

NOTE

- THE COMPONENTS IDENTIFIED BY MARK Δ ARE CRITICAL FOR SAFETY REPLACE ONLY WITH PART NUMBER SPECIFIED.
- VOLTAGE (MEASURED WITH VOLTMETER) \triangleleft IS DC VOLTAGE.(NO INPUT SIGNAL).
- ALL PNP TRANSISTORS ARE EQUIVALENT TO 2SA1015-GR UNLESS OTHERWISE NOTED.
- ALL NPN TRANSISTORS ARE EQUIVALENT TO 2SC1815-GR UNLESS OTHERWISE NOTED.
- ALL DIODES ARE EQUIVALENT TO 1SS133 UNLESS OTHERWISE NOTED.
- ELECTROLYTIC CAPACITORS (---) ARE IN uF/WV.
- ALL CAPACITORS ARE IN pF/50WV UNLESS OTHERWISE NOTED.
EX) 030- 3pF 330- 33pF 331- 330pF 333- 0.033uF
- ALL RESISTORS ARE IN OHMS 1/4WATTS UNLESS OTHERWISE NOTED.
- THE THICK LINES ON PC BOARD ARE THE PRINTING SIDE OF THE PARTS.
- EX) $\square \square \square$ PRINTING SIDE
- CIRCUIT IS SUBJECT TO CHANGE FOR IMPROVEMENT.

<Note>

NC=No mount of parts.

Refer to following table about the parts displayed by mark "★".

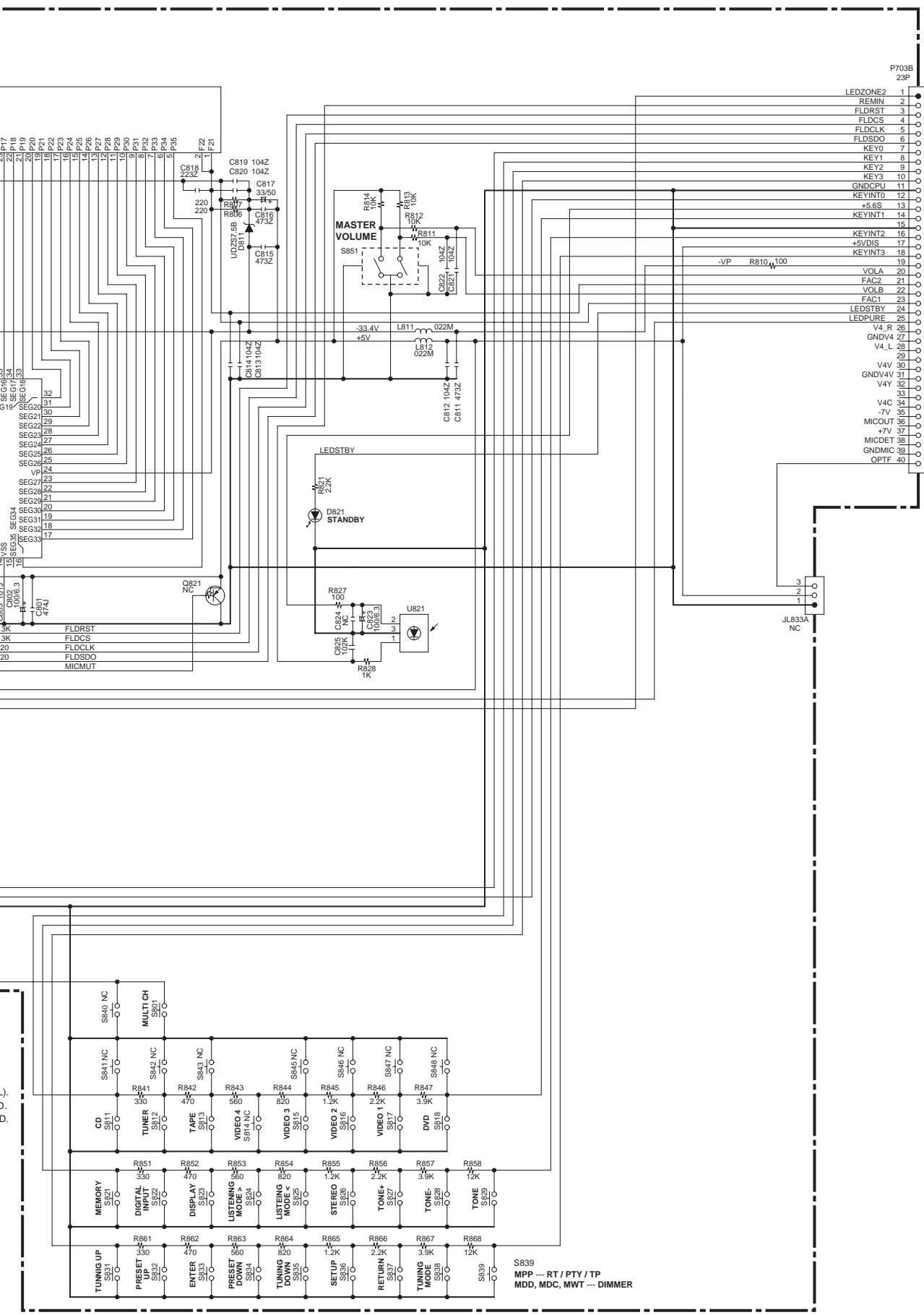

P703B
23P

- LEDZONE2 1
- REMIN 2
- FLDRST 3
- FLDCS 4
- FLDCLK 5
- FLDSDO 6
- KEY0 7
- KEY1 8
- KEY2 9
- KEY3 10
- GNDCPU 11
- KEYINT0 12
- +5.6S 13
- KEYINT1 14
- 15
- KEYINT2 16
- +5VDIS 17
- KEYINT3 18
- 19
- VP R810,100
- VOLA 20
- FAC2 21
- VOLB 22
- FAC1 23
- LEDSTBY 24
- LEDPURE 25
- V4_R 26
- GNDV4 27
- V4_L 28
- 29
- V4V 30
- GNDV4V 31
- V4Y 32
- 33
- V4C 34
- 7V 35
- MICOUT 36
- +7V 37
- MICDET 38
- GNDMIC 39
- OPTF 40

TO NADG-8514

JL833A
NC

S839
MPP -- RT / PTY / TP
MDD, MDC, MWT -- DIMMER

**SCHEMATIC DIAGRAMS-7
DISPLAY SECTION**

1

2

3

4

5

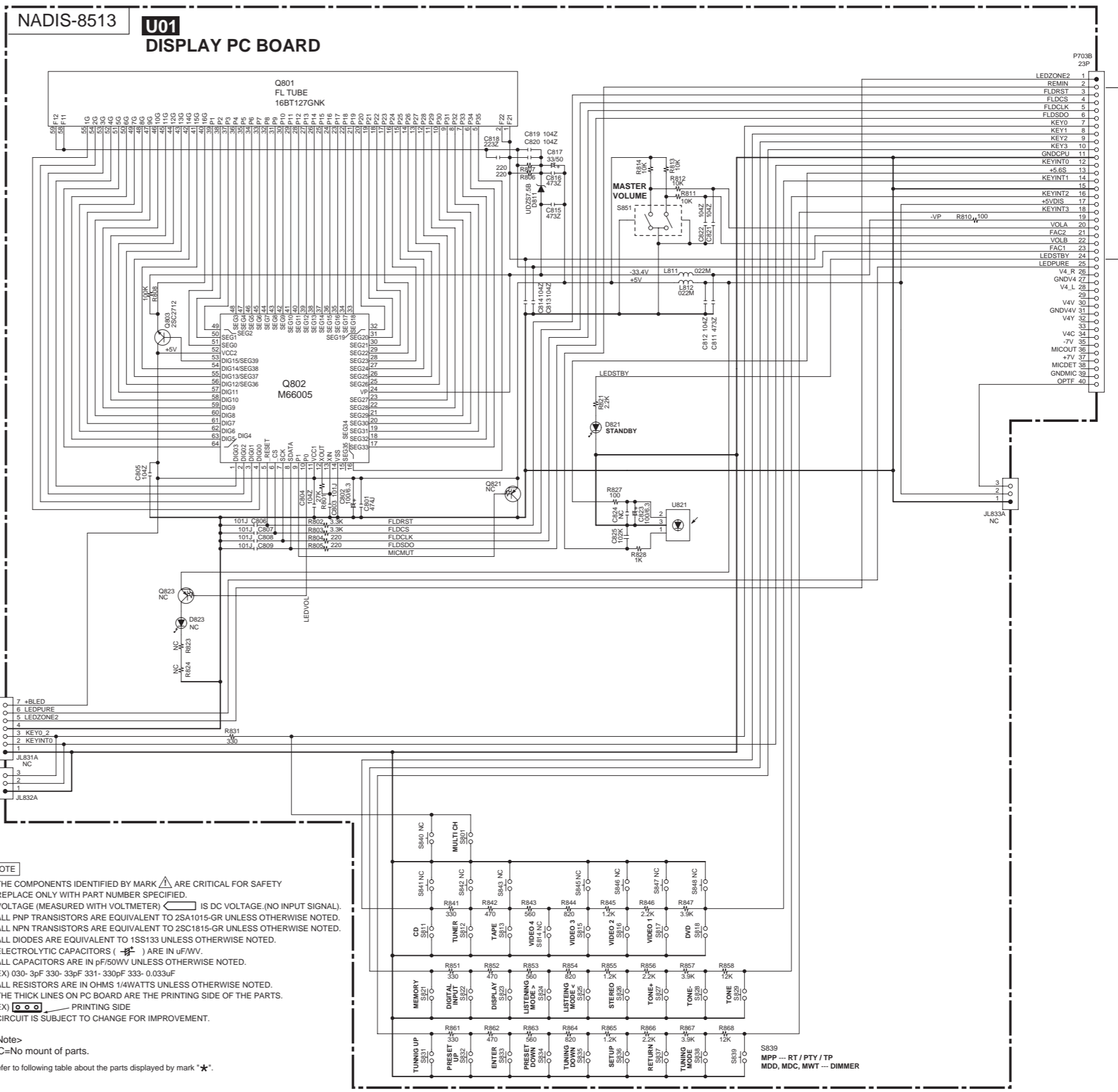
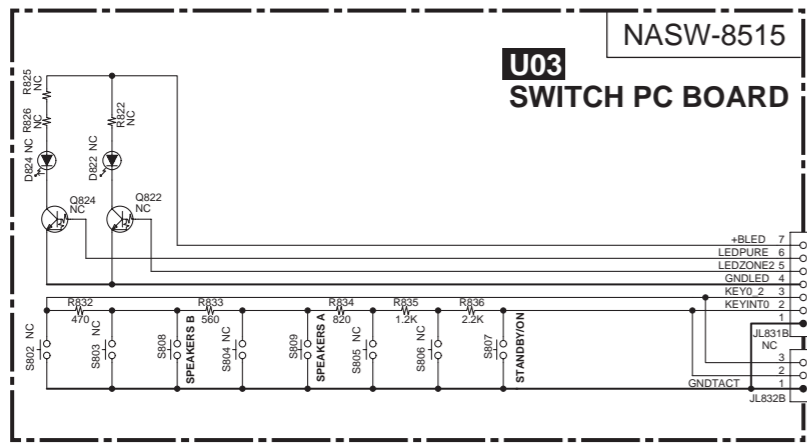
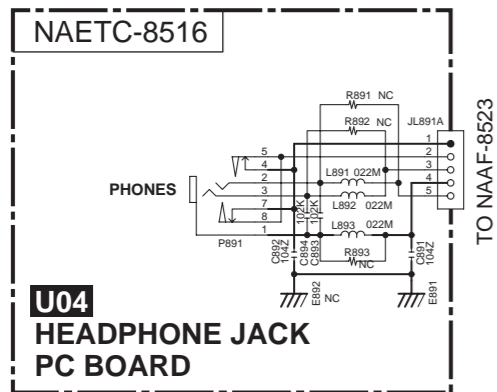

NOTE

- THE COMPONENTS IDENTIFIED BY MARK Δ ARE CRITICAL FOR SAFETY. REPLACE ONLY WITH PART NUMBER SPECIFIED.
- VOLTAGE (MEASURED WITH VOLTMETER) \leftarrow IS DC VOLTAGE (NO INPUT SIGNAL).
- ALL PNP TRANSISTORS ARE EQUIVALENT TO 2SA1015-GR UNLESS OTHERWISE NOTED.
- ALL NPN TRANSISTORS ARE EQUIVALENT TO 2SC1815-GR UNLESS OTHERWISE NOTED.
- ALL DIODES ARE EQUIVALENT TO 1SS133 UNLESS OTHERWISE NOTED.
- ELECTROLYTIC CAPACITORS (---) ARE IN $\mu\text{F/WV}$.
- ALL CAPACITORS ARE IN pF/50V UNLESS OTHERWISE NOTED.
EX) 030-3pF 330-33pF 331-330pF 333-0.033 μF
- ALL RESISTORS ARE IN OHMS 1/4WATTS UNLESS OTHERWISE NOTED.
- THE THICK LINES ON PC BOARD ARE THE PRINTING SIDE OF THE PARTS.
EX) \square PRINTING SIDE
- CIRCUIT IS SUBJECT TO CHANGE FOR IMPROVEMENT.

<Notes>
NC=No mount of parts.
Refer to following table about the parts displayed by mark *★.

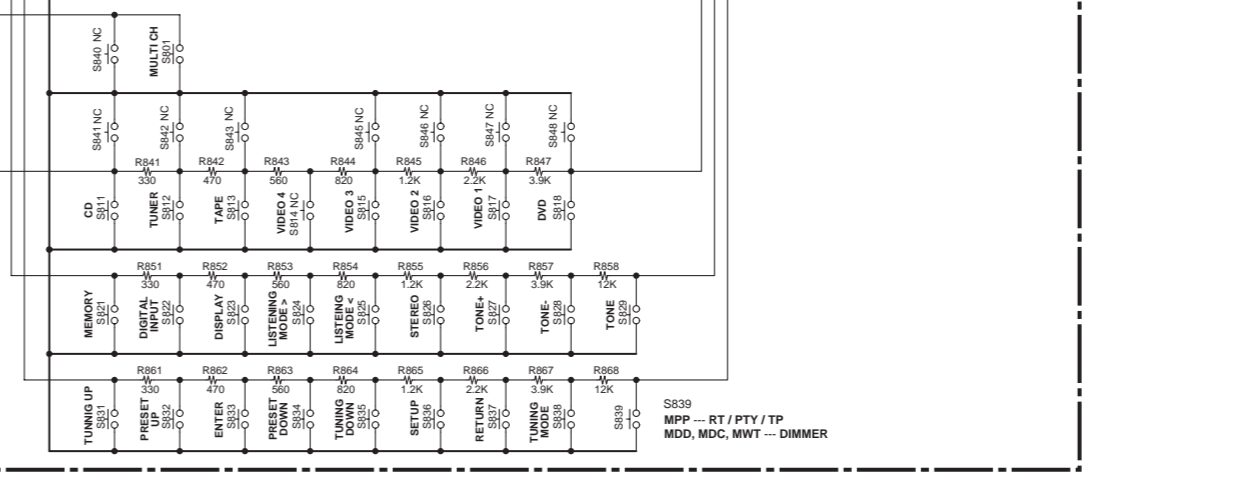

A B C D
SCHEMATIC DIAGRAMS-8
VIDEO SECTION

1

2

3

4

5

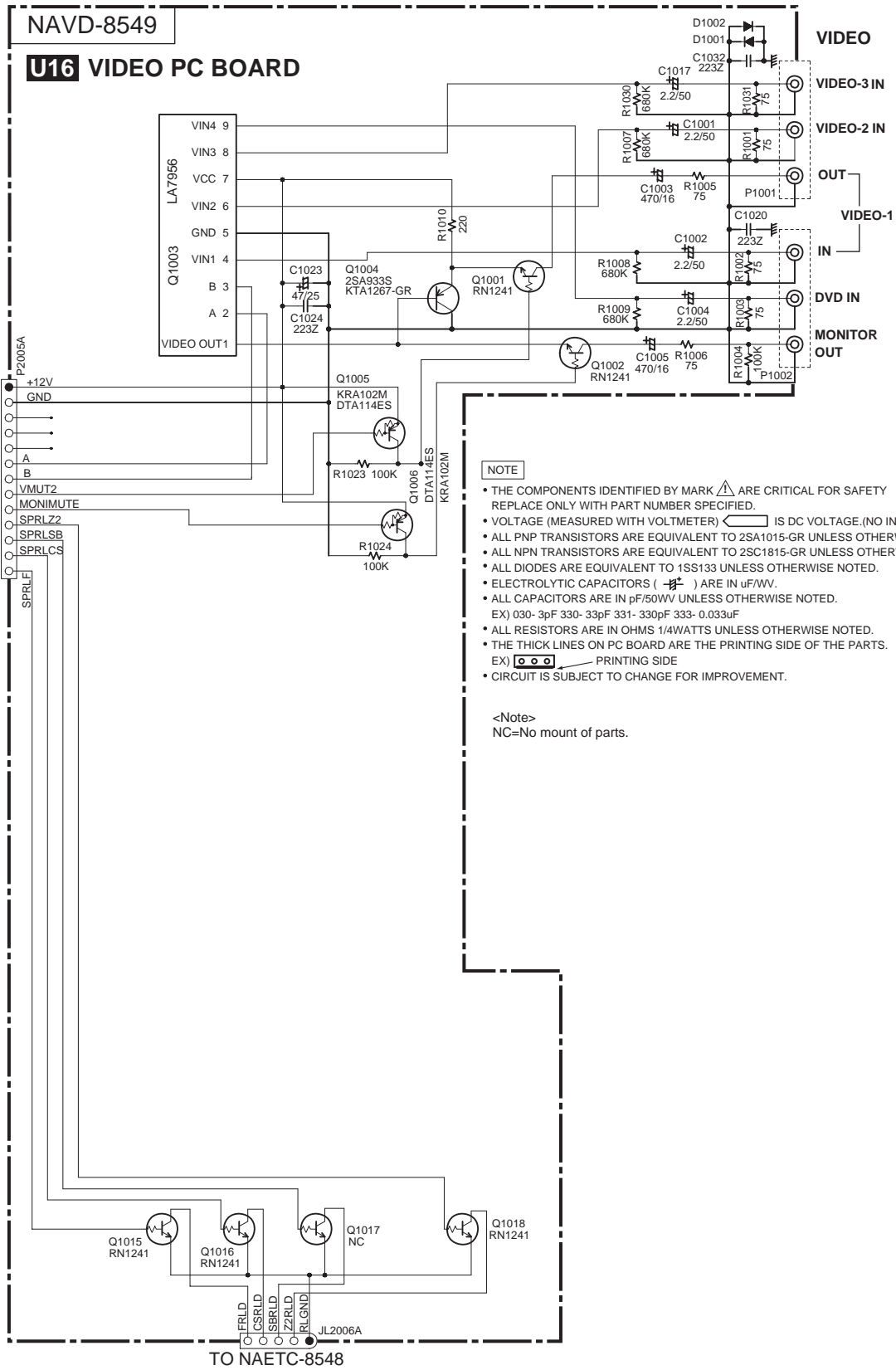



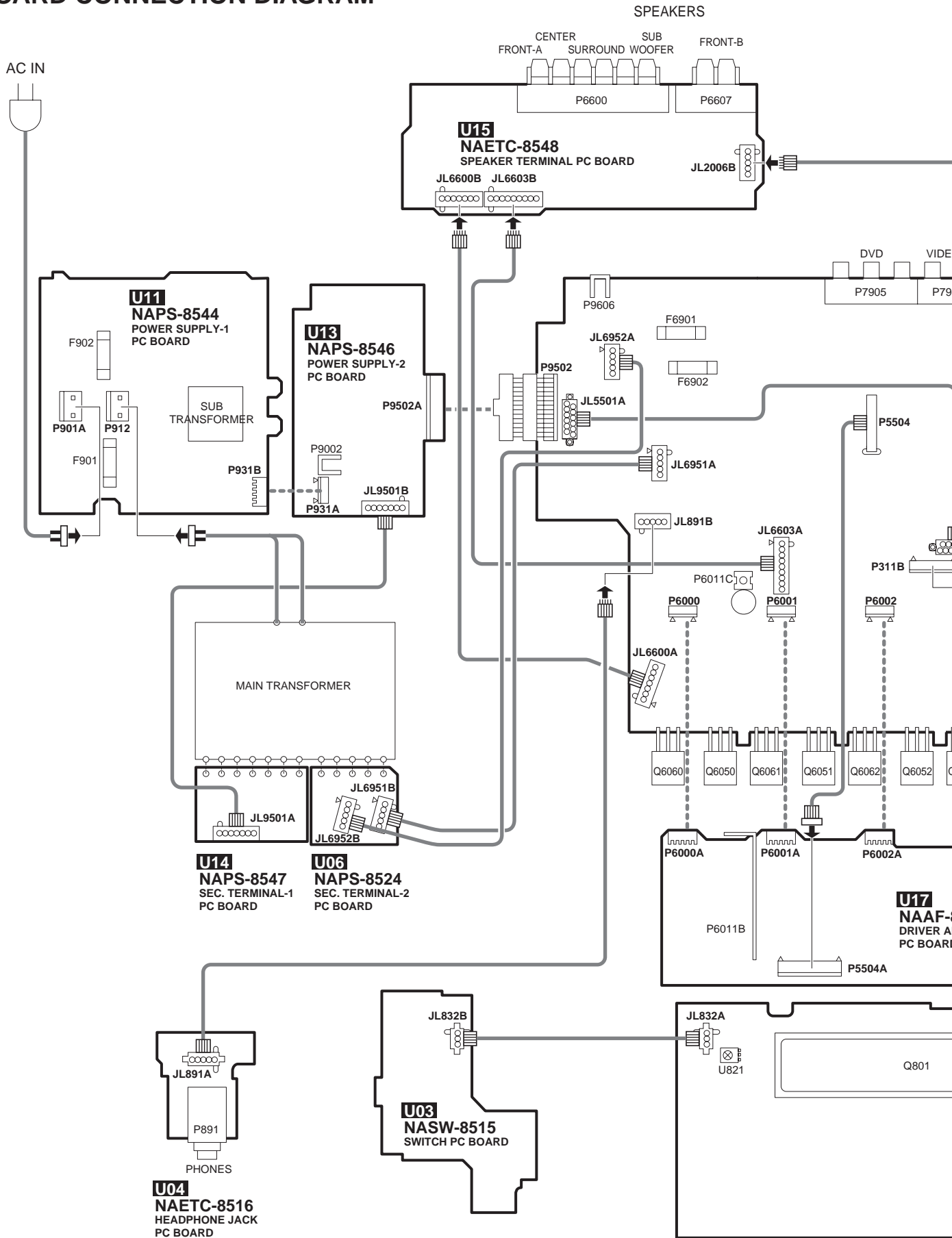

TO NAETC-8548

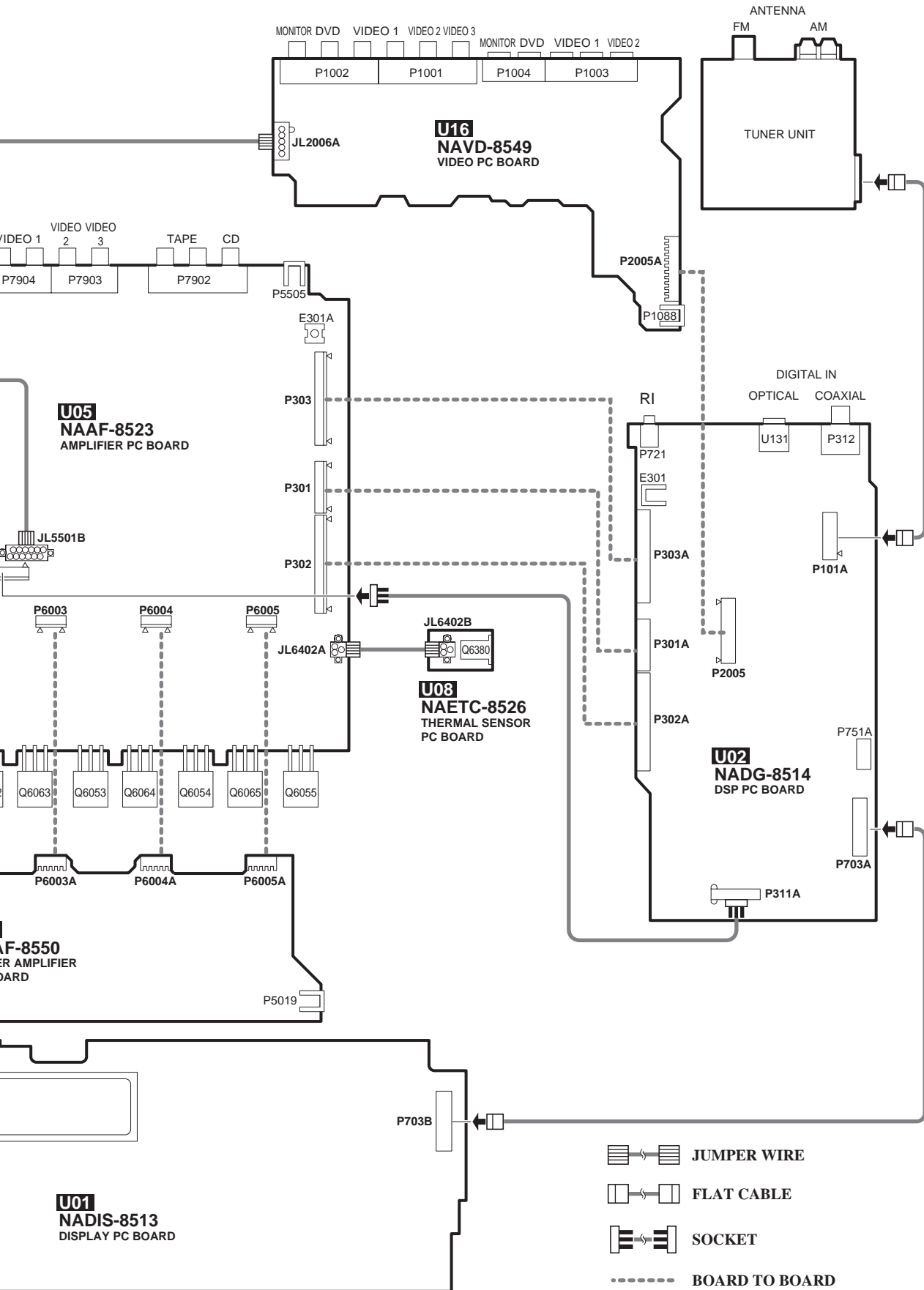
PC BOARD CONNECTION DIAGRAM





-  JUMPER WIRE
-  FLAT CABLE
-  SOCKET
-  BOARD TO BOARD

MICROPROCESSOR TERMINAL DESCRIPTIONS-1

Q701: M30622MGP-236FPU0

Pin No.	Pin name	I/O	Act.	Description
1	FLDSDO	O	H	Output serial data for control of FL driver IC.
2	FLDCLK	O	CLK	Output serial clock for control of FL driver IC.
3	FLDCS	O	H	Output chip select for FL driver IC.
4	~FLDRST	O	L	Output reset signal for FL driver IC.
5	FSWSDO	O	H	Output serial data for control of function switch (NJU7311).
6	FSWSTB	O	H	Output strobe for control of function switch (NJU7311).
7	FSWCLK	O	H	Output serial clock for control of function switch (NJU7311).
8	BYTE	---	---	Select of external bus width. Connect to ground.
9	CNVSS	---	---	Select of processor mode.
10	NU	---	---	Not used.
11	NU	---	---	Not used.
12	~RESET	I	L	Input signal for system reset.
13	XOUT	---	---	Connected to oscillator.
14	VSS	---	---	Ground.
15	XIN	---	---	Connected to oscillator.
16	VCC1	---	---	Power supply.
17	NU	---	---	Not used.
18	NU	---	---	Not used.
19	~REMIN	I	L	Input signal from remote sensor.
20	POFF	I	H	Input signal of power failure detection.
21	NU	---	---	Not used.
22	DIRINT0	I	H	Input signal of interrupt request detection of DSP C.
23	~DIRCS	O	L	Output signal for chip select of DIR/CODEC.
24	~DIRRST	O	L	Output signal for reset of DIR/CODEC.
25	~DSPFCS	O	L	Output signal for chip select of DSP A/B.
26	~DSPCS	O	L	Output signal for chip select of DSP C.
27	VMUTMON	O	L	Output control signal for video mute of monitor out.
28	VMUTV1	O	L	Output control signal for video mute of video-1.
29	VCTRLA	O	H	Output control signal of video switch IC.
30	VCTRLB	O	H	Output control signal of video switch IC.
31	FTXD	O	H	For writing of flash microprocessor.
32	FRXD	I	H	For writing of flash microprocessor.
33	FCLK	O	CLK	For writing of flash microprocessor.
34	FBUSY	O	H	Output reset signal for DSPIC.
35	DIGSDO	O	H	Output signal for serial communications with DIR/ CODEC/DSP IC.
36	DIGSDI	I	H	Input signal for serial communications with DIR/ CODEC/DSP IC.
37	DIGCLK	O	CLK	Output clock for serial communications with DIR/ CODEC/DSP IC.
38	DSPBUSY	I	H	Input signal of detect busy signal of DSP C.
39	~DSPINT	I	L	Input signal of detect interrupt request signal of DSP C.
40	~DSPFINT	I	L	Input signal of detect interrupt request signal of DSP AB.
41	~FEPM	O	H	For writing of flash microprocessor.
42	~DSPRST	O	L	Output reset signal for DSP IC.
43	VOLSTB	O	H	Output strobe for control of volume IC.
44	VOLCLK	O	CLK	Output serial clock for control of volume IC.
45	VOLDAT	O	H	Output serial data for control of volume IC.
46	~FCE	I	H	For writing of flash microprocessor.
47	NU	---	---	Not used.
48	NU	---	---	Not used.
49	AMUT	O	H	Output signal of audio mute.
50	SPRLB	O	H	Output control signal for relay drive of speakers-B.

MICROPROCESSOR TERMINAL DESCRIPTIONS-2

Q701: M30622MGP-236FPU0

Pin No.	Pin name	I/O	Act.	Description
51	SPRLSB	O	H	Output control signal for relay drive of surround back speakers.
52	SPRLCS	O	H	Output control signal for relay drive of center and surround speakers.
53	SPRLF/SPRLSW	O	H	Output control signal for relay drive of front speakers and subwoower speaker.
54	TUMUT	O	H	Output signal of tuner mute.
55	PLLCE	O	H	Output chip enable for PLL IC of tuner.
56	PLLSDO	O	H	Output serial data for PLL IC of tuner.
57	PLLCLK	O	CLK	Output serial clock for PLL IC of tuner.
58	~STEREO/PLLSDI	I	L	Input detection of stereo signal, and serial data of PLL IC.
59	~SD	I	L	Input detection signal of demodulation of tuner.
60	VPOWER	O	H	Output control signal of power supply of the video circuit.
61	APOWER	O	H	Output control signal of main power supply.
62	VCC2	---	---	Power supply.
63	SEC1H	O	H	Output control signal for power supply of amplifier section.
64	VSS	---	---	Ground.
65	VOLH	I	A/D	Input detection signal of speaker output level.
66	THERMAL	I	A/D	Input detection signal of thermal detection.
67	PROTECT	I	H	Input detection signal of over current of speaker output.
68	FANCTRL	O	L	Output control signal of cooling fan. Function control.
69	FANH	O	L	Output control signal of cooling fan. Speed control.
70	NU	---	---	Not used.
71	RDSDAT	I	H	Input serial data of RDS. MPP(European model) only.
72	RDSSIG	I	H	Input detection signal of demodulation of RDS. MPP(European model) only.
73	SYSIN	I	H	Input signal of RI (system control).
74	NU	---	---	Not used.
75	~RDSCLK	I	L	Input serial clock of RDS. MPP(European model) only.
76	~SYSOUT	O	L	Output signal of RI (system control).
77	NU	---	---	Not used.
78	NU	---	---	Not used.
79	~LEDSTBY	O	L	Output control signal of Standby LED.
80	HPRL	O	H	Output control signal for relay drive of headphone.
81	HPDET	I	H	Input detection signal of headphone state.
82	NU	---	---	Not used.
83	VOLB	I	H	Input signal of rotary encoder.
84	VOLA	I	H	Input signal of rotary encoder.
85	INIT3	I	A/D	For initial setting-3.
86	INIT2	I	A/D	For initial setting-2.
87	INIT1	I	A/D	For initial setting-1.
88	BAND	I	A/D	For initial setting of tuner band and step.
89	~KEYINT3	I	L	Input signal of operation keys.
90	~KEYINT2	I	L	Input signal of operation keys.
91	~KEYINT1	I	L	Input signal of operation keys.
92	~KEYINT0	I	L	Input signal of operation keys.
93	KEY3	I	A/D	Input signal of operation keys.
94	KEY2	I	A/D	Input signal of operation keys.
95	KEY1	I	A/D	Input signal of operation keys.
96	AVSS	---	---	Ground for A/D.
97	KEY0	I	A/D	Input signal of operation keys.
98	VREF	---	---	Power supply for reference of A/D.
99	AVCC	---	---	Power supply.
100	NU	---	---	Not used.

ADJUSTMENT PROCEDURE-1

IDLING CURRENT ADJUSTMENT

[When]

1. Exchange power transistors (Q6050 - Q6065).
2. Exchange amplifier PC board ass'y (NAAF-8523).

[Procedure]

<Note> No load and No signal

Refer to "ADJUSTMENT PROCEDURES-2" about the adjustment points and the measuring points.

1. Before Idling adjustment, turn the trimming resistors to counter clockwise.
2. Connect the DC voltmeter to test points.
Connect 100-ohm resistance near the terminal of the two poles of a Jig terminal.

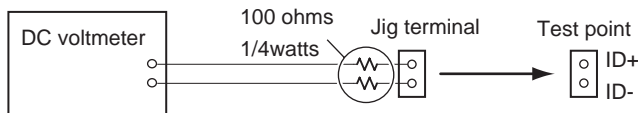

3. Connect the AC power cord to wall outlet.
4. Press the STANDBY/ON button into the power on.
5. Adjust the trimming resistors as following procedure immediately after power on.

Channel	Mark	Adjustment point (Trimming resistor)	Measuring point (Test point)	Adjustment value
Left	<input type="text" value="L"/>	R6040	P6080	2.5 mV
Right	<input type="text" value="R"/>	R6041	P6081	2.5 mV
Center	<input type="text" value="C"/>	R6042	P6082	2.5 mV
Surround Left	<input type="text" value="SL"/>	R6043	P6083	1.5 mV
Surround Right	<input type="text" value="SR"/>	R6044	P6084	1.5 mV
Subwoofer	<input type="text" value="SBL"/>	R6045	P6085	1.5 mV

6. Wait for 4 - 6 minutes. (Heat running)
7. Re-adjust the trimming resistors as following procedure.

Channel	Adjustment point	Measured value	Adjustment value	Specifications (* In a stable state)
Left, Right and Center	R6040, R6041 and R6042	In case below 9 mV →	9 mV	12 +/- 3 mV
		In case 9 - 11 mV →	Leave it as it is	
		In case over 11 mV →	11 mV	
Surround Left, Surround Right and Subwoofer	R6043, R6044 and R6045	In case below 6 mV →	6 mV	9 +/- 3 mV
		In case 6 - 8 mV →	Leave it as it is	
		In case over 8 mV →	8 mV	

* Idling current are stabilized in about 10 minutes after a power supply on.

8. Disconnect the DC voltmeter.
9. Press the STANDBY/ON button into the power off.
10. Disconnect the AC power cord.

ADJUSTMENT PROCEDURE-2 IDLING CURRENT ADJUSTMENT

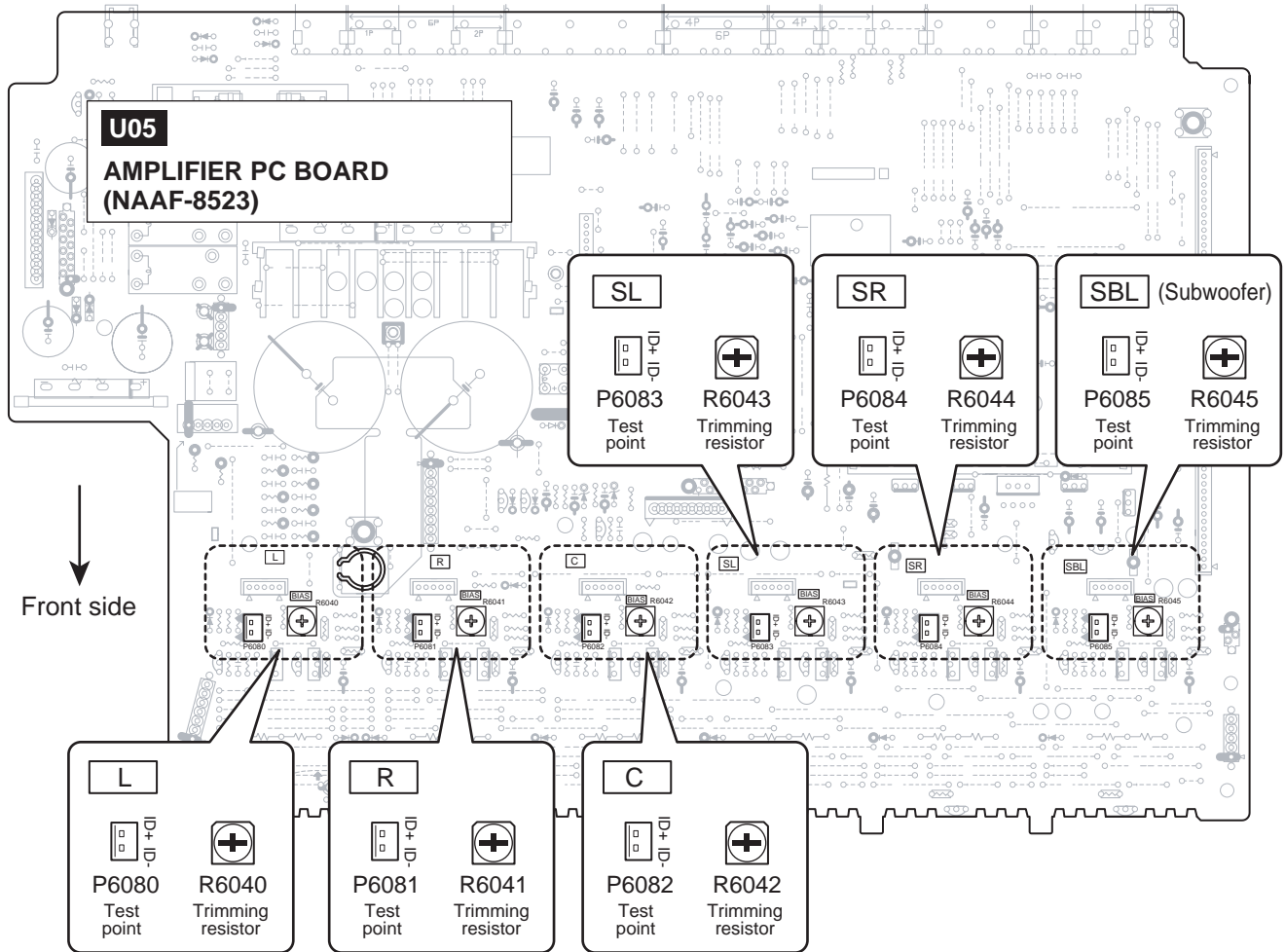

ONKYO CORPORATION

Sales & Product Planning Div. : 2-1, Nisshin-cho, Neyagawa-shi, OSAKA 572-8540, JAPAN
Tel: 072-831-8023 Fax: 072-831-8124

ONKYO U.S.A. CORPORATION

18 Park Way, Upper Saddle River, N.J. 07458, U.S.A.
Tel: 201-785-2600 Fax: 201-785-2650 <http://www.us.onkyo.com/>

ONKYO EUROPE ELECTRONICS GmbH

Liegnitzerstrasse 6, 82194 Groebenzell, GERMANY
Tel: +49-8142-4401-0 Fax: +49-8142-4401-555 <http://www.eu.onkyo.com/>

ONKYO EUROPE UK Office

Suite 1, Gregories Court, Gregories Road, Beaconsfield, Buckinghamshire, HP9 1HQ
UNITED KINGDOM Tel: +44-(0)1494-681515 Fax: +44(0)-1494-680452

ONKYO CHINA LIMITED

Units 2102-2107, Metroplaza Tower I, 223 Hing Fong Road, Kwai Chung,
N.T., HONG KONG Tel: 852-2429-3118 Fax: 852-2428-9039
<http://www.ch.onkyo.com/>



HT-R330

NOTE : THE COMPONENTS IDENTIFIED BY THE MARK
! ARE CRITICAL FOR RISK OF FIRE AND
ELECTRIC SHOCK. REPLACE ONLY WITH PART
NUMBER SPECIFIED.

<Notes>

<DD> : USA model only
<DC> : Canadian model only
<WT> : World wide model only
<PP> : European model only

EXPLODED VIEW PARTS LIST

	REF. NO.	PART NAME	DESCRIPTION	Q'TY	PART NO (SN)	REMARKS
EXP	A001	RETAINER	(F)	1	27141972	
EXP	A004	SCREW	3TTB+8B(CU)SR	20	801618	
EXP	A003	SCREW	3TTB+8B(BC)	35	838430088	
EXP	A002	SCREW	3TTB+10B(BC)	14	838430108	
EXP	A010	CHASSIS	---	1	27100460A	
EXP	A011	TAPE	TAPE(CLOTH-16U)	(1)	29110083	
EXP	A013	WIRE TIE	BSK-1	6	260208	
EXP	A014	CLIP	CS-1U	2	27255004	
EXP	A015	HOLDER	KGLS-14RT	3	27190524	
EXP	A016	HOLDER	HOLDER	2	27190991	
EXP	A023	SCREW	4TTC+8C(BC)	4	830440089	
EXP	A025	TAPE	TAPE(CLOTH-16U)	(1)	29110083	
EXP	A028	BUSHING	S-RELIEF #2271	1	27300750	!
EXP	A030	HEAT SINK	AS.	1	27160563B	
EXP	A037	SCREW	3SMS8W.SW+14B(BC)	12	801433	
EXP	A040	BRACKET	(U)	1	27130986	
EXP	A045	SHLD PLT	(R)	1	27150504	
EXP	A046	PLA RIVET	P3035B	1	880016	
EXP	A048	CUSHION	13 x 50 x 10	2	28141563	
EXP	A050	COVER	---	1	28184926	
EXP	A051	SCREW	3TTB+8B(UN)	6	838930088	
EXP	A052	LABEL	(COVER)	1	29364123	
EXP	A055	LEG	LEG	4	27175319B	
EXP	A056	CUSHION	---	8	28141494	
EXP	A065	CLEAR PLT	---	1	28192065A	
EXP	A401	REAR PANEL	HT-R330MDD	1	27123405	<DD>
EXP	A401	REAR PANEL	HT-R330MDD	1	27123405	<DC>
EXP	A401	REAR PANEL	HT-R330MWT	1	27123406A	<WT>
EXP	A401	REAR PANEL	HTR330MPP	1	27123453	<PP>
EXP	A402	LABEL	(WEEE)	1	29364199	<PP>
EXP	A405	F PANEL	---	1	27212768A	<DD>
EXP	A405	F PANEL	---	1	27212768A	<DC>
EXP	A405	F PANEL	---	1	27212768A	<WT>
EXP	A405	F PANEL	---	1	27212788	<PP>
EXP	A406	FACET	(ST)	1	28198998A	
EXP	A411	KNOB	(POW)	1	28326299	
EXP	A412	KNOB	(SEL)	1	28326303	
EXP	A413	KNOB	(PRE)	1	28326306	
EXP	A420	BADGE	---	1	28135298	
EXP	A425	RETAINER	(BRO)	1	27141873	<PP>
EXP	A430	KNOB	(VOL)AS	1	28326319	

EXP	A450	LABEL	HOOKUP-ONKYO	1	29363194	<DD>
EXP	F901	FUSE	6.3A-UL/T-237	1	252166	!, <DD, DC>
EXP	F901 or	FUSE	6.3A-T/UL-ST2	(1)	252260	!, <DD, DC>
EXP	F901	FUSE	3.15A-SE-EAK FUSE	1	252076	!, <WT>
EXP	F901 or	FUSE	3.15A-SE-TL250V	(1)	252242	!, <WT>
EXP	F901 or	FUSE	3.15A-SE-TL250V	(1)	252276	!, <WT>
EXP	F901C	FUSE LABEL	T3.15AL250V	1	29362779	<WT>
EXP	F902	FUSE	3.15A-SE-EAK FUSE	1	252076	!, <WT, PP>
EXP	F902 or	FUSE	3.15A-SE-TL250V	(1)	252242	!, <WT, PP>
EXP	F902 or	FUSE	3.15A-SE-TL250V	(1)	252276	!, <WT, PP>
EXP	F6901	FUSE	8A-UL	1	252198	!
EXP	F6901 or	FUSE	8A-T/UL-ST2	(1)	252261	!
EXP	F6902	FUSE	8A-UL	1	252198	!
EXP	F6902 or	FUSE	8A-T/UL-ST2	(1)	252261	!
EXP	P101	FFC	NCFC7-150512	1	2047150512	
EXP	P703	FFC	NCFC5-232022	1	2045232022	
EXP	P901	AC CORD	AS-UC-2	1	253368LTK	!, <DD, DC>
EXP	P901 or	AC CORD	AS-UC-2	(1)	253333VOL	!, <DD, DC>
EXP	P901 or	AC CORD	AS-UC-2	(1)	253332HIT	!, <DD, DC>
EXP	P901	AC CORD	AS-CEE-2	1	253233KAW	!, <WT, PT>
EXP	P901 or	AC CORD	AS-CEE-2	(1)	253306VOL	!, <WT, PT>
EXP	P901 or	AC CORD	AS-CEE-2	(1)	253374LTK	!, <WT, PT>
EXP	Q6050	TR	2SC5198-O	1	2203063	
EXP	Q6050 or	TR	2SC5198-R	(1)	2203062	
EXP	Q6050 or	TR	MN130S-Y	(1)	2203664	
EXP	Q6050 or	TR	MN130S-P	(1)	2203666	
EXP	Q6050 or	TR	MN130S-O	(1)	2203663	
EXP	Q6050A	ISO SHEET	AC238	12	223024	
EXP	Q6051	TR	2SC5198-O	1	2203063	
EXP	Q6051 or	TR	2SC5198-R	(1)	2203062	
EXP	Q6051 or	TR	MN130S-Y	(1)	2203664	
EXP	Q6051 or	TR	MN130S-P	(1)	2203666	
EXP	Q6051 or	TR	MN130S-O	(1)	2203663	
EXP	Q6052	TR	2SC5198-O	1	2203063	
EXP	Q6052 or	TR	2SC5198-R	(1)	2203062	
EXP	Q6052 or	TR	MN130S-Y	(1)	2203664	
EXP	Q6052 or	TR	MN130S-P	(1)	2203666	
EXP	Q6052 or	TR	MN130S-O	(1)	2203663	
EXP	Q6053	TR	KTC5242A-O	1	2203953	
EXP	Q6053 or	TR	KTC5242A-R	(1)	2203952	
EXP	Q6053 or	TR	MN130S-Y	(1)	2203664	
EXP	Q6053 or	TR	MN130S-P	(1)	2203666	
EXP	Q6053 or	TR	MN130S-O	(1)	2203663	
EXP	Q6054	TR	KTC5242A-O	1	2203953	
EXP	Q6054 or	TR	KTC5242A-R	(1)	2203952	
EXP	Q6054 or	TR	MN130S-Y	(1)	2203664	
EXP	Q6054 or	TR	MN130S-P	(1)	2203666	
EXP	Q6054 or	TR	MN130S-O	(1)	2203663	
EXP	Q6055	TR	KTC5242A-O	1	2203953	
EXP	Q6055 or	TR	KTC5242A-R	(1)	2203952	
EXP	Q6055 or	TR	MN130S-Y	(1)	2203664	

EXP	Q6055 or	TR	MN130S-P	(1)	2203666	
EXP	Q6055 or	TR	MN130S-O	(1)	2203663	
EXP	Q6060	TR	2SA1941-O	1	2203053	
EXP	Q6060 or	TR	2SA1941-R	(1)	2203052	
EXP	Q6060 or	TR	MP130S-Y	(1)	2203674	
EXP	Q6060 or	TR	MP130S-P	(1)	2203676	
EXP	Q6060 or	TR	MP130S-O	(1)	2203673	
EXP	Q6061	TR	2SA1941-O	1	2203053	
EXP	Q6061 or	TR	2SA1941-R	(1)	2203052	
EXP	Q6061 or	TR	MP130S-Y	(1)	2203674	
EXP	Q6061 or	TR	MP130S-P	(1)	2203676	
EXP	Q6061 or	TR	MP130S-O	(1)	2203673	
EXP	Q6062	TR	2SA1941-O	1	2203053	
EXP	Q6062 or	TR	2SA1941-R	(1)	2203052	
EXP	Q6062 or	TR	MP130S-Y	(1)	2203674	
EXP	Q6062 or	TR	MP130S-P	(1)	2203676	
EXP	Q6062 or	TR	MP130S-O	(1)	2203673	
EXP	Q6063	TR	KTA1962A-O	1	2203943	
EXP	Q6063 or	TR	KTA1962A-R	(1)	2203942	
EXP	Q6063 or	TR	MP130S-Y	(1)	2203674	
EXP	Q6063 or	TR	MP130S-P	(1)	2203676	
EXP	Q6063 or	TR	MP130S-O	(1)	2203673	
EXP	Q6064	TR	KTA1962A-O	1	2203943	
EXP	Q6064 or	TR	KTA1962A-R	(1)	2203942	
EXP	Q6064 or	TR	MP130S-Y	(1)	2203674	
EXP	Q6064 or	TR	MP130S-P	(1)	2203676	
EXP	Q6064 or	TR	MP130S-O	(1)	2203673	
EXP	Q6065	TR	KTA1962A-O	1	2203943	
EXP	Q6065 or	TR	KTA1962A-R	(1)	2203942	
EXP	Q6065 or	TR	MP130S-Y	(1)	2203674	
EXP	Q6065 or	TR	MP130S-P	(1)	2203676	
EXP	Q6065 or	TR	MP130S-O	(1)	2203673	
EXP	<Note>					
EXP	Must use the same HFE rank mutually about the following parts.					
EXP	Ref. No. : Q6050 - 6060, Q6051 - 6061, Q6052 - 6062, Q6053 - 6063, Q6054 - 6064, Q6055 - 6065					
EXP	T901	P TRANS	NPT-1515D	1	2301796	!,<DD>
EXP	T901	P TRANS	NPT-1515D	1	2301796	!,<DC>
EXP	T901	P TRANS	NPT-1515DQ	1	2301797	!,<WT>
EXP	T901	P TRANS	NPT-1515P	1	2301819	!,<PP>
EXP	U01	DISPLAY PC board ass'y	NADIS-8513-1B	1	1B068513-1B	<DD, DC>
EXP	U01	DISPLAY PC board ass'y	NADIS-8513-1C	1	1B068513-1C	<WT>
EXP	U01	DISPLAY PC board ass'y	NADIS-8513-1Z	1	1B068513-1Z	<PP>
EXP	U02	DSP PC board ass'y	NADG-8514-1B	1	1B068514-1B	<DD, DC>
EXP	U02	DSP PC board ass'y	NADG-8514-1C	1	1B068514-1C	<WT>
EXP	U02	DSP PC board ass'y	NADG-8514-1Z	1	1B068514-1Z	<PP>
EXP	U03	SWITCH PC board ass'y	NASW-8515-1B	1	1B068515-1B	<DD, DC>
EXP	U03	SWITCH PC board ass'y	NASW-8515-1C	1	1B068515-1C	<WT>
EXP	U03	SWITCH PC board ass'y	NASW-8515-1Z	1	1B068515-1Z	<PP>
EXP	U04	HEADPHONE JACK PC board ass'y	NAETC-8516-1B	1	1B068516-1B	<DD, DC>
EXP	U04	HEADPHONE JACK PC board ass'y	NAETC-8516-1C	1	1B068516-1C	<WT>
EXP	U04	HEADPHONE JACK PC board ass'y	NAETC-8516-1Z	1	1B068516-1Z	<PP>

EXP	U05	AMPLIFIER PC board ass'y	NAAF-8523-1B	1	1B068523-1B	<DD, DC>
EXP	U05	AMPLIFIER PC board ass'y	NAAF-8523-1C	1	1B068523-1C	<WT, PP>
EXP	U06	SEC. TERMINAL-2 PC board ass'y	NAPS-8524-1B	1	1B068524-1B	<DD, DC>
EXP	U06	SEC. TERMINAL-2 PC board ass'y	NAPS-8524-1C	1	1B068524-1C	<WT, PP>
EXP	U08	THERMAL SENSOR PC board ass'y	NAETC-8526-1B	1	1B068526-1B	<DD, DC>
EXP	U08	THERMAL SENSOR PC board ass'y	NAETC-8526-1C	1	1B068526-1C	<WT, PP>
EXP	U09	HOLDER PC board ass'y	NAETC-8527-1B	1	1B068527-1B	
EXP	U11	POWER SUPPLY-1 PC board ass'y	NAPS-8544-1B	1	1B068544-1B	<DD, DC>
EXP	U11	POWER SUPPLY-1 PC board ass'y	NAPS-8544-1C	1	1B068544-1C	<WT>
EXP	U11	POWER SUPPLY-1 PC board ass'y	NAPS-8544-1K	1	1B068544-1K	<PP>
EXP	U13	POWER SUPPLY-2 PC board ass'y	NAPS-8546-1B	1	1B068546-1B	<DD, DC>
EXP	U13	POWER SUPPLY-2 PC board ass'y	NAPS-8546-1C	1	1B068546-1C	<WT>
EXP	U13	POWER SUPPLY-2 PC board ass'y	NAPS-8546-1K	1	1B068546-1K	<PP>
EXP	U14	SEC. TERMINAL-1 PC board ass'y	NAPS-8547-1B	1	1B068547-1B	<DD, DC>
EXP	U14	SEC. TERMINAL-1 PC board ass'y	NAPS-8547-1C	1	1B068547-1C	<WT>
EXP	U14	SEC. TERMINAL-1 PC board ass'y	NAPS-8547-1K	1	1B068547-1K	<PP>
EXP	U15	SPEAKER TERMINAL PC board ass'y	NAETC-8548-1B	1	1B068548-1B	<DD, DC>
EXP	U15	SPEAKER TERMINAL PC board ass'y	NAETC-8548-1C	1	1B068548-1C	<WT>
EXP	U15	SPEAKER TERMINAL PC board ass'y	NAETC-8548-1K	1	1B068548-1K	<PP>
EXP	U16	VIDEO PC board ass'y	NAVD-8549-1B	1	1B068549-1B	<DD, DC>
EXP	U16	VIDEO PC board ass'y	NAVD-8549-1C	1	1B068549-1C	<WT>
EXP	U16	VIDEO PC board ass'y	NAVD-8549-1K	1	1B068549-1K	<PP>
EXP	U17	DRIVER AMPLIFIER PC board ass'y	NAAF-8550-1B	1	1B068550-1B	<DD, DC>
EXP	U17	DRIVER AMPLIFIER PC board ass'y	NAAF-8550-1C	1	1B068550-1C	<WT>
EXP	U17	DRIVER AMPLIFIER PC board ass'y	NAAF-8550-1K	1	1B068550-1K	<PP>
EXP	U18	TUNER UNIT	TFCEIU114B	1	240134A	<DD, DC>
EXP	U18	TUNER UNIT	TFCEIE512A	1	240135	<WT, PP>

HT-R330

PC BOARD PARTS LIST

U01	DISPLAY PC BOARD (NADIS-8513-1B/1C/1Z)
U02	DSP PC BOARD (NADG-8514-1B/1C/1Z)
U03	SWITCH PC BOARD (NASW-8515-1B/1C/1Z)
U04	HEADPHONE JACK PC BOARD (NAETC-8516-1B/1C/1Z)

	CIRCUIT NO.	PART NAME	DESCRIPTION	Q'TY	PART NO (SN)	REMARKS
PCB1	U131	PHT CP	GP1FAV51RKF5	1	24120129	
PCB1	U821	REMO SENS	GP1UM281XKVFH=16MM	1	241361	
PCB1	Q111	IC	BU1924FS	1	22242120R2	<PP>
PCB1	Q131	IC	74HCU04F	1	222740046R2	
PCB1	Q151	IC	TC74VHC541FT	1	22274541ER2TO	
PCB1	Q151 or	IC	SN74AHC541PWR	(1)	22274541IR2TI	
PCB1	Q152	IC	TC74HCT7007AF	1	222740077R2TO	
PCB1	Q171	IC	TC7WU04FU	1	22240935R2	
PCB1	Q201	IC	CS494003CQZ	1	22242039R3	
PCB1	Q281	IC	MX26LV040TC	1	W0037R301456M100	
PCB1	Q401	IC	NJM4580M-D	1	22241448R2	
PCB1	Q402	IC	NJM4580M-D	1	22241448R2	
PCB1	Q403	IC	NJM4580M-D	1	22241448R2	
PCB1	Q421	IC	CS42518-CQZR-D	1	22242229R2	
PCB1	Q701	IC	M30622MGP-236FPU0	1	22242250R3	

PCB1	Q721	IC	S-812C56AUA-C3K	1	22242207R2
PCB1	Q802	IC	M66005-0001AHP	1	22242208R3
PCB1	Q703	TR	UNR2213	1	2217140R2
PCB1	Q703 or	TR	RN1404	(1)	2214490R2
PCB1	Q703 or	TR	KRC104S	(1)	2216210R2
PCB1	Q705	TR	UNR2111	1	2217110R2
PCB1	Q705 or	TR	RN2402	(1)	2214530R2
PCB1	Q705 or	TR	KRA102S	(1)	2216220R2
PCB1	Q711	TR	UNR2213	1	2217140R2
PCB1	Q711 or	TR	RN1404	(1)	2214490R2
PCB1	Q711 or	TR	KRC104S	(1)	2216210R2
PCB1	Q712	TR	UNR2111	1	2217110R2
PCB1	Q712 or	TR	RN2402	(1)	2214530R2
PCB1	Q712 or	TR	KRA102S	(1)	2216220R2
PCB1	Q731	TR	UNR2213	1	2217140R2
PCB1	Q731 or	TR	RN1404	(1)	2214490R2
PCB1	Q731 or	TR	KRC104S	(1)	2216210R2
PCB1	Q732	TR	UNR2213	1	2217140R2
PCB1	Q732 or	TR	RN1404	(1)	2214490R2
PCB1	Q732 or	TR	KRC104S	(1)	2216210R2
PCB1	Q801	TUBE PARTS	16BT127GNK	1	213028
PCB1	Q801A	HOLDER	(FL)	1	27191222B
PCB1	Q803	TR	KTC3875-GR	1	2216175R2
PCB1	Q803 or	TR	2SC2712-GR	(1)	2213145R2
PCB1	D101	ZENER D	HZU5.1B	1	224660514R2
PCB1	D101 or	ZENER D	UDZS5.1B	(1)	224550510R2
PCB1	D301	C-DIODE	MA2J111	1	223279R2
PCB1	D301 or	C-DIODE	1SS355	(1)	223269R2
PCB1	D301 or	C-DIODE	1SS352	(1)	223234R2
PCB1	D302	C-DIODE	MA2J111	1	223279R2
PCB1	D302 or	C-DIODE	1SS355	(1)	223269R2
PCB1	D302 or	C-DIODE	1SS352	(1)	223234R2
PCB1	D303	C-DIODE	MA2J111	1	223279R2
PCB1	D303 or	C-DIODE	1SS355	(1)	223269R2
PCB1	D303 or	C-DIODE	1SS352	(1)	223234R2
PCB1	D304	C-DIODE	MA2J111	1	223279R2
PCB1	D304 or	C-DIODE	1SS355	(1)	223269R2
PCB1	D304 or	C-DIODE	1SS352	(1)	223234R2
PCB1	D305	C-DIODE	MA2J111	1	223279R2
PCB1	D305 or	C-DIODE	1SS355	(1)	223269R2
PCB1	D305 or	C-DIODE	1SS352	(1)	223234R2
PCB1	D306	C-DIODE	MA2J111	1	223279R2
PCB1	D306 or	C-DIODE	1SS355	(1)	223269R2
PCB1	D306 or	C-DIODE	1SS352	(1)	223234R2
PCB1	D307	C-DIODE	MA2J111	1	223279R2
PCB1	D307 or	C-DIODE	1SS355	(1)	223269R2
PCB1	D307 or	C-DIODE	1SS352	(1)	223234R2
PCB1	D308	C-DIODE	MA2J111	1	223279R2
PCB1	D308 or	C-DIODE	1SS355	(1)	223269R2
PCB1	D308 or	C-DIODE	1SS352	(1)	223234R2
PCB1	D701	C-DIODE	MA2J111	1	223279R2

PCB1	D701 or	C-DIODE	ISS355	(1)	223269R2	
PCB1	D701 or	C-DIODE	ISS352	(1)	223234R2	
PCB1	D702	C-DIODE	MA2J111	1	223279R2	
PCB1	D702 or	C-DIODE	ISS355	(1)	223269R2	
PCB1	D702 or	C-DIODE	ISS352	(1)	223234R2	
PCB1	D703	C-DIODE	MA2J111	1	223279R2	
PCB1	D703 or	C-DIODE	ISS355	(1)	223269R2	
PCB1	D703 or	C-DIODE	ISS352	(1)	223234R2	
PCB1	D706	C-DIODE	MA2J111	1	223279R2	
PCB1	D706 or	C-DIODE	ISS355	(1)	223269R2	
PCB1	D706 or	C-DIODE	ISS352	(1)	223234R2	
PCB1	D707	ZENER D	HZU5.1B	1	224660514R2	
PCB1	D707 or	ZENER D	UDZS5.1B	(1)	224550510R2	
PCB1	D708	C-DIODE	MA2J111	1	223279R2	
PCB1	D708 or	C-DIODE	ISS355	(1)	223269R2	
PCB1	D708 or	C-DIODE	ISS352	(1)	223234R2	
PCB1	D711	C-DIODE	MA2J111	1	223279R2	
PCB1	D711 or	C-DIODE	ISS355	(1)	223269R2	
PCB1	D711 or	C-DIODE	ISS352	(1)	223234R2	
PCB1	D811	ZENER D	HZU7.5B	1	224660754R2	
PCB1	D811 or	ZENER D	UDZS7.5B	(1)	224550750R2	
PCB1	D821	LED	SLI-343URC-TE7	1	225449	
PCB1	X111	XTL	AF6146CG	1	3010203	<PP>
PCB1	X171	CRYSTAL	HC-49U0312.288MHz	1	3010414	
PCB1	X171A	TAPE	TAPE(CLOTH-8U)	(1)	29110082	
PCB1	X701	CERA LOCK	CSTCR6M0055-R0	1	3010397R2	
PCB1	L111	CHOKE COIL	NCH-1471	1	231237K022R2	<PP>
PCB1	L111 or	CHOKE COIL	NCH-1587-022M	(1)	233533M022R2	<PP>
PCB1	L131	CHOKE COIL	NCH-1587-022M	1	233533M022R2	
PCB1	L133	CHOKE COIL	NCH-1587-022M	1	233533M022R2	
PCB1	L134	CHOKE COIL	NCH-1587-022M	1	233533M022R2	
PCB1	L171	CHOKE COIL	NCH-1471	1	231237K022R2	
PCB1	L171 or	CHOKE COIL	NCH-1587-022M	(1)	233533M022R2	
PCB1	L172	EMIFIL	BK1608LM182-T	1	230958R1	
PCB1	L173	EMIFIL	BK1608LM182-T	1	230958R1	
PCB1	L201	CHOKE COIL	NCH-1471	1	231237K022R2	
PCB1	L202	CHOKE COIL	NCH-1471	1	231237K022R2	
PCB1	L203	CHOKE COIL	NCH-1471	1	231237K022R2	
PCB1	L281	CHOKE COIL	NCH-1471	1	231237K022R2	
PCB1	L301	CHOKE COIL	NCH-1471	1	231237K022R2	
PCB1	L302	CHOKE COIL	NCH-1587-022M	1	233533M022R2	
PCB1	L303	CHOKE COIL	NCH-1587-022M	1	233533M022R2	
PCB1	L311	EMIFIL	BK1608LM182-T	1	230958R1	
PCB1	L312	EMIFIL	BK1608LM182-T	1	230958R1	
PCB1	L313	EMIFIL	BK1608LM182-T	1	230958R1	
PCB1	L701	CHOKE COIL	NCH-1479	1	231237K470R2	
PCB1	L811	CHOKE COIL	NCH-1471	1	231237K022R2	
PCB1	L811 or	CHOKE COIL	NCH-1587-022M	(1)	233533M022R2	
PCB1	L812	CHOKE COIL	NCH-1471	1	231237K022R2	
PCB1	L812 or	CHOKE COIL	NCH-1587-022M	(1)	233533M022R2	
PCB1	L891	CHOKE COIL	NCH-1587-022M	1	233533M022R2	

PCB1	L892	CHOKE COIL	NCH-1587-022M	1	233533M022R2	
PCB1	L893	CHOKE COIL	NCH-1587-022M	1	233533M022R2	
PCB1	C101	VR C	CE04W16V-100M(VR)	1	394641017	
PCB1	C102	C-CERA C	CC725CH1H-101J1	1	342101014R1	
PCB1	C103	C-CERA C	CC725CH1H-101J1	1	342101014R1	
PCB1	C104	VR C	CE04W50V-3.3M(VR)	1	394680337	
PCB1	C105	VR C	CE04W50V-3.3M(VR)	1	394680337	
PCB1	C111	VR C	CE04W16V-100M(VR)	1	394641017	<PP>
PCB1	C113	C-CERA C	CK725F1E-104Z1	1	332161040R1	<PP>
PCB1	C114	VR C	CE04W50V-2.2M(VR)	1	394680227	<PP>
PCB1	C115	C-CERA C	CC725CH1H-561J1	1	342105614R1	<PP>
PCB1	C116	C-CERA C	CC725CH1H-330J1	1	342103304R1	<PP>
PCB1	C117	C-CERA C	CC725CH1H-330J1	1	342103304R1	<PP>
PCB1	C131	C-CERA C	CC725CH1H-101J1	1	342101014R1	
PCB1	C132	C-CERA C	CK725B1C-104K1	1	332121045R1	
PCB1	C133	C-CERA C	CC725CH1H-080D1	1	342100802R1	
PCB1	C139	VR C	CE04W16V-100M(VR)	1	394641017	
PCB1	C140	C-CERA C	CK725F1E-104Z1	1	332161040R1	
PCB1	C141	C-CERA C	CK725F1E-104Z1	1	332161040R1	
PCB1	C145	VR C	CE04W16V-100M(VR)	1	394641017	
PCB1	C146	C-CERA C	CK725F1E-104Z1	1	332161040R1	
PCB1	C151	C-CERA C	CK725F1E-104Z1	1	332161040R1	
PCB1	C152	C-CERA C	CK725F1E-104Z1	1	332161040R1	
PCB1	C171	C-CERA C	CK725F1E-104Z1	1	332161040R1	
PCB1	C172	C-CERA C	CC725CH1H-120J1	1	342101204R1	
PCB1	C173	C-CERA C	CC725CH1H-120J1	1	342101204R1	
PCB1	C201	VR C	CE04W16V-100M(VR)	1	394641017	
PCB1	C202	VR C	CE04W16V-100M(VR)	1	394641017	
PCB1	C203	VR C	CE04W16V-100M(VR)	1	394641017	
PCB1	C204	CHIP TANTAL	CS772SB1C-2.2M	1	395640227R2	
PCB1	C205	C SERA C	CC725CH1H-122J1	1	342101224R1	
PCB1	C206	C-CERA C	CC725CH1H-680J1	1	342106804R1	
PCB1	C207	C-CERA C	CK725F1E-104Z1	1	332161040R1	
PCB1	C208	C-CERA C	CK725F1E-104Z1	1	332161040R1	
PCB1	C209	C-CERA C	CK725F1E-104Z1	1	332161040R1	
PCB1	C210	C-CERA C	CK725F1E-104Z1	1	332161040R1	
PCB1	C212	C-CERA C	CK725F1E-104Z1	1	332161040R1	
PCB1	C213	C-CERA C	CK725F1E-104Z1	1	332161040R1	
PCB1	C214	C-CERA C	CK725F1E-104Z1	1	332161040R1	
PCB1	C215	C-CERA C	CK725F1E-104Z1	1	332161040R1	
PCB1	C216	C-CERA C	CK725F1E-104Z1	1	332161040R1	
PCB1	C217	C-CERA C	CK725F1E-104Z1	1	332161040R1	
PCB1	C219	C-CERA C	CC725CH1H-101J1	1	342101014R1	
PCB1	C281	VR C	CE04W16V-100M(VR)	1	394641017	
PCB1	C282	C-CERA C	CK725F1E-104Z1	1	332161040R1	
PCB1	C301	VR C	CE04W6.3V-220M(VR)	1	394622217	
PCB1	C302	C-CERA C	CK725F1E-104Z1	1	332161040R1	
PCB1	C304	VX C	CE04W50V-47M(VX)	1	393384707	
PCB1	C305	C-CERA C	CK725F1E-104Z1	1	332161040R1	
PCB1	C306	VR C	CE04W16V-100M(VR)	1	394641017	
PCB1	C307	C-CERA C	CK725F1E-104Z1	1	332161040R1	

PCB1	C308	VR C	CE04W6.3V-220M(VR)	1	394622217
PCB1	C309	C-CERA C	CK725B1H-222K1	1	332102225R1
PCB1	C310	C-CERA C	CK725B1H-473K1	1	332104735R1
PCB1	C311	C-CERA C	CK725F1E-104Z1	1	332161040R1
PCB1	C312	VR C	CE04W6.3V-220M(VR)	1	394622217
PCB1	C313	C-CERA C	CK725F1E-104Z1	1	332161040R1
PCB1	C321	VX C	CE04W50V-10M(VX)	1	393381007
PCB1	C322	VX C	CE04W50V-10M(VX)	1	393381007
PCB1	C323	VX C	CE04W50V-10M(VX)	1	393381007
PCB1	C324	VX C	CE04W50V-10M(VX)	1	393381007
PCB1	C325	TF C	ECQ-B50V-222J	1	374722224
PCB1	C326	TF C	ECQ-B50V-222J	1	374722224
PCB1	C331	C-CERA C	CC725CH1H-330J1	1	342103304R1
PCB1	C332	C-CERA C	CC725CH1H-330J1	1	342103304R1
PCB1	C401	TF C	ECQ-B50V-472J	1	374724724
PCB1	C402	TF C	ECQ-B50V-472J	1	374724724
PCB1	C403	TF C	ECQ-B50V-472J	1	374724724
PCB1	C404	TF C	ECQ-V50V-333J	1	374723334
PCB1	C405	TF C	ECQ-B50V-472J	1	374724724
PCB1	C406	TF C	ECQ-B50V-472J	1	374724724
PCB1	C411	C-CERA C	CC725CH1H-681J1	1	342106814R1
PCB1	C412	C-CERA C	CC725CH1H-681J1	1	342106814R1
PCB1	C413	C-CERA C	CC725CH1H-681J1	1	342106814R1
PCB1	C415	C-CERA C	CC725CH1H-681J1	1	342106814R1
PCB1	C416	C-CERA C	CC725CH1H-681J1	1	342106814R1
PCB1	C419	TF C	ECQ-B50V-153J	1	374721534
PCB1	C420	TF C	ECQ-B50V-153J	1	374721534
PCB1	C421	C-CERA C	CC725CH1H-681J1	1	342106814R1
PCB1	C422	C-CERA C	CC725CH1H-681J1	1	342106814R1
PCB1	C423	C-CERA C	CC725CH1H-681J1	1	342106814R1
PCB1	C425	C-CERA C	CC725CH1H-681J1	1	342106814R1
PCB1	C426	C-CERA C	CC725CH1H-681J1	1	342106814R1
PCB1	C523	VX C	CE04W50V-10M(VX)	1	393381007
PCB1	C524	VX C	CE04W50V-10M(VX)	1	393381007
PCB1	C525	VX C	CE04W50V-10M(VX)	1	393381007
PCB1	C526	VX C	CE04W50V-10M(VX)	1	393381007
PCB1	C531	VR C	CE04W16V-220M(VR)	1	394642217
PCB1	C532	VR C	CE04W16V-220M(VR)	1	394642217
PCB1	C701	VR C	CE04W16V-100M(VR)	1	394641017
PCB1	C702	VR C	CE04W16V-100M(VR)	1	394641017
PCB1	C703	VR C	CE04W16V-100M(VR)	1	394641017
PCB1	C704	EDL C	DX-5R5L224	1	3000079
PCB1	C705	VR C	CE04W16V-100M(VR)	1	394641017
PCB1	C706	VR C	CE04W50V-4.7M(VR)	1	394680477
PCB1	C707	C-CERA C	CK725F1E-104Z1	1	332161040R1
PCB1	C708	C-CERA C	CK725F1E-104Z1	1	332161040R1
PCB1	C709	C-CERA C	CK725F1E-104Z1	1	332161040R1
PCB1	C710	C-CERA C	CK725F1E-104Z1	1	332161040R1
PCB1	C711	C-CERA C	CK725F1E-104Z1	1	332161040R1
PCB1	C712	C-CERA C	CK725F1E-104Z1	1	332161040R1
PCB1	C713	C-CERA C	CK725B1H-102K1	1	332101025R1

PCB1	C714	C-CERA C	CK725B1H-102K1	1	332101025R1	
PCB1	C715	C-CERA C	CK725B1H-102K1	1	332101025R1	
PCB1	C716	C-CERA C	CK725B1H-102K1	1	332101025R1	
PCB1	C717	C-CERA C	CK725B1H-102K1	1	332101025R1	
PCB1	C718	C-CERA C	CK725B1H-102K1	1	332101025R1	
PCB1	C719	C-CERA C	CK725B1H-102K1	1	332101025R1	
PCB1	C720	C-CERA C	CK725B1H-102K1	1	332101025R1	
PCB1	C721	C-CERA C	CK725B1H-102K1	1	332101025R1	
PCB1	C722	C-CERA C	CK725B1H-102K1	1	332101025R1	
PCB1	C723	C-CERA C	CK725F1E-104Z1	1	332161040R1	
PCB1	C724	TF C	ECQ-V50V-124J	1	374721244	
PCB1	C747	VX C	CE04W50V-10M(VX)	1	393381007	
PCB1	C751	C-CERA C	CK732B1C-474K	1	337394745R1	
PCB1	C754	VX C	CE04W50V-10M(VX)	1	393381007	
PCB1	C801	MMT C	MMT50V-474J	1	375524744	
PCB1	C802	ELECT C	CE04W6.3V-100M(S)	1	353721019	
PCB1	C803	C-CERA C	CC725CH1H-101J1	1	342101014R1	
PCB1	C804	C-CERA C	CK725F1E-104Z1	1	332161040R1	
PCB1	C805	C-CERA C	CK725F1E-104Z1	1	332161040R1	
PCB1	C806	C-CERA C	CC725CH1H-101J1	1	342101014R1	
PCB1	C807	C-CERA C	CC725CH1H-101J1	1	342101014R1	
PCB1	C808	C-CERA C	CC725CH1H-101J1	1	342101014R1	
PCB1	C809	C-CERA C	CC725CH1H-101J1	1	342101014R1	
PCB1	C811	C-CERA C	CK725F1H-473Z1	1	332154730R1	
PCB1	C812	C-CERA C	CK725F1E-104Z1	1	332161040R1	
PCB1	C813	C-CERA C	CK725F1E-104Z1	1	332161040R1	
PCB1	C814	C-CERA C	CK725F1E-104Z1	1	332161040R1	
PCB1	C815	C-CERA C	CK725F1H-473Z1	1	332154730R1	
PCB1	C816	C-CERA C	CK725F1H-473Z1	1	332154730R1	
PCB1	C817	ELECT C	CE04W50V-33M	1	355783309	
PCB1	C818	C-CERA C	CK725F1H-473Z1	1	332154730R1	
PCB1	C819	C-CERA C	CK725F1E-104Z1	1	332161040R1	
PCB1	C820	C-CERA C	CK725F1E-104Z1	1	332161040R1	
PCB1	C821	C-CERA C	CK725F1E-104Z1	1	332161040R1	
PCB1	C822	C-CERA C	CK725F1E-104Z1	1	332161040R1	
PCB1	C823	ELECT C	CE04W6.3V-100M(S)	1	353721019	
PCB1	C825	C-CERA C	CK725B1H-102K1	1	332101025R1	
PCB1	C891	C-CERA C	CK725B1H-102K1	1	332101025R1	
PCB1	C892	C-CERA C	CK725B1H-102K1	1	332101025R1	
PCB1	C893	C-CERA C	CK725B1H-102K1	1	332101025R1	
PCB1	C894	C-CERA C	CK725B1H-102K1	1	332101025R1	
PCB1	C896	TF C	ECQ-V50V-124J	1	374721244	
PCB1	R101	C-CARBON R	RN72K1J-561JE	1	435035614R1	
PCB1	R102	C-CARBON R	RN72K1J-104JE	1	435031044R1	
PCB1	R103	C-CARBON R	RN72K1J-473JE	1	435034734R1	
PCB1	R104	C-CARBON R	RN72K1J-473JE	1	435034734R1	
PCB1	R105	C-CARBON R	RN72K1J-473JE	1	435034734R1	
PCB1	R106	C-CARBON R	RN72K1J-223JE	1	435032234R1	
PCB1	R107	C-CARBON R	RN72K1J-473JE	1	435034734R1	
PCB1	R111	C-CARBON R	RN72K1J-000JE	1	435030004R1	<DD, DC>
PCB1	R111	C-CARBON R	RN72K1J-000JE	1	435030004R1	<WT>

PCB1	R111	C-CARBON R	RN72K1J-224JE	1	435032244R1	<PP>
PCB1	R112	C-CARBON R	RN72K1J-000JE	1	435030004R1	<DD, DC>
PCB1	R112	C-CARBON R	RN72K1J-000JE	1	435030004R1	<WT>
PCB1	R112	C-CARBON R	RN72K1J-224JE	1	435032244R1	<PP>
PCB1	R113	C-CARBON R	RN72K1J-000JE	1	435030004R1	<DD, DC>
PCB1	R113	C-CARBON R	RN72K1J-000JE	1	435030004R1	<WT>
PCB1	R113	C-CARBON R	RN72K1J-224JE	1	435032244R1	<PP>
PCB1	R114	C-CARBON R	RN72K1J-102JE	1	435031024R1	<PP>
PCB1	R131	C-CARBON R	RN72K1J-750JE	1	435037504R1	
PCB1	R132	C-CARBON R	RN72K1J-221JE	1	435032214R1	
PCB1	R133	C-CARBON R	RN72K1J-224JE	1	435032244R1	
PCB1	R134	C-CARBON R	RN72K1J-103JE	1	435031034R1	
PCB1	R137	C-CARBON R	RN72K1J-224JE	1	435032244R1	
PCB1	R139	C-CARBON R	RN72K1J-224JE	1	435032244R1	
PCB1	R141	C-CARBON R	RN72K1J-221JE	1	435032214R1	
PCB1	R161	C-CARBON R	RN72K1J-221JE	1	435032214R1	
PCB1	R162	C-CARBON R	RN72K1J-221JE	1	435032214R1	
PCB1	R163	C-CARBON R	RN72K1J-221JE	1	435032214R1	
PCB1	R164	C-CARBON R	RN72K1J-221JE	1	435032214R1	
PCB1	R165	C-CARBON R	RN72K1J-221JE	1	435032214R1	
PCB1	R166	C-CARBON R	RN72K1J-332JE	1	435033324R1	
PCB1	R171	C-CARBON R	RN72K1J-105JE	1	435031054R1	
PCB1	R201	C-CARBON R	RN72K1J-332JE	1	435033324R1	
PCB1	R202	C-CARBON R	RN72K1J-332JE	1	435033324R1	
PCB1	R203	C-CARBON R	RN72K1J-332JE	1	435033324R1	
PCB1	R205	C-CARBON R	RN72K1J-103JE	1	435031034R1	
PCB1	R208	C-CARBON R	RN72K1J-103JE	1	435031034R1	
PCB1	R209	C-CARBON R	RN72K1J-103JE	1	435031034R1	
PCB1	R210	C-CARBON R	RN72K1J-332JE	1	435033324R1	
PCB1	R211	C-CARBON R	RN72K1J-332JE	1	435033324R1	
PCB1	R212	C-CARBON R	RN72K1J-103JE	1	435031034R1	
PCB1	R215	C-CARBON R	RN72K1J-332JE	1	435033324R1	
PCB1	R216	C-CARBON R	RN72K1J-103JE	1	435031034R1	
PCB1	R217	C-CARBON R	RN72K1J-103JE	1	435031034R1	
PCB1	R218	C-CARBON R	RN72K1J-103JE	1	435031034R1	
PCB1	R219	C-CARBON R	RN72K1J-103JE	1	435031034R1	
PCB1	R220	C-CARBON R	RN72K1J-103JE	1	435031034R1	
PCB1	R221	C-CARBON R	RN72K1J-103JE	1	435031034R1	
PCB1	R222	C-CARBON R	RN72K1J-103JE	1	435031034R1	
PCB1	R223	C-CARBON R	RN72K1J-103JE	1	435031034R1	
PCB1	R224	C-CARBON R	RN72K1J-103JE	1	435031034R1	
PCB1	R225	C-CARBON R	RN72K1J-103JE	1	435031034R1	
PCB1	R234	C-CARBON R	RN72K1J-103JE	1	435031034R1	
PCB1	R235	C-CARBON R	RN72K1J-103JE	1	435031034R1	
PCB1	R236	C-CARBON R	RN72K1J-103JE	1	435031034R1	
PCB1	R238	C-CARBON R	RN72K1J-470JE	1	435034704R1	
PCB1	R239	C-CARBON R	RN72K1J-103JE	1	435031034R1	
PCB1	R240	C-CARBON R	RN72K1J-103JE	1	435031034R1	
PCB1	R242	C-CARBON R	RN72K1J-103JE	1	435031034R1	
PCB1	R249	C-CARBON R	RN72K1J-103JE	1	435031034R1	
PCB1	R250	C-CARBON R	RN72K1J-103JE	1	435031034R1	

PCB1	R251	C-CARBON R	RN72K1J-103JE	1	435031034R1
PCB1	R255	C-CARBON R	RN72K1J-103JE	1	435031034R1
PCB1	R256	C-CARBON R	RN72K1J-103JE	1	435031034R1
PCB1	R257	C-CARBON R	RN72K1J-331JE	1	435033314R1
PCB1	R258	C-CARBON R	RN72K1J-272JE	1	435032724R1
PCB1	R259	C-CARBON R	RN72K1J-470JE	1	435034704R1
PCB1	R260	C-CARBON R	RN72K1J-103JE	1	435031034R1
PCB1	R261	C-CARBON R	RN72K1J-103JE	1	435031034R1
PCB1	R266	C-CARBON R	RN72K1J-103JE	1	435031034R1
PCB1	R269	C-CARBON R	RN72K1J-332JE	1	435033324R1
PCB1	R270	C-CARBON R	RN72K1J-221JE	1	435032214R1
PCB1	R271	C-CARBON R	RN72K1J-103JE	1	435031034R1
PCB1	R272	C-CARBON R	RN72K1J-103JE	1	435031034R1
PCB1	R273	C-CARBON R	RN72K1J-103JE	1	435031034R1
PCB1	R274	C-CARBON R	RN72K1J-103JE	1	435031034R1
PCB1	R275	C-CARBON R	RN72K1J-103JE	1	435031034R1
PCB1	R276	C-CARBON R	RN72K1J-103JE	1	435031034R1
PCB1	R277	C-CARBON R	RN72K1J-103JE	1	435031034R1
PCB1	R301	C-CARBON R	RN72K1J-470JE	1	435034704R1
PCB1	R302	C-CARBON R	RN72K1J-470JE	1	435034704R1
PCB1	R303	C-CARBON R	RN72K1J-470JE	1	435034704R1
PCB1	R304	C-CARBON R	RN72K1J-221JE	1	435032214R1
PCB1	R305	C-CARBON R	RN72K1J-221JE	1	435032214R1
PCB1	R306	C-CARBON R	RN72K1J-221JE	1	435032214R1
PCB1	R307	C-CARBON R	RN72K1J-221JE	1	435032214R1
PCB1	R308	C-CARBON R	RN72K1J-221JE	1	435032214R1
PCB1	R309	C-CARBON R	RN72K1J-221JE	1	435032214R1
PCB1	R311	C-CARBON R	RN72K1J-272JE	1	435032724R1
PCB1	R312	C-CARBON R	RN72K1J-470JE	1	435034704R1
PCB1	R313	C-CARBON R	RN72K1J-470JE	1	435034704R1
PCB1	R314	C-CARBON R	RN72K1J-470JE	1	435034704R1
PCB1	R315	C-CARBON R	RN72K1J-470JE	1	435034704R1
PCB1	R316	C-CARBON R	RN72K1J-470JE	1	435034704R1
PCB1	R317	C-CARBON R	RN72K1J-470JE	1	435034704R1
PCB1	R318	C-CARBON R	RN72K1J-470JE	1	435034704R1
PCB1	R319	C-CARBON R	RN72K1J-470JE	1	435034704R1
PCB1	R321	C-CARBON R	RN72K1J-560JE	1	435035604R1
PCB1	R322	C-CARBON R	RN72K1J-560JE	1	435035604R1
PCB1	R323	C-CARBON R	RN72K1J-560JE	1	435035604R1
PCB1	R324	C-CARBON R	RN72K1J-560JE	1	435035604R1
PCB1	R325	C-CARBON R	RN72K1J-392JE	1	435033924R1
PCB1	R326	C-CARBON R	RN72K1J-392JE	1	435033924R1
PCB1	R332	C-CARBON R	RN72K1J-331JE	1	435033314R1
PCB1	R333	C-CARBON R	RN72K1J-331JE	1	435033314R1
PCB1	R338	C-CARBON R	RN72K1J-000JE	1	435030004R1
PCB1	R339	C-CARBON R	RN72K1J-000JE	1	435030004R1
PCB1	R340	C-CARBON R	RN72K1J-000JE	1	435030004R1
PCB1	R341	C-CARBON R	RN72K1J-000JE	1	435030004R1
PCB1	R401	C-CARBON R	RN72K1J-332JE	1	435033324R1
PCB1	R402	C-CARBON R	RN72K1J-332JE	1	435033324R1
PCB1	R403	C-CARBON R	RN72K1J-332JE	1	435033324R1

PCB1	R601	C-CARBON R	RN72K1J-102JE	1	435031024R1	
PCB1	R602	C-CARBON R	RN72K1J-103JE	1	435031034R1	
PCB1	R603	C-CARBON R	RN72K1J-000JE	1	435030004R1	
PCB1	R604	C-CARBON R	RN72K1J-105JE	1	435031054R1	
PCB1	R605	C-CARBON R	RN72K1J-000JE	1	435030004R1	
PCB1	R612	C-CARBON R	RN72K1J-473JE	1	435034734R1	
PCB1	R618	C-CARBON R	RN72K1J-103JE	1	435031034R1	
PCB1	R621	C-CARBON R	RN72K1J-103JE	1	435031034R1	
PCB1	R622	C-CARBON R	RN72K1J-103JE	1	435031034R1	
PCB1	R624	C-CARBON R	RN72K1J-103JE	1	435031034R1	
PCB1	R629	C-CARBON R	RN72K1J-103JE	1	435031034R1	
PCB1	R630	C-CARBON R	RN72K1J-103JE	1	435031034R1	
PCB1	R631	C-CARBON R	RN72K1J-103JE	1	435031034R1	
PCB1	R632	C-CARBON R	RN72K1J-103JE	1	435031034R1	
PCB1	R636	C-CARBON R	RN72K1J-103JE	1	435031034R1	
PCB1	R639	C-CARBON R	RN72K1J-103JE	1	435031034R1	
PCB1	R640	C-CARBON R	RN72K1J-103JE	1	435031034R1	
PCB1	R641	C-CARBON R	RN72K1J-103JE	1	435031034R1	
PCB1	R642	C-CARBON R	RN72K1J-103JE	1	435031034R1	
PCB1	R646	C-CARBON R	RN72K1J-103JE	1	435031034R1	
PCB1	R647	C-CARBON R	RN72K1J-102JE	1	435031024R1	
PCB1	R661	C-CARBON R	RN72K1J-223JE	1	435032234R1	
PCB1	R663	C-CARBON R	RN72K1J-223JE	1	435032234R1	
PCB1	R673	C-CARBON R	RN72K1J-224JE	1	435032244R1	
PCB1	R674	C-CARBON R	RN72K1J-000JE	1	435030004R1	
PCB1	R681	C-CARBON R	RN72K1J-103JE	1	435031034R1	
PCB1	R683	C-CARBON R	RN72K1J-000JE	1	435030004R1	
PCB1	R686	C-CARBON R	RN72K1J-333JE	1	435033334R1	
PCB1	R687	C-CARBON R	RN72K1J-333JE	1	435033334R1	
PCB1	R688	C-CARBON R	RN72K1J-103JE	1	435031034R1	<WT>
PCB1	R688	C-CARBON R	RN72K1J-563JE	1	435035634R1	<PP>
PCB1	R693	C-CARBON R	RN72K1J-272JE	1	435032724R1	
PCB1	R694	C-CARBON R	RN72K1J-272JE	1	435032724R1	
PCB1	R695	C-CARBON R	RN72K1J-272JE	1	435032724R1	
PCB1	R696	C-CARBON R	RN72K1J-272JE	1	435032724R1	
PCB1	R698	C-CARBON R	RN72K1J-000JE	1	435030004R1	
PCB1	R708	C-CARBON R	RN72K1J-103JE	1	435031034R1	
PCB1	R709	C-CARBON R	RN72K1J-221JE	1	435032214R1	
PCB1	R710	C-CARBON R	RN72K1J-221JE	1	435032214R1	
PCB1	R717	C-CARBON R	RN72K1J-103JE	1	435031034R1	
PCB1	R719	C-CARBON R	RN72K1J-221JE	1	435032214R1	
PCB1	R729	C-CARBON R	RN72K1J-100JE	1	435031004R1	
PCB1	R730	C-CARBON R	RN72K1J-100JE	1	435031004R1	
PCB1	R731	C-CARBON R	RN72K1J-221JE	1	435032214R1	
PCB1	R732	C-CARBON R	RN72K1J-221JE	1	435032214R1	
PCB1	R733	C-CARBON R	RN72K1J-221JE	1	435032214R1	
PCB1	R734	C-CARBON R	RN72K1J-221JE	1	435032214R1	
PCB1	R736	C-CARBON R	RN72K1J-221JE	1	435032214R1	
PCB1	R747	C-CARBON R	RN72K1J-222JE	1	435032224R1	
PCB1	R758	C-CARBON R	RN72K1J-221JE	1	435032214R1	
PCB1	R759	C-CARBON R	RN72K1J-221JE	1	435032214R1	

PCB1	R763	C-CARBON R	RN72K1J-102JE	1	435031024R1	
PCB1	R765	C-CARBON R	RN72K1J-102JE	1	435031024R1	
PCB1	R766	C-CARBON R	RN72K1J-102JE	1	435031024R1	
PCB1	R767	C-CARBON R	RN72K1J-102JE	1	435031024R1	
PCB1	R770	C-CARBON R	RN72K1J-473JE	1	435034734R1	
PCB1	R771	C-CARBON R	RN72K1J-102JE	1	435031024R1	
PCB1	R772	C-CARBON R	RN72K1J-102JE	1	435031024R1	
PCB1	R773	C-CARBON R	RN72K1J-331JE	1	435033314R1	
PCB1	R775	C-CARBON R	RN72K1J-102JE	1	435031024R1	
PCB1	R781	C-CARBON R	RN72K1J-102JE	1	435031024R1	
PCB1	R783	C-CARBON R	RN72K1J-102JE	1	435031024R1	
PCB1	R784	C-CARBON R	RN72K1J-102JE	1	435031024R1	
PCB1	R785	C-CARBON R	RN72K1J-000JE	1	435030004R1	
PCB1	R786	C-CARBON R	RN72K1J-103JE	1	435031034R1	
PCB1	R787	C-CARBON R	RN72K1J-563JE	1	435035634R1	
PCB1	R788	C-CARBON R	RN72K1J-000JE	1	435030004R1	<DD, DC>
PCB1	R788	C-CARBON R	RN72K1J-103JE	1	435031034R1	<WT>
PCB1	R788	C-CARBON R	RN72K1J-333JE	1	435033334R1	<PP>
PCB1	R789	C-CARBON R	RN72K1J-472JE	1	435034724R1	
PCB1	R790	C-CARBON R	RN72K1J-472JE	1	435034724R1	
PCB1	R791	C-CARBON R	RN72K1J-472JE	1	435034724R1	
PCB1	R792	C-CARBON R	RN72K1J-472JE	1	435034724R1	
PCB1	R793	C-CARBON R	RN72K1J-472JE	1	435034724R1	
PCB1	R794	C-CARBON R	RN72K1J-472JE	1	435034724R1	
PCB1	R795	C-CARBON R	RN72K1J-472JE	1	435034724R1	
PCB1	R797	C-CARBON R	RN72K1J-472JE	1	435034724R1	
PCB1	R800	C-CARBON R	RN72K1J-221JE	1	435032214R1	
PCB1	R801	C-CARBON R	RN72K1J-273JE	1	435032734R1	
PCB1	R802	C-CARBON R	RN72K1J-332JE	1	435033324R1	
PCB1	R803	C-CARBON R	RN72K1J-332JE	1	435033324R1	
PCB1	R804	C-CARBON R	RN72K1J-221JE	1	435032214R1	
PCB1	R805	C-CARBON R	RN72K1J-221JE	1	435032214R1	
PCB1	R806	C-CARBON R	RN72K1J-221JE	1	435032214R1	
PCB1	R807	C-CARBON R	RN72K1J-221JE	1	435032214R1	
PCB1	R808	C-CARBON R	RN72K1J-104JE	1	435031044R1	
PCB1	R810	C-CARBON R	RN72K1J-101JE	1	435031014R1	
PCB1	R811	C-CARBON R	RN72K1J-103JE	1	435031034R1	
PCB1	R812	C-CARBON R	RN72K1J-103JE	1	435031034R1	
PCB1	R813	C-CARBON R	RN72K1J-103JE	1	435031034R1	
PCB1	R814	C-CARBON R	RN72K1J-103JE	1	435031034R1	
PCB1	R821	C-CARBON R	RN72K1J-222JE	1	435032224R1	
PCB1	R827	C-CARBON R	RN72K1J-101JE	1	435031014R1	
PCB1	R828	C-CARBON R	RN72K1J-102JE	1	435031024R1	
PCB1	R831	C-CARBON R	RN72K1J-331JE	1	435033314R1	
PCB1	R832	C-CARBON R	RN72K1J-471JE	1	435034714R1	
PCB1	R833	C-CARBON R	RN72K1J-561JE	1	435035614R1	
PCB1	R834	C-CARBON R	RN72K1J-821JE	1	435038214R1	
PCB1	R835	C-CARBON R	RN72K1J-122JE	1	435031224R1	
PCB1	R836	C-CARBON R	RN72K1J-222JE	1	435032224R1	
PCB1	R841	C-CARBON R	RN72K1J-331JE	1	435033314R1	
PCB1	R842	C-CARBON R	RN72K1J-471JE	1	435034714R1	

PCB1	R843	C-CARBON R	RN72K1J-561JE	1	435035614R1
PCB1	R844	C-CARBON R	RN72K1J-821JE	1	435038214R1
PCB1	R845	C-CARBON R	RN72K1J-122JE	1	435031224R1
PCB1	R846	C-CARBON R	RN72K1J-222JE	1	435032224R1
PCB1	R847	C-CARBON R	RN72K1J-392JE	1	435033924R1
PCB1	R851	C-CARBON R	RN72K1J-331JE	1	435033314R1
PCB1	R852	C-CARBON R	RN72K1J-471JE	1	435034714R1
PCB1	R853	C-CARBON R	RN72K1J-561JE	1	435035614R1
PCB1	R854	C-CARBON R	RN72K1J-821JE	1	435038214R1
PCB1	R855	C-CARBON R	RN72K1J-122JE	1	435031224R1
PCB1	R856	C-CARBON R	RN72K1J-222JE	1	435032224R1
PCB1	R857	C-CARBON R	RN72K1J-392JE	1	435033924R1
PCB1	R858	C-CARBON R	RN72K1J-123JE	1	435031234R1
PCB1	R861	C-CARBON R	RN72K1J-331JE	1	435033314R1
PCB1	R862	C-CARBON R	RN72K1J-471JE	1	435034714R1
PCB1	R863	C-CARBON R	RN72K1J-561JE	1	435035614R1
PCB1	R864	C-CARBON R	RN72K1J-821JE	1	435038214R1
PCB1	R865	C-CARBON R	RN72K1J-122JE	1	435031224R1
PCB1	R866	C-CARBON R	RN72K1J-222JE	1	435032224R1
PCB1	R867	C-CARBON R	RN72K1J-392JE	1	435033924R1
PCB1	R868	C-CARBON R	RN72K1J-123JE	1	435031234R1
PCB1	S801	PUSH SW	NPS-111-S681	1	25035718
PCB1	S801 or	PUSH SW	NPS-111-S677	(1)	25035714
PCB1	S807	PUSH SW	NPS-111-S681	1	25035718
PCB1	S807 or	PUSH SW	NPS-111-S677	(1)	25035714
PCB1	S808	PUSH SW	NPS-111-S681	1	25035718
PCB1	S808 or	PUSH SW	NPS-111-S677	(1)	25035714
PCB1	S809	PUSH SW	NPS-111-S681	1	25035718
PCB1	S809 or	PUSH SW	NPS-111-S677	(1)	25035714
PCB1	S811	PUSH SW	NPS-111-S681	1	25035718
PCB1	S811 or	PUSH SW	NPS-111-S677	(1)	25035714
PCB1	S812	PUSH SW	NPS-111-S681	1	25035718
PCB1	S812 or	PUSH SW	NPS-111-S677	(1)	25035714
PCB1	S813	PUSH SW	NPS-111-S681	1	25035718
PCB1	S813 or	PUSH SW	NPS-111-S677	(1)	25035714
PCB1	S815	PUSH SW	NPS-111-S681	1	25035718
PCB1	S815 or	PUSH SW	NPS-111-S677	(1)	25035714
PCB1	S816	PUSH SW	NPS-111-S681	1	25035718
PCB1	S816 or	PUSH SW	NPS-111-S677	(1)	25035714
PCB1	S817	PUSH SW	NPS-111-S681	1	25035718
PCB1	S817 or	PUSH SW	NPS-111-S677	(1)	25035714
PCB1	S818	PUSH SW	NPS-111-S681	1	25035718
PCB1	S818 or	PUSH SW	NPS-111-S677	(1)	25035714
PCB1	S821	PUSH SW	NPS-111-S681	1	25035718
PCB1	S821 or	PUSH SW	NPS-111-S677	(1)	25035714
PCB1	S822	PUSH SW	NPS-111-S681	1	25035718
PCB1	S822 or	PUSH SW	NPS-111-S677	(1)	25035714
PCB1	S823	PUSH SW	NPS-111-S681	1	25035718
PCB1	S823 or	PUSH SW	NPS-111-S677	(1)	25035714
PCB1	S824	PUSH SW	NPS-111-S681	1	25035718
PCB1	S824 or	PUSH SW	NPS-111-S677	(1)	25035714

PCB1	S825	PUSH SW	NPS-111-S681	1	25035718	
PCB1	S825 or	PUSH SW	NPS-111-S677	(1)	25035714	
PCB1	S826	PUSH SW	NPS-111-S681	1	25035718	
PCB1	S826 or	PUSH SW	NPS-111-S677	(1)	25035714	
PCB1	S827	PUSH SW	NPS-111-S681	1	25035718	
PCB1	S827 or	PUSH SW	NPS-111-S677	(1)	25035714	
PCB1	S828	PUSH SW	NPS-111-S681	1	25035718	
PCB1	S828 or	PUSH SW	NPS-111-S677	(1)	25035714	
PCB1	S829	PUSH SW	NPS-111-S681	1	25035718	
PCB1	S829 or	PUSH SW	NPS-111-S677	(1)	25035714	
PCB1	S831	PUSH SW	NPS-111-S681	1	25035718	
PCB1	S831 or	PUSH SW	NPS-111-S677	(1)	25035714	
PCB1	S832	PUSH SW	NPS-111-S681	1	25035718	
PCB1	S832 or	PUSH SW	NPS-111-S677	(1)	25035714	
PCB1	S833	PUSH SW	NPS-111-S681	1	25035718	
PCB1	S833 or	PUSH SW	NPS-111-S677	(1)	25035714	
PCB1	S834	PUSH SW	NPS-111-S681	1	25035718	
PCB1	S834 or	PUSH SW	NPS-111-S677	(1)	25035714	
PCB1	S835	PUSH SW	NPS-111-S681	1	25035718	
PCB1	S835 or	PUSH SW	NPS-111-S677	(1)	25035714	
PCB1	S836	PUSH SW	NPS-111-S681	1	25035718	
PCB1	S836 or	PUSH SW	NPS-111-S677	(1)	25035714	
PCB1	S837	PUSH SW	NPS-111-S681	1	25035718	
PCB1	S837 or	PUSH SW	NPS-111-S677	(1)	25035714	
PCB1	S838	PUSH SW	NPS-111-S681	1	25035718	
PCB1	S838 or	PUSH SW	NPS-111-S677	(1)	25035714	
PCB1	S839	PUSH SW	NPS-111-S681	1	25035718	
PCB1	S839 or	PUSH SW	NPS-111-S677	(1)	25035714	
PCB1	S851	R ENCODE	EC12E2425	1	25065655	
PCB1	P101A	SOCKET	NSCT-15P2108	1	25052211	
PCB1	P132	PIN JACK	NPJ-1PDBL291	1	25045473	
PCB1	P132 or	PIN JACK	NPJ-1PDO554	(1)	25045772	
PCB1	P301A	SOCKET	NSCT-10P2190	1	25052293	
PCB1	P302A	SOCKET	NSCT-20P2200	1	25052303	
PCB1	P303A	SOCKET	NSCT-20P2200	1	25052303	
PCB1	P311A	SOCKET AS	NSAS-20P1043	1	2002A392025UL	
PCB1	P312	HOLDER	HOLDER(CLAMP)	1	27190540-1	
PCB1	P703A	SOCKET	NSCT-23P2257	1	25052360	
PCB1	P703A or	SOCKET	NSCT-23P2441	(1)	25052544	
PCB1	P703B	SOCKET	NSCT-23P2257	1	25052360	
PCB1	P703B or	SOCKET	NSCT-23P2441	(1)	25052544	
PCB1	P721	ST JACK	LGY2502-0200FC	1	25045696	
PCB1	P891	ST JACK	MSJ-064-05A SR	1	25045783	
PCB1	P891 or	ST JACK	YKB21-5005	(1)	25045724	
PCB1	P2005	PLUG	NPLG-13P0968	1	25056018	
PCB1	E301	TRM	NTM-1P233(M1969)	1	25060302	
PCB1	E301A	ISO PLT	---	1	28175316	
PCB1	E891	RETAINER	KANAGU	1	27141059	
PCB1	JL832A	WIRE HOL	NSCT-3P894	1	25051107	
PCB1	JL832B	WIRE HOL	NSCT-3P894	1	25051107	
PCB1	JL891A	WIRE HOL	NSCT-5P896	1	25051109	

U05	AMPLIFIER PC BOARD (NAAF-8523-1B/1C)
U06	SEC. TERMINAL-2 PC BOARD (NAPS-8524-1B/1C)
U08	THERMAL SENSOR PC BOARD (NAETC-8526-1B/1C)

	CIRCUIT NO.	PART NAME	DESCRIPTION	Q'TY	PART NO (SN)	REMARKS
PCB2	Q5501	IC	NJW1157B	1	22242193R3	
PCB2	Q5502	IC	NJU7311AM	1	22242209R2	
PCB2	Q5503	IC	NJM4580M-D	1	22241448R2	
PCB2	Q5630	IC	NJM4580M-D	1	22241448R2	
PCB2	Q5640	IC	AN34060A	1	22242205	
PCB2	Q5640A	SCREW	3P+10FN(BC)	1	82143010	
PCB2	Q5660	IC(REGURATOR)	7812HF(TA7812S)	1	222780124TOS	
PCB2	Q5660 or	IC(REGULATOR)	78M12HF	(1)	222780125	
PCB2	Q5660A	SCREW	3P+10FN(BC)	1	82143010	
PCB2	Q5661	IC(REGURATOR)	79012HF(TA79012S)	1	222790124TOS	
PCB2	Q5661 or	IC(REGULATOR)	79M12HF	(1)	222790125	
PCB2	Q5661A	SCREW	3P+10FN(BC)	1	82143010	
PCB2	Q5661B	HEAT SINK	RAD-213	1	27160570	
PCB2	Q6380	IC	LM61CIZ	1	22242212	
PCB2	Q5600	TR	RN1441	1	2215410R2	
PCB2	Q5601	TR	RN1441	1	2215410R2	
PCB2	Q5602	TR	RN1441	1	2215410R2	
PCB2	Q5603	TR	RN1441	1	2215410R2	
PCB2	Q5604	TR	RN1441	1	2215410R2	
PCB2	Q5607	TR	RN1441	1	2215410R2	
PCB2	Q5617	TR	RN1441	1	2215410R2	
PCB2	Q6010	TR	2SC1740S-S	1	2213285	
PCB2	Q6011	TR	2SC1740S-S	1	2213285	
PCB2	Q6012	TR	2SC1740S-S	1	2213285	
PCB2	Q6013	TR	2SC1740S-S	1	2213285	
PCB2	Q6014	TR	2SC1740S-S	1	2213285	
PCB2	Q6015	TR	2SC1740S-S	1	2213285	
PCB2	Q6020	TR	2SC1740S-S	1	2213285	
PCB2	Q6021	TR	2SC1740S-S	1	2213285	
PCB2	Q6022	TR	2SC1740S-S	1	2213285	
PCB2	Q6023	TR	2SC1740S-S	1	2213285	
PCB2	Q6024	TR	2SC1740S-S	1	2213285	
PCB2	Q6025	TR	2SC1740S-S	1	2213285	
PCB2	Q6030	TR	2SC5171	1	2203010	
PCB2	Q6030 or	TR	2SC5993-Q,P	(1)	2217161	
PCB2	Q6031	TR	2SC5171	1	2203010	
PCB2	Q6031 or	TR	2SC5993-Q,P	(1)	2217161	
PCB2	Q6032	TR	2SC5171	1	2203010	
PCB2	Q6032 or	TR	2SC5993-Q,P	(1)	2217161	
PCB2	Q6033	TR	2SC5171	1	2203010	
PCB2	Q6033 or	TR	2SC5511-E	(1)	2203845	
PCB2	Q6034	TR	2SC5171	1	2203010	
PCB2	Q6034 or	TR	2SC5511-E	(1)	2203845	
PCB2	Q6035	TR	2SC5171	1	2203010	
PCB2	Q6035 or	TR	2SC5511-E	(1)	2203845	

PCB2	Q6040	TR	2SA1930	1	2203000	
PCB2	Q6040 or	TR	2SA2140-Q,P	(1)	2217151	
PCB2	Q6041	TR	2SA1930	1	2203000	
PCB2	Q6041 or	TR	2SA2140-Q,P	(1)	2217151	
PCB2	Q6042	TR	2SA1930	1	2203000	
PCB2	Q6042 or	TR	2SA2140-Q,P	(1)	2217151	
PCB2	Q6043	TR	2SA1930	1	2203000	
PCB2	Q6043 or	TR	2SA2005-E	(1)	2203835	
PCB2	Q6044	TR	2SA1930	1	2203000	
PCB2	Q6044 or	TR	2SA2005-E	(1)	2203835	
PCB2	Q6045	TR	2SA1930	1	2203000	
PCB2	Q6045 or	TR	2SA2005-E	(1)	2203835	
PCB2	Q6070	TR	2SC2240-BL	1	2211406	
PCB2	Q6070 or	TR	2SC2240-GR	(1)	2211405	
PCB2	Q6071	TR	2SC2240-BL	1	2211406	
PCB2	Q6071 or	TR	2SC2240-GR	(1)	2211405	
PCB2	Q6072	TR	2SC2240-BL	1	2211406	
PCB2	Q6072 or	TR	2SC2240-GR	(1)	2211405	
PCB2	Q6073	TR	2SC2240-BL	1	2211406	
PCB2	Q6073 or	TR	2SC2240-GR	(1)	2211405	
PCB2	Q6074	TR	2SC2240-BL	1	2211406	
PCB2	Q6074 or	TR	2SC2240-GR	(1)	2211405	
PCB2	Q6075	TR	2SC2240-BL	1	2211406	
PCB2	Q6075 or	TR	2SC2240-GR	(1)	2211405	
PCB2	Q6701	TR	2SC2240-BL	1	2211406	
PCB2	Q6701 or	TR	2SC2240-GR	(1)	2211405	
PCB2	Q6701 or	TR	KTC3200-GR	(1)	2215895	
PCB2	Q6701 or	TR	KTC3200-BL	(1)	2215896	
PCB2	Q6702	TR	2SC2240-BL	1	2211406	
PCB2	Q6702 or	TR	2SC2240-GR	(1)	2211405	
PCB2	Q6702 or	TR	KTC3200-GR	(1)	2215895	
PCB2	Q6702 or	TR	KTC3200-BL	(1)	2215896	
PCB2	Q6703	TR	KTA1268-GR	1	2215885	
PCB2	Q6703 or	TR	KTA1268-BL	(1)	2215886	
PCB2	Q6703 or	TR	2SA992-F	(1)	2211792	
PCB2	Q6703 or	TR	2SA992-E	(1)	2211793	
PCB2	Q6703 or	TR	2SA1123-R	(1)	2214974	
PCB2	Q6901	TR	KTC3199-GR	1	2215864	
PCB2	Q6901 or	TR	2SC2458-GR	(1)	2212115	
PCB2	Q6901 or	TR	2SC1740S-R	(1)	2213284	
PCB2	Q6901 or	TR	2SC1740S-S	(1)	2213285	
PCB2	D5671	ZENER D	MTZJ6.8C	1	224470683	
PCB2	D5671 or	ZENER D	DZ-6.8BSC	(1)	224850683	
PCB2	D5672	ZENER D	MTZJ6.8C	1	224470683	
PCB2	D5672 or	ZENER D	DZ-6.8BSC	(1)	224850683	
PCB2	D5710	DIODE	1SS133	1	223163	
PCB2	D5710 or	DIODE	1SS270A	(1)	223205	
PCB2	D5710 or	DIODE	1SS133(DS)	(1)	223280	
PCB2	D5711	DIODE	1SS133	1	223163	
PCB2	D5711 or	DIODE	1SS270A	(1)	223205	
PCB2	D5711 or	DIODE	1SS133(DS)	(1)	223280	

PCB2	D6000	DIODE	ISS133	1	223163	
PCB2	D6000 or	DIODE	ISS270A	(1)	223205	
PCB2	D6000 or	DIODE	ISS133(DS)	(1)	223280	
PCB2	D6001	DIODE	ISS133	1	223163	
PCB2	D6001 or	DIODE	ISS270A	(1)	223205	
PCB2	D6001 or	DIODE	ISS133(DS)	(1)	223280	
PCB2	D6002	DIODE	ISS133	1	223163	
PCB2	D6002 or	DIODE	ISS270A	(1)	223205	
PCB2	D6002 or	DIODE	ISS133(DS)	(1)	223280	
PCB2	D6003	DIODE	ISS133	1	223163	
PCB2	D6003 or	DIODE	ISS270A	(1)	223205	
PCB2	D6003 or	DIODE	ISS133(DS)	(1)	223280	
PCB2	D6004	DIODE	ISS133	1	223163	
PCB2	D6004 or	DIODE	ISS270A	(1)	223205	
PCB2	D6004 or	DIODE	ISS133(DS)	(1)	223280	
PCB2	D6005	DIODE	ISS133	1	223163	
PCB2	D6005 or	DIODE	ISS270A	(1)	223205	
PCB2	D6005 or	DIODE	ISS133(DS)	(1)	223280	
PCB2	D6010	DIODE	ISS133	1	223163	
PCB2	D6010 or	DIODE	ISS270A	(1)	223205	
PCB2	D6010 or	DIODE	ISS133(DS)	(1)	223280	
PCB2	D6011	DIODE	ISS133	1	223163	
PCB2	D6011 or	DIODE	ISS270A	(1)	223205	
PCB2	D6011 or	DIODE	ISS133(DS)	(1)	223280	
PCB2	D6012	DIODE	ISS133	1	223163	
PCB2	D6012 or	DIODE	ISS270A	(1)	223205	
PCB2	D6012 or	DIODE	ISS133(DS)	(1)	223280	
PCB2	D6013	DIODE	ISS133	1	223163	
PCB2	D6013 or	DIODE	ISS270A	(1)	223205	
PCB2	D6013 or	DIODE	ISS133(DS)	(1)	223280	
PCB2	D6014	DIODE	ISS133	1	223163	
PCB2	D6014 or	DIODE	ISS270A	(1)	223205	
PCB2	D6014 or	DIODE	ISS133(DS)	(1)	223280	
PCB2	D6015	DIODE	ISS133	1	223163	
PCB2	D6015 or	DIODE	ISS270A	(1)	223205	
PCB2	D6015 or	DIODE	ISS133(DS)	(1)	223280	
PCB2	D6701	DIODE	ISS133	1	223163	
PCB2	D6701 or	DIODE	ISS270A	(1)	223205	
PCB2	D6701 or	DIODE	ISS133(DS)	(1)	223280	
PCB2	D6702	DIODE	ISS133	1	223163	
PCB2	D6702 or	DIODE	ISS270A	(1)	223205	
PCB2	D6702 or	DIODE	ISS133(DS)	(1)	223280	
PCB2	D6703	ZENER D	MTZJ5.1B	1	224470512	
PCB2	D6703 or	ZENER D	DZ-5.1BSB	(1)	224850512	
PCB2	D6704	ZENER D	MTZJ5.1B	1	224470512	
PCB2	D6704 or	ZENER D	DZ-5.1BSB	(1)	224850512	
PCB2	D6901	DIODE	ISS133	1	223163	
PCB2	D6901 or	DIODE	ISS270A	(1)	223205	
PCB2	D6901 or	DIODE	ISS133(DS)	(1)	223280	
PCB2	D6902	DIODE	ISS133	1	223163	
PCB2	D6902 or	DIODE	ISS270A	(1)	223205	

PCB2	D6902 or	DIODE	ISS133(DS)	(1)	223280
PCB2	D6904	DIODE	D5SBA20	1	22380130F
PCB2	D6904 or	DIODE	RS603M-B42	(1)	22380274F
PCB2	D6904 or	DIODE	RBV602	(1)	22380038F
PCB2	D6905	DIODE	D5SBA20	1	22380130F
PCB2	D6905 or	DIODE	RS603M-B42	(1)	22380274F
PCB2	D6905 or	DIODE	RBV602	(1)	22380038F
PCB2	D6906	DIODE	ISS133	1	223163
PCB2	D6906 or	DIODE	ISS270A	(1)	223205
PCB2	D6906 or	DIODE	ISS133(DS)	(1)	223280
PCB2	D9005	DIODE	D3SBA20	1	22380271F
PCB2	D9005 or	DIODE	RS403M	(1)	22380285F
PCB2	D9011	DIODE	RL1N4003	1	22380260
PCB2	D9011 or	DIODE	GP104003E	(1)	22380035
PCB2	C5503	TF C	ECQ-B50V-221K	1	374722215
PCB2	C5504	TF C	ECQ-B50V-221K	1	374722215
PCB2	C5507	C-CERA C	CC725CH1H-221J1	1	342102214R1
PCB2	C5508	C-CERA C	CC725CH1H-221J1	1	342102214R1
PCB2	C5509	C-CERA C	CC725CH1H-221J1	1	342102214R1
PCB2	C5510	C-CERA C	CC725CH1H-221J1	1	342102214R1
PCB2	C5513	C-CERA C	CC725CH1H-221J1	1	342102214R1
PCB2	C5514	C-CERA C	CC725CH1H-221J1	1	342102214R1
PCB2	C5517	C-CERA C	CC725CH1H-221J1	1	342102214R1
PCB2	C5518	C-CERA C	CC725CH1H-221J1	1	342102214R1
PCB2	C5519	C-CERA C	CC725CH1H-221J1	1	342102214R1
PCB2	C5520	C-CERA C	CC725CH1H-221J1	1	342102214R1
PCB2	C5521	C-CERA C	CC725CH1H-221J1	1	342102214R1
PCB2	C5522	C-CERA C	CC725CH1H-221J1	1	342102214R1
PCB2	C5523	C-CERA C	CC725CH1H-221J1	1	342102214R1
PCB2	C5524	C-CERA C	CC725CH1H-221J1	1	342102214R1
PCB2	C5550	VX C	CE04W50V-4.7M(VX)	1	393380477
PCB2	C5551	MMT C	MMT50V-224J	1	375522244
PCB2	C5552	TF C	ECQ-B50V-472J	1	374724724
PCB2	C5553	VX C	CE04W50V-4.7M(VX)	1	393380477
PCB2	C5554	MMT C	MMT50V-224J	1	375522244
PCB2	C5555	TF C	ECQ-B50V-472J	1	374724724
PCB2	C5556	VX C	CE04W25V-47M(VX)	1	393354707
PCB2	C5557	VX C	CE04W25V-47M(VX)	1	393354707
PCB2	C5558	VX C	CE04W25V-47M(VX)	1	393354707
PCB2	C5559	VX C	CE04W25V-47M(VX)	1	393354707
PCB2	C5560	VX C	CE04W25V-47M(VX)	1	393354707
PCB2	C5561	VX C	CE04W25V-47M(VX)	1	393354707
PCB2	C5562	VX C	CE04W25V-47M(VX)	1	393354707
PCB2	C5563	VX C	CE04W25V-47M(VX)	1	393354707
PCB2	C5564	VX C	CE04W50V-10M(VX)	1	393381007
PCB2	C5565	VX C	CE04W50V-10M(VX)	1	393381007
PCB2	C5566	VX C	CE04W50V-10M(VX)	1	393381007
PCB2	C5567	VX C	CE04W50V-10M(VX)	1	393381007
PCB2	C5568	VX C	CE04W50V-10M(VX)	1	393381007
PCB2	C5569	VX C	CE04W50V-10M(VX)	1	393381007
PCB2	C5570	VX C	CE04W50V-10M(VX)	1	393381007

PCB2	C5571	VX C	CE04W50V-10M(VX)	1	393381007
PCB2	C5572	VX C	CE04W50V-10M(VX)	1	393381007
PCB2	C5573	VX C	CE04W50V-10M(VX)	1	393381007
PCB2	C5574	VX C	CE04W50V-10M(VX)	1	393381007
PCB2	C5575	VX C	CE04W50V-10M(VX)	1	393381007
PCB2	C5576	VX C	CE04W50V-10M(VX)	1	393381007
PCB2	C5577	VX C	CE04W50V-10M(VX)	1	393381007
PCB2	C5578	VX C	CE04W50V-1M(VX)	1	393380107
PCB2	C5590	C-CERA C	CC725CH1H-330J1	1	342103304R1
PCB2	C5591	C-CERA C	CC725CH1H-330J1	1	342103304R1
PCB2	C5600	VX C	CE04W50V-47M(VX)	1	393384707
PCB2	C5601	VX C	CE04W50V-47M(VX)	1	393384707
PCB2	C5602	VX C	CE04W50V-47M(VX)	1	393384707
PCB2	C5603	VX C	CE04W50V-47M(VX)	1	393384707
PCB2	C5604	VX C	CE04W50V-47M(VX)	1	393384707
PCB2	C5607	VX C	CE04W50V-2.2M(VX)	1	393380227
PCB2	C5608	VX C	CE04W50V-47M(VX)	1	393384707
PCB2	C5609	VX C	CE04W50V-47M(VX)	1	393384707
PCB2	C5630	VX C	CE04W50V-10M(VX)	1	393381007
PCB2	C5631	C-CERA C	CC725CH1H-221J1	1	342102214R1
PCB2	C5632	C-CERA C	CK725B1H-103K1	1	332101035R1
PCB2	C5640	VX C	CE04W50V-22M(VX)	1	393382207
PCB2	C5641	VX C	CE04W50V-22M(VX)	1	393382207
PCB2	C5642	VX C	CE04W50V-22M(VX)	1	393382207
PCB2	C5643	VX C	CE04W50V-22M(VX)	1	393382207
PCB2	C5660	VX C	CE04W50V-10M(VX)	1	393381007
PCB2	C5661	VX C	CE04W50V-10M(VX)	1	393381007
PCB2	C5662	VX C	CE04W50V-10M(VX)	1	393381007
PCB2	C5663	VX C	CE04W50V-10M(VX)	1	393381007
PCB2	C5664	VX C	CE04W25V-100M(VX)	1	393351017
PCB2	C5665	VX C	CE04W25V-100M(VX)	1	393351017
PCB2	C5666	VX C	CE04W25V-220M(VX)	1	393352217
PCB2	C5667	VX C	CE04W25V-220M(VX)	1	393352217
PCB2	C5668	VX C	CE04W25V-220M(VX)	1	393352217
PCB2	C5669	VX C	CE04W25V-220M(VX)	1	393352217
PCB2	C5673	VX C	CE04W25V-220M(VX)	1	393352217
PCB2	C5674	VX C	CE04W25V-220M(VX)	1	393352217
PCB2	C5702	C-CERA C	CK725B1H-103K1	1	332101035R1
PCB2	C5705	C-CERA C	CK725B1H-103K1	1	332101035R1
PCB2	C5707	C-CERA C	CK725B1H-103K1	1	332101035R1
PCB2	C5708	C-CERA C	CK725B1H-103K1	1	332101035R1
PCB2	C5712	TF C	ECQ-B50V-102J	1	374721024
PCB2	C6040	ELECT C	CE04W50V-47M(VZ)	1	394584707
PCB2	C6041	ELECT C	CE04W50V-47M(VZ)	1	394584707
PCB2	C6042	ELECT C	CE04W50V-47M(VZ)	1	394584707
PCB2	C6043	ELECT C	CE04W50V-47M(VZ)	1	394584707
PCB2	C6044	ELECT C	CE04W50V-47M(VZ)	1	394584707
PCB2	C6045	ELECT C	CE04W50V-47M(VZ)	1	394584707
PCB2	C6230	TF C	ECQ-V50V-473J	1	374724734
PCB2	C6231	TF C	ECQ-V50V-473J	1	374724734
PCB2	C6232	TF C	ECQ-V50V-473J	1	374724734

PCB2	C6233	TF C	ECQ-V50V-473J	1	374724734
PCB2	C6234	TF C	ECQ-V50V-473J	1	374724734
PCB2	C6235	TF C	ECQ-V50V-473J	1	374724734
PCB2	C6701	VR C	CE04W16V-100M(VR)	1	394641017
PCB2	C6703	CERA C	CK45F50V-223Z	1	335622230
PCB2	C6704	VX C	CE04W100V-1M(VX)	1	393390107
PCB2	C6706	VR C	CE04W16V-100M(VR)	1	394641017
PCB2	C6901	ELECT C	CE69W63V-10000MA	1	3504417
PCB2	C6901 or	ELECT C	CE69W63V-10000MB	(1)	3504418
PCB2	C6902	ELECT C	CE69W63V-10000MA	1	3504417
PCB2	C6902 or	ELECT C	CE69W63V-10000MB	(1)	3504418
PCB2	C6903	TF C	ECQ-B50V-102J	1	374721024
PCB2	C6904	TF C	ECQ-V100-334J	1	374733344
PCB2	C6905	TF C	ECQ-V100-334J	1	374733344
PCB2	C6906	TF C	ECQ-V50V-104J	1	374721044
PCB2	C6907	TF C	ECQ-V50V-104J	1	374721044
PCB2	C9005	MMT C	MMT50V-334J	1	375523344
PCB2	C9010	VR C	CE04W16V-4700M(VR)	1	394644727S
PCB2	C9017	TF C	ECQ-B50V-102J	1	374721024
PCB2	R5503	C-CARBON R	RN72K1J-331JE	1	435033314R1
PCB2	R5504	C-CARBON R	RN72K1J-331JE	1	435033314R1
PCB2	R5505	C-CARBON R	RN72K1J-331JE	1	435033314R1
PCB2	R5506	C-CARBON R	RN72K1J-331JE	1	435033314R1
PCB2	R5507	C-CARBON R	RN72K1J-331JE	1	435033314R1
PCB2	R5508	C-CARBON R	RN72K1J-331JE	1	435033314R1
PCB2	R5513	C-CARBON R	RN72K1J-331JE	1	435033314R1
PCB2	R5514	C-CARBON R	RN72K1J-331JE	1	435033314R1
PCB2	R5515	C-CARBON R	RN72K1J-331JE	1	435033314R1
PCB2	R5516	C-CARBON R	RN72K1J-331JE	1	435033314R1
PCB2	R5517	C-CARBON R	RN72K1J-331JE	1	435033314R1
PCB2	R5518	C-CARBON R	RN72K1J-331JE	1	435033314R1
PCB2	R5519	C-CARBON R	RN72K1J-331JE	1	435033314R1
PCB2	R5520	C-CARBON R	RN72K1J-331JE	1	435033314R1
PCB2	R5521	C-CARBON R	RN72K1J-331JE	1	435033314R1
PCB2	R5522	C-CARBON R	RN72K1J-331JE	1	435033314R1
PCB2	R5523	C-CARBON R	RN72K1J-331JE	1	435033314R1
PCB2	R5524	C-CARBON R	RN72K1J-331JE	1	435033314R1
PCB2	R5545	C-CARBON R	RN72K1J-563JE	1	435035634R1
PCB2	R5546	C-CARBON R	RN72K1J-563JE	1	435035634R1
PCB2	R5551	C-CARBON R	RN72K1J-563JE	1	435035634R1
PCB2	R5552	C-CARBON R	RN72K1J-563JE	1	435035634R1
PCB2	R5555	C-CARBON R	RN72K1J-563JE	1	435035634R1
PCB2	R5556	C-CARBON R	RN72K1J-563JE	1	435035634R1
PCB2	R5561	C-CARBON R	RN72K1J-563JE	1	435035634R1
PCB2	R5562	C-CARBON R	RN72K1J-563JE	1	435035634R1
PCB2	R5563	C-CARBON R	RN72K1J-563JE	1	435035634R1
PCB2	R5564	C-CARBON R	RN72K1J-563JE	1	435035634R1
PCB2	R5581	C-CARBON R	RN72K1J-221JE	1	435032214R1
PCB2	R5582	C-CARBON R	RN72K1J-221JE	1	435032214R1
PCB2	R5583	C-CARBON R	RN72K1J-221JE	1	435032214R1
PCB2	R5587	C-CARBON R	RN72K1J-221JE	1	435032214R1

PCB2	R5588	C-CARBON R	RN72K1J-221JE	1	435032214R1
PCB2	R5589	C-CARBON R	RN72K1J-221JE	1	435032214R1
PCB2	R5590	C-CARBON R	RN72K1J-103JE	1	435031034R1
PCB2	R5591	C-CARBON R	RN72K1J-103JE	1	435031034R1
PCB2	R5592	C-CARBON R	RN72K1J-471JE	1	435034714R1
PCB2	R5593	C-CARBON R	RN72K1J-122JE	1	435031224R1
PCB2	R5594	C-CARBON R	RN72K1J-103JE	1	435031034R1
PCB2	R5595	C-CARBON R	RN72K1J-103JE	1	435031034R1
PCB2	R5596	C-CARBON R	RN72K1J-471JE	1	435034714R1
PCB2	R5597	C-CARBON R	RN72K1J-122JE	1	435031224R1
PCB2	R5598	C-CARBON R	RN72K1J-103JE	1	435031034R1
PCB2	R5599	C-CARBON R	RN72K1J-103JE	1	435031034R1
PCB2	R5600	C-CARBON R	RN72K1J-224JE	1	435032244R1
PCB2	R5601	C-CARBON R	RN72K1J-224JE	1	435032244R1
PCB2	R5602	C-CARBON R	RN72K1J-224JE	1	435032244R1
PCB2	R5603	C-CARBON R	RN72K1J-224JE	1	435032244R1
PCB2	R5604	C-CARBON R	RN72K1J-224JE	1	435032244R1
PCB2	R5607	C-CARBON R	RN72K1J-222JE	1	435032224R1
PCB2	R5610	C-CARBON R	RN72K1J-222JE	1	435032224R1
PCB2	R5611	C-CARBON R	RN72K1J-222JE	1	435032224R1
PCB2	R5612	C-CARBON R	RN72K1J-222JE	1	435032224R1
PCB2	R5613	C-CARBON R	RN72K1J-222JE	1	435032224R1
PCB2	R5614	C-CARBON R	RN72K1J-222JE	1	435032224R1
PCB2	R5617	C-CARBON R	RN72K1J-271JE	1	435032714R1
PCB2	R5620	C-CARBON R	RN72K1J-000JE	1	435030004R1
PCB2	R5621	C-CARBON R	RN72K1J-000JE	1	435030004R1
PCB2	R5622	C-CARBON R	RN72K1J-000JE	1	435030004R1
PCB2	R5623	C-CARBON R	RN72K1J-000JE	1	435030004R1
PCB2	R5624	C-CARBON R	RN72K1J-000JE	1	435030004R1
PCB2	R5627	C-CARBON R	RN72K1J-101JE	1	435031014R1
PCB2	R5630	C-CARBON R	RN72K1J-221JE	1	435032214R1
PCB2	R5631	C-CARBON R	RN72K1J-473JE	1	435034734R1
PCB2	R5632	C-CARBON R	RN72K1J-153JE	1	435031534R1
PCB2	R5633	C-CARBON R	RN72K1J-122JE	1	435031224R1
PCB2	R5634	C-CARBON R	RN72K1J-103JE	1	435031034R1
PCB2	R5640	CARBON R	R25J-0.22	1	415472294
PCB2	R5660	METAL O R	RS2WBJ-12	1	442721204F
PCB2	R5661	METAL O R	RS2WBJ-22	1	442722204F
PCB2	R5662	C-CARBON R	RN72K1J-220JE	1	435032204R1
PCB2	R5663	C-CARBON R	RN72K1J-220JE	1	435032204R1
PCB2	R5664	METAL O R	RS1WBJ-68	1	443626804
PCB2	R5665	METAL O R	RS1WBJ-68	1	443626804
PCB2	R5666	CARBON R	R16J-22	1	417342204
PCB2	R5667	CARBON R	R16J-22	1	417342204
PCB2	R5671	CARBON R	R16J-22	1	417342204
PCB2	R5672	CARBON R	R16J-22	1	417342204
PCB2	R5680	C-CARBON R	RN72K1J-104JE	1	435031044R1
PCB2	R5681	C-CARBON R	RN72K1J-104JE	1	435031044R1
PCB2	R5682	CARBON R	R16J-100K	1	417341044
PCB2	R5704	C-CARBON R	RN72K1J-331JE	1	435033314R1
PCB2	R5706	C-CARBON R	RN72K1J-331JE	1	435033314R1

PCB2	R5800	C-CARBON R	RN72K1J-000JE	1	435030004R1
PCB2	R5801	C-CARBON R	RN72K1J-000JE	1	435030004R1
PCB2	R5802	C-CARBON R	RN72K1J-000JE	1	435030004R1
PCB2	R5803	C-CARBON R	RN72K1J-000JE	1	435030004R1
PCB2	R5804	C-CARBON R	RN72K1J-000JE	1	435030004R1
PCB2	R5805	C-CARBON R	RN72K1J-000JE	1	435030004R1
PCB2	R5806	C-CARBON R	RN72K1J-000JE	1	435030004R1
PCB2	R5807	C-CARBON R	RN72K1J-000JE	1	435030004R1
PCB2	R5808	C-CARBON R	RN72K1J-000JE	1	435030004R1
PCB2	R5809	C-CARBON R	RN72K1J-000JE	1	435030004R1
PCB2	R5810	C-CARBON R	RN72K1J-000JE	1	435030004R1
PCB2	R5814	C-CARBON R	RN72K1J-000JE	1	435030004R1
PCB2	R6000	CARBON R	R16J-5.6K	1	417345624
PCB2	R6001	CARBON R	R16J-5.6K	1	417345624
PCB2	R6002	CARBON R	R16J-5.6K	1	417345624
PCB2	R6003	CARBON R	R16J-5.6K	1	417345624
PCB2	R6004	CARBON R	R16J-5.6K	1	417345624
PCB2	R6005	CARBON R	R16J-5.6K	1	417345624
PCB2	R6010	CARBON R	R16J-3.9K	1	417343924
PCB2	R6011	CARBON R	R16J-3.9K	1	417343924
PCB2	R6012	CARBON R	R16J-3.9K	1	417343924
PCB2	R6013	CARBON R	R16J-3.9K	1	417343924
PCB2	R6014	CARBON R	R16J-3.9K	1	417343924
PCB2	R6015	CARBON R	R16J-3.9K	1	417343924
PCB2	R6020	NF CARBON R	R25J-2.2	1	415470224
PCB2	R6021	NF CARBON R	R25J-2.2	1	415470224
PCB2	R6022	NF CARBON R	R25J-2.2	1	415470224
PCB2	R6023	NF CARBON R	R25J-2.2	1	415470224
PCB2	R6024	NF CARBON R	R25J-2.2	1	415470224
PCB2	R6025	NF CARBON R	R25J-2.2	1	415470224
PCB2	R6030	CARBON R	R16J-470	1	417344714
PCB2	R6031	CARBON R	R16J-470	1	417344714
PCB2	R6032	CARBON R	R16J-470	1	417344714
PCB2	R6033	CARBON R	R16J-470	1	417344714
PCB2	R6034	CARBON R	R16J-470	1	417344714
PCB2	R6035	CARBON R	R16J-470	1	417344714
PCB2	R6040	TRIM R	N06HR2KBC	1	5210390
PCB2	R6041	TRIM R	N06HR2KBC	1	5210390
PCB2	R6042	TRIM R	N06HR2KBC	1	5210390
PCB2	R6043	TRIM R	N06HR2KBC	1	5210390
PCB2	R6044	TRIM R	N06HR2KBC	1	5210390
PCB2	R6045	TRIM R	N06HR2KBC	1	5210390
PCB2	R6050	CARBON R	R16J-3.3K	1	417343324
PCB2	R6051	CARBON R	R16J-3.3K	1	417343324
PCB2	R6052	CARBON R	R16J-3.3K	1	417343324
PCB2	R6053	CARBON R	R16J-3.3K	1	417343324
PCB2	R6054	CARBON R	R16J-3.3K	1	417343324
PCB2	R6055	CARBON R	R16J-3.3K	1	417343324
PCB2	R6070	NF CARBON R	R25J-82	1	415478204
PCB2	R6071	NF CARBON R	R25J-82	1	415478204
PCB2	R6072	NF CARBON R	R25J-82	1	415478204

PCB2	R6073	NF CARBON R	R25J-120	1	415471214
PCB2	R6074	NF CARBON R	R25J-120	1	415471214
PCB2	R6075	NF CARBON R	R25J-220	1	415472214
PCB2	R6080	CARBON R	R25J-0.22	1	415472294
PCB2	R6081	CARBON R	R25J-0.22	1	415472294
PCB2	R6082	CARBON R	R25J-0.22	1	415472294
PCB2	R6083	CARBON R	R25J-0.22	1	415472294
PCB2	R6084	CARBON R	R25J-0.22	1	415472294
PCB2	R6085	CARBON R	R25J-0.22	1	415472294
PCB2	R6090	CARBON R	R25J-0.22	1	415472294
PCB2	R6091	CARBON R	R25J-0.22	1	415472294
PCB2	R6092	CARBON R	R25J-0.22	1	415472294
PCB2	R6093	CARBON R	R25J-0.22	1	415472294
PCB2	R6094	CARBON R	R25J-0.22	1	415472294
PCB2	R6095	CARBON R	R25J-0.22	1	415472294
PCB2	R6100	CEMENT R	RSS2WK-0.22	1	4800071
PCB2	R6100 or	OTHER R	RGC22-0.22 OHMK	(1)	4000131
PCB2	R6100 or	METAL PR	MPC708-2WK-0.22	(1)	4500027
PCB2	R6101	CEMENT R	RSS2WK-0.22	1	4800071
PCB2	R6101 or	OTHER R	RGC22-0.22 OHMK	(1)	4000131
PCB2	R6101 or	METAL PR	MPC708-2WK-0.22	(1)	4500027
PCB2	R6102	CEMENT R	RSS2WK-0.22	1	4800071
PCB2	R6102 or	OTHER R	RGC22-0.22 OHMK	(1)	4000131
PCB2	R6102 or	METAL PR	MPC708-2WK-0.22	(1)	4500027
PCB2	R6103	CEMENT R	RSS2WK-0.22	1	4800071
PCB2	R6103 or	OTHER R	RGC22-0.22 OHMK	(1)	4000131
PCB2	R6103 or	METAL PR	MPC708-2WK-0.22	(1)	4500027
PCB2	R6104	CEMENT R	RSS2WK-0.22	1	4800071
PCB2	R6104 or	OTHER R	RGC22-0.22 OHMK	(1)	4000131
PCB2	R6104 or	METAL PR	MPC708-2WK-0.22	(1)	4500027
PCB2	R6105	CEMENT R	RSS2WK-0.22	1	4800071
PCB2	R6105 or	OTHER R	RGC22-0.22 OHMK	(1)	4000131
PCB2	R6105 or	METAL PR	MPC708-2WK-0.22	(1)	4500027
PCB2	R6140	CARBON R	R16J-22K	1	417342234
PCB2	R6141	CARBON R	R16J-22K	1	417342234
PCB2	R6142	CARBON R	R16J-22K	1	417342234
PCB2	R6143	CARBON R	R16J-22K	1	417342234
PCB2	R6144	CARBON R	R16J-22K	1	417342234
PCB2	R6145	CARBON R	R16J-22K	1	417342234
PCB2	R6150	CARBON R	R16J-12K	1	417341234
PCB2	R6151	CARBON R	R16J-12K	1	417341234
PCB2	R6152	CARBON R	R16J-12K	1	417341234
PCB2	R6153	CARBON R	R16J-12K	1	417341234
PCB2	R6154	CARBON R	R16J-12K	1	417341234
PCB2	R6155	CARBON R	R16J-12K	1	417341234
PCB2	R6160	CARBON R	R16J-33K	1	417343334
PCB2	R6161	CARBON R	R16J-33K	1	417343334
PCB2	R6162	CARBON R	R16J-33K	1	417343334
PCB2	R6163	CARBON R	R16J-33K	1	417343334
PCB2	R6164	CARBON R	R16J-33K	1	417343334
PCB2	R6165	CARBON R	R16J-33K	1	417343334

PCB2	R6170	CARBON R	R16J-47K	1	417344734	
PCB2	R6171	CARBON R	R16J-47K	1	417344734	
PCB2	R6172	CARBON R	R16J-47K	1	417344734	
PCB2	R6173	CARBON R	R16J-47K	1	417344734	
PCB2	R6174	CARBON R	R16J-47K	1	417344734	
PCB2	R6175	CARBON R	R16J-47K	1	417344734	
PCB2	R6180	CARBON R	R16J-47K	1	417344734	
PCB2	R6181	CARBON R	R16J-47K	1	417344734	
PCB2	R6182	CARBON R	R16J-47K	1	417344734	
PCB2	R6183	CARBON R	R16J-47K	1	417344734	
PCB2	R6184	CARBON R	R16J-47K	1	417344734	
PCB2	R6185	CARBON R	R16J-47K	1	417344734	
PCB2	R6190	CARBON R	R16J-220K	1	417342244	
PCB2	R6191	CARBON R	R16J-220K	1	417342244	
PCB2	R6192	CARBON R	R16J-220K	1	417342244	
PCB2	R6193	CARBON R	R16J-220K	1	417342244	
PCB2	R6194	CARBON R	R16J-220K	1	417342244	
PCB2	R6195	CARBON R	R16J-220K	1	417342244	
PCB2	R6230	METAL R	RNU1WCJ-8.2	1	453630824	
PCB2	R6231	METAL R	RNU1WCJ-8.2	1	453630824	
PCB2	R6232	METAL R	RNU1WCJ-8.2	1	453630824	
PCB2	R6233	METAL R	RNU1WCJ-8.2	1	453630824	
PCB2	R6234	METAL R	RNU1WCJ-8.2	1	453630824	
PCB2	R6235	METAL R	RNU1WCJ-8.2	1	453630824	
PCB2	R6701	CARBON R	R16J-22K	1	417342234	
PCB2	R6702	CARBON R	R16J-10K	1	417341034	
PCB2	R6704	CARBON R	R16J-47K	1	417344734	
PCB2	R6706	CARBON R	R16J-220K	1	417342244	
PCB2	R6708	CARBON R	R16J-33K	1	417343334	
PCB2	R6709	CARBON R	R16J-5.6K	1	417345624	
PCB2	R6710	CARBON R	R16J-33K	1	417343334	
PCB2	R6750	METAL O R	RS1/2WBJ-390	1	443523914	
PCB2	R6751	METAL O R	RS1/2WBJ-390	1	443523914	
PCB2	R6901	METAL O R	RS1/2WBJ-10	1	443521004	
PCB2	R6902	CARBON R	R16J-1K	1	417341024	
PCB2	RL6901	RELAY SW	NRL-1P5A-DC12-102	1	25065526	!
PCB2	RL6901 or	RELAY	NRL-1P5A-DC12-127	(1)	25065561	!
PCB2	RL6902	RELAY SW	NRL-1P5A-DC12-102	1	25065526	!
PCB2	RL6902 or	RELAY	NRL-1P5A-DC12-127	(1)	25065561	!
PCB2	P301	PLUG	NPLG-10P0965	1	25056015	
PCB2	P302	PLUG	NPLG-20P0975	1	25056025	
PCB2	P303	PLUG	NPLG-20P0975	1	25056025	
PCB2	P311B	PLUG	NPLG-10P138	1	25055154	
PCB2	P5504	SOCKET AS	NSAS-26P1494	1	2009990954UL	
PCB2	P5504 or	SOCKET AS	NSAS-26P1527	(1)	2009990966UL	
PCB2	P5505	TRM(SCREW)	NEGITANSI M3	1	25065425	
PCB2	P6000B	PLUG	NPLG-5P0960	1	25056010	
PCB2	P6001B	PLUG	NPLG-5P0960	1	25056010	
PCB2	P6002B	PLUG	NPLG-5P0960	1	25056010	
PCB2	P6003B	PLUG	NPLG-5P0960	1	25056010	
PCB2	P6004B	PLUG	NPLG-5P0960	1	25056010	

PCB2	P6005B	PLUG	NPLG-5P0960	1	25056010	
PCB2	P6011C	TRM	NTM-1P232(M1700)	1	25060301	
PCB2	P6080	PLUG	NPLG-2P29	1	25055038	
PCB2	P6081	PLUG	NPLG-2P29	1	25055038	
PCB2	P6082	PLUG	NPLG-2P29	1	25055038	
PCB2	P6083	PLUG	NPLG-2P29	1	25055038	
PCB2	P6084	PLUG	NPLG-2P29	1	25055038	
PCB2	P6085	PLUG	NPLG-2P29	1	25055038	
PCB2	P6380	RETAINER	(PTH)	1	27141884-1	
PCB2	P6380 or	RETAINER	(PTH)	(1)	27141884	
PCB2	P6844	WS CLAMP	CB-71683(L=50)	1	260261	
PCB2	P6845	WS CLAMP	CB-71683(L=50)	1	260261	
PCB2	P6849	WS CLAMP	CB-71683(L=50)	1	260261	
PCB2	P6850	HOLDER	HOLDER(CLAMP)	1	27190540-1	
PCB2	P6851	HOLDER	HOLDER(CLAMP)	1	27190540-1	
PCB2	P6906	TRM(SCREW)	NEGITANSI M3	1	25065425	
PCB2	P7902	PIN JACK	NPJ-6PDWWRRR561	1	25045779	
PCB2	P7902 or	PIN JACK	NPJ-6PDBL159	(1)	25045300	
PCB2	P7903	PIN JACK	NPJ-4PDWWRR624	1	25045845	
PCB2	P7903 or	PIN JACK	NPJ-4PDBL162	(1)	25045303	
PCB2	P7904	PIN JACK	NPJ-4PDWWRR624	1	25045845	
PCB2	P7904 or	PIN JACK	NPJ-4PDBL162	(1)	25045303	
PCB2	P7905	PIN JACK	NPJ-6PDWLGREP562	1	25045780	
PCB2	P7905 or	PIN JACK	NPJ-6PWRLGGP493	(1)	25045697	
PCB2	P9502	SOCKET	14PK-FJ	1	25053058	
PCB2	E301A	TRM	NTM-1P232(M1700)	1	25060301	
PCB2	F6901A	FUSE HOL	NSCT-1P2031	1	25052133	!
PCB2	F6901B	FUSE HOL	NSCT-1P2031	1	25052133	!
PCB2	F6902A	FUSE HOL	NSCT-1P2031	1	25052133	!
PCB2	F6902B	FUSE HOL	NSCT-1P2031	1	25052133	!
PCB2	J010	CRIMP AS	CRIMP AS	1	2069925226UL	
PCB2	J011	CRIMP AS	CRIMP AS	1	2069925153UL	
PCB2	JL5501A	WIRE HOL	NSCT-12P883	1	25051096	
PCB2	JL5501B	WIRE HOL	NSCT-12P883	1	25051096	
PCB2	JL6402A	WIRE HOL	NSCT-3P874	1	25051087	
PCB2	JL6402B	WIRE HOL	NSCT-3P874	1	25051087	
PCB2	JL6600A	WIRE HOL	NSCT-7P898	1	25051111	
PCB2	JL6603A	WIRE HOL	NSCT-9P900	1	25051113	
PCB2	JL6951A	WIRE HOL	NSCT-5P896	1	25051109	
PCB2	JL6951B	WIRE HOL	NSCT-5P896	1	25051109	
PCB2	JL6952A	WIRE HOL	NSCT-5P896	1	25051109	
PCB2	JL6952B	WIRE HOL	NSCT-5P896	1	25051109	
PCB2	JL891B	SOCKET	NSCT-5P97	1	25050269	

U11	POWER SUPPLY-1 PC BOARD (NAPS-8544-1B/1C/1K)
U13	POWER SUPPLY-2 PC BOARD (NAPS-8546-1B/1C/1K)
U14	SEC. TERMINAL-1 PC BOARD (NAPS-8547-1B/1C/1K)
U15	SPEAKER TERMINAL PC BOARD (NAETC-8548-1B/1C/1K)
U16	VIDEO PC BOARD (NAVD-8549-1B/1C/1K)
U17	DRIVER AMPLIFIER PC BOARD (NAAF-8550-1B/1C/1K)

	CIRCUIT NO.	PART NAME	DESCRIPTION	Q'TY	PART NO (SN)	REMARKS
PCB3	Q930	IC	SI-3010KF	1	22242203	<WT>
PCB3	Q1003	IC	LA7956	1	22241759	
PCB3	Q921	TR	2SC2458-GR	1	2212115	
PCB3	Q921 or	TR	2SC2458-BL	(1)	2212116	
PCB3	Q921 or	TR	KTC3199-GR	(1)	2215864	
PCB3	Q1001	TR	RN1241-A	1	2213631	
PCB3	Q1001 or	TR	RN1241-B	(1)	2213632	
PCB3	Q1002	TR	RN1241-A	1	2213631	
PCB3	Q1002 or	TR	RN1241-B	(1)	2213632	
PCB3	Q1004	TR	2SA933S-R	1	2213354	
PCB3	Q1004 or	TR	2SA933S-S	(1)	2213355	
PCB3	Q1004 or	TR	KTA1267-GR	(1)	2215995	
PCB3	Q1005	TR	DTA114ES	1	2213510	
PCB3	Q1005 or	TR	KRA102M	(1)	2215770	
PCB3	Q1006	TR	DTA114ES	1	2213510	
PCB3	Q1006 or	TR	KRA102M	(1)	2215770	
PCB3	Q1015	TR	RN1241-A	1	2213631	
PCB3	Q1015 or	TR	RN1241-B	(1)	2213632	
PCB3	Q1016	TR	RN1241-A	1	2213631	
PCB3	Q1016 or	TR	RN1241-B	(1)	2213632	
PCB3	Q1018	TR	RN1241-A	1	2213631	
PCB3	Q1018 or	TR	RN1241-B	(1)	2213632	
PCB3	Q5000	TR	2SC2240-BL	1	2211406	
PCB3	Q5001	TR	2SC2240-BL	1	2211406	
PCB3	Q5002	TR	2SC2240-BL	1	2211406	
PCB3	Q5003	TR	2SC2240-BL	1	2211406	
PCB3	Q5003 or	TR	KTC3200-BL	(1)	2215896	
PCB3	Q5004	TR	2SC2240-BL	1	2211406	
PCB3	Q5004 or	TR	KTC3200-BL	(1)	2215896	
PCB3	Q5005	TR	2SC2240-BL	1	2211406	
PCB3	Q5005 or	TR	KTC3200-BL	(1)	2215896	
PCB3	Q5010	TR	2SC2240-BL	1	2211406	
PCB3	Q5011	TR	2SC2240-BL	1	2211406	
PCB3	Q5012	TR	2SC2240-BL	1	2211406	
PCB3	Q5013	TR	2SC2240-BL	1	2211406	
PCB3	Q5013 or	TR	KTC3200-BL	(1)	2215896	
PCB3	Q5014	TR	2SC2240-BL	1	2211406	
PCB3	Q5014 or	TR	KTC3200-BL	(1)	2215896	
PCB3	Q5015	TR	2SC2240-BL	1	2211406	
PCB3	Q5015 or	TR	KTC3200-BL	(1)	2215896	
PCB3	Q5030	TR	2SA949-Y	1	2211354	
PCB3	Q5031	TR	2SA949-Y	1	2211354	
PCB3	Q5032	TR	2SA949-Y	1	2211354	
PCB3	Q5033	TR	2SA949-Y	1	2211354	
PCB3	Q5034	TR	2SA949-Y	1	2211354	
PCB3	Q5035	TR	2SA949-Y	1	2211354	
PCB3	Q5040	TR	2SC2229-Y	1	2211634	
PCB3	Q5041	TR	2SC2229-Y	1	2211634	
PCB3	Q5042	TR	2SC2229-Y	1	2211634	
PCB3	Q5043	TR	2SC2229-Y	1	2211634	

PCB3	Q5044	TR	2SC2229-Y	1	2211634	
PCB3	Q5045	TR	2SC2229-Y	1	2211634	
PCB3	Q5050	TR	2SC1815-GR	1	2211255	
PCB3	Q5050 or	TR	2SC1815-BL	(1)	2211256	
PCB3	Q5051	TR	2SC1815-GR	1	2211255	
PCB3	Q5051 or	TR	2SC1815-BL	(1)	2211256	
PCB3	Q5052	TR	2SC1815-GR	1	2211255	
PCB3	Q5052 or	TR	2SC1815-BL	(1)	2211256	
PCB3	Q5053	TR	2SC1815-GR	1	2211255	
PCB3	Q5053 or	TR	2SC1815-BL	(1)	2211256	
PCB3	Q5054	TR	2SC1815-GR	1	2211255	
PCB3	Q5054 or	TR	2SC1815-BL	(1)	2211256	
PCB3	Q5055	TR	2SC1815-GR	1	2211255	
PCB3	Q5055 or	TR	2SC1815-BL	(1)	2211256	
PCB3	Q9002	TR	KTA1268-GR	1	2215885	
PCB3	Q9002 or	TR	KTA1268-BL	(1)	2215886	
PCB3	Q9002 or	TR	2SA970-GR	(1)	2211395	
PCB3	Q9002 or	TR	2SA970-BL	(1)	2211396	
PCB3	Q9021	TR	2SA1015-GR	1	2211455	<WT>
PCB3	Q9021 or	TR	2SA1015-Y	(1)	2211454	<WT>
PCB3	Q9022	TR	RN2202	1	2214350	<WT>
PCB3	Q9022 or	TR	KRA102M	(1)	2215770	<WT>
PCB3	Q9023	TR	RN1202	1	2214230	<WT>
PCB3	Q9023 or	TR	KRC102M	(1)	2215960	<WT>
PCB3	D921	DIODE	1SS133(DS)	1	223280	
PCB3	D921 or	DIODE	1SS133	(1)	223163	
PCB3	D921 or	DIODE	1SS270A	(1)	223205	
PCB3	D922	DIODE	1SS133(DS)	1	223280	
PCB3	D922 or	DIODE	1SS133	(1)	223163	
PCB3	D922 or	DIODE	1SS270A	(1)	223205	
PCB3	D923	DIODE	1SS133(DS)	1	223280	
PCB3	D923 or	DIODE	1SS133	(1)	223163	
PCB3	D923 or	DIODE	1SS270A	(1)	223205	
PCB3	D924	DIODE	1SS133(DS)	1	223280	
PCB3	D924 or	DIODE	1SS133	(1)	223163	
PCB3	D924 or	DIODE	1SS270A	(1)	223205	
PCB3	D925	DIODE	1SS133(DS)	1	223280	
PCB3	D925 or	DIODE	1SS133	(1)	223163	
PCB3	D925 or	DIODE	1SS270A	(1)	223205	
PCB3	D930	DIODE	1SS133(DS)	1	223280	
PCB3	D930 or	DIODE	1SS133	(1)	223163	
PCB3	D930 or	DIODE	1SS270A	(1)	223205	
PCB3	D931	DIODE	1SS133(DS)	1	223280	
PCB3	D931 or	DIODE	1SS133	(1)	223163	
PCB3	D931 or	DIODE	1SS270A	(1)	223205	
PCB3	D932	DIODE	1SS133(DS)	1	223280	
PCB3	D932 or	DIODE	1SS133	(1)	223163	
PCB3	D932 or	DIODE	1SS270A	(1)	223205	
PCB3	D933	DIODE	1SS133(DS)	1	223280	
PCB3	D933 or	DIODE	1SS133	(1)	223163	
PCB3	D933 or	DIODE	1SS270A	(1)	223205	

PCB3	D934	ZENER D	DZ-5.1BSB	1	224850512	<DD, DC>
PCB3	D934 or	ZENER D	MTZJ5.1B	(1)	224470512	<DD, DC>
PCB3	D934	DIODE	1SS133(DS)	1	223280	<WT>
PCB3	D934 or	DIODE	1SS133	(1)	223163	<WT>
PCB3	D934 or	DIODE	1SS270A	(1)	223205	<WT>
PCB3	D934	ZENER D	DZ-5.1BSB	1	224850512	<PP>
PCB3	D934 or	ZENER D	MTZJ5.1B	(1)	224470512	<PP>
PCB3	D935	DIODE	1SS133(DS)	1	223280	
PCB3	D935 or	DIODE	1SS133	(1)	223163	
PCB3	D935 or	DIODE	1SS270A	(1)	223205	
PCB3	D1001	DIODE	1SS133(DS)	1	223280	
PCB3	D1001 or	DIODE	1SS133	(1)	223163	
PCB3	D1001 or	DIODE	1SS270A	(1)	223205	
PCB3	D1002	DIODE	1SS133(DS)	1	223280	
PCB3	D1002 or	DIODE	1SS133	(1)	223163	
PCB3	D1002 or	DIODE	1SS270A	(1)	223205	
PCB3	D5000	ZENER D	DZ-5.6BSB	1	224850562	
PCB3	D5000 or	ZENER D	MTZJ5.6B	(1)	224470562	
PCB3	D5001	ZENER D	DZ-5.6BSB	1	224850562	
PCB3	D5001 or	ZENER D	MTZJ5.6B	(1)	224470562	
PCB3	D5002	ZENER D	DZ-5.6BSB	1	224850562	
PCB3	D5002 or	ZENER D	MTZJ5.6B	(1)	224470562	
PCB3	D5003	ZENER D	DZ-5.6BSB	1	224850562	
PCB3	D5003 or	ZENER D	MTZJ5.6B	(1)	224470562	
PCB3	D5004	ZENER D	DZ-5.6BSB	1	224850562	
PCB3	D5004 or	ZENER D	MTZJ5.6B	(1)	224470562	
PCB3	D5005	ZENER D	DZ-5.6BSB	1	224850562	
PCB3	D5005 or	ZENER D	MTZJ5.6B	(1)	224470562	
PCB3	D6600	DIODE	1SS133(DS)	1	223280	
PCB3	D6600 or	DIODE	1SS133	(1)	223163	
PCB3	D6600 or	DIODE	1SS270A	(1)	223205	
PCB3	D6602	DIODE	1SS133(DS)	1	223280	
PCB3	D6602 or	DIODE	1SS133	(1)	223163	
PCB3	D6602 or	DIODE	1SS270A	(1)	223205	
PCB3	D6603	DIODE	1SS133(DS)	1	223280	
PCB3	D6603 or	DIODE	1SS133	(1)	223163	
PCB3	D6603 or	DIODE	1SS270A	(1)	223205	
PCB3	D6605	DIODE	1SS133(DS)	1	223280	
PCB3	D6605 or	DIODE	1SS133	(1)	223163	
PCB3	D6605 or	DIODE	1SS270A	(1)	223205	
PCB3	D6607	DIODE	1SS133(DS)	1	223280	
PCB3	D6607 or	DIODE	1SS133	(1)	223163	
PCB3	D6607 or	DIODE	1SS270A	(1)	223205	
PCB3	D9001	DIODE	RL1N4003	1	22380260	
PCB3	D9001 or	DIODE	GP104003E	(1)	22380035	
PCB3	D9002	DIODE	RL1N4003	1	22380260	
PCB3	D9002 or	DIODE	GP104003E	(1)	22380035	
PCB3	D9003	DIODE	RL1N4003	1	22380260	
PCB3	D9003 or	DIODE	GP104003E	(1)	22380035	
PCB3	D9004	DIODE	RL1N4003	1	22380260	
PCB3	D9004 or	DIODE	GP104003E	(1)	22380035	

PCB3	D9009	DIODE	RL1N4003	1	22380260	
PCB3	D9009 or	DIODE	GP104003E	(1)	22380035	
PCB3	D9012	ZENER D	DZ-36BSD	1	224853604	
PCB3	D9012 or	ZENER D	MTZJ36D	(1)	224473604	
PCB3	D9013	DIODE	RL1N4003	1	22380260	
PCB3	D9013 or	DIODE	GP104003E	(1)	22380035	
PCB3	D9022	DIODE	1SS133(DS)	1	223280	<WT>
PCB3	D9022 or	DIODE	1SS133	(1)	223163	<WT>
PCB3	D9022 or	DIODE	1SS270A	(1)	223205	<WT>
PCB3	D9023	DIODE	1SS133(DS)	1	223280	<WT>
PCB3	D9023 or	DIODE	1SS133	(1)	223163	<WT>
PCB3	D9023 or	DIODE	1SS270A	(1)	223205	<WT>
PCB3	D9024	DIODE	1SS133(DS)	1	223280	<WT>
PCB3	D9024 or	DIODE	1SS133	(1)	223163	<WT>
PCB3	D9024 or	DIODE	1SS270A	(1)	223205	<WT>
PCB3	D9025	DIODE	1SS133(DS)	1	223280	<WT>
PCB3	D9025 or	DIODE	1SS133	(1)	223163	<WT>
PCB3	D9025 or	DIODE	1SS270A	(1)	223205	<WT>
PCB3	D9026	ZENER D	MTZJ12C	1	224471203	<WT>
PCB3	D9026 or	ZENER D	DZ-12BSC	(1)	224851203	<WT>
PCB3	D9027	DIODE	1SS133(DS)	1	223280	<WT>
PCB3	D9027 or	DIODE	1SS133	(1)	223163	<WT>
PCB3	D9027 or	DIODE	1SS270A	(1)	223205	<WT>
PCB3	D9705	DIODE	1SS133(DS)	1	223280	
PCB3	D9705 or	DIODE	1SS133	(1)	223163	
PCB3	D9705 or	DIODE	1SS270A	(1)	223205	
PCB3	D9706	DIODE	1SS133(DS)	1	223280	
PCB3	D9706 or	DIODE	1SS133	(1)	223163	
PCB3	D9706 or	DIODE	1SS270A	(1)	223205	
PCB3	T902	P TRANS	NPT-1520JQ	1	2301812	!, <DD, DC>
PCB3	T902	P TRANS	NPT-1519JQ	1	2301810	!, <WT>
PCB3	T902	P TRANS	NPT-1519GQ	1	2301811	!, <PP>
PCB3	L6600	S COIL	S-1.3C	1	231176S	<WT>
PCB3	L6600	S COIL	S-1.3C	1	231176S	<PP>
PCB3	L6601	S COIL	S-1.3C	1	231176S	<WT>
PCB3	L6601	S COIL	S-1.3C	1	231176S	<PP>
PCB3	L6602	S COIL	S-1.3C	1	231176S	<WT>
PCB3	L6602	S COIL	S-1.3C	1	231176S	<PP>
PCB3	L6603	S COIL	S-1.3C	1	231176S	<WT>
PCB3	L6603	S COIL	S-1.3C	1	231176S	<PP>
PCB3	L6604	S COIL	S-1.3C	1	231176S	<WT>
PCB3	L6604	S COIL	S-1.3C	1	231176S	<PP>
PCB3	L6605	S COIL	S-1.3C	1	231176S	<WT>
PCB3	L6605	S COIL	S-1.3C	1	231176S	<PP>
PCB3	C901	IS C	ECQU2A103MLC	1	3800039S	!
PCB3	C901 or	IS C	RE275V-103M	(1)	3500196S	!
PCB3	C901 or	IS C	LE103-C3.5	(1)	3800042S	!
PCB3	C921	CERA C	CK45F50V-223Z	1	335622230	
PCB3	C922	VR C	CE04W25V-2200M(VR)	1	394652227S	
PCB3	C930	VR C	CE04W35V-100M(VR)	1	394661017	
PCB3	C931	VX C	CE04W50V-10M(VX)	1	393381007	<WT>

PCB3	C932	VR C	CE04W16V-100M(VR)	1	394641017	<WT>
PCB3	C933	VR C	CE04W50V-4.7M(VR)	1	394680477	
PCB3	C1001	VR C	CE04W50V-2.2M(VR)	1	394680227	
PCB3	C1002	VR C	CE04W50V-2.2M(VR)	1	394680227	
PCB3	C1003	VR C	CE04W16V-470M(VR)	1	394644717	
PCB3	C1004	VR C	CE04W50V-2.2M(VR)	1	394680227	
PCB3	C1005	VR C	CE04W16V-470M(VR)	1	394644717	
PCB3	C1017	VR C	CE04W50V-2.2M(VR)	1	394680227	
PCB3	C1020	CERA C	CK45F50V-223Z	1	335622230	
PCB3	C1023	VR C	CE04W25V-47M(VR)	1	394654707	
PCB3	C1024	CERA C	CK45F50V-223Z	1	335622230	
PCB3	C1032	CERA C	CK45F50V-223Z	1	335622230	
PCB3	C5000	TF C	ECQ-B50V-101K	1	374721015	
PCB3	C5001	TF C	ECQ-B50V-101K	1	374721015	
PCB3	C5002	TF C	ECQ-B50V-101K	1	374721015	
PCB3	C5003	TF C	ECQ-B50V-101K	1	374721015	
PCB3	C5004	TF C	ECQ-B50V-101K	1	374721015	
PCB3	C5005	TF C	ECQ-B50V-101K	1	374721015	
PCB3	C5010	VX C	CE04W50V-47M(VX)	1	393384707	
PCB3	C5011	VX C	CE04W50V-47M(VX)	1	393384707	
PCB3	C5012	VX C	CE04W50V-10M(VX)	1	393381007	
PCB3	C5013	VX C	CE04W50V-10M(VX)	1	393381007	
PCB3	C5014	VX C	CE04W50V-10M(VX)	1	393381007	
PCB3	C5015	VX C	CE04W50V-10M(VX)	1	393381007	
PCB3	C5020	VX C	CE04W50V-10M(VX)	1	393381007	
PCB3	C5021	VX C	CE04W50V-10M(VX)	1	393381007	
PCB3	C5022	VX C	CE04W50V-10M(VX)	1	393381007	
PCB3	C5023	VX C	CE04W50V-10M(VX)	1	393381007	
PCB3	C5024	VX C	CE04W50V-10M(VX)	1	393381007	
PCB3	C5025	VX C	CE04W50V-10M(VX)	1	393381007	
PCB3	C5040	VX C	CE04W25V-220M(VX)	1	393352217	
PCB3	C5041	VX C	CE04W25V-220M(VX)	1	393352217	
PCB3	C5042	VX C	CE04W25V-220M(VX)	1	393352217	
PCB3	C5043	VX C	CE04W25V-220M(VX)	1	393352217	
PCB3	C5044	VX C	CE04W25V-220M(VX)	1	393352217	
PCB3	C5045	VX C	CE04W25V-220M(VX)	1	393352217	
PCB3	C5050	VX C	CE04W50V-47M(VX)	1	393384707	
PCB3	C5051	VX C	CE04W50V-47M(VX)	1	393384707	
PCB3	C5052	VX C	CE04W50V-47M(VX)	1	393384707	
PCB3	C5053	VX C	CE04W50V-47M(VX)	1	393384707	
PCB3	C5054	VX C	CE04W50V-47M(VX)	1	393384707	
PCB3	C5055	VX C	CE04W50V-47M(VX)	1	393384707	
PCB3	C5080	CERA C	CC45SL50V-040C	1	345020401	
PCB3	C5081	CERA C	CC45SL50V-040C	1	345020401	
PCB3	C5082	CERA C	CC45SL50V-040C	1	345020401	
PCB3	C5083	CERA C	CC45SL50V-040C	1	345020401	
PCB3	C5084	CERA C	CC45SL50V-040C	1	345020401	
PCB3	C5085	CERA C	CC45SL50V-040C	1	345020401	
PCB3	C5090	TF C	ECQ-B50V-101K	1	374721015	
PCB3	C5091	TF C	ECQ-B50V-101K	1	374721015	
PCB3	C5092	TF C	ECQ-B50V-101K	1	374721015	

PCB3	C5093	TF C	ECQ-B50V-101K	1	374721015	
PCB3	C5094	TF C	ECQ-B50V-101K	1	374721015	
PCB3	C5095	TF C	ECQ-B50V-101K	1	374721015	
PCB3	C5100	VR C	CE04W63V-10M(VR)	1	394671007	
PCB3	C5101	VR C	CE04W63V-10M(VR)	1	394671007	
PCB3	C5102	VR C	CE04W63V-10M(VR)	1	394671007	
PCB3	C5103	VR C	CE04W63V-10M(VR)	1	394671007	
PCB3	C5104	VR C	CE04W63V-10M(VR)	1	394671007	
PCB3	C5105	VR C	CE04W63V-10M(VR)	1	394671007	
PCB3	C5110	VR C	CE04W63V-10M(VR)	1	394671007	
PCB3	C5111	VR C	CE04W63V-10M(VR)	1	394671007	
PCB3	C5112	VR C	CE04W63V-10M(VR)	1	394671007	
PCB3	C5113	VR C	CE04W63V-10M(VR)	1	394671007	
PCB3	C5114	VR C	CE04W63V-10M(VR)	1	394671007	
PCB3	C5115	VR C	CE04W63V-10M(VR)	1	394671007	
PCB3	C6600	TF C	ECQ-B50V-103J	1	374721034	
PCB3	C6602	TF C	ECQ-B50V-103J	1	374721034	
PCB3	C6603	CERA C	CK45F50V-103Z	1	335621030	
PCB3	C6605	CERA C	CK45F50V-103Z	1	335621030	
PCB3	C6607	CERA C	CK45F50V-103Z	1	335621030	
PCB3	C6640	TF C	ECQ-B50V-103J	1	374721034	<WT>
PCB3	C6640	TF C	ECQ-B50V-103J	1	374721034	<PP>
PCB3	C6641	TF C	ECQ-B50V-103J	1	374721034	<WT>
PCB3	C6641	TF C	ECQ-B50V-103J	1	374721034	<PP>
PCB3	C6642	TF C	ECQ-B50V-103J	1	374721034	<WT>
PCB3	C6642	TF C	ECQ-B50V-103J	1	374721034	<PP>
PCB3	C6643	TF C	ECQ-B50V-103J	1	374721034	<WT>
PCB3	C6643	TF C	ECQ-B50V-103J	1	374721034	<PP>
PCB3	C6644	TF C	ECQ-B50V-103J	1	374721034	<WT>
PCB3	C6644	TF C	ECQ-B50V-103J	1	374721034	<PP>
PCB3	C6645	TF C	ECQ-B50V-103J	1	374721034	<WT>
PCB3	C6645	TF C	ECQ-B50V-103J	1	374721034	<PP>
PCB3	C6647	TF C	ECQ-B50V-103J	1	374721034	<WT>
PCB3	C6647	TF C	ECQ-B50V-103J	1	374721034	<PP>
PCB3	C6648	TF C	ECQ-B50V-103J	1	374721034	<WT>
PCB3	C6648	TF C	ECQ-B50V-103J	1	374721034	<PP>
PCB3	C6650	CERA C	CK45B50V-102K	1	335321025	<WT>
PCB3	C6650	CERA C	CK45B50V-102K	1	335321025	<PP>
PCB3	C6651	CERA C	CK45B50V-102K	1	335321025	<WT>
PCB3	C6651	CERA C	CK45B50V-102K	1	335321025	<PP>
PCB3	C6652	CERA C	CK45B50V-102K	1	335321025	<WT>
PCB3	C6652	CERA C	CK45B50V-102K	1	335321025	<PP>
PCB3	C6653	CERA C	CK45B50V-102K	1	335321025	<WT>
PCB3	C6653	CERA C	CK45B50V-102K	1	335321025	<PP>
PCB3	C6654	CERA C	CK45B50V-102K	1	335321025	<WT>
PCB3	C6654	CERA C	CK45B50V-102K	1	335321025	<PP>
PCB3	C6655	CERA C	CK45B50V-102K	1	335321025	<WT>
PCB3	C6655	CERA C	CK45B50V-102K	1	335321025	<PP>
PCB3	C6657	CERA C	CK45B50V-102K	1	335321025	<WT>
PCB3	C6657	CERA C	CK45B50V-102K	1	335321025	<PP>
PCB3	C6658	CERA C	CK45B50V-102K	1	335321025	<WT>

PCB3	C6658	CERA C	CK45B50V-102K	1	335321025	<PP>
PCB3	C9001	MMT C	MMT50V-334J	1	375523344	
PCB3	C9003	VR C	CE04W35V-1000M(VR)	1	394661027S	
PCB3	C9004	VR C	CE04W35V-470M(VR)	1	394664717	
PCB3	C9009	VR C	CE04W35V-220M(VR)	1	394662217	
PCB3	C9014	VR C	CE04W63V-470M(VR)	1	394674717S	
PCB3	C9015	VX C	CE04W50V-10M(VX)	1	393381007	
PCB3	C9016	VX C	CE04W50V-10M(VX)	1	393381007	
PCB3	C9021	VX C	CE04W50V-10M(VX)	1	393381007	<WT>
PCB3	C9591	MMT C	MMT50V-104J	1	375521044	
PCB3	C9708	CERA C	CK45B50V-222K	1	335322225	
PCB3	R922	CARBON R	R16J-10K	1	417341034	
PCB3	R923	CARBON R	R16J-1K	1	417341024	
PCB3	R930	CARBON R	R16J-100K	1	417341044	<WT>
PCB3	R931	CARBON R	R16J-100K	1	417341044	<WT>
PCB3	R932	CARBON R	R16J-82K	1	417348234	<WT>
PCB3	R933	CARBON R	R16J-10K	1	417341034	<WT>
PCB3	R934	CARBON R	R16J-100K	1	417341044	
PCB3	R1001	CARBON R	R16J-75	1	417347504	
PCB3	R1002	CARBON R	R16J-75	1	417347504	
PCB3	R1003	CARBON R	R16J-75	1	417347504	
PCB3	R1004	CARBON R	R16J-100K	1	417341044	
PCB3	R1005	CARBON R	R16J-75	1	417347504	
PCB3	R1006	CARBON R	R16J-75	1	417347504	
PCB3	R1007	CARBON R	R16J-680K	1	417346844	
PCB3	R1008	CARBON R	R16J-680K	1	417346844	
PCB3	R1009	CARBON R	R16J-680K	1	417346844	
PCB3	R1010	CARBON R	R16J-220	1	417342214	
PCB3	R1023	CARBON R	R16J-100K	1	417341044	
PCB3	R1024	CARBON R	R16J-100K	1	417341044	
PCB3	R1030	CARBON R	R16J-680K	1	417346844	
PCB3	R1031	CARBON R	R16J-75	1	417347504	
PCB3	R5000	CARBON R	R16J-1K	1	417341024	
PCB3	R5001	CARBON R	R16J-1K	1	417341024	
PCB3	R5002	CARBON R	R16J-1K	1	417341024	
PCB3	R5003	CARBON R	R16J-1K	1	417341024	
PCB3	R5004	CARBON R	R16J-1K	1	417341024	
PCB3	R5005	CARBON R	R16J-1K	1	417341024	
PCB3	R5010	CARBON R	R16J-56K	1	417345634	
PCB3	R5011	CARBON R	R16J-56K	1	417345634	
PCB3	R5012	CARBON R	R16J-56K	1	417345634	
PCB3	R5013	CARBON R	R16J-56K	1	417345634	
PCB3	R5014	CARBON R	R16J-56K	1	417345634	
PCB3	R5015	CARBON R	R16J-56K	1	417345634	
PCB3	R5020	CARBON R	R16J-330	1	417343314	
PCB3	R5021	CARBON R	R16J-330	1	417343314	
PCB3	R5022	CARBON R	R16J-330	1	417343314	
PCB3	R5023	CARBON R	R16J-330	1	417343314	
PCB3	R5024	CARBON R	R16J-330	1	417343314	
PCB3	R5025	CARBON R	R16J-330	1	417343314	
PCB3	R5030	CARBON R	R16J-120K	1	417341244	

PCB3	R5031	CARBON R	R16J-120K	1	417341244
PCB3	R5032	CARBON R	R16J-120K	1	417341244
PCB3	R5033	CARBON R	R16J-120K	1	417341244
PCB3	R5034	CARBON R	R16J-120K	1	417341244
PCB3	R5035	CARBON R	R16J-120K	1	417341244
PCB3	R5040	CARBON R	R16J-2.2K	1	417342224
PCB3	R5041	CARBON R	R16J-2.2K	1	417342224
PCB3	R5042	CARBON R	R16J-2.2K	1	417342224
PCB3	R5043	CARBON R	R16J-2.2K	1	417342224
PCB3	R5044	CARBON R	R16J-2.2K	1	417342224
PCB3	R5045	CARBON R	R16J-2.2K	1	417342224
PCB3	R5050	CARBON R	R16J-4.7K	1	417344724
PCB3	R5051	CARBON R	R16J-4.7K	1	417344724
PCB3	R5052	CARBON R	R16J-4.7K	1	417344724
PCB3	R5053	CARBON R	R16J-4.7K	1	417344724
PCB3	R5054	CARBON R	R16J-4.7K	1	417344724
PCB3	R5055	CARBON R	R16J-4.7K	1	417344724
PCB3	R5060	CARBON R	R16J-1.2K	1	417341224
PCB3	R5061	CARBON R	R16J-1.2K	1	417341224
PCB3	R5062	CARBON R	R16J-1.2K	1	417341224
PCB3	R5063	CARBON R	R16J-1.2K	1	417341224
PCB3	R5064	CARBON R	R16J-1.2K	1	417341224
PCB3	R5065	CARBON R	R16J-1.2K	1	417341224
PCB3	R5080	CARBON R	R16J-470	1	417344714
PCB3	R5081	CARBON R	R16J-470	1	417344714
PCB3	R5082	CARBON R	R16J-470	1	417344714
PCB3	R5083	CARBON R	R16J-470	1	417344714
PCB3	R5084	CARBON R	R16J-470	1	417344714
PCB3	R5085	CARBON R	R16J-470	1	417344714
PCB3	R5090	CARBON R	R16J-100K	1	417341044
PCB3	R5091	CARBON R	R16J-100K	1	417341044
PCB3	R5092	CARBON R	R16J-100K	1	417341044
PCB3	R5093	CARBON R	R16J-100K	1	417341044
PCB3	R5094	CARBON R	R16J-100K	1	417341044
PCB3	R5095	CARBON R	R16J-100K	1	417341044
PCB3	R5100	CARBON R	R16J-100K	1	417341044
PCB3	R5101	CARBON R	R16J-100K	1	417341044
PCB3	R5102	CARBON R	R16J-100K	1	417341044
PCB3	R5103	CARBON R	R16J-100K	1	417341044
PCB3	R5104	CARBON R	R16J-100K	1	417341044
PCB3	R5105	CARBON R	R16J-100K	1	417341044
PCB3	R5110	CARBON R	R16J-1K	1	417341024
PCB3	R5111	CARBON R	R16J-1K	1	417341024
PCB3	R5112	CARBON R	R16J-1K	1	417341024
PCB3	R5113	CARBON R	R16J-1K	1	417341024
PCB3	R5114	CARBON R	R16J-1K	1	417341024
PCB3	R5115	CARBON R	R16J-1K	1	417341024
PCB3	R5130	CARBON R	R16J-22K	1	417342234
PCB3	R5131	CARBON R	R16J-22K	1	417342234
PCB3	R5132	CARBON R	R16J-18K	1	417341834
PCB3	R5133	CARBON R	R16J-18K	1	417341834

PCB3	R5134	CARBON R	R16J-18K	1	417341834	
PCB3	R5135	CARBON R	R16J-18K	1	417341834	
PCB3	R5160	NF CARBON R	R25J-100	1	415471014	
PCB3	R5161	NF CARBON R	R25J-100	1	415471014	
PCB3	R5162	NF CARBON R	R25J-100	1	415471014	
PCB3	R5163	NF CARBON R	R25J-100	1	415471014	
PCB3	R5164	NF CARBON R	R25J-100	1	415471014	
PCB3	R5165	NF CARBON R	R25J-100	1	415471014	
PCB3	R5170	NF CARBON R	R25J-100	1	415471014	
PCB3	R5171	NF CARBON R	R25J-100	1	415471014	
PCB3	R5172	NF CARBON R	R25J-100	1	415471014	
PCB3	R5173	NF CARBON R	R25J-100	1	415471014	
PCB3	R5174	NF CARBON R	R25J-100	1	415471014	
PCB3	R5175	NF CARBON R	R25J-100	1	415471014	
PCB3	R5180	NF CARBON R	R25J-10	1	415471004	
PCB3	R5181	NF CARBON R	R25J-10	1	415471004	
PCB3	R5182	NF CARBON R	R25J-10	1	415471004	
PCB3	R5183	NF CARBON R	R25J-10	1	415471004	
PCB3	R5184	NF CARBON R	R25J-10	1	415471004	
PCB3	R5185	NF CARBON R	R25J-10	1	415471004	
PCB3	R5190	NF CARBON R	R25J-10	1	415471004	
PCB3	R5191	NF CARBON R	R25J-10	1	415471004	
PCB3	R5192	NF CARBON R	R25J-10	1	415471004	
PCB3	R5193	NF CARBON R	R25J-10	1	415471004	
PCB3	R5194	NF CARBON R	R25J-10	1	415471004	
PCB3	R5195	NF CARBON R	R25J-10	1	415471004	
PCB3	R5200	CARBON R	R16J-22K	1	417342234	
PCB3	R5201	CARBON R	R16J-22K	1	417342234	
PCB3	R5230	CARBON R	R16J-120K	1	417341244	
PCB3	R5231	CARBON R	R16J-120K	1	417341244	
PCB3	R5232	CARBON R	R16J-120K	1	417341244	
PCB3	R5233	CARBON R	R16J-120K	1	417341244	
PCB3	R5234	CARBON R	R16J-120K	1	417341244	
PCB3	R5235	CARBON R	R16J-120K	1	417341244	
PCB3	R6600	CARBON R	R16J-22	1	417342204	<WT>
PCB3	R6600	CARBON R	R16J-22	1	417342204	<PP>
PCB3	R6601	CARBON R	R16J-22	1	417342204	<WT>
PCB3	R6601	CARBON R	R16J-22	1	417342204	<PP>
PCB3	R6602	CARBON R	R16J-22	1	417342204	<WT>
PCB3	R6602	CARBON R	R16J-22	1	417342204	<PP>
PCB3	R6603	CARBON R	R16J-22	1	417342204	<WT>
PCB3	R6603	CARBON R	R16J-22	1	417342204	<PP>
PCB3	R6604	CARBON R	R16J-22	1	417342204	<WT>
PCB3	R6604	CARBON R	R16J-22	1	417342204	<PP>
PCB3	R6605	CARBON R	R16J-22	1	417342204	<WT>
PCB3	R6605	CARBON R	R16J-22	1	417342204	<PP>
PCB3	R6610	CARBON R	R16J-22	1	417342204	<WT>
PCB3	R6610	CARBON R	R16J-22	1	417342204	<PP>
PCB3	R6611	CARBON R	R16J-22	1	417342204	<WT>
PCB3	R6611	CARBON R	R16J-22	1	417342204	<PP>
PCB3	R6612	CARBON R	R16J-22	1	417342204	<WT>

PCB3	R6612	CARBON R	R16J-22	1	417342204	<PP>
PCB3	R6613	CARBON R	R16J-22	1	417342204	<WT>
PCB3	R6613	CARBON R	R16J-22	1	417342204	<PP>
PCB3	R6614	CARBON R	R16J-22	1	417342204	<WT>
PCB3	R6614	CARBON R	R16J-22	1	417342204	<PP>
PCB3	R6615	CARBON R	R16J-22	1	417342204	<WT>
PCB3	R6615	CARBON R	R16J-22	1	417342204	<PP>
PCB3	R6690	METAL O R	RS1/2WBJ-10	1	443521004	
PCB3	R9002	METAL O R	RS1/2WBJ-22	1	443522204	
PCB3	R9003	CARBON R	R16J-8.2K	1	417348224	
PCB3	R9004	CARBON R	R16J-8.2K	1	417348224	
PCB3	R9005	CARBON R	R16J-330K	1	417343344	
PCB3	R9022	CARBON R	R16J-10K	1	417341034	<WT>
PCB3	R9023	CARBON R	R16J-10K	1	417341034	<WT>
PCB3	R9024	CARBON R	R16J-3.3K	1	417343324	<WT>
PCB3	R9025	CARBON R	R16J-100K	1	417341044	<WT>
PCB3	R9591	METAL R	RNU1/2WCJ-0.47	1	453534794	!
PCB3	R9592	METAL R	RNU1/2WCJ-0.47	1	453534794	!
PCB3	R9593	METAL R	RNU1/2WCJ-0.22	1	453532294	!
PCB3	R9594	METAL R	RNU1/2WCJ-8.2	1	453530824	!
PCB3	RL6600	RELAY	NRL-2P5A-DC24-158	1	25065618	
PCB3	RL6600 or	RELAY	NRL-2P5A-DC24-129	(1)	25065563	
PCB3	RL6602	RELAY	NRL-2P5A-DC24-158	1	25065618	
PCB3	RL6602 or	RELAY	NRL-2P5A-DC24-129	(1)	25065563	
PCB3	RL6603	RELAY	NRL-2P5A-DC24-158	1	25065618	
PCB3	RL6603 or	RELAY	NRL-2P5A-DC24-129	(1)	25065563	
PCB3	RL6605	RELAY	NRL-2P5A-DC24-158	1	25065618	
PCB3	RL6605 or	RELAY	NRL-2P5A-DC24-129	(1)	25065563	
PCB3	RL6607	RELAY	NRL-2P5A-DC24-158	1	25065618	
PCB3	RL6607 or	RELAY	NRL-2P5A-DC24-129	(1)	25065563	
PCB3	RL901	RELAY	NRL-1P5A-DC9-179	1	25065669	!
PCB3	S902	SLIDE SW	NSS-22157P	1	25065437	!, <WT>
PCB3	P901A	PLUG	NPLG-2P631	1	25055675	!
PCB3	P901A or	PLUG	1-1123724-2	(1)	25056402	!
PCB3	P909	TRM(SCREW)	NEGITANSI M3	1	25065425	<DD, DC>
PCB3	P909	TRM(SCREW)	NEGITANSI M3	1	25065425	<PP>
PCB3	P912	PLUG	NPLG-2P631	1	25055675	!, <DD, DC>
PCB3	P912 or	PLUG	1-1123724-2	(1)	25056402	!, <DD, DC>
PCB3	P912	PLUG	B5P9-VH	1	25056568	!, <WT>
PCB3	P912	PLUG	NPLG-2P631	1	25055675	!, <PP>
PCB3	P912 or	PLUG	1-1123724-2	(1)	25056402	!, <PP>
PCB3	P931A	PLUG	NPLG-5P0960	1	25056010	
PCB3	P931B	SOCKET	NSCT-5P2185	1	25052288	
PCB3	P1001	PIN JACK	NPJ-3PDYYY560	1	25045778	
PCB3	P1001 or	PIN JACK	NPJ-3PDYE158	(1)	25045299	
PCB3	P1002	PIN JACK	NPJ-3PDYYY560	1	25045778	
PCB3	P1002 or	PIN JACK	NPJ-3PDYE158	(1)	25045299	
PCB3	P1088	TRM(SCREW)	NEGITANSI M3	1	25065425	
PCB3	P1089	TRM(SCREW)	NEGITANSI M3	1	25065425	
PCB3	P2005A	SOCKET	NSCT-13P2193	1	25052296	
PCB3	P5019	TRM(SCREW)	NEGITANSI M3	1	25065425	

PCB3	P5504A	PLUG	NPLG-13P141	1	25055157	
PCB3	P6000A	SOCKET	NSCT-5P2185	1	25052288	
PCB3	P6001A	SOCKET	NSCT-5P2185	1	25052288	
PCB3	P6002A	SOCKET	NSCT-5P2185	1	25052288	
PCB3	P6003A	SOCKET	NSCT-5P2185	1	25052288	
PCB3	P6004A	SOCKET	NSCT-5P2185	1	25052288	
PCB3	P6005A	SOCKET	NSCT-5P2185	1	25052288	
PCB3	P6011B	RETAINER	(BUS)	1	27141965	
PCB3	P6011C	TAPE	TAPE(CLOTH-16U)	(1)	29110083	
PCB3	P6600	TRM	NTM-12PDML356	1	25060427	
PCB3	P6600 or	TRM	NTM-12PDML362	(1)	25060433	
PCB3	P6607	TRM	NTM-4PDML357	1	25060428	
PCB3	P6607 or	TRM	NTM-4PDML364	(1)	25060435	
PCB3	P6690	TRM(SCREW)	NEGITANSI M3	1	25065425	
PCB3	P9002	TRM(SCREW)	NEGITANSI M3	1	25065425	
PCB3	P9502A	PLUG	14R-FJ	1	25056566	
PCB3	E9001	RETAINER	KANAGU	1	27141059	
PCB3	F901A	FUSE HOL	NSCT-1P2031	1	25052133	!, <DD, DC>
PCB3	F901A	FUSE HOL	NSCT-1P2031	1	25052133	!, <WT>
PCB3	F901B	FUSE HOL	NSCT-1P2031	1	25052133	!, <DD, DC>
PCB3	F901B	FUSE HOL	NSCT-1P2031	1	25052133	!, <WT>
PCB3	F902A	FUSE HOL	NSCT-1P2031	1	25052133	!, <WT>
PCB3	F902A	FUSE HOL	NSCT-1P2031	1	25052133	!, <PP>
PCB3	F902B	FUSE HOL	NSCT-1P2031	1	25052133	!, <WT>
PCB3	F902B	FUSE HOL	NSCT-1P2031	1	25052133	!, <PP>
PCB3	JL2006A	WIRE HOL	NSCT-5P896	1	25051109	
PCB3	JL2006B	SOCKET	NSCT-5P97	1	25050269	
PCB3	JL6600B	SOCKET	NSCT-7P99	1	25050271	
PCB3	JL6603B	SOCKET	NSCT-9P101	1	25050273	
PCB3	JL9501A	WIRE HOL	NSCT-7P898	1	25051111	
PCB3	JL9501B	WIRE HOL	NSCT-7P898	1	25051111	