

# SCHEMA DE PRINCIPE T 151

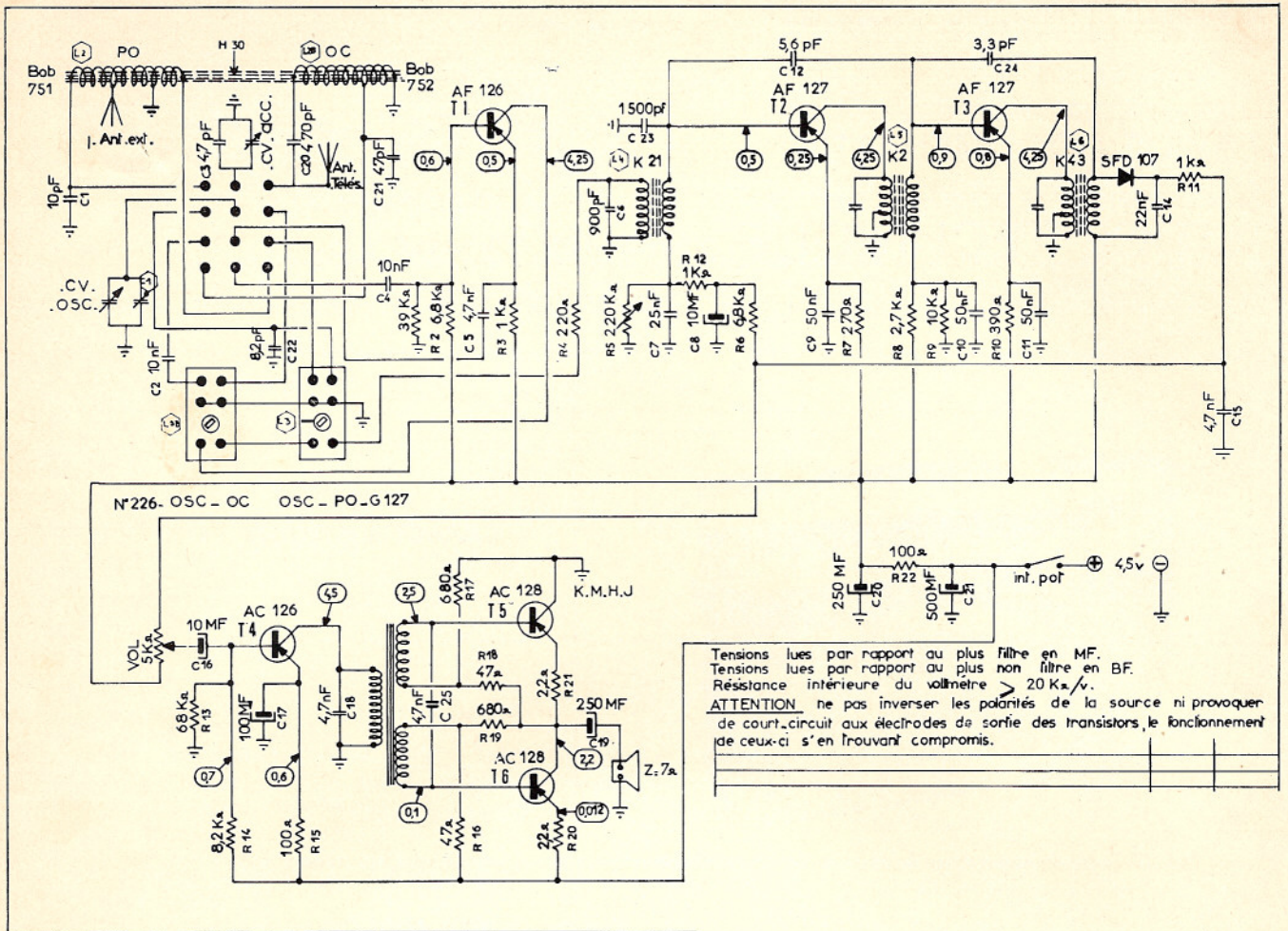

## MONTAGE DE L'ENTRAINEMENT T 151

