

GRUNDIG

Model 200

General Description : Four-valve (plus two transistors), three-wave-band, all-dry battery, portable receiver with push-pull transistor output stage and push-button band selection. A ferrite-rod aerial is incorporated and provision is made for an external aerial to be connected.

Power Supplies : H.T. (valve) 67.5 volts; L.T. 6 volts. The 6-volt battery also provides power for the transistors, and the current will vary between 30 mA. and 100 mA. with output. H.T. consumption about 3.4 mA.

Wavebands : L.W.; M.W.; S.W. (5.5-16 Mcs.).

Valves : (V1) DK96; (V2) DF96; (V3) DAF96; (V4) DF97.

Transistors : Two type OC72.

Circuit Notes : The first three stages are that of a conventional battery portable. The DK96 is the mixer-oscillator, having L1 and L2 as its aerial coupling coils and L3, L4 and L5 as its R.F. coils for S.W., M.W. and L.W. respectively. L1, L2, L3, L4 and L5 are all mounted on a common ferrite rod. L6, L7 and L8 are the oscillator coils for S.W., M.W. and L.W. respectively.

From the DK96 the I.F. signal (468 kc/s.) is fed to the DF96, the I.F. amplifier, and from there to the DAF96, the signal detector and A.F. amplifier. A.G.C. voltage is fed back from this stage to the previous two stages. The volume control, R19, is in the grid of the A.F. amplifier, and the tone control, R23, is in series with a 700-pF. capacitor from anode to chassis.

The output from the DAF96 is fed via C41 to the grid of the DF97, a pentode strapped as a triode, which is the driver stage for the two transistors. T3 is the driver transformer with C45 across its primary affording a certain measure of top cut.

The two junction transistors are wired in a grounded-emitter circuit with R35, R33, R34 and R32 forming the bias network. R34 is a thermistor to stabilise the bias in case of a rise in temperature, thus preventing an increase of current passed by the transistors and hence "thermal runaway". The driver transformer feeds the two transistor bases, and the output is taken from the two collectors. A negative feedback loop is taken from the secondary of the output transformer to the grid of the DF97. The loud-speaker is a high-flux, permanent-magnet 6-in. elliptical type.

C46 minimises the effect of a rising battery impedance as its voltage drops.

Transistor Bias Adjustment : With no signal input and tuning capacitor fully enmeshed, insert a D.C. meter into the primary centre tap of the output transformer and adjust R32 for a reading of 1.7 mA.

Alignment Procedure : Figures in brackets refer to adjustment points indicated in trimmer and core lay-out diagram. *I.F.* : Remove A.G.C. by disconnecting one end of R17. Inject a 468-kc/s. signal to grid of V2.

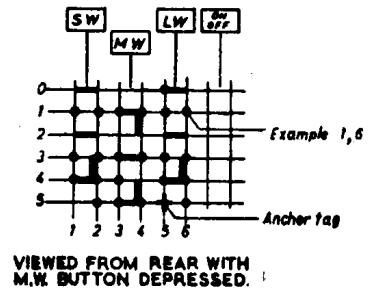
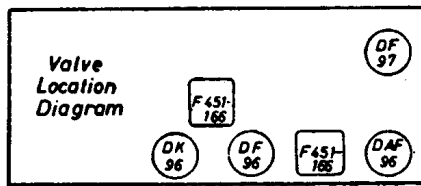
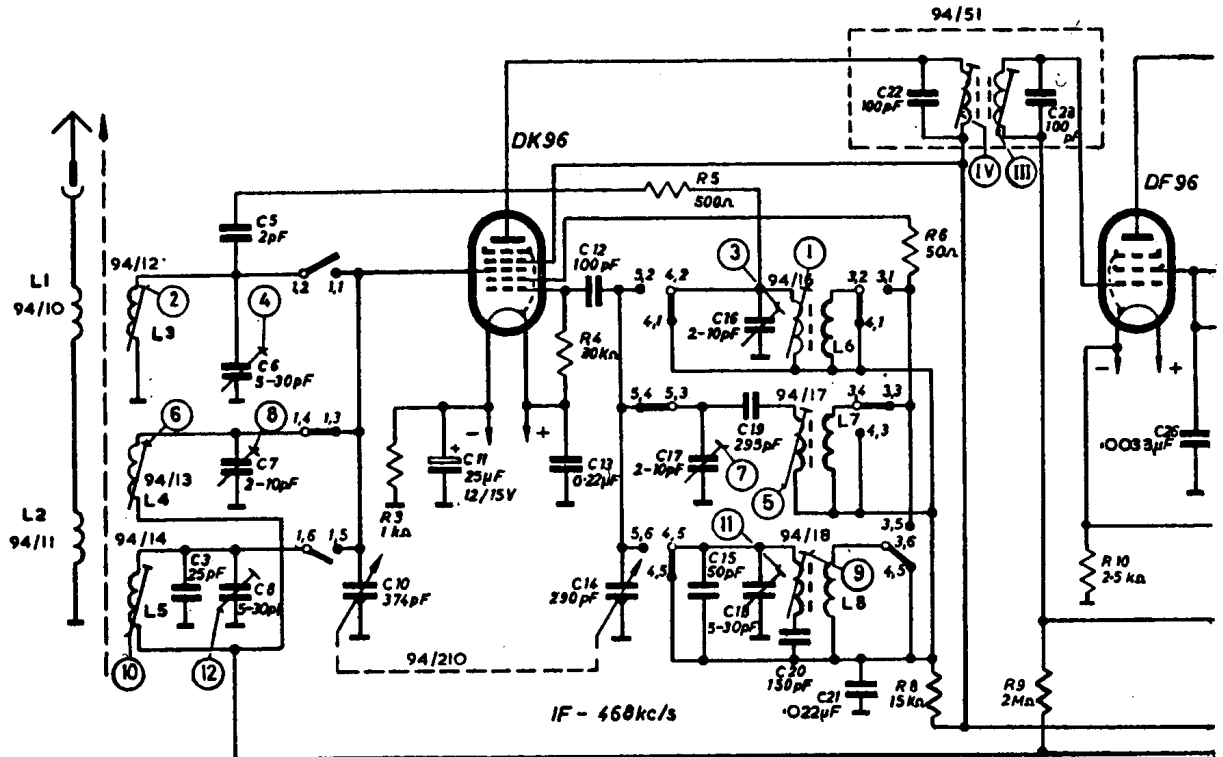

CIRCUIT DIAGRAM—

Adjust (I) and (II) for maximum. Inject signal to signal grid of V_I and adjust cores (III) and (IV) for maximum.

R.F. : Inject signals to aerial socket. Adjustments for max. output.

S.W. : Tune generator and set to 6.7 Mc/s. Adjust coils (1) and (2). Tune generator and set to 15.25 Mc/s. Adjust trimmers (3) and (4).

M.W. : Tune to 560 kc/s. and adjust coils (5) and (6). Tune to 1500 kc/s. and adjust trimmers (7) and (8).

L.W. : Tune to 162 kc/s. and adjust coils (9) and (10). Tune to 320 kc/s. and adjust trimmers (11) and (12).

Note : Repeat operations for each band, always finishing with adjustment of trimmers. Finally, reconnect R₁₇.

Voltage Checks : The voltage and current measurements shown on the valve base diagram are taken in M.W. position under "no signal" conditions (tuning gang fully enmeshed).

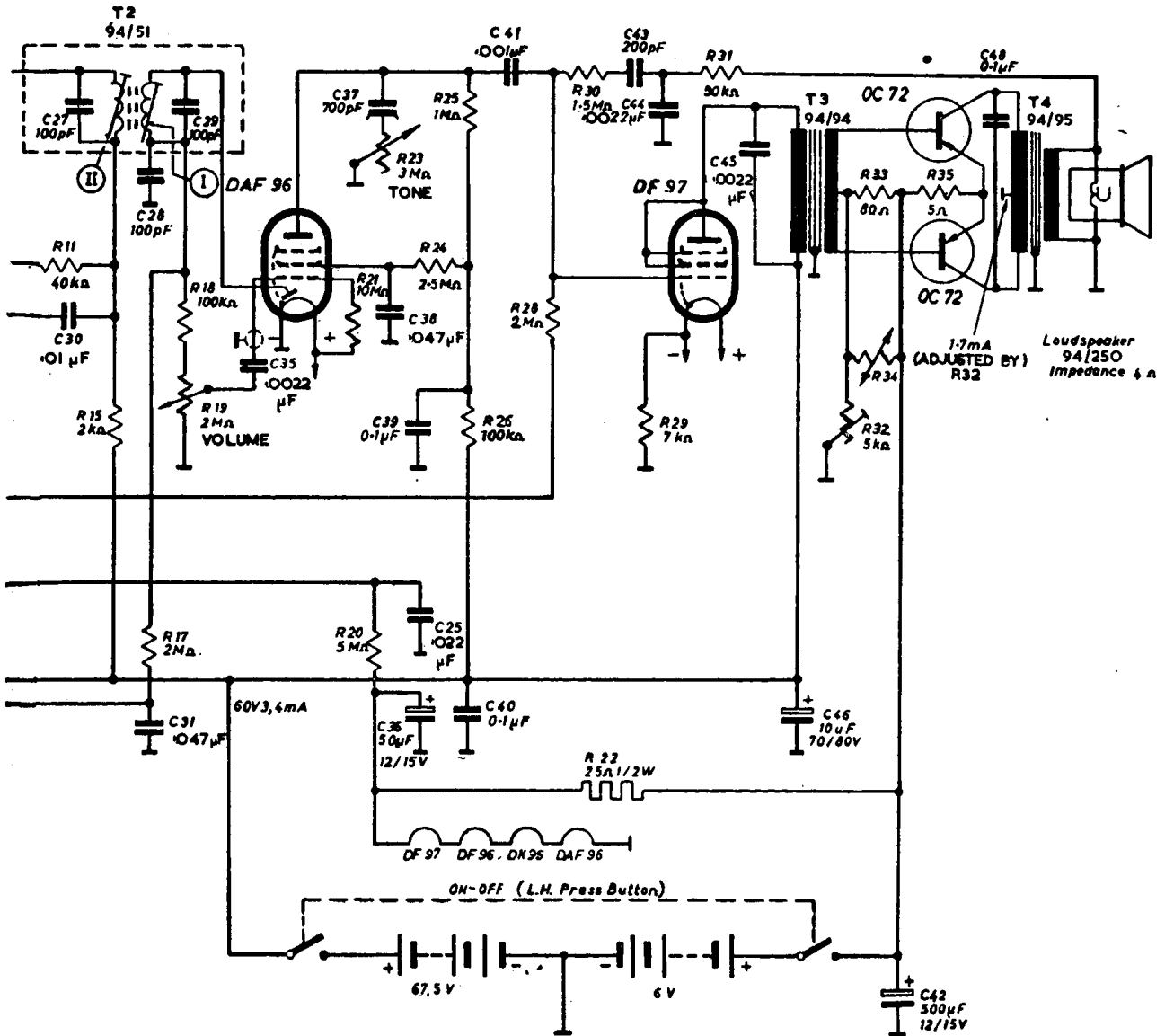

GRUNDIG TRANSISTORISED PORTABLE MODEL 200

(Right) CORE AND TRIMMER LOCATIONS. (Below) BASE CONNECTIONS AND VALVE ANALYSIS

