

INSTRUCTION MANUAL FT-101ZD

For Service Manuals Contact
MAURITRON TECHNICAL SERVICES
8 Cherry Tree Rd, Chinnor
Oxon OX9 4QY
Tel: 01844-351694 Fax: 01844-352554
Email: enquiries@mauritron.co.uk

YASU MUSEN CO., LTD.

TOKYO JAPAN

TABLE CONTENTS

| | (Page) |
|--------------------------------|--------|
| GENERAL DESCRIPTION | 1 |
| SPECIFICATIONS | 2 |
| TUBES AND SEMICONDUCTORS | 3 |
| CONTROLS AND SWITCHES | 4 |
| REAR APRON CONNECTIONS..... | 7 |
| ACCESSORIES | 8 |
| INSTALLATION | 10 |
| OPERATION | 12 |
| BLOCK DIAGRAM..... | 21 |
| CIRCUIT DESCRIPTION..... | 22 |
| MAINTENANCE AND ALIGNMENT..... | 34 |
| PARTS LIST | 43 |

HIGH—PERFORMANCE HF TRANSCEIVER YAESU FT-101ZD

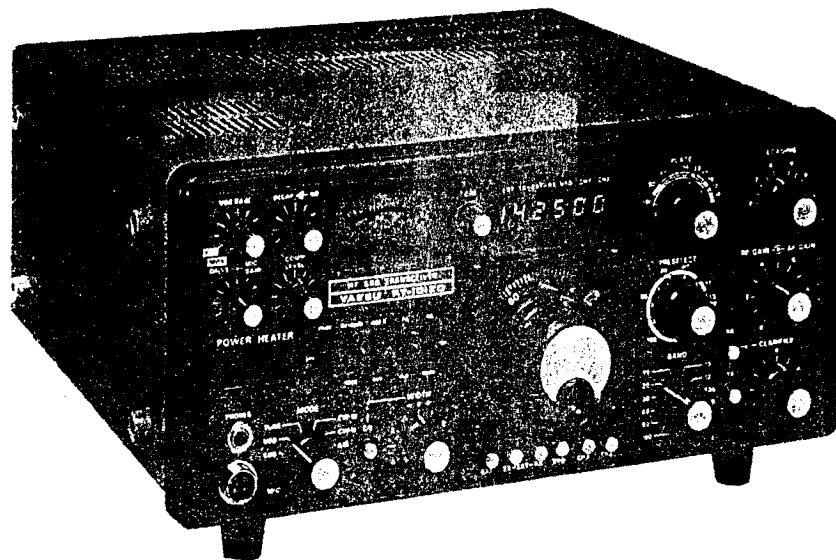

GENERAL DESCRIPTION

The FT-101ZD is a precision engineered, high-performance HF transceiver of advanced design, providing all band (160 - 10 meters) operation on SSB, CW, and AM. This transceiver operates at an input power of 180 watts.

Advanced features include digital plus analog frequency display, continuously variable IF bandwidth (300 Hz - 2.4 kHz), a superb noise blanker with threshold adjustment, and an effective RF speech processor. The receiver boasts excellent dynamic range, despite its high sensitivity, for reliable operation in the presence of strong signals.

Built into every FT-101ZD are VOX, semi-break-in CW with sidetone, a 25 kHz crystal calibrator, selectable AGC, and a 10 dB/20 dB RF attenuator in the incoming signal path.

The FT-101ZD has been engineered for use. Controls and switches are laid out in an efficient and logical manner, so you won't have to fumble for a switch or knob when you need it quickly. And Yaesu designers have now made it possible for you to switch sidebands without recalibrating the display.

All circuits, except the transmitter driver and final amplifier stages, are solid state. Solid state devices provide extremely high reliability and high component density, along with low power drain. The FT-101ZD may be operated from a variety of AC voltages, from 100 to 234 volts. A DC-DC converter, providing operation from a 13.5 VDC power source, is an available option.

For the economy FT-101Z, the counter unit is an available option, providing digital display capability should you want to upgrade your transceiver at a later date. Optional equipment on both models FT-101ZD and FT-101Z are the cooling fan, DC-DC converter, 600 Hz CW filter, and microphone.

A diecast front panel, and the heavy-duty case, provide maximum protection for your transceiver. If the ratings of this unit are not exceeded, it will provide the owner with many years of satisfying operation. Please read this manual carefully before commencing operation, in order to derive maximum satisfaction from your new YAESU transceiver.

SPECIFICATIONS

Frequency coverage:

| | |
|-------|-----------------|
| 160 m | 1.8 - 2.0 MHz |
| 80 m | 3.5 - 4.0 MHz |
| 40 m | 7.0 - 7.5 MHz |
| 30 m | 10.0 - 10.5 MHz |
| 20 m | 14.0 - 14.5 MHz |
| 17 m | 18.0 - 18.5 MHz |
| 15 m | 21.0 - 21.5 MHz |
| 12 m | 24.5 - 25.0 MHz |
| 10 m | 28.0 - 29.9 MHz |

Power requirements:

| | |
|----|--|
| AC | 100/110/117/200/220/234 volts, 50/60 Hz |
| DC | 13.5 volts \pm 10% (DC-DC converter optional) |

Power consumption:

| | |
|----|---|
| AC | 85 VA receive (73 VA HEATER OFF) 330 VA transmit |
| DC | 5.5 amps receive (1.1 amps HEATER OFF) 21 amps transmit |

Size:

345 (W) x 157 (H) x 326 (D) mm

Weight:

Approx. 15 kg.

TRANSMITTER

Emission type:

LSB, USB, CW, AM.

Power input:

180 watts DC (SSB, CW)
50 watts DC (AM)

Carrier suppression:

Better than 40 dB

Unwanted sideband suppression:

Better than 40 dB (14 MHz, 1 kHz)

Spurious radiation:

Better than 40 dB down

Transmitter frequency response:

300 - 2700 Hz (-6 dB)

Third order distortion products:

Better than 31 dB down

Transmitter frequency stability:

Less than 300 Hz after 10 minute warmup;
less than 100 Hz after 30 minute warmup.

Antenna output impedance:

50 - 75 ohms, unbalanced

Microphone input impedance:

500 - 600 ohms (low impedance)

RECEIVER

Sensitivity:

0.25 μ V for S/N 10 dB (SSB, CW)
0.5 μ V for S/N 10 dB (AM)

Image rejection:

Better than 60 dB (160 - 12 m)
Better than 50 dB (10 m)

IF rejection:

Better than 70 dB (160, 80, 20.- 10 m)
Better than 60 dB (40 m, 30.m)

Selectivity:

SSB, AM 2.4 kHz at 6 dB down, 4.0 kHz at
60 dB down
CW (with optional CW filter) 600 Hz at 6 dB
down, 1.2 kHz at 60 dB down

Bandwidth control:

Continuous from 2.4 kHz to 300 Hz

Audio output impedance:

4 - 16 ohms

Audio output:

3 watts at 10% THD, 4 ohm load

Specifications subject to change without notice.

For Service Manuals Contact
MAURITRON TECHNICAL SERVICES
8 Cherry Tree Rd, Chinnor
Oxon OX9 4QY
Tel:- 01844-351694 Fax:- 01844-352554
Email:- enquiries@mauritron.co.uk

TUBES AND SEMICONDUCTORS

Vacuum Tubes

12BY7A 1
6146B 2

Transistors

T20A6 2
2SA495 1
2SA496Y 2
2SA564A 3
2SA639 1
2SA733 1
2SA952LB 14
2SB616 1
2SC372Y 15
2SC373 1
2SC380TMY 15
2SC535A 1
2SC732TMGR 1
2SC1000GR 2
2SC1383 1
2SC1583 2
2SC1674 1
2SC1815GR 1
2SC1815Y 6
2SC2407 2
MPSA13 1

Field Effect Transistors

2SK19GR 8
2SK19BL 1
3SK40M 1
3SK51-03 7
3SK73 1
J310 2

Integrated Circuits (IC)

μ PA54H 1
 μ PC7505H 1
 μ PC78L12 1
 μ PC14308 1
 μ PC2002H 1
MC3403P 1
MC14024B 1
MSM9520RS 1
NJM78L05 1
SN76514N 1
SN74LS123N 1
TA7060P 1
TA7063P 1

Germanium Diodes

1N60 11
1S1007 (GB) 12

Silicon Diodes

1S1555 65
10D1 7
10D10 8
V06B 2
1SS53 25

Schottky Barrier Diode

ND487C2-3R 1
(Ring Module)

Zener Diodes

WZ061 1
WZ090 2

Varactor Diodes

1S2209 1
1S2236 1
FC63 1

Light Emitting Diodes

GD4-203SRD 9

LED Display

HP-5082-7623 6

FT-101ZD SERIES MODEL CHART

○ = BUILT-IN FEATURE X = AVAILABLE OPTION

| FEATURE | FT-101ZD | FT-101Z |
|-------------------|----------|---------|
| ALL BAND CRYSTALS | ○ | ○ |
| COUNTER UNIT | ○ | X |
| DC-DC CONVERTER | X | X |
| CW FILTER | X | X |
| MICROPHONE | X | X |
| RF PROCESSOR | ○ | ○ |
| COOLING FAN | X | X |

CONTROLS AND SWITCHES

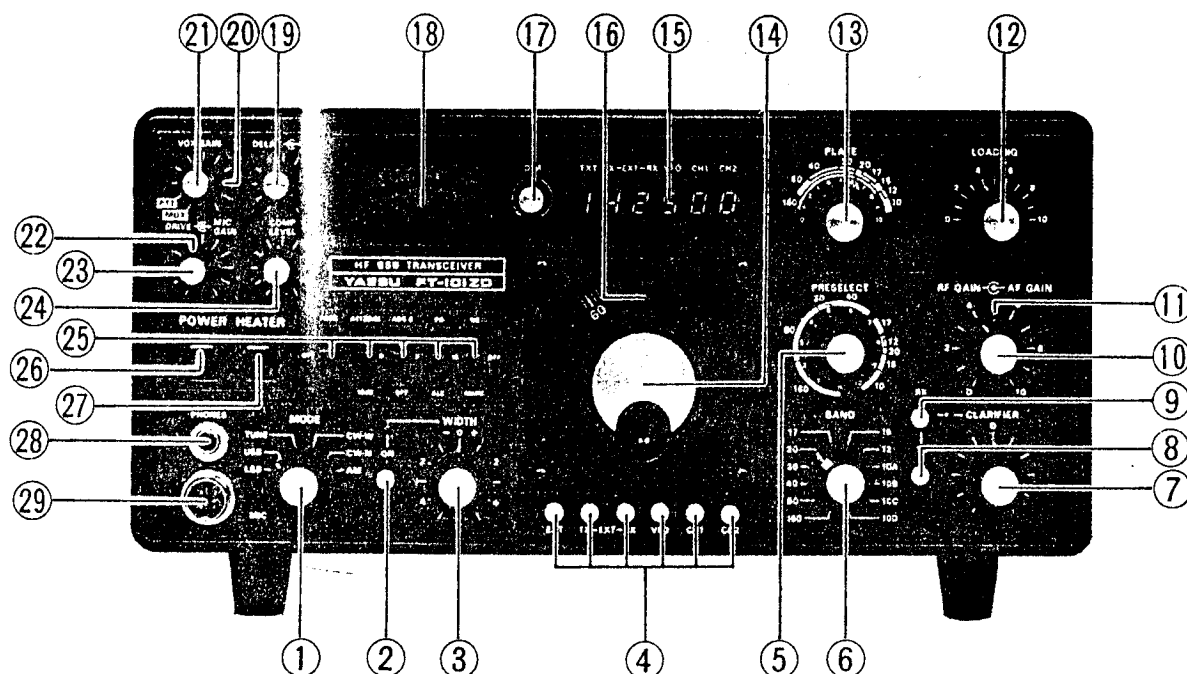

(1) MODE

Selection of LSB, USB, CW-W (SSB filter), CW-N (optional CW filter) and AM is provided.

(2) WIDTH ON

When this button is pressed, the variable bandwidth function is activated.

(3) WIDTH

This control varies the IF bandwidth from 2.4 kHz down to 300 Hz. When the WIDTH switch is OFF, the bandwidth is fixed by the filter selected at the MODE switch.

(4) SELECT switches

When using the optional FV-901DM synthesized, scanning external VFO, these switches determine which component will control the transmit, receive, or transceive frequency.

EXT..... This switch, when pressed, shifts control of the transceive frequency to the external VFO.

TX EXT... This switch, when pressed, shifts control of the transmit frequency to the external VFO.

RX EXT... This switch, when pressed, shifts control of the receive frequency to the external VFO.

VFO..... This switch selects control of the transceive frequency on the FT-101ZD internal VFO.

CH1, CH2. . These switches select optional fixed channels, transceive only.

(5) PRESELECT

The preselector control peaks the RF and IF stages for the frequency in use.

(6) BAND

The bandswitch selects the frequency band in use: 160 - 10 meters.

(7) CLARIFIER

The clarifier control allows offset of ± 2.5 kHz from the frequency established by the main tuning dial.

(8) (9) CLARIFIER SELECT switches

Press the RX button for offset of the receive frequency.

Press the TX button for offset of the transmit frequency.

Press both buttons for offset of the transceive frequency.

(10) AF GAIN

The AF GAIN control varies the output level of the audio amplifier stages. Clockwise rotation increases the audio output level.

(11) RF GAIN

The RF GAIN control varies the gain of the RF and IF stages. Clockwise rotation increases the gain of these stages.

(12) LOADING

This control tunes the output circuit of the final amplifier pi network to match the feedpoint impedance of the load.

(13) PLATE

This control tunes the plate circuit of the final amplifier.

(14) MAIN TUNING KNOB

Rotation of this knob selects the operating frequency, in conjunction with the setting of the bandswitch. One revolution of the dial produces a frequency change of approximately 17 kHz.

(15) DIGITAL DISPLAY

The digital display reads out the operating frequency, with resolution to 100 Hz. The display unit is built into the FT-101ZD, and is an available option for the FT-101Z.

(16) ANALOG DIAL

The analog dial allows readout of the operating frequency to better than 1 kHz. The combination of the precision dial mechanism and drive unit provides zero backlash at slow tuning rates.

(17) DIM

This control allows dimming of the meter and dial lamps.

(18) METER

The meter displays final amplifier cathode current (IC), relative power output (PO), and ALC feedback voltage.

(19) NB

This control varies the threshold point for the noise blanker, and should be set to the minimum point that provides the desired blanking action.

(20) DELAY

This control sets the delay time for the VOX relay. For voice-actuated SSB, or semi-break-in CW, the operator may select the delay time most suitable for his or her operating habits.

(21) VOX GAIN

The threshold level for the VOX (voice operated relay) system can be varied using this control. In the PTT position, PTT (push to talk) control is provided, for relay control via the microphone PTT switch or footswitch.

(22) DRIVE

This control sets the carrier level for CW/AM and tuning purposes. When the RF processor is ON, this control varies the RF output on SSB, as well.

(23) MIC GAIN

This control sets the output level of the microphone amplifier stage. Clockwise rotation increases the mic gain level.

(24) COMP LEVEL

This control varies the compression level for the built-in RF speech processor. The processor does not function in the AM mode.

(25) FUNCTION switches

PROC This switch activates the RF speech processor.

ATT This switch allows the insertion of 10 or 20 dB attenuators in the incoming signal path.

AGC S/F/OFF . . This switch allows selection of the desired AGC decay time. In the OFF position, the AGC is switched off, and the S-meter will not function.

PO/IC/ALC In the PO position, relative power output is displayed on the meter. In the IC position, final amplifier cathode current is displayed. In the ALC position, ALC voltage is displayed. Regardless of the setting of the meter switch, the meter functions as an S-meter on receive.

NB/MARK In the NB position, the noise blanker is activated. In the MARK position, the internal crystal calibrator is activated.

(26) POWER

This is the main ON/OFF switch for the transceiver.

(27) HEATER

With the HEATER switch on, heater voltage is applied to the driver and final amplifier tubes. This switch may be turned off during periods of RX, when energy conservation is critical.

(28) PHONES

This is a standard 1/4" phone jack for use with headphones.

(29) MIC

This is a 4 conductor jack for microphone and PTT input.

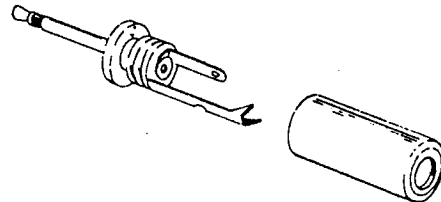
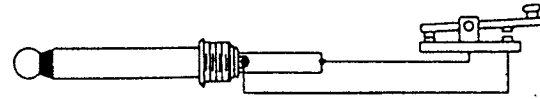

Key plug

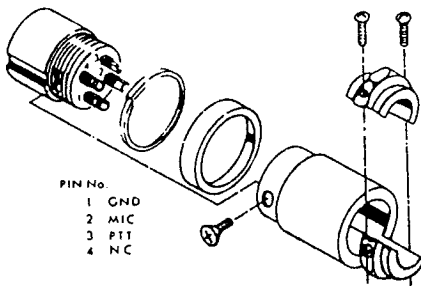
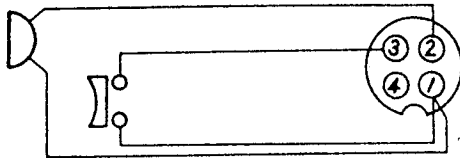

Mic plug

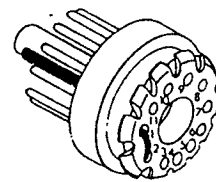

| PIN No. | Function |
|---------|----------|
| 1 | HEATER |
| 2 | HEATER |
| 3 | +100V |
| 4 | +300V |
| 5 | +800V |
| 6 | -100V |
| 7 | AIC |
| 8 | GND |
| 9 | PTT GND |
| 10 | PTT GND |
| 11 | NC |

ACC plug

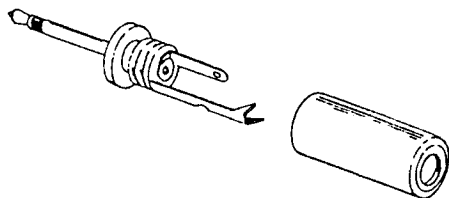
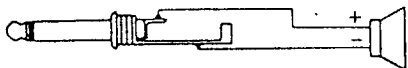
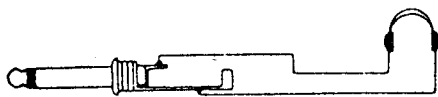

Headphone and external speaker plug

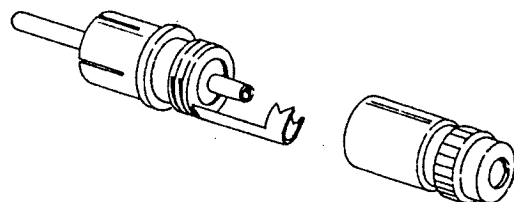
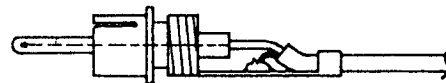

Pin plug

REAR APRON

For Service Manuals Contact
MAURITRON TECHNICAL SERVICES
8 Cherry Tree Rd, Chinnor
Oxon OX9 4QY
Tel: 01844-351694 Fax: 01844-352554
Email: enquiries@mauritron.co.uk

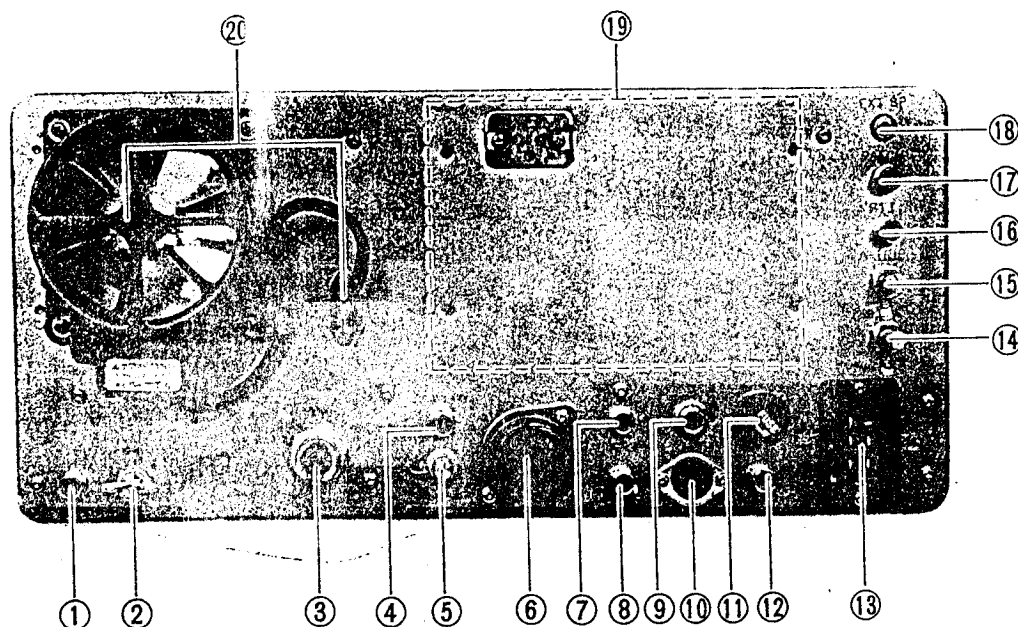

(1) RF OUT

RF output of 3 volts RMS is available at this jack for use with a transverter. Output is from the driver stage.

(2) GND

For best transceiver performance, as well as protection from electrical shock, a good ground connection should be made at this point, using a heavy, braided wire of the shortest length possible.

(3) ANT

Standard "UHF" connector for the antenna.

(4) RCV ANT

This jack is switched in parallel with the ANT jack on receive, for use with an external receiver.

(5) PO ADJ

This control adjusts the relative power output meter.

(6) ACC

Transceiver operating voltages and relay connections can be accessed through the accessory jack. Please insert the ACC plug at all times, to provide heater voltage for the driver and final amplifier tubes.

(7) TONE OUT

The CW sidetone may be fed to an external receiver through this jack.

(8) A TRIP IN

Anti-trip input from an external receiver may be made via this jack, to prevent the receiver audio output from tripping the FT-101ZD VOX.

(9) KEY

The CW key may be connected at this point. Key-up voltage is 7 volts, and key-down current is 1.5 mA. Be sure your electronic keyer's output switch will handle these levels.

(10) EXT VFO

Connection of an external VFO, such as the FV-101Z or FV-901DM, can be made at this jack.

(11) FUSE

This is the fuse holder. For 100 - 117 volts, replace with only a 5 amp fuse. For 200 - 234 volts, use a 3 amp fuse. Replace fuses only with a fuse of the proper rating.

(12) IF OUT

Wideband IF output is available at this jack for use with a spectrum analyzer, etc.

(13) POWER

Connect the AC power cord at this point, being certain that your AC supply voltage matches the voltage specification for your transceiver. See the transformer primary connection chart. When using the optional DC-DC converter, the DC supply is connected at this point. **DO NOT CONNECT THE AC POWER CORD TO A DC POWER SOURCE. OUR WARRANTY DOES NOT COVER DAMAGE CAUSED BY SUCH IMPROPER POWER CONNECTIONS.**

(14) TONE

This control varies the CW sidetone output level.

(15) A TRIP

This control varies the level of the VOX anti-trip circuit.

(16) PTT

External control of the transceiver PTT (push to talk) system may be made at this jack, for use with a footswitch, etc.

(17) PATCH

Microphone or phone patch input may be made at this jack. Impedance is 500 ohms.

(18) EXT SP

This is a miniature phone jack for speaker output. When a plug is inserted into this jack, the transceiver internal speaker will be cut off. Impedance is 4 - 16 ohms.

(19) DC-DC CONVERTER (OPTION)

The optional DC-DC converter allows operation from a 13.5 volt DC power source.

(20) COOLING FAN (OPTION)

The optional cooling fan keeps the tubes at a safe operating temperature, when they are used in a hot environment. The 2 pin fan power jack supplies 100 volts to the fan.

ACCESSORIES

The following accessories are included with your new transceiver:

(1) AC POWER CORD 1

The power cord comes equipped with a 6-prong connector for connection to the AC supply.

(2) ACC PLUG 1

The accessory plug allows access to relay contacts and transceiver operating voltages. The ACC plug must be inserted in the accessory socket for proper operation of the transceiver, whether or not external connections are being made.

(3) PHONO PLUG 2

Use these plugs for interface with station equipment via the FT-101ZD rear panel.

(4) SPARE FUSES 5A (3A) 1 each

When replacing fuses, be absolutely certain to use a fuse of the proper rating. **OUR WARRANTY DOES NOT COVER DAMAGE CAUSED BY IMPROPER FUSE REPLACEMENT.** For 100 - 117 volt AC operation, use a 5 amp fuse. For 200 - 234 volt operation, use a 3 amp fuse.

INTERCONNECTIONS

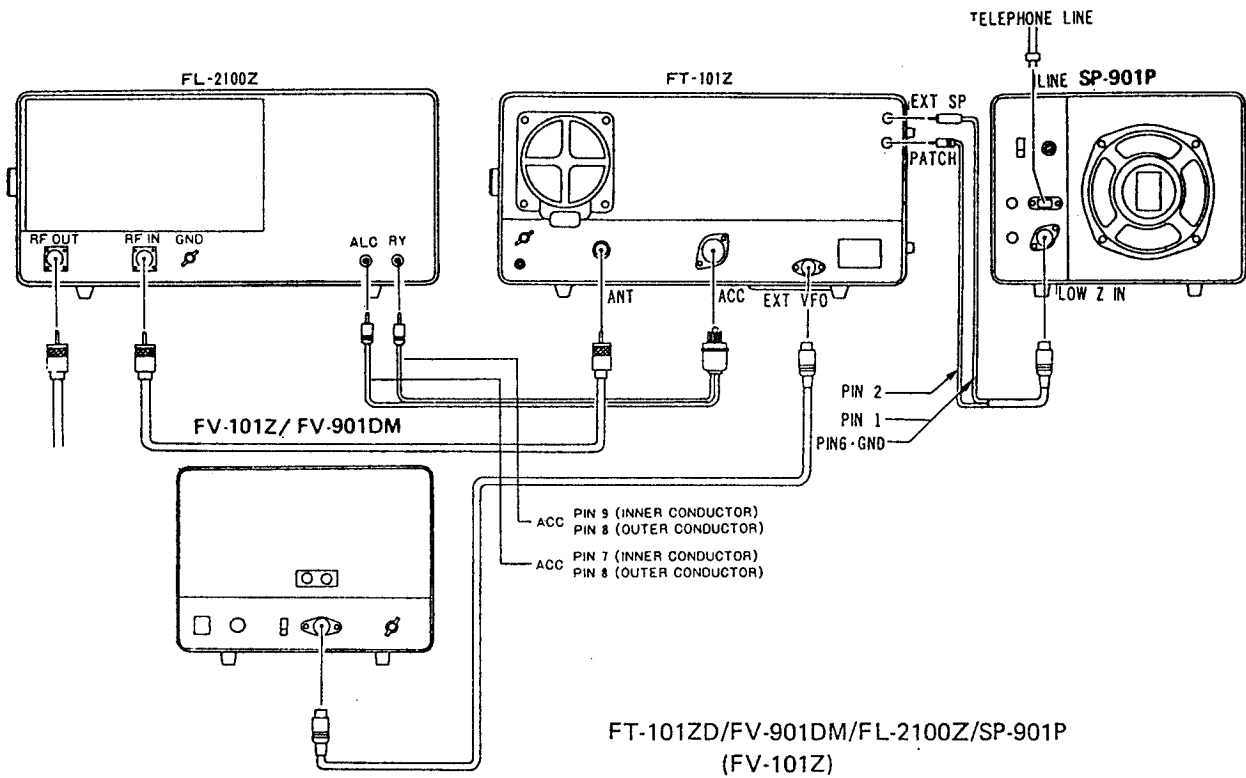

For Service Manuals Contact
MAURITRON TECHNICAL SERVICES
 8 Cherry Tree Rd, Chinnor
 Oxon OX9 4QY
 Tel: 01844-351694 Fax: 01844-352554
 Email: enquiries@mauritron.co.uk

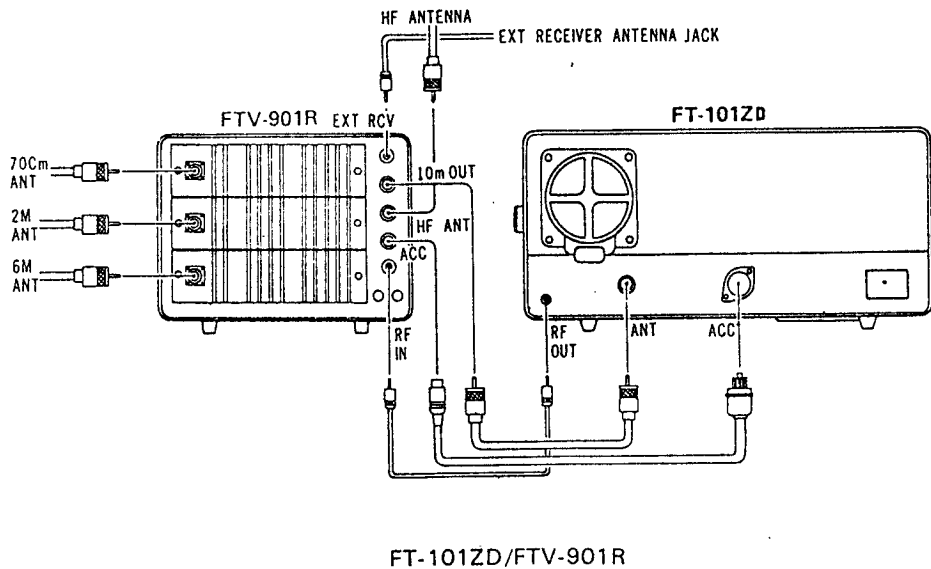

INSTALLATION

The FT-101ZD is designed to be a single-unit station for fixed or portable operation from AC power. Power supply connections providing for operation from a variety of source voltages are available. Please read the following sections carefully, so as to ensure proper installation of your new transceiver.

PRELIMINARY INSPECTION

Upon opening the packing carton, immediately give the transceiver a thorough visual inspection. Check to see that all controls and switches are working freely, and inspect the cabinet for any signs of damage. If any damage has been sustained, immediately contact the shipping company, and document the damage completely. Save the packing carton and foam packing material for possible use at a later date.

BASE STATION INSTALLATION

The FT-101ZD is designed for use in many areas of the world, using supply voltages that may differ from your local supply voltage. For this reason, be absolutely certain that the voltage specification marked on the rear of the transceiver agrees with the local AC supply voltage. **THIS INSPECTION MUST BE MADE BEFORE CONNECTING THE AC POWER CORD TO THE REAR APRON OF THE TRANSCEIVER.**

CAUTION

PERMANENT DAMAGE WILL RESULT IF IMPROPER AC SUPPLY VOLTAGE IS APPLIED TO THE TRANSCEIVER. OUR WARRANTY DOES NOT COVER DAMAGE CAUSED BY APPLICATION OF IMPROPER SUPPLY VOLTAGE. DO NOT CONNECT THE AC POWER CORD TO A DC POWER SOURCE.

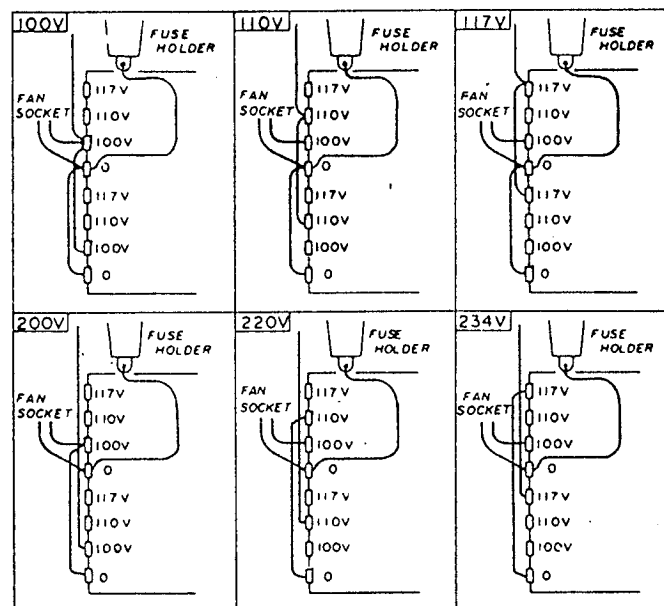

The transceiver should be connected to a good earth ground. The ground lead should be made of a heavy, braided wire, and should be connected to the GND terminal on the rear apron of the transceiver.

MOBILE INSTALLATION

(Note: The DC-DC converter described herein is optional equipment. See your Yaesu dealer.)

When the optional DC-DC converter is installed, the FT-101ZD will operate satisfactorily from a 13.5 volt DC power source capable of providing the required current. The DC power cord is included with the DC-DC converter kit.

For under-dash mobile mounting, a special mobile mounting bracket is an available option for your transceiver. The FT-101ZD should be located away from heater ducts, and a minimum of two inches of air space on all sides is recommended, to allow proper air flow around the cabinet. Never stack other units above or below the FT-101ZD, as the accumulated heat from both units could cause damage.

The transceiver requires an average of 14 amps on transmit, with 20 amps on voice peaks. The DC power cable comes equipped with a 20 amp fuse. Be certain to use only a 20 amp fuse when making replacement.

When making battery connections, be absolutely certain that the RED lead is connected to the POSITIVE battery terminal, and the BLACK lead is connected to the NEGATIVE battery terminal. Reversed connections could cause permanent damage to the transceiver. **OUR WARRANTY DOES NOT COVER DAMAGE CAUSED BY IMPROPER SUPPLY CONNECTIONS.**

It is recommended that the power connections be made directly to the battery, instead of to the ignition switch, etc. The battery provides considerable filtering action against ignition noise, and connection to the ignition switch can place the power line in a noisy circuit. Keep the power lead as short as possible, and keep the lead away from ignition cables.

Before connecting the DC power cable to the transceiver, check the battery voltage with the engine running (battery charging). If the voltage exceeds 15 volts DC, the vehicle voltage regulator should be adjusted, so as to limit the highest charging rate to less than 15 volts. As well, do not operate the transceiver if the DC supply voltage is less than 12 volts. The transceiver should always be turned off when the car is started, to prevent voltage transients from damaging the power supply components.

ANTENNA CONSIDERATIONS

The FT-101ZD is designed for use with an antenna system presenting a 50 - 75 ohm resistive load at the antenna jack. While the transmitter output circuitry is designed for uniform response within this impedance range, significant departures from the 50 - 75 ohm specification will result in seriously degraded transceiver performance, and may result in damage to the final amplifier tubes.

If an open-wire feedline is used, or if the input impedance of the antenna system presents a higher or lower impedance than specified, some sort of antenna tuner must be used to provide the proper impedance for the transceiver. See your Yaesu dealer for details of the FC-902 antenna coupler.

For mobile operation, most of the commercially-available antennas will provide satisfactory results, if care is taken to tune the antenna for minimum SWR. The outer conductor of the coaxial cable should be securely grounded to the automobile chassis at the antenna mount. See your Yaesu dealer for details on the RSL series of mobile antennas.

For Service Manuals Contact
MAURITRON TECHNICAL SERVICES
8 Cherry Tree Rd, Chinnor
Oxon OX9 4QY
Tel:- 01844-351694 Fax:- 01844-352554
Email:- enquiries@mauritron.co.uk

OPERATION

The tuning procedure for this transceiver is not complicated. However, care should be exercised when tuning so that peak performance of the equipment is secured. The following paragraphs describe the procedure for receiver and transmitter tuning.

INITIAL CHECK

Before connecting the transceiver to the power source, be certain that the voltage specification marked on the rear of the transceiver matches your local supply voltage, and also confirm that a fuse of the proper rating is being used.

FREQUENCY SELECTION

Frequency readout on the FT-101ZD is by digital as well as analog displays. The FT-101Z uses analog display only. The analog readout dial provides resolution to 1 kHz, while the FT-101ZD digital display provides resolution to 100 Hz. The digital display may be added to the FT-101Z as an option. See your Yaesu dealer for details.

RECEIVE OPERATION

- (1) Preset the controls and switches as follows:

POWER OFF
HEATER OFF
VFO Switch pushed
VOX GAIN . . . PTT position
RF GAIN Fully clockwise
AF GAIN Adjust later for comfortable level
BAND Desired band
MODE Desired mode
PRESELECT . . . Desired band segment
AGC OFF
ATT OFF
MARK/NB OFF

- (2) Turn the power switch to ON. The meter will light up, and the operating frequency will be displayed on the dial window (FT-101ZD). Adjust the AF GAIN control for a comfortable listening level, and adjust the PRESELECT control for maximum receiver noise or signal level. The PRESELECT control may require re-peaking as the transceiver is tuned across the band.

- (3) The RX CLARIFIER may be utilized if the received signal is drifting. Push the RX button, and rotate the CLARIFIER control for offset of up to 2.5 kHz. A red LED indicator will light up when the clarifier is in use.
- (4) When pulse-type noise is encountered, the NB (Noise Blanker) switch should be activated. Advance the noise blanker level control (located on the front panel) to the point which provides the desired blanking. Do not advance the level control beyond the point required to eliminate the noise pulses.
- (5) For varying the width of the IF passband, press the WIDTH button, and rotate the WIDTH control. In the IF, two 8-pole crystal filters are used. One filter is fixed, and presents a boundary for the bandwidth. The center frequency is then varied across the passband of the second filter, using a mixing scheme that provides no change of pitch in the received signal.

The result is continuously variable bandwidth, from 2.4 kHz down to approximately 300 Hz. When the WIDTH switch is turned OFF, the second IF filter is instantly aligned with the first filter, returning the receiver to a 2.4 kHz bandwidth.

- (6) For extremely strong signals, the ATT (attenuator) switch may be activated, providing 10 dB or 20 dB of attenuation on the incoming signal path, depending on the position of the ATT switch.

TRANSMITTER TUNING

The following tuning procedure must be performed prior to commencing operation on the desired mode. See the paragraphs relating to the specific mode after basic transmitter tune-up has been accomplished.

Be certain that a dummy load or matched antenna is connected to the antenna receptacle on the rear apron of the transceiver. It is possible to damage the final amplifier components of this equipment if this simple precaution is not followed prior to commencing transmission.

LOADING POSITIONS

Do not exceed 10 seconds of key-down time while tuning.

As well, be certain that the ACC plug is inserted into the rear apron ACC jack. Without this plug, there will be no power applied to the tube heaters. Heater voltage is applied through pins 1 and 2 of the accessory socket.

| BAND | FREQUENCY | POSITION |
|-------|-----------|----------|
| 160m | 1.8MHz | 2.5 |
| | 2.0MHz | 6.0 |
| 80m | 3.5MHz | 3.0 |
| | 4.0MHz | 6.0 |
| 40m | 7.0MHz | 6.0 |
| | 7.5MHz | 6.5 |
| 30m | 10.0MHz | 7.0 |
| | 10.5MHz | 8.0 |
| 20m | 14.0MHz | 3.0 |
| | 14.5MHz | 4.0 |
| 17m | 18.0MHz | 2.0 |
| | 18.5MHz | 2.0 |
| 15m | 21.0MHz | 2.0 |
| | 21.5MHz | 2.5 |
| 12m | 24.5MHz | 3.0 |
| | 25.0MHz | 3.0 |
| 10m A | 28.0MHz | 2.0 |
| 10m B | 28.5MHz | 2.0 |
| 10m C | 29.0MHz | 2.0 |
| 10m D | 29.5MHz | 2.0 |

- (1) Preset the controls and switches as follows:
 MODE TUNE
 DRIVE Fully counterclockwise
 DELAY Fully counterclockwise
 MIC GAIN Fully counterclockwise
 COMP LEVEL ... Fully counterclockwise
 HEATER ON
 PROC OFF
 PO/IC/ALC IC
 PLATE Set to desired band segment
 LOADING 0
 PRESELECT Peaked on receive for maximum response
 TX CLARIFIER .. OFF (button not pushed)

NOTE: LOADING positions are nominal. Minor variations from positions shown are to be expected.

- (2) Turn the HEATER switch ON, and wait 1 minute for the tube heaters to warm up.
- (3) Set the VOX GAIN switch to the MOX position. Observe the reading on the IC meter: it should read 50 mA with no drive applied. If it is not, adjust the PB-1968 BIAS control for a resting current of 50 mA on the IC meter. Refer to the BIAS Adjustment on Page 37. Be certain that the DRIVE control is fully counterclockwise for this adjustment.
- (4) Set the VOX GAIN switch to MOX. Advance the DRIVE control for a reading of 150 mA.
- (5) Peak the PRESELECT control for a maximum meter reading. If the meter reading exceeds 150 mA, reduce the setting of the DRIVE control.
- (6) Rotate the PLATE control for a minimum reading ("dip") on the IC meter. Return the transceiver to the receive mode by rotating the VOX GAIN switch out of the MOX position.

FINAL TUNING

Final transmitter tuning uses the relative power output setting of the METER switch. At full rated output, using a 50 ohm load, the PO meter will indicate between 1/2 and 2/3 of full scale deflection. If the PO reading is too high (off scale) or too low (1/4 scale or less), and if the load impedance is very close to 50 ohms, the PO ADJ control on the rear apron may be varied to provide the proper deflection. Once the PO meter is calibrated, off-scale deflections are the result of reflected power (high SWR), and corrective action may be required in the antenna system.

Set the controls as follows for final tuning:

- (1) Set the METER switch to PO. Rotate the DRIVE control to the 9 o'clock position.
- (2) Rotate the VOX GAIN control to the MOX position, and rotate the PRESELECT control for a maximum meter reading.
- (3) Rotate the LOADING control for a maximum meter reading. Rotate the PLATE control for a maximum meter reading.
- (4) Again rotate the LOADING control and PLATE control, each time advancing the

For Service Manuals Contact
 MAURITRON TECHNICAL SERVICES
 8 Cherry Tree Rd, Chinnor
 Oxon OX9 4QY
 Tel:- 01844-351694 Fax:- 01844-352554
 Email:- enquiries@mauritron.co.uk

DRIVE control approximately 2 steps, until the DRIVE control is fully clockwise. The transmitter is now tuned for maximum power output. Do not exceed the maximum tuning time stipulated previously. Return the VOX GAIN switch to the VOX position (out of the MOX position), return the METER switch to IC, and return the DRIVE control to the fully counterclockwise position.

SSB OPERATION

After completing the above tuning procedure, set the MODE switch to USB or LSB as desired. Set the VOX GAIN control to PTT, and activate the transmitter by pushing the microphone PTT switch or the footswitch, if used. With the METER switch set to the ALC position, speak into the microphone in a normal voice. Advance the MIC GAIN control until the meter kicks up to the midscale of the green-colored portion of the meter scale.

Note: When the METER switch is set to IC, voice modulation peaks will indicate 150 - 200 mA. Actual peak current, though, is approximately 2 times the indicated value.

To set the sensitivity of the VOX (voice-operated T/R switching) system, advance the VOX GAIN control slowly while speaking into the microphone. Advance the VOX GAIN control to the point where the speech signal activates the transmitter.

Set the antitrip potentiometer on the rear apron to the minimum point which prevents the speaker output from tripping the VOX. Do not use more VOX gain nor antitrip than is necessary. Adjust the front panel DELAY control for the desired relay recovery time.

RF SPEECH PROCESSOR ADJUSTMENT

The FT-101ZD RF speech processor, when correctly adjusted, will improve the intelligibility threshold at the receiving end, by increasing the average SSB power output. RF clipping is applied to the IF signal, which is then filtered to remove harmonics and out of band intermodulation products. RF envelope clipping causes much less distortion than that caused by an equivalent amount of AF clipping, and the result is an output signal with more "punch".

Set the PROC switch to OFF, and set the MIC GAIN control as described previously (voice peaks falling within the green zone of the ALC meter scale). Now set the PROC switch to ON, and set the COMP LEVEL control to the 10 o'clock position. Advance the DRIVE control so that the desired power output is obtained, and be sure that the ALC meter indication is within the green zone.

With the RF speech processor activated, the ALC meter indication may not be quite as high as when the processor is off. This is entirely normal, because the average power output is higher with the processor, although the peaks are being clipped.

Setting the COMP LEVEL control up to the 3 o'clock position will provide up to 10 dB of compression. Advancing the control beyond the 10 o'clock point may, however, degrade the voice-to-noise ratio, so caution is recommended.

CW OPERATION

After completing the tuning procedure, insert the key line into the KEY jack on the rear panel.

The operator may select any power output desired by advancing the DRIVE control. Once the maximum power output level has been reached, the DRIVE control should not be advanced further.

The transmitter may be activated by the VOX circuit, or by the PTT or MOX systems. The TONE control on the rear apron of the transceiver sets the CW sidetone level.

The key-up voltage at the key jack is 7 volts, and the key-down current is 1.5 mA.

For receiving, two positions of selectivity are provided. When the optional CW filter is installed, the operator may select between the 600 Hz bandwidth of the CW filter and the 2.4 kHz bandwidth of the SSB filter. The WIDTH control may be used with either position of the MODE switch: CW-W or CW-N.

AM OPERATION

AM operation of the transmitter is accomplished by setting the MODE switch to the AM position and inserting the proper amount of carrier with the DRIVE control.

After completing basic transmitter tune-up, place the MODE switch in the AM position. Activate the transmitter, and rotate the DRIVE control until the meter reads .10 (100 mA) in the IC position of the METER switch. While speaking into the microphone in a normal voice, increase the MIC GAIN control until the meter indicates very slight movement with voice peaks. Care must be exercised that the DRIVE control is not advanced too far. Do not exceed .10 (100 mA) meter indication during AM operation or damage to the transmitter final amplifier tubes may result.

For Service Manuals Contact
MAURITRON TECHNICAL SERVICES
8 Cherry Tree Rd, Chinnor
Oxon OX9 4QY
Tel: 01844-351694 Fax: 01844-352554
Email: enquiries@mauritron.co.uk

SELECT SWITCHES

The SELECT switches allow selection of internal or external VFO frequency control, as well as selection of up to 2 optional crystal-controlled channels.

When the crystal-controlled channels are installed, they may be selected by pressing CH1 or CH2, as desired. See the crystal information elsewhere for full information on crystal requirements.

The external VFO, FV-101Z and FV-901DM, which provide versatile operations with your FT-101ZD, are available from your Yaesu dealer.

Because there is no calibrated dial for the FV-901DM, it can't be used with the analog FT-101Z.

For transceive frequency control on the external VFO, press EXT. For external VFO control of the transmit frequency, with receive frequency control on the FT-101ZD, press TX EXT. For receive frequency control on the external VFO, and transmit frequency control on the FT-101ZD, press RX EXT. For full transceive control on the FT-101ZD, press VFO.

DIAL CALIBRATION AND FREQUENCY DETERMINATION

The FT-101ZD mixing scheme accounts for the difference in carrier frequencies between USB and LSB. For this reason, no recalibration is required. Once the calibration is properly aligned (at the factory, or in shop), no further adjustment is required for accurate frequency derivation. The 25 kHz calibrator is included largely for alignment purposes, as it provides a useful reference signal for signal peaking, etc.

Frequency readout on the FT-101ZD digital display is straightforward. The full operating frequency is displayed, with resolution to 100 Hz.

The analog display on the FT-101Z and FT-101ZD transceivers provides easy determination of the operating frequency. The frequency displayed on the analog sub dial (and the main display window, for the FT-101Z) is added to the lower band edge frequency.

For example, if the analog dial indicates 074, as shown in the example, and the BAND switch is on 40 meters (lower band edge: 7000 kHz), the operating frequency will be 7074 kHz. By rotating the BAND switch, this position of the analog display will produce 14074 kHz for 20 meters, 21074 for 15 meters, etc. For 80 and 12 meters, the lower band edges are 3500 kHz and 24500 kHz, while for 160 meters the band edge is 1.5 MHz. Therefore, the dial should read 074 to produce 3574 kHz, but 374 for 1874 kHz. Be careful so as not to operate outside the amateur bands.

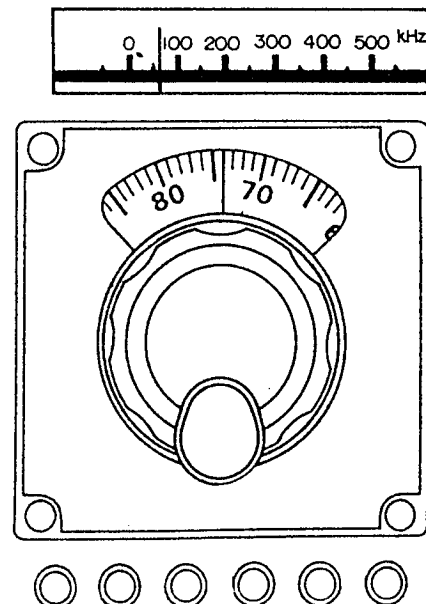

FIXED CHANNEL CRYSTAL INFORMATION

Two fixed channels may be used with your FT-101ZD, using optional crystals. Crystals are available from your Yaesu dealer. Crystals must meet the specifications shown in Table 2, and must fall within the operating range 5500 - 5000 kHz. Frequency calculation is made from the formula

$$F_x = F_1 - F_0$$

where F_x is the crystal frequency.

F_1 is a constant derived from Table 1

F_0 is the operating frequency.

For example, let us say it is desired to operate on 7199 kHz LSB. Referring to Table 1, we see that for 40 meter LSB, F_1 is 12501.5 kHz. Subtracting F_0 (7199 kHz) from F_1 (12501.5 kHz) yields 5302.5 kHz, the crystal frequency (F_x).

For operation on 21420 kHz USB, compute the crystal frequency as follows:

$$F_x = 26498.5 - 21420 = 5078.5 \text{ kHz.}$$

Inspection of the values of F_1 in Table 1 will reveal that the 7199 kHz crystal for LSB will work on 14199 kHz, 21199 kHz, etc. Of course, LSB is not normally used on these bands. If the operator switches to USB, the operating frequency will be moved 3 kHz (in this case, to 14196 kHz, 21196 kHz, etc.). If the move is made from LSB to CW, the frequency will move 2.3 kHz down.

| MODE BAND | U S B | L S B | C W |
|--------------|---------|---------|---------|
| 160m | 6998.5 | 7001.5 | 6999.2 |
| 80m | 8998.5 | 9001.5 | 8999.2 |
| 40m | 12498.5 | 12501.5 | 12499.2 |
| 30m | 15498.5 | 15501.5 | 15499.2 |
| 20m | 19498.5 | 19501.5 | 19499.2 |
| 17m | 23498.5 | 23501.5 | 23499.2 |
| 15m | 26498.5 | 26501.5 | 26499.2 |
| 12m | 29998.5 | 30001.5 | 29999.2 |
| 10m A | 33498.5 | 33501.5 | 33499.2 |
| 10m B | 33998.5 | 34001.5 | 33999.2 |
| 10m C | 34498.5 | 34501.5 | 34499.2 |
| 10m D | 34998.5 | 35001.5 | 34999.2 |

Table 1

| Type | HC-25/U |
|--------------------|-----------------|
| Load Capacitance | 30pF |
| Series Resistance | 25 Ohms or less |
| Static Capacitance | 7pF or less |
| Drive Level | 5mW |

Table 2

For Service Manuals Contact
MAURITRON TECHNICAL SERVICES
 8 Cherry Tree Rd, Chinnor
 Oxon OX9 4QY
 Tel:- 01844-351694 Fax:- 01844-352554
 Email:- enquiries@mauritron.co.uk

CW FILTER INSTALLATION (OPTION)

- (1) Remove the top cover of the transceiver case, as shown in Fig. 1.
- (2) Refer to Fig. 2, and locate the NB-FIX circuit board. Remove its mounting screws, because this board is obstructing the removal of the IF unit.
- (3) Remove the 12-pin, 13-pin, and 15-pin plugs from their sockets on the IF unit. Remove the IF unit mounting screws, and remove the IF unit from the transceiver case.

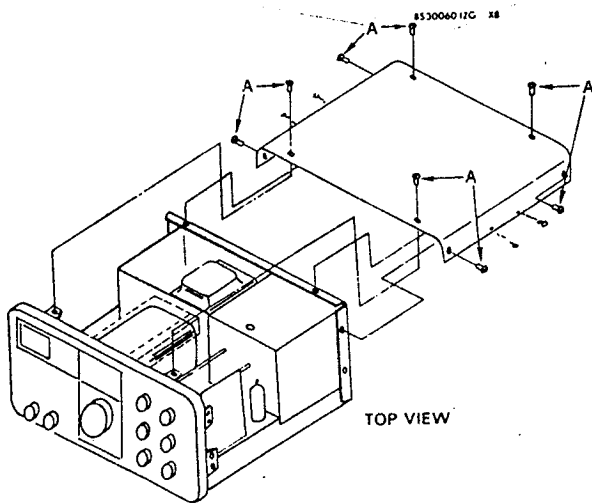

Figure 1

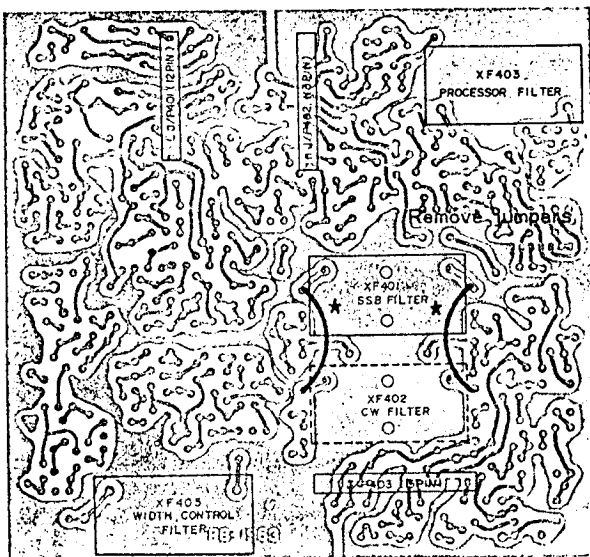

Figure 3

- (4) Install the optional CW filter as shown in the foil side view of the IF unit (Fig. 3). Make the fastening nuts snug, and solder the pins of the filter to the circuit board, and remove the 2 jumper wires shown in Figure 3.
- (5) Re-install the IF unit, being careful to connect the 12-pin, 13-pin, and 15-pin plugs in the correct sockets. Refer to Fig. 2 to be sure. Re-install the NB-FIX unit, and replace the top cover of the transceiver.
- (6) When the optional CW filter is installed, the CW-N position of the mode switch will activate this filter. In the CW-W position, the SSB 2.4 kHz filter will be in use. The WIDTH control is usable in all modes.

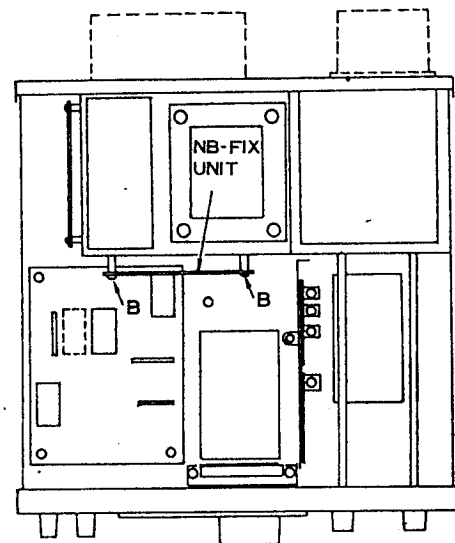

Figure 2

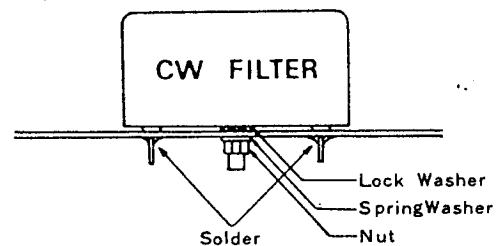

Figure 4

DC-DC CONVERTER INSTALLATION (OPTION)

The optional DC-DC converter is easy to install in a matter of minutes. Please follow the instructions carefully, in order to make the proper connections.

- (1) Install the DC-DC converter module as shown in the drawing. Use the four screws supplied with the kit. Do not force the plug into the socket, as the connection should be smooth, yet solid.
- (2) Check the DC cable fuse socket, located in the positive (red) lead, to be certain that a 20 amp fuse is installed.
- (3) When making connections to the battery, be absolutely certain that the proper polarity is observed. The RED lead should be connected to the POSITIVE (+) battery terminal, and the BLACK lead should be connected to the NEGATIVE (-) terminal. **OUR WARRANTY DOES NOT COVER DAMAGE CAUSED BY REVERSED POLARITY CONNECTIONS.**
- (4) Before connecting the DC power cable to the transceiver, check the automobile voltage regulator level with the engine running (battery charging). The maximum charging rate

should be 15 volts or less. If the voltage is higher than this level, please adjust the voltage regulator for a maximum of 15 volts. This precaution applies, as well, to bench power supplies, which should be adjusted in the same fashion. Also, the transceiver should not be operated from a supply voltage of less than 12 volts.

- (5) Connect the DC cable to the transceiver. Power connections are made automatically when the DC cable is connected to the POWER jack.

NOTES ON MOBILE INSTALLATION

Be certain that sufficient room is provided for free air circulation around the transceiver. If the transceiver must be placed on the car seat, set it on a board or other rigid object, in order to provide the necessary air circulation (and to avoid possible heat damage to the upholstery).

A special mobile mounting bracket is available from your YAESU dealer.

The DC supply should be capable of providing 20 amps on voice peaks, 14 amps continuous. The HEATER switch may be turned off during long periods of reception, for energy conservation.

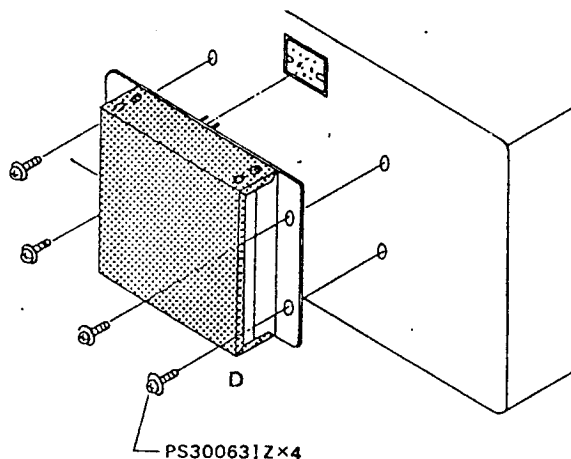

For Service Manuals Contact
MAURITRON TECHNICAL SERVICES
8 Cherry Tree Rd, Chinnor
Oxon OX9 4QY
Tel:- 01844-351694 Fax:- 01844-352554
Email:- enquiries@mauritron.co.uk

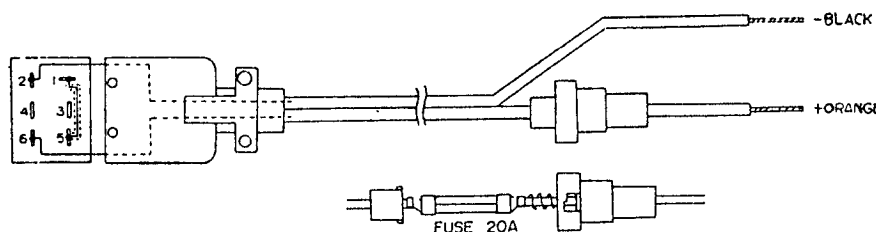

COOLING FAN INSTALLATION (OPTION)

The FT-101ZD cooling fan may be used with other models of Yaesu equipment. Installation is easily accomplished in minutes.

Hold the fan up to the rear panel in its proper location. Determine the proper length of the two-wire power lead to the motor. Solder the leads to the 2-pin plug supplied with the fan. The 4-pin plug is not needed for FT-101ZD installation.

Install the fan onto the rear panel of the transceiver, as shown in the drawing. Insert the power lead from the fan into the fan socket on the rear panel.

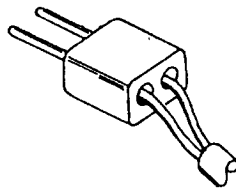
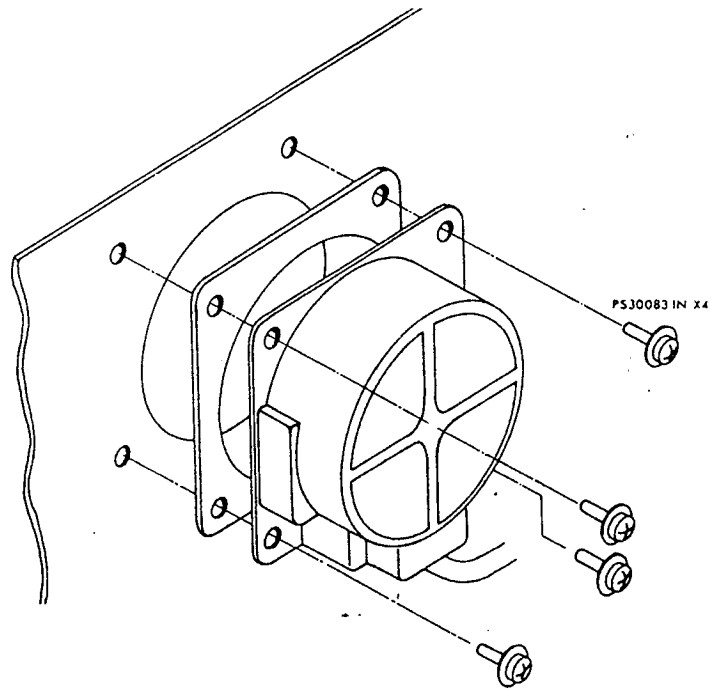

Fan. plug

COUNTER UNIT INSTALLATION ON FT-101Z

This section will deal with the installation of the COUNTER UNIT and digital display, which are optional equipment for the economy FT-101Z model.

PARTS NEEDED

| | |
|--------------------------------------|-----|
| Optical Filter with double-face tape | (1) |
| Counter Module | (1) |
| Guide Pins | (2) |
| Support Tower | (1) |
| Vinyl Tubes | (2) |

- (1) Remove the top cover of the transceiver, according to the drawing on page 17.
- (2) Remove the screws marked "A" in Figure 1. These screws support the LED board.
- (3) Remove the screws marked "B" in Figure 1, as well as the tension spring, and remove the analog display panel.
- (4) Locate the analog display lamp. Cut the leads to this lamp, insert 1 lead each into the vinyl tube supplied with the counter kit, and position these leads out of the way of the VFO gears, etc.
- (5) Install the orange optical filter on the inside of the front panel of the transceiver, in the position formerly occupied by the analog display panel. Be sure that it is correctly centered. The filter is held in place by the double-face tape included with the filter.
- (6) Install the two guide pins into the holes previously occupied by the "A" screws. When doing this, install the LED board in its previous position. Install the support tower into the hole marked "C" in Figure 1.
- (7) Remove the 820 ohm (Gray-Red-Brown) resistor from the terminal strip marked "E" in Figures 1 and 2.
- (8) Install the COUNTER UNIT. The connection to the guide pins should not be forced. Use the screws previously installed at "A" for securing the counter module at points "C" (support) and "D" in Figure 1. Connect the COUNTER UNIT 9-pin plug into the 9-pin

socket on the transceiver at point "G" in the drawing. The coaxial cable from the COUNTER UNIT is connected to point "F" in Figure 1.

- (9) Close the transceiver. No alignment of the unit is necessary, unless some change in the preset carrier frequencies is required for a special application. In this case, refer to the section on the COUNTER UNIT in the "ALIGNMENT" chapter of this manual.

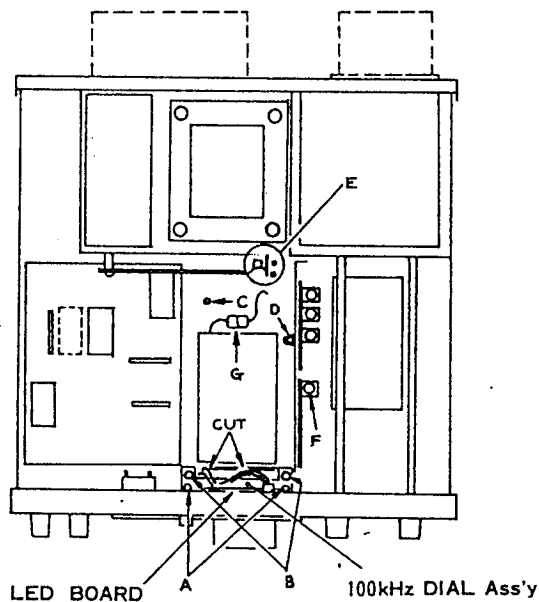
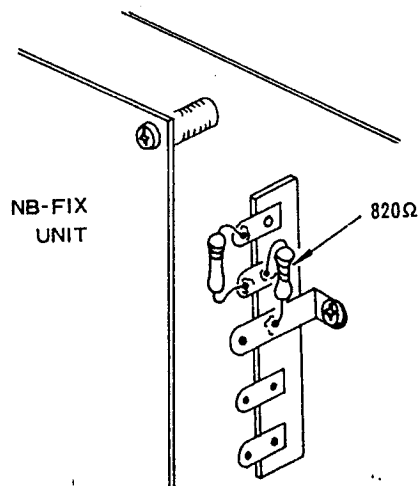

Figure 1



(Enlarged) Part E

Figure 2

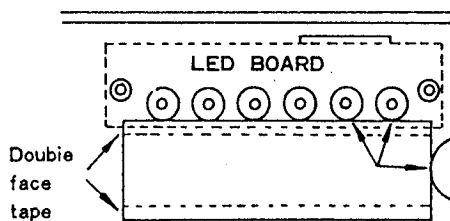

Figure 3

CIRCUIT DESCRIPTION

The block diagram and following circuit description will provide you with a better understanding of the design of this transceiver. The circuit description is tailored to the full-feature FT-101ZD, and the reader should note that the counter unit and digital display are optional features for the FT-101Z.

The FT-101ZD consists of a pre-mix-type single conversion system, using a 9 MHz IF for all modes of operation.

RECEIVER

The RF input signal from the antenna is fed through antenna relay RL₂, lamp fuse FH₂, attenuator switch S₂₀₀₄ (located on the LEVER SW unit, PB-1975), 9 MHz trap L₂₁₀₁ and C₁₂₀₇ (located on the TRIMMER A UNIT), and input transformer T₁ to pin 3 of the RF UNIT.

RF UNIT (PB-2154)

The incoming signal is amplified by the RF amplifier, Q₁₀₁ (3SK51-03), a dual-gate MOS FET with excellent rejection of cross modulation and intermodulation. The amplified signal is fed to the Schottky barrier diode module, Q₁₀₂ (ND487C2-3R), where the RF signal is mixed with a local signal delivered from Q₁₀₄ (2SC2407), resulting in a first IF of 8.9875 MHz. The IF signal is then amplified by Q₁₀₃ (J310) and fed to J₁₀₁.

IF UNIT (PB-1963)

The IF signal at pin 9 of J₄₀₃ is amplified by Q₄₀₈ (J310) and passed through a monolithic filter, XF₄₀₄, which has a ±10 kHz bandwidth. The monolithic filter provides early protection from IMD, while providing a wide-bandwidth point for noise blanking. The IF signal is then fed to noise blanker gate D₄₀₄ (1S1007), which functions as an ON/OFF switch controlled by noise blanker driver Q₄₁₁ (MPSA13).

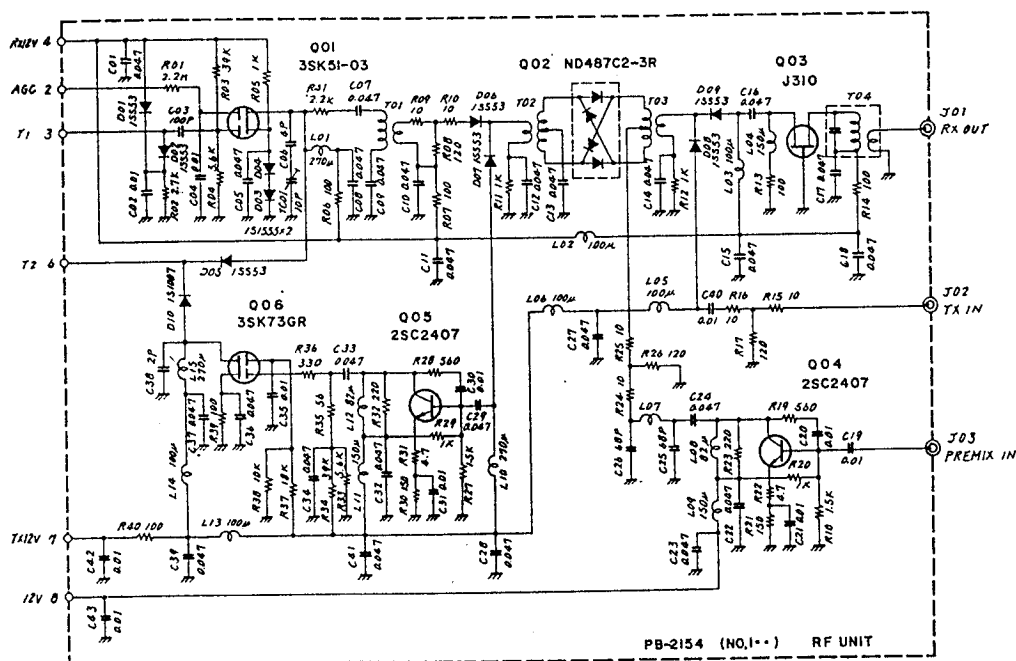

The IF signal is then passed through the SSB filter XF₄₀₁ (or optional CW filter XF₄₀₂). Selection of the filter to be used is made by diodes D₄₀₅ - D₄₀₈ (1S1007), depending on the mode of operation.

The IF signal is then fed to the first mixer, Q₄₁₂ (3SK51-03), where the incoming signal is heterodyned with a 19.7475 MHz \pm Δ f local signal delivered from crystal oscillator Q₄₂₁ (2SC535A) and buffer amplifier Q₄₂₃ (2SC372Y), resulting in a signal of 10.76 MHz \pm Δ f.

The new 10.76 MHz \pm Δ f signal is fed through filter XF₄₀₅ to the IF second mixer, Q₄₁₃/Q₄₁₄ (2SK19GR), where the filtered signal is heterodyned with the 19.7475 MHz \pm Δ f signal delivered from Q₄₂₂ (2SC372Y), resulting in an 8.9875 MHz IF signal, the same as the original IF.

This process varies the IF signal across the passband of the second IF filter. The combination of the two filters, XF₄₀₁ and XF₄₀₅, provides continuously variable width of the IF passband. The frequency of crystal oscillator Q₄₂₁ is varied by varactor diode D₄₁₈ (1S2209).

The output from the IF second mixer is fed to a two-stage IF amplifier, consisting of Q₄₁₅ and Q₄₁₆ (3SK51-03), and delivered through diode switch D₄₀₁ (1S1555) to the AF UNIT.

A portion of the output from Q₄₁₆ is rectified by D₄₁₆ and D₄₁₇ (1N60) to produce AGC voltage. Q₄₁₇ (2SC372Y) provides the necessary buffering between the IF and AGC circuits. The AGC voltage is amplified by Q₄₁₈ (2SC372Y), and applied to gate 2 of the RF and IF amplifiers, to control the gain of these stages. The AGC voltage is also amplified by Q₄₁₉ (2SK19GR) for S-meter indication.

For use with the FV-101Z or FV-901DM scanning VFO, or other optional equipment, the AGC voltage is fed through buffer Q₄₂₅ (2SK19GR) and fed to the AGC OUT terminal on the EXT VFO jack, located on the rear panel.

On AM, the output signal from Q₄₁₆ is amplified by Q₂₄₀₈ (2SC380Y) and passed to the AM detector, D₂₄₀₆ (1N60). The resulting audio signal is amplified by Q₂₄₀₉ (2SC1815Y) and delivered to the final audio stage.

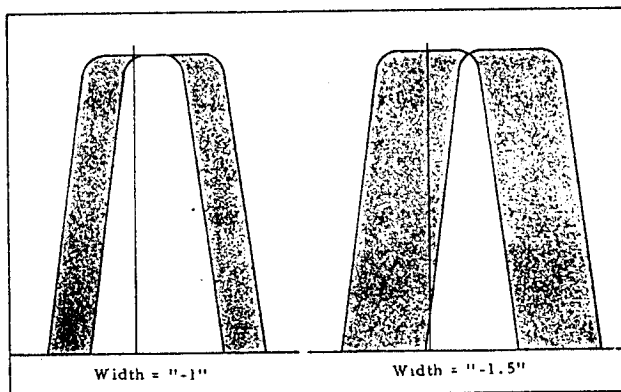
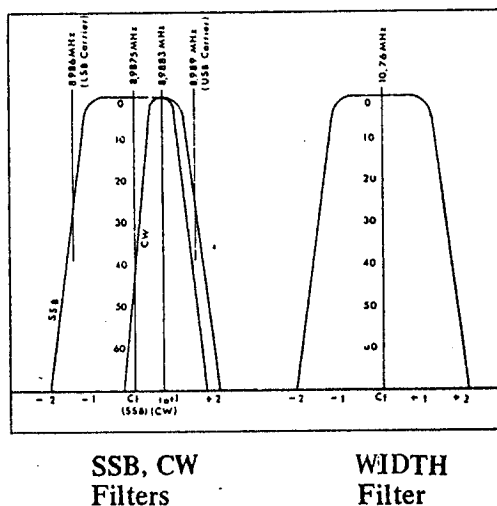

Width Control Action

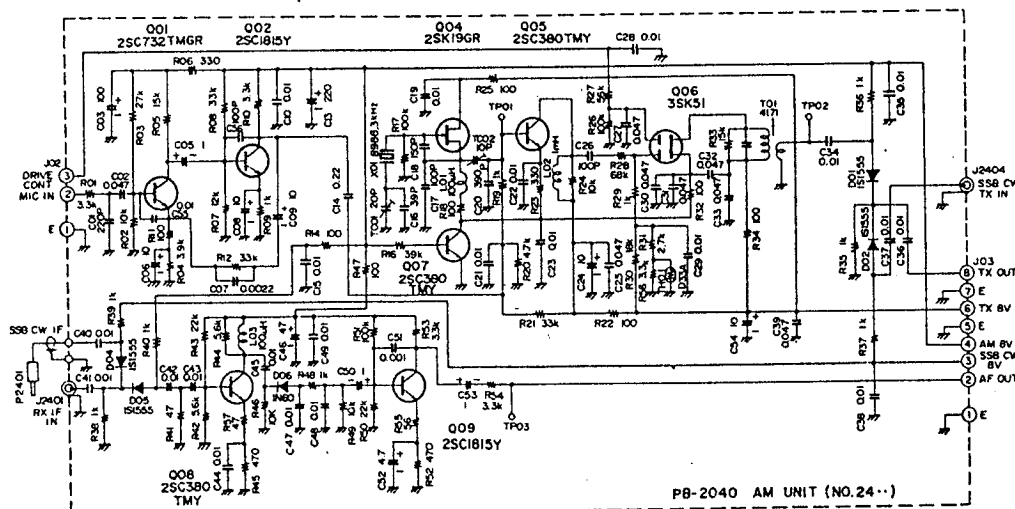

NB-FIX UNIT (PB-1961)

A portion of the 8.9 MHz IF signal is fed through buffer Q₄₁₀ (2SC372Y) and amplified by Q₂₀₆ and Q₂₀₅ (2SC1583).

When a carrier of noise-free modulated signal is received, the IF signal is rectified by D₂₀₁ and D₂₀₂ (1N60), producing a DC voltage. This DC voltage is amplified by Q₂₀₂ (2SC372Y), which charges C₂₁₄, for AGC purposes. The AGC voltage is used to control the gain of Q₂₀₆ and Q₂₀₅.

When impulse-type noise is received, D₂₀₃ and D₂₀₄ (1N60) rectify the IF signal, producing a DC voltage which controls the NB switch Q₄₁₁ (2SC372Y).

Noise pulses have a very short duration, but high amplitude. Because of the very slow time constant of the C₂₁₄/R₂₁₂ discharge path, AGC voltage is not induced by these short-duration pulses. Therefore, Q₂₀₆ and Q₂₀₅ operate at full gain, providing maximum voltage to the base of Q₄₁₁. When a pulse is received, Q₄₁₁ biases D₄₁₄ to block the signal path momentarily. When a desired signal and a noise pulse are received simultaneously, the blanking action is not impaired, because the relative amplitude difference between the desired signal and the noise pulse is still high. The front panel noise blanker level control varies the DC voltage applied to the base of Q₄₁₁.

AF UNIT (PB-1964)

The IF signal from pin 2 is fed through T₅₀₁ to the ring demodulator, consisting of D₅₀₂ - D₅₀₅ (1S1007), where the IF signal is demodulated into audio, using the carrier signal delivered from Q₅₀₃ (2SC1815Y). The carrier signal is generated by oscillator Q₅₁₄ (2SK19GR), and it oscillates at one of the following frequencies:

| | |
|------------|------------|
| USB, CW-RX | 8989 KHz |
| LSB | 8986 KHz |
| CW-TX | 8988.3 KHz |

The audio signal is then amplified by audio amplifiers Q₅₀₇, Q₅₀₈ (2SC1000GR), and Q₅₀₉ (μPC2002), delivering 3 watts of audio output to the speaker.

The audio spectrum is shaped by an active low-pass filter of $f_0 = 2.7$ kHz, -12 dB/octave.

MARKER GENERATOR

A 25 kHz marker signal is provided, for alignment and testing purposes. Marker generator Q₅₀₉ (2SC1815Y) generates a basic 3200 kHz signal, which is divided into 25 kHz multiples by Q₅₀₆ (MC14024B), a binary counter.

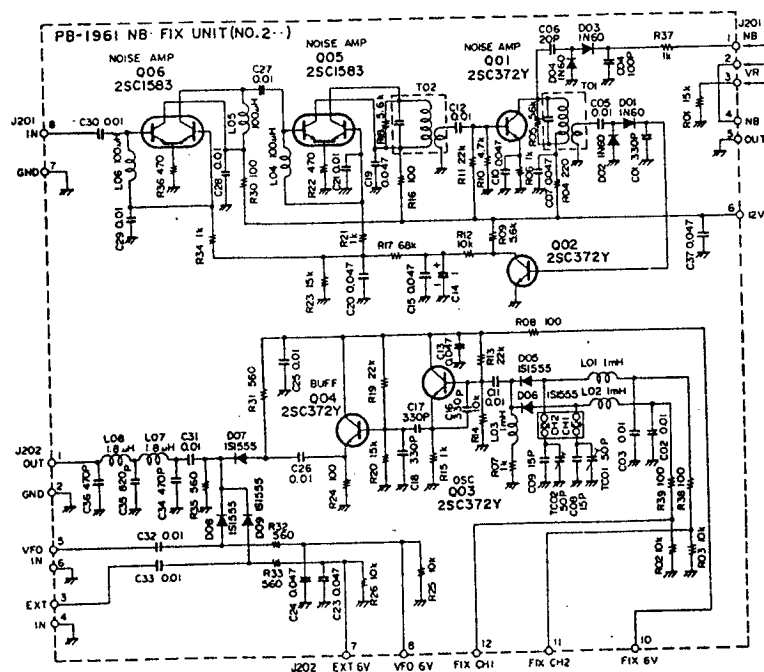

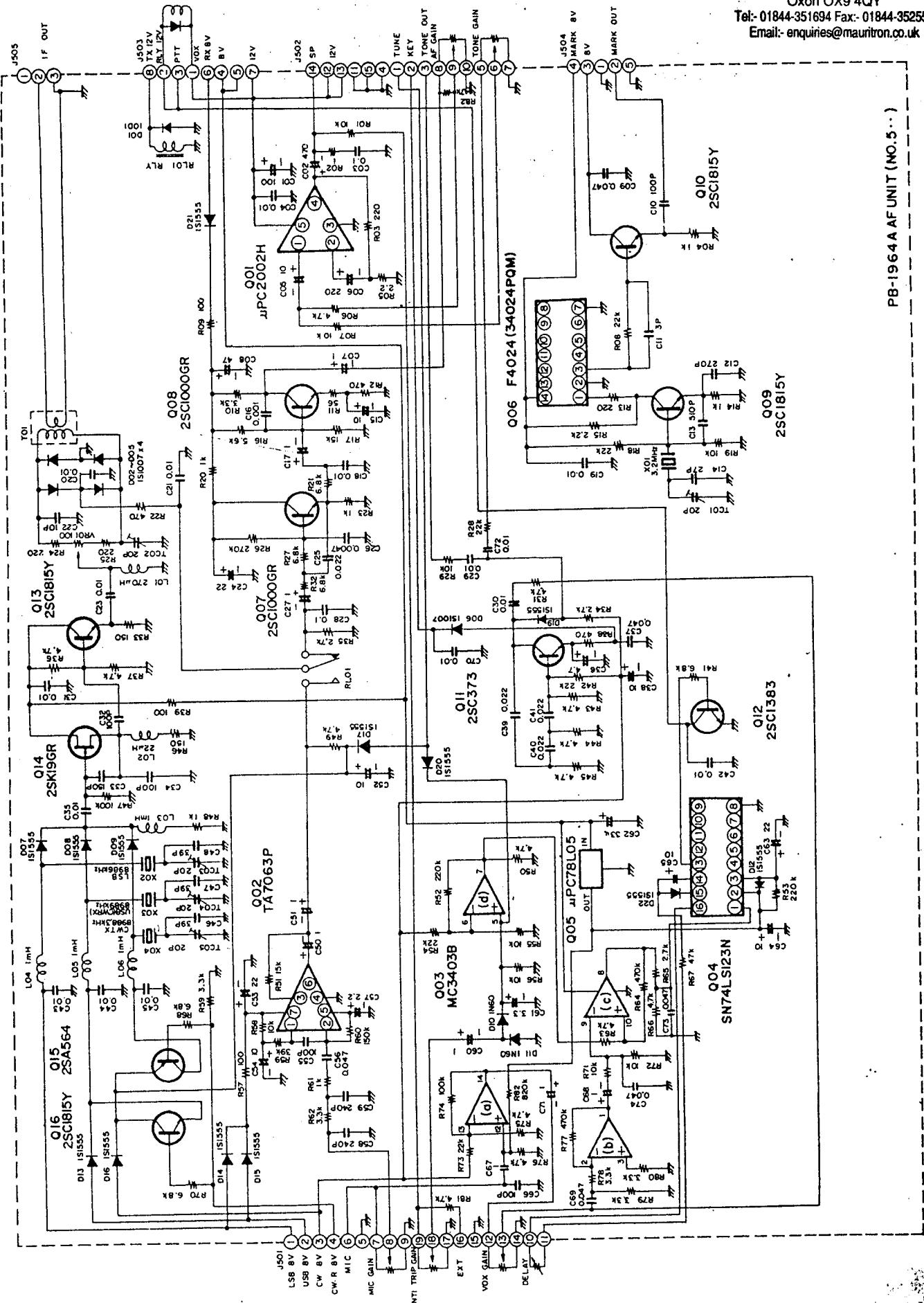

PB-1964A AF UNIT (NO.5...)

TRANSMIT CIRCUIT

SSB MODE

The output from microphone jack J₂ is fed through the MIC GAIN control VR_{3a} to pin 8 of the AF UNIT.

AF UNIT (PB-1964A)

The speech signal from pin 8 is amplified by microphone amplifier Q₅₀₂ (TA7063P) and fed through relay RL₅₀₁ to the ring modulator, D₅₀₂ - D₅₀₅, where the speech signal modulates the carrier signal delivered from Q₅₁₃. The resulting double sideband signal is fed to the IF UNIT.

IF UNIT (PB-1963)

The 8.9875 MHz double sideband signal is amplified by Q₄₀₁ (3SK51-03) and passed through sideband filter XF₄₀₁ by diode switches D₄₀₃, D₄₀₉ (1S1555), D₄₀₅, and D₄₀₇ (1S1007). Here the signal is converted to a single sideband signal by removal of the unwanted sideband.

The signal is then fed to buffer amplifier Q₄₀₂ (2SK19GR). When the RF speech processor is OFF, diode switches D₄₁₁ and D₄₁₂ (1S1555) feed the IF signal to IF amplifier Q₄₀₅ (3SK51-03). When the RF speech processor is ON, the SSB signal is amplified by buffer amplifier Q₄₀₂ (2SK19GR) and further amplified by limiter Q₄₀₃ (TA7060P), where signals that exceed the preset clipping level are sliced out.

This highly clipped SSB signal is amplified by buffer amplifier Q₄₀₄ (2SC372Y) and passed through a selective filter, XF₄₀₃, which removes RF harmonics that result from signal clipping. The signal is then fed to IF amplifier Q₄₀₅, and subsequently delivered to the RF UNIT. The front panel COMP LEVEL control, VR₄, controls the voltage at gate 2 of Q₄₀₁, thus setting the processor level.

The return of the grid circuit of the final amplifier tubes is fed to Q₄₀₆ (2SK19BL), which produces ALC voltage. This voltage is fed to gate 1 of Q₄₀₅,

controlling the gain of this stage. When the RF processor is off, ALC voltage is also fed to gate 1 of Q₄₀₁. Q₄₀₇ (2SA564) amplifies the ALC voltage for indication on the front panel meter.

RF UNIT (PB-2154)

The IF signal from J₁₀₂ is delivered to the Schottky barrier diode module Q₁₀₂ (ND487C2-3R), where the IF signal is mixed with a local signal delivered from Q₁₀₄ (2SC2407), producing the RF output signal. The RF signal is then amplified by Q₁₀₅ (2SC2407) and Q₁₀₆ (3SK40M), and fed through diode switch D₁₁₀ (1S1007) to the DRIVE UNIT.

DRIVE UNIT (PB-1714), PA UNIT (PB-1715)

The RF signal is amplified by driver V₁₆₀₁ (12BY7A), and delivered to PA UNIT final amplifier tubes V₁₇₀₁ and V₁₇₀₂ (6146B). The output from the final tubes is fed to the antenna jack.

A portion of the RF signal is coupled through C₁₄ to the cathode of the 12BY7A driver, for the purpose of improving the linearity of the final amplifier. This technique is known as RF negative feedback.

CW MODE

For CW, the 8.9883 MHz carrier is generated by oscillator Q₅₁₄ at the frequency set by X₅₀₄. The carrier signal is fed through buffer Q₅₁₃ and fed to the ring modulator. The same carrier frequency is used in the tune mode.

DC voltage is applied through diode switch D₅₁₇ (1S1555) and relay RL₅₀₁, unbalancing the ring modulator for CW operation. The carrier signal is then fed to the IF UNIT. The signal path is identical to that on SSB, up to the DRIVE UNIT.

DRIVE UNIT (PB-1714), PA UNIT (PB-1715)

Keying of the transmitter is accomplished by changing the bias voltage to the driver and final tubes. During "key up," the tubes are cut off by application of -35 volts to V₁₆₀₁ and -110 volts to V₁₇₀₁ and V₁₇₀₂. These cutoff voltages are

reduced to -0.1 volt and -60 volts, respectively, during "key down" conditions.

The key is connected to the KEY 2 terminal on the RECT B board, PB-1968. When the key is closed, the base of Q_{1001} (2SA733) is grounded, causing Q_{1002} (2SC372Y) to conduct. The base of Q_{1003} (2SA639) is thus set to 0 when the transistor conducts. Under these circumstances, the bias voltage applied to V_{1601} , V_{1701} , and V_{1702} places these tubes in the normal operating condition.

VOX circuit

A portion of the microphone input signal is amplified by three stages of Q_{503} (MC3403P), which drive the VOX control gate, Q_{504} (SN74LS123N). The output, from pin 13 of Q_{504} is fed to the base of Q_{512} (2SC1383), switching the VOX relay on and off according to the presence or absence of a speech signal.

A portion of the speaker output is detected by D_{510} and D_{511} (1N60), providing a bucking voltage which is fed to Q_{503} , preventing the speaker output from tripping the VOX.

The VOX delay may be set by adjusting VR_{2b} for the desired delay time.

For Service Manuals Contact
MAURITRON TECHNICAL SERVICES
 8 Cherry Tree Rd, Chinnor
 Oxon OX9 4QY
 Tel: 01844-351694 Fax: 01844-352554
 Email: enquiries@mauritron.co.uk

CW SIDETONE

CW sidetone oscillator Q_{511} (2SC373) oscillates at a frequency of approximately 800 Hz. The output from Q_{511} is amplified by the final audio

amplifier, Q_{501} , for delivery to the speaker. The output from the sidetone oscillator is also fed to VOX amplifier Q_{503} , providing semi-break-in operation for CW.

AM MODE

The speech signal from the microphone is amplified by Q_{2401} (2SC732GR) and Q_{2402} (2SC1815Y) and passed to modulator Q_{2405} (2SC380Y), where the speech signal modulates the AM carrier signal at 8988.3 kHz delivered from Q_{2404} (2SK19GR). The modulated signal is amplified by Q_{2406} (3SK51) and delivered to transmit mixer Q_{105}/Q_{106} .

COMMON CIRCUITS

VFO UNIT (PB-1440B-3420)

A modified Colpitts-type oscillator is used to generate a 5.0 - 5.5 MHz VFO signal, thus producing a 500 kHz tuning range. The oscillator signal generated by Q_{801} (2SC372Y) is varied by VC_{801} , which is geared to a precision-built dial tuning mechanism. VC_{801} consists of two sections; the sub-blades compensate for the capacitance variation of the main blades, which may result from extreme temperature change.

Varactor diode D_{801} (1S2209) may be varied by tuning L_{806} , providing ± 2.5 kHz offset from the dial frequency (clarifier).

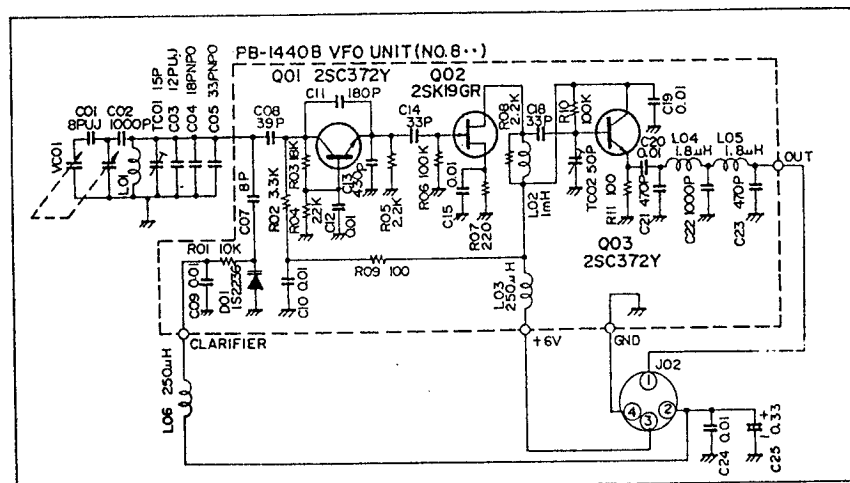

The VFO signal is amplified by buffer amplifiers Q₈₀₂ (2SK19GR) and Q₈₀₃ (2SC372Y), and passed to the PREMIX UNIT.

TX & FIX UNIT (PB-1961)

Two crystal-controlled channels are provided for operation with this transceiver. The oscillator signal is generated by Q₂₀₃ (2SC372Y) and amplified by Q₂₀₄ (2SC372Y), and delivered to the PREMIX UNIT. Crystals X₂₀₁ and X₂₀₂ oscillate in the 5.0 - 5.5 MHz range.

PREMIX LOCAL UNIT (PB-2153)

Crystal oscillators Q₆₀₁-Q₆₁₂ (2SC380Y) generate the premix local signal at the frequencies shown in Table 3. Diode switches D₆₀₁-D₆₁₂ (1S1555) select the proper local signal for the band in use. The local signal is then delivered to the PREMIX UNIT.

PREMIX UNIT (PB-2152)

The premix signal is produced at Q₃₀₃ (SN76514N), a double-balanced mixer, where the premix local signal from Q₆₀₁-Q₆₁₂ is mixed with the VFO or crystal controlled 5 MHz signal. The premix output frequencies are shown in Table 3. The premix signal is passed through bandpass filter T₃₀₁-T₃₀₄, and amplified by Q₃₀₁, Q₃₀₂ (2SC1923R). The amplified signal is then fed to the RF UNIT, where the signal is further amplified by Q₁₀₇ for delivery to the transmitter and receiver mixers.

14-16
14-35
14-50
14-66

| | | XCO Frequency | PREMIX OUT Frequency |
|-------|------------------|---------------|----------------------|
| 160m | X ₆₀₁ | 15.9875MHz | 10.4875~10.9875MHz |
| 80m | X ₆₀₂ | 17.9875MHz | 12.4875~12.9875MHz |
| 40m | X ₆₀₃ | 21.4875MHz | 15.9875~16.4875MHz |
| 30m | X ₆₀₄ | 24.4875MHz | 18.9875~19.4875MHz |
| 20m | X ₆₀₅ | 28.4875MHz | 22.9875~23.4875MHz |
| 17m | X ₆₀₆ | 32.4875MHz | 26.9875~27.4875MHz |
| 15m | X ₆₀₇ | 35.4875MHz | 29.9875~30.4875MHz |
| 12m | X ₆₀₈ | 38.9875MHz | 33.4875~33.9875MHz |
| 10m A | X ₆₀₉ | 42.4875MHz | 36.9875~37.4875MHz |
| 10m B | X ₆₁₀ | 42.9875MHz | 37.4875~37.9875MHz |
| 10m C | X ₆₁₁ | 43.4875MHz | 37.9875~38.4875MHz |
| 10m D | X ₆₁₂ | 43.9875MHz | 38.4875~38.9875MHz |

Table 3

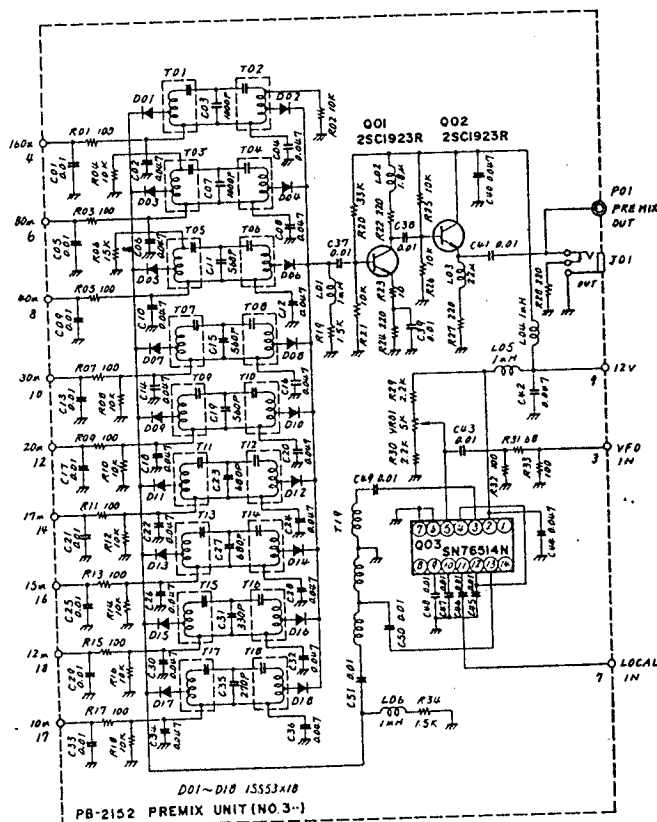
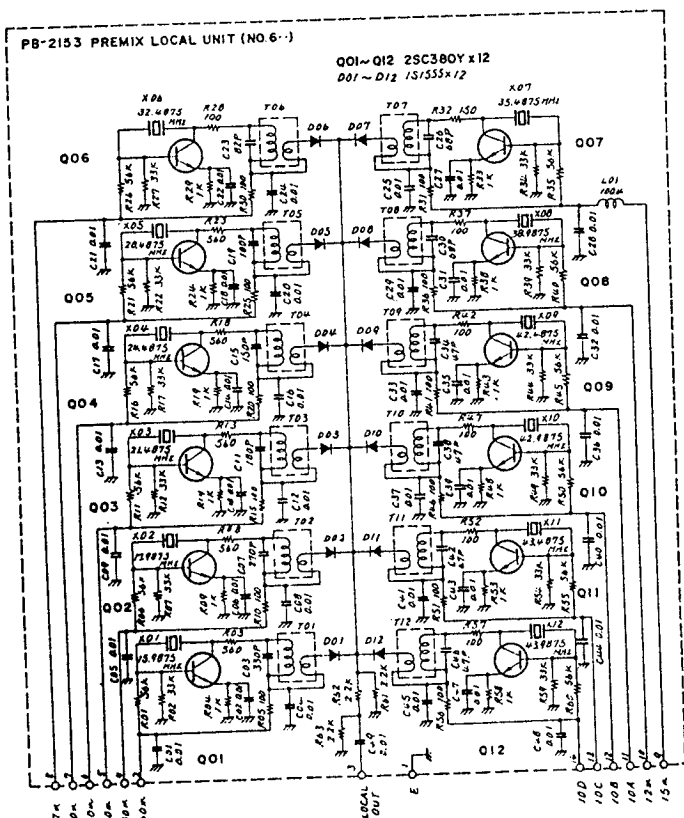

COUNTER UNIT (PB-2086A-3420/PB-2098)

The local oscillator signal is applied to Large-Scale Integrated Circuit (LSI) chip for display on the front panel digital display.

The premix signal as shown in Table 4 from the LOCAL Unit, is amplified by Q₂₃₀₁. The amplified signal is further amplified by Q₂₃₀₃ (2SC1674) and delivered to the LSI counter chip, Q₂₃₁₂ (MSM9520RS). A portion of the output from Q₂₃₀₃ is amplified by Q₂₃₀₄ (2SC1815Y) and fed to gate 2 of Q₂₃₀₁ controlling the gain of those amplifiers.

The output from the LSI is fed to the display. The output from pins 24 through 30 is delivered to segment drivers Q₂₃₁₃–Q₂₃₁₉ (2SA952L) and digit drivers Q₂₃₀₆–Q₂₃₁₁ (2SA952L) through a dynamic drive configuration. Display is performed by D₂₂₀₁–D₂₂₀₆ (HP5082-7623), seven-segment light-emitting diodes.

For Service Manuals Contact
MAURITRON TECHNICAL SERVICES
 8 Cherry Tree Rd, Chinnor
 Oxon OX9 4QY
 Tel: 01844-351694 Fax: 01844-352554
 Email: enquiries@mauritron.co.uk

| | Nominal Premix Local Frequency | L S B | U S B | CW, AM |
|-------|-----------------------------------|--------------------|--------------------|----------------------|
| 160m | 10.4875–10.9875(MHz) | 10.486–10.986(MHz) | 10.489–10.989(MHz) | 10.4883–12.9883(MHz) |
| 80m | 12.4875–12.9875 | 12.486–12.986 | 12.489–12.989 | 12.4883–12.9883 |
| 40m | 15.9875–16.4875 | 15.986–16.486 | 15.989–16.489 | 15.9883–16.4883 |
| 30m | 18.9875–19.4875 | 18.986–19.486 | 18.989–19.489 | 18.9883–19.4883 |
| 20m | 22.9875–23.4875 | 22.986–23.486 | 22.989–23.489 | 22.9883–23.4883 |
| 17m | 26.9875–27.4875 | 26.986–27.486 | 26.989–27.489 | 26.9883–27.4883 |
| 15m | 29.9875–30.4875 | 29.986–30.486 | 29.989–30.489 | 29.9883–30.4883 |
| 12m | 33.4875–33.9875 | 33.486–33.986 | 33.489–33.989 | 33.4883–33.9883 |
| 10m A | 36.9875–37.4875 | 36.986–37.486 | 36.989–37.489 | 36.9883–37.4883 |
| 10m B | 37.4875–37.9875 | 37.486–37.986 | 37.489–37.989 | 37.4883–37.9883 |
| 10m C | 37.9875–38.4875 | 37.986–38.486 | 37.989–38.489 | 37.9883–38.4883 |
| 10m D | 38.4875–38.9875 | 38.486–38.986 | 38.489–38.989 | 38.4883–38.9883 |

Table 4

HP5082 - 7623x6

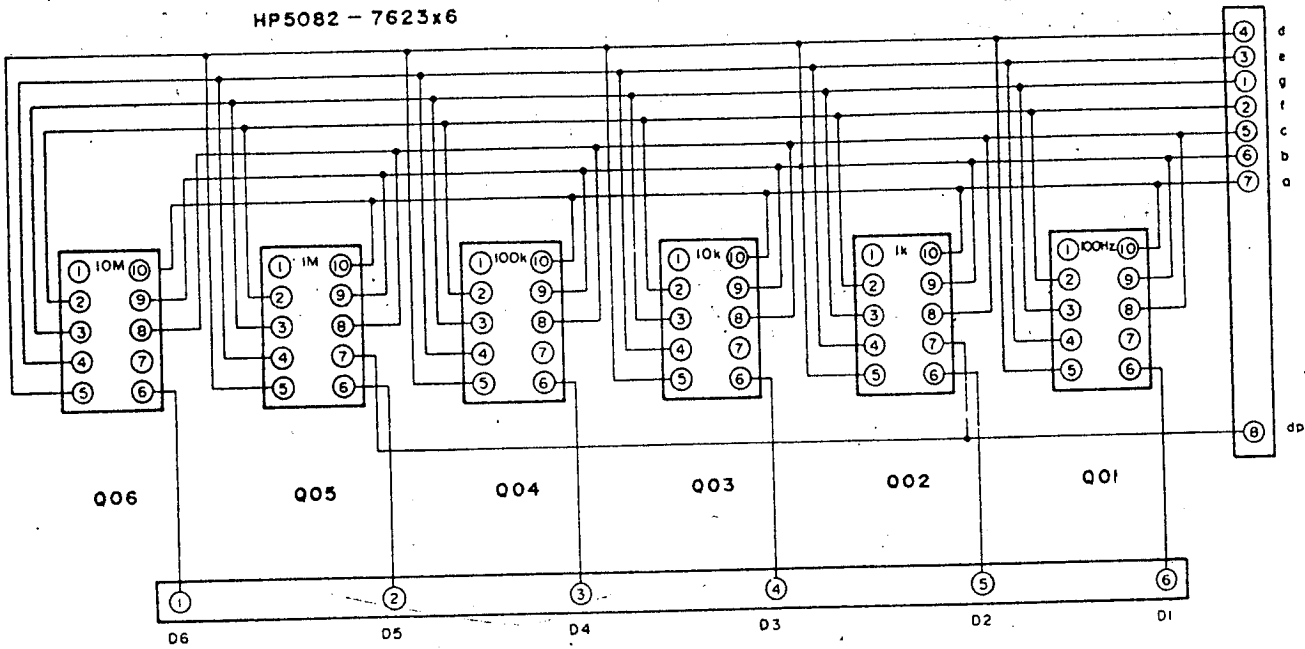

DISPLAY UNIT PB-2098

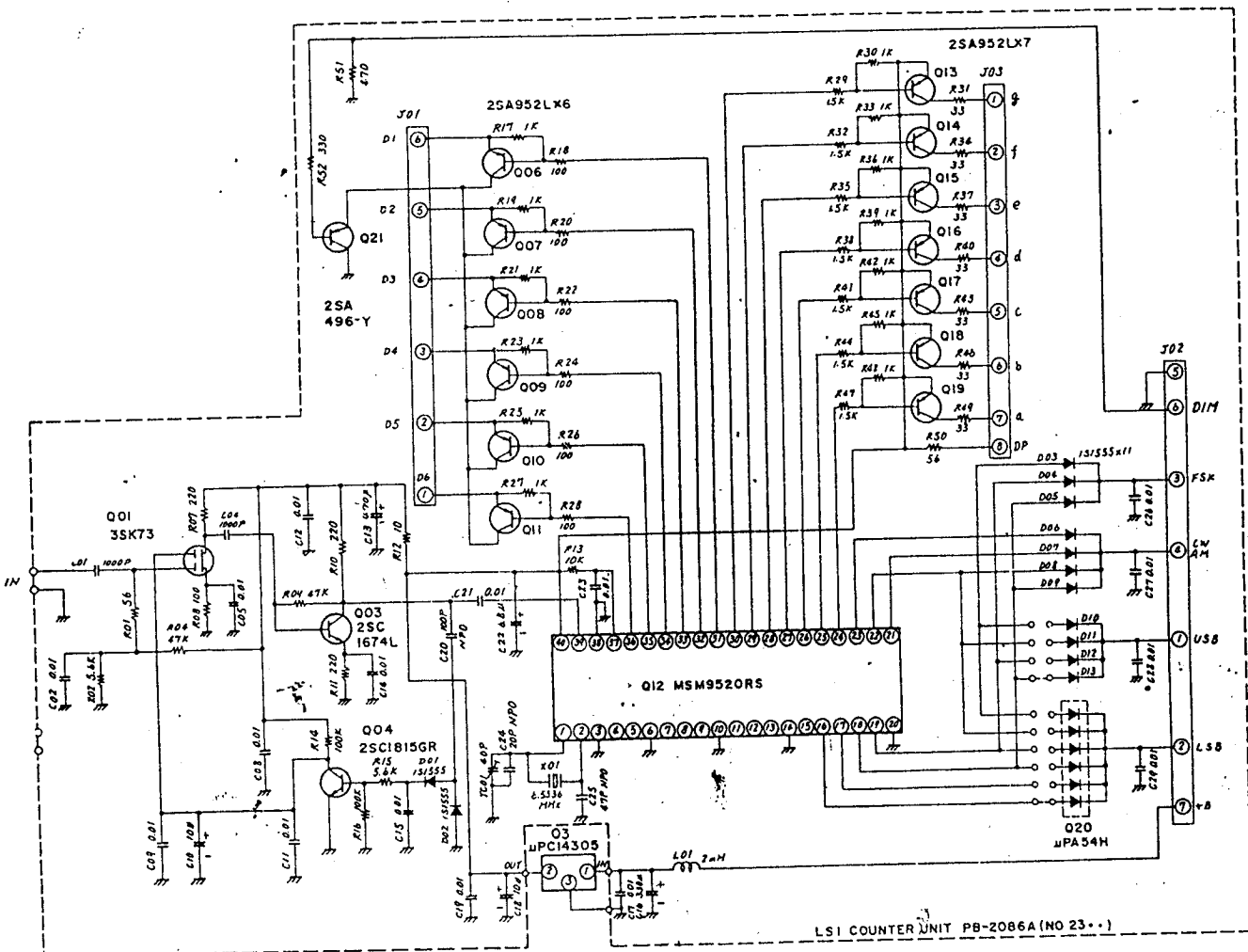

DISPLAY/COUNTER UNIT

POWER SUPPLY

The power supply is designed to operate from 100/110/117/200/220/234 volts AC. A DC-DC converter is an available option, providing operation from 13.5 volts DC. Insertion of the appropriate power plug into the rear panel receptacle makes the necessary connections for AC or DC operation.

When the transceiver is operated from a DC 13.5 volt power source, using the optional DC-DC converter, transistors Q₃₂₀₁ and Q₃₂₀₂ (T20A6) function as a low frequency oscillator, providing AC voltage at approximately 80 Hz to the power transformer. All of the tube heaters receive their power through the HEATER switch on the front panel. When the HEATER switch is OFF, voltage is still supplied to the receiver section, thus allowing continuous reception with reduced power consumption. The heaters of the two 6146B are connected in series to operate at 12 volts DC.

The 14 volt AC power delivered from the secondary winding of the power transformer is rectified by D₉₀₅ and D₉₀₆ (V06B). Voltage regulators Q₁ (2SB616), Q₉₀₁ (78L12), and Q₉₀₃ (2SA495) stabilize the DC supply at 12 volts. The supply voltage is further stabilized at 8 volts by Q₃ (μ PC14308) for delivery to the counter, AF, and other units. The 6 volt supply for the VFO is provided through zener diode D₉₀₈ (WZ061), while the 5 volt supply for the TTL integrated circuits is provided by Q₅₀₅ (78L05).

The power amplifier plate voltage of +800 volts is supplied from the bridge-controlled doubler, located on the RECT. A UNIT, and consisting of D₉₀₁ - D₉₀₄ (10D10).

AC 190 volts is rectified by D₁₀₀₂ (10D10), producing 210 volts for the screen grid supply of the power amplifier tubes. The screen grid voltage for the driver tube is obtained by rectifying 250 volts AC at D₁₀₀₁ (10D10), producing 300 volts. This voltage is dropped to 180 volts by a resistor for delivery to the driver tube screen grid.

The 120 volt AC power from the transformer secondary winding is rectified by D₁₀₀₃ (10D10) in order to obtain -140 volts for the driver and final amplifier tube grid bias.

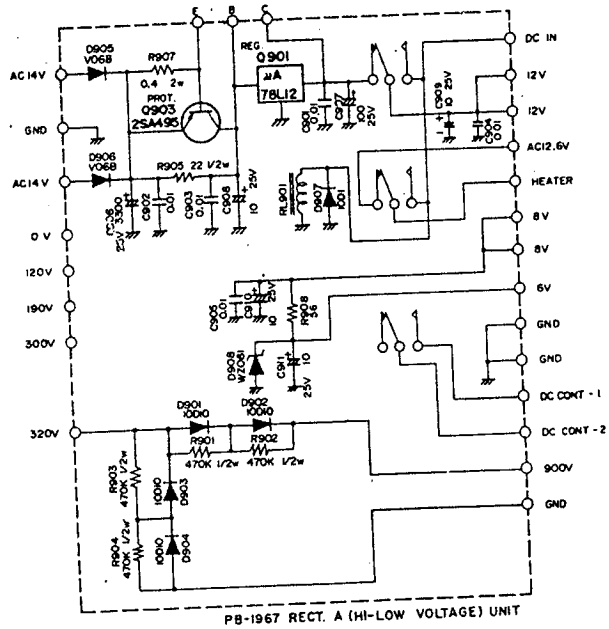

For Service Manuals Contact
MAURITRON TECHNICAL SERVICES
 8 Cherry Tree Rd, Chinnor
 Oxon OX9 4QY
 Tel: 01844-351694 Fax: 01844-352554
 Email: enquiries@mauritron.co.uk

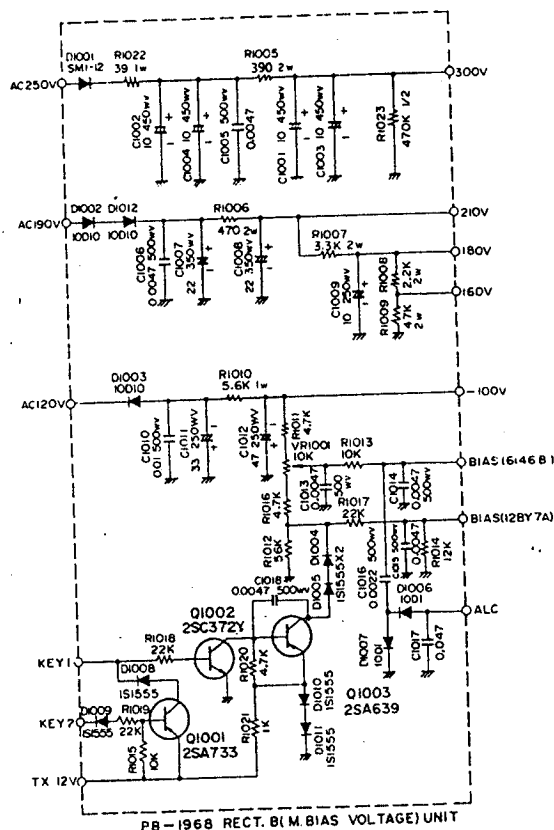

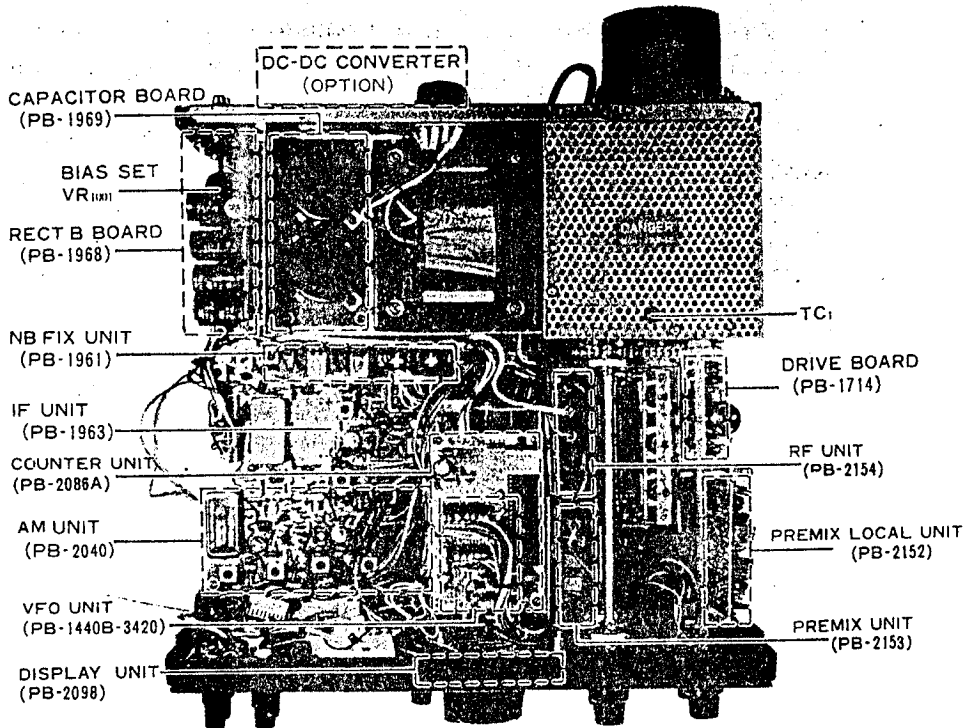

TOP VIEW

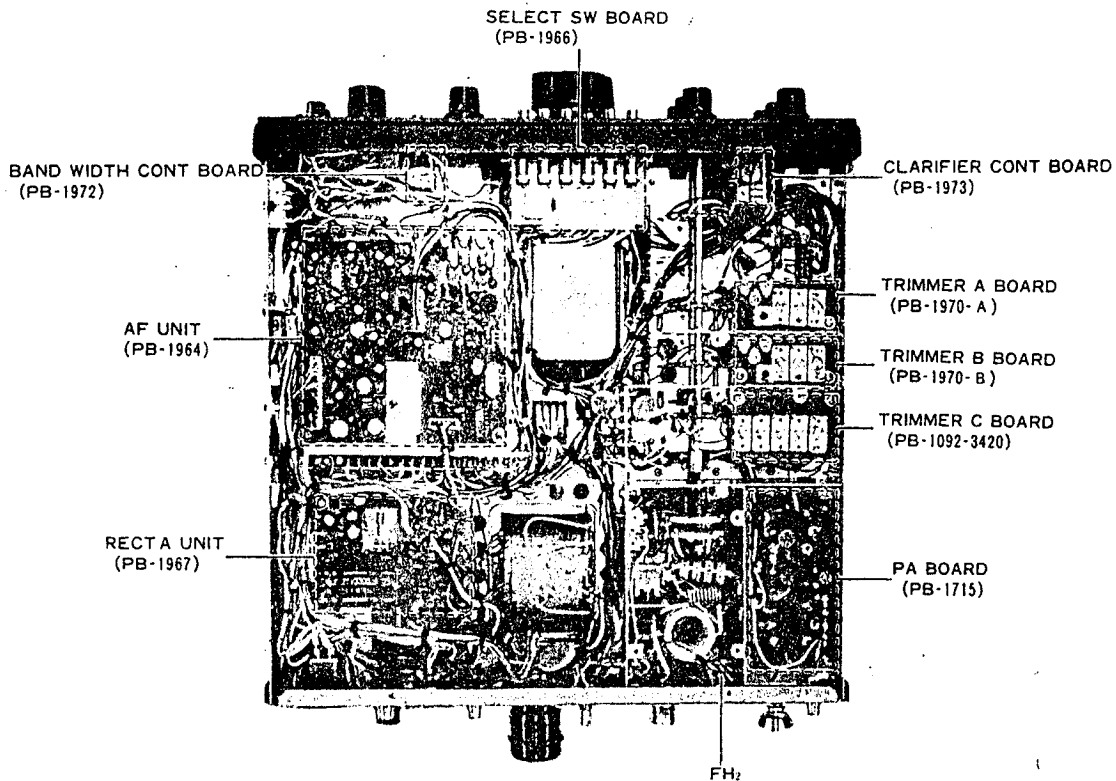

BOTTOM VIEW

MAINTENANCE AND ALIGNMENT

WARNING

DANGEROUS VOLTAGES ARE PRESENT WITHIN THIS TRANSCEIVER. USE EXTREME CAUTION WHEN WORKING ON THE TRANSCEIVER WITH THE COVERS REMOVED. DISCHARGE ALL CAPACITORS BY SHORTING THEM TO GROUND WITH AN INSULATED SCREWDRIVER AFTER POWER HAS BEEN REMOVED. OBSERVE NORMAL SAFETY PRECAUTIONS AT ALL TIMES.

CAUTION

Never operate this transceiver in the transmit mode without a matched antenna or dummy load connected to the antenna receptacle on the rear panel. It is possible to damage the final amplifier tubes and the pi network components if the transmitter is operated without the proper load termination.

GENERAL

This transceiver has been carefully aligned and tested at the factory. With normal use, it should not require other than the usual attention given to electronic equipment. Service or realignment of a major component may require substantial adjustment; under no circumstances, though, should realignment be attempted unless the operation of the transceiver is fully understood, the malfunction has been carefully analyzed, and the fault has definitely been traced to misalignment. Sudden difficulties are almost always caused by component failure rather than misalignment.

Service work should only be performed by experienced personnel, using the proper test equipment.

EQUIPMENT REQUIRED

- (1) RF Signal Generator: Hewlett-Packard Model 606A or equivalent, with one volt output at 50 ohms, and frequency coverage to 30 MHz.
- (2) Vacuum Tube Voltmeter (VTVM): Hewlett-Packard Model 410B or equivalent, with an RF probe good to 40 MHz.
- (3) Dummy Load: Yaesu Model YP-150 or equivalent, with 50 ohm non-reactive load impedance, rated to 150 watts average power.
- (4) AF Signal Generator: Hewlett-Packard Model 200AB or equivalent.
- (5) A general coverage receiver covering 3 to 30 MHz, with a 100 kHz crystal calibrator.
- (6) A frequency counter, Yaesu Model YC-500 or equivalent, with resolution to 0.01 kHz and frequency coverage to 30 MHz.
- (7) An oscilloscope, Hewlett-Packard Model 1740A or equivalent.

AF UNIT ALIGNMENT

VOX Circuit

A. Antitrip level setting

1. Tune in a signal on the FT-101ZD receiver, and adjust the AF GAIN control for a normal listening level. Position the microphone near the speaker, with the MODE switch in the SSB mode. Increase the VOX GAIN control on the front panel until the speaker output causes the VOX relay to switch the transceiver to transmit. Set the ANTITRIP control VR₉, located on the rear apron, to the point that will just prevent the speaker output from tripping the VOX relay.
2. Now place the microphone in the normal operating position, and speak into the microphone to see if your voice will activate the VOX relay. If not, VR₉ may be advanced too far.

B. VOX relay delay setting

1. Adjust the DELAY control VR_{2b}, located on the front panel, for the desired delay time. This may require a different setting for phone and CW operation, owing to differing operating techniques. For CW or phone operation using a footswitch, the VOX GAIN control may be rotated fully counter-clockwise to the PTT position.

CW Sidetone

1. The CW sidetone level may be adjusted by means of VR₁₀, located on the rear apron.

Marker Frequency setting

1. Preset the controls as follows:
BAND 30 m
DIAL 10 MHz
PRESELECT . Peaked for maximum response
MODE TUNE
2. Place the NB/MARK switch in the MARK position. Tune in the WWV or JJY signal, and adjust TC₅₀₁ for an exact zero beat with the carrier of the incoming signal.

Carrier Frequency Adjustment

A. SSB Carrier Point

1. Tune up the transmitter on 20 meters, LSB mode, into a dummy load. Apply a 1 kHz audio signal to the microphone input, and adjust the audio generator output until the transmitter power output is 60 watts, as indicated on the dummy load wattmeter.
2. Shift the audio generator output frequency to 300 Hz, without changing the output level. Adjust TC₅₀₃ for a power output reading of 15 watts on the wattmeter.
3. Shift the MODE switch to USB. Adjust TC₅₀₄ for an identical 15 watt reading on the wattmeter.

For Service Manuals Contact
MAURITRON TECHNICAL SERVICES
8 Cherry Tree Rd, Chinnor
Oxon OX9 4QY
Tel: 01844-351694 Fax: 01844-352554
Email: enquiries@mauritron.co.uk

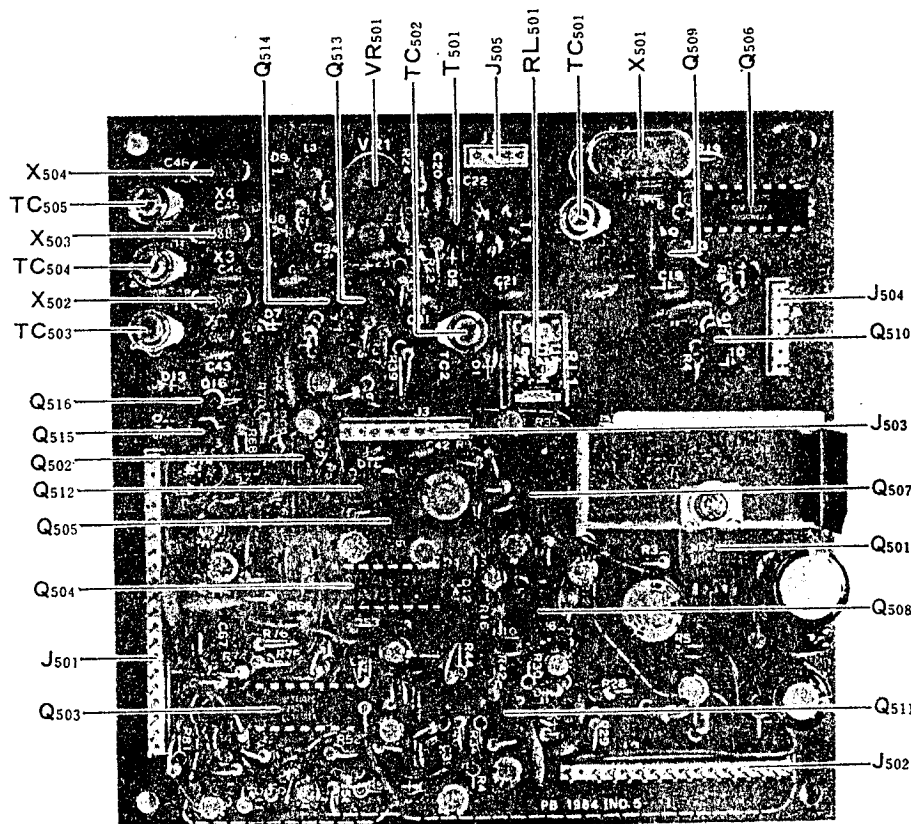

AF UNIT (PB-1964)

4. Recheck the LSB adjustment, as well as the carrier balance adjustment, after performing the carrier point alignment. The background noise, when switching between USB and LSB, should not change.

B. Carrier Balance

1. Tune up the transceiver or 20 meters, USB mode, into a dummy load. Set the main tuning dial to 14.250 MHz. Connect the RF probe of the VTVM to the antenna jack. Disconnect all microphones, etc., from the microphone jack.
2. Activate the transmitter by placing the VOX GAIN control into the MOX position. Adjust VR₅₀₁ and TC₅₀₂ for a minimum VTVM reading.
3. If a VTVM is unavailable, use an external

monitor receiver, tuned to the transmitter frequency, and adjust VR₅₀₁ and TC₅₀₂ for a minimum S-meter reading on the external receiver.

4. This adjustment should be repeated several times on LSB and USB, in order to ensure complete carrier nulling.

C. CW Carrier Point

1. Connect a frequency counter to TP₄₀₂, located on the IF UNIT. Place the MODE switch in the TUNE position.
2. Adjust TC₅₀₅ for a frequency counter reading of exactly 8988.3 kHz.
3. When using the optional CW filter, a substantial loss on transmit, when in the CW-N position, may indicate the need for adjustment as indicated in steps 1 and 2.

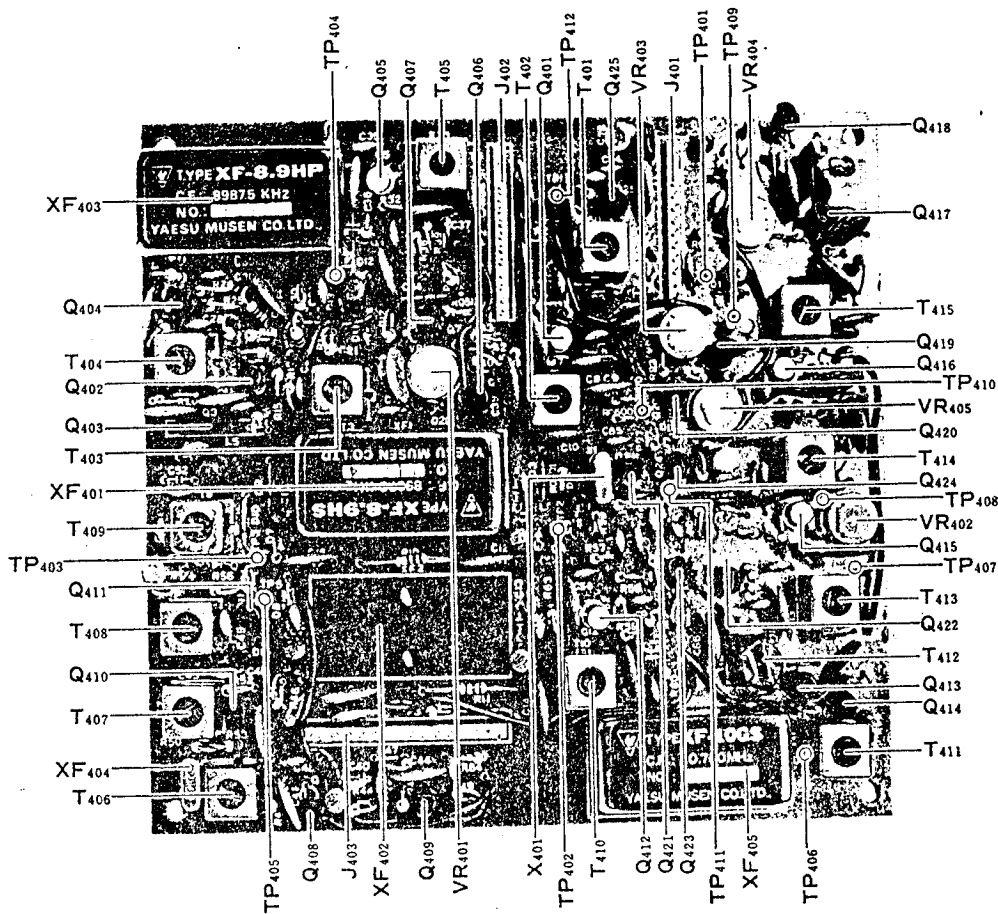

IF UNIT (PB-1963)

IF UNIT ALIGNMENT

S-Meter Sensitivity Adjustment

1. Set the BAND switch to 20 meters, the main dial to 14.250 MHz, and set the RF GAIN fully clockwise.
2. Set the signal generator to 14.250 MHz, and set its output to 6 dB. Tune the signal generator signal on the receiver, and peak the preselector for maximum signal strength. The S-meter should just begin to move with the 6 dB input.
3. Adjust VR₄₀₃ for a reading of 0 on the S-meter.
4. Set the generator output to 100 dB, and adjust VR₄₀₅ for a reading of S9 + 60 dB on the S-meter. Confirm that the preselector is peaked.
5. Return the signal generator output to 6 dB, and recheck the adjustment of VR₄₀₂.

Variable IF Bandwidth Alignment

1. Set the controls as follows:
BAND 20 m
DIAL 14.200 MHz
RF GAIN Fully clockwise
WIDTH switch .. OFF
MODE USB
Peak the preselector for maximum response against the marker signal or background noise.
2. Connect the frequency counter to TP₄₁₁. Adjust VR₁₅₀₁ for a reading of exactly 19.7475 MHz.
3. Place the WIDTH switch ON. Make sure that the WIDTH control is exactly in the 12 o'clock position. Adjust VR₄₀₄ for a reading of exactly 19.7475 MHz on the frequency counter.
4. Switch between USB and LSB, and observe the background noise. If there is any difference, adjust VR₁₅₀₁ until the background noise is the same.

ALC Meter Alignment

1. On any band, set the MODE switch to USB. Set the meter switch to ALC.
2. With no speech input, activate the transmitter. Adjust VR₄₀₁ for a 0 reading on the ALC meter scale.

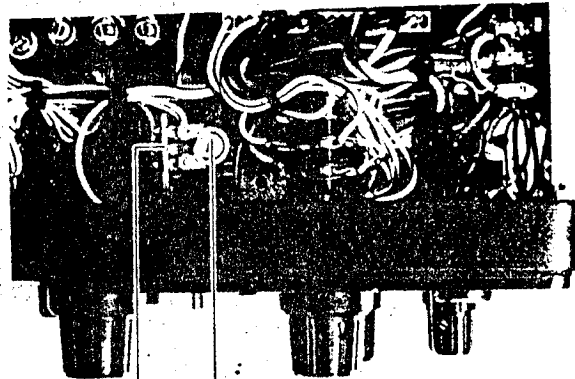

BAND WIDTH CONTROL UNIT
(PB-1972)

RECTIFIER B UNIT

Bias Adjustment

1. Set the MODE switch to USB or LSB, and set the MIC GAIN control fully counterclockwise.
2. Place the METER switch in the IC position, and set the VOX GAIN control to VOX. Adjust the BIAS control located on the RECT, B UNIT (PB-1968) VR₁₀₀₁, for a reading of 50 mA. For 10 watt models, the correct meter reading is 25 mA.

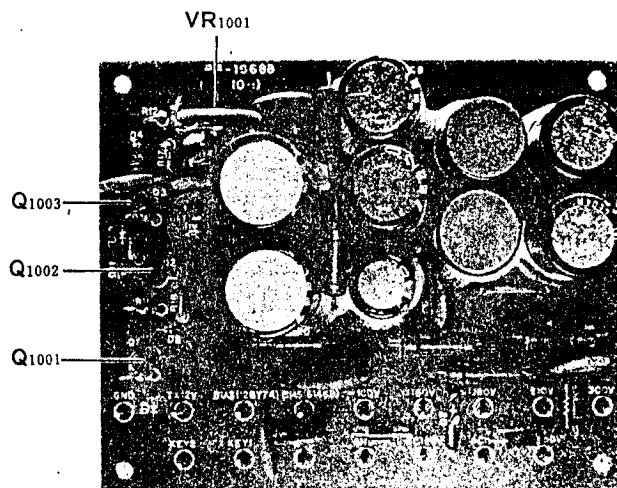

RECT B UNIT (PB-1968)

For Service Manuals Contact
MAURITRON TECHNICAL SERVICES
8 Cherry Tree Rd, Chinnor
Oxon OX9 4QY
Tel: 01844-351694 Fax: 01844-352554
Email: enquiries@mauritron.co.uk

VFO UNIT

The VFO UNIT is very critical in its adjustment. As well, this is not an area which should ever require alignment. Questions regarding drift, etc., usually can be traced to other areas of the transceiver (instability in the supply voltage, etc.). For this reason, all cases regarding VFO repair should be referred to an experienced service technician.

The following components are of interest from a service standpoint:

TC₈₀₁ is the band set trimmer.

TC₈₀₂ is the VFO level set trimmer.

To confirm proper VFO injection, connect the VTVM to the VFO output. Adjust TC₈₀₂ for a reading of 100 mV.

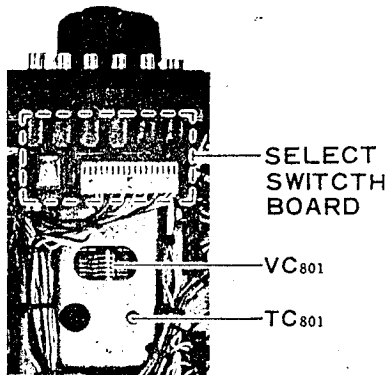

| BAND | CRYSTAL | FREQUENCY | TRANS-FORMER |
|-------|------------------|------------|------------------|
| 160m | X ₆₀₁ | 15.9875MHz | T ₆₀₁ |
| 80m | X ₆₀₂ | 17.9875 | T ₆₀₂ |
| 40m | X ₆₀₃ | 21.4875 | T ₆₀₃ |
| 30m | X ₆₀₄ | 24.4875 | T ₆₀₄ |
| 20m | X ₆₀₅ | 28.4875 | T ₆₀₅ |
| 17m | X ₆₀₆ | 32.4875 | T ₆₀₆ |
| 15m | X ₆₀₇ | 35.4875 | T ₆₀₇ |
| 12m | X ₆₀₈ | 38.9875 | T ₆₀₈ |
| 10m A | X ₆₀₉ | 42.4875 | T ₆₀₉ |
| 10m B | X ₆₁₀ | 42.9875 | T ₆₁₀ |
| 10m C | X ₆₁₁ | 43.4875 | T ₆₁₁ |
| 10m D | X ₆₁₂ | 43.9875 | T ₆₁₂ |

Table 6

NB-FIX UNIT

Fixed Channel Frequency Alignment

When the optional fixed channel crystals are being used, they may be placed exactly on the correct frequency by adjusting TC₂₀₁ (for channel 1) and TC₂₀₂ (for channel 2). Confirmation of the correct frequency may be made with an external receiver or by loosely coupling a probe from the frequency

counter to the transmitter output. A 1-turn loop is usually sufficient to provide indication on the counter.

PREMIX LOCAL UNIT

Premix Local Alignment

1. Connect the RF probe of the VTVM to pin 1 of MJ₃.
2. Refer to Table 6, and adjust the appropriate transformer for a level of 300 mV for each band and crystal, as shown in the table.

PREMIX UNIT

For this alignment, a wideband (not peak) sweep generator, as well as an oscilloscope, should be used.

1. Press the EXT select switch. Apply 5.0 - 5.5 MHz sweep output to the VFO output terminal at the rear apron external VFO jack. Connect a high-impedance probe of an oscilloscope to J₃₀₁.
2. Adjust the transformers shown in Table 7 for a flat response across the entire passband. If you have never adjusted a bandpass filter previously, this may take some practice. Perform the adjustments on each band, according to the chart.

| BAND | TRANS-FORMER | PASSBAND |
|-------|-------------------------------------|----------------|
| 160m | T ₃₀₁ , T ₃₀₂ | 10.4-11.0(MHz) |
| 80m | T ₃₀₃ , T ₃₀₄ | 12.4-13.0 |
| 40m | T ₃₀₅ , T ₃₀₆ | 15.9-16.5 |
| 30m | T ₃₀₇ , T ₃₀₈ | 18.9-19.5 |
| 20m | T ₃₀₉ , T ₃₁₀ | 22.9-23.5 |
| 17m | T ₃₁₁ , T ₃₁₂ | 26.9-27.5 |
| 15m | T ₃₁₃ , T ₃₁₄ | 29.9-30.5 |
| 12m | T ₃₁₅ , T ₃₁₆ | 33.5-34.0 |
| 10m A | T ₃₁₇ , T ₃₁₈ | 36.9-39.0 |

Table 7

AM UNIT

1. Set the BAND switch to 40, the MODE switch to AM, and the DRIVE control to the 3 o'clock position. Tune up the transmitter in the usual fashion. Now adjust the core of T₂₄₀₁ for maximum power output into the dummy load/wattmeter.
2. Connect a frequency counter to TP₂₄₀₂. Adjust TC₂₄₀₁ for a counter reading of exactly 8988.3 kHz while transmitting.
3. Connect the RF probe of the VTVM to TP₂₄₀₁, and adjust TC₂₄₀₂ for a reading of 50 mV while transmitting.

For Service Manuals Contact
MAURITRON TECHNICAL SERVICES
 8 Cherry Tree Rd, Chinnor
 Oxon OX9 4QY
 Tel: 01844-351694 Fax: 01844-352554
 Email: enquiries@mauritron.co.uk

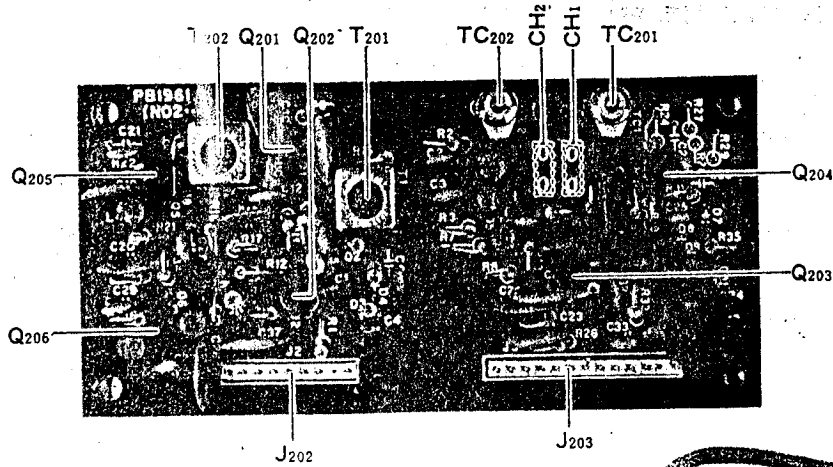

NB-FIX UNIT (PB-1961)

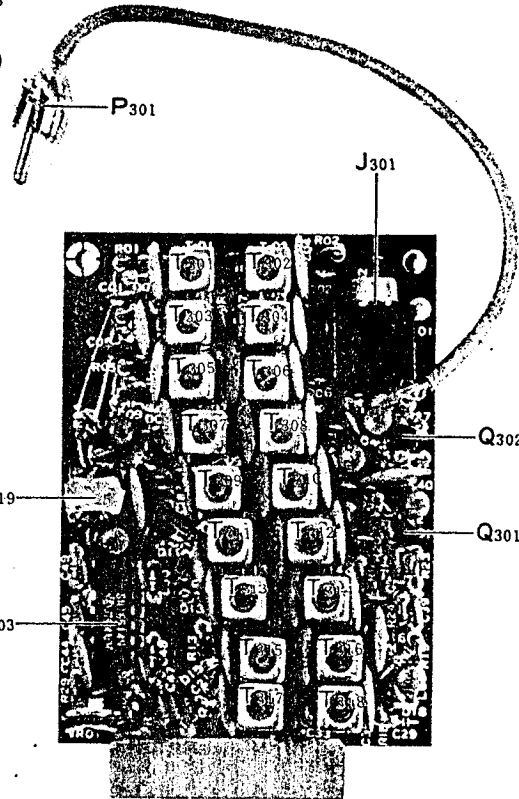

PREMIX LOCAL (XTAL) UNIT (PB-2153)

- | | | |
|---------------------------------|-------------------------------|-------|
| (160m)(80m)(40m)(30m)(20m)(17m) | Q 606 | Q 607 |
| | T 606 | T 607 |
| | X 606 | X 607 |
| | Q 605 | Q 608 |
| | T 605 | T 608 |
| | X 605 | X 608 |
| | Q 604 | Q 609 |
| | T 604 | T 609 |
| | X 604 | X 609 |
| | Q 603 | Q 610 |
| | T 603 | T 610 |
| | X 603 | X 610 |
| | Q 602 | Q 611 |
| | T 602 | T 611 |
| | X 602 | X 611 |
| | Q 601 | Q 612 |
| | T 601 | T 612 |
| | X 601 | X 612 |
| | (10mD)(10mC)(10mB)(10mA)(12m) | |

PREMIX UNIT (PB-2152)

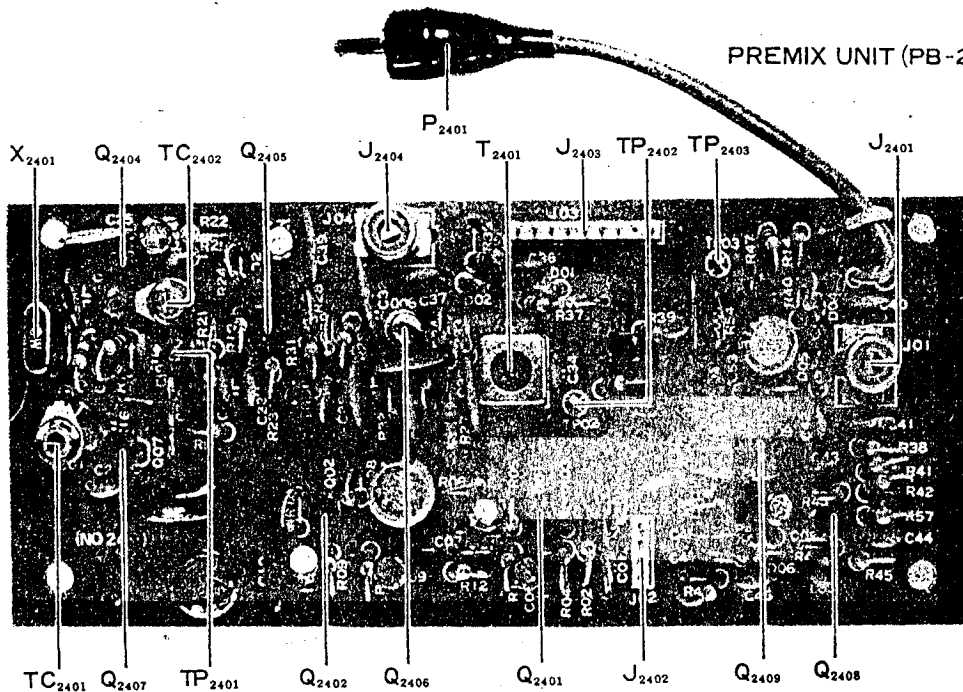

AM UNIT (PB-2040)

TRANSMIT RF/IF TRANSFORMER ALIGNMENT

- (1) Connect a dummy load to the antenna jack, and connect an audio signal generator to the microphone input. Tune up the transmitter at 14.2 MHz, and adjust the audio generator output for approximately 50 watts output into the dummy load, single-tone, SSB mode.
- (2) Peak T_{401} - T_{403} and T_{405} (IF UNIT) for maximum power output. Switch the RF processor on, and adjust the COMP LEVEL control for approximately 50 watts output. Peak T_{404} for maximum power output.

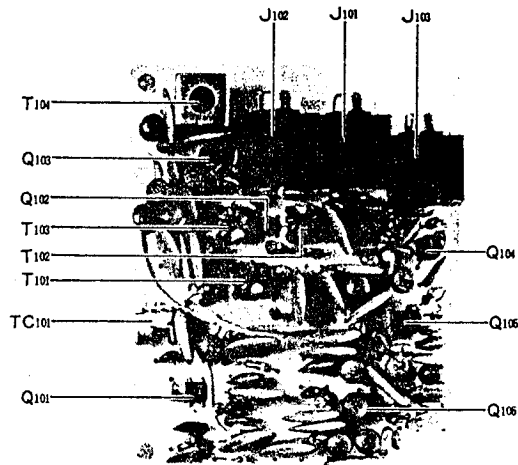

RF UNIT (PB-2154)

RECEIVER RF/IF/NB TRANSFORMER ALIGNMENT

- (1) Tune in the marker generator signal at 14.2 MHz, with a dummy load connected to the antenna jack. Peak the preselector for maximum S-meter indication.
- (2) Peak T_{104} (RF UNIT) for maximum S-meter indication.
- (3) Peak T_{406} - T_{411} and T_{413} - T_{415} for maximum S-meter indication.
- (4) Connect the RF probe of a VTVM to the collector of Q_{202} (NB-FIX UNIT). Reduce the RF GAIN control somewhat, and tune T_{201} and T_{202} for a dip in the VTVM indication. If no dip is observed, reduce the RF GAIN control further.

CLARIFIER ALIGNMENT

1. Tune in the marker generator signal on any band, and peak the preselector on the marker signal.
2. With the CLARIFIER control OFF, make sure that the CLARIFIER knob is exactly at the 12 o'clock position. Note the tone of the marker signal.
3. Switch the RX CLARIFIER to ON, and observe the tone of the marker signal. If it is different from when the clarifier was turned off, adjust VR₁₈₀₁ for an identical tone with the CLARIFIER knob exactly on the zero mark.

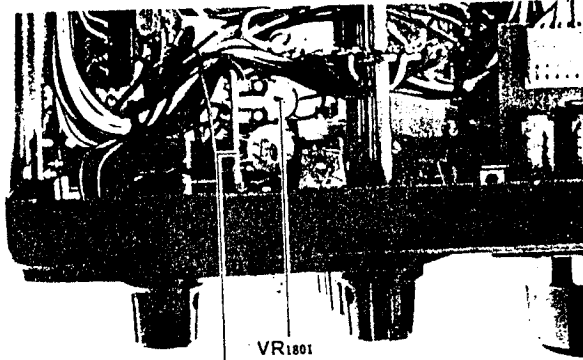

CLARIFIER
CONTROL UNIT
(PB-1973)

For Service Manuals Contact
MAURITRON TECHNICAL SERVICES
8 Cherry Tree Rd, Chinnor
Oxon OX9 4QY
Tel: 01844-351694 Fax: 01844-352554
Email: enquiries@mauritron.co.uk

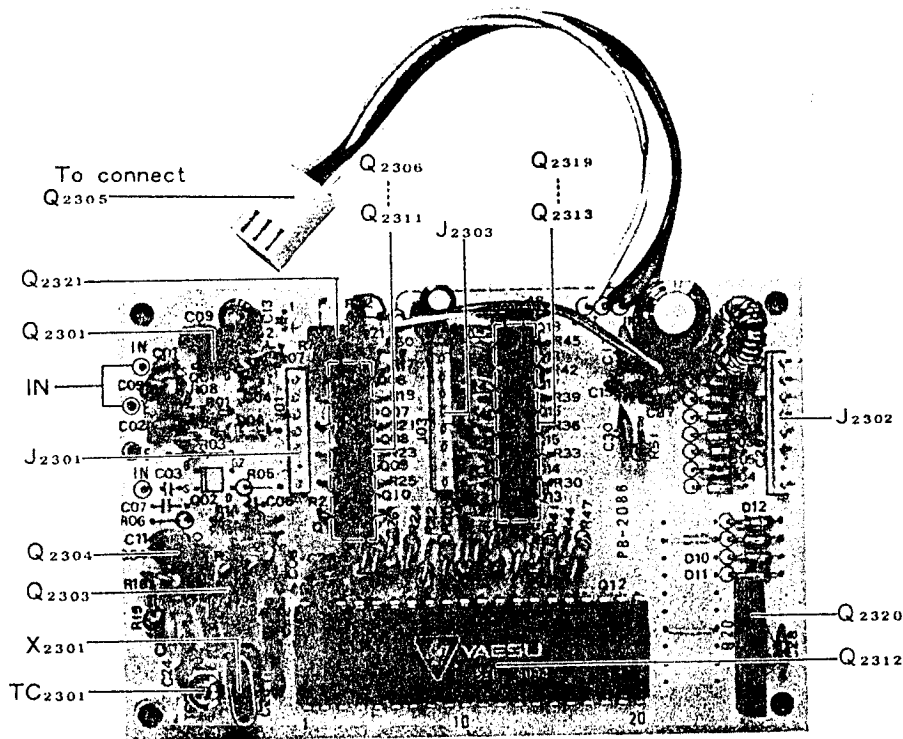

COUNTER UNIT (PB-2086A)

FINAL AMPLIFIER NEUTRALIZATION

Important Note: For this alignment, use a NON-METALLIC tuning wand.

1. Set the BAND switch to 10C, set the tuning dial to 29 MHz, and tune into a dummy load for approximately 70% full output power.
2. Set the METER switch to IC, and observe the dip in the cathode current. The dip should occur at the same point that maximum power output (measured on the dummy load wattmeter) occurs. If this is not the case, adjust TC₁; located inside the final amplifier cage, for the required coincidence of maximum power output and dip on the IC meter.

CAUTION: HIGH VOLTAGES ARE PRESENT ON THE UNDERSIDE OF THE CHASSIS AND INSIDE THE FINAL AMPLIFIER COMPARTMENT. USE GREAT CARE WHILE MAKING ADJUSTMENTS IN AREAS OF EXPOSED WIRING.

Note: The final amplifier enclosure must be in place to provide the required RF shielding during the neutralization procedure.

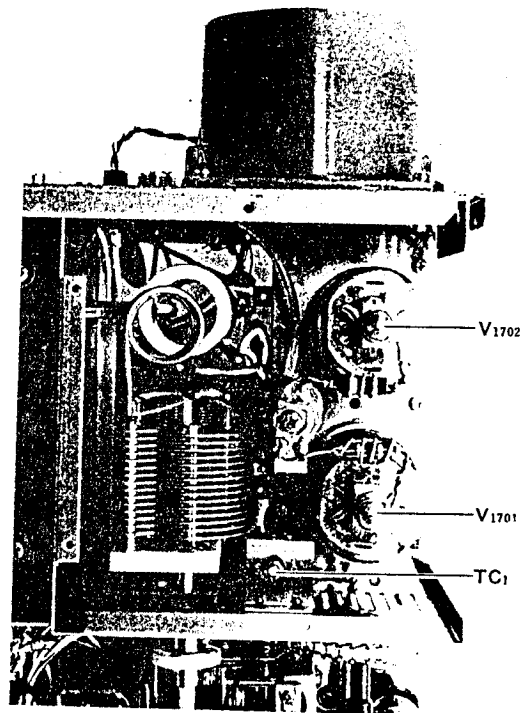

Final Amplifier Compartment

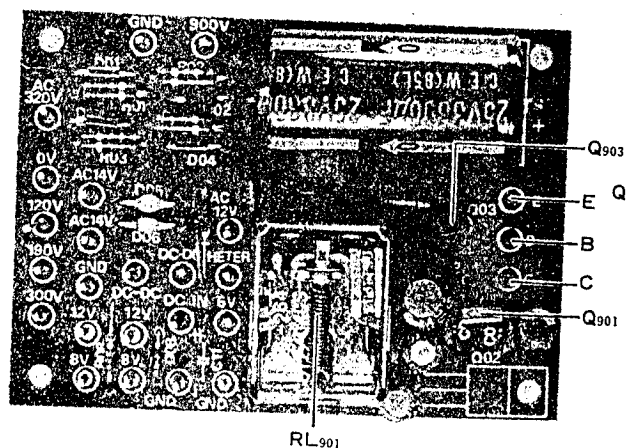

RECT A UNIT (PB-1967)

| ***** LED BOARD ***** | | | | CAPACITOR | | | |
|-------------------------------|-----------|-----------------------------|-------------|--|-----------|-----------------------------|-------------------|
| PB-1390 | F0001390 | P.C. Board | | C138 | K02179003 | Ceramic | 50V CH 2 pF |
| D9 | G2090060 | GD4-203-SR1 | | C106 | K02172040 | " " " | 4 pF |
| | | | | C125, 126 | K00175680 | " " SL | 68 pF |
| | | | | C103 | K00175101 | " " " | 100 pF |
| | | | | C102, 104, 116, 119-121, 130, 131, 135, 140 | K13170103 | " " " | 0.01 μF |
| | | | | C101, 105, 107-115, 117, 118, 122-124, 127-129, 132-134, 136, 137, 139 | K13170473 | " " " | 0.047 μF |
| RF UNIT | | | | | | | |
| Symbol No. | Parts No. | Description | | | | | |
| PB-2154 | F0002154 | Printed Circuit Board | | | | | |
| | C0021540 | P.C.B. with components | | | | | |
| | | | | | | | |
| IC, FET & TRANSISTOR | | | | | | | |
| Q102 | G2090135 | IC (Ring Module) ND487C2-3R | | | | | TRIMMER CAPACITOR |
| Q106 | G4800400M | FET | 3SK40M | TC101 | K91000019 | ECV-1ZW 10 x 40 | 10 pF |
| Q101 | G4800510C | " | 3SK51-03 | | | | |
| Q103 | G3090019 | " | J310 | | | | INDUCTOR |
| Q104, 105 | G3324070 | TR | 2SC2407 | L107 | L0020491 | | 0.32 μH |
| | | | | L108, 112 | L1190033 | FL5H-820K | 82 μH |
| | | | | L102, 103, 105, 106, 113, 114 | L1190016 | FL5H-101K | 100 μH |
| | | DIODE | | | | | |
| D110 | G2010070 | Ge | 1S1007 | L104, 109, 111 | L1190020 | FL5H-151K | 150 μH |
| D103, 104 | G2015550 | Si | 1S1555 | | | | |
| D101, 102, 105-109 | G2090027 | " | 1SS53 | L101, 110, 115 | L1190038 | FL5H-271K | 270 μH |
| | | | | | | | TRANSFORMER |
| | | | | T101-103 | L0020788A | | |
| | | RESISTOR | | T104 | L0020221 | | |
| R122, 131, | J00245479 | Carbon film | ¼W VJ 4.7 Ω | | | | JACK |
| R109, 110, 115, 116, 124, 125 | | " " " | " " 10 Ω | J101-103 | P1090018 | | SQ-3081 |
| | | | | | | | |
| | | | | NB-FIX UNIT | | | |
| Symbol No. | Parts No. | Description | | | | | |
| R135 | J00245560 | " " " | " " 56 Ω | | | | |
| R106, 107, 113, 114, 139, 140 | J00245101 | " " " | " " 100 Ω | | C0019610 | NB-FIX unit with components | |
| | | | | | PB-1961B | F0001961B P.C. Board | |
| R108, 117, 126 | J00245121 | " " " | " " 120 Ω | | | | TRANSISTOR |
| | | | | Q201-204 | G3303720Y | 2SC372Y | |
| R121, 130 | J00245151 | " " " | " " 150 Ω | Q205, 206 | G3315830 | 2SC1583 | |
| R123, 132 | J00245221 | " " " | " " 220 Ω | | | | |
| R136 | J00245331 | " " " | " " 330 Ω | | | | DIODE |
| R119, 128 | J00245561 | " " " | " " 560 Ω | D201-204 | G2090029 | Ge 1N60 | |
| R105, 111, 112, 120, 129 | J00245102 | " " " | " " 1 kΩ | D205-209 | G2015550 | Si 1S1555 | |
| | | | | | | | RESISTOR |
| R118, 127 | J00245152 | " " " | " " 1.5 kΩ | R208, 216, 224, 230, 238, 239, | J00245101 | Carbon film 1/4W VJ 100 Ω | |
| R141 | J00245222 | " " " | " " 2.2 kΩ | R204 | J00245221 | " " " " 220 Ω | |
| R102 | J00245272 | " " " | " " 2.7 kΩ | R222, 236 | J00245471 | " " " " 470 Ω | |
| R104, 134 | J00245562 | " " " | " " 5.6 kΩ | R231-233, 235 | J00245561 | " " " " 560 Ω | |
| R138 | J00245103 | " " " | " " 10 kΩ | R206, 215, 221, 234, 237 | J00245102 | " " " " 1 kΩ | |
| R137 | J00245183 | " " " | " " 18 kΩ | | | | |
| R103, 133 | J00245393 | " " " | " " 39 kΩ | | | | |
| R101 | J00245225 | " | 2.2 MΩ | R207 | J00245222 | " " " " 2.2 kΩ | |

| | | | | | | | RESISTOR | | |
|--|-----------|-----------------------------|----------|----------|--|-----------|---------------|---------|----------|
| R210, 240 | J00245472 | Carbon film | 1/4W VJ | 4.7 kΩ | | | | | |
| R205,209,218 | J00245562 | " " | " " | 5.6 kΩ | R323 | J00245100 | Carbon film | 1/4W VJ | 10 Ω |
| R202,203,212, 214,225,226 | J00245103 | " " | " " | 10 kΩ | R331 | J00245680 | " " | " " | 68 Ω |
| R201,220,223 | J00245153 | " " | " " | 15 kΩ | R301, 303, 305, 307, 309, 311, 313, 315, 317, 332, 333 | J00245101 | " " | " " | 100 Ω |
| R211,213,219 | J00245223 | " " | " " | 22 kΩ | | | | | |
| R217 | J00245683 | " " | " " | 68 kΩ | | | | | |
| | | CAPACITOR | | | | | | | |
| C201,216-218 | K30176331 | Dipped mica | 50WV | 330 pF | R322, 324, 327, 328 | J00245221 | " " | " " | 220 Ω |
| C234, 236 | K30176471 | " " | " " | 470 pF | | | | | |
| C235 | K30176821 | " " | " " | 820 pF | R319, 334 | J00245152 | " " | " " | 1.5 kΩ |
| C208, 209 | K02175150 | Ceramic | 50WV NPO | 15 pF | R329, 330 | J00245222 | " " | " " | 2.2 kΩ |
| C206 | K00179005 | " " | SL | 20 pF | R302, 304, 308, 310, 312, 314, 316, 318, 321, 325, 326 | J00245103 | " " | " " | 10 kΩ |
| C204 | K00175101 | " " | " " | 100 pF | | | | | |
| C202,203,205, 211,212,221, 225-227, 229-233 | K13170103 | " " | " " | 0.01 μF | | | | | |
| C207,210,213, 215,219,220, 223,224,228, 237 | K13170473 | " " | " " | 0.047 μF | R306 | J00245153 | " " | " " | 15 kΩ |
| | | | | | R320 | J00245333 | " " | " " | 33 kΩ |
| | | | | | | | POTENTIOMETER | | |
| | | | | | VR301 | J50710502 | V10K-8-1-2 | | 5 kΩB |
| | | | | | | | CAPACITOR | | |
| C214 | K40170105 | Electrolytic | 50WV | 1 μF | C335 | K30176271 | Dipped mica | 50WV | 270 pF |
| C238 | K40140475 | " " | 10WV | 4.7 μF | C331 | K30176331 | " " | " " | 330 pF |
| | | TRIMMER CAPACITOR | | | C311, 315, 319 | K30176561 | " " | " " | 560 pF |
| TC201, 202 | K91000016 | ECV-1ZW | 50 x 32 | 50 pF | C323, 327 | K30176680 | " " | " " | 680 pF |
| | | INDUCTOR | | | C301, 305, 309, 313, 317, 321, 325, 329, 333, 337- 339, 341, 343, 345- 351 | K13170103 | Ceramic | " " | 0.01 μF |
| L207, 208 | L1190007 | FL-4H | 1R8K | 1.8 μH | | | | | |
| L204-206 | L1190016 | FL-5H | 101K | 100 μH | | | | | |
| L201-203 | L1190017 | FL-5H | 102K | 1 mH | | | | | |
| | | TRANSFORMER | | | | | | | |
| T201, 202 | L0020140 | R12-4170 | | | | | | | |
| | | CRYSTAL SOCKET | | | C302, 304, 306, 308, 312, 314, 316, 318, 320, 322, 324, 326, 328, 330, 332, 334, 336, 340, 342, 344 | K13170103 | Ceramic | 50WV | 0.047 μF |
| XS201 | P3090025 | S-14 | 2P | | | | | | |
| | | MINI CONNECTOR | | | | | | | |
| J201 | P0090037 | 5048-08A | | | | | | | |
| J202 | P0090038 | 5048-12A | | | | | | | |
| | | | | | C303, 307 | K50177102 | Mylar | " " | 0.001 μF |
| PREMIX UNIT | | | | | | | | | |
| Symbol No. | Parts No. | Description | | | | | INDUCTOR | | |
| | C0021520 | PREMIX unit with components | | | L302 | L1190007 | FL4H-1R8M | | 1.8 μH |
| PB-2152 | F0002152 | P.C. Board | | | L303 | L1190023 | FL5H-220K | | 22 μH |
| | | | | | L301, 304- 306 | L1190017 | FL5H-102K | | 1 mH |
| | | IC, FET, TRANSISTOR | | | | | | | |
| Q303 | G1090062 | IC | SN76514N | | | | | | |
| Q301 | G3319230R | TR | 2SC1923R | | | | TRANSFORMER | | |
| | | | | | T301, 302 | L0020500 | | | |
| | | | | | T303, 304 | L0020501 | | | |
| | | DIODE | | | T305, 306 | L0020502 | | | |
| D301-318 | G2090027 | Si | 1SS53 | | T307, 308 | L0020835 | | | |

| | | | | | |
|---------------------------------|-----------|----------------------------|--|-----------|--|
| T309, 310 | L0020504 | | XF403 | H1100890 | XF8.9HP |
| T311, 312 | L0020836 | | XF404 | H1100470 | 8.9M20A |
| T313, 314 | L0020837 | | XF405 | H1100900 | XF10GS (XF-10HW) |
| T315, 316 | L0020838 | | | | THERMISTOR |
| T317, 318 | L0020839 | | TH401 | G9090003 | D-33A |
| T319 | L0020210 | | | | RESISTOR |
| | | | R0517, 0518, 0520 | J00245220 | Carbon film 1/4W VJ 22 Ω |
| | | JACK | | | |
| J301 | P1090018 | SQ3081 | R410, 411 | J01245101 | " " " TJ 100 Ω |
| P301 | P0090045 | SQ4052 | R402,408,422, 423,437,439, 444,446,463, 464,469,475, 482,483,497 | J00245101 | " " " VJ 100 Ω |
| | | | R419,425,447, 451,486, 0507,0508 | J00245221 | " " " " 220 Ω |
| IF UNIT | | | | | |
| Symbol No. | Parts No. | Description | | | |
| | C0019630 | IF unit with components | R0502 | J00245331 | " " " " 330 Ω |
| PB-1963C | F0001963C | P.C. Board | | J00245391 | 390 Ω |
| | | | R443 | J00245471 | " " " " 470 Ω |
| | | | R474,480,0522 | J00245561 | " " " " 560 Ω |
| | | | R467, 468 | J00245681 | " " " " 680 Ω |
| | | | | J00245821 | " " " " 820 Ω |
| | | IC, FET, TRANSISTOR | | | |
| Q403 | G1090063 | IC TA7060P | R406,416,428, 437,440,442, 449,453,457, 459,462,488, 494,0504, 0506,0515 | J00245102 | " " " " 1 kΩ |
| Q406 | G3800190B | FET 2SK19BL | | | For Service Manuals Contact MAURITRON TECHNICAL SERVICES 8 Cherry Tree Rd. Chinnor Oxon OX9 4QY Tel:- 01844-351694 Fax:- 01844-352554 Email:- enquiries@mauritron.co.uk |
| Q402,413,414, 419, 425 | G3800190G | " 2SK19GR | | | |
| Q401,405,412, 415, 416 | G4800510C | " 3SK51-03 | | | |
| Q408 | G3090019 | " J310 | R429 | J00245122 | |
| Q407, 420 | G3105641 | TR 2SA564A | R495 | J00245152 | " " " " 1.5 kΩ |
| Q404,409,410, 417, 418, 422-424 | G3303720Y | " 2SC372Y | R0516 | J01245152 | " " " TJ 1.5 kΩ |
| | | | R454,455,458, 0510 | J00245222 | " " " VJ 2.2 kΩ |
| Q421 | G3305350A | " 2SC535A | R460 | J00245272 | " " " " 2.7 kΩ |
| Q411 | G3090005 | " MPSA13 | R401,409,412, 413,431,456, 496,0511 | J00245332 | " " " " 3.3 kΩ |
| | | | R426,427,476 | J00245472 | " " " " 4.7 kΩ |
| | | | R403,445,478, 489 | J00245562 | " " " " 5.6 kΩ |
| | | DIODE | | | |
| D416, 417 | G2090029 | Ge 1N60 | R434, 450 | J00245682 | " " " " 6.8 kΩ |
| D405-408, 414, 421 | G2010070 | " (GB) 1S1007 | R404,407,420, 421,424,436, 471,477,481, 484,485,491, 492, 0501, 0509, 0512 | J00245103 | " " " " 10 kΩ |
| D401-404, 409-413, 419, 424 | G2015550 | Si 1S1555 | | | |
| D418 | G2022090 | Varactor 1S2209 | | | |
| D422 | G2090040 | " FC63 | | | |
| D420, 423 | G2090010 | Zener WZ090 | R433 | J01245103 | " " " TJ 10 kΩ |
| | | | R470 | J00245123 | " " " VJ 12 kΩ |
| | | | R415,498,499 499 | J00245153 | " " " " 15 kΩ |
| | | | R414 | J00245273 | " " " " 27 kΩ |
| | | CRYSTAL | | | |
| X401 | H0100431 | HC-18/U 19.7475 MHz | R461,472 0500 | J00245473 | " " " " 47 kΩ |
| | | | R405,465,466 | J00245104 | " " " " 100 kΩ |
| | | | R493 | J00245154 | " " " " 150 kΩ |
| | | | R448,452,487, 0503, 0505 | J00245184 | " " " " 180 kΩ |
| | | CRYSTAL FILTER | | | |
| XF401 | H1100860 | XF8.9HS | | | |
| XF402(Option) | H1100880 | XF8.9HC | | J00245334 | " " " " 330 kΩ |

| | | | | | | | | |
|---------------------------|-----------|---|--------------|------------------------------------|-----------------------|------------------|--|--------------------------------|
| C906 | K41140338 | Electrolytic 25WV | 3300 μ F | | | CAPACITOR | | |
| | | | | C1017 | K13170473 | Ceramic | 50WV | 0.047 μ F |
| | | | | C1016 | K12279003 | " | 500WV | 0.0022 μ F |
| | | | | C1005, 1006, 1013-1015, 1018 | K12279004 | " | " | 0.0047 μ F |
| | | RELAY | | | | | | |
| RL901 | M1190003 | FRL-264 D012/04CS-01 | | C1010 | K12279002 | " | " | 0.01 μ F |
| | | | | C1009 | K40240106 | Electrolytic | 250WV | 10 μ F |
| | Q5000011 | Wrapping terminal C | | C1011 | K40240336 | " | " | 33 μ F |
| | Q5000004 | Test point D | | C1012 | K40240476 | " | " | 47 μ F |
| | | | | C1001-1004 | K40270106 | " | 450WV | 10 μ F |
| | | | | C1007, 1008 | K40260226 | " | 350WV | 22 μ F |
| | | | | | | | | |
| RECT. B UNIT | | | | | | | | |
| Symbol No. | Parts No. | Description | | | | | | |
| | C0019680 | RECT. B unit with components | | | | Q5000011 | Wrapping terminal C | |
| PB-1968B | F0001968B | P.C. Board | | | | | | |
| | | | | | | | | |
| | | TRANSISTOR | | | | | | |
| Q1003 | G3106390 | 2SA639 | | | CAPACITOR UNIT | | | |
| Q1001 | G3107330 | 2SA733 | | | Symbol No. | Parts No. | Description | |
| Q1002 | G3303720Y | 2SC372Y | | | | C0019690 | CAPACITOR unit with components. | |
| | | | | | PB-1969A | F0001969A | P.C. Board | |
| | | | | | | | | |
| | | DIODE | | | | | RESISTOR | |
| D1004, 1005, 1008-1011 | G2015550 | Si | 1S1555 | | R1101, 1102 | J10276474 | Carbon composition 1/2W GK 470k Ω | |
| D1002, 1003, 1012 | G2090002 | " | 10D10 | | | | | |
| D1006, 1007 | G2090001 | " | 10D1 | | | | | |
| D1001 | G2090081 | " | SM1-12 | | | | CAPACITOR | |
| | | | | | C1101, 1102 | K43270003 | Electrolytic | 500WV 200 μ F (CE-62LW) |
| | | | | | | | | |
| | | RESISTOR | | | | | | |
| R1021 | J00245681 | Carbon film 1/4W VJ 680 Ω | | | | | | |
| R1011, 1016, 1020 | J00245472 | " | " | " | " | " | " | 4.7 k Ω |
| R1013, 1015 | J00245103 | " | " | " | " | " | " | 10 k Ω |
| R1014 | J00245123 | " | " | " | " | " | " | 12 k Ω |
| R1017-1019 | J00245223 | " | " | " | " | " | " | 22 k Ω |
| R1012 | J00245563 | " | " | " | " | " | " | 56 k Ω |
| R1010 | J20306562 | Metallic film 1W | | 5.6 k Ω | | | | |
| R1022 | J20306390 | " | " | " | " | " | " | 39 Ω |
| R1005 | J20336391 | " | " | 2W | " | " | " | 390 Ω |
| R1006 | J20336471 | " | " | " | " | " | " | 470 Ω |
| R1008 | J20336222 | " | " | " | " | " | " | 2.2 k Ω |
| R1007 | J20336332 | " | " | " | " | " | " | 3.3 k Ω |
| R1009 | J20336473 | " | " | " | " | " | " | 47 k Ω |
| R1023 | J10276474 | Carbon composition 1/2W GK 470 k Ω | | | | | | |
| | | | | | | | | |
| | | | | | | | | |
| | | POTENTIOMETER | | | | | | |
| VR1001 | J50708103 | V18K3-2 | | 10 k Ω B | C1203 | K30176271 | Dipped mica | 50WV 270 pF |
| | | | | | C1208 | K30176391 | " | " |
| | | | | | C1202 | K30176651 | " | " |
| | | | | | C1207 | K30209001 | " | " |
| | | | | | C1201 | K30209003 | " | " |
| | | | | | C1206 | K02173100 | Ceramic | 50WV CH 10 pF |
| | | | | | C1205 | K02179012 | " | " |
| | | | | | C1204 | K02175820 | " | " |
| | | | | | | | | 82 pF |
| | | | | | | | | |

| AMUNIT | | | | CAPACITOR | | |
|---|-----------|-----------------------------|-------------------------------|-----------|--------------------------|-----------|
| Symbol No. | Parts No. | Description | C2420 | K30176331 | Dipped mica 50 WV | 390 pF |
| | C0020400 | AM unit with components | C2416 | K02175390 | Ceramic " CH | 39 pF |
| PB-2040 | F0002040 | P.C. Board | C2417, 2426 | K02175101 | " " " | 100 pF |
| | | | C2418 | K02175151 | " " " | 150 pF |
| | | FET & TRANSISTOR | C2401 | K02175221 | " " " | 220 pF |
| Q2404 | G3800190G | FET 2SK19GR | C2419, 2421- | K13170103 | " " " | 0.01 μF |
| Q2406 | G4800510C | " 3SK51-03 | 2423, 2428, | | | |
| Q2405, 2406, 2407 | G3303800Y | TR 2SC380TM-Y | 2429, 2434, | | | |
| Q2401 | G3307320G | " 2SC732TM-GR | 2436, 2437- | | | |
| Q2402, 2409 | G3318150Y | " 2SC1815Y | 2440, 2445- | | | |
| | | | 2447 2449 | | | |
| | | | C2425, 2427, | K13170473 | " " " | 0.047 μF |
| | | | 2430-2433, | | | |
| | | DIODE | 2436, 2439 | | | |
| D2406 | G2090029 | Ge. 1N60 | C2451 | K50177102 | Mylar " " | 0.001 μF |
| D2401, 2402, 2404, 2405 | G2015550 | Si. 1S1555 | C2407 | K50177222 | " " " | 0.0022 μF |
| | | | C2410, 2415, | K50177103 | " " " | 0.01 μF |
| | | | 2435, 2438, | | | |
| | | CRYSTAL | 2447, 2449 | | | |
| X2401 | H0100423 | HC-18/U 8988.3 kHz | C2402 | K50177473 | " " " | 0.047 μF |
| | | | C2414 | K50177224 | " " " | 0.22 μF |
| | | RESISTOR | C2405, 2450, | K40170105 | Electrolytic " | 1 μF |
| R2441, 2457 | J00245470 | Carbon film ¼W VJ 47 Ω | 2453 | | | |
| R2455 | J00245560 | " " " " 56 Ω | C2452 | K40140475 | " 25 WV | 4.7 μF |
| R2411, 2414, 2418, 2422, 2425, 2432, 2434, 2447 | J00245101 | " " " " 100 Ω | C2406, 2408, 2409, 2424, 2454 | K40126106 | " 16 WV | 10 μF |
| R2406, 2423 | J00245331 | " " " " 330 Ω | C2446 | K40126476 | " " " | 47 μF |
| R2445, 2452 | J00245471 | " " " " 470 Ω | C2403 | K40126107 | " " " | 100 μF |
| R2409, 2419, 2435, 2436, 2438-2440 | J00245102 | " " " " 1 kΩ | C2413 | K40126227 | " " " | 220 μF |
| | | | | | | |
| | | | | | TRIMMER CAPACITOR | |
| | | | TC2402 | K91000012 | ECV 1ZW 10 x 32 | 10 pF |
| R2437 | J01245102 | " " " TJ 1 kΩ | TC2401 | K91000013 | " 20 x 32 | 20 pF |
| R2431 | J00245272 | " " " VJ 2.7 kΩ | | | | |
| R2401, 2410, 2453, 2456 | J00245332 | " " " " 3.3 kΩ | | | INDUCTOR | |
| R2454 | J01245332 | " " " TJ 3.3 kΩ | L2401, 2403 | L1190016 | FL5H-101K | 100 μH |
| R2404 | J00245392 | " " " VJ 3.9 kΩ | L2402 | L1190017 | FL5H-102K | 1 mH |
| R2420, 2429 | J00245472 | " " " " 4.7 kΩ | | | TRANSFORMER | |
| R2442, 2444 | J00245562 | " " " " 5.6 kΩ | T2401 | L0020141 | R12-4171 | |
| R2402, 2424, 2446, 2449, 2458 | J00245103 | " " " " 10 kΩ | | | | |
| | | | | | CONNECTOR | |
| R2407 | J00245123 | " " " " 12 kΩ | J2401, 2404 | P1090016 | SQ3056 | |
| R2405, 2433 | J00245153 | " " " " 15 kΩ | J2402 | P0090041 | 5048-03A | |
| R2430 | J00245183 | " " " " 18 kΩ | J2403 | P0090037 | 5048-08A | |
| R2443, 2450 | J00245223 | " " " " 22 kΩ | P2401 | P0090075 | P-7015 | |
| R2403 | J00245273 | " " " " 27 kΩ | | | | |
| R2408, 2412, 2421 | J00245333 | " " " " 33 kΩ | | Q5000011 | Wrapping terminal C | |
| R2416 | J00245393 | " " " " 39 kΩ | | B4025945B | P.C.B. support D | |
| R2427 | J00245563 | " " " " 56 kΩ | | | | |
| R2428 | J00245683 | " " " " 68 kΩ | | | | |
| R2417, 2426, 2451 | J00245104 | " " " " 100 kΩ | | | | |
| | | | | | | |
| | | THERMISTOR | | | | |
| TH2401 | G9090003 | D33A | | | | |