

Dual

Service Manual Dual 1019



Technical Data:

Current:	alternating, 50 or 60 cycle, with appropriate motor pulleys
Line voltage:	selector for 110, 150, or 220 volts (see schematic P. 4)
Drive:	four-pole, single-phase, induction motor
Power consumption:	6.5 watts approximately
Current requirements:	50 mA maximum at 220 V, 50 cycle; 90 mA maximum at 117 V, 60 cycle
Turntable speeds:	78, 45, $33\frac{1}{3}$ and $16\frac{2}{3}$ r.p.m.
Speed adjustment:	adjustment range of 6% at all four turntable speeds
Turntable:	non-magnetic, $7\frac{1}{2}$ lbs., balanced
Wow and flutter:	$\pm 0,1 \%$
Signal-to-noise:	at 100 c.p.s., better than 50 db
Tonearm:	balanced on all three axes, extremely low mass, and precision, friction-free suspension (vertical and horizontal friction bearing friction less than 0.05 gm)
Pickup cartridge:	tonearm will accept all cartridges with $\frac{1}{2}$ " mounting and weighing from 1—16 gms.
Weight of unit:	$16\frac{1}{4}$ lbs., less packing
Dimensions and mounting cutouts:	see installation instructions

Fig. 1 Tonearm hook-up schematic

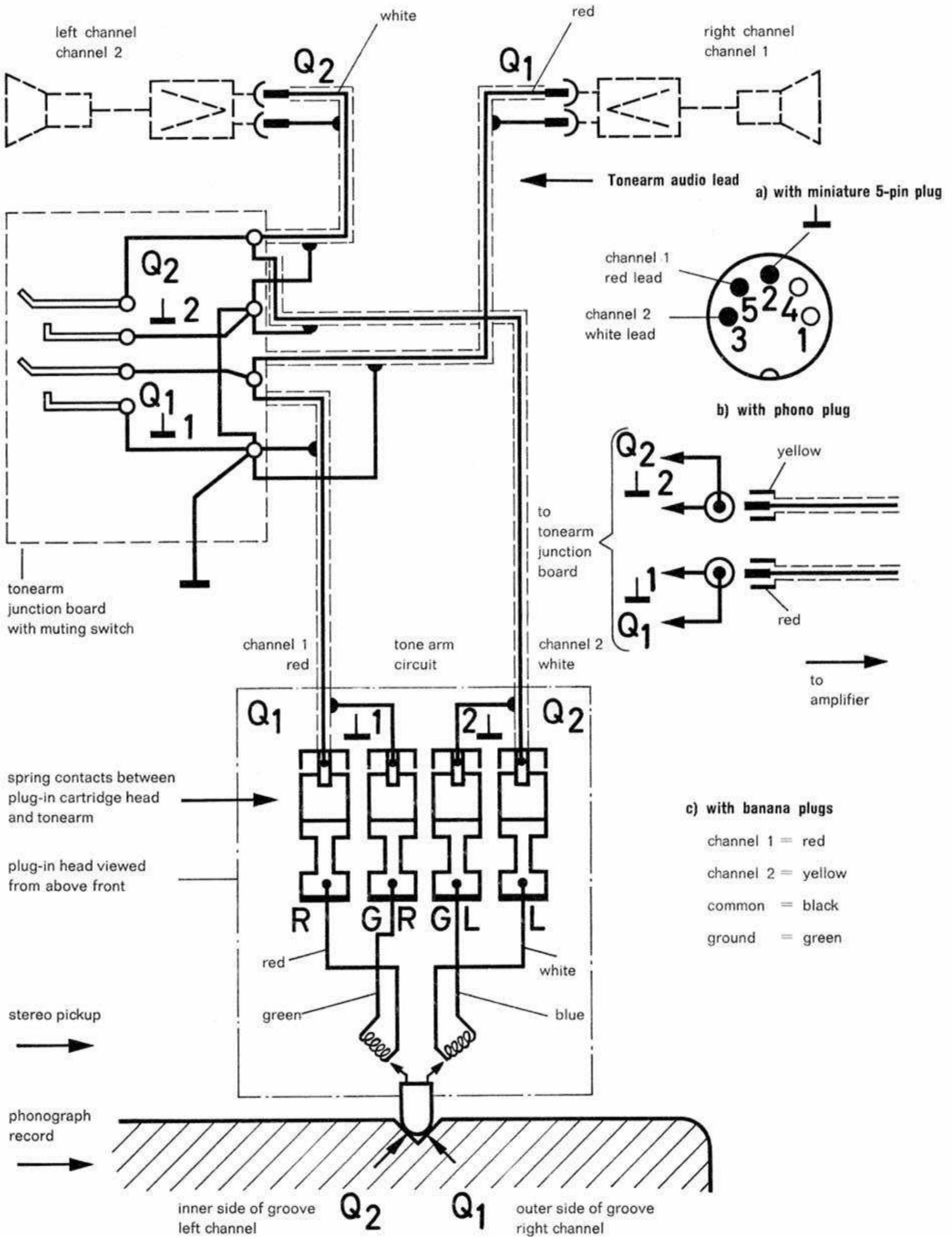

Contents

	Page
Technical data	1
Tonearm hook-up schematic	2
Motor and drive	4
Fine-speed regulation	5
Turntable does not turn when unit plugged in and "Start" switch operated	5
Turntable does not come up to speed	5
Correct speed obtained only by extreme adjustment of fine-speed adjustment	5
Fine-speed adjustment inoperative	5
Tonearm and suspension	6
Tonearm anti-skating mechanism	7
Needle slides out of groove	7
Tonearm sets down beside arm-rest	7
Horizontal friction too great	7
Arm set-down not free	7
Tonearm movements	8
Tonearm set-down and lift	8
Tonearm does not move onto record when drop cycle actuated	9
Tonearm lowers too quickly onto record when drop cycle actuated	9
Tonearm misses edge of record	9
Tonearm strikes record during change cycle	9
Start cycle	10
Manual operation	10
Stop switching	11
Record drop	11
Shut-off	12
Shut-off and change cycle	12
Tonearm returns to arm rest immediately after being manually placed on record	13
Turntable does not run after automatic set-down of tonearm	13
Tonearm returns to its rest after each record	13
Turntable does not turn when switch moved to "Manual" and tonearm off resting post	13
Last record of stack keeps repeating	13
Record drops after switch moved to "stop" another record drops when switch moved to "start"	13
Record drop does not operate	13
Turntable slows down when record drops	13
Acoustic feedback	13
Lubrication	14
Replacement parts and exploded view	15—20

Fig. 2 Motor suspension and turntable drive

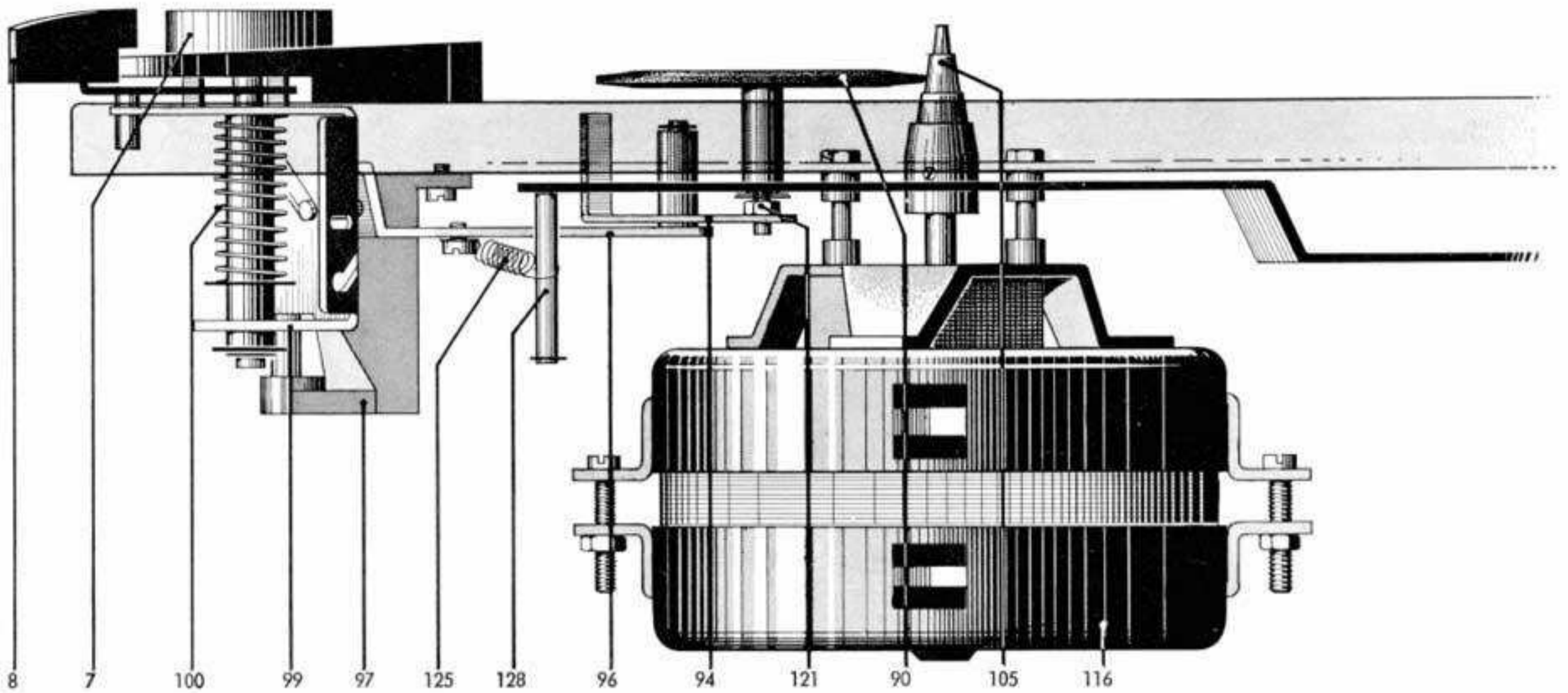

Motor and Drive

The turntable and change cycle are driven by a four-pole induction motor (116) with an extremely low magnetic field and vibration-free drive.

Motor speed is constant for line variations of $\pm 10\%$. Motor speed is dependent on, and proportional to, line frequency.

Adapting for operation at line frequencies of 50 or 60 cycle is accomplished by the use of replaceable motor pulleys (105).

Motor pulley, 50 cycle Part No. 31 N - U 20

Motor pulley, 60 cycle Part No. 31 N - U 28

The motor pulley is secured to the motor shaft by means of a set screw. When changing pulleys, care must be taken

Fig. 3 Motor field connections, voltage selector in 110 volt position

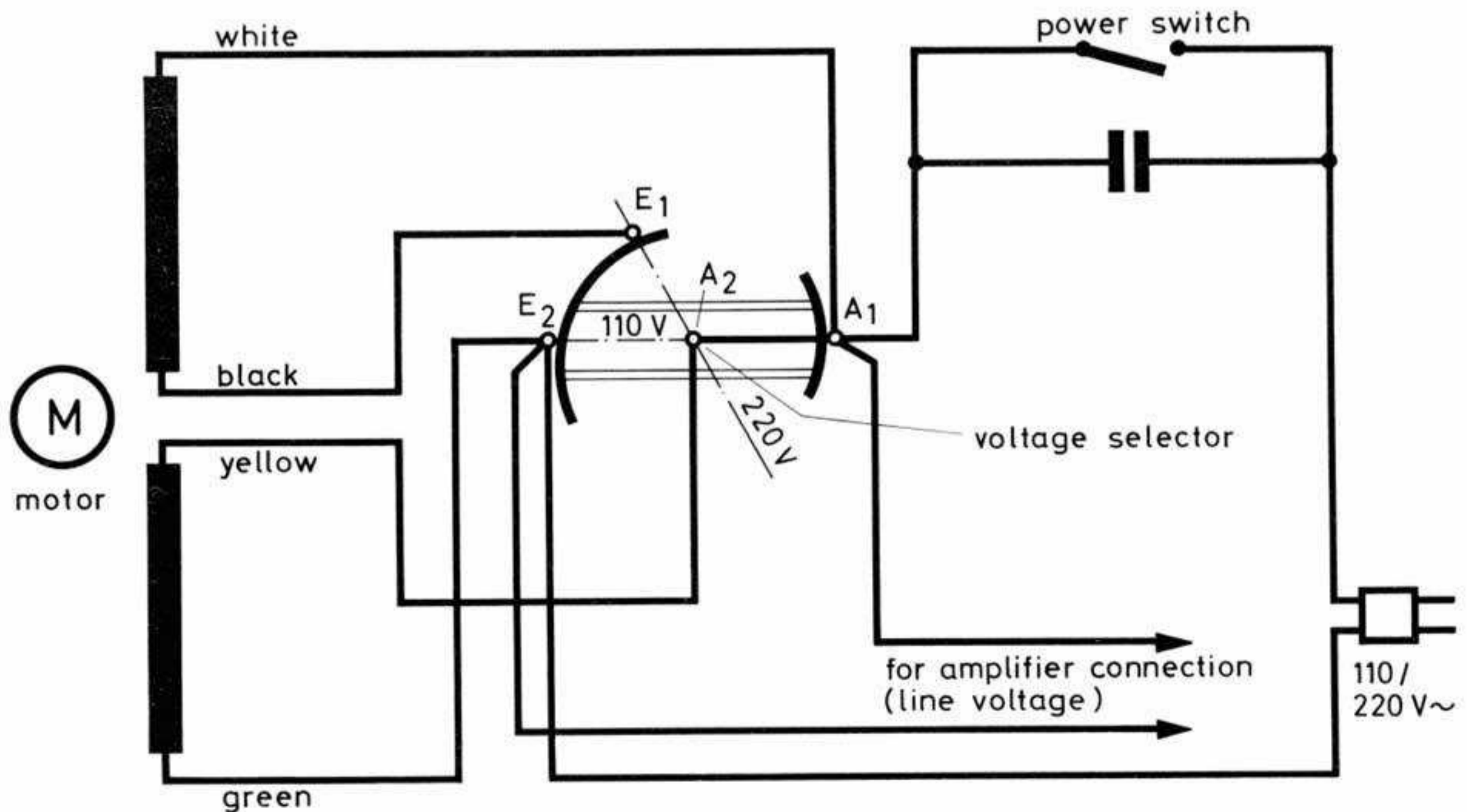

that it is set at the correct height (see Fig. 3 of the troubleshooting chart).

The turntable is driven by means of the idler wheel (90) which, to prevent damage to its friction surfaces, automatically disengages when the tonearm is in the rest position. Setting the turntable speed to $16\frac{2}{3}$, $33\frac{1}{3}$, 45 and 78 r.p.m. is accomplished by raising or lowering the drive wheel to the corresponding step of the motor pulley.

Similarly, moving the speed change knob (8) causes the switch segment (99) to rotate. The grooves in the switch segment guide the rocker assembly (96) on which the drive wheel is mounted. The idler wheel is thus lifted vertically from the motor pulley and placed in the desired position.

Fine-Speed Regulation

A fine speed adjustment for all four record speeds — $16\frac{2}{3}$, $33\frac{1}{3}$, 45 and 78 r.p.m. — permits a variation in turntable speed of 6%.

Turning the control knob (7) causes the switch segment (99) and with it the rocker assembly (96) to move up and down. This vertical motion changes the position of the idler wheel on the selected step of the motor pulley. The tapered shape of the motor pulley gives an adjustment range of $\pm 3\%$ from the nominal speed.

Fig. 4 Turntable speeds and drive wheel shift mechanism

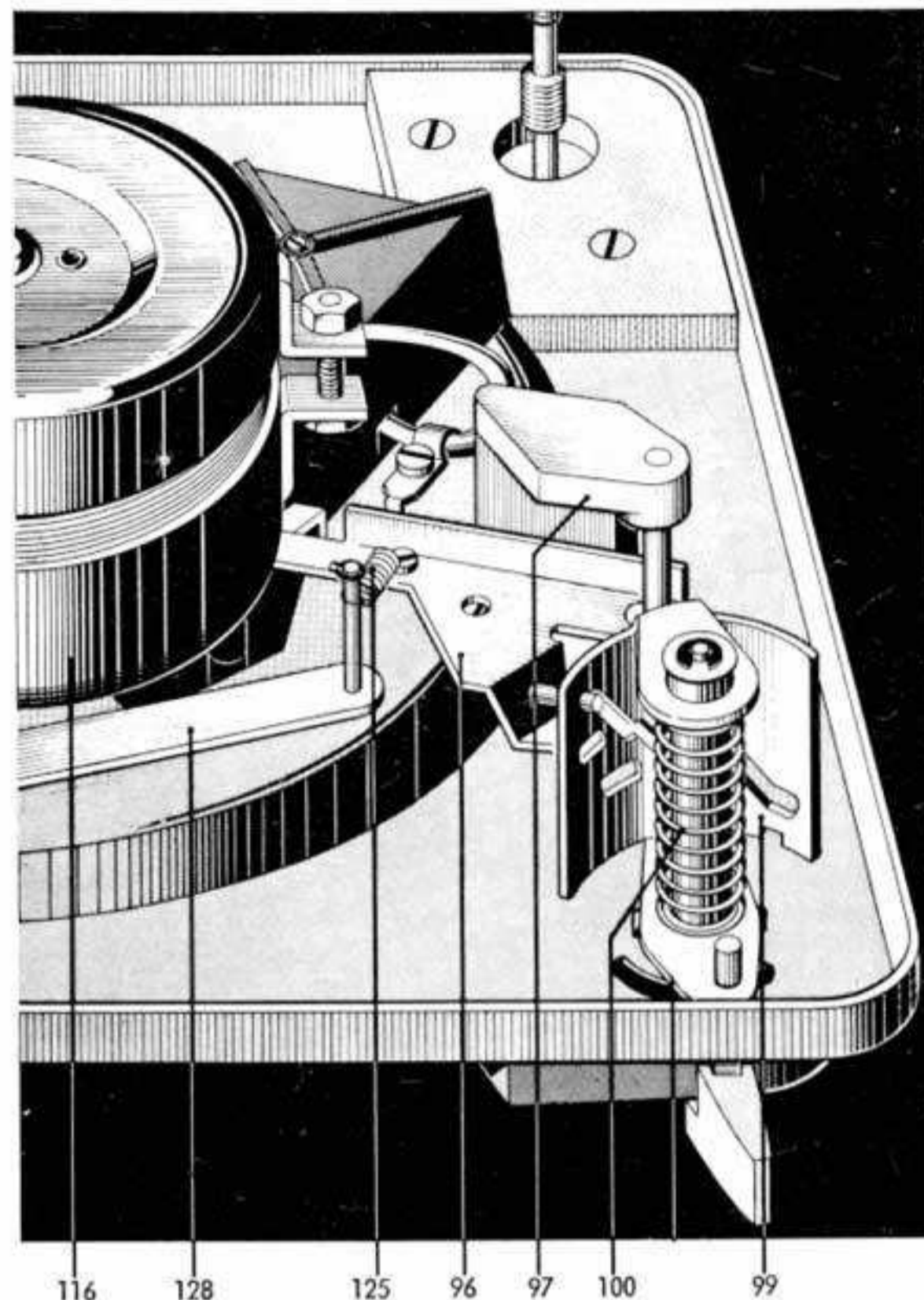

Trouble shooting:

Symptom	Cause	Remedy
Turntable does not run when unit plugged in and "Start" switch operated	a) Current path to motor interrupted	a) Check connection at switch plate and voltage selector
	b) Idler wheel (90) not in contact with turntable	b) Check rocker assembly (96)
	c) Motor pulley (105) loose	c) Tighten motor pulley (105)
Turntable does not come up to speed	a) Motor pulley does not correspond to local line frequency	a) Change motor pulley
	b) Slippage between drive wheel (90) and motor pulley (105)	b) Clean friction surface of idler wheel (90) and motor pulley. Change drive wheel, if necessary
	c) Motor bearing friction	c) Clean motor bearings and re-lubricate from lubrication chart
Correct speed obtained only by extreme adjustment of fine-speed regulator	Idler wheel does not contact motor pulley correctly	Correct idler wheel position. Loosen lock nut (121) and rotate idler wheel shaft (92) The correct position of the idler wheel is in the center of the selector motor pulley step (speed regulator (7) in mid-position) Re-secure lock nut after adjusting
Fine-speed regulator inoperative	Control knob shaft (7) pushed down as a result of shipment	Replace control knob (7)

Fig. 5 Tonearm bearing assembly

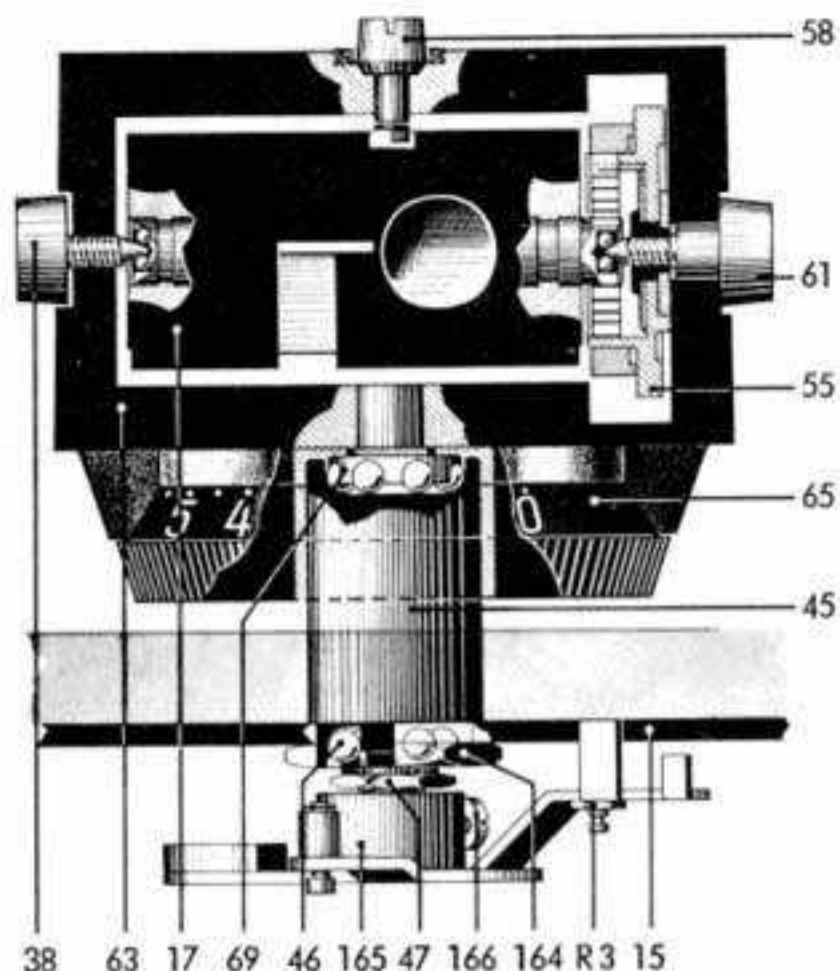

Fig. 6 Tonearm suspension with anti-skating compensation

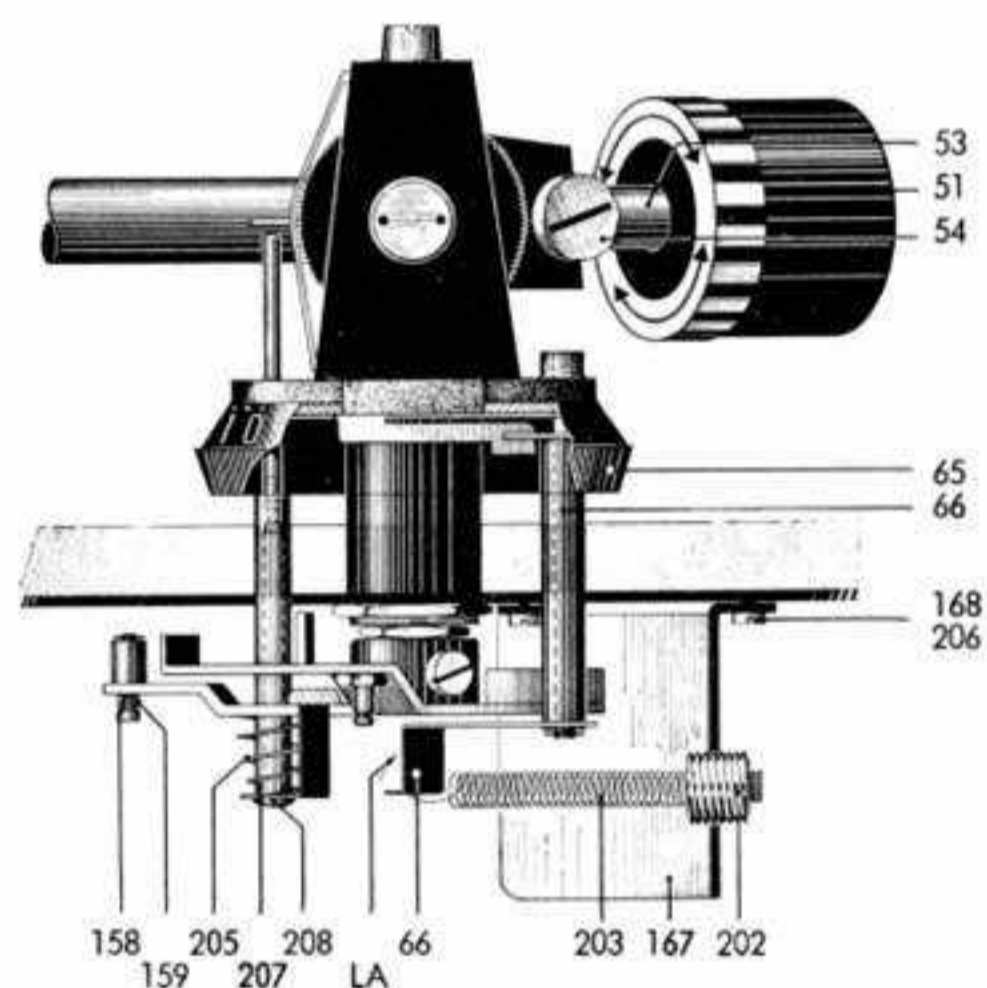
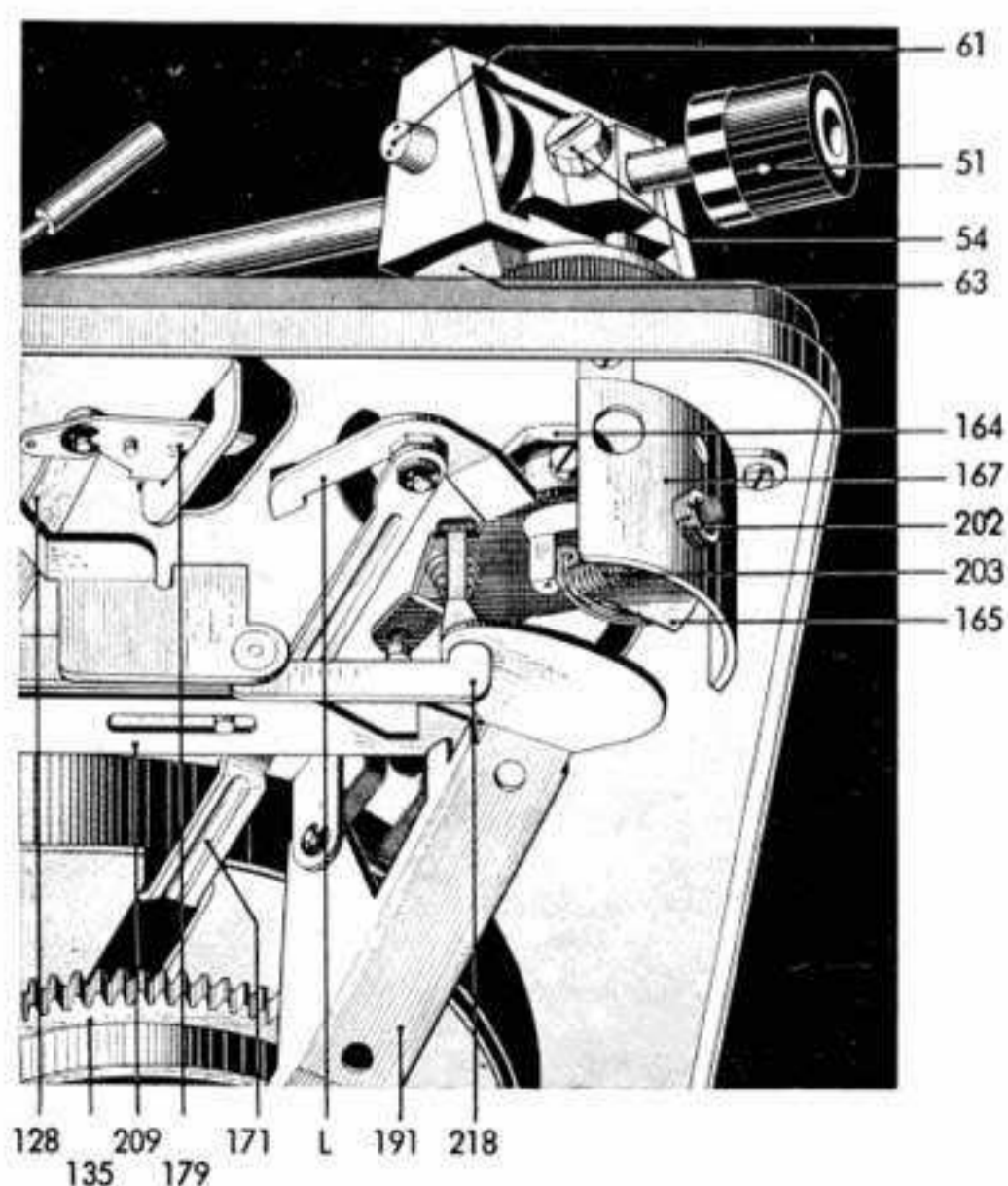

Fig. 7 Tonearm suspension (underneath view)



Tonearm and its suspension

The tubular metal tonearm of the Dual 1019 employs precision ball bearings for both horizontal and vertical movements.

Vertical bearing friction is less than 0.05 gm.

Horizontal bearing friction is less than 0.05 gm.

Especially favorable conditions for pickup are thus provided.

Before setting the tracking pressure corresponding to the cartridge used, set the scale to zero and balance the arm. A rough balance is obtained by sliding the counterweight and spindle. The final setting is made by rotating the counterbalance weight (51).

The counterbalance weight is such that cartridges weighing from 1 to 16 gms. can be balanced.

In order to absorb shocks (sharp blows), the counterbalance weight is mounted on the threaded spindle (53) by means of an elastic coupling. Nylon braking prevents the counterbalance from turning during ordinary handling.

The cartridge head will accept all cartridges with the international $\frac{1}{2}$ " standard mount. Tracking force is set by turning the spring housing (55) with its scale divisions and thus tightening or loosening the internal spiral spring. Adjustment range is continuously variable from 0—5 gms. with scale markings in $\frac{1}{2}$ gram steps.

To replace the tonearm assembly and suspension, the following procedures are recommended:

1. Set tracking force scale to "0"
2. Unsolder the tonearm lead
3. Remove main lever (191) and connecting lever (218)
4. Remove "C" ring and washer of the shut-off slide from the arm segment (165)
5. Unhook tension spring (203) and loosen screws (162, 166)
6. Place adjusting ring (65) of the "Anti-Skating" mechanism in the "5.5" position
7. Lift off arm segment (165) and remove lift screw

To loosen the nut (164), hold the bearing housing (45), between the base plate (15) and adjusting ring (65), with a suitable tool (such as flat pliers). Carefully take out the tonearm, taking care not to bend the spring lever (166).

To re-install the tonearm, the reverse procedure is followed. Before tightening screws (162, 166), check the tonearm position over the arm rest, so that the tonearm lowers onto the rest without binding.

When installed, moving the tonearm in and out with the adjusting ring (65) in its "0" position, should not cause the tension spring (203) to move. If necessary, the setting can be corrected by means of the tabs (LA) of the spring lever (66).

Similarly, after re-installing the retaining spring for the tonearm leads, care must be taken that the arm segment (165) is not impeded by the tonearm leads.

Tonearm Anti-Skating Mechanism

The tendency of a tonearm to slide across the record is caused by the tonearm geometry. In the Dual 1019, this is virtually eliminated by a precision anti-skating mechanism.

Skating force is a function of tonearm geometry, tracking force, and needle contour. The resulting skating effect pulls the tonearm towards the center of the record. This occurs not only on the eccentric shut-off grooves but also causes unequal contact with the groove sides.

Rotating the adjustment ring of the anti-skating mechanism moves the spring lever (66) by means of the curved track inside the adjustment ring, and the tension spring (203) transmits the counter-movement to the tonearm.

The optimum adjustment of the anti-skating mechanism is obtained with a needle curvature of 0.7 ± 0.1 mil. The adjusting screw (threaded bushing) is sealed with glyptol after setting. The Dual Skate-O-Meter and standard record L 096 are required for readjustment, which should only be performed by an authorized service station. Separate Skate-O-Meter instructions available.

Fig. 8 Skating and anti-skating force (underneath view)

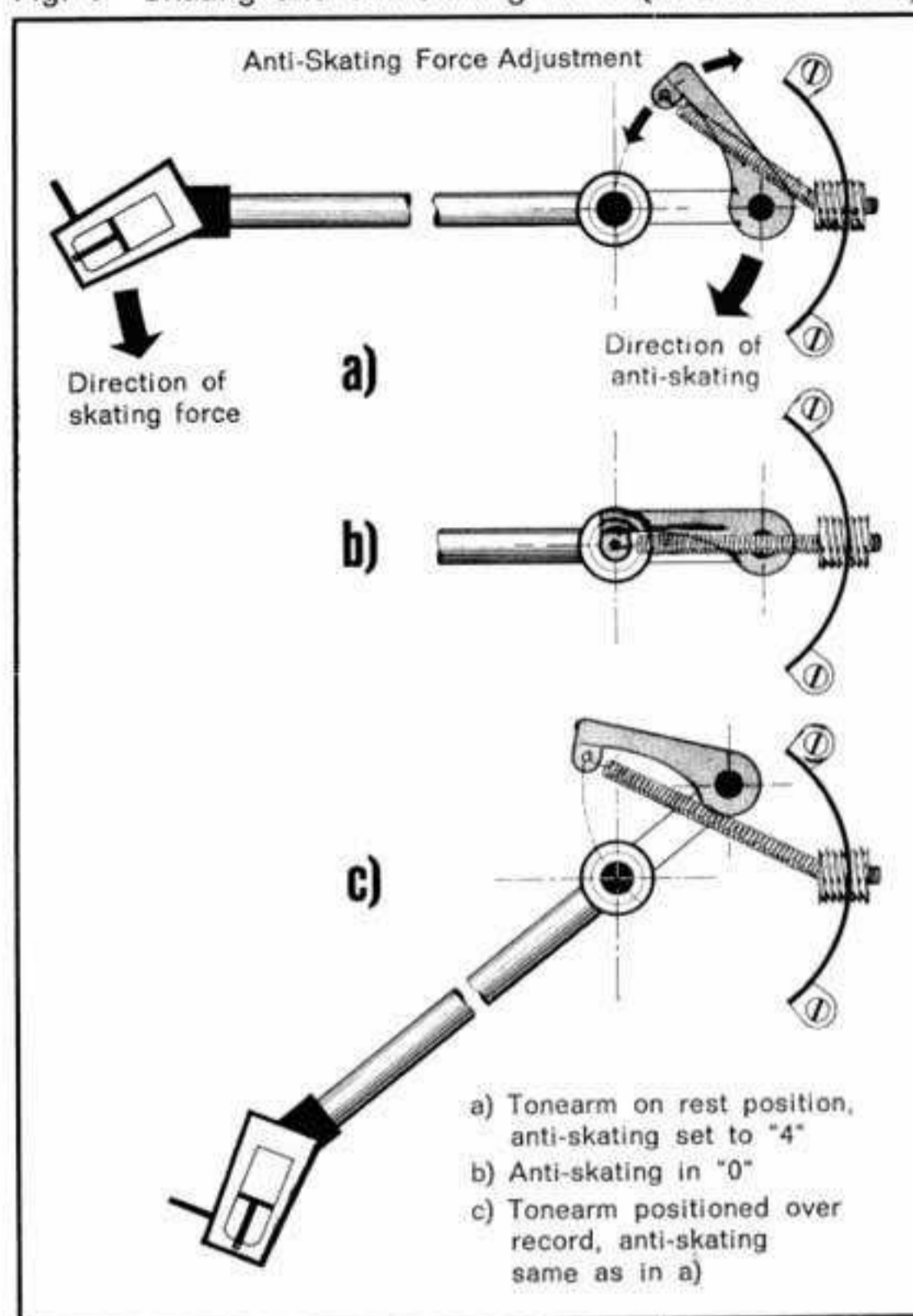

Trouble shooting:

Symptom	Cause	Remedy
Tonearm bearing assembly		
Both bearings require a small, barely noticeable, amount of play. Only the left bearing screw (38) is to be used for adjustment of the horizontal bearings. The vertical bearing adjustment is made by means of the locknut (47).		
Needle slides out of record groove	<ul style="list-style-type: none"> a) Tonearm not balanced b) Tonearm tracking force too light c) Needle defective d) Tonearm bearing friction too high e) Ball missing from shutoff rail (171) 	<ul style="list-style-type: none"> a) See operating instructions b) Adjust with spring housing (barrel screw 55) to correct pressure for particular cartridge c) Replace needle d) Check tonearm bearing e) Install ball (23 or 173)
Tonearm lowers beside tonearm rest (75)	<ul style="list-style-type: none"> a) Arm segment assembly (165) out of position b) The latch (179) presses against the tabs (L) of the arm segment during the change cycle 	<ul style="list-style-type: none"> a) Loosen the machine screws (162, 166) and rotate the arm segment assembly. Then tighten screw (166) and re-check adjustment. Adjustment is correct when tonearm lowers onto arm rest (75) without binding. Finally, tighten screw (162). b) Loosen screw (175). Turn the short arm on the long switch arm piece to correct switch arm position. Turn the main cam by hand, and adjust so that when the tonearm lowers onto the arm rest, clearance of about $\frac{1}{64}$" is obtained between latch segment tabs.
Horizontal bearing friction too high	Tonearm is set too high on the arm lift. Main lever jams against the guide pin of the lift screw assembly	Pickup needle should not be farther from the record than $\frac{1}{4}$ ". Adjust by turning screw (R 8, Fig. 12).
Vertical movement of tonearm is impeded during set down cycle	<ul style="list-style-type: none"> a) Bearing friction too high b) Lift screw jams in guide sleeve of the arm segment (165) 	<ul style="list-style-type: none"> a) Check bearing screw (38) and arm balance b) Remove and clean lift screw

Fig. 9 Tonearm guide mechanism

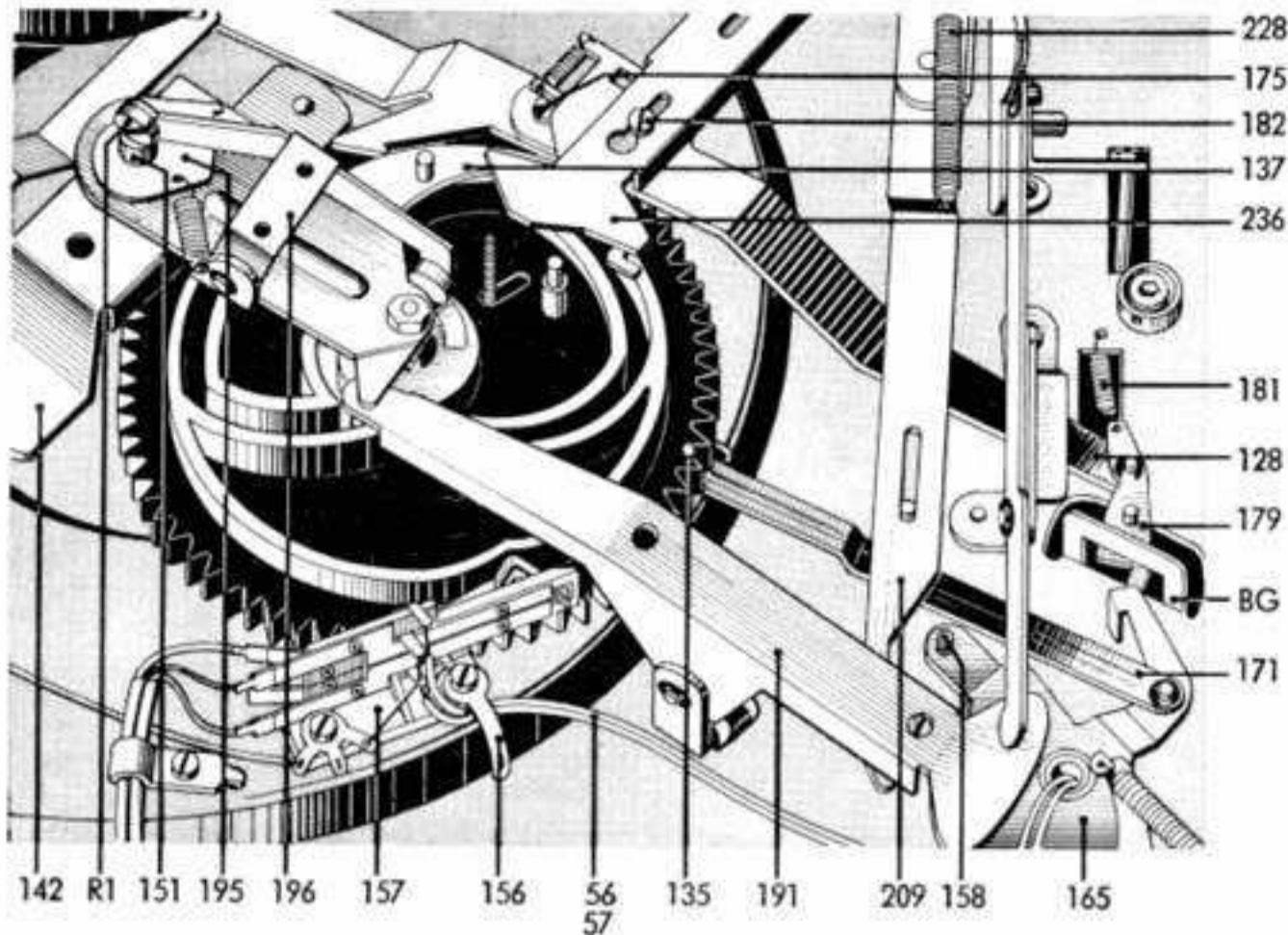

Tonearm raising and lowering, as well as horizontal movements, are controlled by main lever (191) and lift screw (207).

Setting the unit for playback of 7", 10", and 12" records is accomplished by means of the indexing switch (82a, Fig. 12). The set-down points of the tonearm are determined by the eccentric of the arm positioning slide (209) contacting the record size selector lever (230, Fig. 13).

Horizontal movement of the tonearm is limited by the arm segment (165) striking the arm positioning slide (209). During the change cycle, the main lever (191) raises the arm positioning slide, bringing it within reach of the spring stud (158). On completion of the change cycle (i. e., set-down of the tonearm on the record), the arm positioning slide is again released and returns to its normal position.

It thus moves out of reach of the spring stud (158) permitting the tonearm to move horizontally without hindrance, while playing a record.

Tonearm movements

A guide groove located on the underside of the main cam (135) controls automatic lift-off and set-down of the tonearm as the main cam rotates 360°.

Tonearm lift

The tonearm lift permits the tonearm to be safely set down at any desired position of the record (except in the shut-off area).

Pushing the lift handle towards the front, turns the drive washer (226). This, in turn, moves the connecting lever (218), main lever (191), and lift screw (207) to raise the tonearm.

After the tonearm is moved to the desired spot of the record, the lift handle is lightly tapped towards the rear, to release. Thus freed, connecting lever and the leaf spring (192) of the main lever (191) resume their normal positions and the tonearm lowers. The lowering of the tonearm is delayed by silicone grease on the drive washer.

Fig. 10 Tonearm lift (tonearm raised)

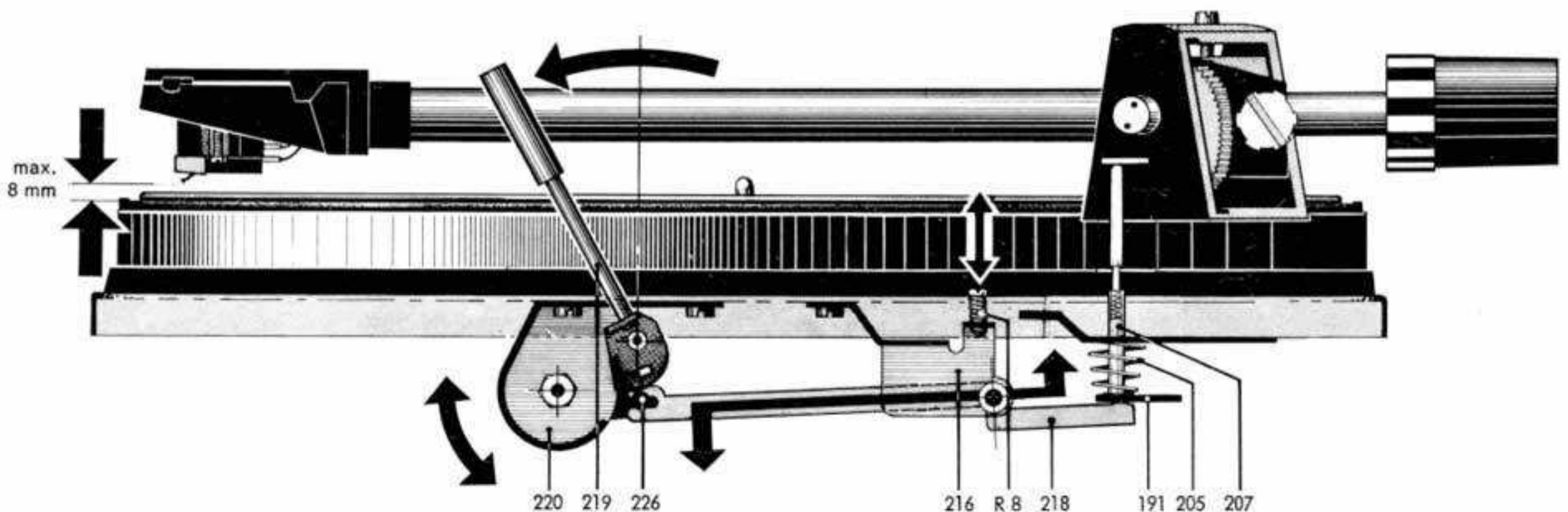
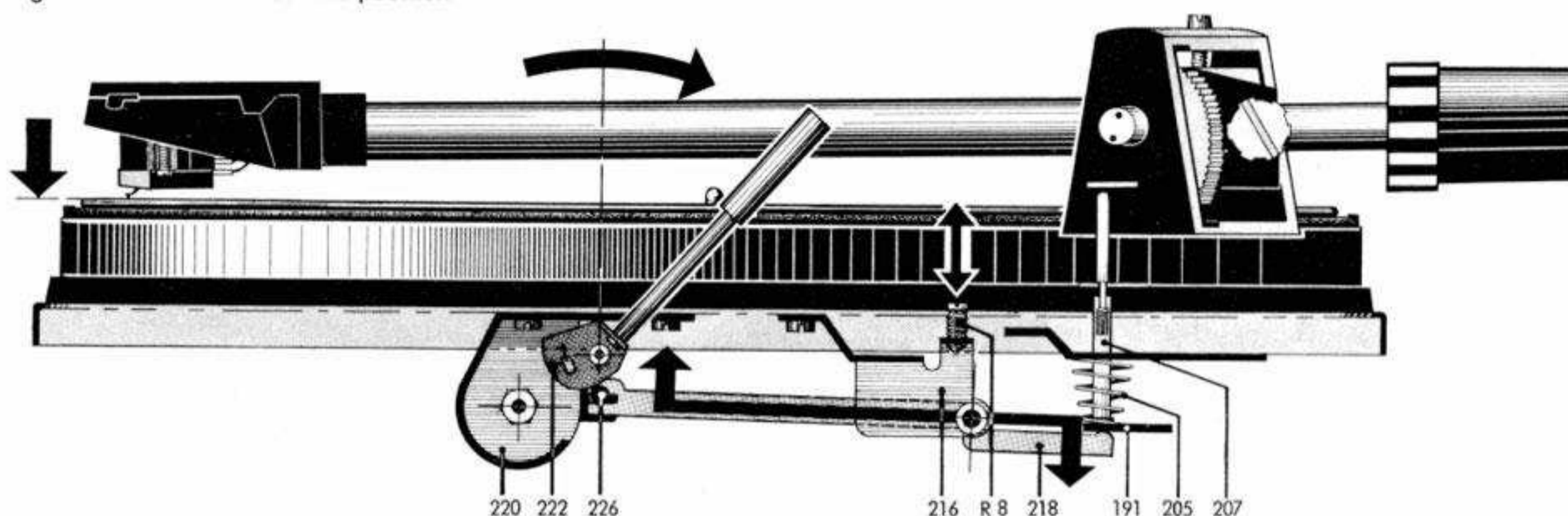

Fig. 11 Tonearm lift in rest position



The set screw (R 8) permits needle height to be varied from 0 to $\frac{1}{4}$ " above the record. Turning to the right increases, to the left decreases, this distance.

Trouble shooting:

Symptom	Cause	Remedy
Tonearm does not move onto record when drop cycle actuated	Damping too great. Drive washer dirty	Loosen nut (224). Remove cover washer (225) and drive washer (226). Clean thoroughly. Spread silicone grease evenly on both sides of the drive washer. Reassemble and wipe off excess grease.
Tonearm lowers too quickly onto record when drop cycle is actuated	Too little damping	Loosen nut (224). Remove cover washer (225) and drive washer (226). Clean thoroughly. Spread silicone grease evenly on both sides of the drive washer. Reassemble and wipe off excess grease.
Tonearm misses edge of record	a) Wrong record size selected b) Set-down incorrectly adjusted c) Record not of standard size d) Tonearm clutch surfaces contaminated	a) Select correct record size with record indexing switch. b) Adjust for 7" record by turning eccentric screw R 5, so that tonearm sets down about $\frac{1}{16}$ " from edge of record. (Adjustment is made only for 7" records; 10" and 12" adjustment being then automatically correct. c) Use standard records. d) Clean clutch surfaces
Tonearm strikes record during change cycle	Tonearm height incorrectly set	Adjust arm height with height adjust screw (58). When correctly adjusted, the pickup needle is $\frac{1}{64}$ " above the dress-up plate (81) when removed from the arm rest.

Fig. 12 Operating elements

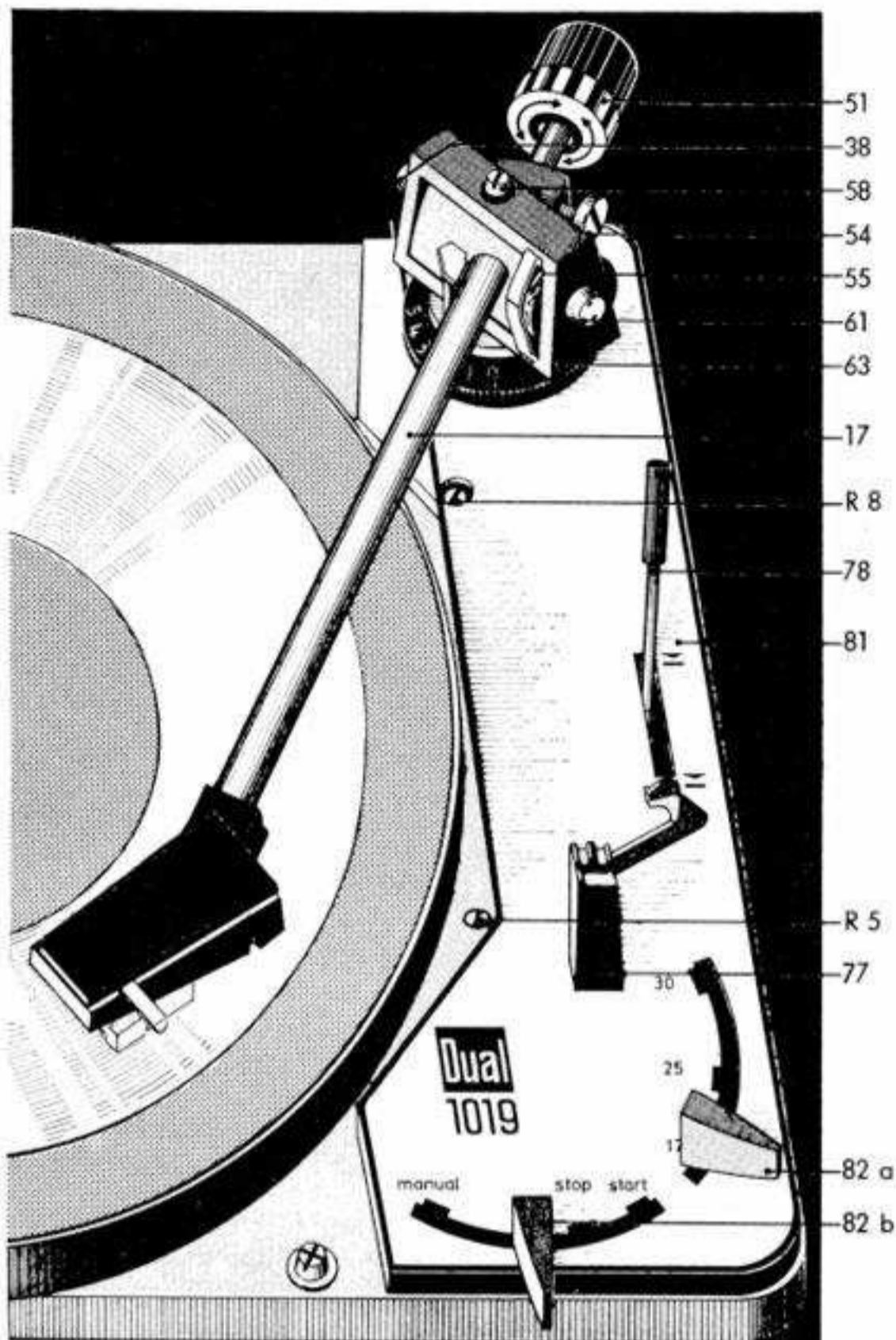

Start cycle

Moving the operating switch (82b, Fig. 12) to "start" moves the switch lever (233) towards the main cam, initiating the following sequence:

- a) The set screw (184) of the switch lever assembly turns the switch arm (128) mounted on the grooved shaft (182). The rocker assembly (96, Fig. 2) moves the drive wheel (90, Fig. 2) into contact with the motor pulley and turntable, by means of a tension spring. At the same time, the switch slide (118, Fig. 15) actuates the line switch through the switch arm, and the turntable begins to turn.
- b) The switch angle (UW) mounted on the switch lever assembly (233) is brought within range of the cam follower lever (137) so that it is pushed into the change position after the rotation of the main cam (Fig. 14).

Moving the operating switch also releases the start lever (236) pulling it towards the main cam by means of the tension spring (234). This causes the coiled spring (177, Fig. 15) to bring the shut-off lever (131, Fig. 18) within range of the main cam dog. Thus the shut-off lever drives the main cam. To prevent mis-operation, the operating switch is locked during the start cycle (i. e. when the main cam is turning). Just before the main cam reaches its null position (at the end of the change cycle), the start lever is pushed clear of the main cam by means of the start pin (SB) of the main cam. This, in turn, restores the switch lever and operating switch to their original positions.

After installing and also after moving the record changer, the unit should be started with the tonearm locked. This will automatically re-adjust the shut-off lever which may have shifted out of position.

Fig. 13 Start position

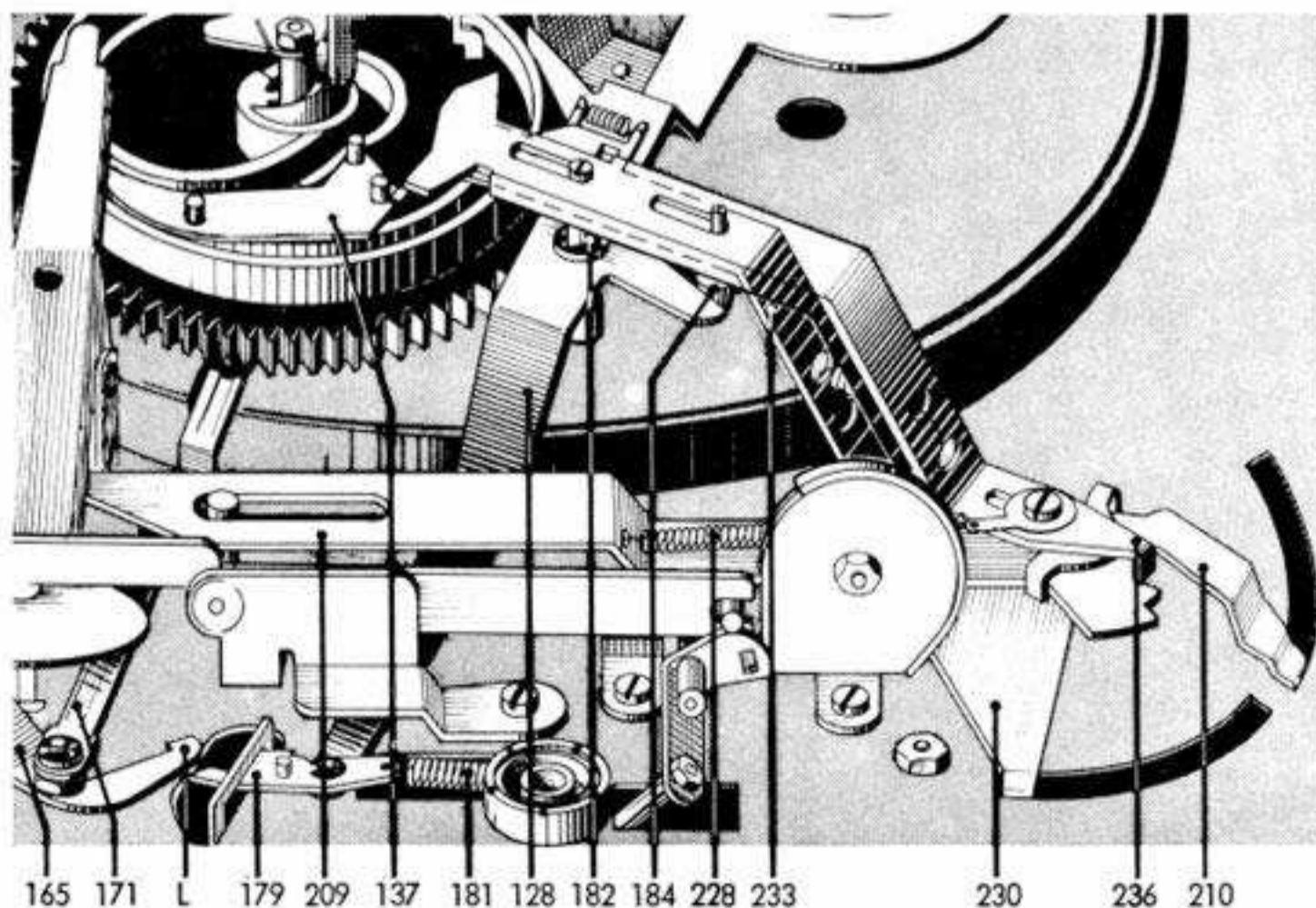

Manual operation

Placing the operating switch in „Manual“ position initiates the start cycle. The switch lever assembly (233) is pushed towards the main cam and the following sequence is set up:

- a) Set screw (184) mounted on the switch lever (233) rotates the switch arm (128) which is mounted on the grooved shaft (182).
- b) The rocker assembly (96, Fig. 2) then moves the idler wheel (90, Fig. 2) into contact with the motor pulley and turntable by means of a tension spring.

c) At the same time, the switch slide (118, Fig. 15) actuates the line switch and the turntable begins to rotate.

d) The switch arm latch (179) rests in the support (BG, Fig. 14) in the base plate, locking the switch arm in position to keep the idler wheel in contact with the turntable.

On reaching the shut-off groove, the tonearm automatically returns to its rest position and the unit shuts off (see shut-off mechanism). However, should the tonearm be lifted off manually and returned to the tonearm rest, the tabs of the arm segment (165) release the latch (179). The tension spring (181) then returns the switch arm (128) to its initial position, opening the line switch and disengaging the idler wheel.

Fig. 14 Stop action

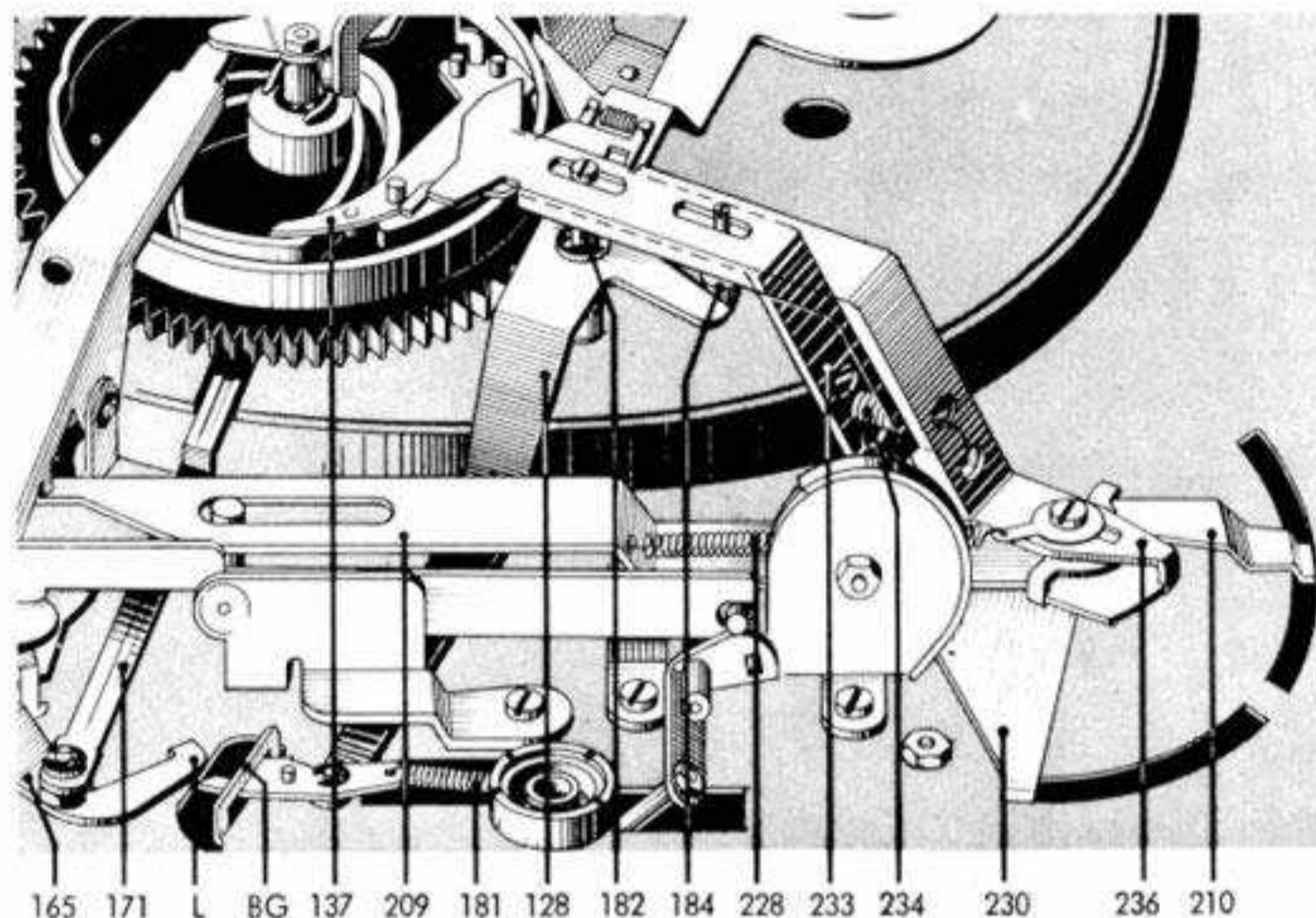
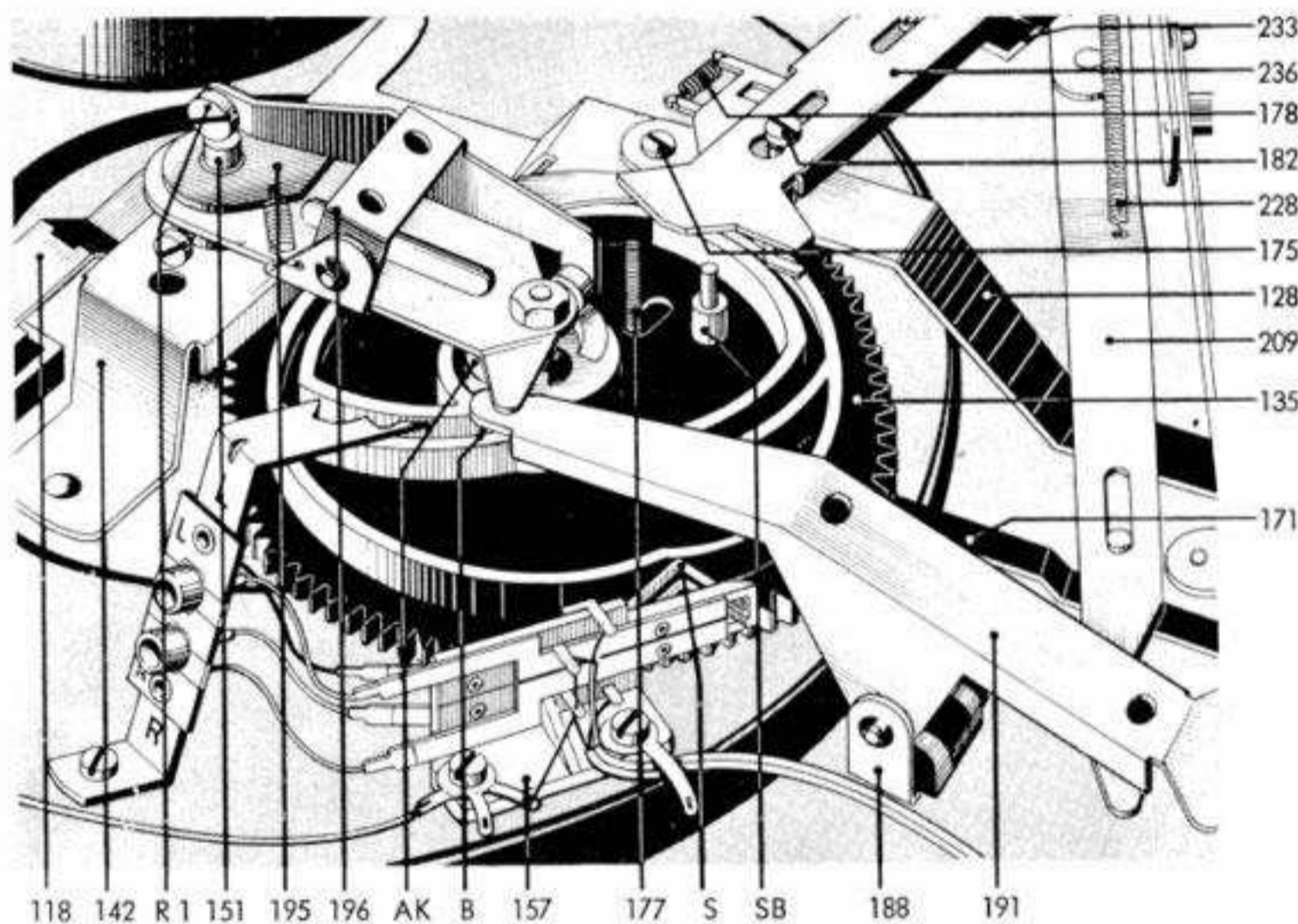

Fig. 15 Record drop



Stop switching

Placing the operating switch in "Stop" position moves the switch lever (233) and switch angle (UW) towards the main cam, as in the start cycle, but only half as far. This causes the main cam to push the cam follower lever (137) to the side, into its stop position.

Record drop

Records to be placed are stacked on the appropriate changer spindle — AW 2 for standard records, AS 9 for 45 r.p.m. records. Records are dropped by the rotation of the main cam (135) whose cam (AK) guides the cam rocker (196), pushing the change actuator stud (151) and releasing a record by means of the automatic spindle.

The design of the main cam is such that a record can only drop when the tonearm is above the tonearm rest — where it cannot interfere with the largest possible record (12" dia.). A muting switch (157) is provided to prevent change cycle noises from being picked up by the tonearm cartridge. The switch springs (S) for both channels are actuated by the main cam (135). In the rest position, the muting switch opens.

Fig. 16 Changing action

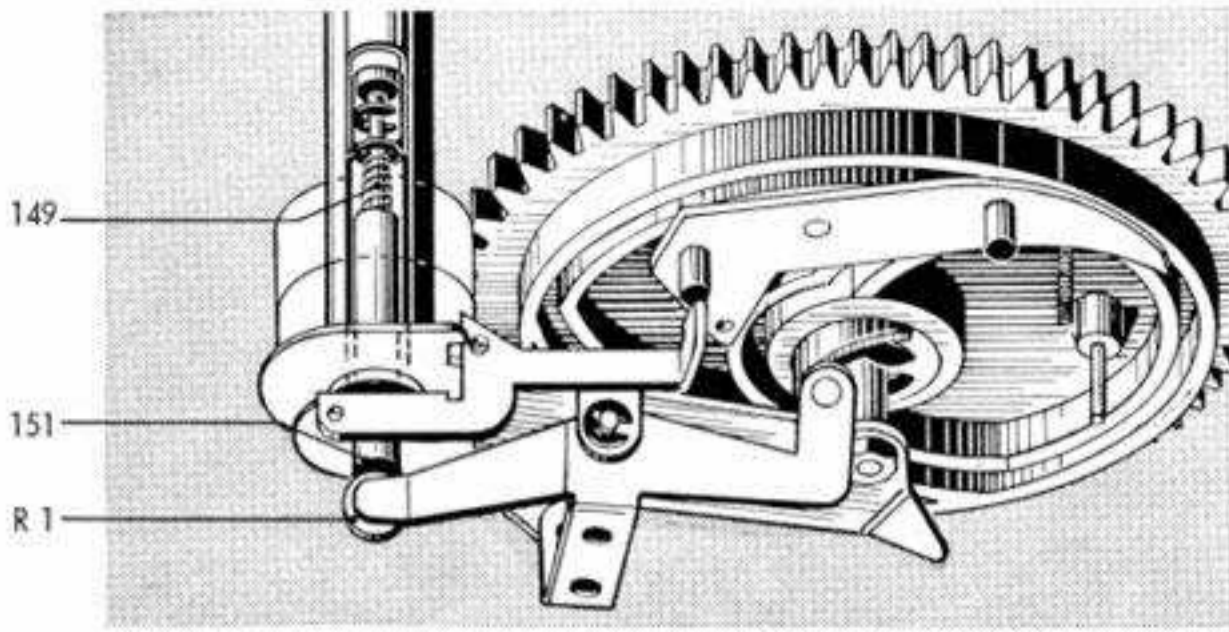

Fig. 17 Shut-off position

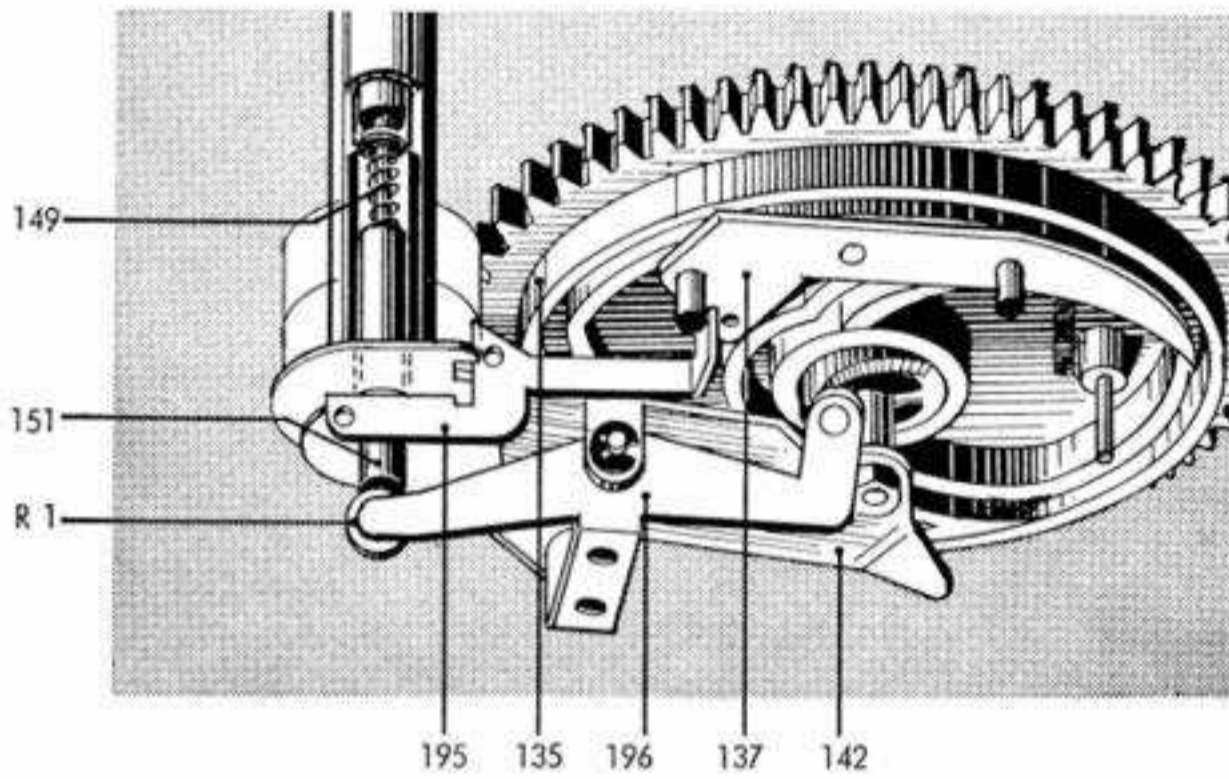
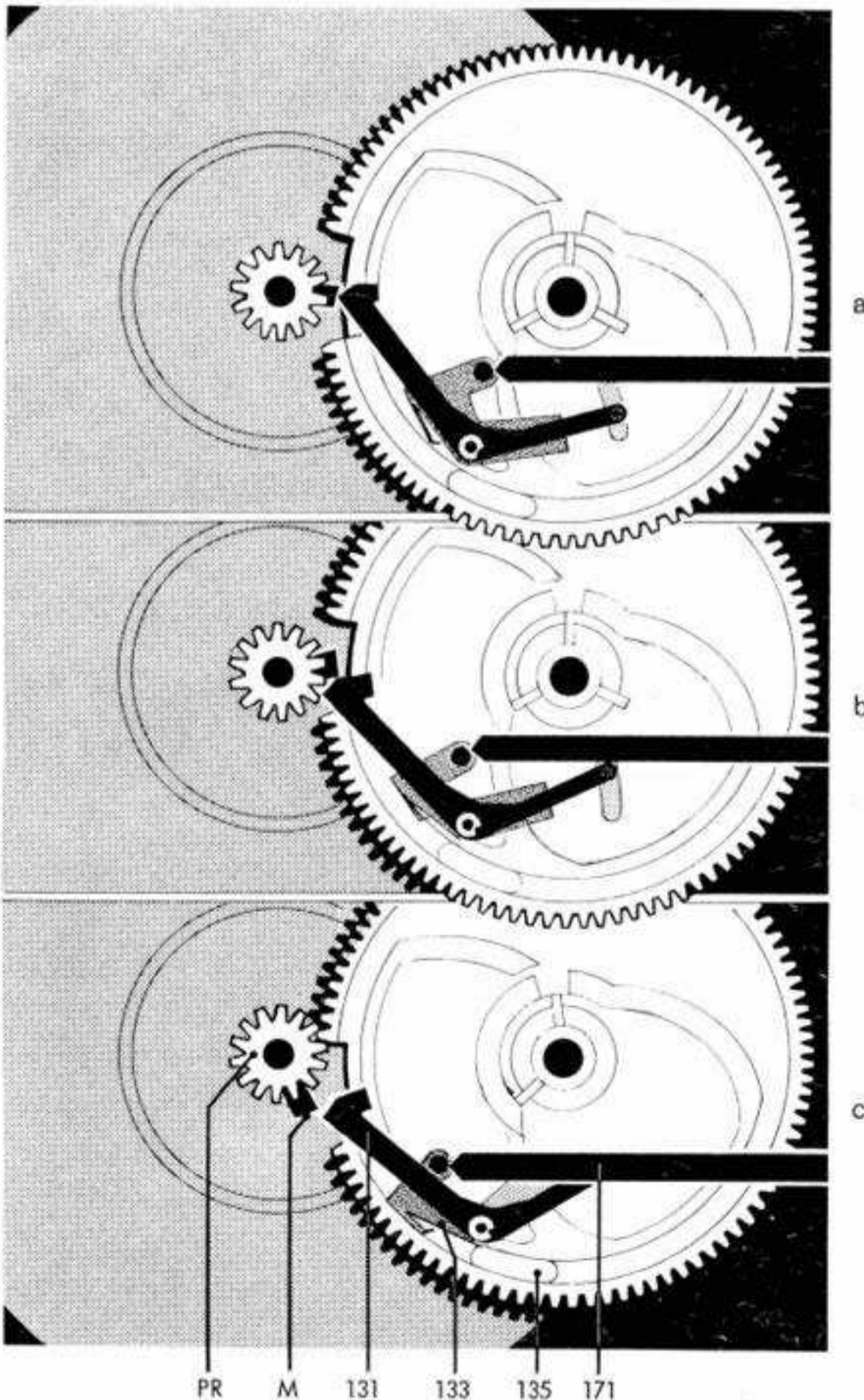

Fig. 18 First stage of change or shut-off action



Shut-off

Shut-off and change functions are determined by the position of the cam follower lever (137, Fig. 17). After the last record of the stack drops, the change lever guides the cam follower lever (137).

To initiate shut-off, the cam follower lever is brought into position (longer end towards the center of the main cam) by the change lever. After the tonearm has swung over the tonearm rest, the guide post (B, fig. 15) of the main lever (191) contacts the outside of the main cam (135) whose vertical profile causes the tonearm to lower onto its support. The traversing of the tonearm releases the latch (179) from its support (BG). However, the main cam keeps the switch arm (128) in its "play" position until the end of the change cycle. When the main cam returns to its null position, the switch arm drops into the cut-out in the main cam, the line switch is operated and the drive wheel is disengaged.

Shut-off and change cycle

The dog (M) on the turntable gear (PR) and the shut-off lever (131) actuate both the change cycle at the end of the record as well as the shut-off after the last record of a stack.

As a record is played, the tonearm moves towards the center of the record, dependent on the pitch of the record groove. This motion carries the shut-off lever towards the dog by means of the shut-off slide (171). The eccentric dog pushes the shut-off lever back at each revolution, as long as the tonearm advance is only one record groove (Fig. 18a). The shut-off groove with its greater pitch brings the shut-off lever against the dog with greater force (Fig. 18b). The shut-off lever then engages and causes the main cam (135) to be driven by the turntable gear out of its null position (Fig. 18c).

Trouble shooting

Symptom	Cause	Remedy
Tonearm returns to arm rest immediately, after being manually placed on record	Shut-off mechanism shifted out of position during shipping	Whenever unit is moved, before using, put unit through start cycle.
Turntable stops after automatic set-down of the tonearm	Switch arm (128) fails to engage latch (179)	Loosen screw (175) and turn the short arm piece on the long switch-arm piece. Turn the main cam to its null position and adjust for about $\frac{1}{64}$ " play between the tabs (L) and the arm segment, when the tonearm drops onto the arm rest.
Tonearm returns to its rest position after each record	Excessive engagement between change lever (195) and cam follower	Re-adjust change lever (195) so that with record on, and spindle locked, there is about $\frac{1}{64}$ " clearance between change lever and the guide post of the cam follower lever (137). With no record loaded, engagement should be about $\frac{1}{32}$ ", to obtain shut-off.
Turntable does not turn when switch moved to "Manual" and tonearm off resting post	Switch lever assembly out of adjustment	Re-adjust with set screw (184) so that in manual position, the latch (179) overtravels the support (BG) about $\frac{1}{64}$ ". Secure adjustment with locknut.
Last record keeps repeating	Inadequate engagement between change lever (195) and cam follower (137)	Re-adjust change lever (195) so that with record on and spindle locked, there is about $\frac{1}{64}$ " clearance between change lever and guide pin of the cam follower lever (137). With no record loaded, engagement should be about $\frac{1}{32}$ ", to obtain shut-off.
Record drops after switch moved to "stop", another record drops when switch moved to "start"	Normal operation	
Records do not drop	<ul style="list-style-type: none"> a) Travel of cam rocker (196), too short b) Automatic spindle not locked in position c) Spindle is defective 	<ul style="list-style-type: none"> a) Re-adjust eccentric R 1 so that when the three supports of the automatic spindle are completely retracted, further rotation of the main cam causes overtravel of about $\frac{1}{64}$" between the cam and the roller of the cam rocker. b) After inserting spindle, rotate to its stop. c) Replace spindle
Turntable slows down as record drops	Travel of cam rocker (196), too long	Re-adjust eccentric R 1 so that when the three supports of the automatic spindle are completely retracted, further rotation of the main cam causes overtravel of about $\frac{1}{64}$ " between cam and roller of the cam rocker.
Acoustic feedback	<ul style="list-style-type: none"> a) Parts of the chassis (e. g. connecting leads) touching the mounting board b) Connecting leads pulled too tight 	<ul style="list-style-type: none"> a) Correct cut-out according to installation instructions. Move leads. b) Loosen or lengthen leads.

Fig. 19 Chassis with turntable removed

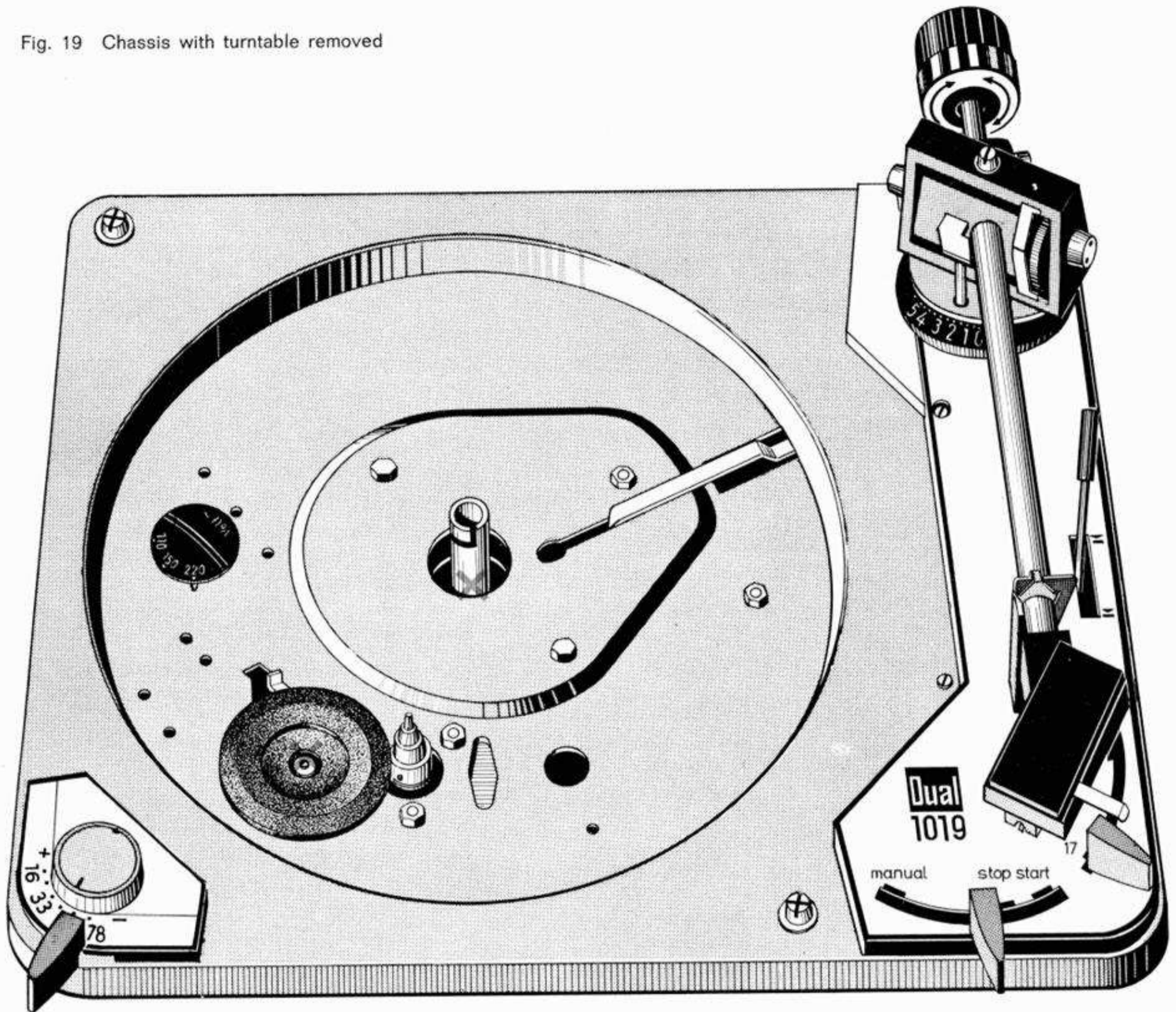

Lubrication

All bearings and sliding points have been properly lubricated during assembly. Re-lubrication is normally not necessary for about two years since all important bearings are provided with oil retainers and sintered bearings.

Lubrication should be applied sparingly. It is of primary importance that no oil or grease should get onto the friction surfaces of the idler wheel, motor pulley or turntable, to avoid slippage. For the same reason, avoid touching these parts.

Use the following lubricants:

- Fine bearing oil, Shell Clavus 17, for motor bearings and sintered bearings.
- Adhesive oil, Renotac, for turntable and drive wheel.
- Molycote paste G, where greater pressure or friction occur.
- Silicone rubber grease, for the drive washer of the tonearm lift.
- Silicone grease.
- Thicker, non-gumming oil, Calypsol WIK 700, for other sliding and bearing points.

Fig. 20 Chassis, viewed from below

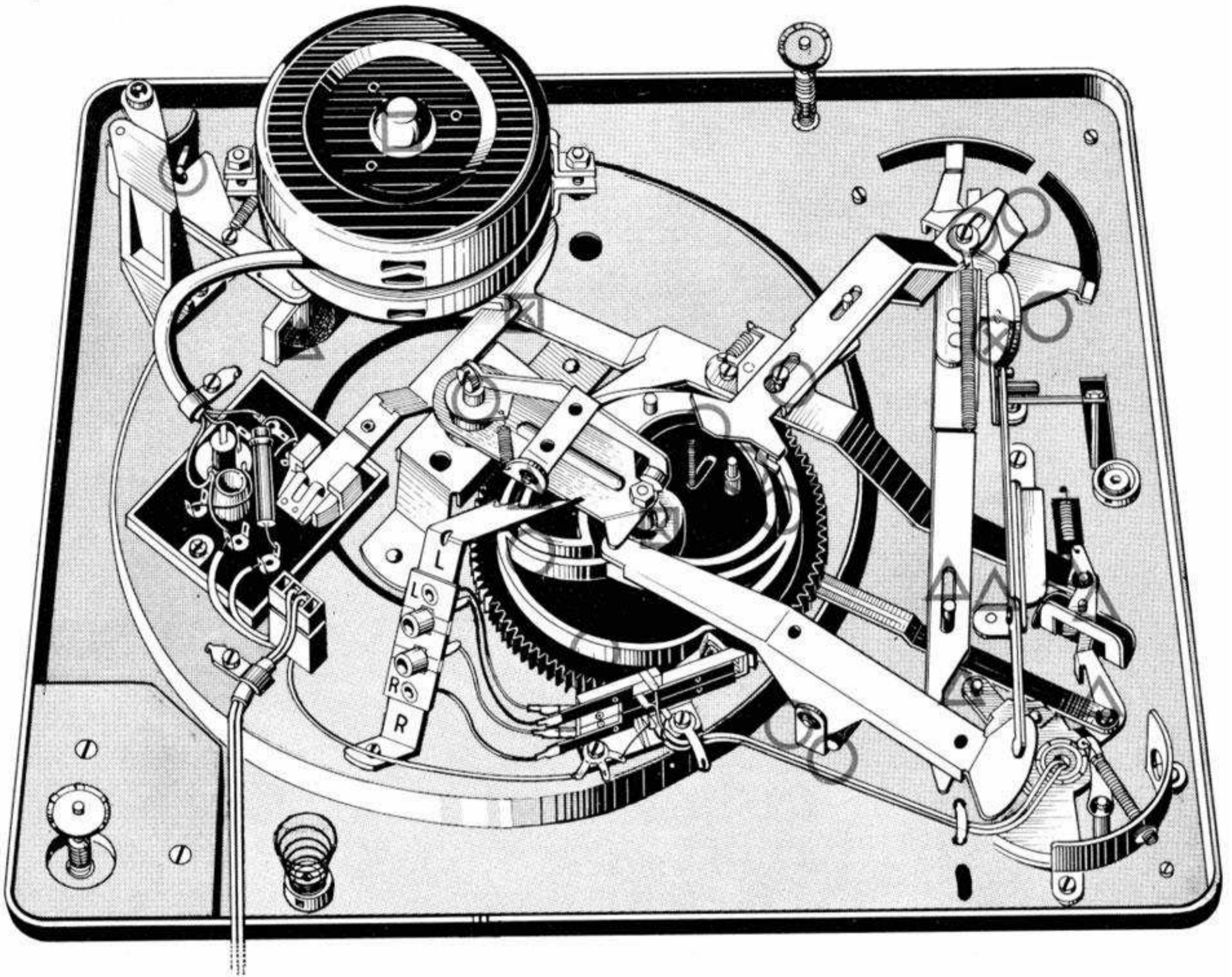

Replacement parts

Ref. No.	Part No.	Description	Number per unit
1	13 E - Ausf. A	45 automatic spindle (accessory)	1
2	12 C - U 208	Automatic spindle AW 2	1
3	12 K - 196	Turntable washer	1
4	12 E - 214	Retaining ring	1
5	12 K - U 329	Turntable mat	1
	12 K - 189	Ring facing	1
6	12 K - U 315	Turntable with mat	1
7	12 K - U 4	Speed regulator knob	1
8	12 K - 20	Speed change knob	1
9	12 K - U 301	Switch plate assembly	1
10	Z 3/5a	Machine screw	6
11	4650/4	"C" ring	3
12	5,1/10/1 St	Washer	1
13	4680/5,2/10a	Bowed lockwasher	2
14	12 F - U 4	Speed change lever	1
15	12 K - U 2	Base plate	1
16	12 F - U 186	Shipping screw assembly	1
17		Tonearm assembly with bearings (available only less ref. nos. 37 and 63)	
18	12 K - U 327	Centering disc for 45 records	1

Ref. No.	Part No.	Description	Number per unit
19	12 K - 194	Single play spindle	1
20	Z 3/5a	Machine screw	6
21	M 4/2	Hex nut	6
22	6 K 4/4	Hex nut	2
23	4000/400	Steel ball	1
24	M 4/2	Hex nut	6
25	M 3/7a	Hex nut	2
26	12 F - U 136	Suspension spring (3 pcs to a set)	1
27	12 F - 303	Rubber sleeve	3
28	12 F - 300	Cup	3
29	12 F - 314	Compression spring	3
30	12 F - 298	Threaded disc	3
31	4,2/7/0,3 St	Washer	2
32	12 F - 291	Compression spring	2
33	12 F - 249	"C" ring	2
34	12 F - 254	Spring cup	2
34a*	M 4/2	Hexnut	4
35	12 F - 255	Washer	2
36	4650/4	"C" washer	3
37	12 K - U 305	Tonearm assembly	1
38	12 K - 78	Bearing screw, short	1
39	12 K - 36	Switch lever assembly	1
40	4680/4,2/8d	Tonearm handle	1
41	4,2/8/0,5 St	Washer	1
42	4693/4	Grip ring	1
43	12 K - U 270	Retainer	1
44	12 K - 314	Shield	1
45	12 K - 68	Bearing housing	1
46	12 F - U 60	Ball bearing race	2
47	12 K - 71	Stop nut	1
48	12 K - 90	Positioning screw	1
49	4680/5,2/10a	Bowed lockwasher	2
50	Z 3/5a	Machine screw	6
51	12 K - U 319	Balance weight	1
52	12 K - U 317	Balance weight with spindle	1
53	12 K - 199	Spindle	1
54	15 N - 54	Clamping screw	1
55	12 K - U 311	Spring barrel	1
56	12 K - 44	Tone arm cable (right channel)	1
57	12 K - 46	Tone arm cable (left channel)	1
58	12 K - 62	Positioning screw	1
59	15 N - 74	Damping ring	1
60	4650/3,2	"C" ring	2
61	12 K - 76	Bearing screw, long	1
62	15 N - 9	Marker	1
63	12 K - U 310	Bearing frame assembly	1
	12 K - U 308	Bearing frame assembly with bearing housing	1
64	12 K - U 40	Guide ring	1
65	12 K - 64	Adjusting ring	1
66	12 K - U 46	Spring lever	1
67	12 K - 66	Ring	1
68	4650/2,3	"C" ring	11
69	12 F - U 60	Bearing race	2
70	12 K - 104	Mounting screw	1
71	12 K - U 54	Arm latch assembly	1
72	12 K - 102	Tensioning block	1
73	12 K - U 52	Bearing holder	1
74	M 2,6/4b	Hexnut	1
75	12 K - 106	Tonearm rest	1
76	M 3/7a	Hexnut	2
77	12 K - U 50	Arm latch assembly	1
78	12 K - U 78	Arm lift lever	1
79	M 2/4	Hexnut	1
80	12 K - 95	Damping block	1
81	12 K - U 321	Dress-up plate (metric markings)	1
	12 K - U 323	Dress-up plate (inch markings)	1
82	12 K - 108	Switch button	2
83	Z 3/5a	Machine screw	6
84	12 F - 252	Special screw (threaded)	2
	12 F - 251	Special screw (pierced)	2

Fig. 21 Exploded view, parts above chassis

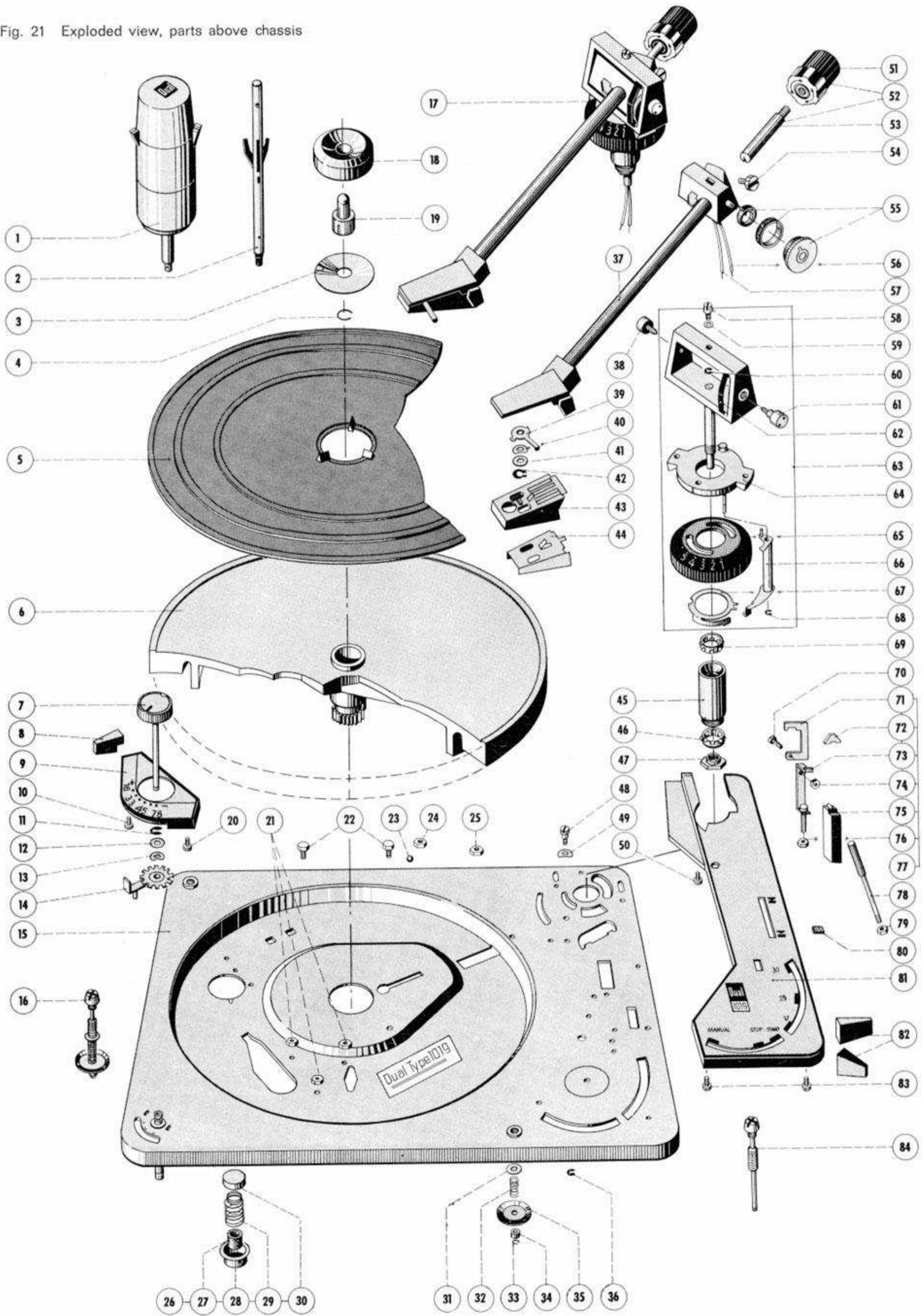
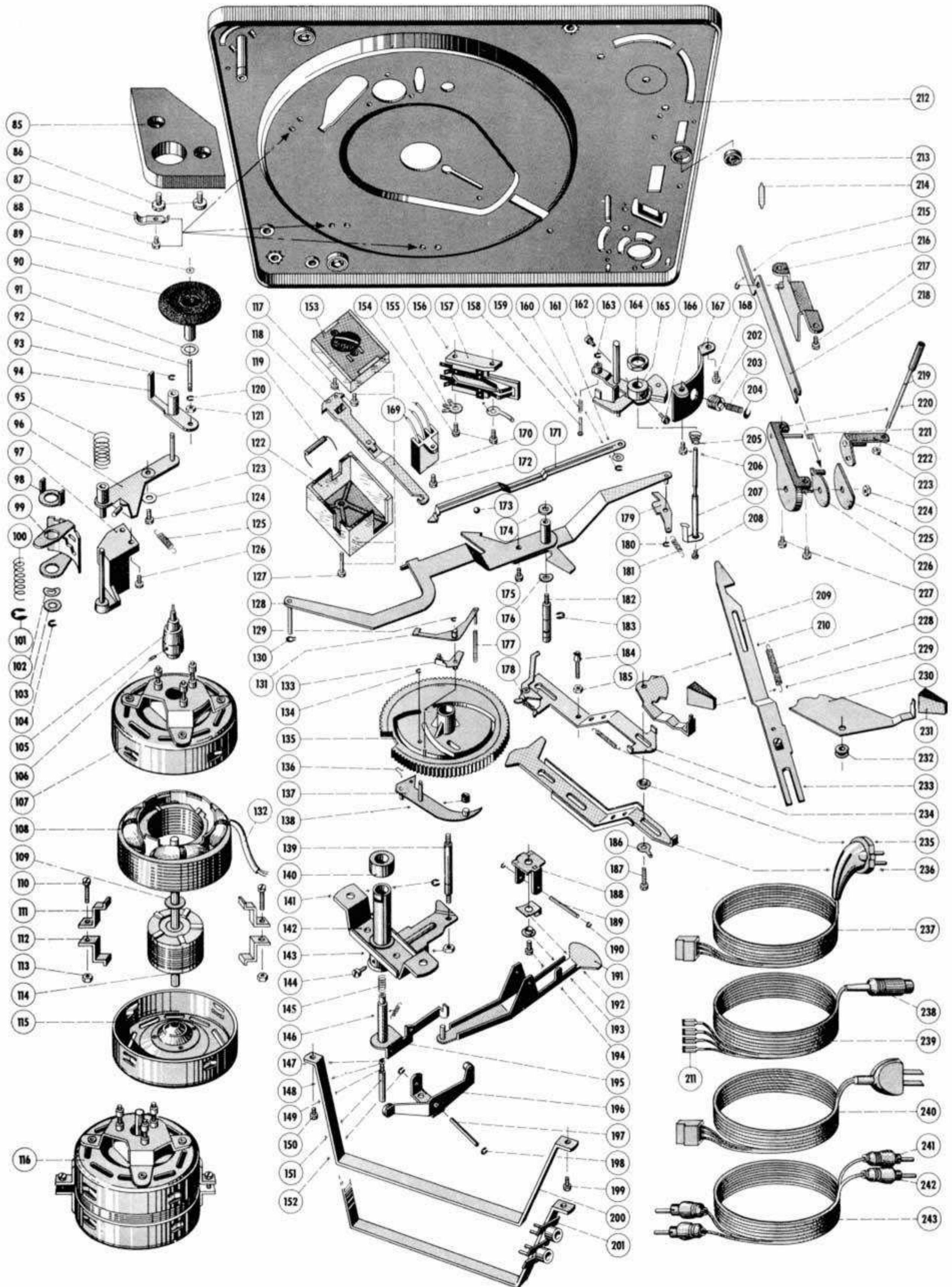

Fig. 22 Exploded view, parts below chassis



Ref. No.	Part No.	Description	Number per unit
85	12 F - 7	Plate	1
86	Z 4/5a	Machine screw	2
87	12 A - 325	Cable clamp	3
88	Z 3/4d	Machine screw	4
89	12 F - 45	Lockwasher	1
90	12 F - U 13	Idler wheel	1
91	11 C - 138	Washer	1
92	12 F - 41	Idler wheel shaft	1
93	4650/3,2	"C" ring	2
94	12 F - U 9	Lever and stud assembly	1
95	12 F - 24	Compression spring	1
96	12 F - U 7	Rocker assembly	1
97	12 F - U 8	Support assembly	1
98	12 F - 14	Speed regulator detent	1
99	12 F - 16	Switch segment	1
100	12 F - 18	Compression spring	1
101	4650/6	"C" ring	2
102	4680/3,2/8c	Bowed lockwasher	1
103	3,2/10/1 St	Washer	1
104	4650/2,3	"C" ring	11
105	31 N - U 20	Motor pulley, 50-cycle	1
	31 N - U 28	Motor pulley, 60-cycle	1
106	G 2,6/3,5	Set screw	1
107	31 N - U 6	Upper end-bell assembly	1
108	31 N - U 1	Stator assembly	1
109	5,3/10/2 F	Washer	1
110	Z 4/12a	Machine screw	2
111	31 N - 40	Retaining bracket	4
112	31 N - 40	Retaining bracket	4
113	M 4/7	Hexnut	2
114	31 N - U 15	Rotor assembly	1
115	31 N - U 5	Lower end-bell assembly	1
116	31 N - U 10	Motor assembly, less motor pulley	1
117	Z 3/8a	Machine screw	2
118	12 F - U 57	Switch slide	1
119	4020/83	Capacitor	1
120	4650/2,3	"C" ring	11
121	M 3/4	Hexnut	2
122	12 F - 152	Power switch cover	1
123	3,2/6/0,5 St	Washer	1
124	Z 3/3c	Machine screw	6
125	12 F - 112	Idler wheel spring	1
126	Z 3/5a	Machine screw	6
127	Z 3/30a	Machine screw	1
128	12 F - U 43	Switch arm	1
129	4650/1,5	"C" washer	3
130	4693/3	Grip ring	1
131	12 F - U 42	Shut-off lever	1
132	J 07 nf/150	Insulating sleeve	1
133	12 F - U 40	Friction plate assembly	1
134	4650/2,3	"C" washer	11
135	12 K - U 303	Main cam	1
136	12 D - 57	Snap ring	1
137	12 H - U 11	Cam follower lever	1
138	12 F - 84	Rubber bumper	1
139	12 D - 36	Main cam bearing post	1
140	12 F - U 28	Ball bearing assembly	1
141	4650/6	"C" washer	2
142	12 F - U 22	Turntable bearing support assembly	1
143	M 4/2	Hexnut	6
144	12 F - 63	Machine screw	1
145	12 F - 64	Compression spring	1
146	12 D - 96	Change lever tension spring	1
147	4650/1,5	"C" washer	3
148	2,1/5/0,5 St	Washer	1
149	12 F - 68	Compression spring	1
150	Z 3/4d	Machine screw	4
151	12 F - U 26	Change actuator stud	1
152	4650/2,3	"C" washer	11
153	12 G - U 28	Switch plate with voltage selector	1
	12 F - U 54	Switch plate less voltage selector	1
154	Z 3/4,5a	Machine screw	2
155	4103/29	Solder lug	1
156	4103/27	Solder lug	1
157	12 F - U 75	Muting switch	1
158	12 F - 168	Spring stud	1
159	12 K - 120	Compression spring	1
160	4650/2,3	"C" ring	1
161	12 K - 144	Washer	1
162	Z 3/6c	Machine screw	1
163	4650/1,5	"C" washer	3

			per unit
164	12 F - 156	Hexnut	1
165	12 K - U 313	Arm segment assembly	1
166	Z 3/6	Machine screw	2
167	12 K - 130	Spring post	1
168	Z 3/3c	Machine screw	6
169	12 G - U 77	Power switch with voltage selector	1
	12 F - U 52	Power switch with slide and cover	1
170	12 F - U 163	4-pin connector w/breakaway power cord	1
171	12 F - 174	Shut-off slide	1
172	Z 3/6	Machine screw	2
173	4000/400	Steel ball	1
174	3,2/7/0,5 St	Washer	1
175	Z 3/3c	Machine screw	6
176	4680/5,2/8	Bowed lockwasher	1
177	12 F - 98	Coiled spring	1
178	12 F - 137	Tension spring	1
179	12 K - U 18	Latch	1
180	4650/2,3	"C" washer	11
181	11 A - 10	Tension spring	2
182	12 F - 100	Grooved shaft	1
183	4650/4	"C" washer	3
184	12 F - U 51	Set screw	1
185	M 3/4	Hexnut	2
186	4103/32	Solder lug	1
187	Z 3/12a	Machine screw	1
188	12 K - 140	Main lever bearing support	1
189	12 D - 212	Main lever shaft	1
190	4650/2,3	"C" washer	11
191	12 K - U 325	Main lever	1
192	12 K - 142	Leaf spring	1
193	12 B - 50	Spacer	1
194	Z 3/6b	Machine screw	1
195	12 F - U 24	Change lever	1
196	12 D - U 60	Cam rocker	1
197	12 D - 102	Cam rocker shaft	1
198	4650/2,3	"C" washer	11
199	Z 3/7a	Machine screw	1
200	12 K - 180	Stand	1
201	12 K - U 100	Stand with phono jacks	1
202	12 K - 132	Threaded bushing	1
203	12 K - 134	Tension spring	1
204	12 K - 136	Positioning washer	1
205	12 K - 128	Helical spring	1
206	Z 3/3c	Machine screw	6
207	12 K - U 60	Lift screw	1
208	12 D - 209	Guide pin	1
209	12 K - U 64	Arm positioning slide	1
210	12 F - 123	Manual/automatic selector	1
211	4012/40	Blade connector	4
212	12 K - U 2	Base plate assembly	1
213	12 F - 298	Threaded bushing	3
214	12 F - 172	Audio cable, spring retainer	1
215	4650/2,3	"C" washer	11
216	12 K - U 80	Bearing support, connecting lever	1
217	Z 3/7a	Machine screw	1
218	12 K - 176	Connecting lever	1
219	12 K - U 78	Arm lift rod	1
220	12 K - U 70	Support bracket with drive washer	1
221	12 K - 162	Torsion spring	1
222	12 K - U 76	Drive cam assembly	1
223	M 2/4	Hexnut	1
224	M 4/2	Hexnut	6
225	12 K - 160	Cover washer	1
226	12 K - U 74	Drive washer	1
227	Z 3/3c	Machine screw	6
228	12 A - 452	Tension spring	1
229	12 K - 108	Selector knob	2
230	12 F - 118	Record size selector lever	1
231	12 K - 108	Selector knob	2
232	12 F - 120	Spacer, short	1
233	12 F - U 41	Switch lever assembly	1
234	11 A - 10	Tension spring	2
235	12 F - 132	Spacer, long	1
236	12 F - 135	Start lever	1
237	12 F - U 184	Power cord, European	1
238	4012/21	Miniature 5-pin plug	1
239	12 F - U 133	Plug-in output cable	1
240	12 F - U 175	Power cord, American	1
241	4012/22	Phono plug (yellow) for output cable	2
242	4012/23	Phono plug (red) for output cable	2
243	12 F - U 127	Output cable, phono connector	1