



NOTICE DE SERVICE

228, Bd de la Villette
75019 PARIS
Tél. : 203.44.65

RÉCEPTEUR TO 205 SPÉCIAL AUTO



SCHÉMA DE PRINC



CONTACTS CLAVIERS (Commute M/A - PO/C)

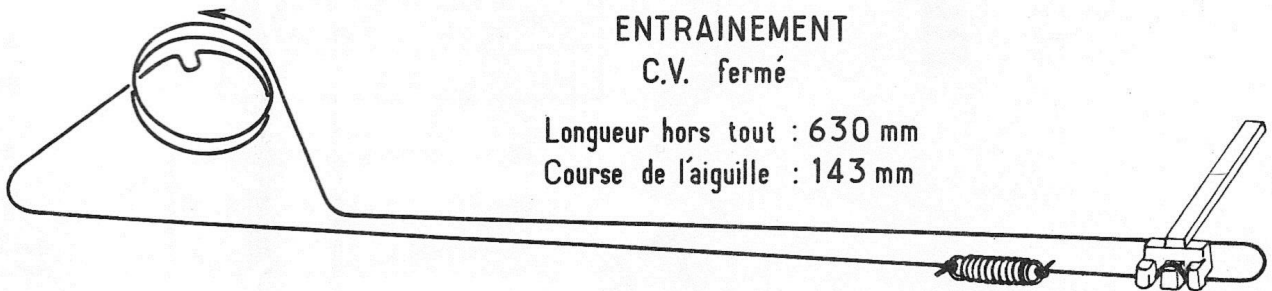
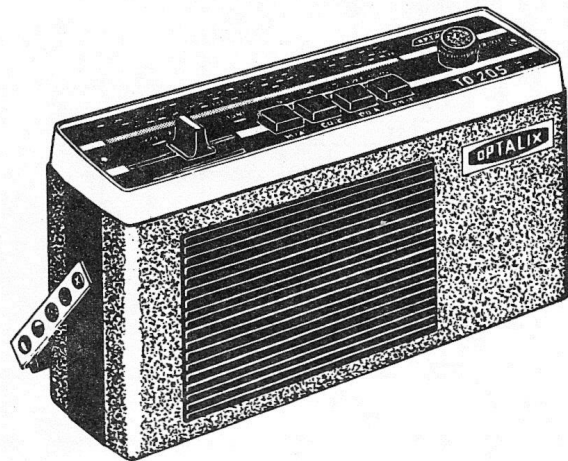
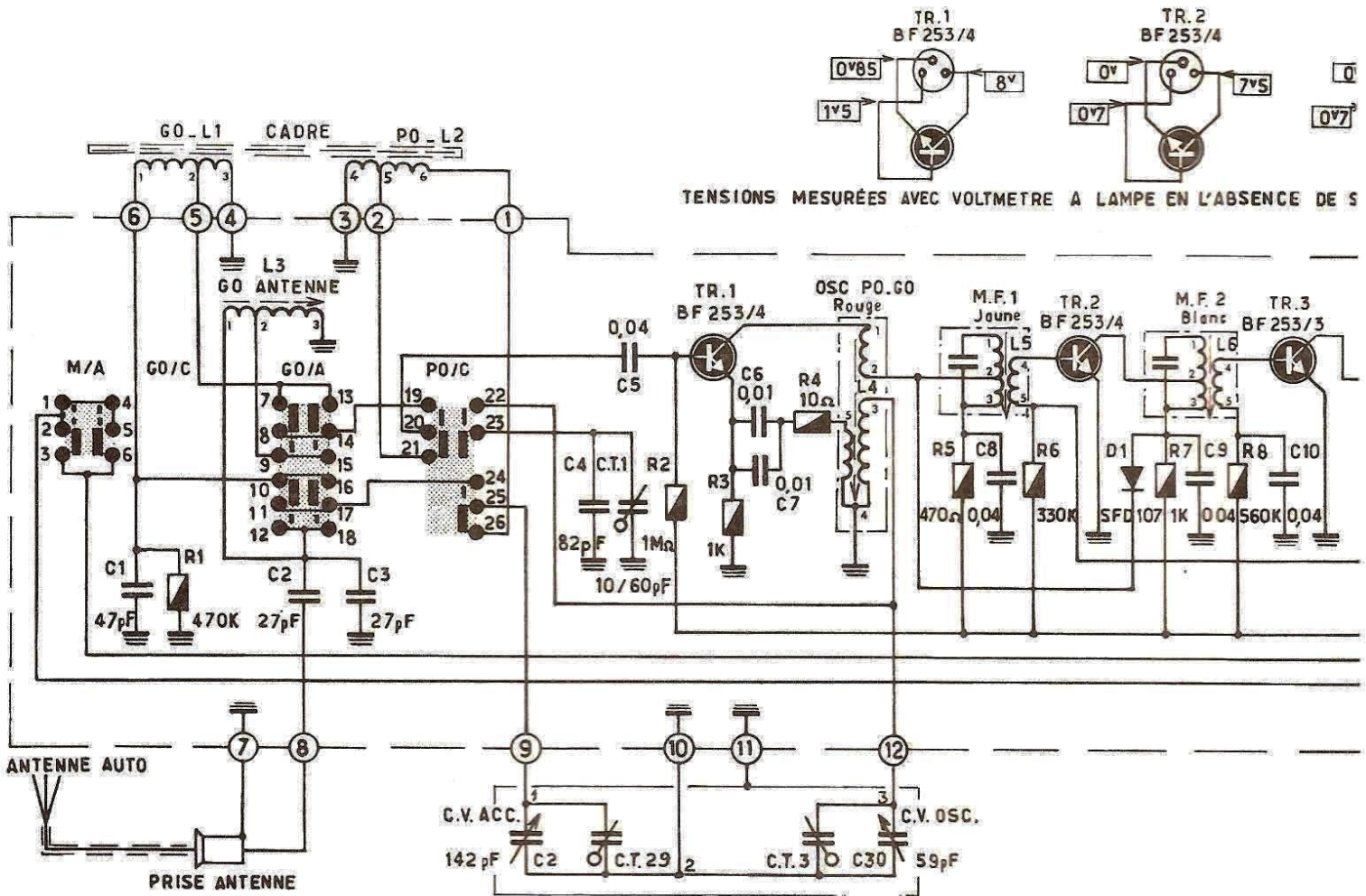
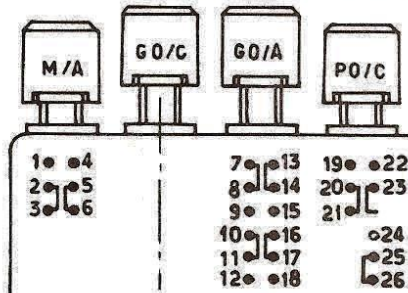

COMMUTATIONS CLAVIER	
en PO/C	7-8 10-11 13-14 16-17 20-21 25-26
en GO/C	7-8 10-11 13-14 16-17 19-20 22-23 24-25
en GO/A	8-9 11-12 14-15 17-18 19-20 22-23 24-25
M/A	2-3 5-6

COMMUTATIONS ALIMENTATION	
PILES	4-5 6-7 9-10
BATTERIE	1-2 3-4 8-9

CONTACTS PRISE D'ALIMENTATION



OSC PO.G0 360M. Rouge

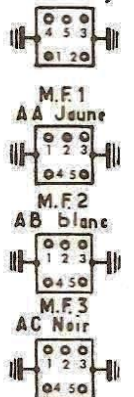

Les Condensateurs sont dans les boîtiers

RINCIPE

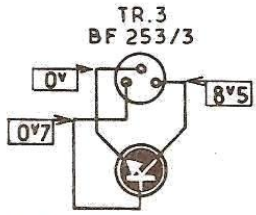

FRÉQUENCE MF : 452 KHZ
 GAMMES D'ONDES : PO 520 _ 1620KCS
 GO 150 _ 270KCS

ENCE DE SIGNAL PAR RAPPORT AU - (Négatif) GÉNÉRAL.

DÉBIT SANS PORTEUSE : 12 MA / 9V
 33 MA / 12V
 36 MA / 14V

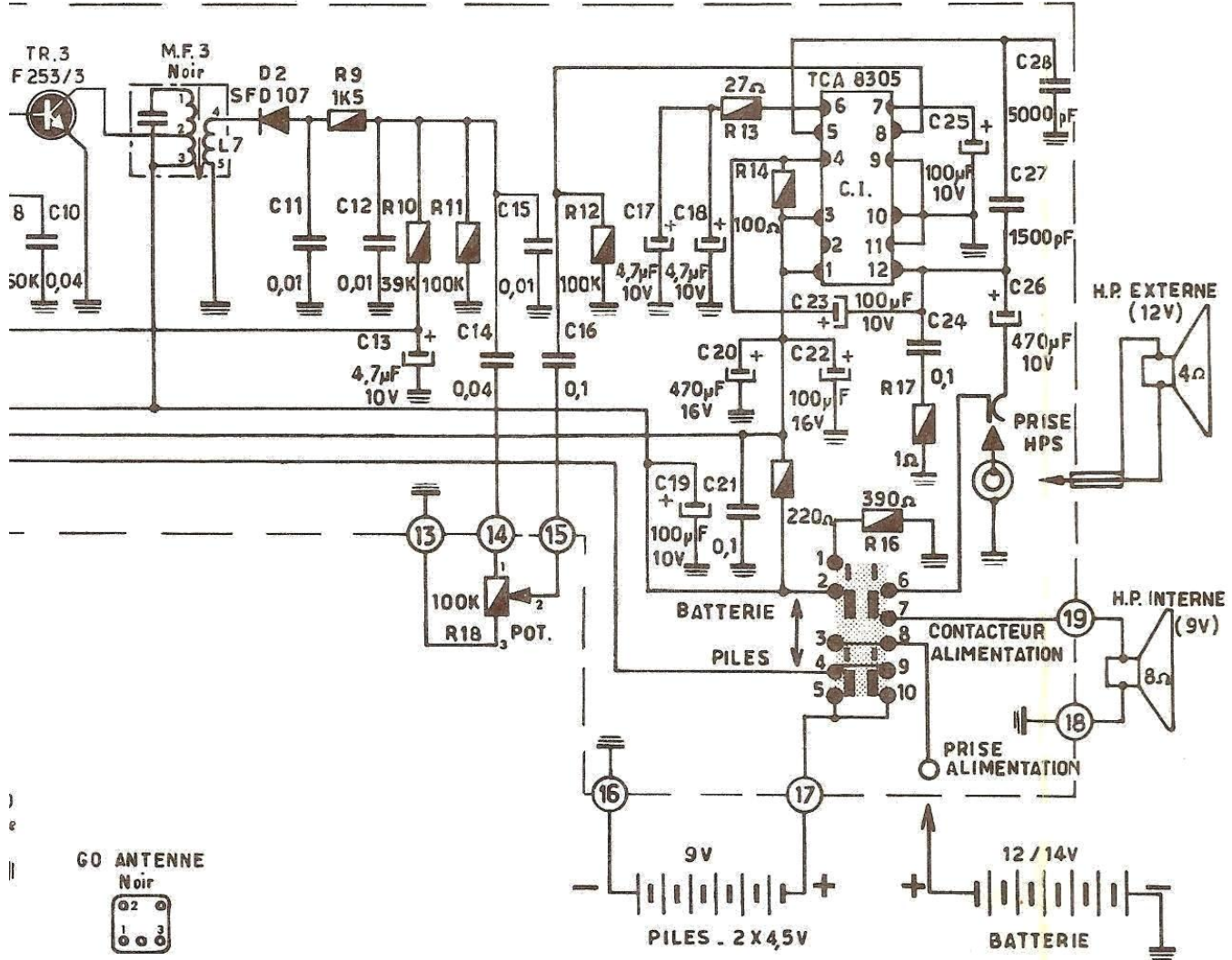

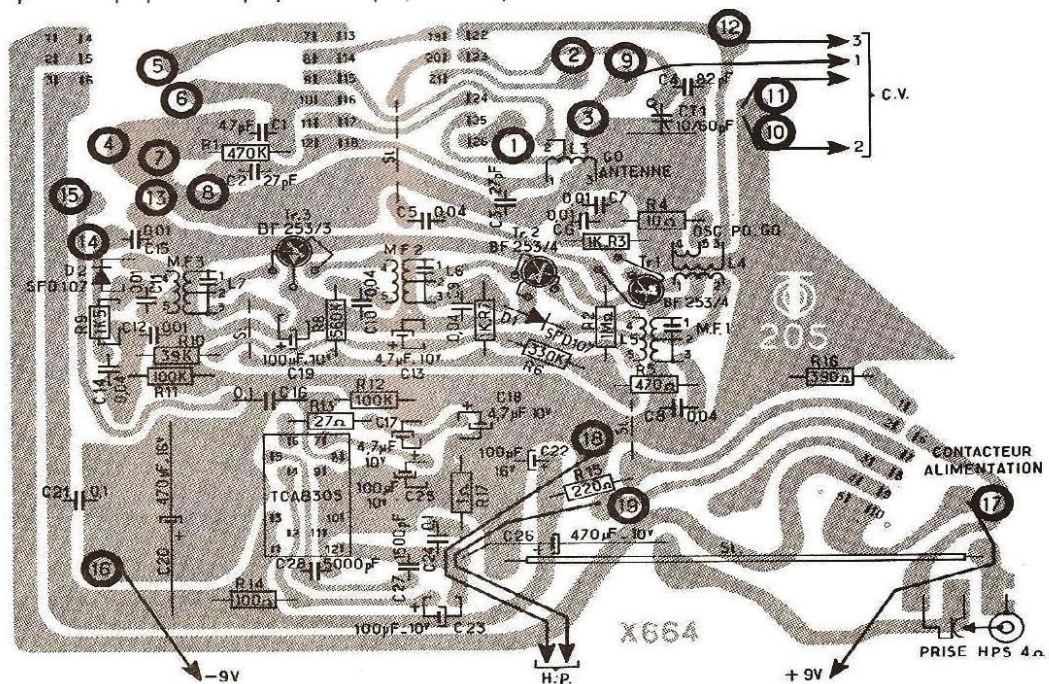
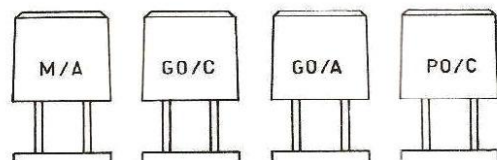
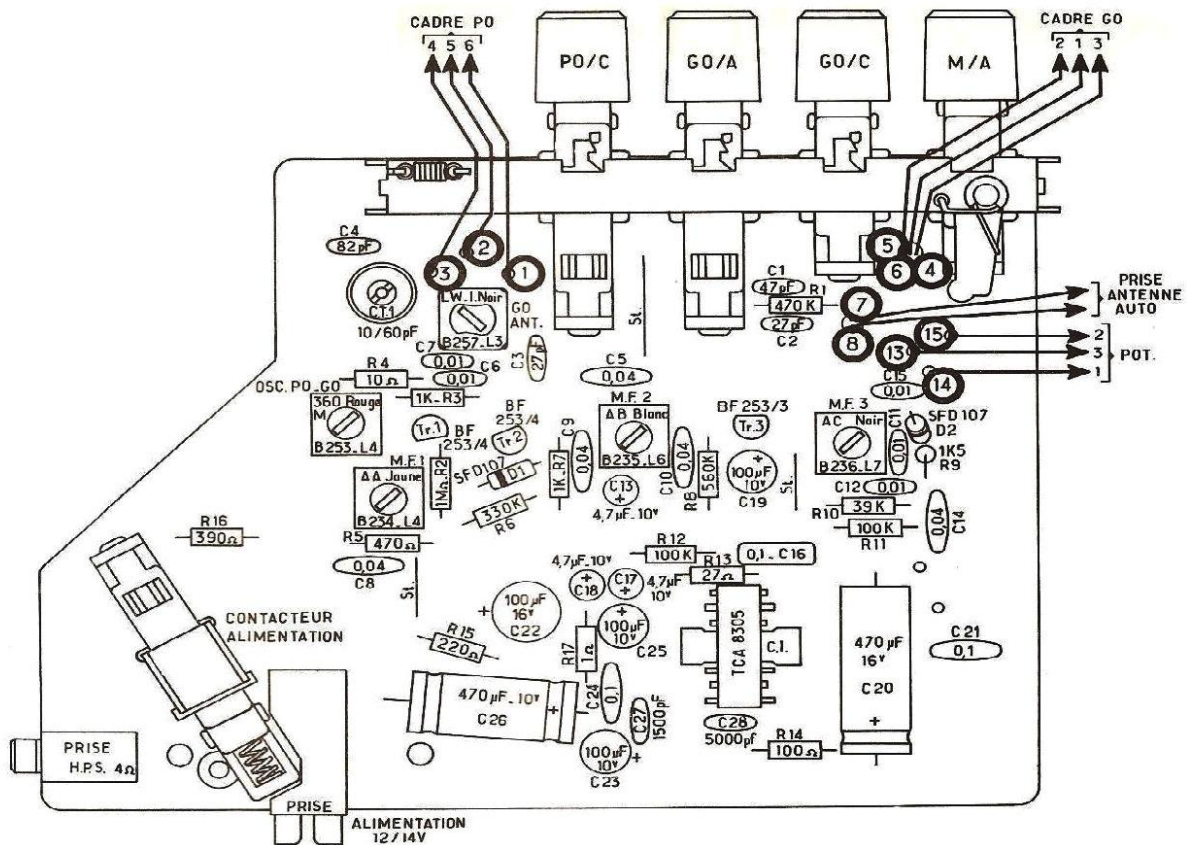

AN

CABLAGE GÉNÉRAL ET TENSIONS TRANSI

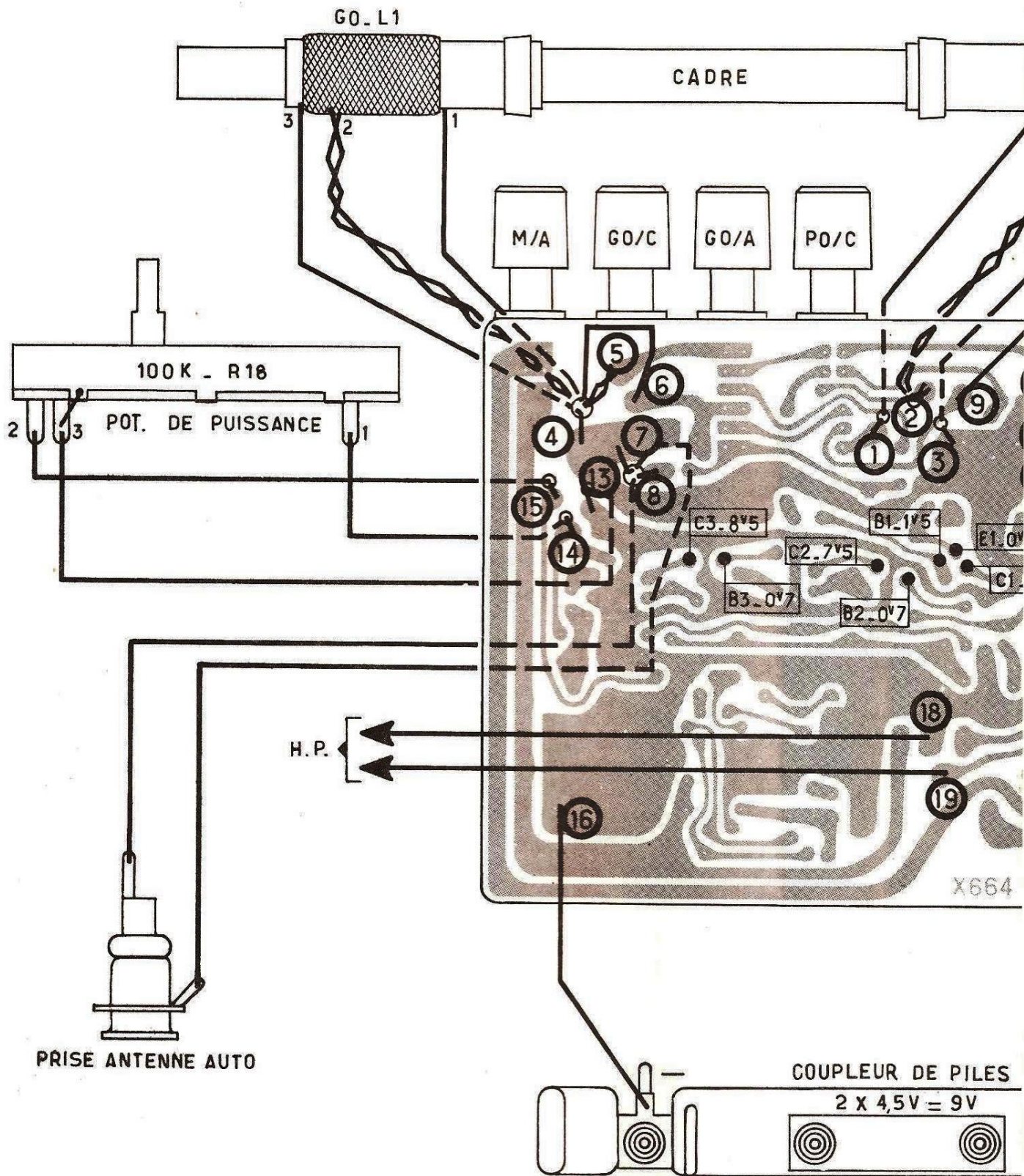

GÉNÉRAL ET TENSIONS TRANSISTORS

